

# Digilent PmodAD1™ Analog To Digital Module Converter Board Reference Manual

Revision: 04/12/05



215 E Main Suite D | Pullman, WA 99163  
(509) 334 6306 Voice and Fax

## Overview

The Analog to Digital Module Converter Board (the AD1™) converts signals at a maximum sampling rate of one million samples per second, fast enough for the most demanding audio applications.

The AD1 uses a 6-pin header connector, and at less than one square inch is small enough to be located at the signal source.

Features include:

- two ADCS7476MSPS 12-bit A/D converter chips
- a 6-pin header connector
- a 6-pin connector
- two 2-pole Sallen-Key anti-alias filters
- two simultaneous A/D conversion channels at up to one MSa per channel
- very low power consumption
- small form factor (0.95" x 0.80").

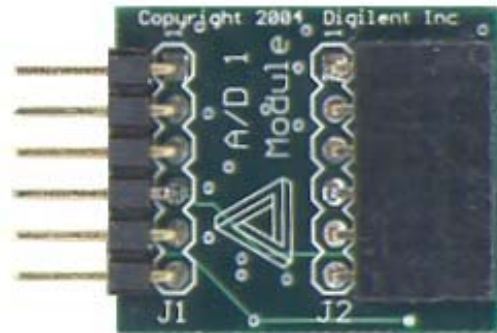

## Functional Description

The AD1 converts an analog input signal ranging from 0-3.3 volts to a 12-bit digital value in the range 0 to 4095.

The AD1 has two simultaneous A/D conversion channels, each with a 12-bit converter and filter. Each channel can sample a separate stream of analog signals. The AD1 can also convert a single stream of analog signals using only one channel.

Each channel has two 2-pole Sallen-Key anti-alias filters with poles set to 500 KHz. The filters limit the analog signal bandwidth to a

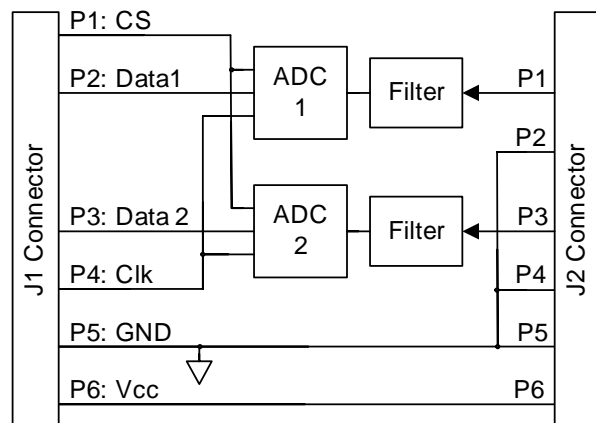

**AD1 Circuit Diagram**

frequency range suitable to the sample rate of the converter.

The AD1 uses the SPI/MICROWIRE™ serial bus standard to send converted data to the host system. The serial bus can run at up to 20 MHz.

The AD1 has a 6-pin header and a 6-pin connector for easy connection to a Digilent system board or other Digilent products. Some system boards, like the Digilent Pegasus board, have a 6-pin header that can connect to

the AD1 with a 6-pin cable. To connect the AD1 to other Digilent system boards, a Digilent Modular Interface Board (MIB) and a 6-pin cable may be needed. The MIB plugs into the system board, and the cable connects the MIB to the AD1.

The AD1 can be powered by voltage from either a Digilent system board or an outside device. Damage can result if power is supplied from both sources or if the outside device supplies more than 3V.

For more information, see [www.digilentinc.com](http://www.digilentinc.com).

For more information about the ADCS7476MSPS 12-bit converter chip, refer to the corresponding National Semiconductor data sheet at [www.national.com](http://www.national.com).