

# Digilent PmodUSB2 Module Board Reference Manual

Revision: 3/11/05



www.digilentinc.com

215 E Main Suite D | Pullman, WA 99163  
(509) 334 6306 Voice and Fax

## Overview

The Digilent PmodUSB2 Module Board (the USB2) is used to create a USB 2.0 connection on any Digilent system board.

The USB2 is based on the Cypress CY7C68013 USB controller and can be used to configure system boards or exchange data with a PC.

Digilent firmware in the Cypress USB controller works with Digilent's PC-based Adept software to coordinate JTAG programming and user data transfers. The data port uses a protocol similar to the 14-signal "Enhanced Parallel Port" (EPP) protocol.

The USB2 is compatible with all newer Digilent system boards including the Spartan-3, Pegasus, D2SB™, and D2FT™ boards. It can also be used with the older D2 and D2E boards for user data transfers, but not for programming. For more information, see the reference manuals at [www.digilentinc.com](http://www.digilentinc.com).

Features include:

- USB 2.0 connector
- status indicator LED
- Cypress CY7C68013 USB controller
- small form factor (3.00" x 2.20").

## Functional Description

The USB2's Cypress USB controller is a convenient USB 2.0 connection solution that includes the USB interface and an 8051-based processor.

Digilent firmware in the Cypress USB controller uses a packet-transfer protocol for JTAG programming and user data transfers. Digilent's Adept Suite software includes two application programs, Export (for JTAG

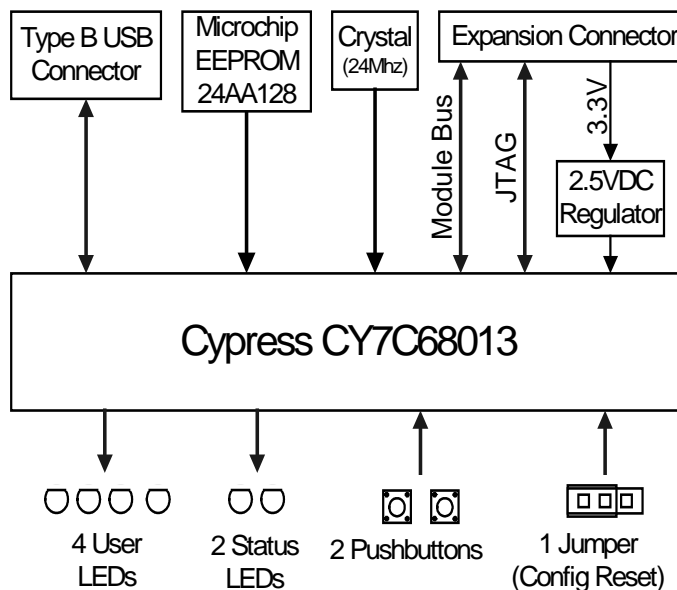
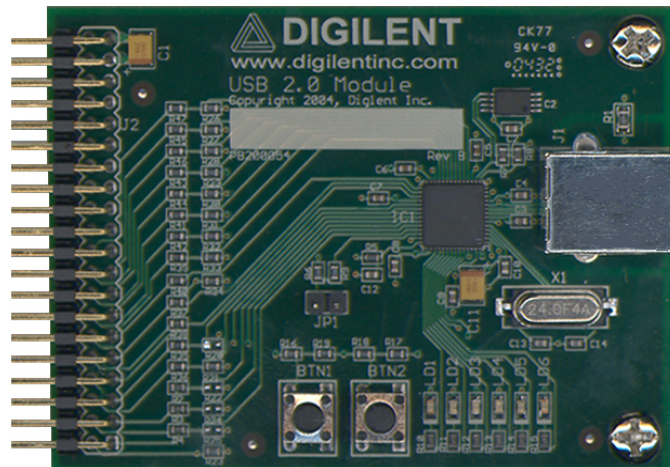

**USB2 Circuit Diagram**

programming) and Transport (for user data transfers).

For JTAG programming, the Adept software can transfer .bit or .svf files directly to the Cypress USB controller where firmware then drives the JTAG scan chain. For more information see the *Digilent Adept Reference Manual* at [www.digilentinc.com](http://www.digilentinc.com).

For data transfer between a system board and an attached PC, Digilent's Adept Software Developers Kit contains the necessary DLLs, APIs, and Windows drivers to allow users to create their own USB2 transport applications. Digilent also provides a VHDL reference design. The VHDL source file "dpimref.vhd" is available as a separate download. See the *Digilent Software Development Kit*, the *Digilent Port Communications Reference Manual*, and the *Digilent Parallel Interface Model Reference Manual*. They can all be downloaded from [www.digilentinc.com](http://www.digilentinc.com).

The firmware in the Cypress USB controller can be modified using the Cypress EZ-USB Development kit available from Cypress. For more information, see [www.cypress.com](http://www.cypress.com). Digilent does not offer user support for modifying the firmware.

## USB2 Communications

The Adept software manages communications with the USB2. It can identify a particular USB2 module using either a serial number or an ID string. A unique serial number and the default ID string "DModUsb" are programmed into the USB2 and the serial number is printed on a label affixed to the module. Digilent provides a "USB Administrator" tool as part of the Adept software that can be used to modify the 16-character ID string. See the *Digilent Adept Reference Manual* for more information.

The USB2 can be used for JTAG programming or user data transfers only after it has been identified within the Adept software. The USB2 is identified by adding its serial number or ID string to a Device Table accessed through the

Communications Module dialog box in the Adept Suite. See the *Digilent Adept Reference Manual* for more information.

The USB2 should be connected to a system board's A1, B1, or C1 expansion connectors for proper operation. It can be connected to other expansion connectors, but JTAG programming will not be available. It is recommended that the system board be turned off prior to connecting the module.

## User I/O Devices

The USB2 contains several I/O devices, including six status LEDs, two debounce pushbuttons, and one 2-pin jumper.

### Pushbuttons and Jumper

The pushbuttons and jumper are not used by the Digilent firmware on the Cypress USB controller, but they can be configured as inputs with the Cypress EZ-USB Development Kit.

### Status LEDs

LED1: Indicates that the Digilent firmware is loaded and ready.

LED2: Indicates data activity on the USB2 Module.

LED3-6: Not currently used. They can be configured as user outputs with the Cypress EZ-USB Development Kit.

## Useful Downloads

The following items are all available for free from [www.digilentinc.com](http://www.digilentinc.com).

### Documents

- Digilent Adept Reference Manual
- Digilent Port Communications Reference Manual
- Digilent Parallel Interface Model Reference Manual
- Digilent JTAG Scan Reference Manual

### Software

- Digilent Adept Suite
- Digilent Adept Software Developers Kit

### Reference Designs

- VHDL source file “dpimref.vhd”

## Pinout Table

The table below provides the pin assignments for the expansion connector.

Pin #	Signal
1	TDI
2	TDO
3	TMS
4	TCK
5	INT
6	JTSEL
7	WAIT
8	RESET
9	/DSTB
10	WRITE
11	DB7
12	ASTB
13	DB5
14	DB6
15	DB3
16	DB4
17	DB1
18	DB2
19	
20	DB0
21	
22	
23	
24	
25	
26	
27	
28	
29	
30	
31	
32	
33	
34	
35	
36	
37	VDD33
38	
39	GND
40	