

Pico RGB Keypad Base (PIM551)

Pico Landing

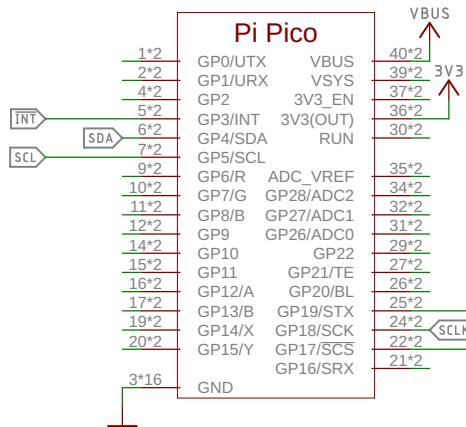

Faux SPI APA102 Buffer

Allows driving APA102s via SPI interface including a chip select line. Also level shifts signals from 3V3 up to VBUS.

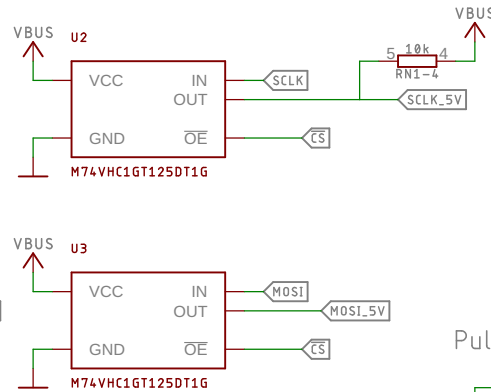

IO Expander For Keypad

Solder jumpers allow reconfiguring the I2C address so that multiple matrices can be chained together (though they will share a common interrupt pin).

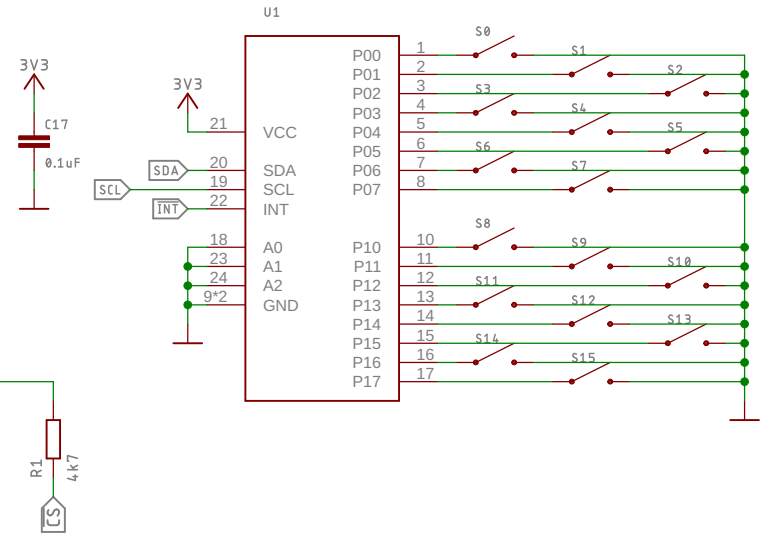

APA102 LEDs and Decoupling

