

Discovery kits with increased-frequency 800 MHz STM32MP157 MPUs

Introduction

The STM32MP157D-DK1 and STM32MP157F-DK2 Discovery kits (STM32MP157x-DKx) are designed as complete demonstration and development platforms for STMicroelectronics Arm®-based dual Cortex®-A7 32 bits and Cortex®-M4 32 bits MPUs in the STM32MP1 Series and their STPMIC1 companion chip. They leverage the capabilities increased-frequency 800 MHz of STM32MP1 Series microprocessors to allow users to develop applications using STM32 MPU OpenSTLinux Distribution software (such as STM32MP1Starter) for the main processor and STM32CubeMP1 software for the co-processor.

They feature 16-bit DDR3L 4 Gbits at 533 MHz, MIPI DSISM 2 lanes at 1 Gbps, USB Type-C® DRP HS port, USB Type-A Host HS ports, audio codec with analog audio input / output, microSD™ card high-speed mode up to 50 MHz, Gigabit Ethernet, HDMI® up to 720p60 (1280 × 720), 40-pin extended GPIOs, ARDUINO®, Wi-Fi® 802.11b/g/n, Bluetooth® Low Energy 4.1, and ST-LINK/V2-1 (UART console).

The STM32MP157F-DK2, shown with display removed in Figure 1 and Figure 2, is used as a reference design for user application development. It cannot be considered as the hardware design of a final application.

The hardware features of the Discovery kits are available for users to develop their applications: USB, Ethernet, LTDC, TFT LCD MIPI DSISM, microSD™ card, audio codec, user buttons, Wi-Fi®, and Bluetooth® Low Energy. Extension headers allow easy connection of an ARDUINO® board for a specific application.

An ST-LINK/V2-1 is integrated on the board, as embedded in-circuit debugger and programmer for the STM32 MPU and the USB Virtual COM port bridge.

Figure 1. STM32MP157F-DK2 top view

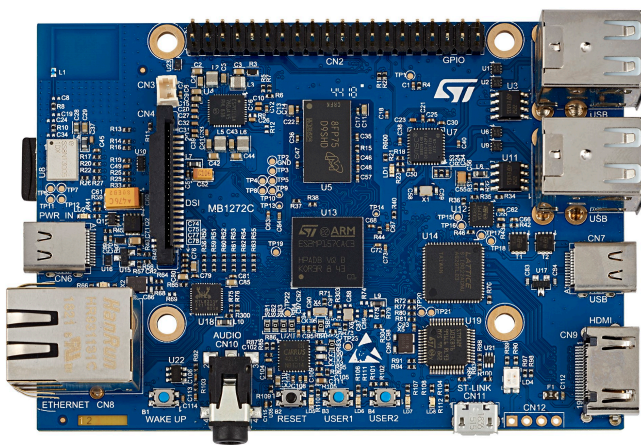
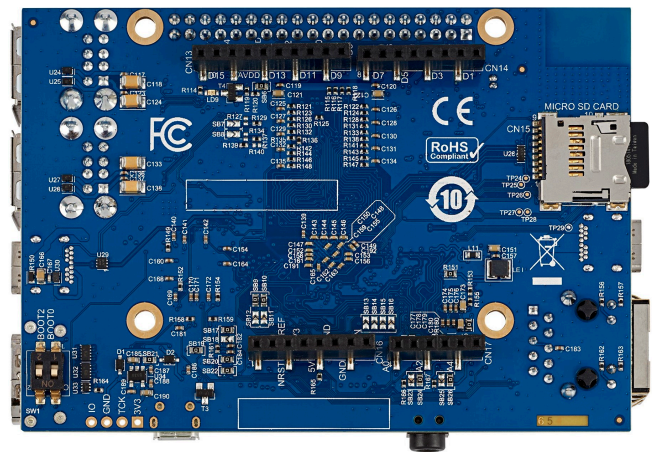

Figure 2. STM32MP157F-DK2 bottom view



Pictures are not contractual.

1 Features

- Common features
 - STM32MP157 Arm[®]-based dual Cortex[®]-A7 800 MHz 32 bits + Cortex[®]-M4 32 bits MPU in TFBGA361 package
 - ST PMIC STPMIC1
 - 4-Gbit DDR3L, 16 bits, 533 MHz
 - 1-Gbps Ethernet (RGMII) compliant with IEEE-802.3ab
 - USB OTG HS
 - Audio codec
 - 4 user LEDs
 - 2 user and reset push-buttons, 1 wake-up button
 - 5 V / 3 A USB Type-C[®] power supply input (not provided)
 - Board connectors:
 - Ethernet RJ45
 - 4 × USB Host Type-A
 - USB Type-C[®] DRP
 - MIPI DSISM
 - HDMI[®]
 - Stereo headset jack including analog microphone input
 - microSD[™] card
 - GPIO expansion connector (Raspberry Pi[®] shield capability)
 - ARDUINO[®] Uno V3 expansion connectors
 - On-board ST-LINK/V2-1 debugger/programmer with USB re-enumeration capability: Virtual COM port and debug port
 - STM32CubeMP1 and full mainline open-source Linux[®] STM32 MPU OpenSTLinux Distribution (such as STM32MP1Starter) software and examples
 - Support of a wide choice of Integrated Development Environments (IDEs) including IAR Embedded Workbench[®], MDK-ARM, and STM32CubeIDE
- Board-specific features
 - 4" TFT 480×800 pixels with LED backlight, MIPI DSISM interface, and capacitive touch panel
 - Wi-Fi[®] 802.11b/g/n
 - Bluetooth[®] Low Energy 4.1

Note: Arm is a registered trademark of Arm Limited (or its subsidiaries) in the US and/or elsewhere.

2 Ordering information

To order an STM32MP157 Discovery kit, refer to [Table 1](#). Additional information is available from the datasheet and reference manual of the target STM32.

Table 1. List of available products

Order code	Board reference	Target STM32	Differentiating feature
STM32MP157D-DK1	<ul style="list-style-type: none"> MB1272 	STM32MP157DAC1	<ul style="list-style-type: none"> Basic security
STM32MP157F-DK2	<ul style="list-style-type: none"> MB1272 MB1407⁽¹⁾ 	STM32MP157FAC1	<ul style="list-style-type: none"> Secure Boot and cryptography LCD Wi-Fi® Bluetooth® Low Energy

1. LCD extension board.

2.1 Codification

The meaning of the codification is explained in [Table 2](#).

Table 2. Codification explanation

STM32MP1XXY-DKZ	Description	Example: STM32MP157F-DK2
STM32MP1	MPU series in STM32 Arm Cortex MPUs	STM32MP1 Series
XX	MPU product line in the series	STM32MP157
Y	Options: <ul style="list-style-type: none"> D: basic security, 800 MHz increased frequency F: Secure Boot, cryptography hardware, 800 MHz increased frequency 	Secure Boot, cryptography hardware, 800 MHz increased frequency
DKZ	Discovery kit configuration: <ul style="list-style-type: none"> DK1: basic DK2: LCD, Wi-Fi®, and Bluetooth® Low Energy 	LCD, Wi-Fi®, and Bluetooth® Low Energy

3 Development environment

3.1 System requirements

- Windows® OS (7, 8 and 10), Linux® 64-bit, or macOS®
- USB Type-C® to USB Type-C® charger 5 V / 3 A
- USB Type-C® to Type-A cable
- USB Type-A or USB Type-C® to Micro-B cable

Note: macOS® is a trademark of Apple Inc. registered in the U.S. and other countries. All other trademarks are the property of their respective owners.

3.2 Development toolchains

- IAR Systems - IAR Embedded Workbench®⁽¹⁾
- Keil® - MDK-ARM⁽¹⁾
- STMicroelectronics - STM32CubeIDE
- GCC

1. On Windows® only.

3.3 Demonstration software

The STM32 MPU OpenSTLinux Distribution and STM32CubeMP1 base demonstration software is preloaded in the microSD™ for easy demonstration of the device peripherals in standalone mode. The latest versions of the demonstration source code and associated documentation can be downloaded from www.st.com.

4 Technology partners

MICRON

- 4-Gbit DDR3L, 16 bits, part number MT41K256M16TW-107-P-V00H

MURATA

- Wi-Fi® 802.11b/g/n + Bluetooth® Low Energy 4.1, part number LBEE5KL1DX-883

5 Conventions

Table 3 provides the conventions used for the ON and OFF settings in the present document.

Table 3. ON/OFF convention

Convention	Definition
Jumper JPx ON	Jumper fitted
Jumper JPx OFF	Jumper not fitted
Jumper JPx [1-2]	Jumper fitted between Pin 1 and Pin 2
Solder bridge SBx ON	SBx connections closed by 0 Ω resistor
Solder bridge SBx OFF	SBx connections left open
Resistor Rx ON	Resistor soldered
Resistor Rx OFF	Resistor not soldered

6 Delivery recommendations

Before first use, check the board for any damage that might have occurred during shipment, that all socketed components are firmly fixed in their sockets and that none are loose in the plastic bag.

7 Hardware layout and configuration

Figure 3. STM32MP157x-DKx hardware block diagram

Figure 4. STM32MP157x-DKx PCB layout: top side

Figure 5. STM32MP157x-DKx PCB layout: bottom side

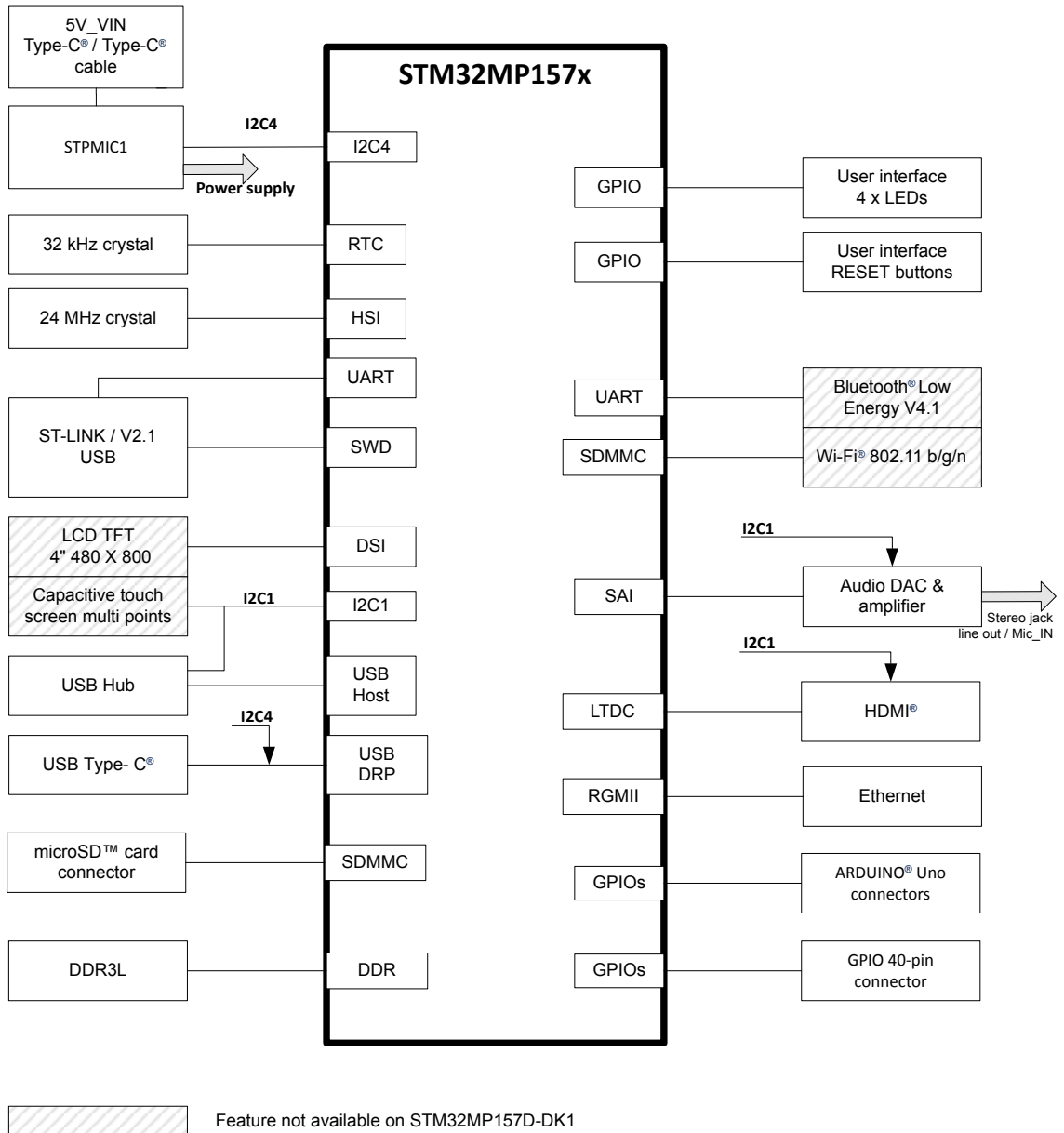

7.1 Embedded ST-LINK/V2-1

7.1.1 Description

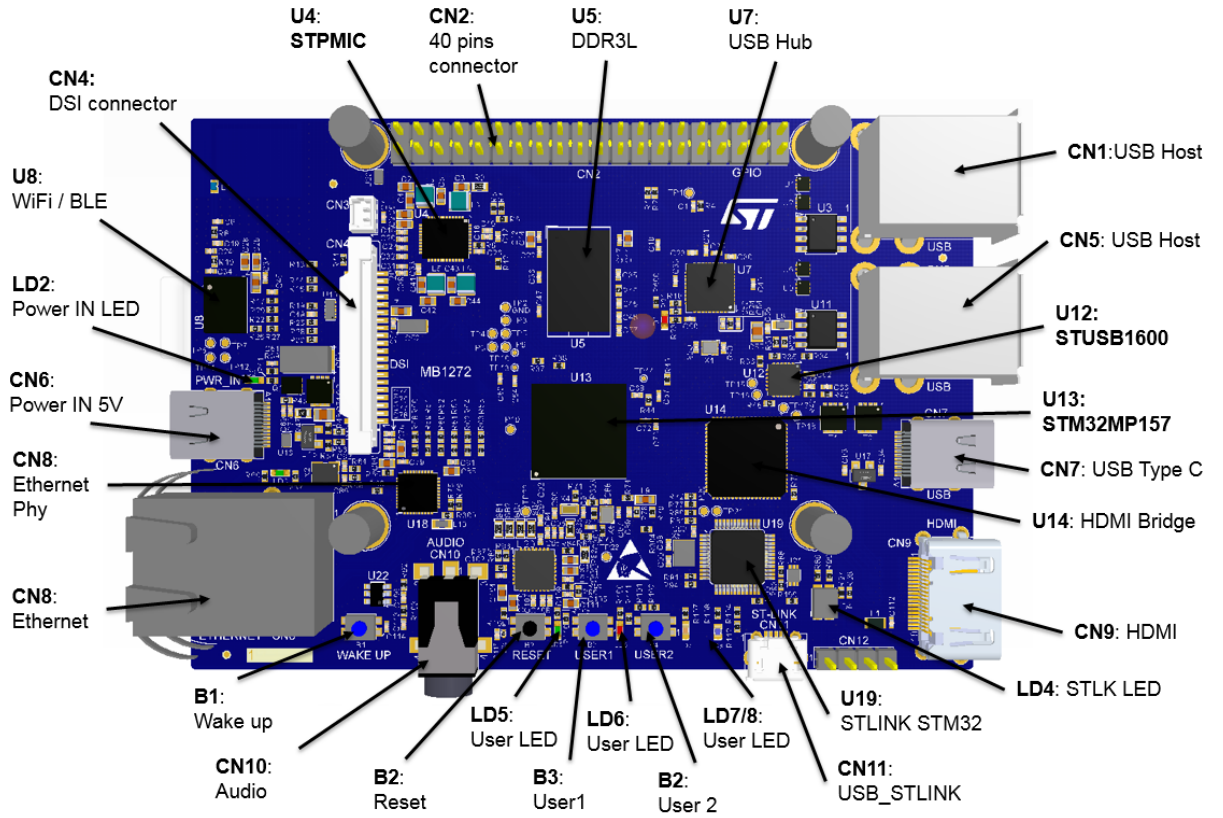
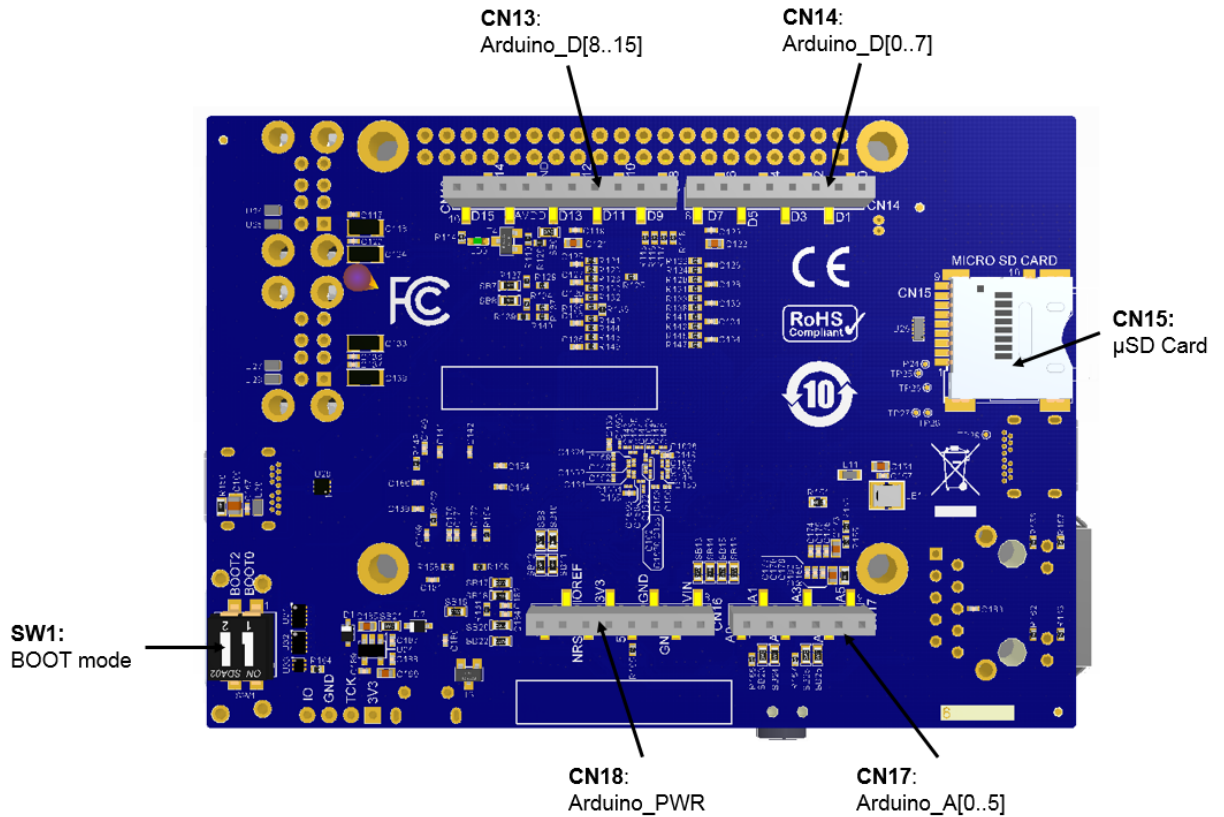
To debug the on-board STM32 MPU, the ST-LINK/V2-1 programming and debugging tool is integrated in the STM32MP157x-DKx Discovery kit. The embedded ST-LINK/V2-1 supports only SWD and VCP for STM32 devices. For information about the debugging and programming features of ST-LINK/V2-1, refer to the *ST-LINK/V2 in-circuit debugger/programmer for STM8 and STM32 user manual (UM1075)*. It is recommended to power the board (5V_VIN) before plugging the USB debug cable to the Micro-B connector.

Figure 6. CN11 ST-LINK USB Micro-B connector pinout

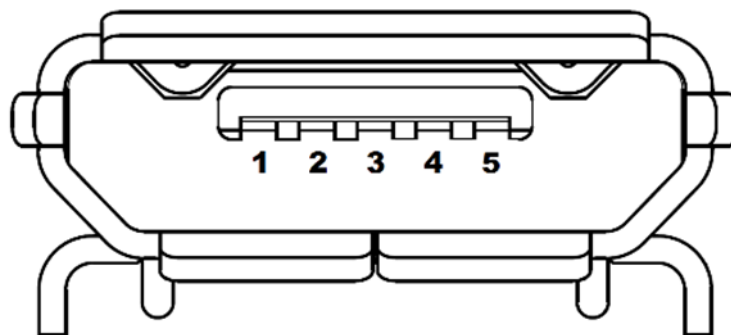

Table 4. CN11 ST-LINK USB Micro-B connector pinout

Pin	Pin name	Signal name	ST-LINK STM32 pin	Function
1	VBUS	5V_USB_ST_LINK	-	VBUS Power
2	DM	USB_STLK_N	PA11	DM
3	DP	USB_STLK_P	PA12	DP
4	ID	-	GND	ID
5	GND	GND	GND	GND

7.1.2 Drivers

Before connecting STM32MP157x-DKx to a Windows® (7, 8, or 10) PC via the USB, a driver for ST-LINK/V2-1 must be installed (not required for Windows® 10). It is available from the www.st.com website.

In case the STM32MP157x-DKx Discovery kit is connected to the PC before the driver is installed, some Discovery kit interfaces may be declared as “Unknown” in the PC device manager. In this case, the user must install the dedicated driver files, and update the driver of the connected device from the device manager.

7.1.3 ST-LINK/V2-1 firmware upgrade

The ST-LINK/V2-1 embeds a firmware upgrade mechanism for in-situ upgrade through the USB port. As firmware may evolve during the lifetime of the ST-LINK/V2-1 product (addition of new functionalities, bug fixes, or support of new microprocessor families), it is recommended to visit periodically the www.st.com website before starting to use the STM32MP157x-DKx Discovery kit to stay up-to-date with the latest firmware version.

7.2 Power supply

7.2.1 5 V power supply

The STM32MP157x-DKx Discovery kit is designed to be powered by a 5 V DC power source at 3 A maximum such as:

- 5V_VBUS connected to the CN6 connector through a USB Type-C® to USB Type-C® cable
 - The two lines USB_PWR_CC1 and USB_PWR_CC2 are connected to PA4 and PA5 respectively to check what is connected to CN6 and control features enabling:
 - Legacy cable
 - Personal computer
 - 5 V DC power source at 3 A

Depending on the current needed on the devices connected to the USB port, and the board itself, power limitations can prevent the system from working as expected. The user must ensure that the STM32MP157x-DKx Discovery kit is supplied with the correct power source depending on the current needed. It is recommended to use a USB Type-C® to USB Type-C® 5 V/3 A charger.

7.2.2 STPMIC1 power supply

For general information concerning the STPMIC1, refer to the datasheet on the www.st.com website.

STPMIC1 supply

- VDD_CORE (BUCK1) used to supply the core of the STM32MP157x
 - Value: 1.2 V
- VDD_DDR (BUCK2) used to supply the DDR core and I/Os
 - Value: 1.35 V
- VDD (BUCK3) used to supply the VDDA and VDD domains of the STM32MP157x
 - Value: 3.3 V
- 3V3 (BUCK4) used to provide the 3.3 V to the different features available on the Discovery kit
 - Value: 3.3 V
- VREF_DDR used to supply the DDR reference voltage
 - Value: 1.65 V

- VTT_DDR (LDO3) used to supply the termination resistors of the DDR
 - Value: 1.65 V
- 1V8_Audio (LDO1) used to supply the digital/analog of the audio codec
 - Value: 1.8 V
- 1V2_HDMI (LDO6) used to supply the digital core and analog part of the HDMI transceiver
 - Value: 1.2 V
- 3V3_HDMI (LDO2) used to supply the I/Os of the HDMI transceiver
 - Value: 3.3 V
- VDD_USB (LDO4) used to supply the USB phy of the STM32MP157x
 - Value: 3.3 V

7.3 Clock sources

7.3.1 LSE clock references

The LSE clock references on the STM32MP157x microprocessor are provided by the external crystal X2:

- 32.768 kHz crystal from NDK: reference NX2012SA

7.3.2 HSE clock references

The HSE clock references on the STM32MP157x microprocessor are provided by the external crystal X6:

- 24 MHz crystal from NDK: reference NX2016SA

7.4 Reset sources

The reset signal of STM32MP157x-DKx is active low. The internal PU forces the RST signal to a high level. The sources of reset are:

- Reset button B2 (black button)
- STPMIC1
- Embedded ST-LINK/V2-1
- ARDUINO® connector CN16: pin 3, reset from the ARDUINO® board
- STM32MP157x

7.5 Boot mode

7.5.1 Description

At startup, the boot source used by the internal bootROM is selected by the Boot pins. [Table 5](#) describes the configurations of the Boot pins.

Table 5. Boot mode pins

Boot 0	Boot 1 ⁽¹⁾	Boot 2	Boot mode
0	0	0	Forced USB boot for flashing.
1	0	0	Not supported.
0	0	1	Engineering boot.
1	0	1	SD card on SDMMC1.

1. Pin Boot 1 is always tied to "0" by a pull-down resistor.

[Figure 7](#) shows the configurations of the boot-related switch SW1.

Figure 7. Boot-mode switch SW1

 Forced USB boot
 for flashing

Engineering boot

Boot from SD card

7.6 Audio

7.6.1 Description

The CS42L51-CNZ codec is connected through an SAI interface to the STM32MP157x microcontroller. This component supports the TDM feature of the SAI port. The TDM feature offers STM32MP157x the capability to stream stereo audio channels.

7.6.2 Operating voltage

The audio codec has two power supplies:

- VL, connected to the 3.3 V provided by the STPMIC1
- 1V8_AUDIO, dedicated 1.8 V source provided by the STPMIC1

7.6.3 Audio codec interface

Audio codec interfacing is performed through the SAI2 and I2C1 interfaces of the STM32MP157x.

Table 6 describes the I/O configuration of the audio codec interface.

Table 6. I/O configuration for the audio interface

I/O	Configuration
PG9	PG9 used as AUDIO RESETN (active LOW)
PE0	PE0 used as SAI2_MCLKA
PF11	PF11 used as SAI2_SDB shared with GPIO expansion
PI7	PI7 used as SAI2_FSA shared with GPIO expansion
PI5	PI5 used as SAI2_SCKA shared with GPIO expansion
PI6	PI6 used as SAI2_SDA shared with GPIO expansion
PD12	PD12 used as I2C1_SCL shared between USB, DSI, HDMI
PF15	PB7 used as I2C1_SDA shared between USB, DSI, HDMI

7.6.4 Headphone outputs

The STM32MP157D-DK1 and STM32MP157F-DK2 Discovery kits can drive a stereo headphone. The STM32MP157x sends the stereo audio channels to the codec via its SAI2 TDM port. The codec converts the digital audio stream to stereo analog signals. It then boosts them for direct drive of the headphone connected to the CN10 3.5 mm stereo jack receptacles on the board.

The audio codec is set by an I²C bus. The address is a 7 bit address plus one bit for read/write (high for read, low for write). The AD0 pin, connected to GND, gives the least-significant address bit. The address of the audio codec is 0b1001010x: 0x94 to write and 0x95 to read.

7.6.5 Audio jack connector

Figure 8 shows the CN10 audio jack connector pinout.

Figure 8. CN10 audio jack connector pinout

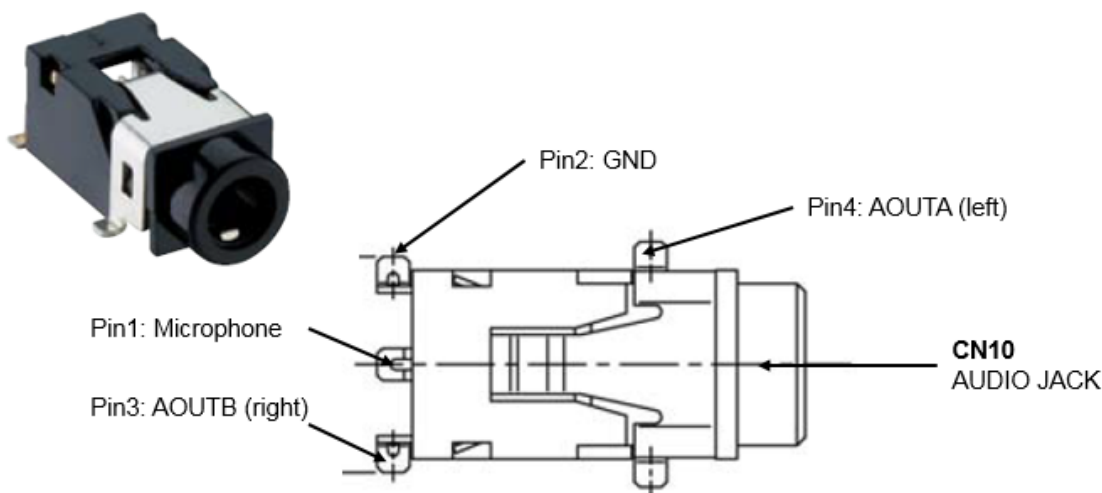

Table 7 describes the CN10 audio jack connector pinout.

Table 7. CN10 audio jack connector pinout

Pin	Pin name	Signal name	Codec pin	Function
1	1	MIC_IN	MICIN1	Microphone IN
2	2	GND	GND	GND
3	3	AOUTB	AOUTB	OUT_SPEAKER_RIGHT
4	4	AOUTA	AOUTA	OUT_SPEAKER_LEFT

7.6.6 I/O restriction

SAI2 is shared between the audio codec and the GPIO expansion connector. By default, the audio codec is available because of solder bridges SB13, SB14, SB15, and SB16.

7.7 USB Host

7.7.1 Description

The STM32MP157D-DK1 and STM32MP157F-DK2 Discovery kits provide four USB Host ports (dual-USB sockets CN1 and CN5) through the use of the USB2514B-AEZC USB Hub. The USB2514B-AEZC has a full power management for each USB port: no I/O is needed from the STM32MP157x.

7.7.2 USB Host interface

Table 8 describes the I/O configuration for the USB Host interface.

Table 8. I/O configuration for the USB Host interface

I/O	Configuration
PD12	PD12 used as I2C1_SCL shared between AUDIO, DSI, and HDMI ⁽¹⁾
PF15	PF15 used as I2C1_SDA shared between AUDIO, DSI, and HDMI ⁽¹⁾
USB_DP1	USB1_P
USB_DM1	USB1_N

1. I2C1 not connected by default (SB7 and SB8 OFF).

Figure 9 shows the CN1 and CN5 USB Type-A connector pinout.

Figure 9. CN1 and CN5 USB Type-A connector pinout

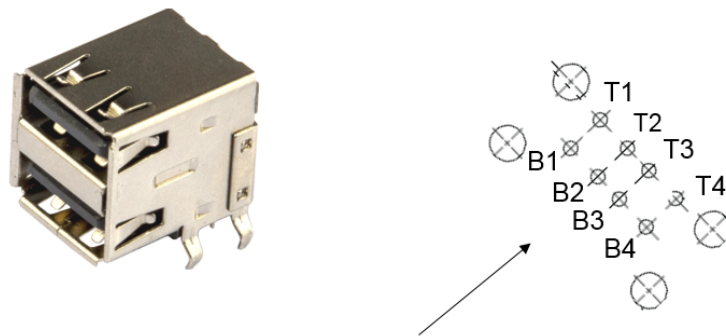

Table 9 describes CN1 and CN5 USB Host connector pinout.

Table 9. CN1 and CN5 USB Host connector pinout

Pin	Pin name	Signal name	Function
CN1			
T1	T1	VBUS	VBUS
T2	T2	USB1CN25_N	DM
T3	T3	USB1CN25_P	DP
T4	T4	GND	GND
B1	B1	VBUS	VBUS
B2	B2	USB1CN25_N	DM
B3	B3	USB1CN25_P	DP
B4	B4	GND	GND
CN5			
T1	T1	VBUS	VBUS
T2	T2	USB1CN26_N	DM

Pin	Pin name	Signal name	Function
T3	T3	USB1CN26_P	DP
T4	T4	GND	GND
B1	B1	VBUS	VBUS
B2	B2	USB1CN26_N	DM
B3	B3	USB1CN26_P	DP
B4	B4	GND	GND

7.8 USB Type-C™ HS

7.8.1 Description

The STM32MP157D-DK1 and STM32MP157F-DK2 Discovery kits support USB high-speed (HS) communication. USB connector CN7 is a USB Type-C™ connector.

The STM32MP157D-DK1 and STM32MP157F-DK2 Discovery kits support USB Type-C™ Source mode.

7.8.2 Operating voltage

The STM32MP157D-DK1 and STM32MP157F-DK2 Discovery kits support 5 V USB voltage from 4.75 V to 5.25 V.

7.8.3 USB HS Source

When a *USB Device* connection to the CN7 USB Type-C™ connector of STM32MP157D-DK1 or STM32MP157F-DK2 is detected, the Discovery kit starts behaving as a *USB Host*.

7.8.4 USB Type-C® connector

Figure 10 shows the pinout of USB Type-C® connector CN7.

Figure 10. CN7 USB Type-C® connector pinout

A1	A2	A3	A4	A5	A6	A7	A8	A9	A10	A11	A12
GND	TX1+	TX1-	VBUS	CC1	D+	D-	SBU1	VBUS	RX2-	RX2+	GND
GND	RX1+	RX1-	VBUS	SBU2	D-	D+	CC2	VBUS	TX2-	TX2+	GND
B12	B11	B10	B9	B8	B7	B6	B5	B4	B3	B2	B1

Table 10 describes the pinout of USB Type-C® connector CN7.

Table 10. CN7 USB Type-C® connector pinout

Function	STM32 pin	Signal name	Pin name	Pin	Pin	Pin name	Signal name	STM32 pin	Function
GND	-	GND	GND	A1	B12	GND	GND	-	GND
TX1+	-	-	TX1+	A2	B11	RX1+	-	-	RX1+
TX1-	-	-	TX1-	A3	B10	RX1-	-	-	RX1-
VBUS	-	-	VBUS	A4	B9	VBUS	-	-	VBUS
CC1	-	-	CC1	A5	B8	SBU2	-	-	SBU2
D+	USB_DP2	USB_DP2	D+	A6	B7	D-	USB_DM2	USB_DM2	D-

Function	STM32 pin	Signal name	Pin name	Pin	Pin	Pin name	Signal name	STM32 pin	Function
D-	USB_DM2	USB_DM2	D-	A7	B6	D+	USB_DP2	USB_DP2	D+
SBU1	-	-	SBU1	A8	B5	CC2	-	-	CC2
VBUS	-	-	VBUS	A9	B4	VBUS	-	-	VBUS
RX2-	-	-	RX2-	A10	B3	TX2-	-	-	TX2-
RX2+	-	-	RX2+	A11	B2	TX2+	-	-	TX2+
GND	-	GND	GND	A12	B1	GND	GND	-	GND

7.9 microSD™ card

7.9.1 Description

The CN15 slot for the microSD™ card is routed to STM32MP157x SDIO port (SDMMC1). This interface is compliant with *SD Memory Card Specification Version 3.01: SDR50*.

7.9.2 Operating voltage

The microSD™ card interface is only compatible with the 3.3 V voltage range: from 2.7 V to 3.6 V. All microSD™ card types are supported (including SDHC and SDXC), but only Default and High-Speed modes (3 V) are supported on STM32MP157D-DK1 and STM32MP157F-DK2. UHS-I modes (1.8 V) are not supported on these Discovery kits.

7.9.3 microSD™ card interface

The microSD™ card interface is used in the four data lines D[0:3] with one clock (CLK), one command line (CMD), and one card detection signal (CARD_DETECT).

The SDMMC1 is a bootable interface.

Table 11 describes the I/O configuration for the SDIO interface.

Table 11. I/O configuration for the SDIO interface

I/O	Configuration
PB7	PB7 is connected to μ SD_DETECT
PC8	PC8 is connected to SDMMC1_D0
PC9	PC9 is connected to SDMMC1_D1
PC10	PC10 is connected to SDMMC1_D2
PC11	PC11 is connected to SDMMC1_D3
PC12	PC12 is connected to SDMMC1_CLK
PD2	PD2 is connected to SDMMC1_CMD

Figure 11 shows the pinout of the microSD™ connector CN15.

Figure 11. microSD™ card connector CN15

Table 12 describes pinout of the microSD™ connector CN15.

Table 12. CN15 microSD™ connector pinout

Pin	Pin name	Signal name	STM32 pin	Function
1	DAT2	SDMMC1_D2	PC10	SDIO.D2
2	DAT3_CD	SDMMC1_D3	PC11	SDIO.D3
3	CMD	SDMMC1_CMD	PD2	SDIO.CMD
4	3V3	3V3	-	VDD_SDCARD
5	CLK	SDMMC1_CLK	PC12	SDIO.CLK
6	VSS	GND	-	GND
7	DAT0	SDMMC1_D0	PC8	SDIO.D0
8	DAT1	SDMMC1_D1	PC9	SDIO.D1
9	GND	GND	-	GND
10	CARD_DETECT	uSD_DETECT	PB7	SDCARD_DETECT active LOW

7.10 LEDs

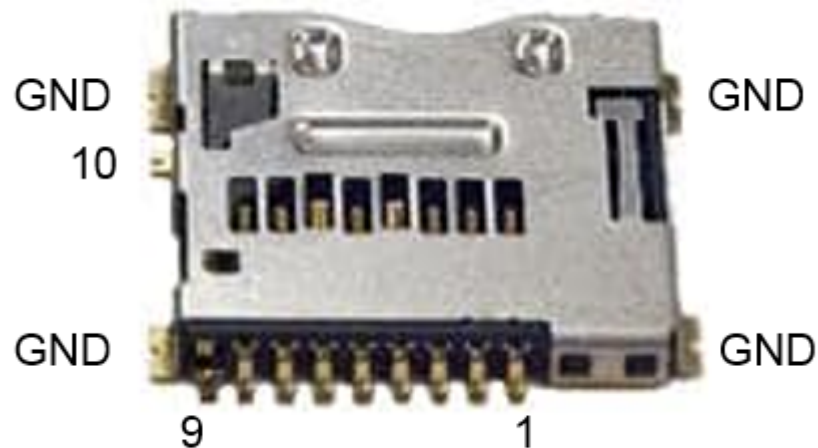
7.10.1 Description

The LD2 LED turns green when the power cable is inserted in connector CN6.

Two general-purpose color LEDs (LD7 and LD8) are available as light indicators:

- The LD7 orange LED is used as STM32Cube examples verdict LED.
- The LD8 blue LED is used as Linux® Heartbeat LED, which is blinking as long as Linux® is alive on the Cortex®-A.

The two user LEDs, the green LD5 and orange LD6 LEDs, are directly connected to the STM32MP157x.

7.10.2 Operating voltage

All LEDs are driven by the I/O level; they are operating in the 3.3 V voltage range.

7.10.3 LED interface

Table 13 describes the I/O configuration of the LED interface.

Table 13. I/O configuration of the LED interfaces

I/O	Configuration
PA14	PA14 is connected to the green LED LD4. Active Low.
PA13	PA13 is connected to the red LED LD6. Active Low.
PH7	PH7 is connected to the orange LED LD7. Active High.
PD11	PD11 is connected to the blue LED LD8. Active High.

7.11 Buttons

7.11.1 Description

The STM32MP157D-DK1 and STM32MP157F-DK2 Discovery kits provide four types of buttons:

- Wake-up button (B1)
 - Allows the platform to be woken up from any low-power mode
 - Connected to STPMIC1 PONKEY, which generates a wake up signal on STM32MP157x PA0
- Reset button (B2)
 - Used to reset the Discovery kit
- USER1 button (B3)
 - Used at boot time by U-Boot to enter the USB programming mode
- USER2 button (B4)
 - Used at boot time by U-Boot to enter the Android® Fastboot mode

7.11.2 I/O interface

Table 14 describes the I/O configuration for the physical user interface.

Table 14. I/O configuration for the physical user interface

I/O	Configuration
NRST	Reset button (B2). Active Low.
-	Wake-up button (B1). Connected to the PONKEYn pin of the STPMIC1
PA13	USER2 user button (B4)
PA14	USER1 user button (B3)

7.12 HDMI®

7.12.1 Description

The STM32MP157D-DK1 and STM32MP157F-DK2 Discovery kits offer an HDMI® connection for a TV monitor through the use of the Lattice Semiconductor SiI9022A HDMI® transmitter.

The resolution is up to 720p60 (1280 × 720).

Input signals are 24 bits digital RGB (LTDC) for the video and I2S2 for the audio. Refer to the STM32MP157x datasheet for details.

The control signals are I2C1, one interruption, and a dedicated reset.

The Consumer Electronic Control (CEC) is also available through the HDMI® transmitter (transmitter bypassed).

7.12.2

HDMI® I/O interface

Table 15 describes the I/O configuration for the HDMI® interface.

Table 15. I/O configuration for the HDMI® interface

I/O	Configuration
PB6	PB6 is connected to HDMI_CEC.
PD9	PD9 is connected to LTDC_B0.
PG12	PG12 is connected to LTDC_B1.
PG10	PG10 is connected to LTDC_B2.
PD10	PD10 is connected to LTDC_B3.
PI4	PI4 is connected to LTDC_B4.
PA3	PA3 is connected to LTDC_B5.
PB8	PB8 is connected to LTDC_B6.
PD8	PD8 is connected to LTDC_B7.
PE5	PE5 is connected to LTDC_G0.
PE6	PE6 is connected to LTDC_G1.
PH13	PH13 is connected to LTDC_G2.
PH14	PH14 is connected to LTDC_G3.
PH15	PH15 is connected to LTDC_G4.
PI0	PI0 is connected to LTDC_G5.
PI1	PI1 is connected to LTDC_G6.
PI2	PI2 is connected to LTDC_G7.
PH2	PH2 is connected to LTDC_R0.
PH3	PH3 is connected to LTDC_R1.
PH8	PH8 is connected to LTDC_R2.
PH9	PH9 is connected to LTDC_R3.
PH10	PH10 is connected to LTDC_R4.
PC0	PC0 is connected to LTDC_R5.
PH12	PH12 is connected to LTDC_R6.
PE15	PE15 is connected to LTDC_R7.
PG7	PG7 is connected to LTDC_CLK.
PF10	PF10 is connected to LTDC_DE.
PI10	PI10 is connected to LTDC_HSYNC.
PI9	PI9 is connected to LTDC_VSYNC.
PA9	PA9 is connected to I2S2_CK.
PB9	PB9 is connected to I2S2_WS.
PI3	PI3 is connected to I2S2_SDO.

I/O	Configuration
PG1	PG1 is connected to HDMI_INT.
PD12	PD12 is connected to I2C1_SCL (I2C shared).
PF15	PF15 is connected to I2C1_SDA (I2C shared).
PA10	PA10 is connected to HDMI_N_RST

Figure 12 shows the pinout of HDMI® connector CN9.

Figure 12. CN9 HDMI® connector pinout

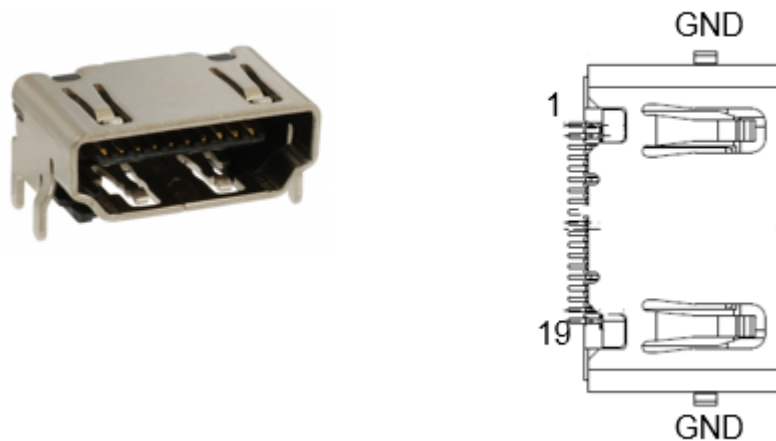

Table 16 describes the pinout of HDMI® connector CN9.

Table 16. CN9 HDMI® connector pinout

Pin	Pin name	Signal name
1	RX2+	TX2C_P
2	GND	GND
3	RX2-	TX2C_N
4	TX1+	TX1C_P
5	GND	GND
6	RX1-	TX1C_N
7	RX0+	TX0C_P
8	GND	GND
9	RX0-	TX0C_N
10	RXC+	TXCC_P
11	GND	GND
12	RXC-	TXCC_N
13	CEC	CEC_A
14	-	-

Pin	Pin name	Signal name
15	SCL	DSCL
16	SDA	DSDA
17	GND	GND
18	+5V	5V_VIN
19	DET	HPD

7.13 Wi-Fi® and Bluetooth® Low Energy

7.13.1 Description

The STM32MP157F-DK2 Discovery kit support Wi-Fi® 802.11b/g/n and Bluetooth® Low Energy (BLE) V4.1. These functions are supported with the LBEE5KL1DX-883 MURATA module. This module is driven by a SDIO for the Wi-Fi® interface, and a USART for the Bluetooth®. The PCM format is used for audio data.

7.13.2 Operating voltage

The LBEE5KL1DX-883 module supports the 3.3 V voltage range.

7.13.3 Wi-Fi® I/O interface

Table 17 describes the I/O configuration for the Wi-Fi® interface.

Table 17. I/O configuration for the Wi-Fi® interface

I/O	Configuration
PB4	PB4 is connected to SDMMC2_D3
PB3	PB3 is connected to SDMMC2_D2
PB15	PB15 is connected to SDMMC2_D1
PB14	PB14 is connected to SDMMC2_D0
PG6	PG6 is connected to SDMMC2_CMD
PE3	PE3 is connected to SDMMC2_CK
PH4	PH4 is connected to WL_REG_ON
PD0	PD0 is connected to WL_HOST_WAKE

7.13.4 Bluetooth® Low Energy I/O interface

Table 18 describes the I/O configuration for the Bluetooth® Low Energy interface.

Table 18. I/O configuration for the Bluetooth® Low Energy interface

I/O	Configuration
PD5	PD5 is connected to USART2_TX
PD6	PD6 is connected to USART2_RX
PD4	PD4 is connected to USART2_RTS
PD3	PD3 is connected to USART2_CTS

I/O	Configuration
PZ3	PZ3 is connected to BT_PCM_WS
PZ2	PZ2 is connected to BT_PCM_SDO
PZ1	PZ1 is connected to BT_PCM_SDI
PZ0	PZ0 is connected to BT_PCM_CK
PZ6	PZ6 is connected to BT_REG_ON
PH5	PH5 is connected to BT_HOST_WAKE
PZ7	PZ7 is connected to BT_DEV_WAKE
PI8	LP0_32

7.14 MIPI DSISM LCD

The LCD is not provided with the STM32MP157D-DK1 Discovery kit.

7.14.1 Description

The 40-pin FCP connector CN4 is used to connect a TFT LCD module through the MIPI DSISM interface supported by the MB1407 board. The touch panel is embedded in the LCD module.

The LCD module is composed of the FRD397B2509V2 TFT LCD module with an OTM8009A LCD driver. The 4" LCD supports a resolution of 480 × 800 dots in 16.7 M colors (RGB). The touch-sensitive panel drive is performed by the FT6236 self-capacitive controller.

Figure 13 shows the LCD connection to MB1407 and MB1272.

Figure 13. LCD connection to MB1407

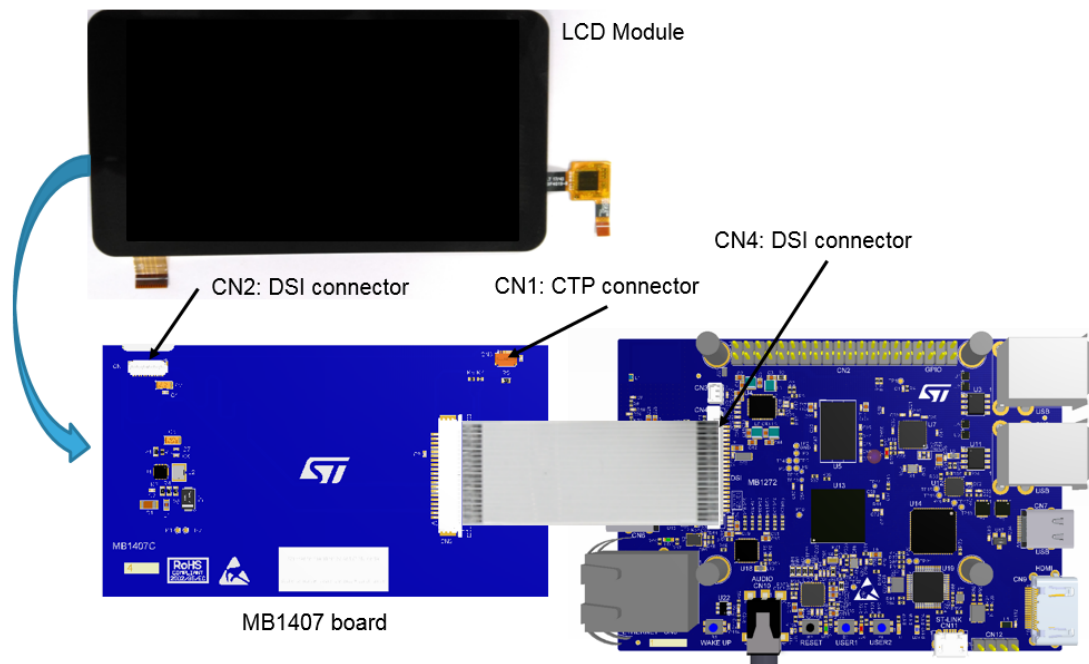

7.14.2 Operating voltage

The LCD module power supply is connected to VDD_3V3.

The touch panel power supply is connected to VDD_3V3.

The backlight of the LCD is driven by the STLD40DPUR circuit on the MB1407 board connected to VDD_3V3.

7.14.3 LCD interface

Table 19 describes the I/O configuration of the LCD and CTP interfaces.

Table 19. I/O configuration of the LCD and CTP interfaces

I/O	Configuration
DSI_D0P	DSI_D0P is used as MIPI-DSI data Lane 0 positive.
DSI_D0N	DSI_D0N is used as MIPI-DSI data Lane 0 negative.
DSI_D1P	DSI_D1P is used as MIPI-DSI data Lane 1 positive.
DSI_D1N	DSI_D1N is used as MIPI-DSI data Lane 0 negative.
DSI_CKP	DSI_CKP is used as clock Lane positive.
DSI_DKN	DSI_DKN is used as clock Lane negative.
PF2	PF2 is used LCD interrupt lane.
PA15	PA15 is used as DSI backlight control. ⁽¹⁾
PD12	PD12 used as I2C1_SCL for the touch panel, shared between USB, AUDIO, HDMI.
PF15	PF15 used as I2C1_SDA for the touch panel, shared between USB, AUDIO, and HDMI.

1. Not used. In the default configuration, backlight control is done by the LCD driver.

Figure 14 shows the the pinout of LCD connector CN4.

Figure 14. CN4 LCD connector pinout

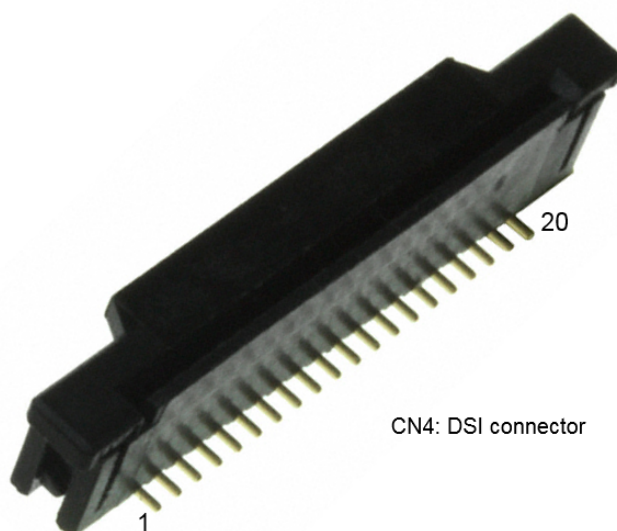

Table 20 describe the LCD interface and pinout of LCD connector CN4.

Table 20. LCD interface and CN4 connector pinout

Pin	STM32 pin	Signal name	Function
1	-	GND	GND
2	DSI_D1N	DSI_D1_N	D1N
3	DSI_D1P	DSI_D1_P	D1P
4	-	GND	GND
5	DSI_CKN	DSI_CK_N	CKN
6	DSI_CKP	DSI_CK_P	CKP
7	-	GND	GND
8	DSI_D0N	DSI_D0_N	D0N
9	DSI_D0P	DSI_D0_P	D0P
10	-	GND	GND
11	PF0	I2C1_SCL	SCL
12	PF14	I2C1_SDA	SDA
13	-	GND	GND
14	-	3V3	3V3
15	-	3V3	3V3
16	-	GND	GND
17	PF2	LCD_INT	INT
18	PC6	DSI_TE	TE
19	PA15	LCD_BL_CTRL	CTRL
20	PE4	DSI_RESET	RESET

7.15 Gigabit Ethernet

7.15.1 Description

The STM32MP157D-DK1 and STM32MP157F-DK2 Discovery kits provide a Gigabit reduced medium-independent interface (RGMII).

The STM32MP157x requires an external physical interface device (PHY). The Realtek RTL8211F-CG is the PHY on the Discovery kits. The PHY is connected to the physical LAN bus using 13 signals for RGMII. It can be clocked using the 25 MHz from the STM32MP157x or from a crystal (X2). The default configuration is 25 MHz from the X2 crystal.

LED LD3 is blinking to indicate the data transmission.

For more details about the PHY (such as clocking or configuration), refer to the datasheet of the Realtek RTL8211F-CG.

7.15.2 Operating voltage

The Ethernet PHY is supplied directly with 3.3 V. It generates its own 1.05 V supply and digital/analog 3.3 V.

7.15.3 Ethernet interface

Table 21 describes the I/O configuration of the Ethernet interface.

Table 21. I/O configuration of the Ethernet interface

I/O	Configuration
PG0	PG0 is used as ETH_NRST active Low.
PA2	PA2 is used as ETH_MDIO.
PA6	PA6 is used as ETH_MDINT.
PC1	PB11 is used as ETH_MDC.
PA7	PA7 is used as ETH_RX_DV.
PC4	PB11 is used as ETH_RXD0.
PC5	PB11 is used as ETH_RXD1.
PB0	PB0 is used as ETH_RXD2.
PB1	PB1 is used as ETH_RXD3.
PB11	PB11 is used as ETH_TX_EN.
PG13	PG13 is used as ETH_TXD0.
PG14	PG14 is used as ETH_TXD1.
PC2	PB11 is used as ETH_TXD2.
PE2	PE2 is used as ETH_TXD3.
PA1	PA1 is used as ETH_RX_CLK.
PG4	PG4 is used as ETH_GTX_CLK.
PG5	PG5 is used as ETH_CLK125.
PB5	PB5 is used as ETH_CLK not the default configuration.

Figure 15 shows the pinout of Ethernet connector CN8.

Figure 15. CN8 Ethernet connector pinout

Table 22. CN8 Ethernet connector pinout

Pin	Pin name	Function
1	TX1+	First bidirectional pair to transmit and receive data.
2	TX1-	
3	TX2+	Second bidirectional pair to transmit and receive data.
4	TX2-	
5	CT1	Common connected to GND.
6	CT2	Common connected to GND.
7	TX3+	Third bidirectional pair to transmit and receive data.
8	TX3-	
9	TX4+	Fourth bidirectional pair to transmit and receive data.
10	TX4-	
11	GA	Green LED anode.
12	GC	Green LED cathode.
13	YA	Yellow LED anode.
14	YC	Yellow LED cathode.
15	GND	GND.
16	GND	GND.

7.16 ARDUINO® connectors

7.16.1 Description

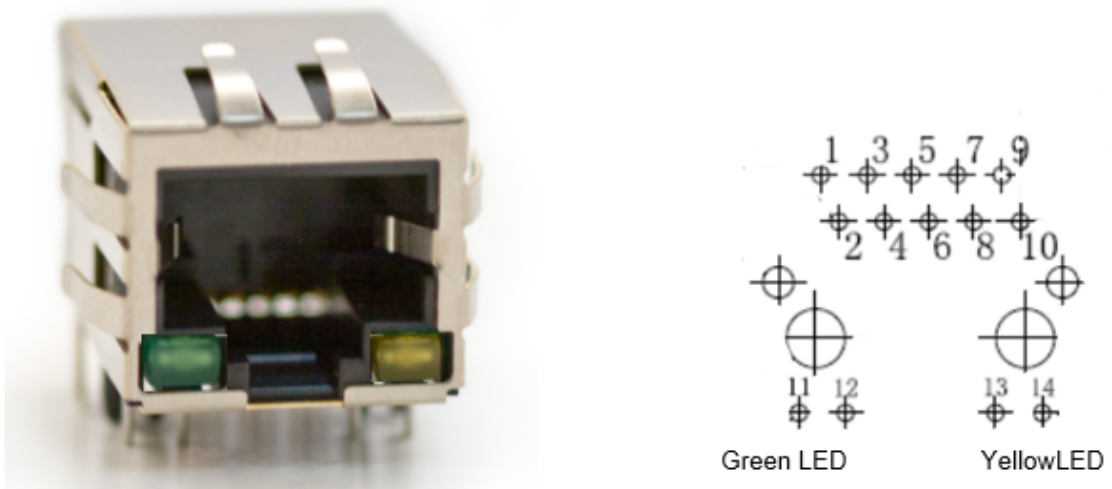
The ARDUINO® Uno V3 connectors (CN13, CN14, CN16, and CN17) are available on the STM32MP157x-DKx Discovery kit. Most shields designed for ARDUINO® can fit with the Discovery kit to offer flexibility in small form factor applications.

7.16.2 Operating voltage

The ARDUINO® Uno V3 connectors support 5 V, 3.3 V, and VDD for I/O compatibility.

Caution: Do not supply 3.3 V or 5 V from the ARDUINO® shield. Supplying 3.3 V or 5 V from the ARDUINO® shield could damage the Discovery kit.

7.16.3 ARDUINO® interface

Figure 16 shows the pinout of the ARDUINO® connectors.

Figure 16. ARDUINO® connectors pinout

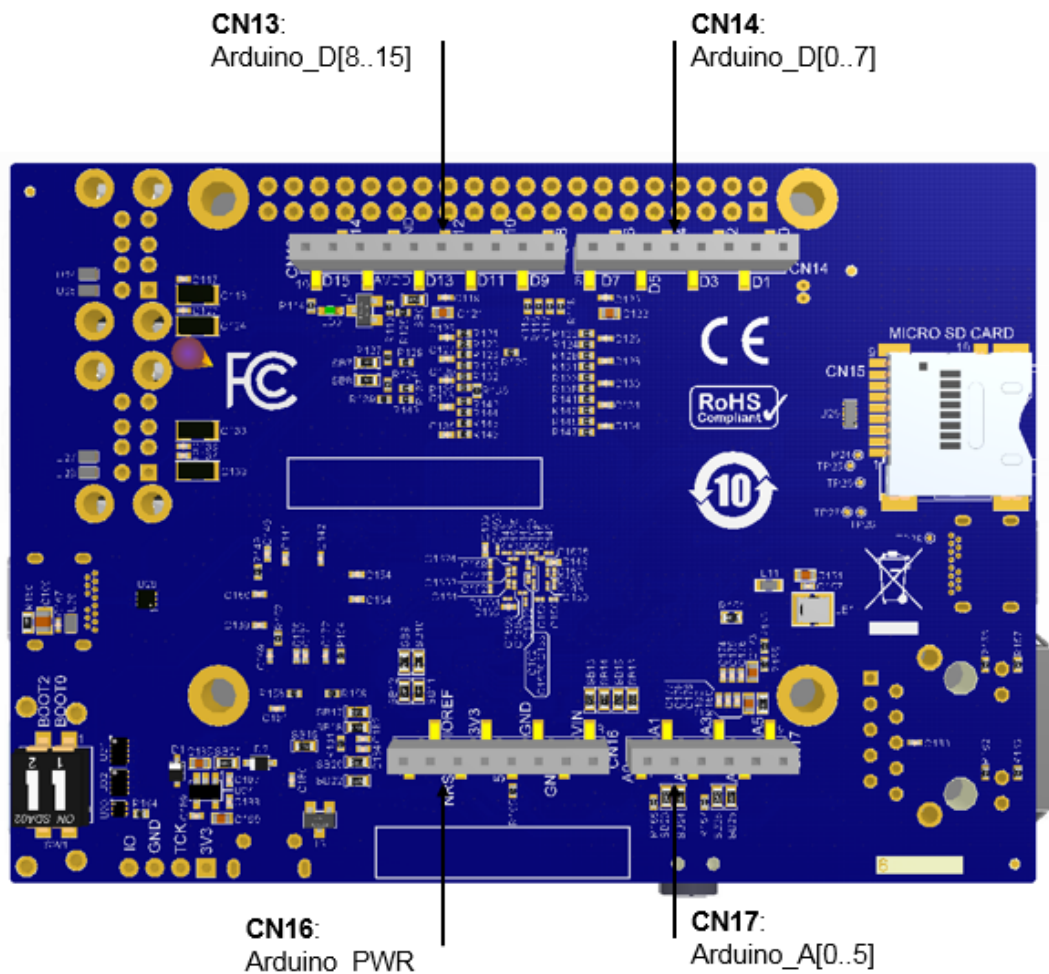

Table 23 describes the I/O configuration of the ARDUINO® interface.

Table 23. I/O configuration of the ARDUINO® interface

I/O	HW	Configuration
PF14	-	PF14 is used as ARD_A0: ADC1_IN0
PF13	-	PF13 is used as ARD_A1: ADC1_IN1
ANA0	-	ANA0 is used as ARD_A2: ADC1_IN6
ANA1	-	ANA1 is used as ARD_A3: ADC1_IN2
PC3	SB24 ON	PC3 is used as ARD_A4: ADC1_IN13 Default configuration
PF12	SB26 ON	PF12 is used as ARD_A5: ADC1_IN14 Default configuration
PE7	-	PE7 is used as ARD_D0: UART7_RX
PE8	-	PE8 is used as ARD_D1: UART7_TX
PE1	-	PE1 is used as ARD_D2: IO
PD14	-	PD14 is used as ARD_D3: TIM4_CH3
PE10	-	PE10 is used as ARD_D4: IO

I/O	HW	Configuration
PD15	-	PD15 is used as ARD_D5: TIM4_CH4
PE9	-	PE9 is used as ARD_D6: TIM4_CH1
PD1	-	PD1 is used as ARD_D7: IO
PG3	-	PG3 is used as ARD_D8: IO
PH6	-	PH6 is used as ARD_D9: TIM12_CH1
PE11	-	PE11 is used as ARD_D10: SPI4_NSS, TIM1_CH2
PE14	-	PE14 is used as ARD_D11: SPI4_MOSI ,TIM1_CH4
PE13	-	PE13 is used as ARD_D12: SPI4_MISO
PE12	-	PE12 is used as ARD_D13: SPI4_SCK
PA12	-	PA12 used as ARD_D14: I2C5_SDA shared with ARD_A4 (SB23 ON / SB24 OFF)
PA11	-	PA11 used as ARD_D15: I2C5_SCL shared with ARD_A5 (SB25 ON / SB26 OFF)

Table 24 describes the pinout of the ARDUINO® connectors.

Table 24. Pinout of the ARDUINO® connectors

Connector	Pin name	Signal name	STM32 pin	Comment
CN16	1	NC	-	NC (reserved for test)
	2	3V3	-	IOREF 3V3
	3	NRST	NRST	NRST
	4	3V3	-	3V3
	5	5V	-	5V
	6	GND	-	GND
	7	GND	-	GND
	8	VIN		Not connected
CN17	1	A0	PF14	ADC1_IN0
	2	A1	PF13	ADC1_IN1
	3	A2	ANA0	ADC1_IN6
	4	A3	ANA1	ADC1_IN2
	5	A4	PC3/PA12	ADC1_IN13
	6	A5	PF12/PA11	
CN14	1	ARD_D0	PE7	USART7_RX
	2	ARD_D1	PE8	USART7_TX
	3	ARD_D2	PE1	IO
	4	ARD_D3	PD14	TIM4_CH3
	5	ARD_D4	PE10	IO
	6	ARD_D5	PD15	TIM4_CH4
	7	ARD_D6	PE9	TIM1_CH1
	8	ARD_D7	PD1	IO
CN13	1	ARD_D8	PG3	IO

Connector	Pin name	Signal name	STM32 pin	Comment
CN13	2	ARD_D9	PH6	TIM12_CH1
	3	ARD_D10	PE11	SPI4_NSS and TIM1_CH2
	4	ARD_D11	PE14	SPI4_MOSI and TIM1_CH4
	5	ARD_D12	PE13	SPI4_MISO
	6	ARD_D13	PE12	SPI4_SCK
	7	GND	-	GND
	8	VREFP	-	VREF+
	9	ARD_D14	PA12	I2C5_SDA
	10	ARD_D15	PA11	I2C5_SCL

7.17 GPIO expansion connectors

7.17.1 Description

- The GPIO pins can be used as GPIOs or alternate functions. The available alternate functions are listed in [Table 25. GPIO connectors pinout](#).
- Other functions such as I²C, UART, or FDCAN can be mapped on the GPIO connectors, for instance using the [STM32CubeMX](#) tool.
- The GPIO expansion connector CN2 offers Raspberry Pi[®] shields capability.

7.17.2 GPIO expansion connector interface

Figure 17 shows the pinout of the GPIO connectors.

Figure 17. GPIO connectors

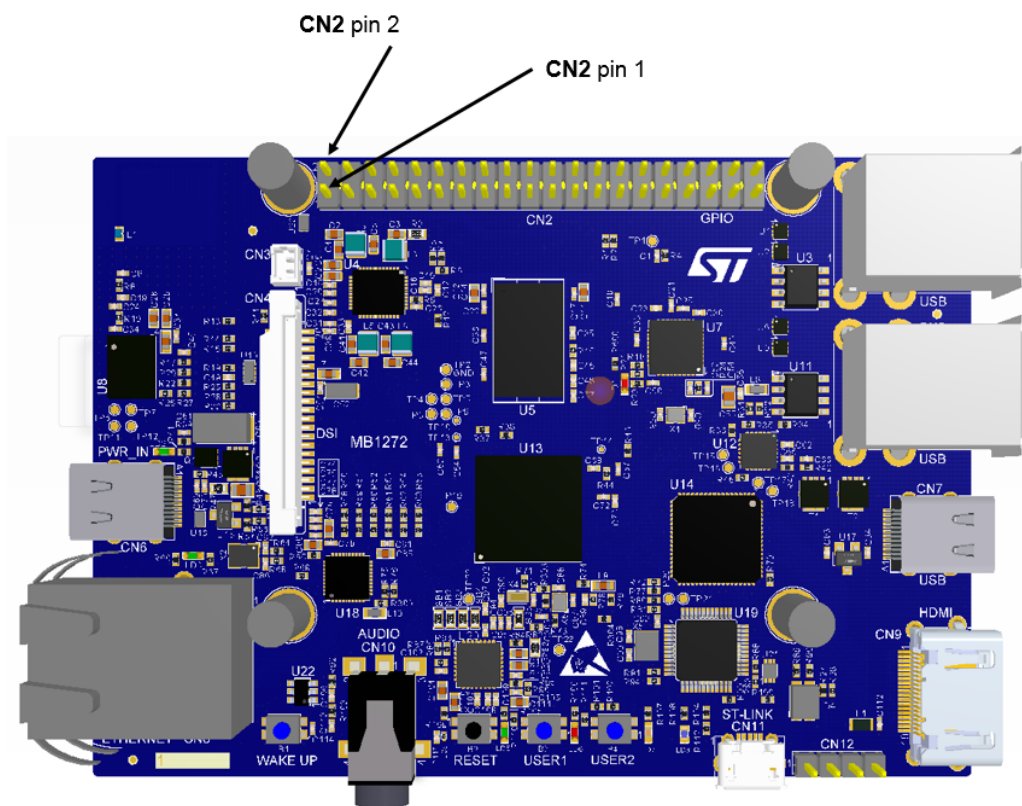

Table 25 describes the pinout of the GPIO connectors.

Table 25. GPIO connectors pinout

Function	STM32 pin	Pin	Pin	STM32 pin	Function
3V3	-	1	2	-	5V
GPIO2 / I2C5_SDA	PA12	3	4	-	5V
GPIO3 / I2C5_SCL	PA11	5	6	-	GND
GPIO4 / MCO1	PA8	7	8	PB10	GPIO14 / USART3_TX
GND	-	9	10	PB12	GPIO15 / USART3_RX
GPIO17 / USART3_RTS	PG8	11	12	PI5	GPIO18 / SAI2_SCKA
GPIO27 / SDMMC3_D3	PD7	13	14	-	GND
GPIO22 / SDMMC3_CK	PG15	15	16	PF1	GPIO23 / SDMMC3_CMD
3V3	-	17	18	PF0	GPIO24 / SDMMC3_D0
GPIO10 / SPI5_MOSI	PF9	19	20	-	GND
GPIO9 / SPI5_MISO	PF8	21	22	PF4	GPIO25 / SDMMC3_D1
GPIO11 / SPI5_SCK	PF7	23	24	PF6	GPIO8 / SPI5_NSS
GND	-	25	26	PF3	GPIO7
I2C1_SDA	PF15	27	28	PD12	I2C1_SCL
GPIO5 / MCO2	PG2	29	30	-	GND

Function	STM32 pin	Pin	Pin	STM32 pin	Function
GPIO6 / TIM5_CH2	PH11	31	32	PD13	GPIO12 / TIM4_CH2
GPIO13 / TIM3_CH2	PC7	33	34	-	GND
GPIO19 / SAI2_FSA	PI7	35	36	PB13	GPIO16 / USART3_CTS
GPIO26 / SDMMC3_D2	PF5	37	38	PI6	GPIO20 / SAI2_SDA
GND	-	39	40	PF11	GPIO21 / SAI2_SDB

7.18 VBAT connector

7.18.1 Description

The voltage on the VBAT pin of the STM32MP157x-DKx can be provided by an external battery. Use connector CN3 to plug a CR2032 battery (3 V lithium battery), wired on Molex 51021-0200, as shown in [Figure 18](#).

Caution: Pin1: VBAT. Pin2: GND.

Figure 18. CN3 VBAT connector

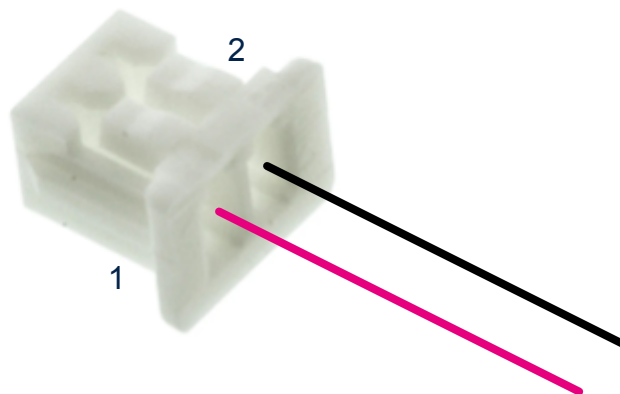

8 STM32MP157x-DKx Discovery kits information

8.1 Identification

The STM32MP157x-DKx product, composed of one or two boards, is identified using the product sticker with an identification as:

- Product name
- Sales type
- FCC ID

Each board is further identified with its own dedicated board sticker.

The sticker located on the top or bottom side of the PCB board shows the information about product identification such as board reference, revision, and serial number.

The first identification line has the following format: "MBxxxx-Variant-yzz", where "MBxxxx" is the board reference, "Variant" (optional) identifies the mounting variant when several exist, "y" is the PCB revision and "zz" is the assembly revision: for example B01.

The second identification line is the board serial number used for traceability.

Evaluation tools marked as "ES" or "E" are not yet qualified and therefore not ready to be used as reference design or in production. Any consequences deriving from such usage will not be at ST charge. In no event, ST will be liable for any customer usage of these engineering sample tools as reference designs or in production.

"E" or "ES" marking examples of location:

- On the targeted STM32 that is soldered on the board (For an illustration of STM32 marking, refer to the STM32 datasheet "Package information" paragraph at the www.st.com website).
- Next to the evaluation tool ordering part number that is stuck or silk-screen printed on the board.

The product and board stickers are detailed in [Table 26](#).

Table 26. Product and board stickers

Product / board	Sticker information
Product	STM32MP157D-DK1 or STM32MP157F-DK2 DK32MP157D1\$AU1 or DK32MP157F2\$AU1 Contains FCC ID: VPYLB1DX ⁽¹⁾
MB1272 board	MB1272-DK1-C02 or MB1272-DK2-C02 syywwxxxxx
MAC address	00:80:E1:XX:XX:XX
MB1407 board	MB1407-LCD-C02 ⁽¹⁾ syywwxxxxx

1. Only for STM32MP157F-DK2.

8.2 Product revision history

STM32MP157D-DK1 DK32MP157D1\$AU1 and STM32MP157F-DK2 DK32MP157F2\$AU1 are the initial released versions.

8.3 Known limitations

None.

9 STM32MP157x-DKx I/O assignment

Table 27. Discovery kit I/O assignment

Ball	Pin	Assignment
A2	PH5	BT_HOST_WAKE
C2	PH10	LTDC_R4
B2	PH12	LTDC_R6
D1	PH13	LTDC_G2
C3	PH14	LTDC_G3
B1	PH15	LTDC_G4
C1	PI0	LTDC_G5
E3	PI1	LTDC_G6
E2	PI2	LTDC_G7
E1	PI3	HDMI_I2S2_MOSI
E4	PI4	LTDC_B4
F3	PI5	SAI2_SCKA
F4	PI6	SAI2_SDA
F2	PI7	SAI2_FSA
G1	PZ1	BT_PCM_1_SDI
G4	PZ3	BT_PCM_1_WS
H4	PI9	LTDC_VSYNC
G3	PZ0	BT_PCM_1_CK
J4	PZ2	BT_PCM_1_SDO
G2	PZ4	PMIC_I2C4_SCL
K4	PG12	LTDC_B1
H2	PZ5	PMIC_I2C4_SDA
H1	PZ6	BT_REG_ON
J3	PZ7	BT_DEV_WAKE
D2	PD6	BT_USART2_RX
L3	PD14	ARDUINO_D3_TIM4_CH3
J2	PD15	ARDUINO_D5_TIM4_CH4
K3	PD8	LTDC_B7
K1	PD9	LTDC_B0
L4	PI8	LPO_32OUT2
K2	PC13	PC13_ANTI_TAMP_PMIC_WAKEUP
N2	PA13	LED1_GPIO
T2	PA14	LED2_GPIO
P4	PI11	PI11_STUSB1600_IRQN_WKUP5
T1	PI10	LTDC_HSYNC
W4	PH7	LED_Y_GPIO
U1	PF3	GPIO7_GPIO

Ball	Pin	Assignment
W2	PC3	ARDUINO_A4_ADC1_IN13
T4	PG3	ARDUINO_D8_GPIO
Y1	PE2	ETH_TXD3
U2	PA3	LTDC_B5
Y2	PC2	ETH_TXD2
V2	PG2	GPIO5_MCO2
AA1	PG14	ETH_TXD1
W1	PG1	HDMI_INT_GPIO
AA2	PG13	ETH_TXD0
U3	ANA0	ARDUINO_A0_ADC1_IN0
AB3	PA0	PA0_WKUP_PMIC_INT
U4	ANA1	ARDUINO_A1_ADC1_IN1
AA4	PA1	ETH_REF_CLK
V3	PA5	TypeC_Power_CC2_ADC1_IN19
V4	PA4	TypeC_Power_CC1_ADC1_IN18
AB1	PB11	ETH_TX_EN
AB2	PG4	ETH_GTX_CLK
AC3	PA2	ETH_MDIO
AA6	PC1	ETH_MDC
Y6	PG5	ETH_CLK125
AA3	PH3	LTDC_R1
AB6	PB0	ETH_RXD2
Y4	PF15	IDSD_BOARD_I2C1_SDA
AA7	PB1	ETH_RXD3
AC4	PF14	ARDUINO_A2_ADC2_IN6
Y5	PF13	ARDUINO_A3_ADC2_IN2
AB4	PH2	LTDC_R0
AB7	PC5	ETH_RXD1
AC7	PC4	ETH_RXD0
Y9	PF12	ARDUINO_A5_ADC1_IN6
Y10	PF11	SAI2_SD_B
AB8	PA7	ETH_RXDV
AC8	PA6	ETH_MDINT
AB5	PC0	LTDC_R5
Y3	PB10	GPIO14_USART3_TX
AC5	PB12	GPIO15_USART3_RX
AA10	PB13	GPIO16_USART3_CTS_NSS
Y8	PB5	ETH_ETH_CLK
Y7	PG11	STLK_UART4_TX
Y11	PH6	ARDUINO_D9_TIM12_CH1

Ball	Pin	Assignment
AB10	PB8	LTDC_B6
AB9	PG8	GPIO17_USART3_RTS
AB11	PG10	LTDC_B2
AA9	PE9	ARDUINO_D6_TIM1_CH1
AA11	PE7	ARDUINO_D0_UART7_RX
AC10	PD11	LED_B_GPIO
AB12	PF7	GPIO11_SPI5_SCK
AC11	PF8	GPIO9_SPI5_MISO
Y12	PF10	LTDC_DE
AA13	PF6	GPIO8_SPI5_NSS
Y18	PD12	I2C1_SCL
AA14	PF9	GPIO10_SPI5_MOSI
AC14	PG7	LTDC_CLK
Y14	PB6	HDMI_CEC
AC13	PE8	ARDUINO_D1_UART7_TX
Y15	PE10	ARDUINO_D4_GPIO
Y16	PB2	STLK_UART4_RX
AA19	PD13	GPIO12_TIM4_CH2
Y13	PG9	AUDIO_RST
AB19	PA12	ARDUINO_D14_GPIO3_I2C5_SDA
AA18	PA11	ARDUINO_D15_GPIO2_I2C5_SCL
D16	PC11	uSD_SDMMC1_D3
D19	PE4	DSI_RESET_GPIO
D18	PC8	uSD_SDMMC1_D0
D15	PC10	uSD_SDMMC1_D2
B13	PB4	WLAN_SDMMC2_D3
D17	PC9	uSD_SDMMC1_D1
B11	PC7	GPIO13_TIM3_CH2
B14	PC6	DSI_TE
A14	PF2	DSI_LCD_INT_GPIO
D12	PD2	uSD_SDMMC1_CMD
A13	PA8	GPIO4_MCO1
C13	PB14	WLAN_SDMMC2_D0
D13	PC12	uSD_SDMMC1_CK
B12	PB15	WLAN_SDMMC2_D1
C11	PE5	LTDC_G0
A11	PB3	WLAN_SDMMC2_D2
A10	PG6	WLAN_SDMMC2_CMD
D14	PD3	BT_USART2_CTS_NSS
B10	PB9	HDMI_I2S2_NSS/2_WS

Ball	Pin	Assignment
C19	PA15	DSI_LCD_BLCTRL_TIM2_CH1/2_ETR
A8	PA9	HDMI_I2S2_SCK/2_CK
D11	PB7	uSD_detect_GPIO
B9	PD1	ARDUINO_D7_GPIO
B8	PD0	WLAN_HOST_WAKE_GPIO
C9	PE3	WLAN_SDMMC2_CK
A7	PD5	BT_USART2_TX
D10	PD7	GPIO27_SDMMC3_D3
B7	PG15	GPIO22_SDMMC3_CK
C10	PE6	LTDC_G1
D8	PF0	GPIO24_SDMMC3_D0
A5	PF1	GPIO23_SDMMC3_CMD
D9	PF4	GPIO25_SDMMC3_D1
B6	PD4	BT_USART2_RTS
D7	PF5	GPIO26_SDMMC3_D2
B5	PD10	LTDC_B3
D6	PE0	SAI2_MCLK_A
C8	PE1	ARDUINO_D2_GPIO
D5	PH8	LTDC_R2
C5	PH9	LTDC_R3
A4	PE11	ARDUINO_D10_SPI4_NSS/TIM1_CH2
B4	PE12	ARDUINO_D13_SPI4_SCK
A3	PE13	ARDUINO_D12_SPI4_MISO
C4	PH11	GPIO6_TIM5_CH2
C6	PE14	ARDUINO_D11_SPI4_MOSI/TIM1_CH4
D3	PE15	LTDC_R7
B3	PH4	WLAN_REG_ON_GPIO

10 Federal Communications Commission (FCC) and ISED Canada Compliance Statements

Identification of products: STM32MP157D-DK1 and STM32MP157F-DK2

Part 15.19

This device complies with Part 15 of the FCC Rules. Operation is subject to the following two conditions: (1) this device may not cause harmful interference, and (2) this device must accept any interference received, including interference that may cause undesired operation.

Part 15.21

Any changes or modifications to this equipment not expressly approved by STMicroelectronics may cause harmful interference and void the user's authority to operate this equipment.

Part 15.105

This equipment has been tested and found to comply with the limits for a Class A digital device, pursuant to part 15 of the FCC Rules. These limits are designed to provide reasonable protection against harmful interference when the equipment is operated in a commercial environment. This equipment generates, uses, and can radiate radio frequency energy and, if not installed and used in accordance with the instruction manual, may cause harmful interference to radio communications. Operation of this equipment in a residential area is likely to cause harmful interference in which case the user will be required to correct the interference at his own expense.

Note: Use only shielded cables for USB, Ethernet, HDMI® cables. Use added ferrite clamp on audio cable (one turn).

Responsible party (in the USA)

Terry Blanchard
Americas Region Legal | Group Vice President and Regional Legal Counsel, The Americas
STMicroelectronics, Inc.
750 Canyon Drive | Suite 300 | Coppel, Texas 75019
USA

ISED Canada ICES-003

CAN ICES-3 (A) / NMB-3 (A)

10.1 Additional FCC and ISED Canada Compliance Statements for STM32MP157F-DK2

Contains FCC ID: VPYLB1DX
Contains IC:772C-LB1DX

ISED Licence-Exempt Radio Apparatus

This device contains license-exempt transmitter(s)/receiver(s) that comply with Innovation, Science and Economic Development Canada's license-exempt RSS(s). Operation is subject to the following two conditions:

1. This device may not cause interference.
2. This device must accept any interference, including interference that may cause undesired operation of the device.

Appareils radio exempts de licence ISDE

L'émetteur/récepteur exempt de licence contenu dans le présent appareil est conforme aux CNR d'Innovation, Sciences et Développement économique Canada applicables aux appareils radio exempts de licence.

L'exploitation est autorisée aux deux conditions suivantes :

1. L'appareil ne doit pas produire de brouillage ;
2. L'appareil doit accepter tout brouillage radioélectrique subi, même si le brouillage est susceptible d'en compromettre le fonctionnement.

Radio Frequency (RF) Exposure Compliance of Radiocommunication Apparatus

To satisfy FCC and ISED Canada RF Exposure requirements for mobile devices, a separation distance of 20 cm or more should be maintained between the antenna of this device and persons during operation. To ensure compliance, operation at closer than this distance is not recommended. This transmitter must not be co-located or operating in conjunction with any other antenna or transmitter.

Pour satisfaire aux exigences FCC et ISDE Canada concernant l'exposition aux champs RF pour les appareils mobile, une distance de séparation de 20 cm ou plus doit être maintenu entre l'antenne de ce dispositif et les personnes pendant le fonctionnement. Pour assurer la conformité, il est déconseillé d'utiliser cet équipement à une distance inférieure. Cet émetteur ne doit pas être co-situé ou fonctionner conjointement avec une autre antenne ou un autre émetteur.

11 CE conformity

11.1 Warning

EN 55032 / CISPR32 (2012) Class A product

Warning: this device is compliant with Class A of EN55032 / CISPR32. In a residential environment, this equipment may cause radio interference.

11.2 Simplified declaration of conformity

Hereby, STMicroelectronics declares that the radio equipment types STM32MP157D-DK1 and STM32MP157F-DK2 are in compliance with Directive 2014/53/EU. The full text of the EU declaration of conformity is available on the next page.

UE Declaration of Conformity

Document Number:

We, the undersigned,

 Manufacturer or representative: *STMicroelectronics*
 Address: *190 Avenue du Coq, Rousset 13106*
 Country: *FRANCE*
 Phone number: *+33 6 76922896*
 E-mail: *JOEL.HULOUX @ ST.COM*
Designated product,

 Description: Discovery kits with STM32MP157 MPUs
 Brand name or trade mark: STMicroelectronics
 Identification / Designation: STM32MP157F-DK2, STM32MP157D-DK1
 Restrictive use: Indoor use only.
 Frequency band 1: 2400-2483.5MHz (Bluetooth, WIFI)
 Max power: 100mW e.i.r.p

Certify and declare under our sole responsibility that the designated product is in conformity with the essential requirements and provisions of the following European Directives:
 Directive **2014/53/EU** of the European Parliament and of the Council of 16 April 2014 on the harmonisation of the laws of the Member States relating to the making available on the market of **radio equipment (RED)**.
The conformity of the designated product(s) with the provisions of this European Directive is given by the compliance with the following European Standard(s):

Essential requirements of article 3.1a) of RED: (Safety, electrical)	- EN 60950-1 (2006+A11/2009+A1/2010+A12/2011+A2/2013) - EN 62368-1 (2014+A11/2017)
Essential requirements of article 3.1a) of RED: (Safety, health)	- EN 62311 (2008)
Essential requirements of article 3.1b) of RED: (Electromagnetic Compatibility)	- EN 55032 (2012) / EN 55035 (2017) - ETSI EN 301 489-1 (V2.2.3) - ETSI EN 301 489-17 (V3.1.1 + Draft V3.2.2)
Essential requirements of article 3.2) of RED: (Efficient use of radio spectrum)	- ETSI EN 300 328 (V2.1.1)

 Directive **2011/65/EU** of the European Parliament and of the Council of 8 June 2011 on the restriction of the use of certain hazardous substances (**ROHS**) in electrical and electronic equipment.

 Directive **2012/19/EU** of the European Parliament and of the Council of 4 July 2012 on waste electrical and electronic equipment (**WEEE**).

Name and position of person binding the manufacturer or his authorised representative

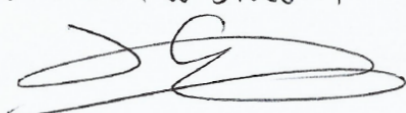
 Name: *HULOUX JOEL*
 Position: *Director, Lobbying & Standardization*
 Address: *STMicroelectronics, 2I, 190 Av du Coq Rousset France*
 Email: *Joel.Hulox @ St.com*
 Signature: 

Revision history

Table 28. Document revision history

Date	Version	Changes
10-Nov-2020	1	Initial release.

Contents

1	Features	2
2	Ordering information	3
2.1	Codification	3
3	Development environment	4
3.1	System requirements	4
3.2	Development toolchains	4
3.3	Demonstration software	4
4	Technology partners	5
5	Conventions	6
6	Delivery recommendations	7
7	Hardware layout and configuration	8
7.1	Embedded ST-LINK/V2-1	10
7.1.1	Description	10
7.1.2	Drivers	11
7.1.3	ST-LINK/V2-1 firmware upgrade	11
7.2	Power supply	11
7.2.1	5 V power supply	11
7.2.2	STPMIC1 power supply	11
7.3	Clock sources	12
7.3.1	LSE clock references	12
7.3.2	HSE clock references	12
7.4	Reset sources	12
7.5	Boot mode	12
7.5.1	Description	12
7.6	Audio.....	13
7.6.1	Description	13
7.6.2	Operating voltage	13
7.6.3	Audio codec interface	13
7.6.4	Headphone outputs.....	13

7.6.5	Audio jack connector	14
7.6.6	I/O restriction	14
7.7	USB Host	14
7.7.1	Description	14
7.7.2	USB Host interface	15
7.8	USB Type-C™ HS	16
7.8.1	Description	16
7.8.2	Operating voltage	16
7.8.3	USB HS Source	16
7.8.4	USB Type-C® connector	16
7.9	microSD™ card	17
7.9.1	Description	17
7.9.2	Operating voltage	17
7.9.3	microSD™ card interface	17
7.10	LEDs	18
7.10.1	Description	18
7.10.2	Operating voltage	19
7.10.3	LED interface	19
7.11	Buttons	19
7.11.1	Description	19
7.11.2	I/O interface	19
7.12	HDMI®	19
7.12.1	Description	19
7.12.2	HDMI® I/O interface	20
7.13	Wi-Fi® and Bluetooth® Low Energy	22
7.13.1	Description	22
7.13.2	Operating voltage	22
7.13.3	Wi-Fi® I/O interface	22
7.13.4	Bluetooth® Low Energy I/O interface	22
7.14	MIPI DSI SM LCD	23
7.14.1	Description	23

7.14.2	Operating voltage	23
7.14.3	LCD interface	24
7.15	Gigabit Ethernet	25
7.15.1	Description	25
7.15.2	Operating voltage	25
7.15.3	Ethernet interface	25
7.16	ARDUINO® connectors	27
7.16.1	Description	27
7.16.2	Operating voltage	27
7.16.3	ARDUINO® interface	27
7.17	GPIO expansion connectors	30
7.17.1	Description	30
7.17.2	GPIO expansion connector interface	30
7.18	VBAT connector	32
7.18.1	Description	32
8	STM32MP157x-DKx Discovery kits information	33
8.1	Identification	33
8.2	Product revision history	33
8.3	Known limitations	33
9	STM32MP157x-DKx I/O assignment	34
10	Federal Communications Commission (FCC) and ISED Canada Compliance Statements	38
10.1	Additional FCC and ISED Canada Compliance Statements for STM32MP157F-DK2	38
11	CE conformity	40
11.1	Warning	40
11.2	Simplified declaration of conformity	40
	Revision history	42
	Contents	43
	List of tables	46
	List of figures	47

List of tables

Table 1.	List of available products	3
Table 2.	Codification explanation	3
Table 3.	ON/OFF convention	6
Table 4.	CN11 ST-LINK USB Micro-B connector pinout	11
Table 5.	Boot mode pins	12
Table 6.	I/O configuration for the audio interface	13
Table 7.	CN10 audio jack connector pinout	14
Table 8.	I/O configuration for the USB Host interface	15
Table 9.	CN1 and CN5 USB Host connector pinout	15
Table 10.	CN7 USB Type-C [®] connector pinout	16
Table 11.	I/O configuration for the SDIO interface	17
Table 12.	CN15 microSD [™] connector pinout	18
Table 13.	I/O configuration of the LED interfaces	19
Table 14.	I/O configuration for the physical user interface	19
Table 15.	I/O configuration for the HDMI [®] interface	20
Table 16.	CN9 HDMI [®] connector pinout	21
Table 17.	I/O configuration for the Wi-Fi [®] interface	22
Table 18.	I/O configuration for the Bluetooth [®] Low Energy interface	22
Table 19.	I/O configuration of the LCD and CTP interfaces	24
Table 20.	LCD interface and CN4 connector pinout	25
Table 21.	I/O configuration of the Ethernet interface	26
Table 22.	CN8 Ethernet connector pinout	27
Table 23.	I/O configuration of the ARDUINO [®] interface	28
Table 24.	Pinout of the ARDUINO [®] connectors	29
Table 25.	GPIO connectors pinout	31
Table 26.	Product and board stickers	33
Table 27.	Discovery kit I/O assignment	34
Table 28.	Document revision history	42

List of figures

Figure 1.	STM32MP157F-DK2 top view	1
Figure 2.	STM32MP157F-DK2 bottom view	1
Figure 3.	STM32MP157x-DKx hardware block diagram	8
Figure 4.	STM32MP157x-DKx PCB layout: top side	9
Figure 5.	STM32MP157x-DKx PCB layout: bottom side	10
Figure 6.	CN11 ST-LINK USB Micro-B connector pinout	10
Figure 7.	Boot-mode switch SW1	13
Figure 8.	CN10 audio jack connector pinout	14
Figure 9.	CN1 and CN5 USB Type-A connector pinout	15
Figure 10.	CN7 USB Type-C [®] connector pinout	16
Figure 11.	microSD [™] card connector CN15	18
Figure 12.	CN9 HDMI [®] connector pinout	21
Figure 13.	LCD connection to MB1407	23
Figure 14.	CN4 LCD connector pinout	24
Figure 15.	CN8 Ethernet connector pinout	26
Figure 16.	ARDUINO [®] connectors pinout	28
Figure 17.	GPIO connectors	31
Figure 18.	CN3 VBAT connector	32

IMPORTANT NOTICE – PLEASE READ CAREFULLY

STMicroelectronics NV and its subsidiaries (“ST”) reserve the right to make changes, corrections, enhancements, modifications, and improvements to ST products and/or to this document at any time without notice. Purchasers should obtain the latest relevant information on ST products before placing orders. ST products are sold pursuant to ST’s terms and conditions of sale in place at the time of order acknowledgement.

Purchasers are solely responsible for the choice, selection, and use of ST products and ST assumes no liability for application assistance or the design of Purchasers’ products.

No license, express or implied, to any intellectual property right is granted by ST herein.

Resale of ST products with provisions different from the information set forth herein shall void any warranty granted by ST for such product.

ST and the ST logo are trademarks of ST. For additional information about ST trademarks, please refer to www.st.com/trademarks. All other product or service names are the property of their respective owners.

Information in this document supersedes and replaces information previously supplied in any prior versions of this document.

© 2020 STMicroelectronics – All rights reserved