

BLACK SPIDER

Assembly guide

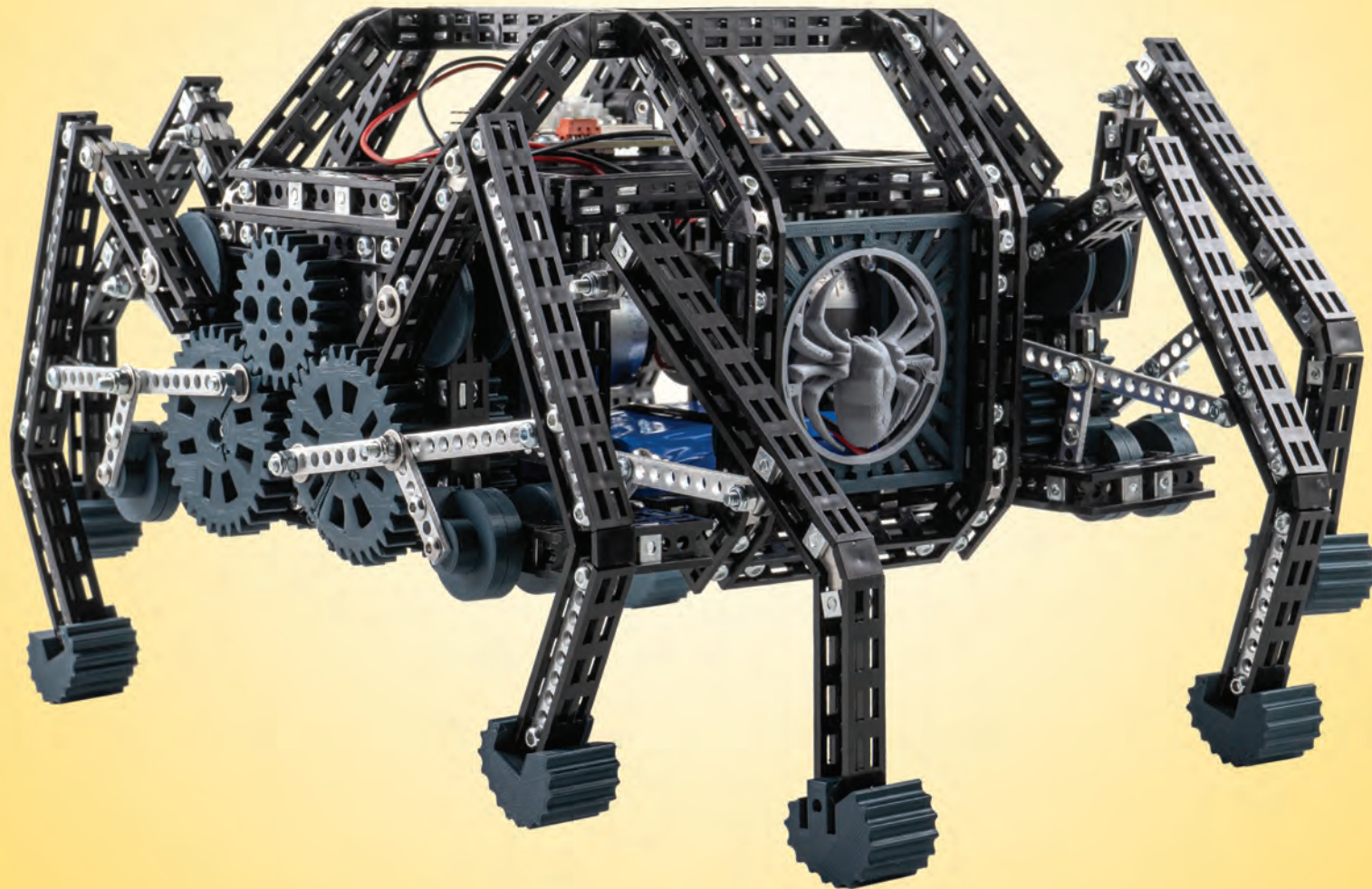

STARTING TIPS

Inserting nuts (1)

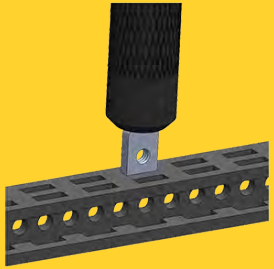

Inserting nuts (2)

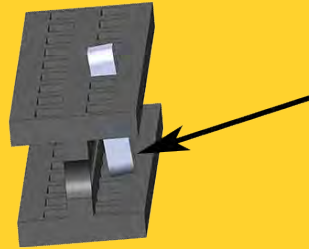

Faulty threads

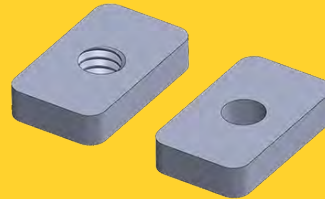

Tightening standoffs



Ruler

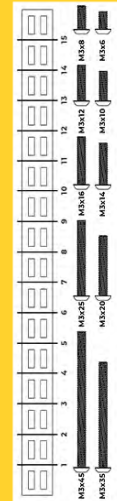

It is a good idea to start every step inserting nuts into beams (if the step requires). Use the back of the screwdriver to push in the nuts.

After entering the first slot, nuts tend to tilt. Use your thumb to push it back straight, and then again use the screwdriver to insert the nut all the way in.

Some of the nuts are missing threads. This is a manufacturing issue and we are working on it. In the mean time, we add few extra nuts. We apologize for the inconvenience.

Push Nylon Standoff with your thumb while tightening it with the wrench.

Use Beam/Bolt ruler to determine the length of beams and bolts.

For more tips, please visit the link below:

<https://totemaker.net/blog/totem-mechanics-for-beginners/>

PART LIST

<p>224x</p>  <p>M3x6 mm Bolt</p>	<p>6x</p>  <p>M3x25 mm Bolt</p>	<p>16x</p>  <p>Washer 8/1 mm M3 Nylon</p>	<p>6x</p>  <p>L-Twisted Bracket</p>	<p>4x</p>  <p>Spider foot A</p>	<p>2x</p>  <p>Upper Gear Hub</p>	<p>2x</p>  <p>Lower Gear A</p>
<p>92x</p>  <p>M3x8 mm Bolt</p>	<p>8x</p>  <p>M3x45 mm Bolt</p>	<p>24x</p>  <p>Washer 9/0.8mm M3</p>	<p>4x</p>  <p>3-Hole Bracket</p>	<p>4x</p>  <p>Spider foot B</p>	<p>4x</p>  <p>Lower Gear Hub</p>	<p>2x</p>  <p>Lower Gear B</p>
<p>8x</p>  <p>M3x10 mm Bolt</p>	<p>40x</p>  <p>Lock Nut M3</p>	<p>80x</p>  <p>2-Hole Simple Bracket</p>	<p>4x</p>  <p>3-Hole 45 Bracket</p>	<p>8x</p>  <p>Rocker</p>	<p>2x</p>  <p>Upper Gear A</p>	<p>2x</p>  <p>Lower Gear C</p>
<p>16x</p>  <p>M3x12 mm Bolt</p>	<p>226x</p>  <p>Nut M3 6x10</p>	<p>8x</p>  <p>2-Hole 45 Simple Bracket</p>	<p>2x</p>  <p>Swan 90x45</p>	<p>8x</p>  <p>Rocker Washer</p>	<p>2x</p>  <p>Upper Gear B</p>	<p>2x</p>  <p>Lower Gear D</p>
<p>8x</p>  <p>M3-HEXH 12 mm Bolt</p>	<p>64x</p>  <p>Nut M3 6x6</p>	<p>16x</p>  <p>C-Bracket</p>	<p>16x</p>  <p>Double Side Filler</p>	<p>16x</p>  <p>Upper Arm Washer</p>	<p>2x</p>  <p>Motor-Plate 37 mm</p>	
<p>8x</p>  <p>M3x14 mm Bolt</p>	<p>1x</p>  <p>Metal Nut M3</p>	<p>16x</p>  <p>2-Hole 45 Bracket</p>	<p>8x</p>  <p>Single Side Filler</p>	<p>4x</p>  <p>Nylon Standoff M3x8 mm</p>		
<p>8x</p>  <p>M3x16 mm Bolt</p>		<p>6x</p>  <p>L-Twisted Mirror Bracket</p>	<p>32x</p>  <p>Beam Plug</p>	<p>6x</p>  <p>Bearing 8x16x5</p>		

PART LIST

BEAMS:



2 cm	4 x
3 cm	4 x
4 cm	4 x
5 cm	24 x
6 cm	18 x
7 cm	6 x
9 cm	16 x
10 cm	2 x
11 cm	2 x
13 cm	2 x
17 cm	4 x

2x



Motor Coupler 6 mm

1x



RoboBoard X4

2x



Zip Tie 25 mm

2x

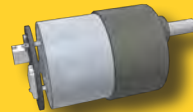

DC Motor 37 mm

1x

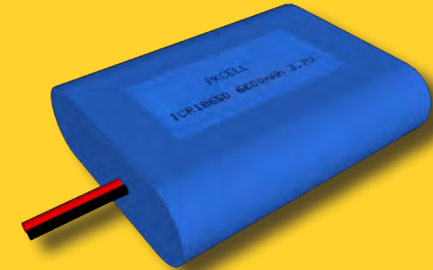

3x18650 Li-ion pack

STRIP BRACKETS:



3 cm/6H	8 x
3.5 cm/7H	12 x
4.5 cm/9H	8 x
7.5 cm/15H	8 x
9.5 cm/19H	8 x



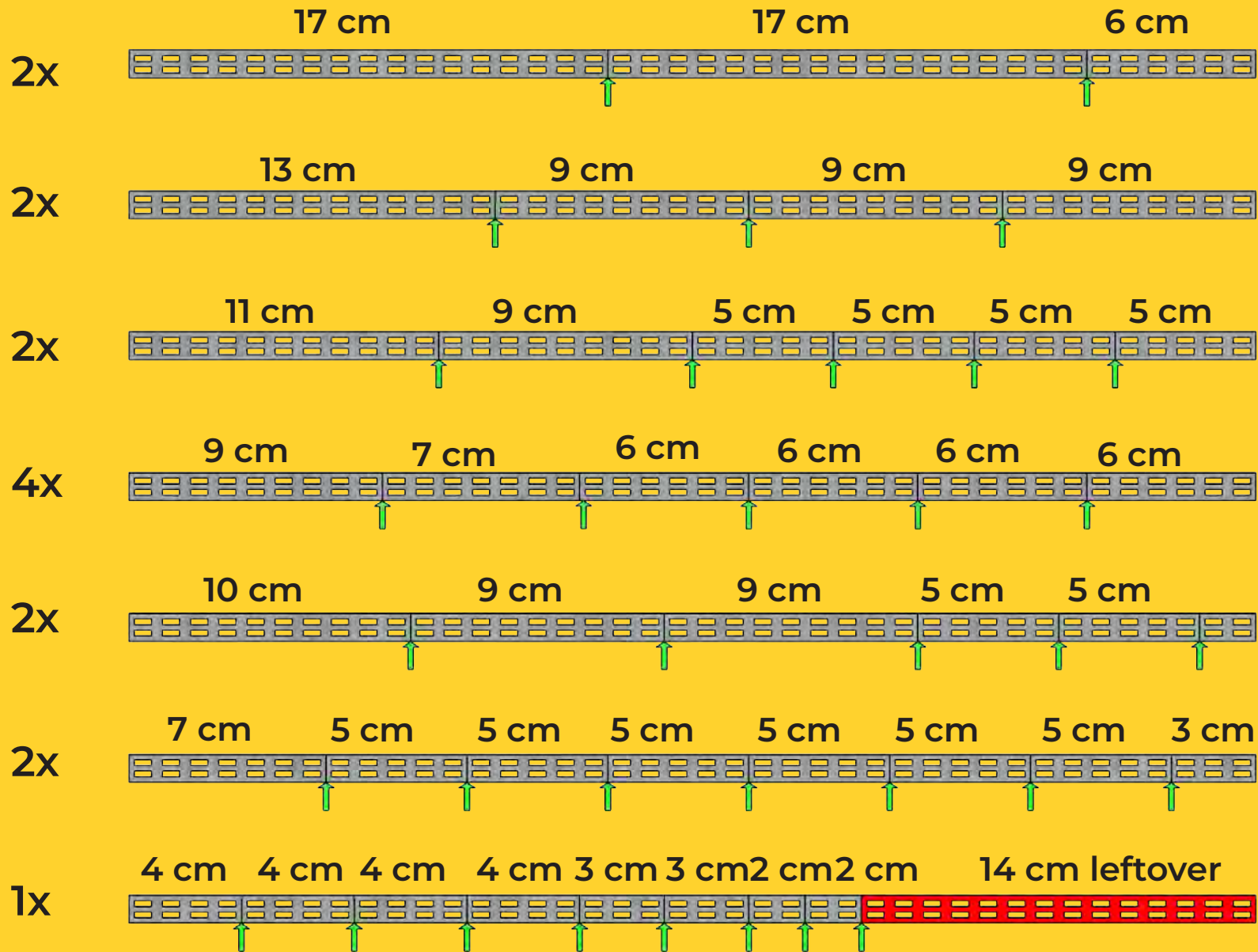

Cutting 40 cm Beams

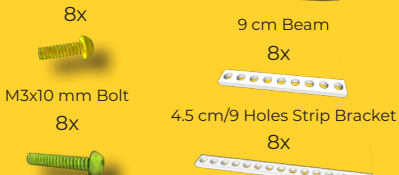
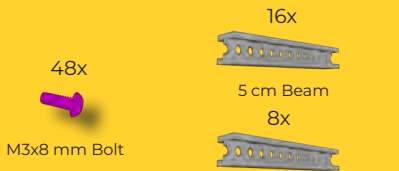
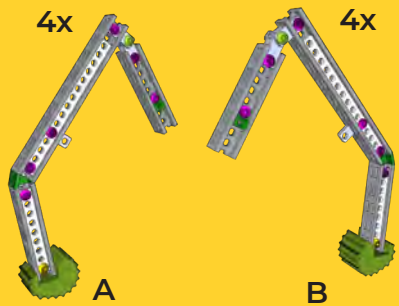

= 15x40 cm Beams Total

PART 1



- 8x

Nut M3 6x6
- 8x

M3x8 mm Bolt
- 12x

2-Hole Simple Bracket
- 4x

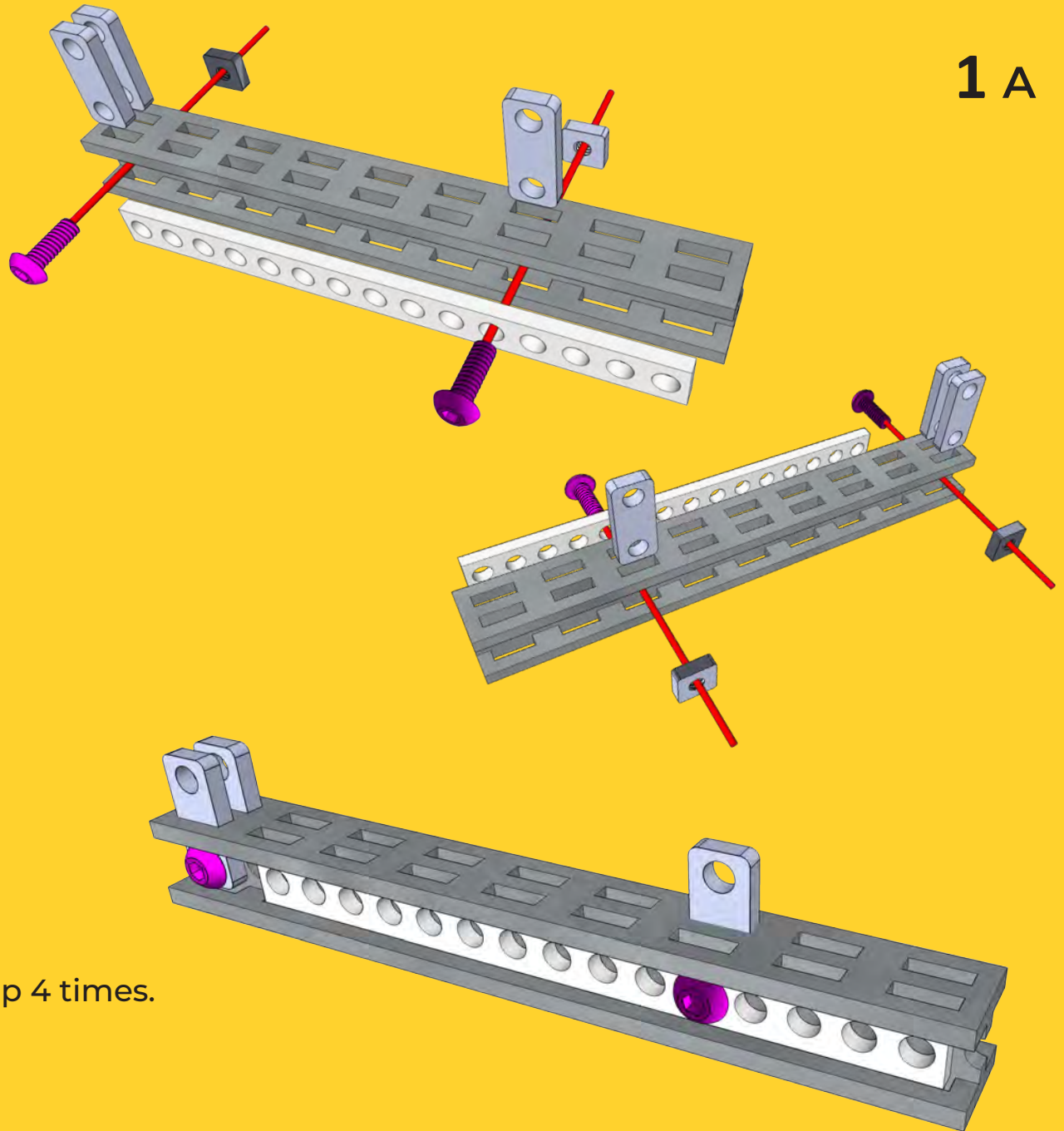
7.5 cm/15 Holes Strip Bracket
- 4x

9 cm Beam

Repeat this step 4 times.

4x

1 A



2 A

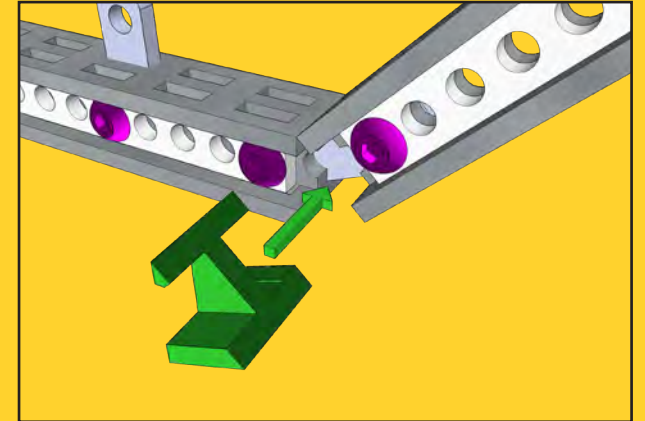
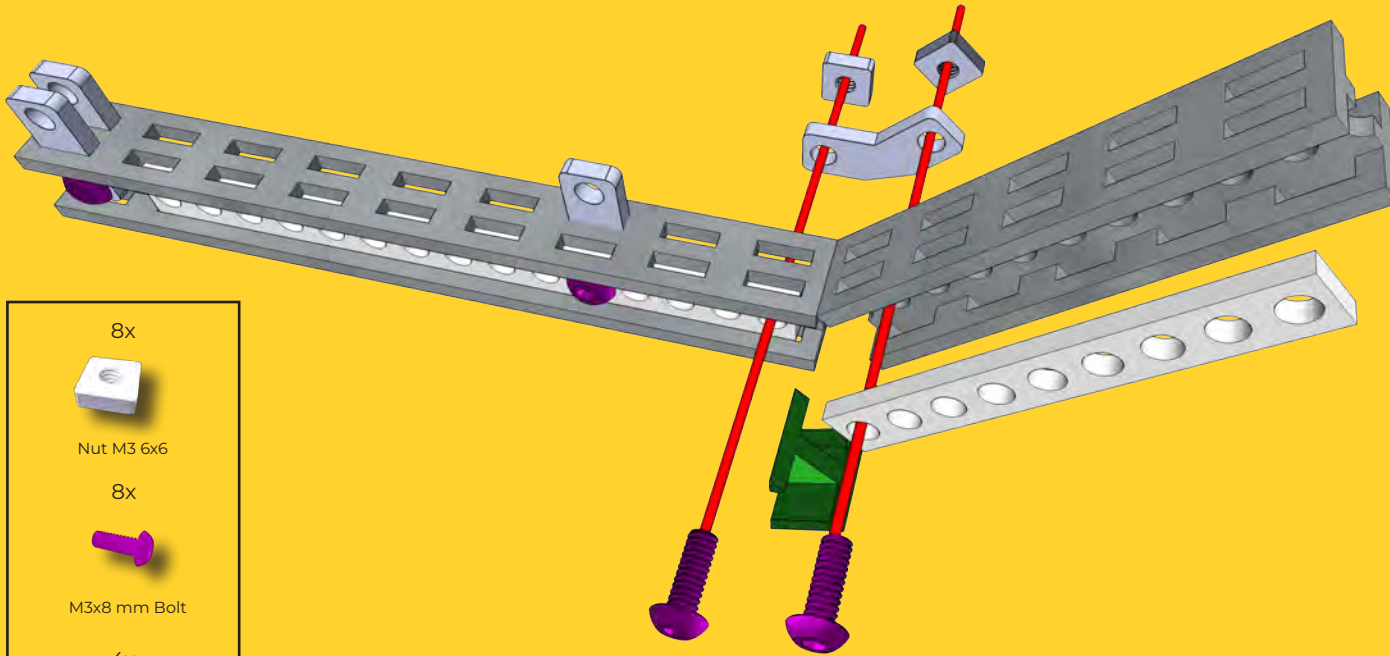

- 8x

Nut M3 6x6
- 8x

M3x8 mm Bolt
- 4x

Single Side Filler
- 4x

2-Hole 45 Simple Bracket
- 4x

5 cm Beam
- 4x



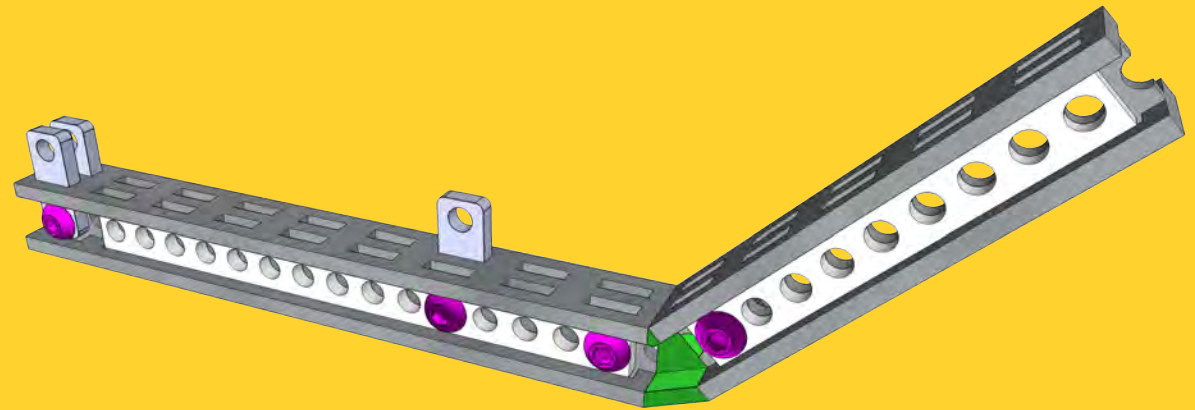

4.5 cm/9 Holes Strip Bracket



Repeat this step 4 times.

4x

3 A

- 8x

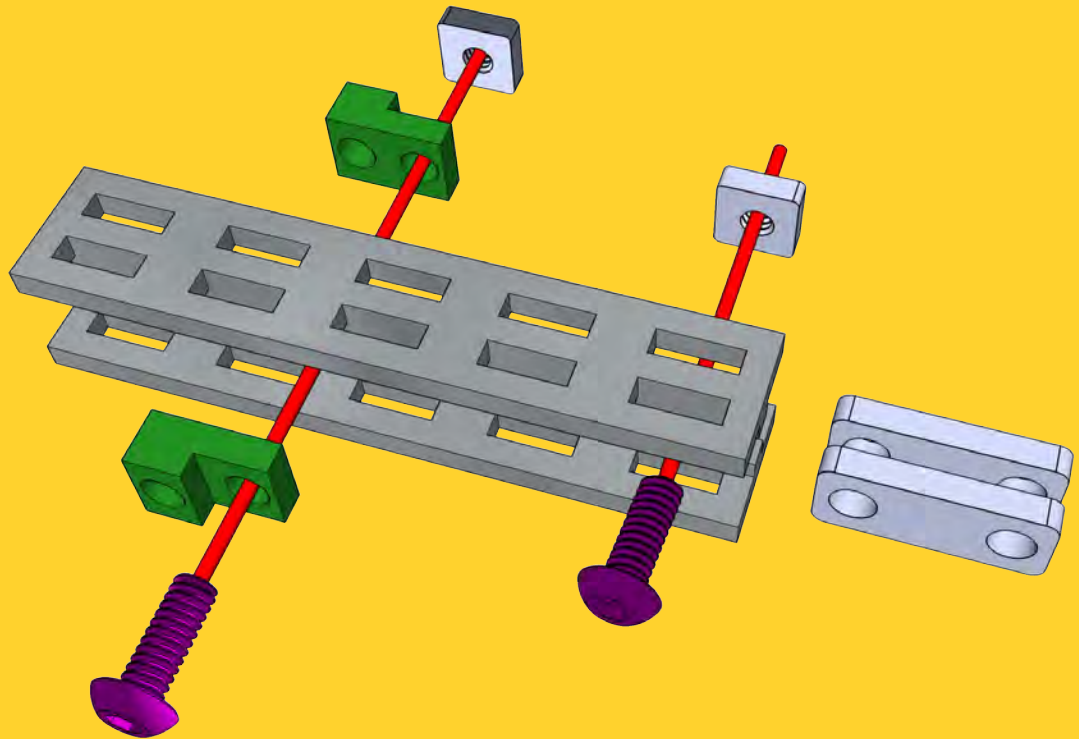
M3x8 mm Bolt
- 8x

Nut M3 6x6
- 8x

2-Hole Simple Bracket
- 8x

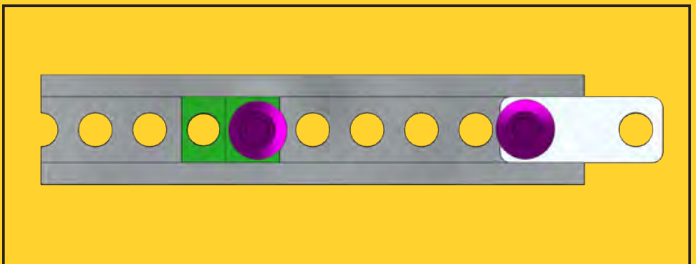
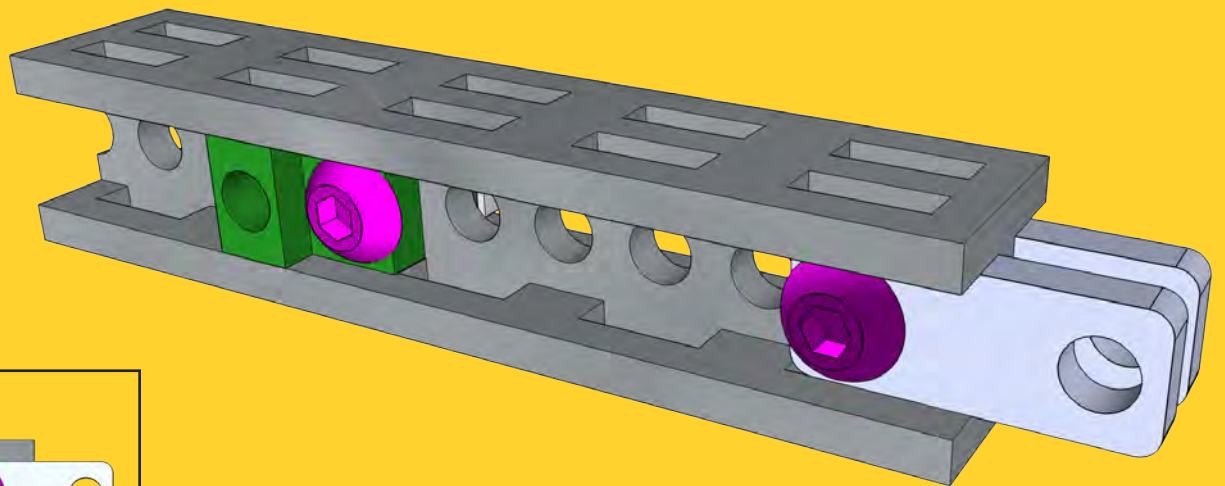
Beam Plug
- 4x

5 cm Beam



Repeat this step 4 times.

4x



4 A

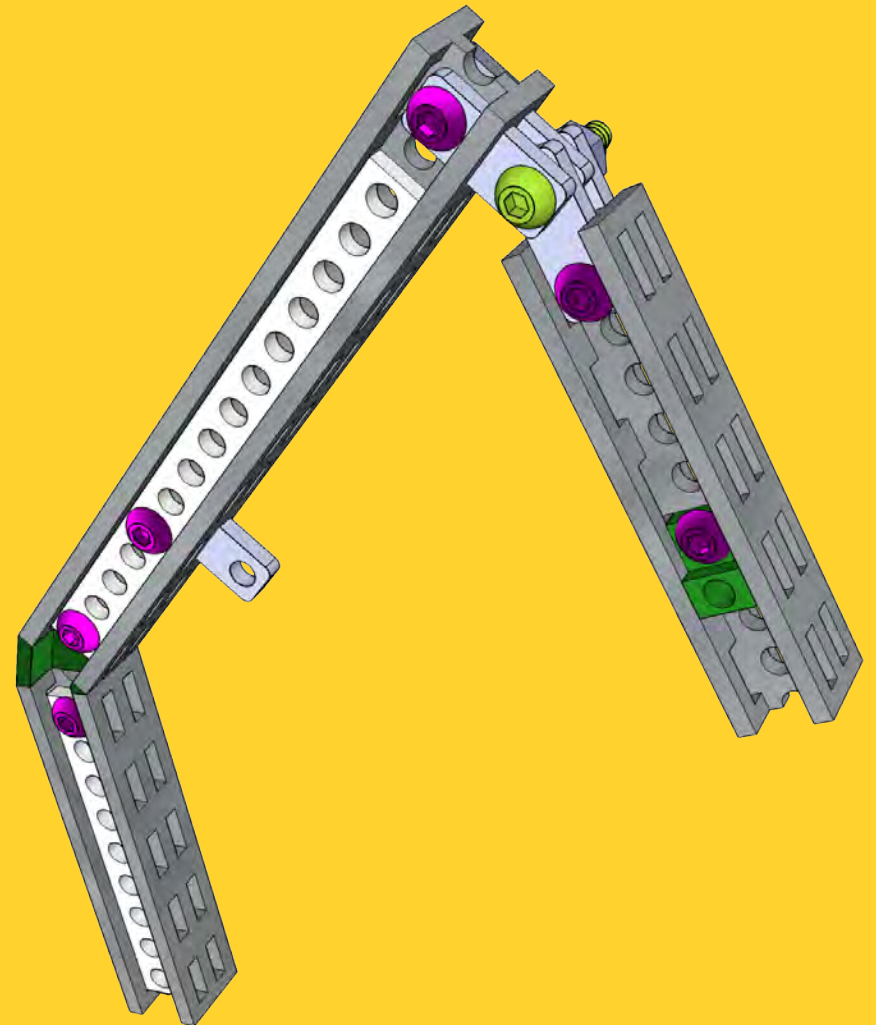
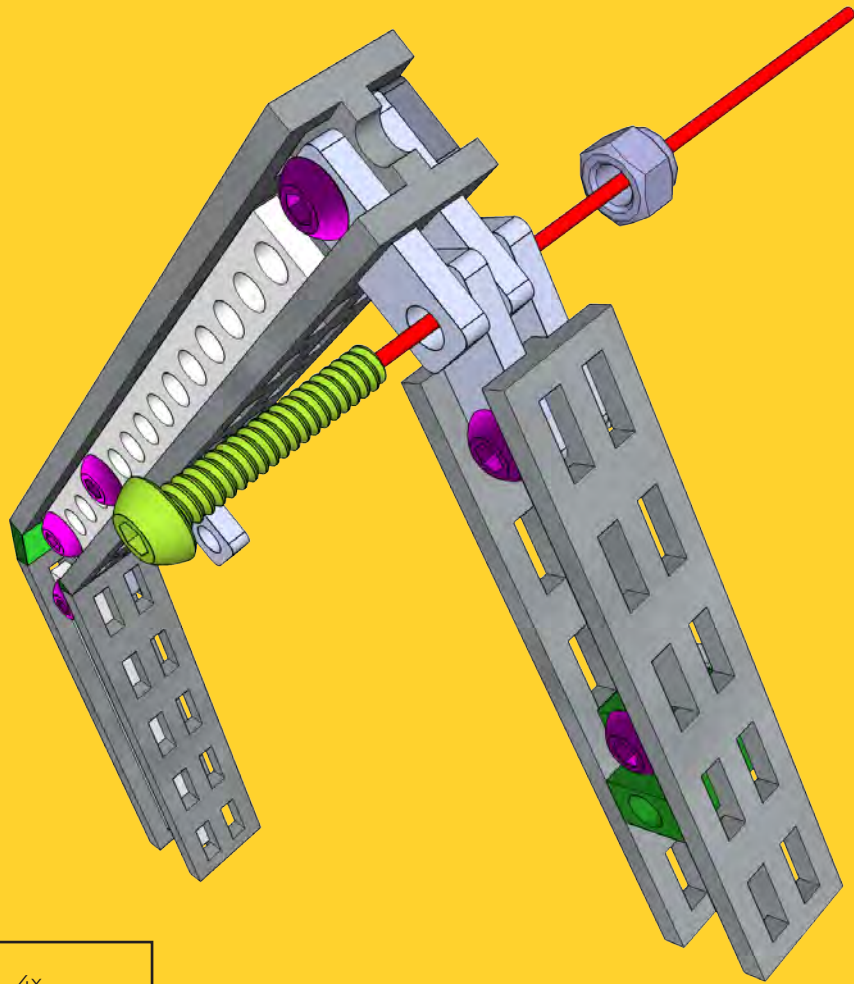

4x



M3x16 mm Bolt

4x



Lock Nut M3

Repeat this step 4 times.

4x

5 A

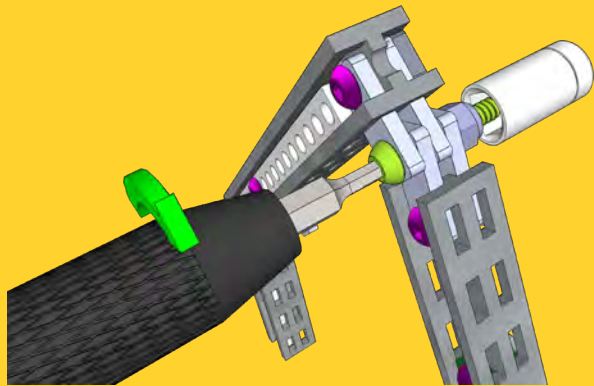
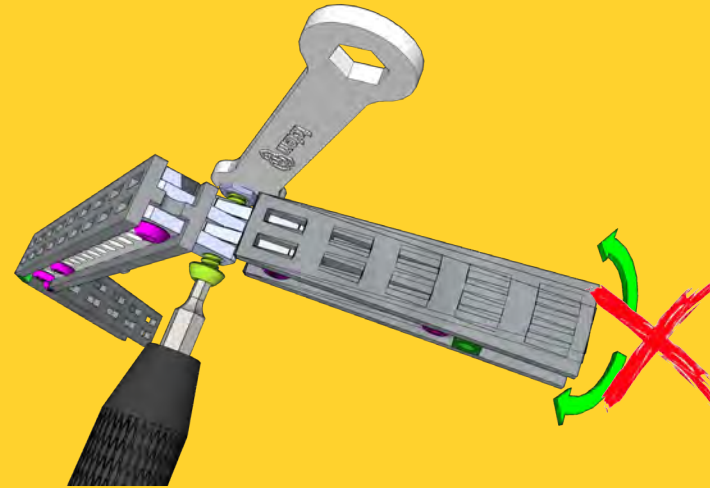
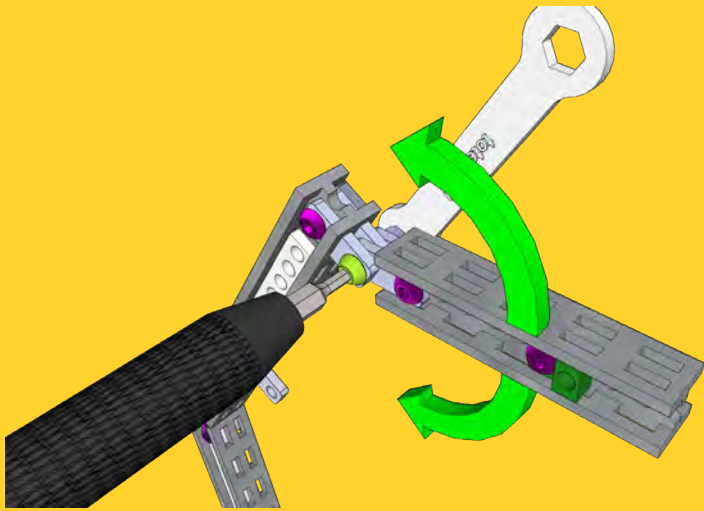

Alternatively use a socket for 5.5 mm HEX heads to hold the lock nuts.

Repeat this step 4 times.

4x

Tip for tightening lock nuts:

Here a bolt and a lock nut is used as a hub or bearing in joints between the spider leg parts. They should not be tightened too much, since they must rotate easily. But they should not be wobbly either. Find the tightening that you feel is good.

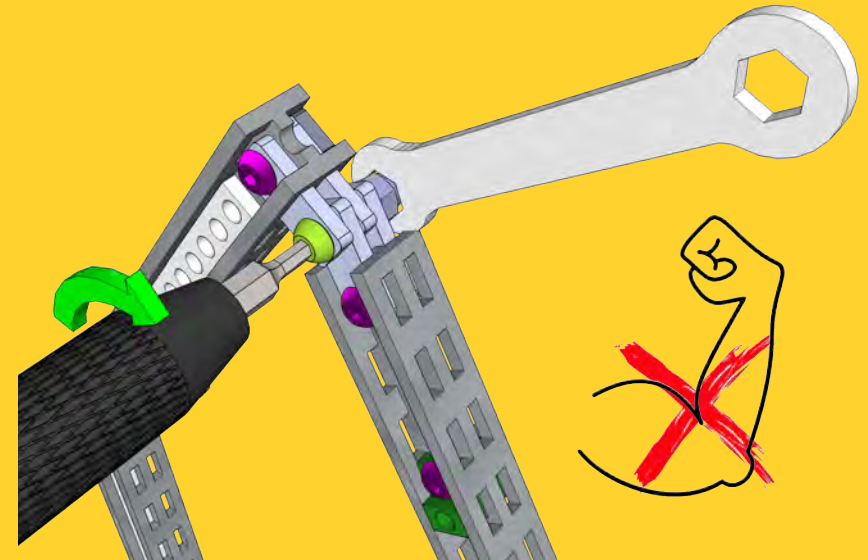

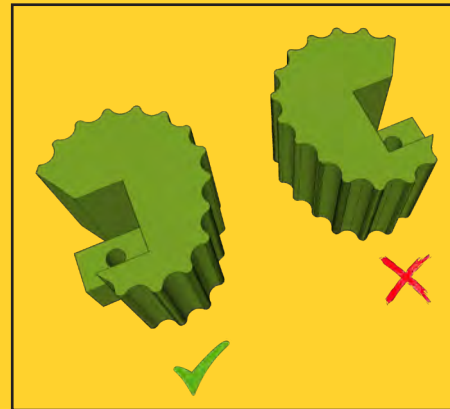
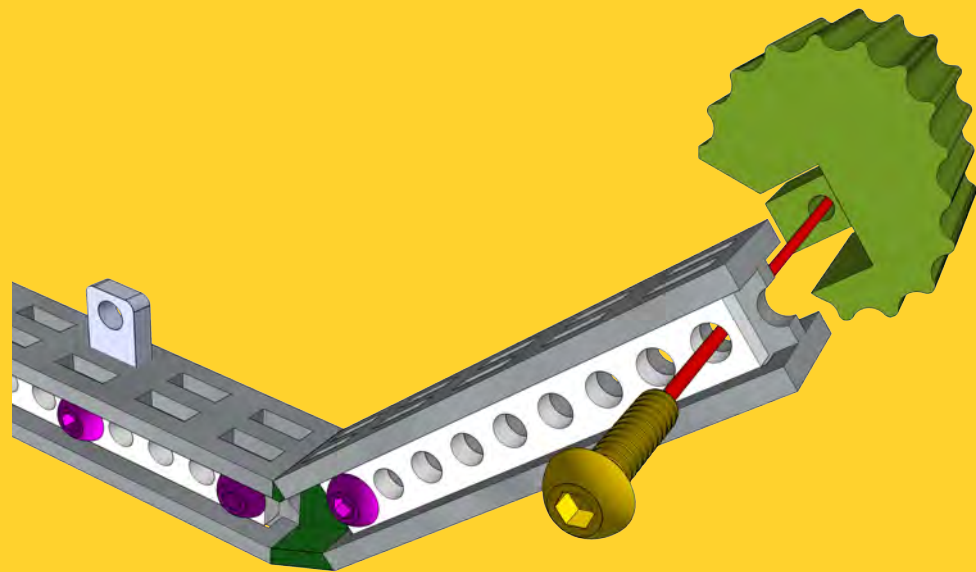

6 A

Repeat this step 4 times.

4x

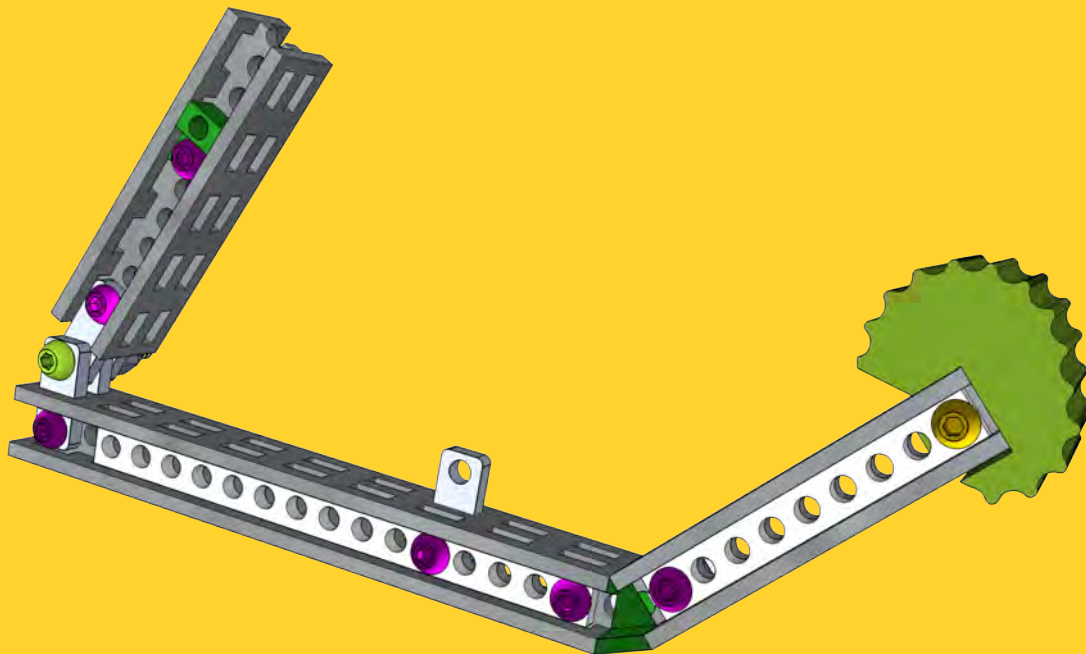



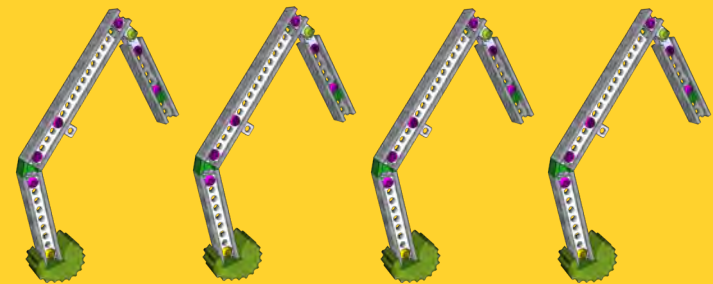



PART 1A

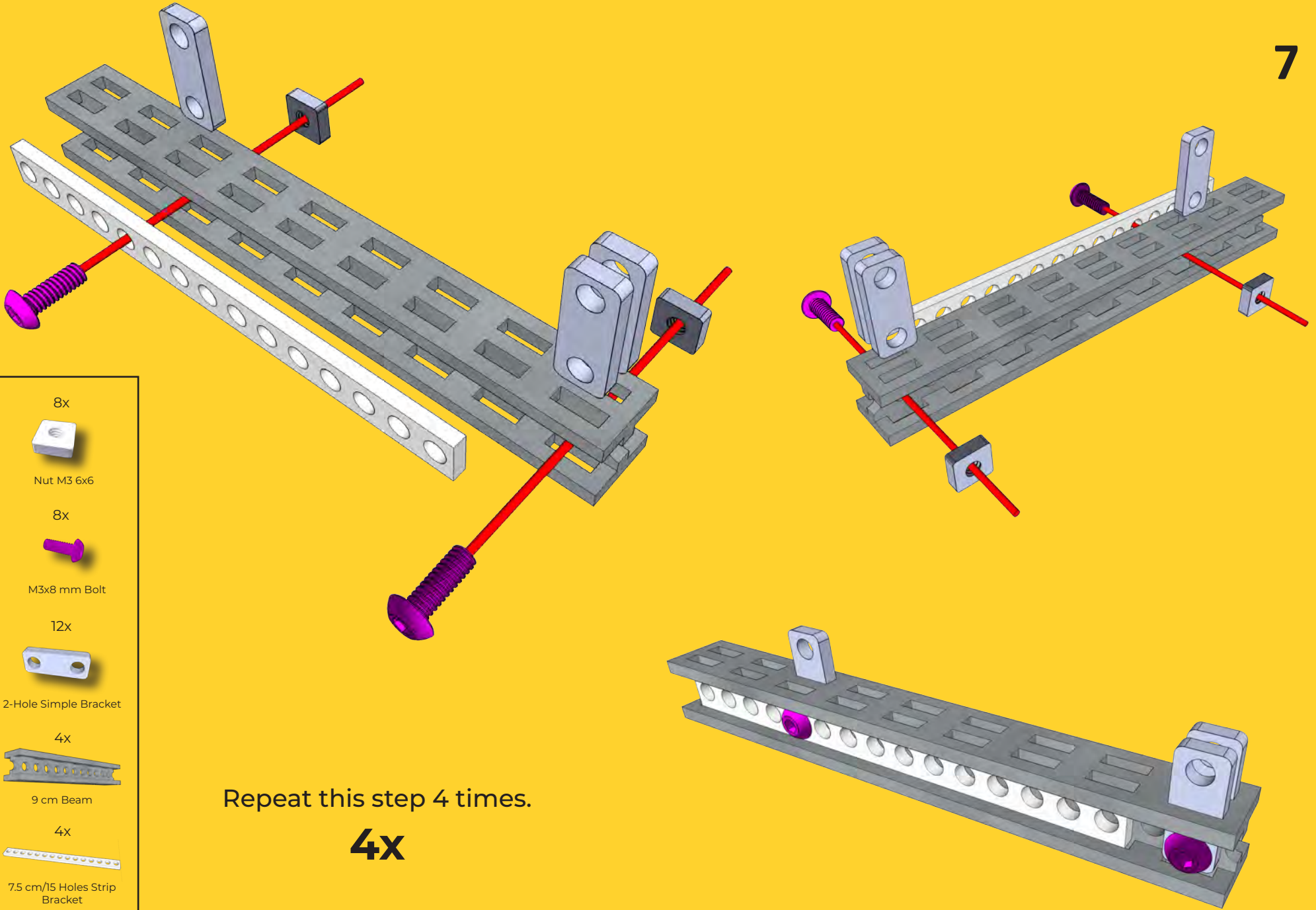

4x ✓

7 B



- 8x

Nut M3 6x6
- 8x

M3x8 mm Bolt
- 12x

2-Hole Simple Bracket
- 4x

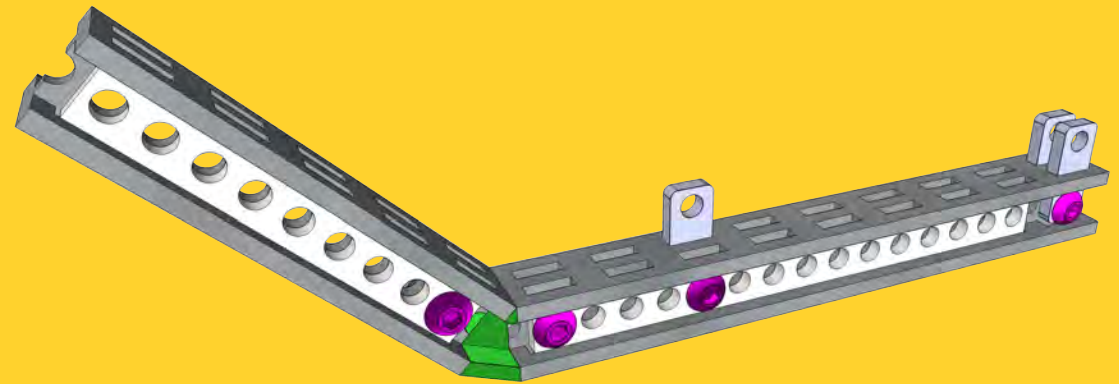
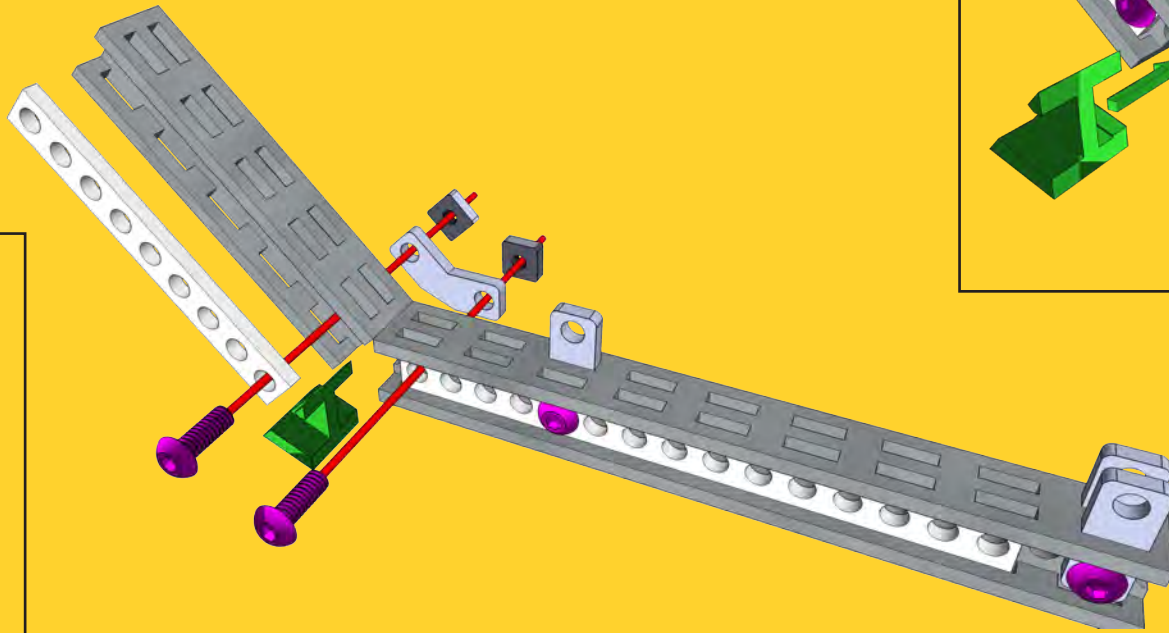
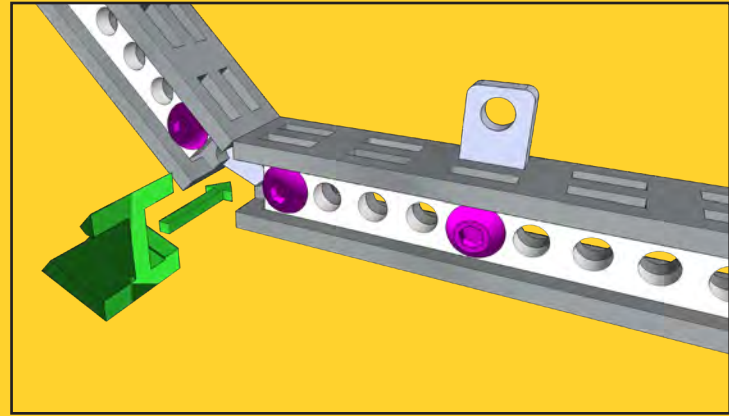
9 cm Beam
- 4x

7.5 cm/15 Holes Strip Bracket

Repeat this step 4 times.

4x

8 B



- 8x

Nut M3 6x6
- 8x

M3x8 mm Bolt
- 4x

Single Side Filler
- 4x

2-Hole 45 Simple Bracket
- 4x





5 cm Beam
- 4x

4.5 cm/9 Holes Strip Bracket

Repeat this step 4 times.

4X

9 B

- 8x

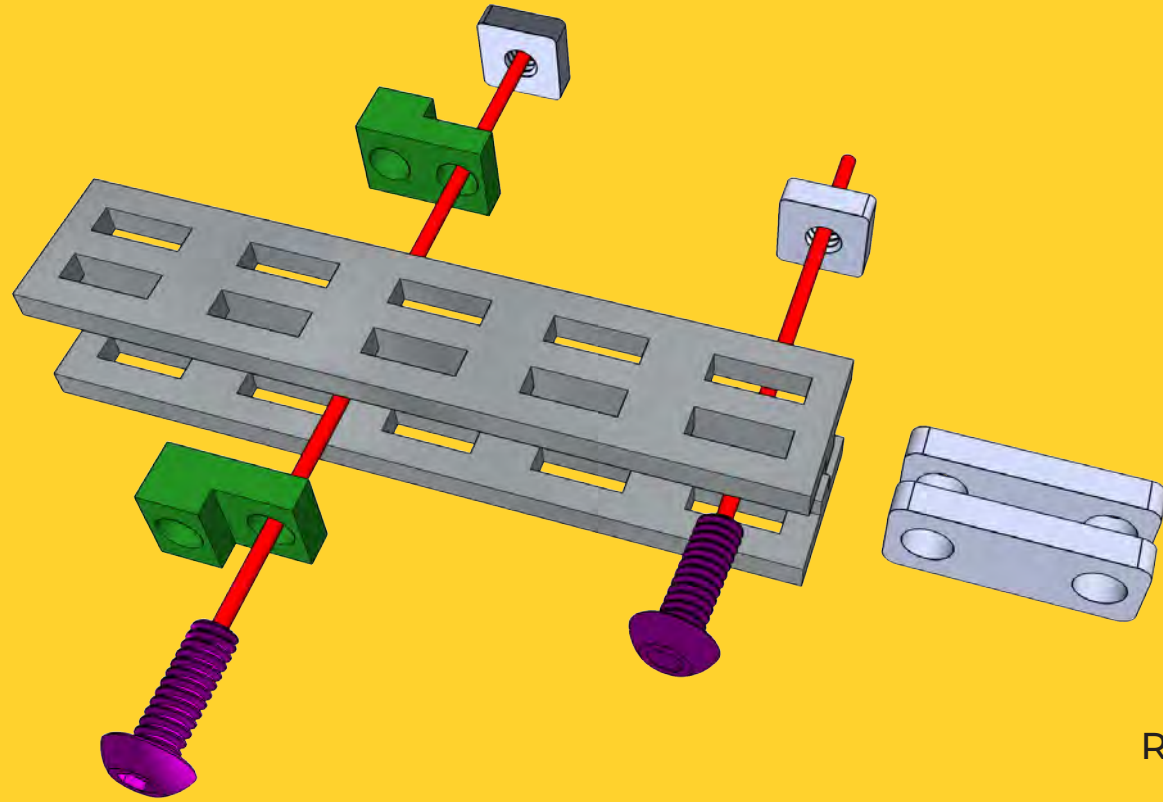
M3x8 mm Bolt
- 8x

Nut M3 6x6
- 8x

2-Hole Simple Bracket
- 8x

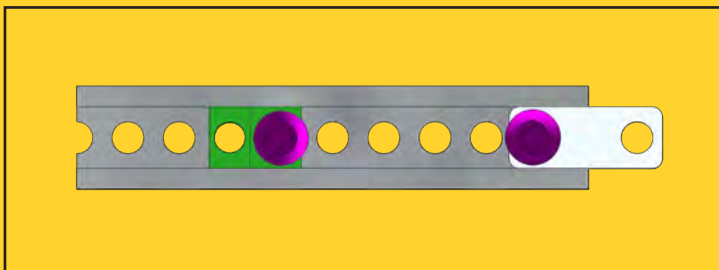
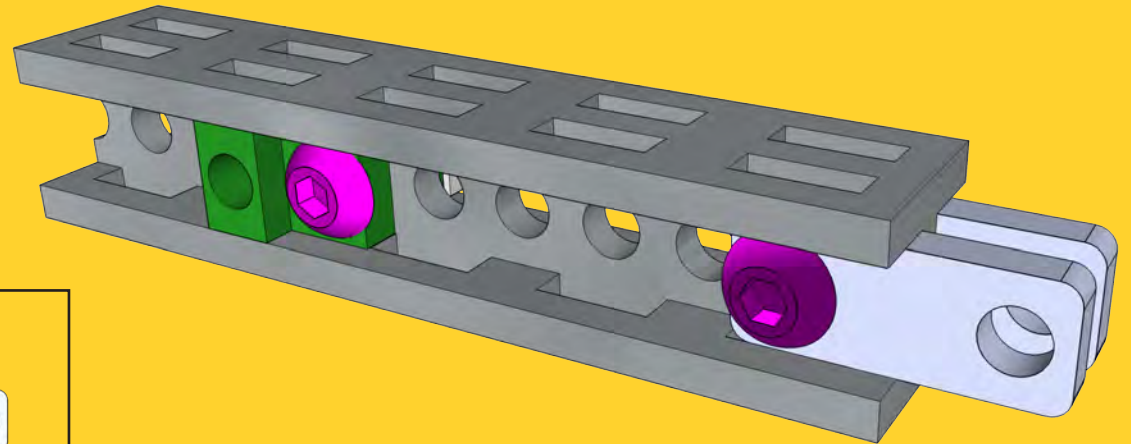
Beam Plug
- 4x

5 cm Beam



Repeat this step 4 times.

4x



10B

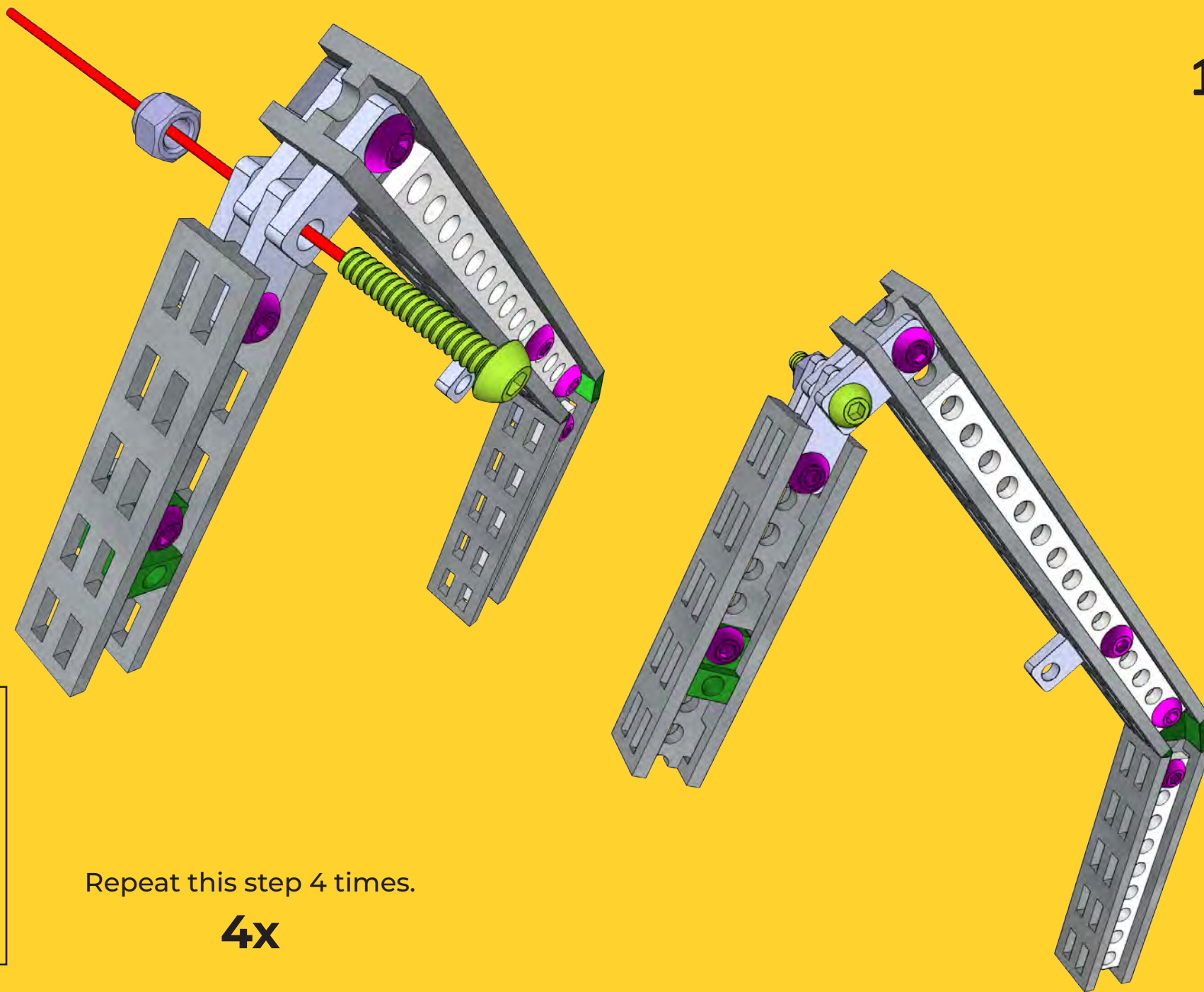

4x



M3x16 mm Bolt

4x



Lock Nut M3

Repeat this step 4 times.

4x

11B

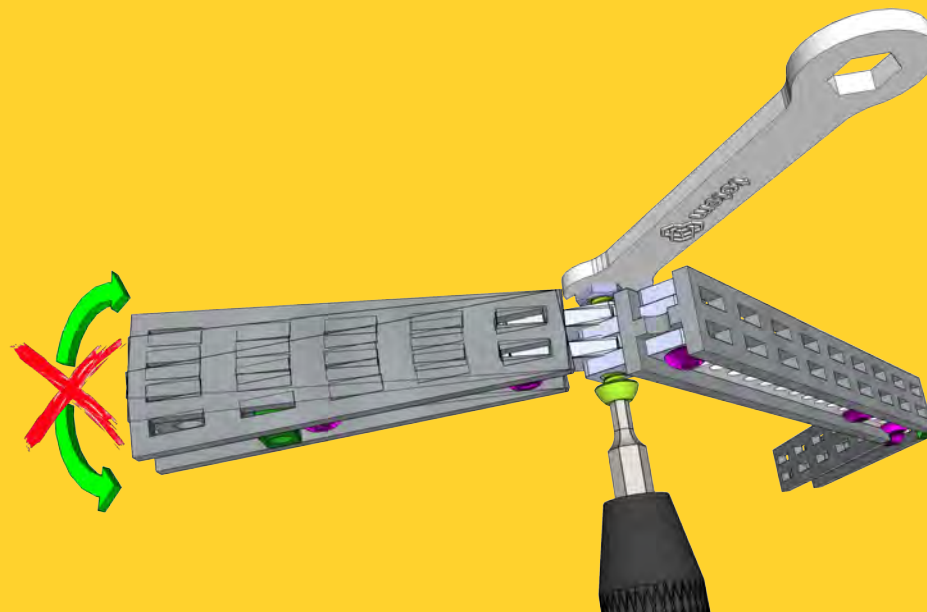
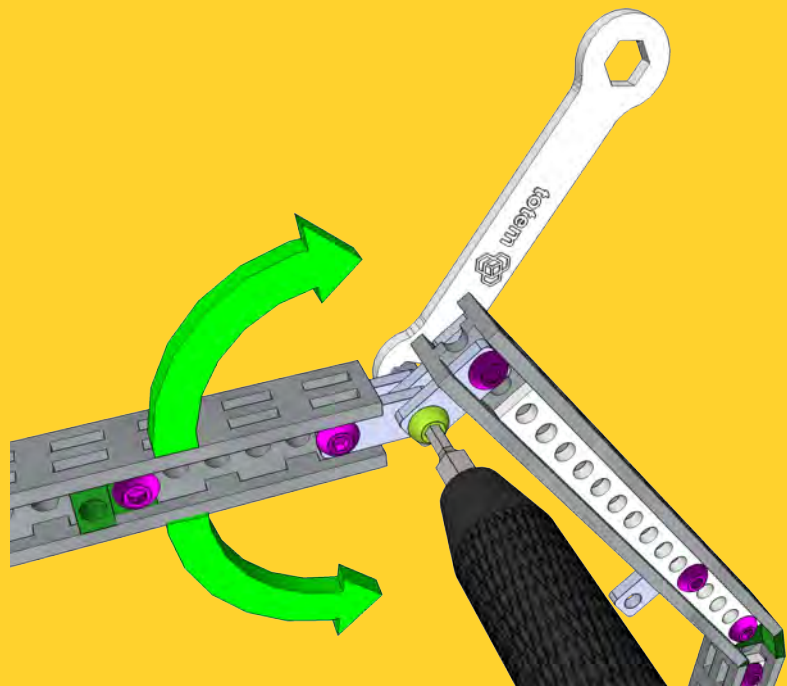

Alternatively use a socket for 5.5 mm HEX heads to hold the lock nuts.

Do not over-tighten the lock nuts.

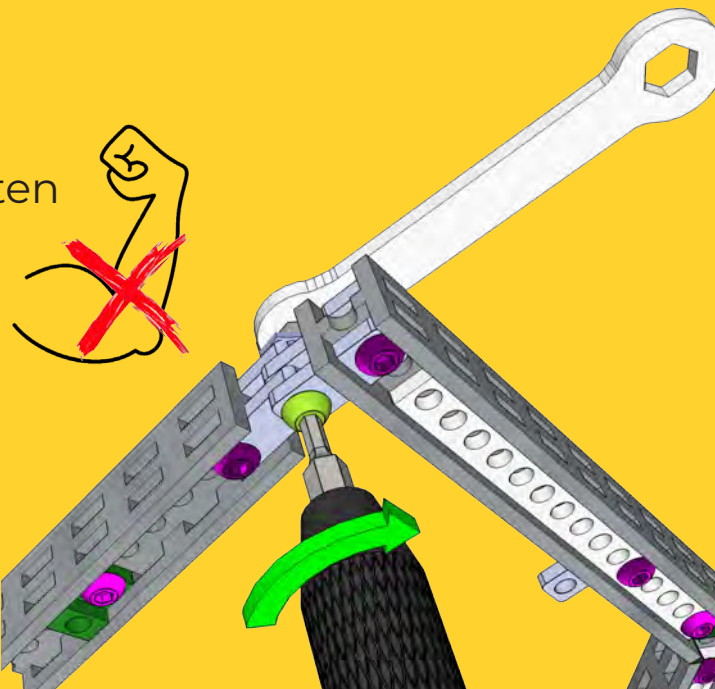

Repeat this step 4 times.

4X

12B

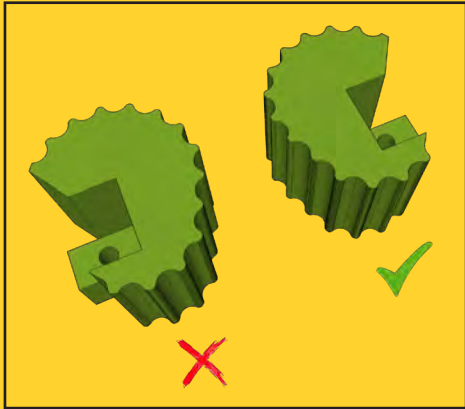
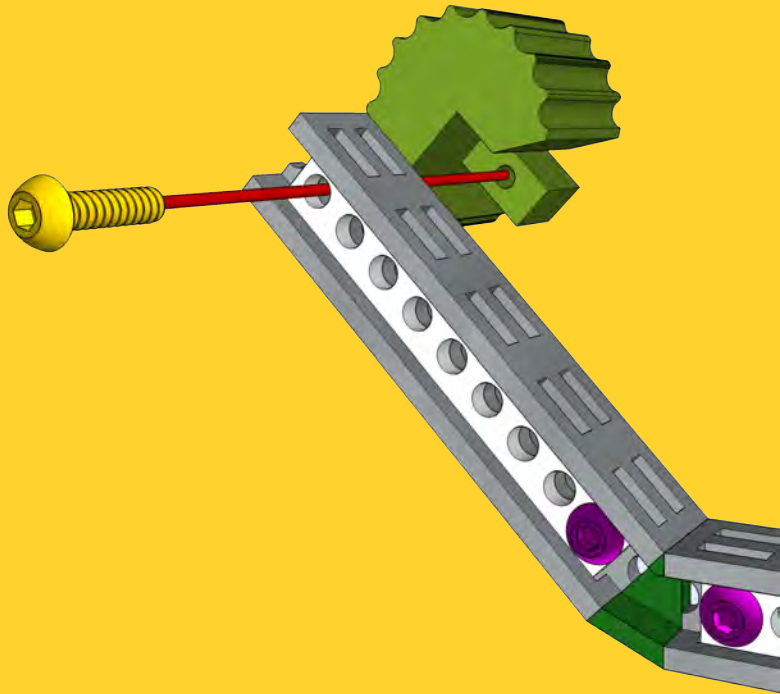

Repeat this step 4 times.

4x

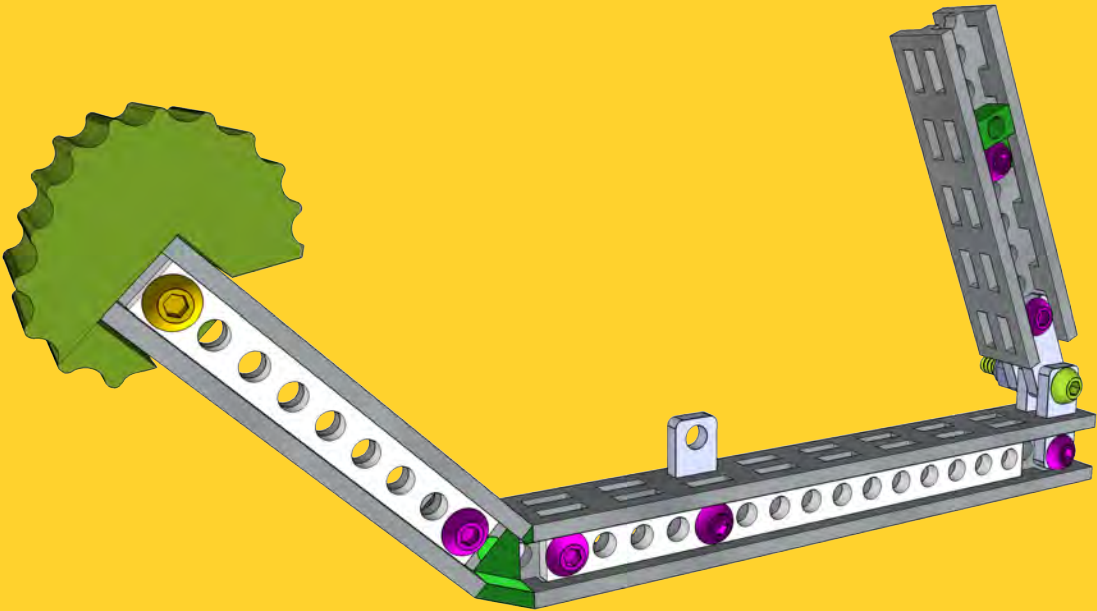

PART 1B

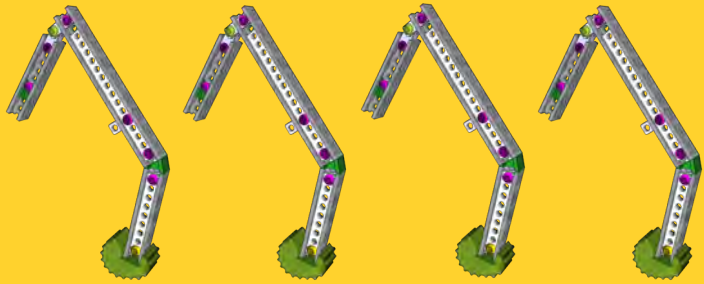

4x ✓

PART 2

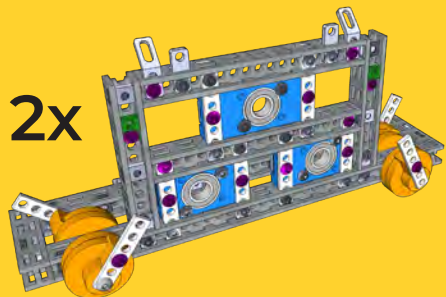

2x

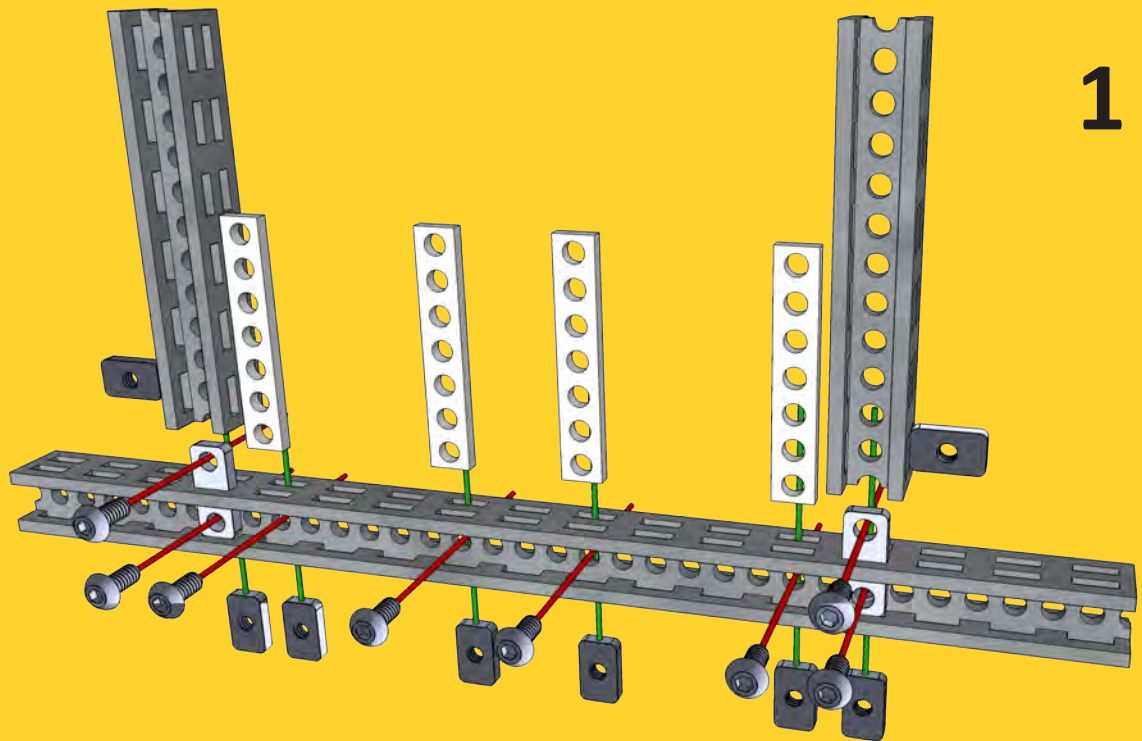
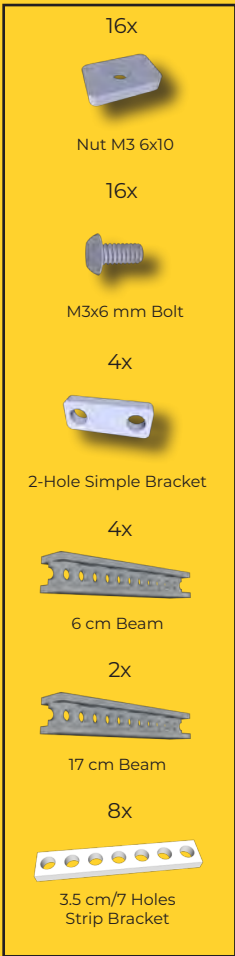
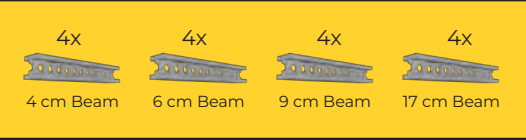
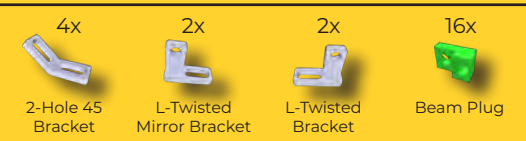
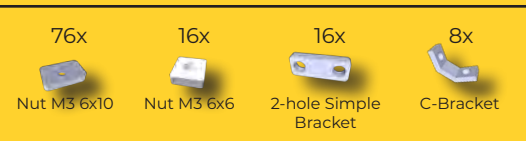
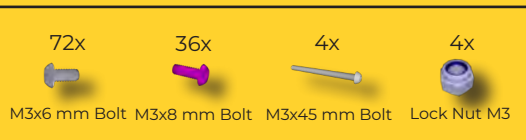

1

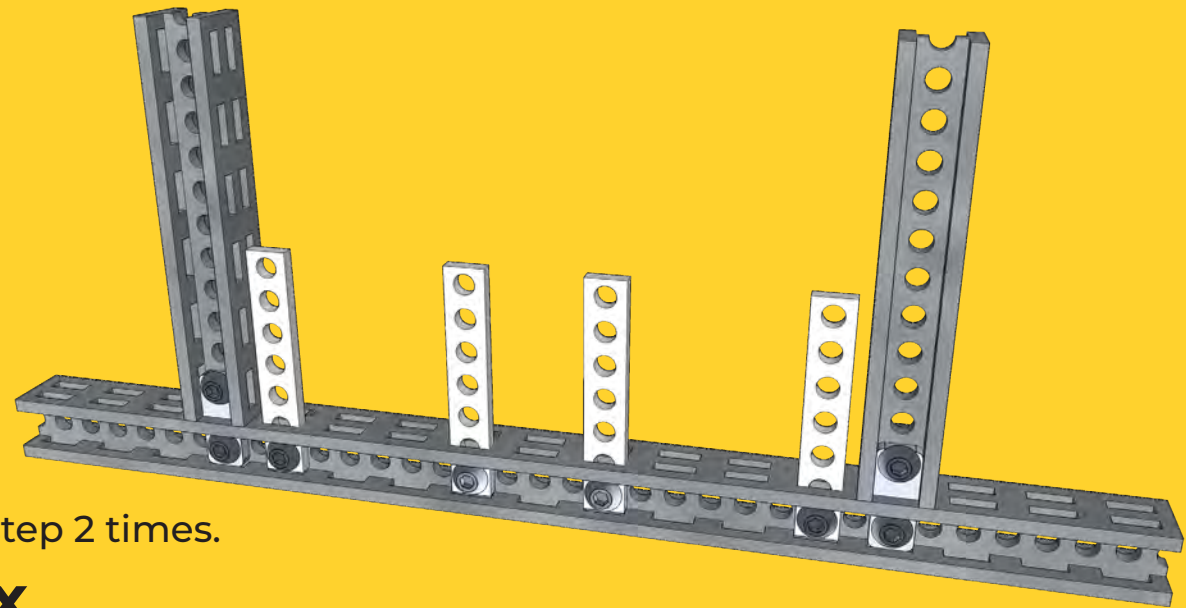



Repeat this step 2 times.

2x

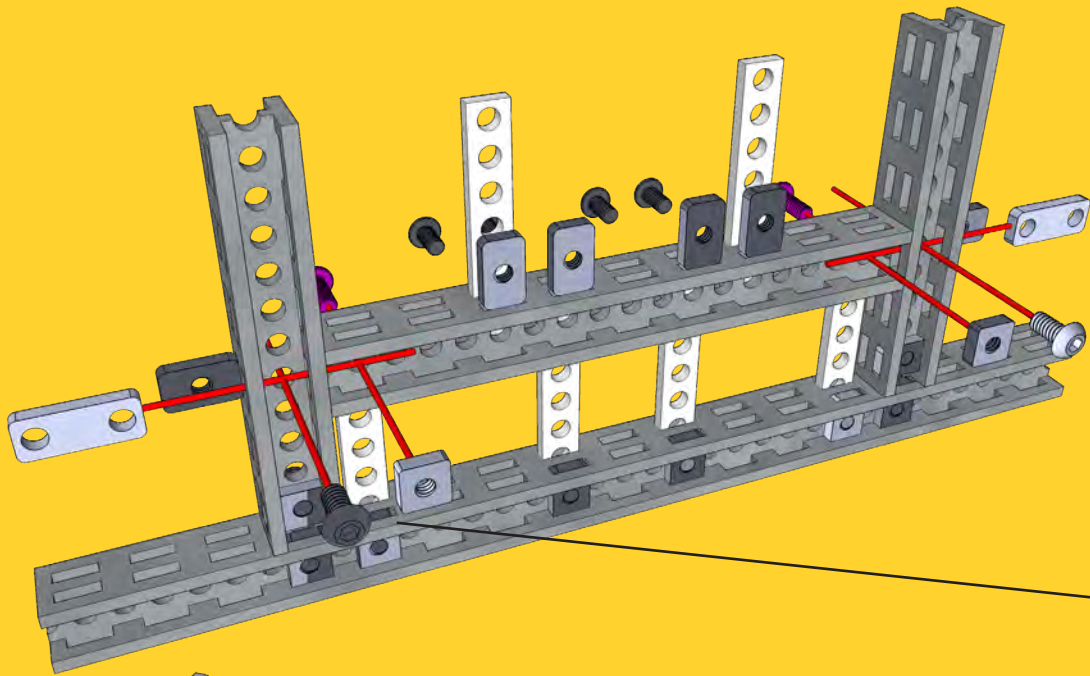
2



12x

M3x6 mm Bolt

4x

2-Hole Simple Bracket

4x

3.5 cm/7 Holes
Strip Bracket

4x

M3x8 mm Bolt

12x

Nut M3 6x10

4x

Nut M3 6x6

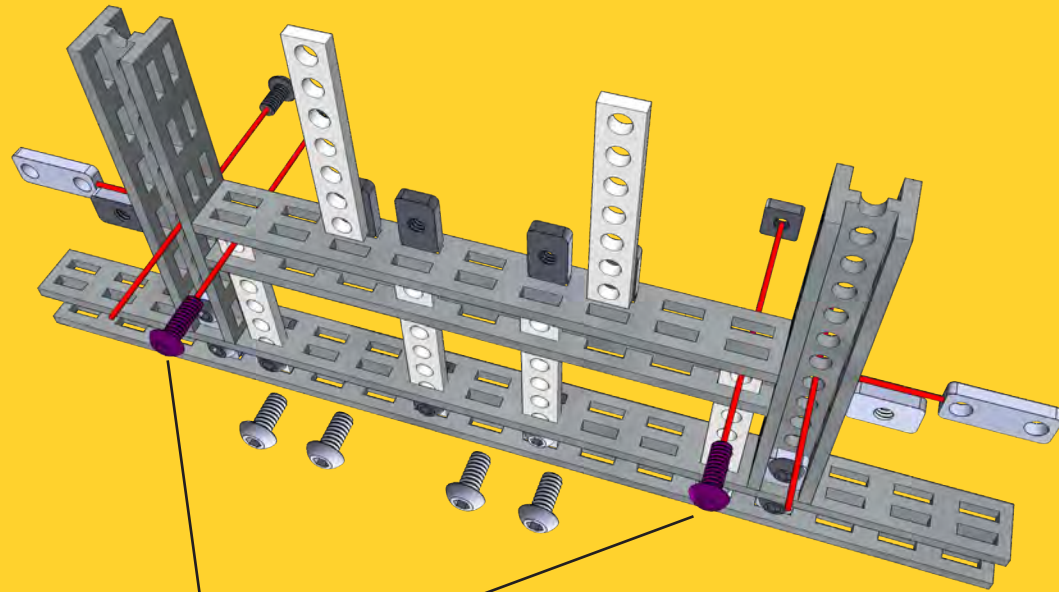
2x

9 cm Beam

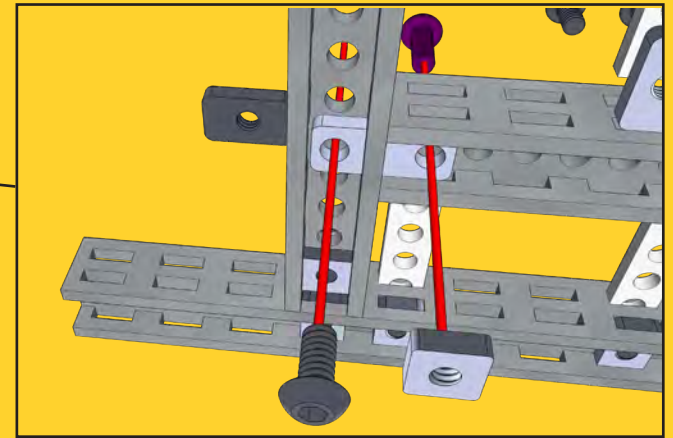

8 mm







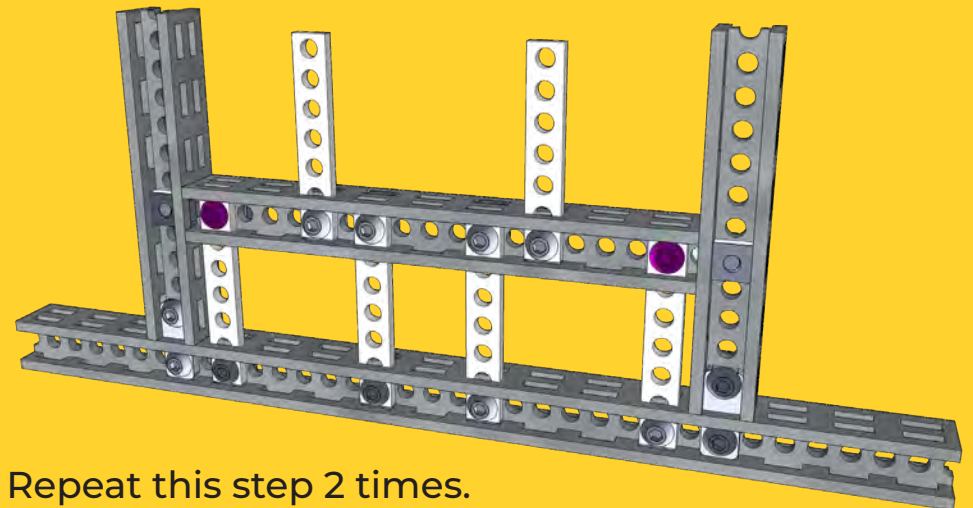

Repeat this step 2 times.

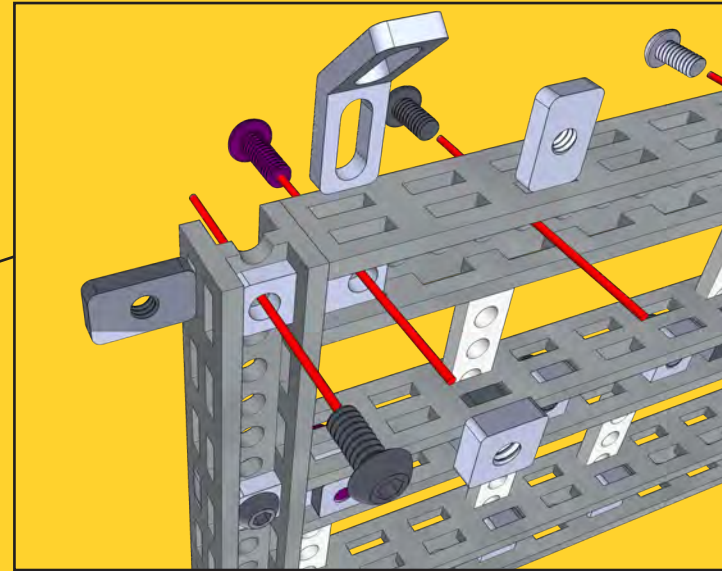
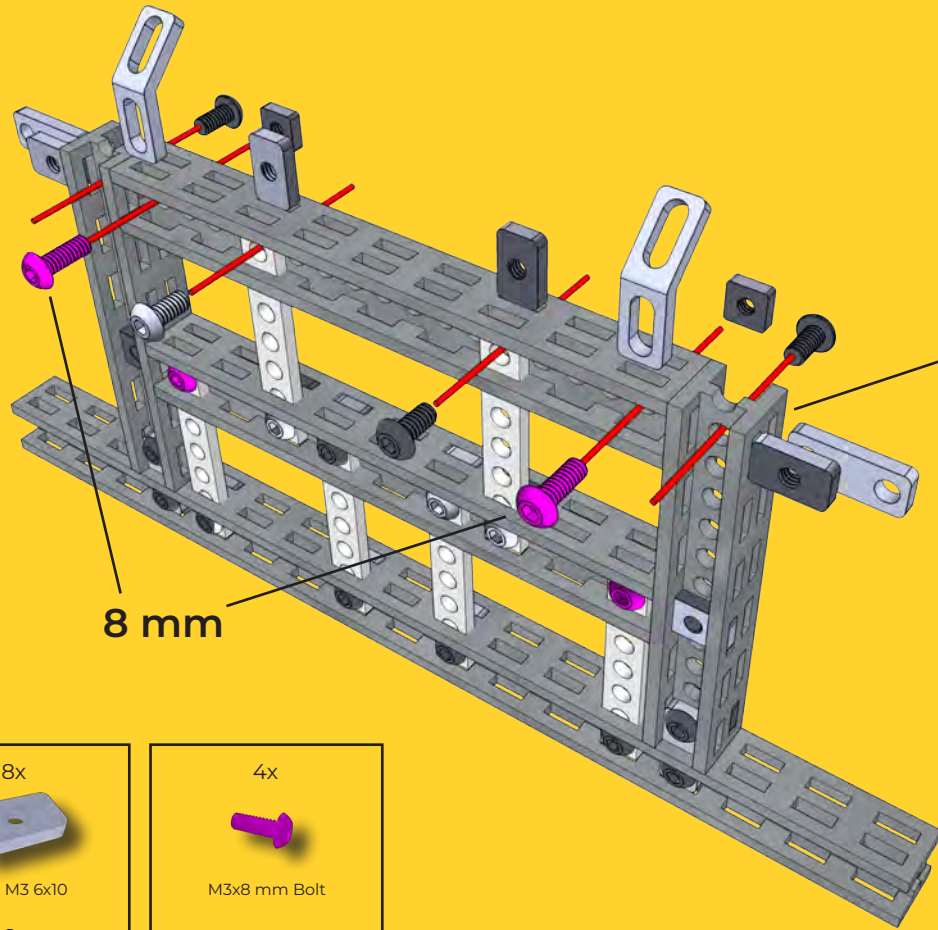
2x

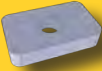

3

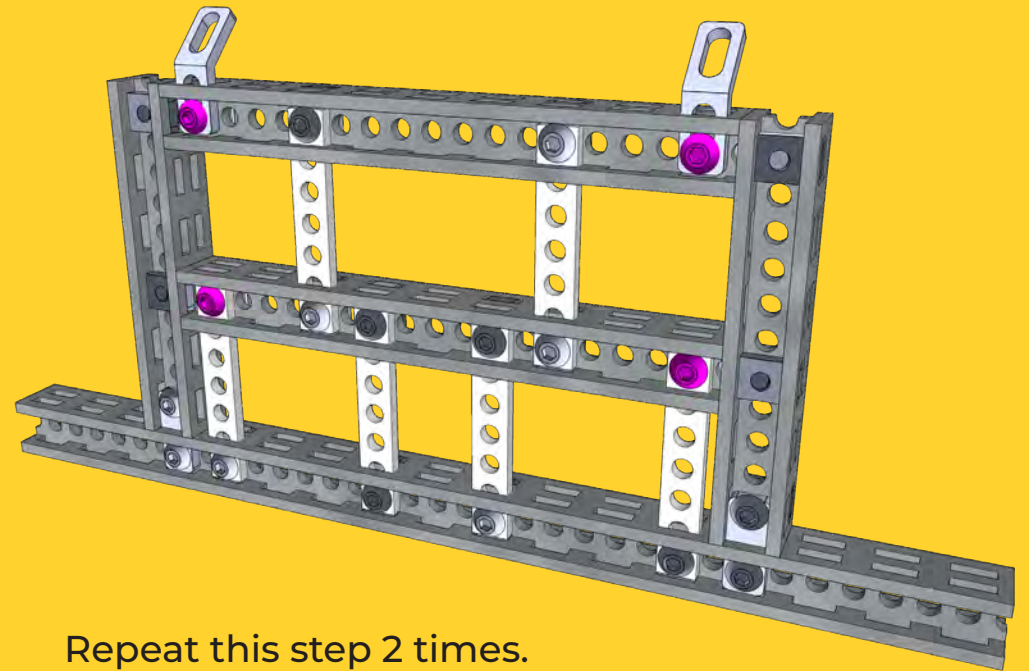

- | | |
|--|---|
| 8x

Nut M3 6x10 | 4x

M3x8 mm Bolt |
| 8x

M3x6 mm Bolt | 4x

Nut M3 6x6 |
| 4x

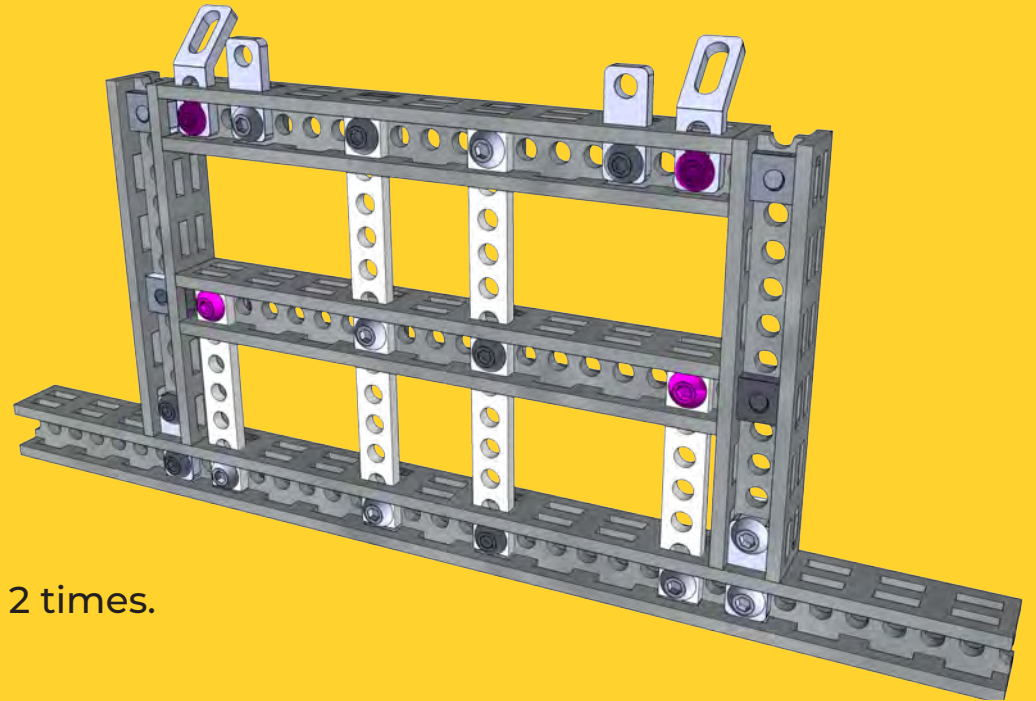
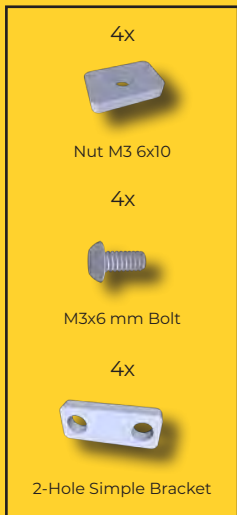
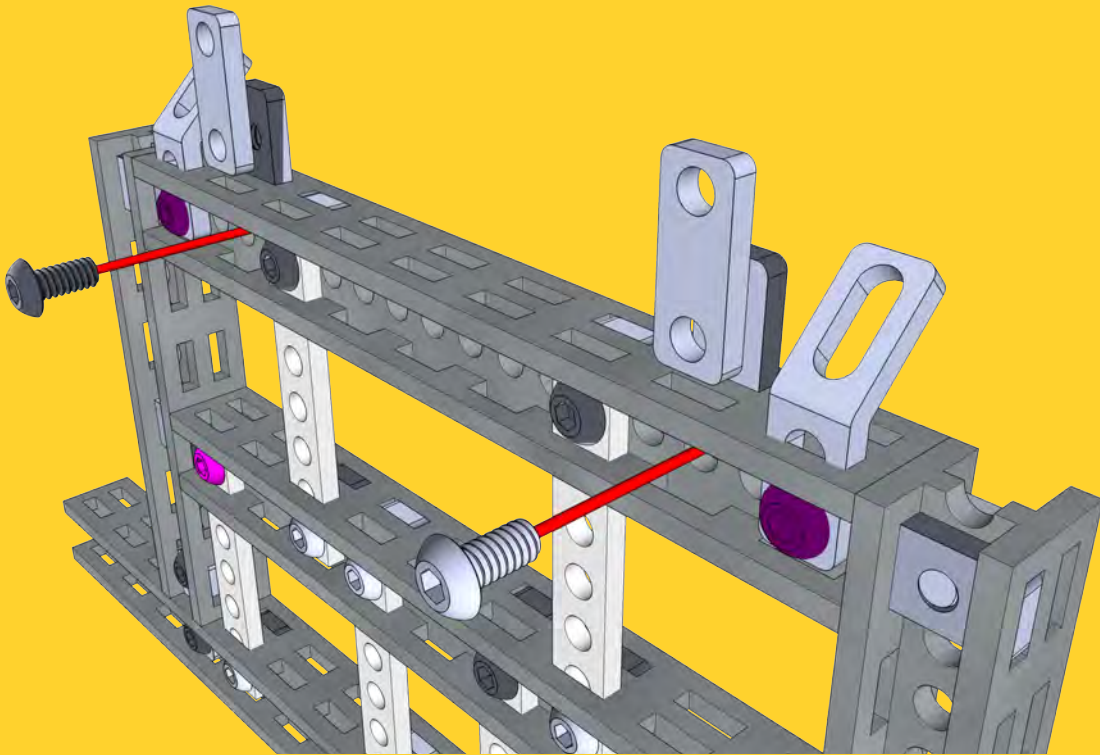
2-Hole Simple Bracket | 2x

9 cm Beam |
| 4x

2-Hole 45 Bracket | |



Repeat this step 2 times.

2x



4

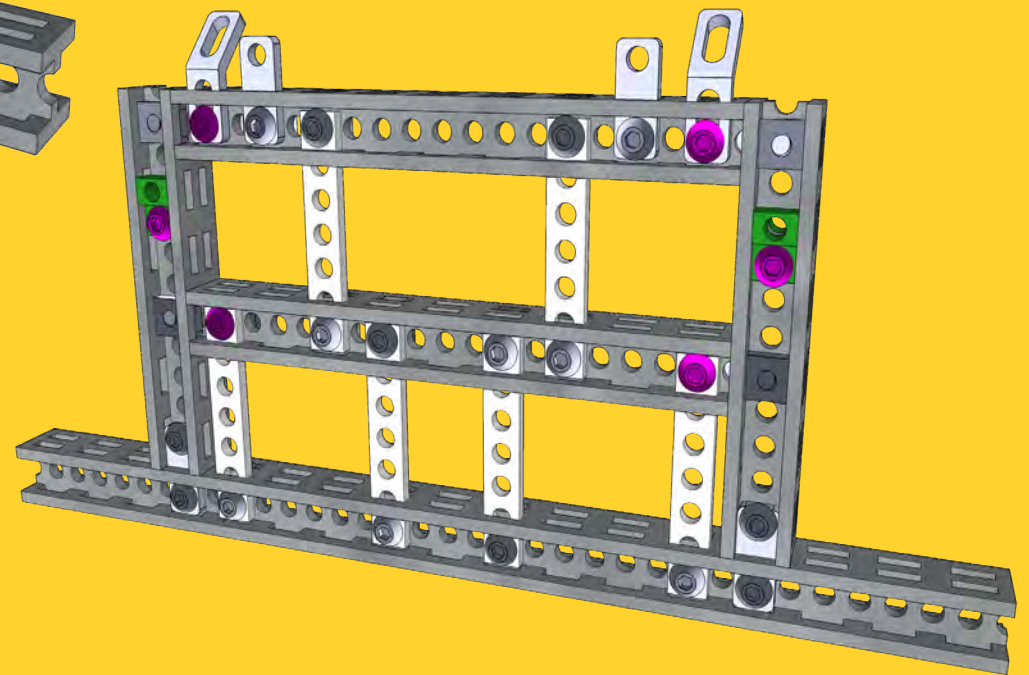
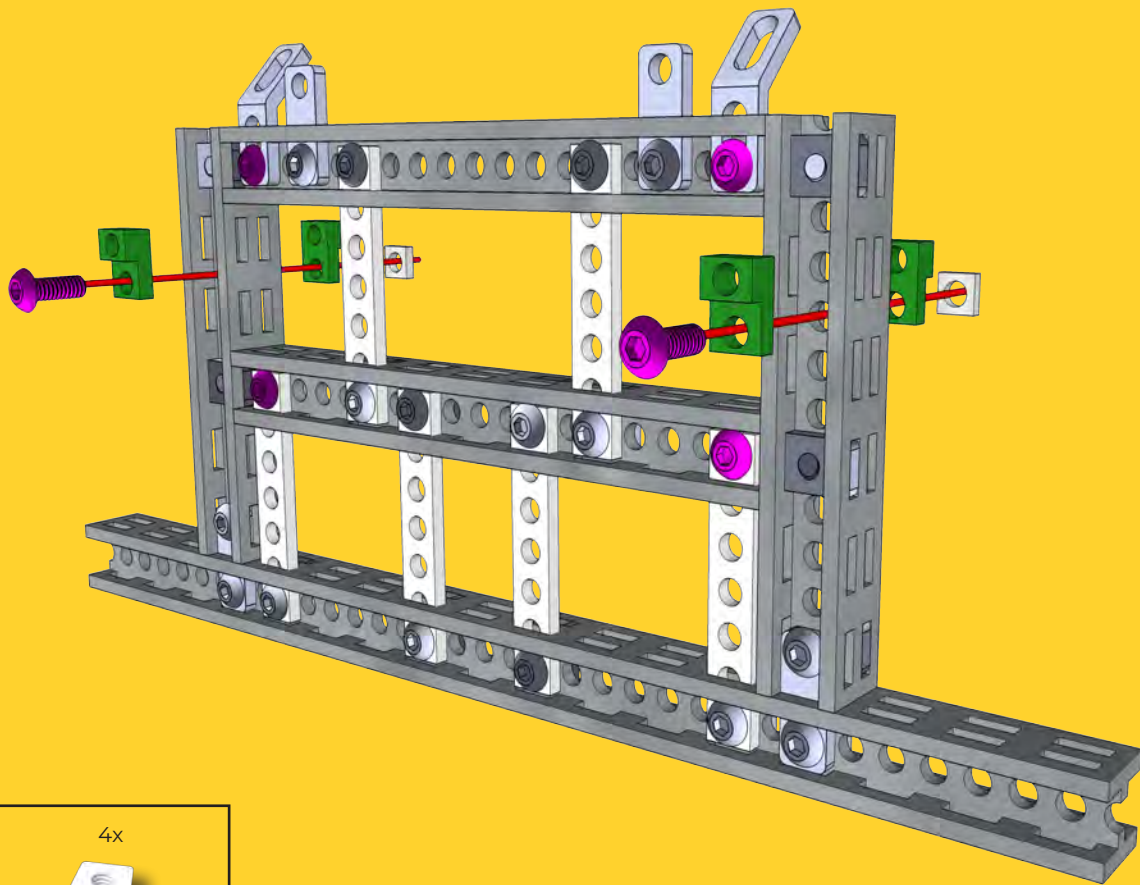

Repeat this step 2 times.

2x





- 4x

Nut M3 6x6
- 4x

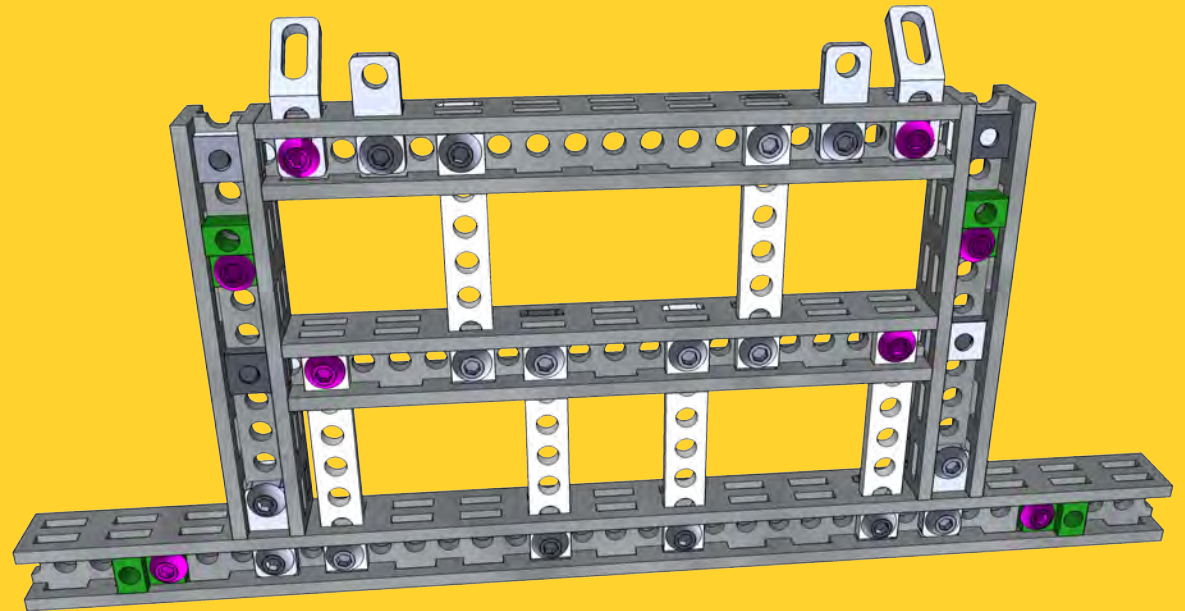
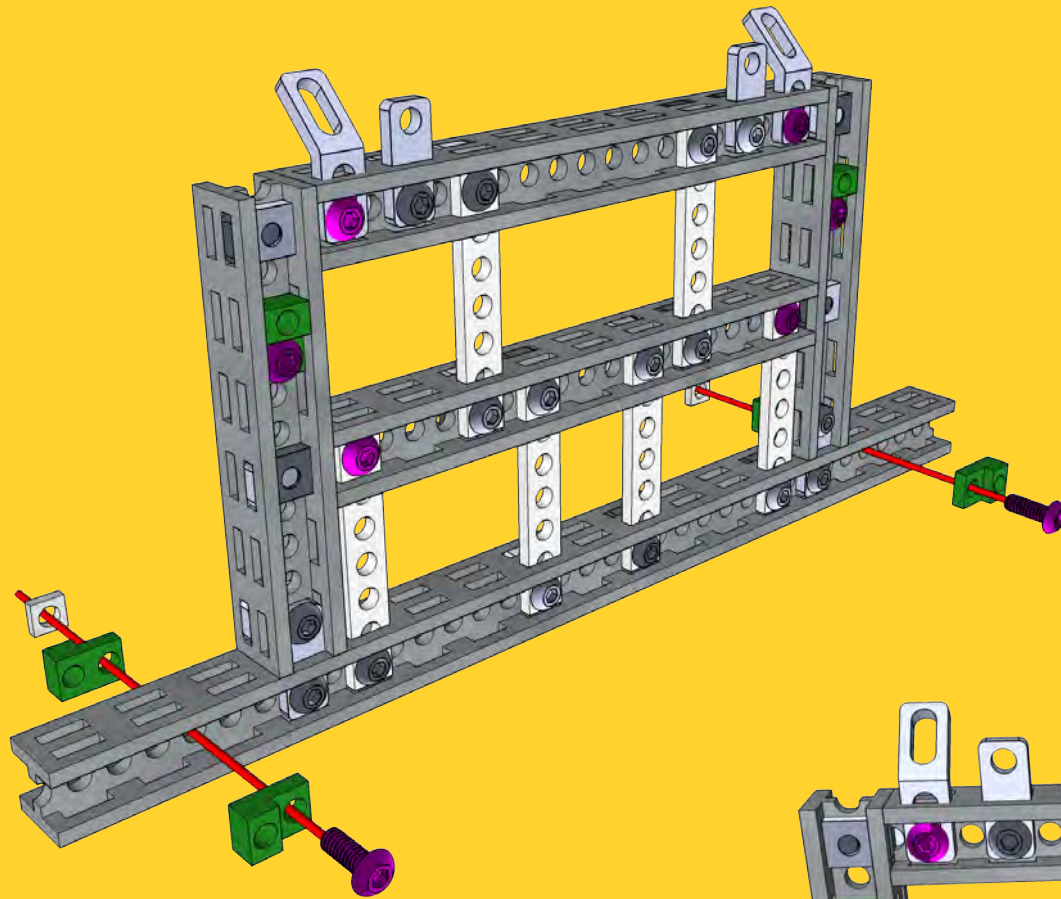
M3x8 mm Bolt
- 8x

Beam Plug

Repeat this step 2 times.

2x



- 4x

Nut M3 6x6
- 4x

M3x8 mm Bolt
- 8x

Beam Plug

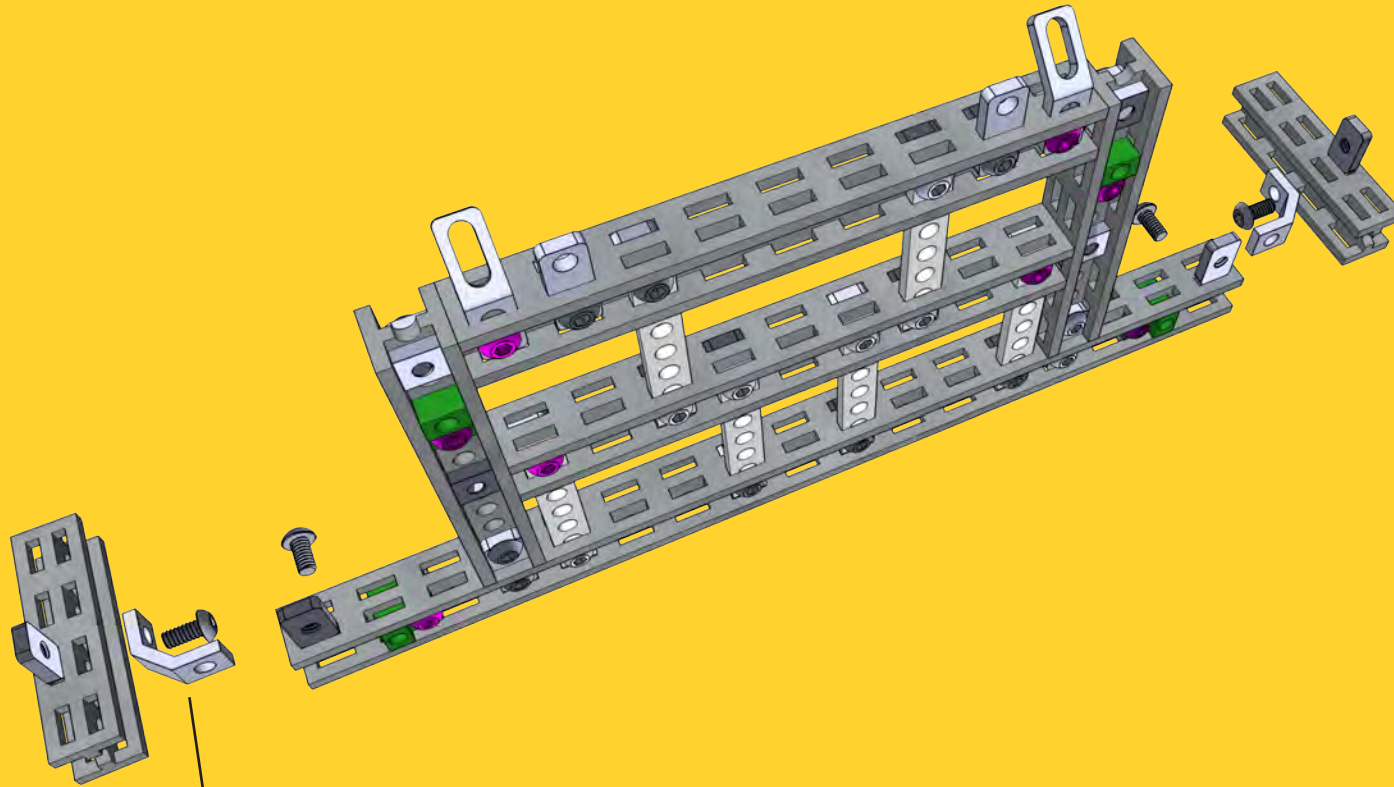
Repeat this step 2 times.

2x

7



- 8x
M3x6 mm Bolt
- 4x
C-Bracket
- 8x
Nut M3 6x10
- 4x
4 cm Beam

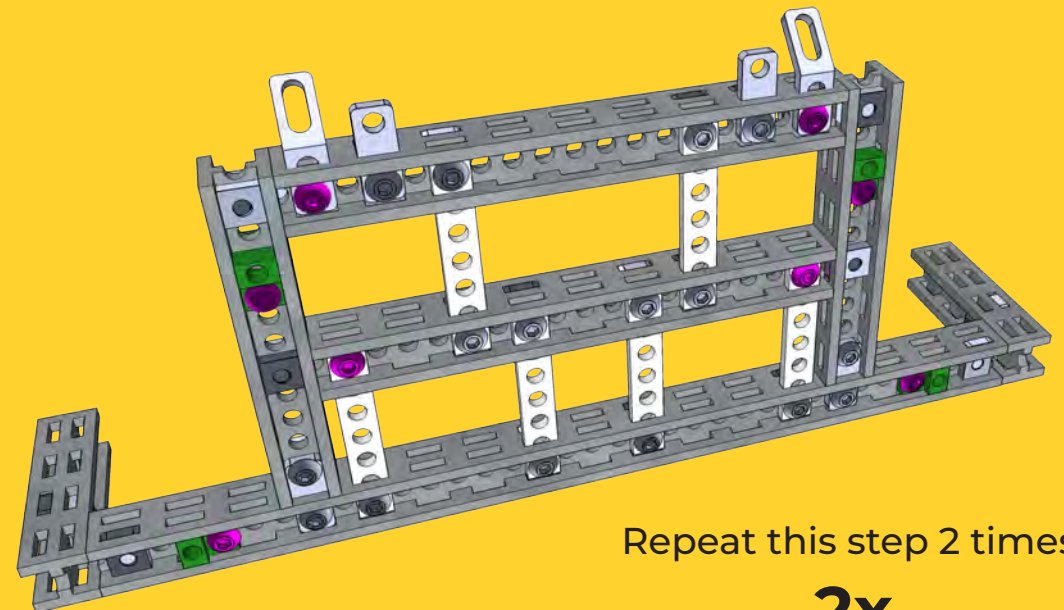
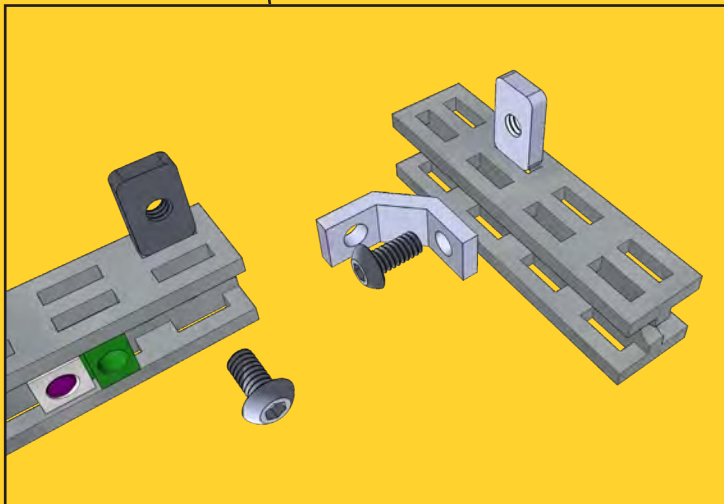



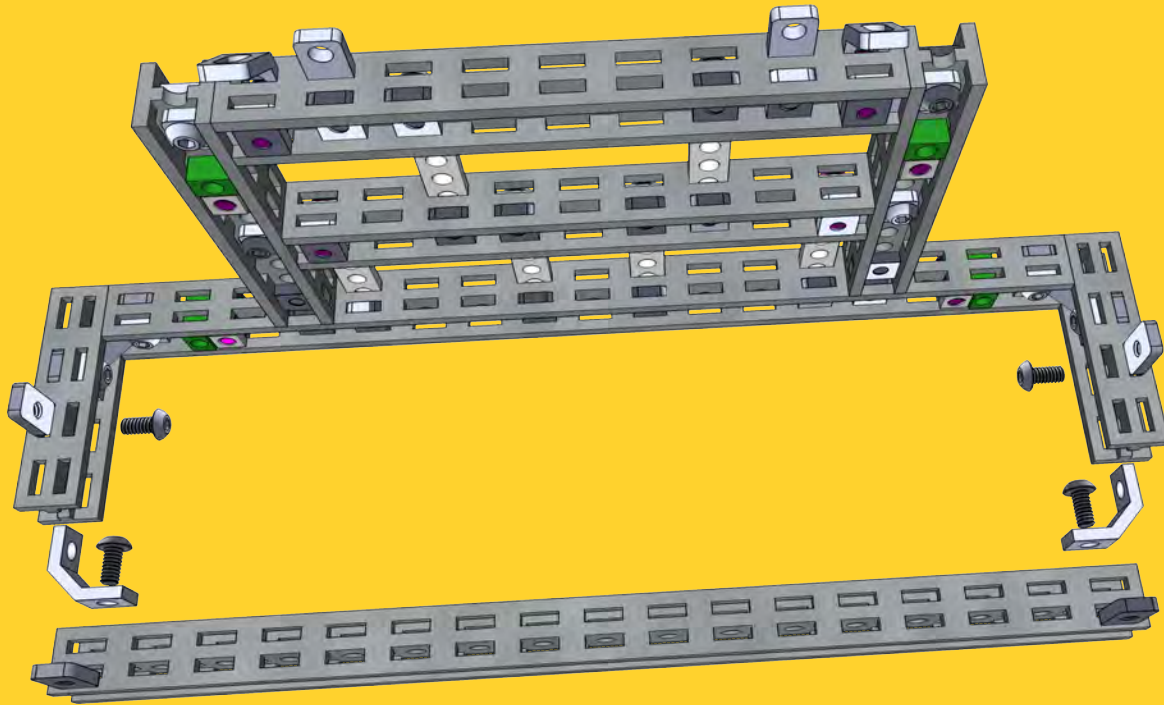

Repeat this step 2 times.

2x



17 cm

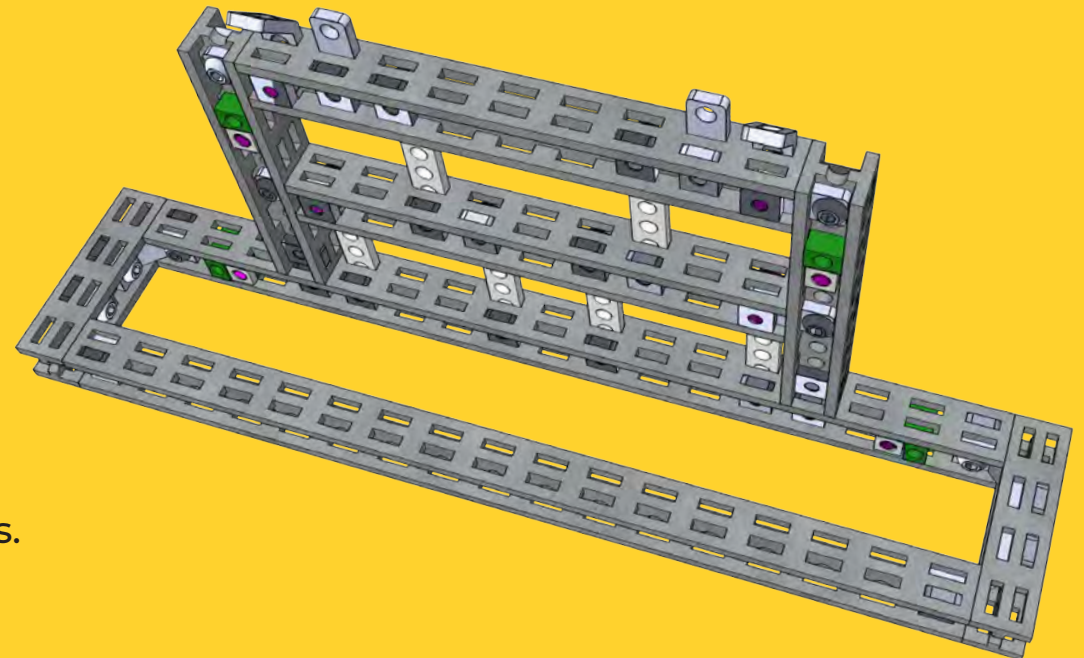

- 8x

M3x6 mm Bolt
- 4x

C-Bracket
- 8x

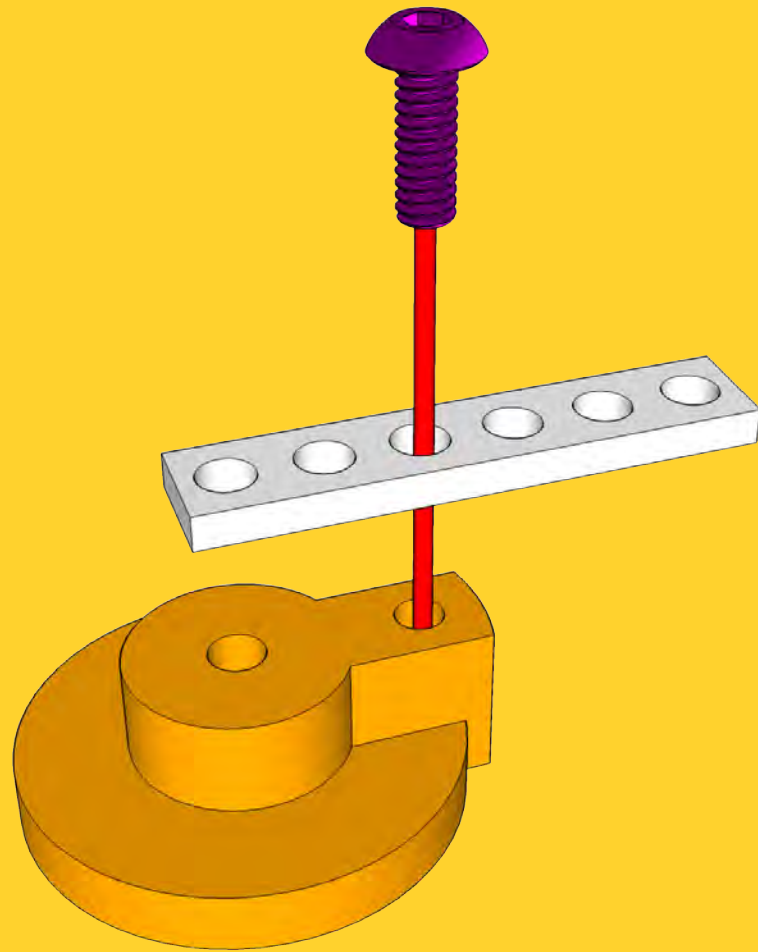
Nut M3 6x10
- 2x

17 cm Beam



Repeat this step 2 times.

2x



- 8x

M3x8 mm Bolt
- 8x

Rocker
- 8x

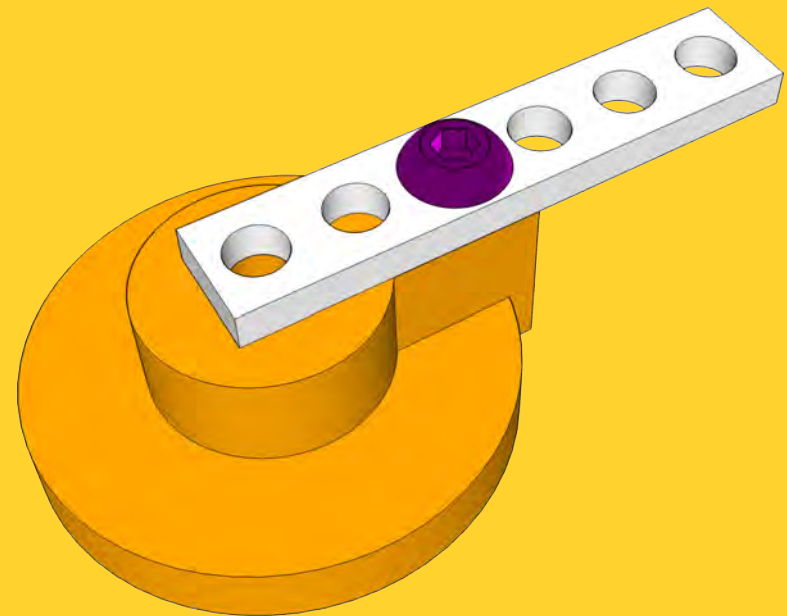
3 cm/6 Holes
Strip Bracket

Repeat this step 8 times.

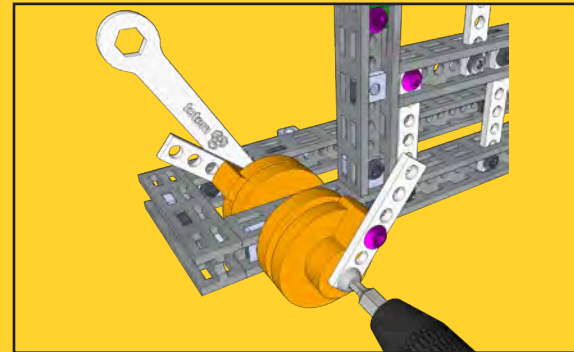
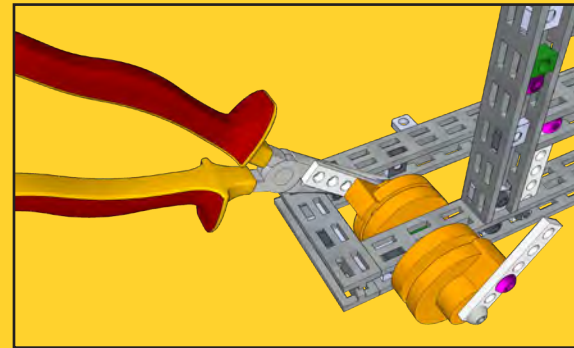
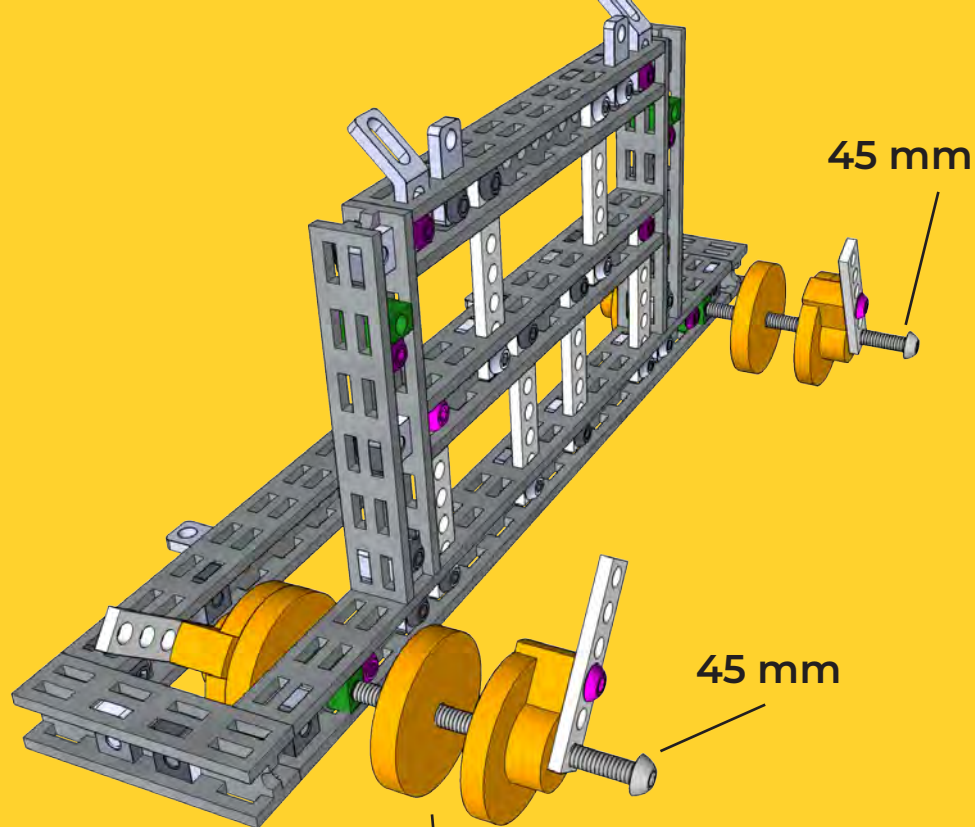

8x



10



Use pliers or Totem wrench to hold the nut when screwing in the bolt.

- 4x

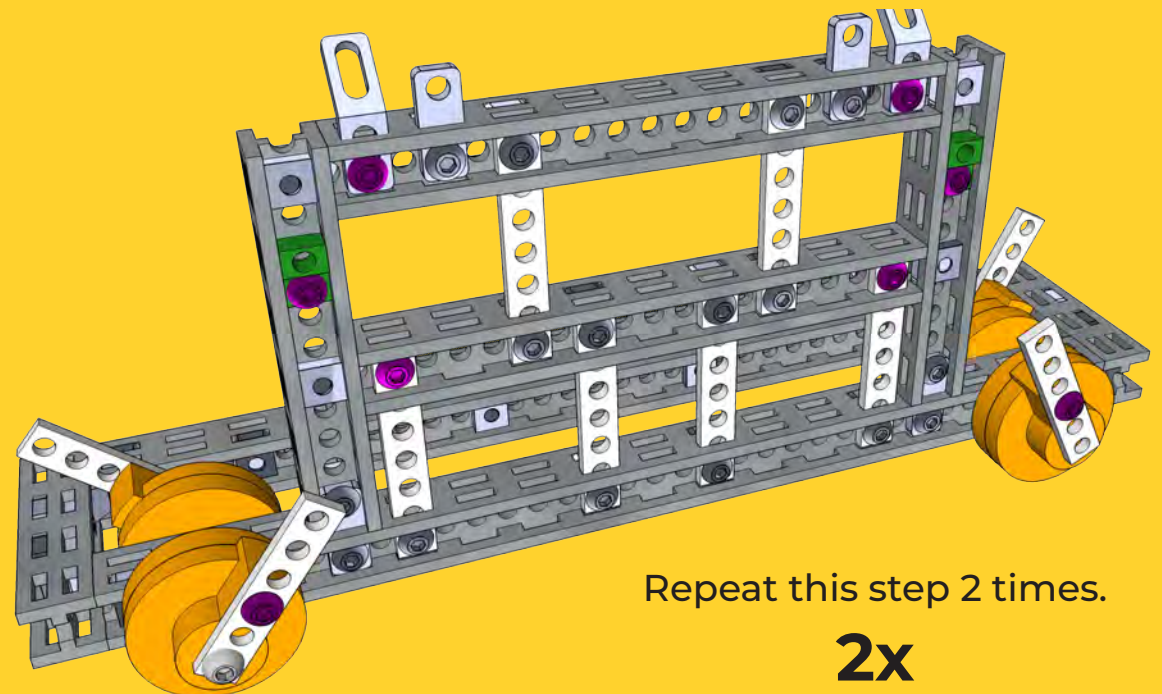
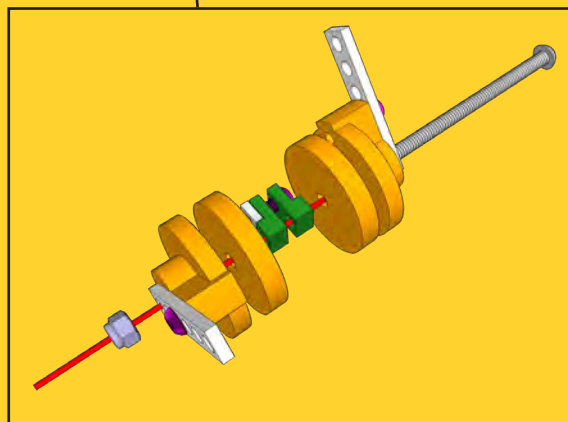
Lock Nut M3
- 4x

M3x45 mm Bolt
- 8x

Rocker Washer

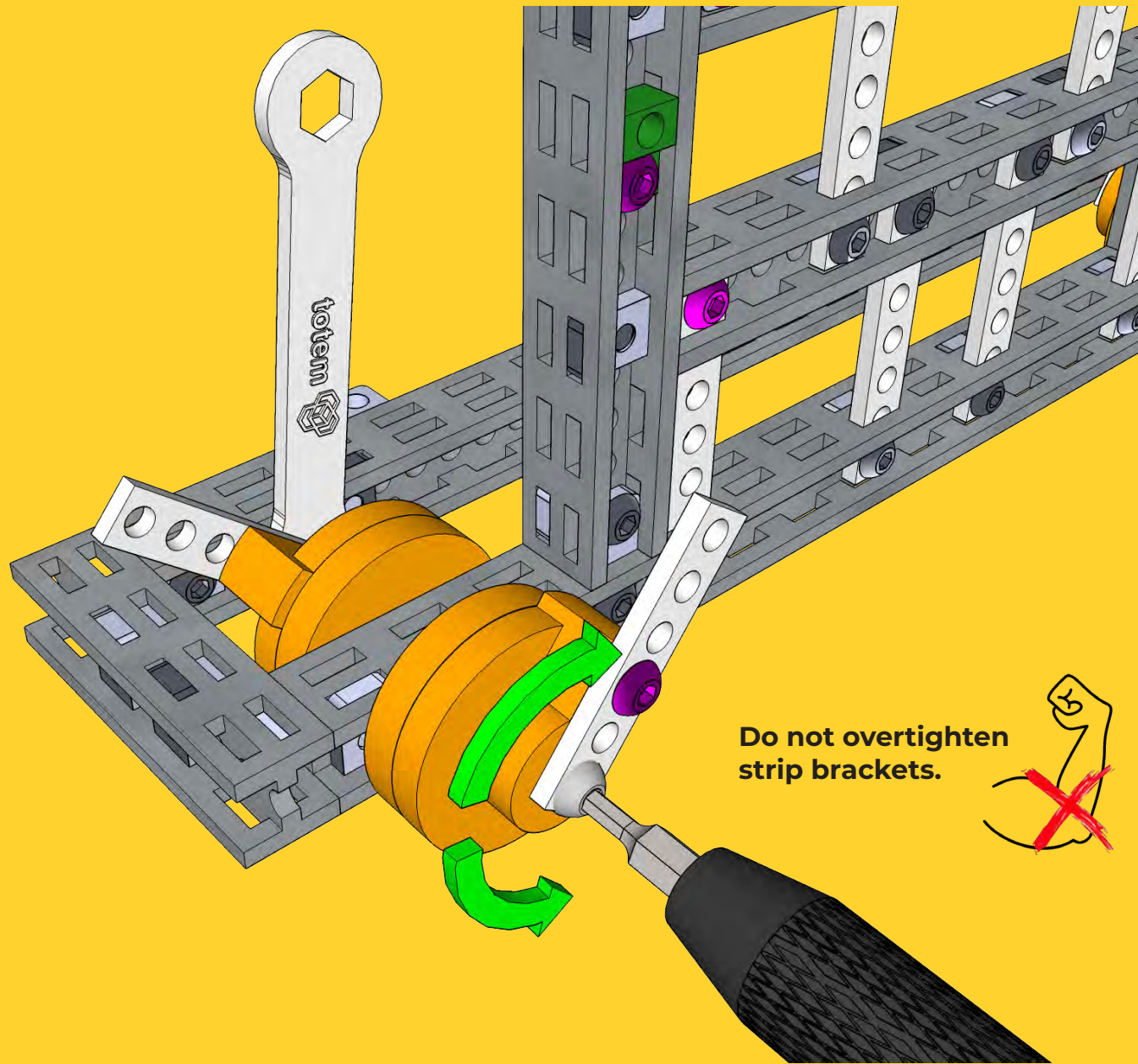

Repeat this step 2 times.

2x



Repeat this step 4 times.

4x

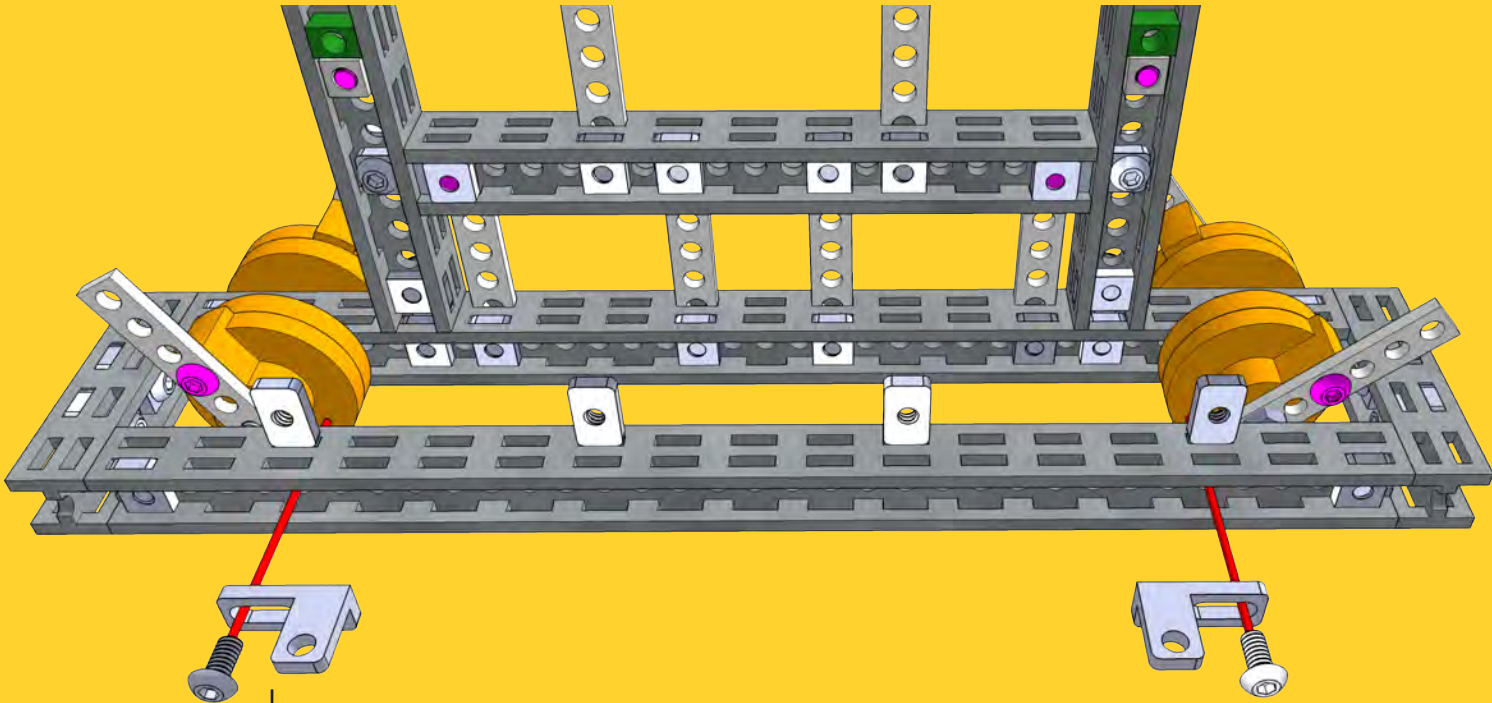

- 4x

M3x6 mm Bolt
- 8x

Nut M3 6x10
- 2x

L-Twisted Mirror Bracket
- 2x

L-Twisted Bracket

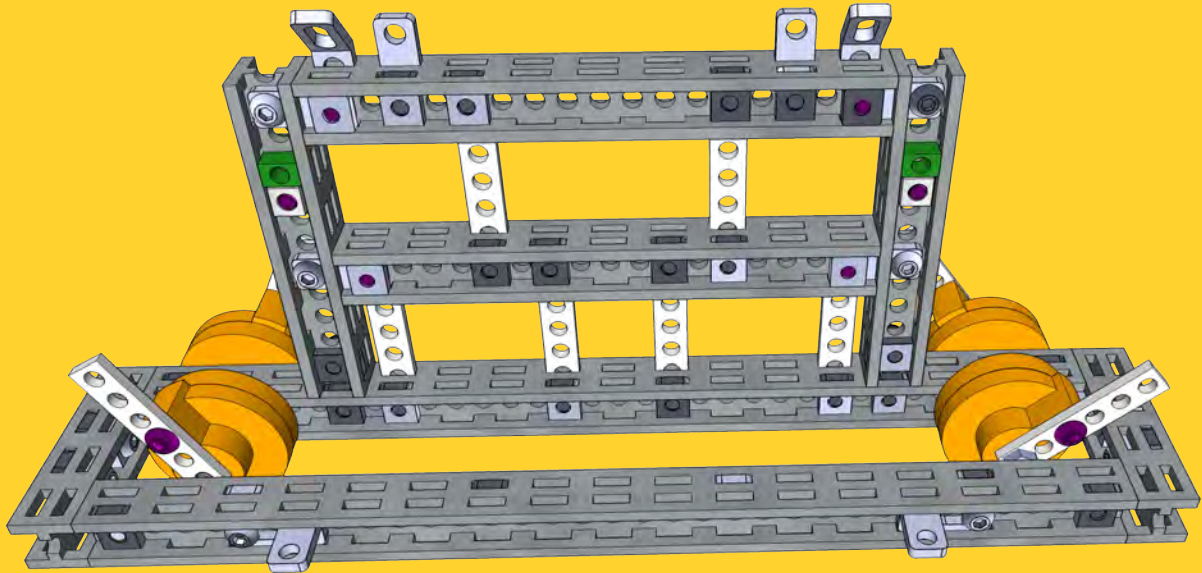
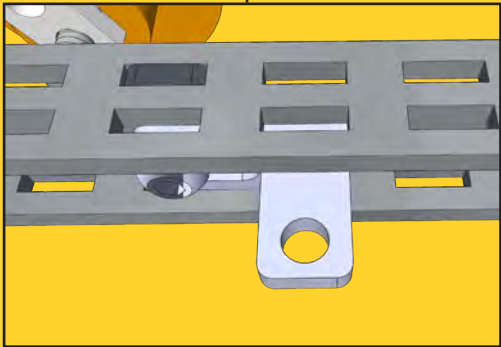

Repeat this step 2 times.

2x

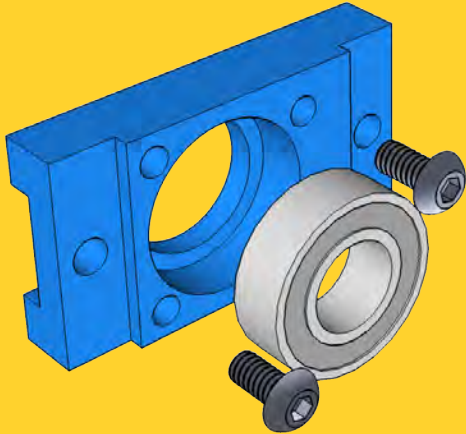
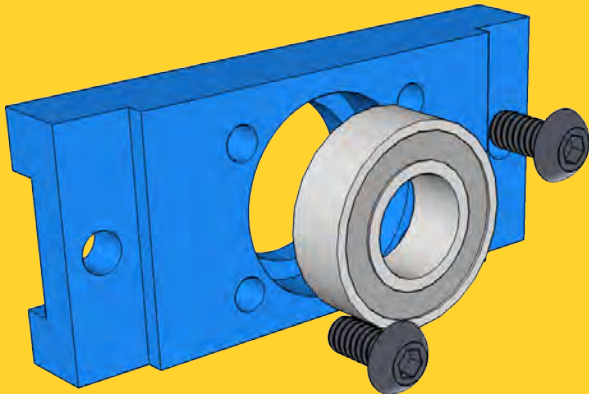

Repeat this step 2 times.

2x

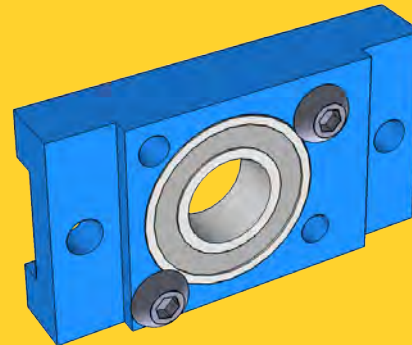
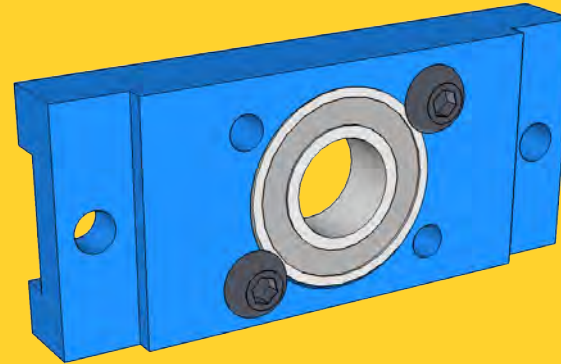

Repeat this step 4 times.

4x

- 12x

M3x6 mm Bolt
- 2x



Upper Gear Hub
- 4x

Lower Gear Hub
- 6x

Bearing 8x16x5

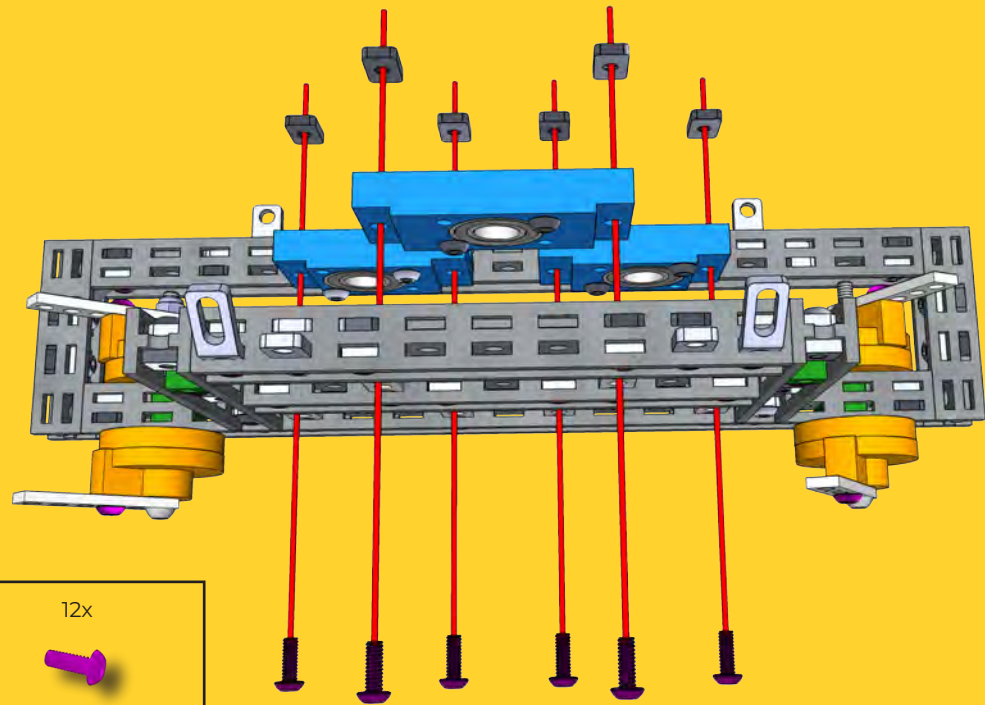
Make sure the blue bearing hubs are positioned correctly. The bearings are in the outer position. See below:



- 12x  M3x8 mm Bolt
- 12x  Nut M3 6x10

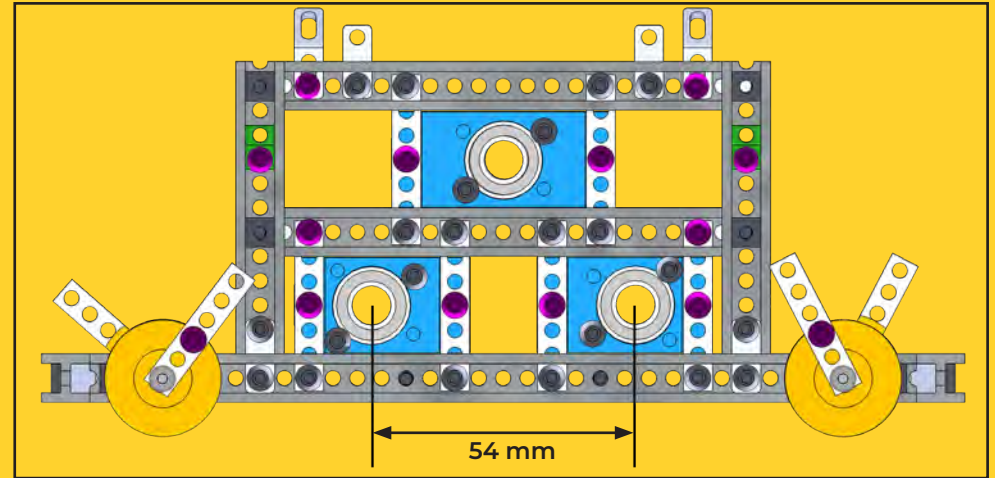
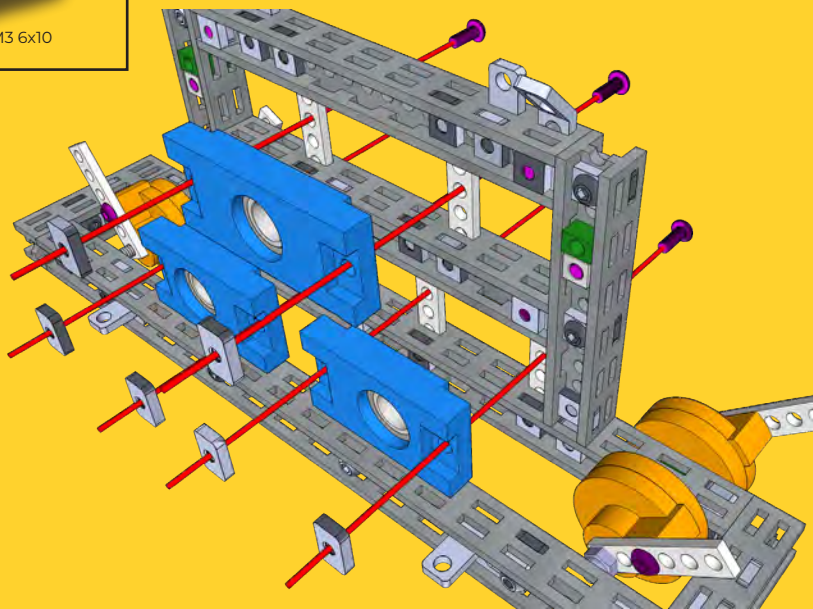

PART 2

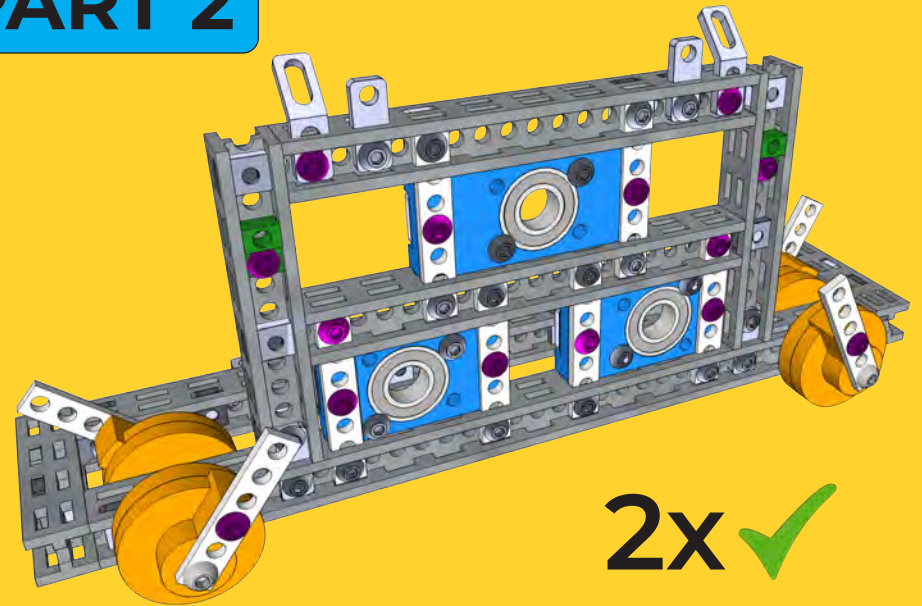

2x 

PART 3

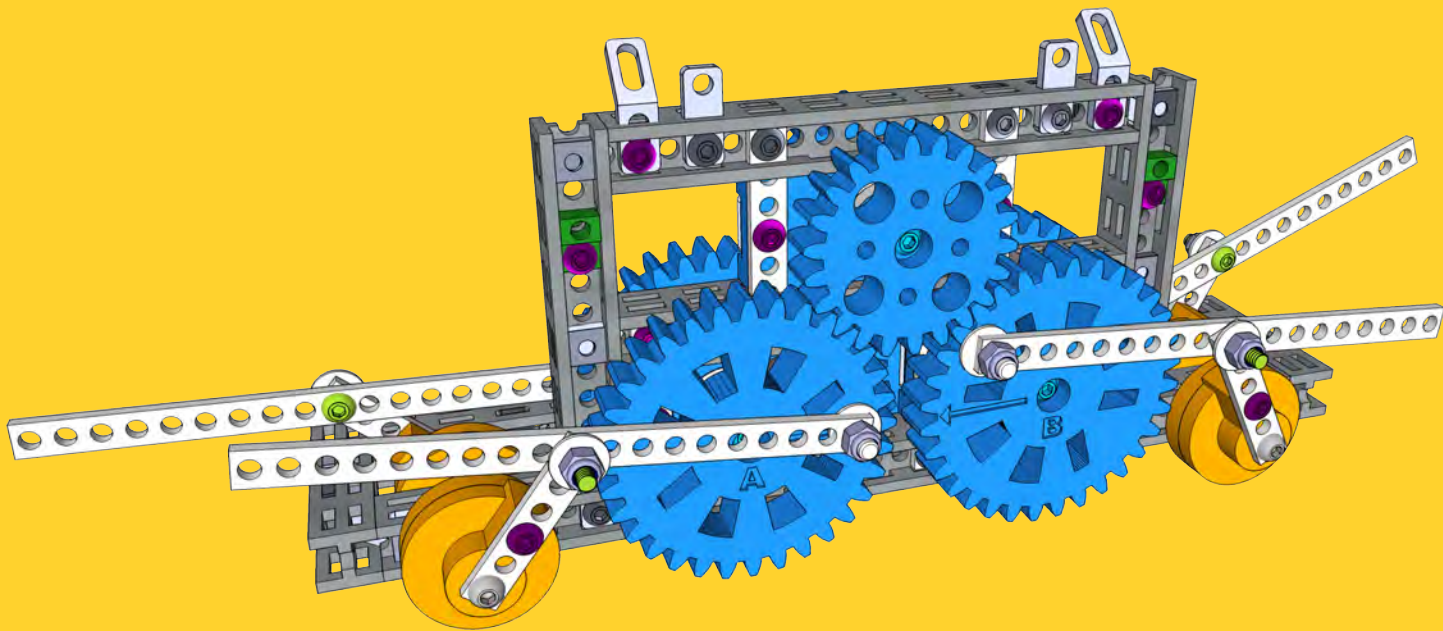

2x

- 8x

M3x8 mm Bolt
- 8x

M3x12 mm Bolt
- 6x









M3x25 mm Bolt
- 8x

M3-HEXH 12 mm Bolt
- 16x

Lock Nut M3
- 16x

Washer 9/0.8mm M3
- 1x

Metal Nut M3
- 2x

Motor Coupler 6 mm

- 6x

Nut M3 6x10
- 2x

Upper Gear A
- 2x

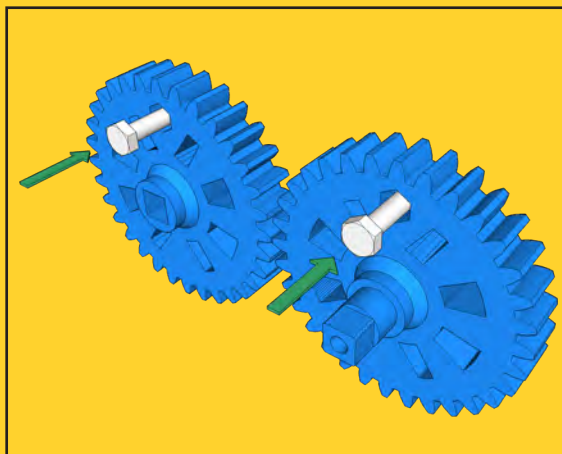
Upper Gear B
- 2x

Lower Gear A
- 2x

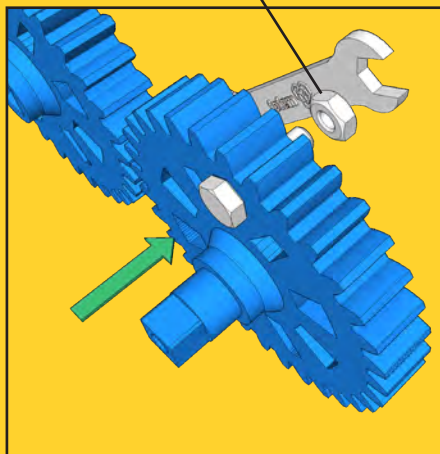
Lower Gear B
- 2x

Lower Gear C
- 2x

Lower Gear D
- 8x

9.5 cm/19 Holes
Strip Bracket

Metal nut helps to press bolt into gear.

1



1



2

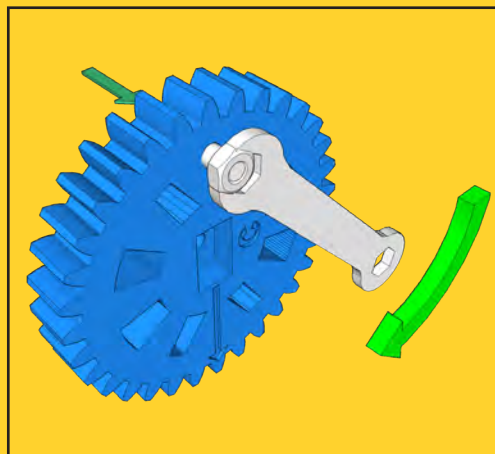

3

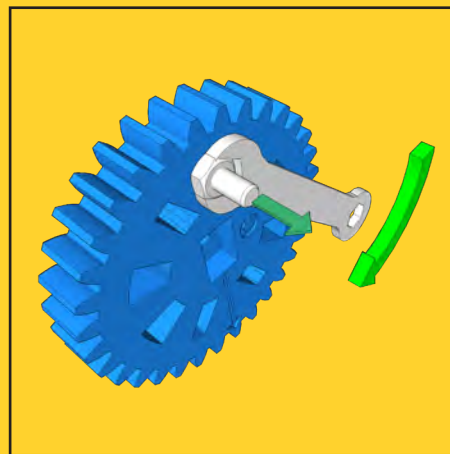

4

Insert bolts as deep as possible (min 2 mm).

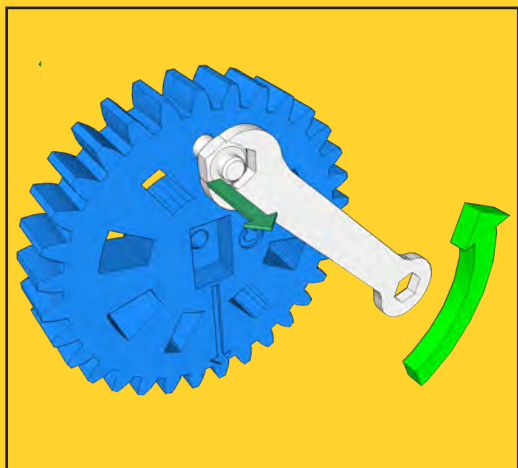

5

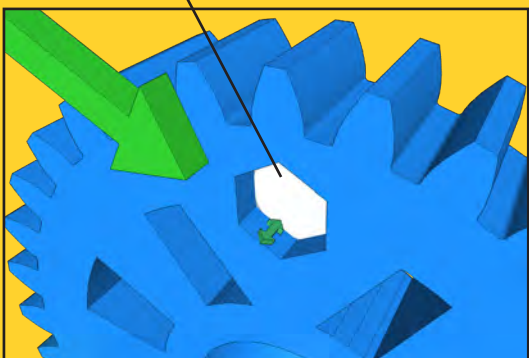

6

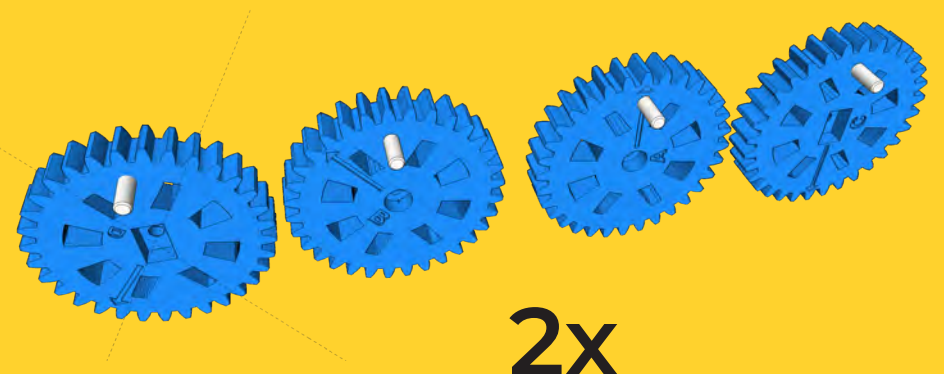

2x

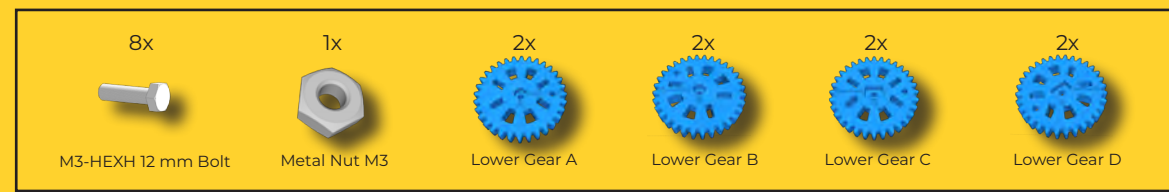

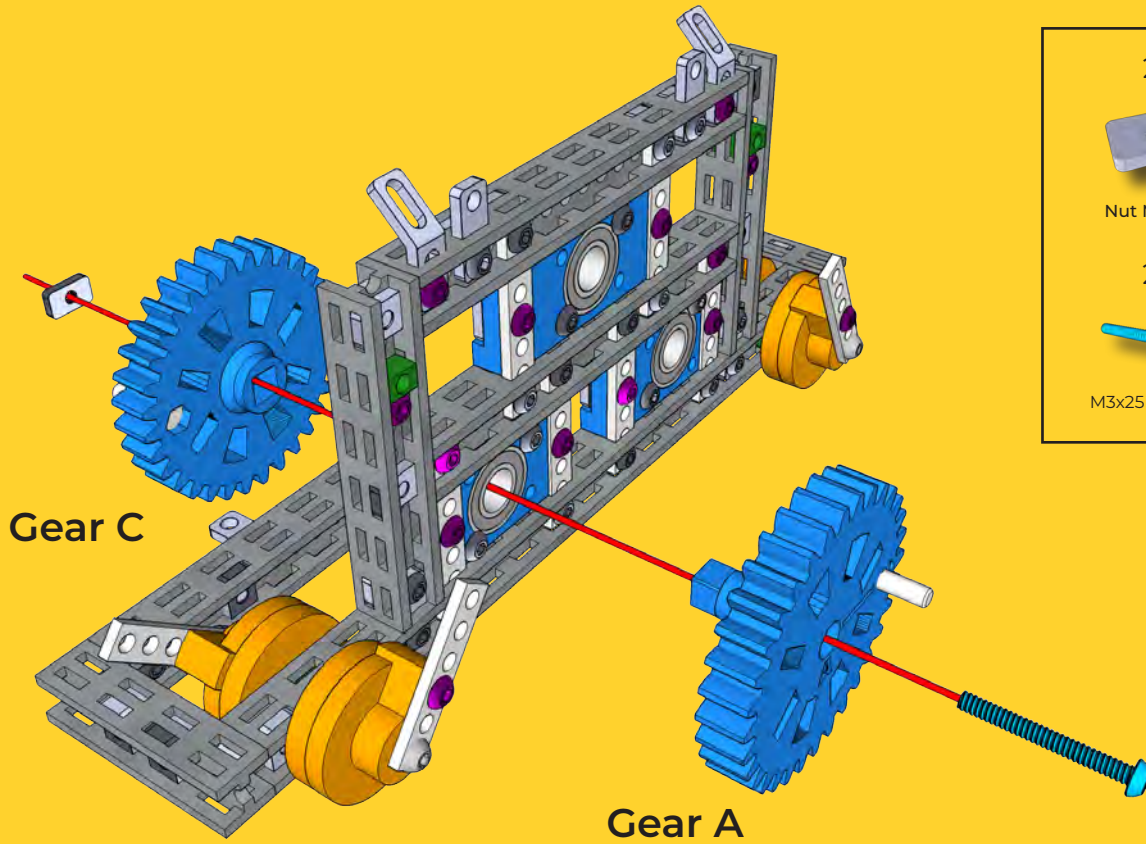

2



2x

 Nut M3 6x10
 2x

 M3x25 mm Bolt

2x

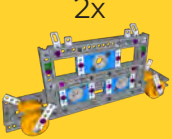
 Lower Gear A
 2x

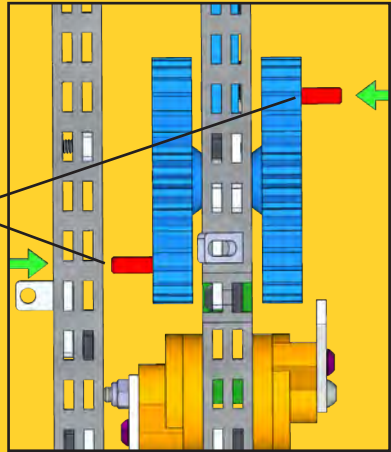
 Lower Gear C

2x

 Part 2

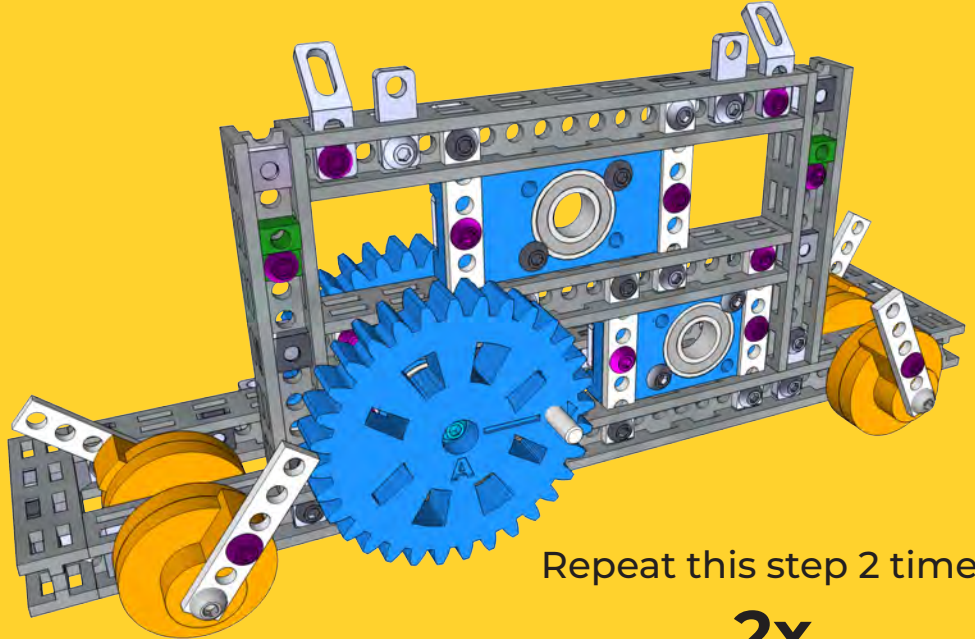
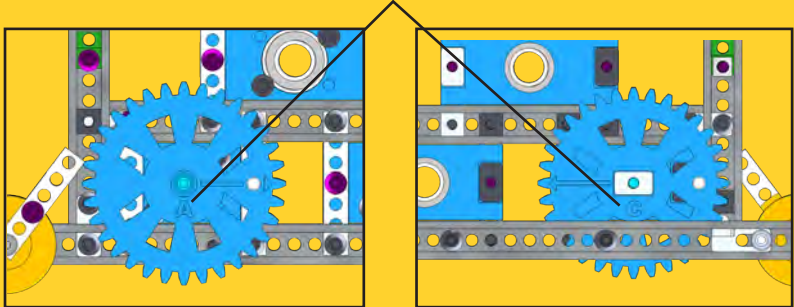

Bolts (in red) will be diagonally opposite to each other.

Letters "A" and "C" identify the gears, in the middle of the parts.



Repeat this step 2 times.

2x

3

Letters "A", "B", "C", "D" identify the gears.

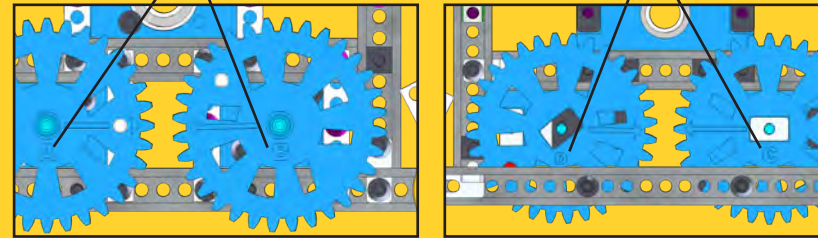

Gear D

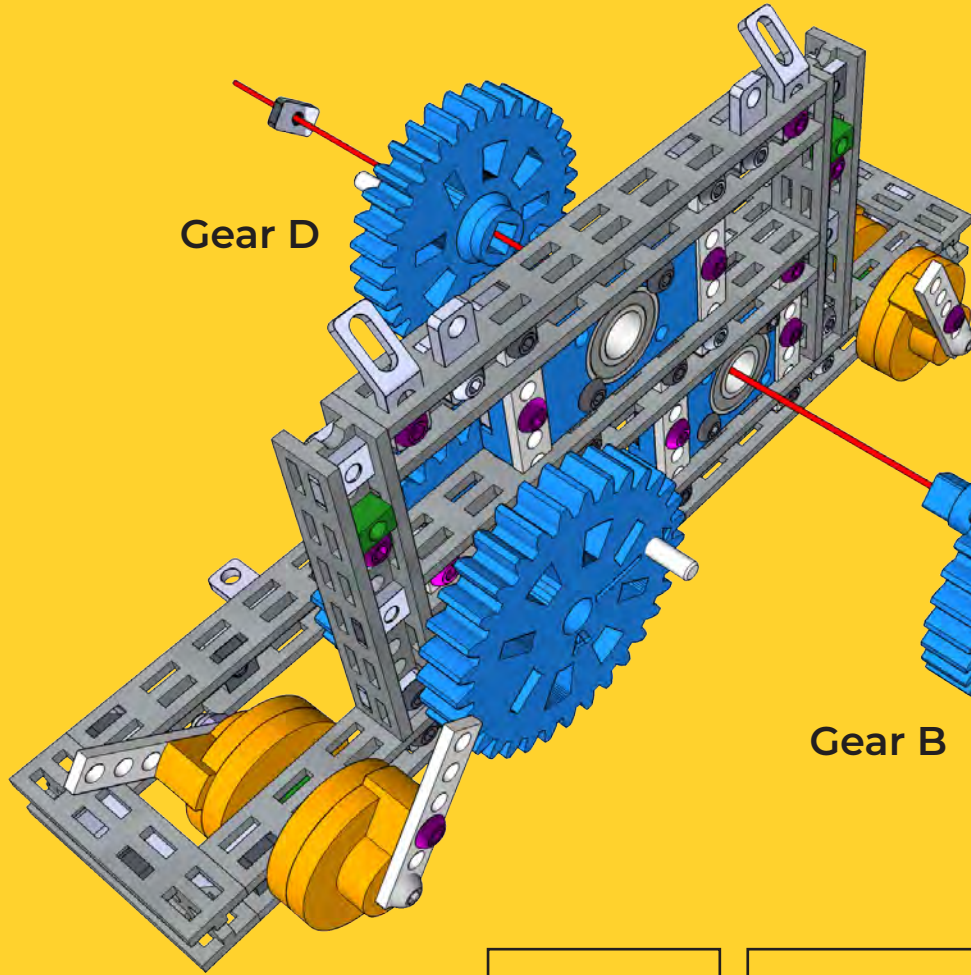

Gear B

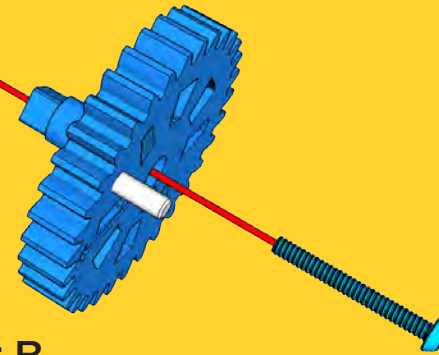

Bolts (in red) will be diagonally opposite to each other.

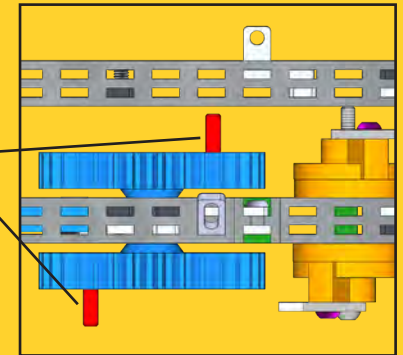

2x



Nut M3 6x10

2x

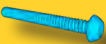

M3x25 mm Bolt

2x



Lower Gear B

2x



Lower Gear D

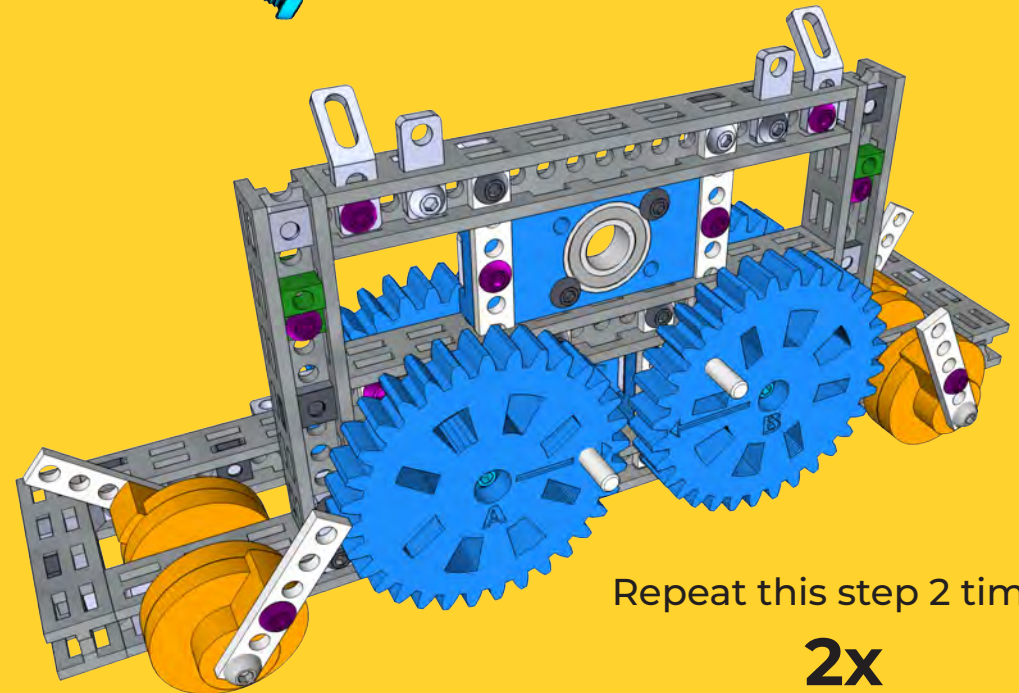

Repeat this step 2 times.

2x

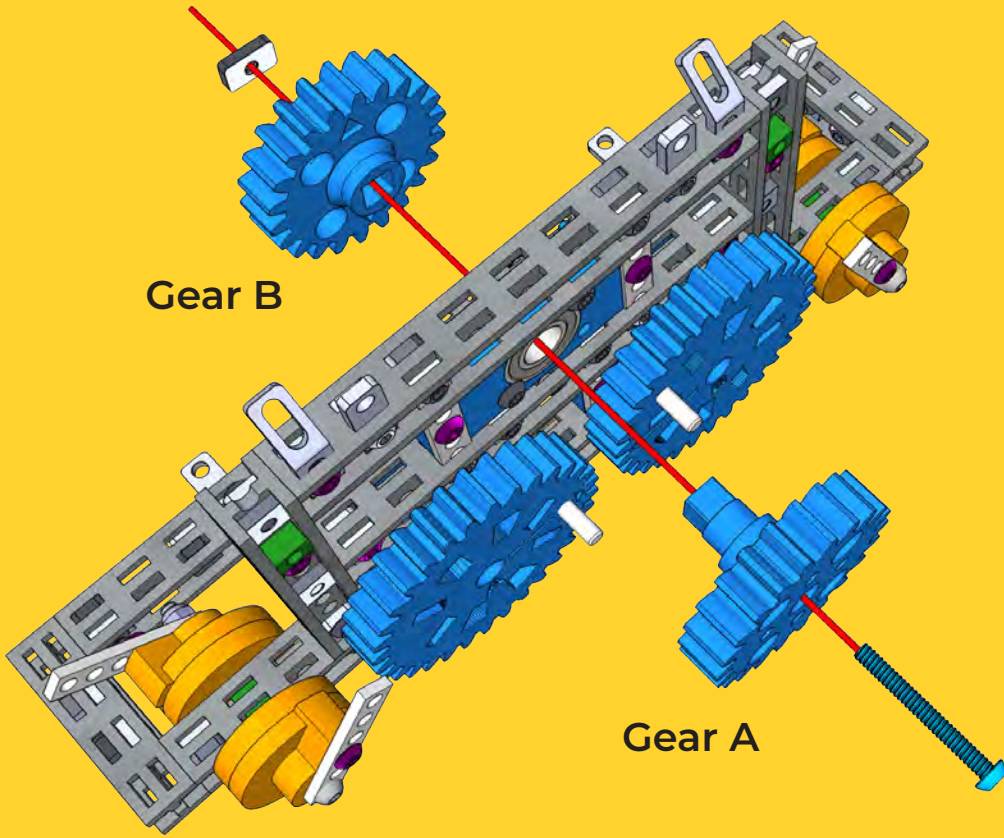

Gear B

Gear A

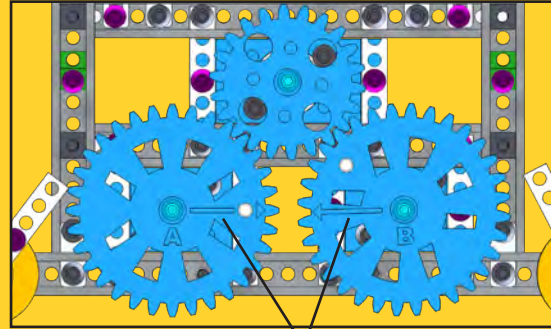

Arrows must point to each other on both sides.

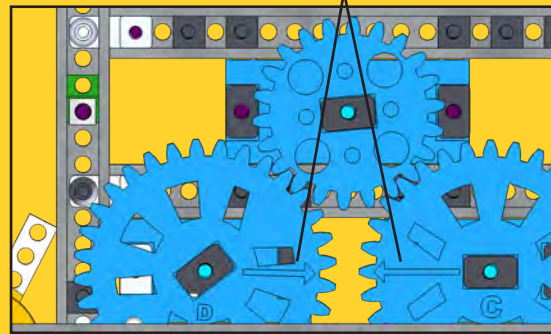

Triangles must point at the same direction on both upper gears.

2x

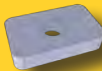

Nut M3 6x10

2x



M3x25 mm Bolt

2x



Upper Gear A

2x



Upper Gear B

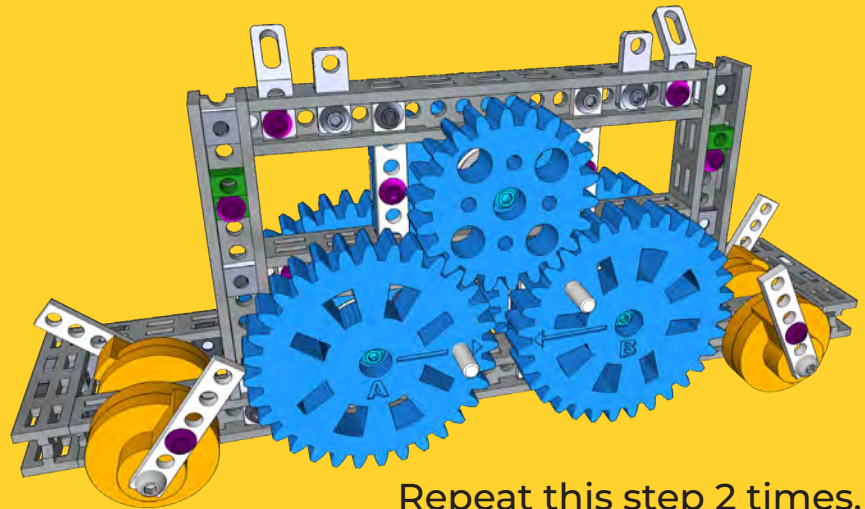
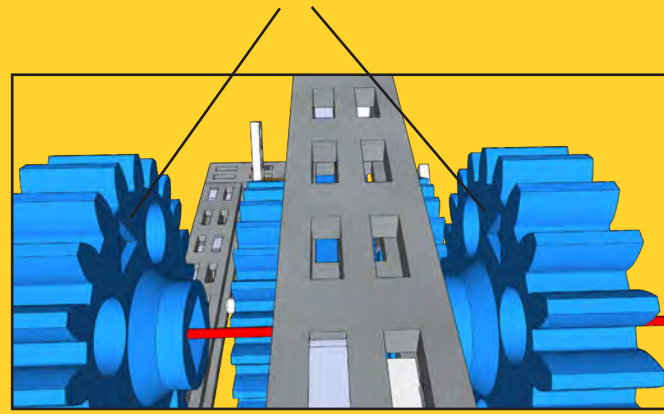

Repeat this step 2 times.

2x

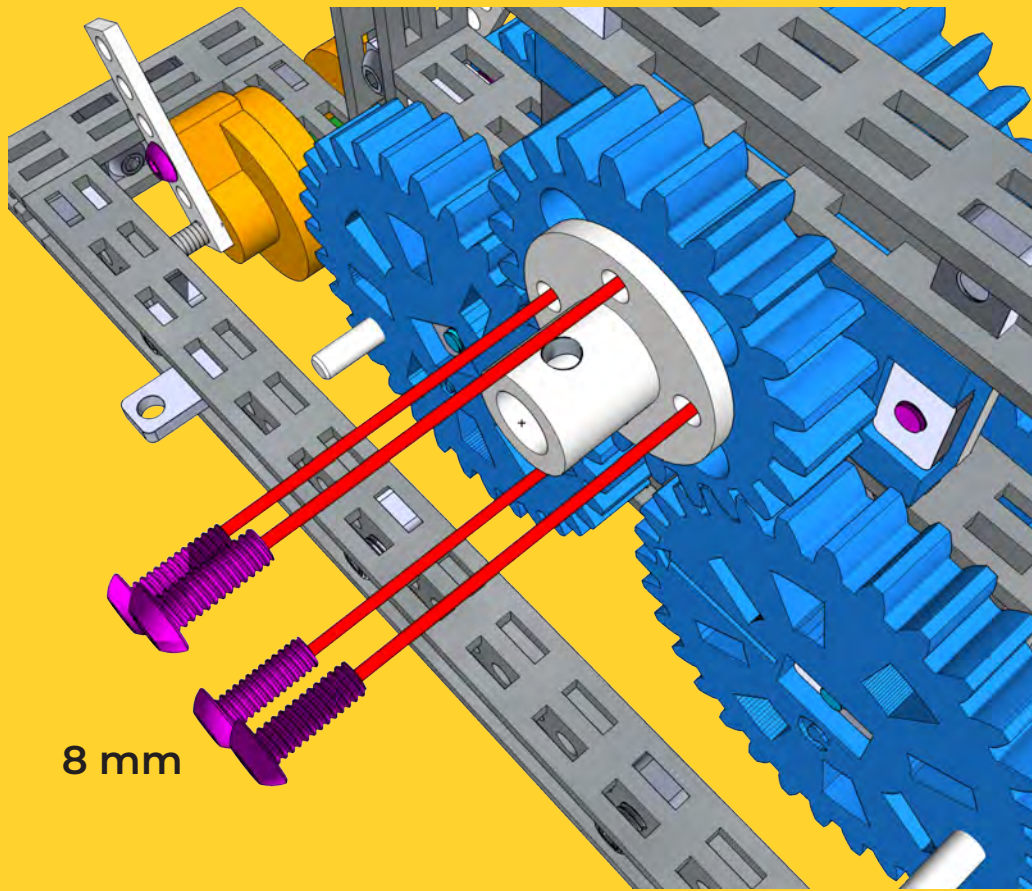

8 mm

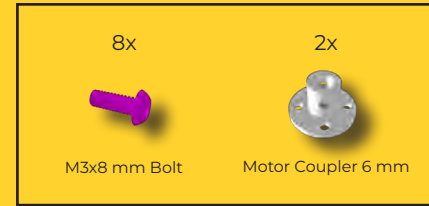

5

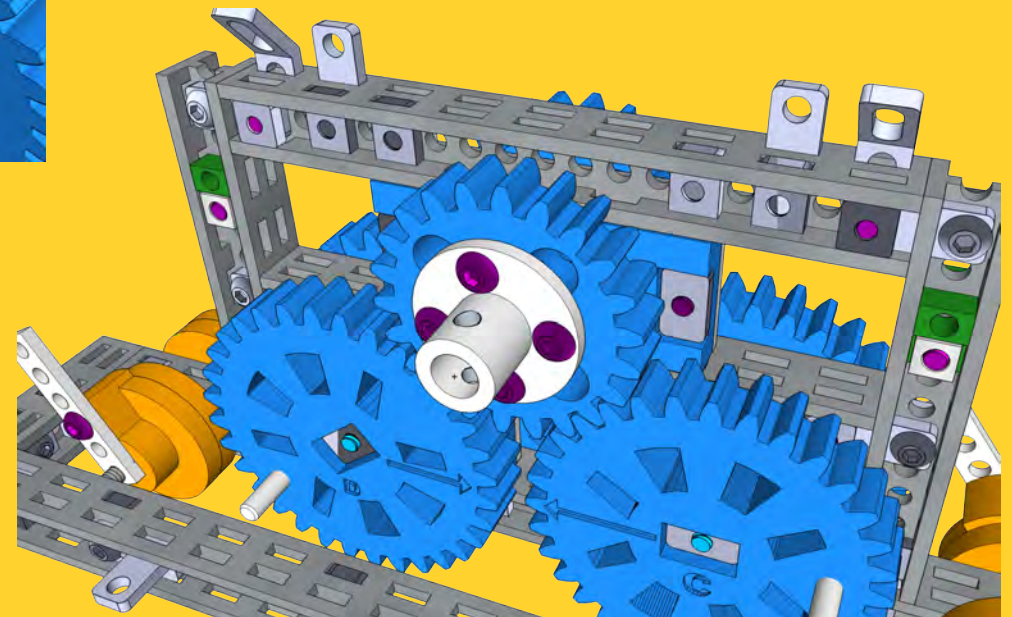

Repeat this step 2 times.

2x

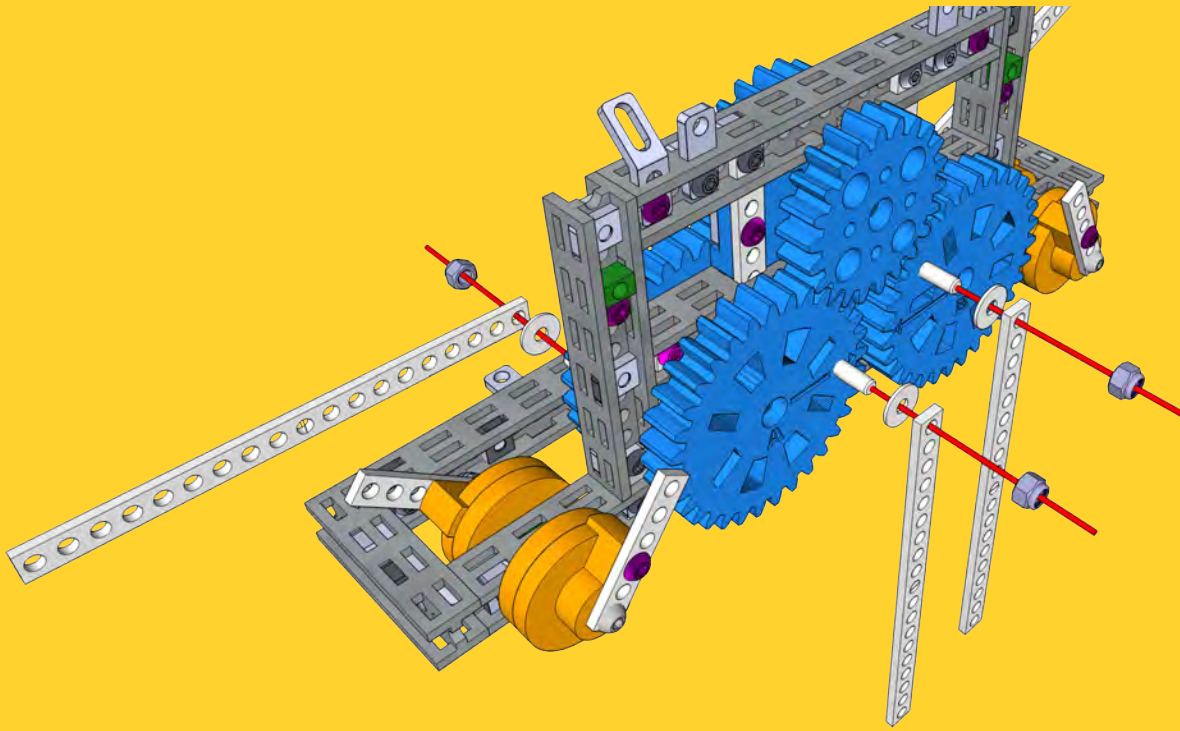

6



- 8x

Lock Nut M3
- 8x

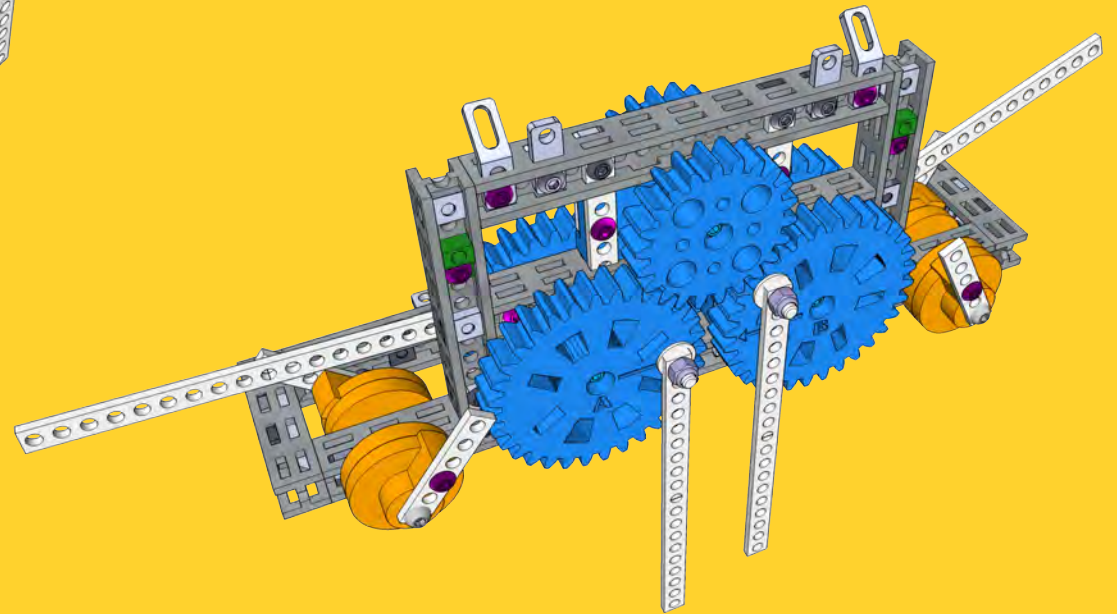
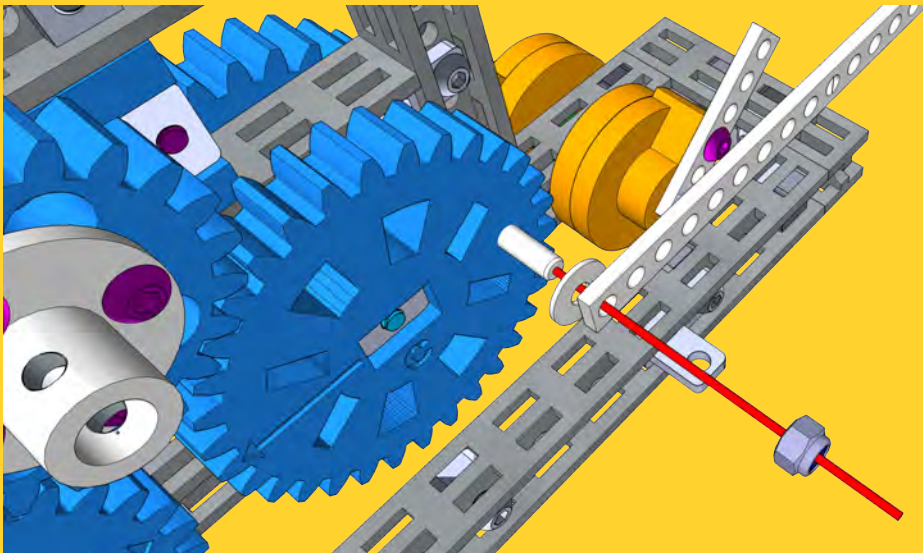
Washer 9/0.8mm M3
- 8x

9.5 cm/19 Holes
Strip Brackets







Repeat this step 2 times.

2x

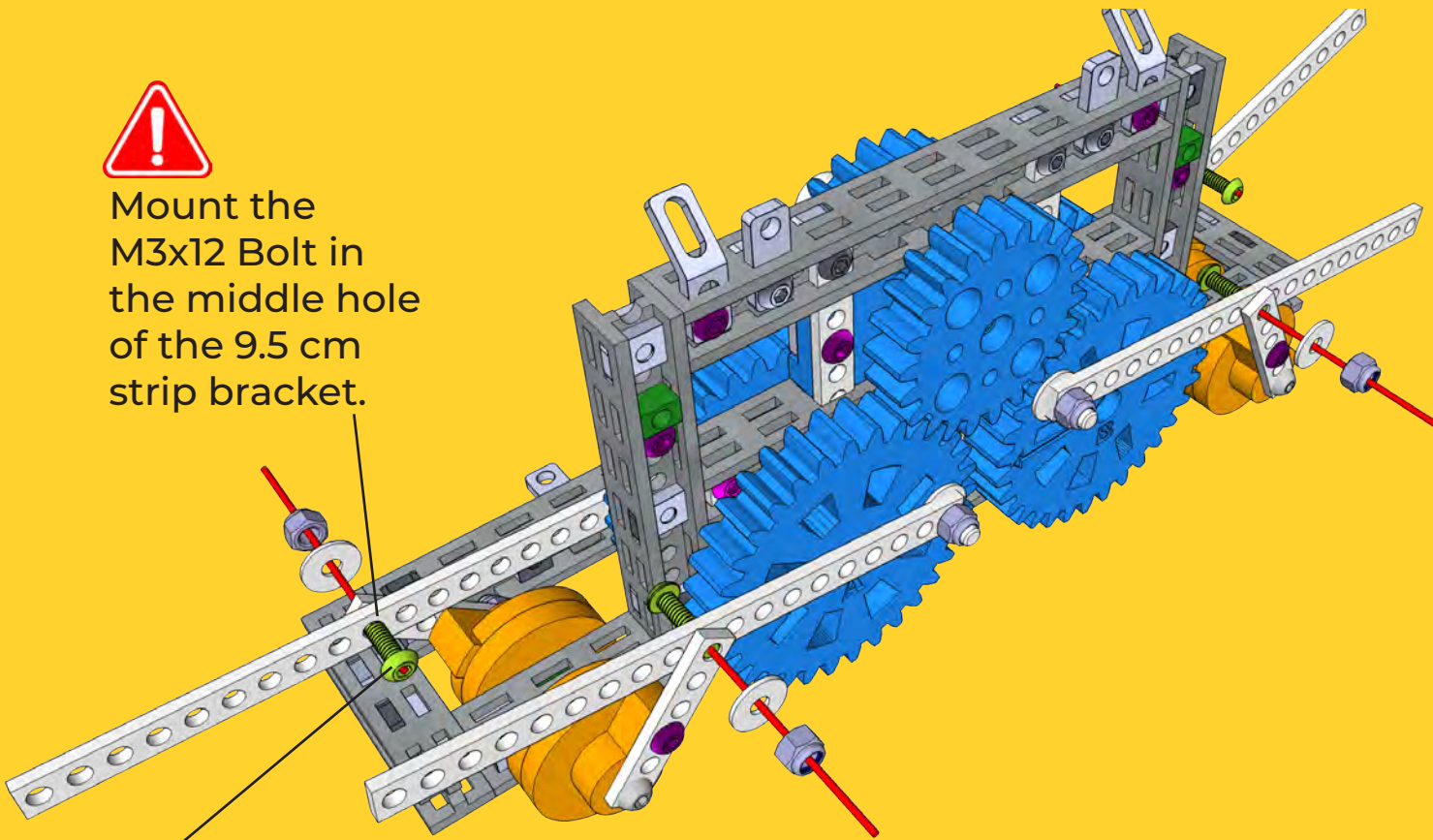

Mount the M3x12 Bolt in the middle hole of the 9.5 cm strip bracket.



- 8x

Lock Nut M3
- 8x

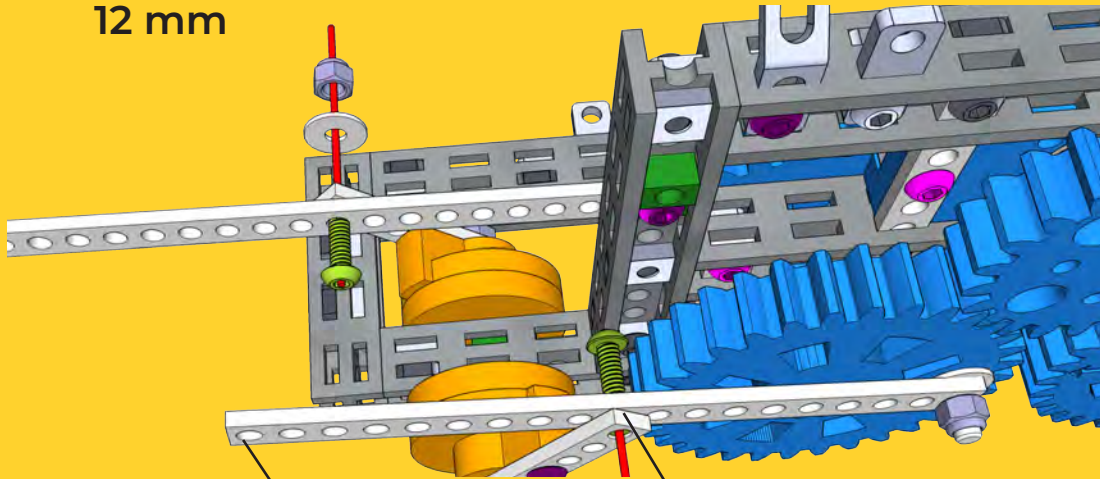
Washer 9/0.8mm M3
- 8x

M3x12 mm Bolt

12 mm

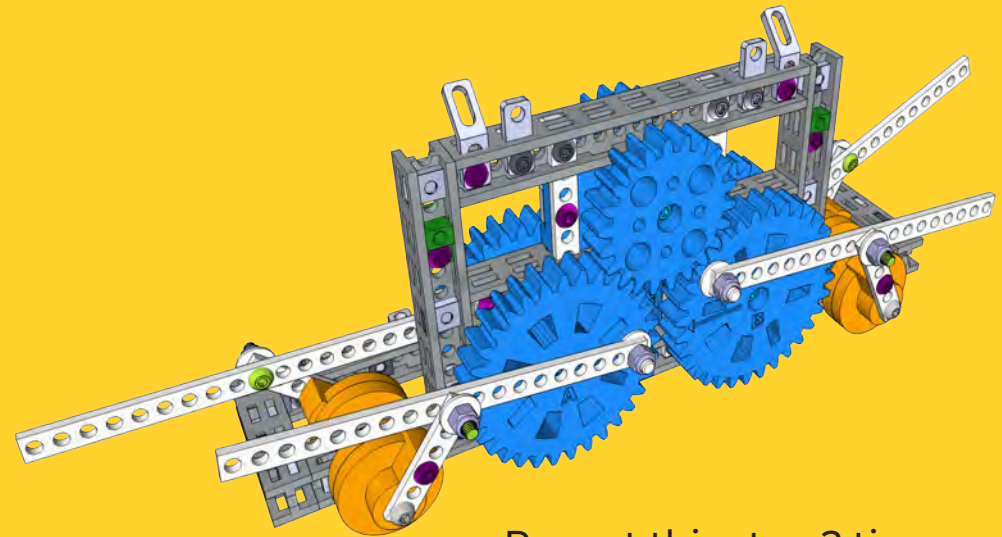

Hole #1

Hole #10



Repeat this step 2 times.

2x

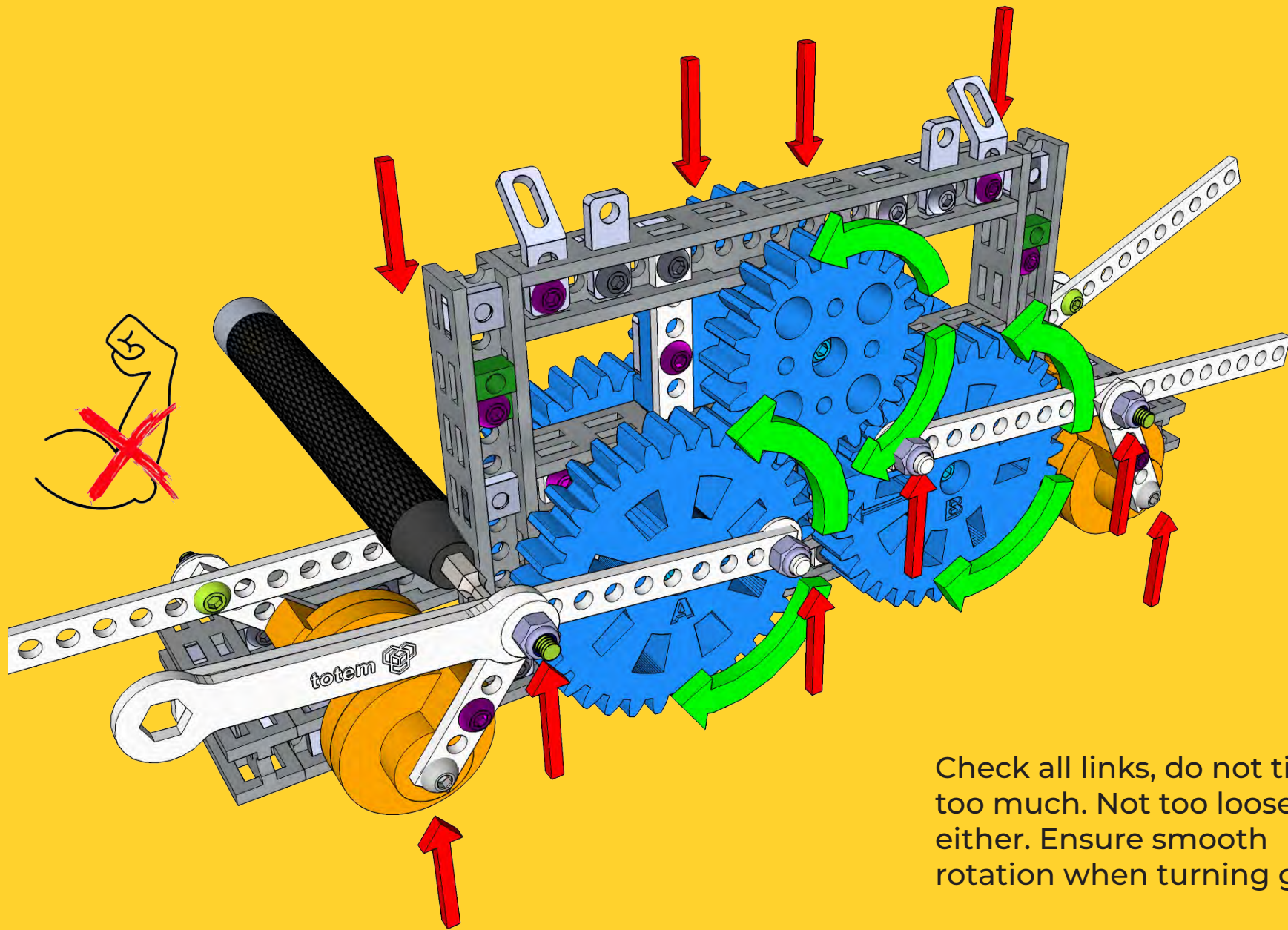

Check all links, do not tighten too much. Not too loose either. Ensure smooth rotation when turning gears.

PART 3



PART 4

4 x Part 1A

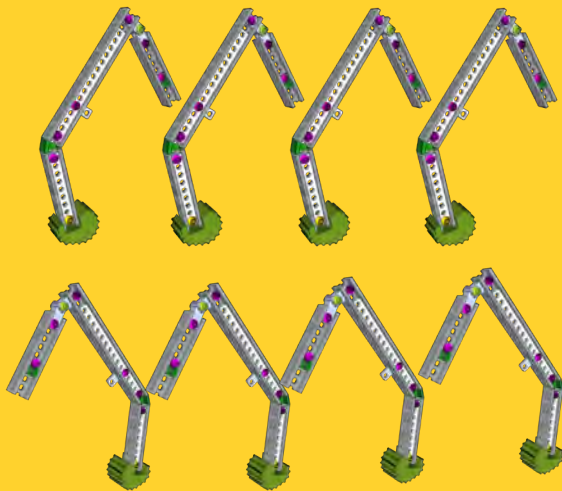

4 x Part 1B



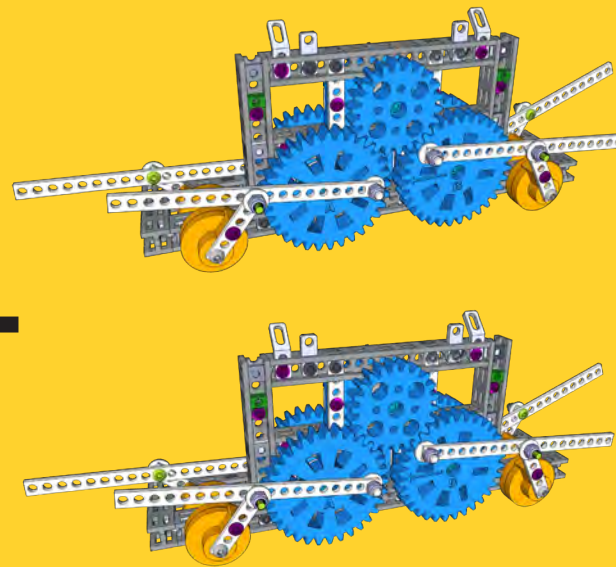

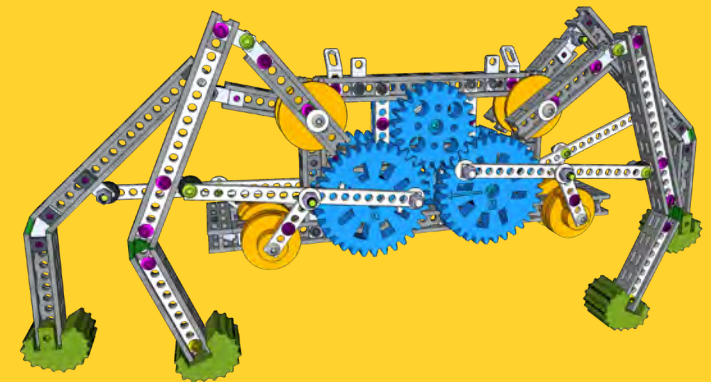

+



=

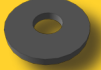

2 x Part 4

8x	4x	12x	8x	16x	8x
					
M3x12 mm Bolt	M3x45 mm Bolt	Lock Nut M3	Upper Arm Washer	Nylon Washer 8/1 mm M3	Washer 9/0.8mm M3

Part 1B

Part 1A

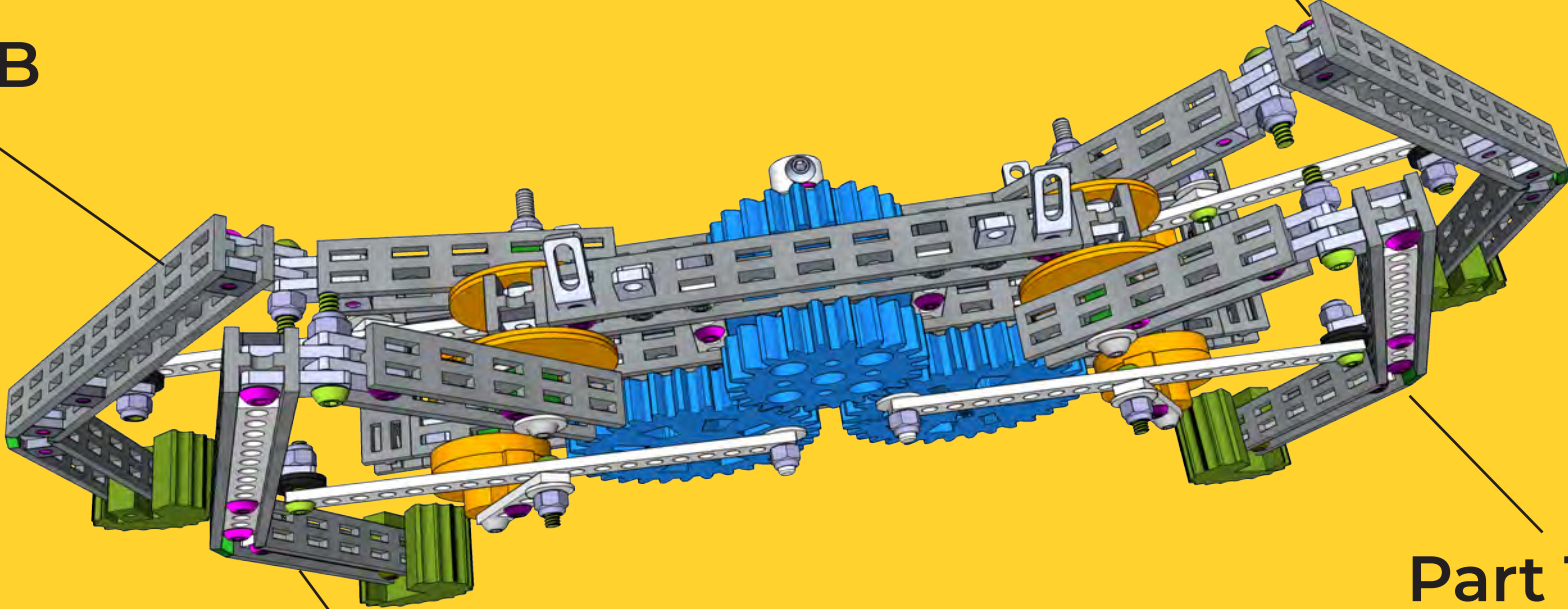

Part 1B

Part 1A

1

Part 1B

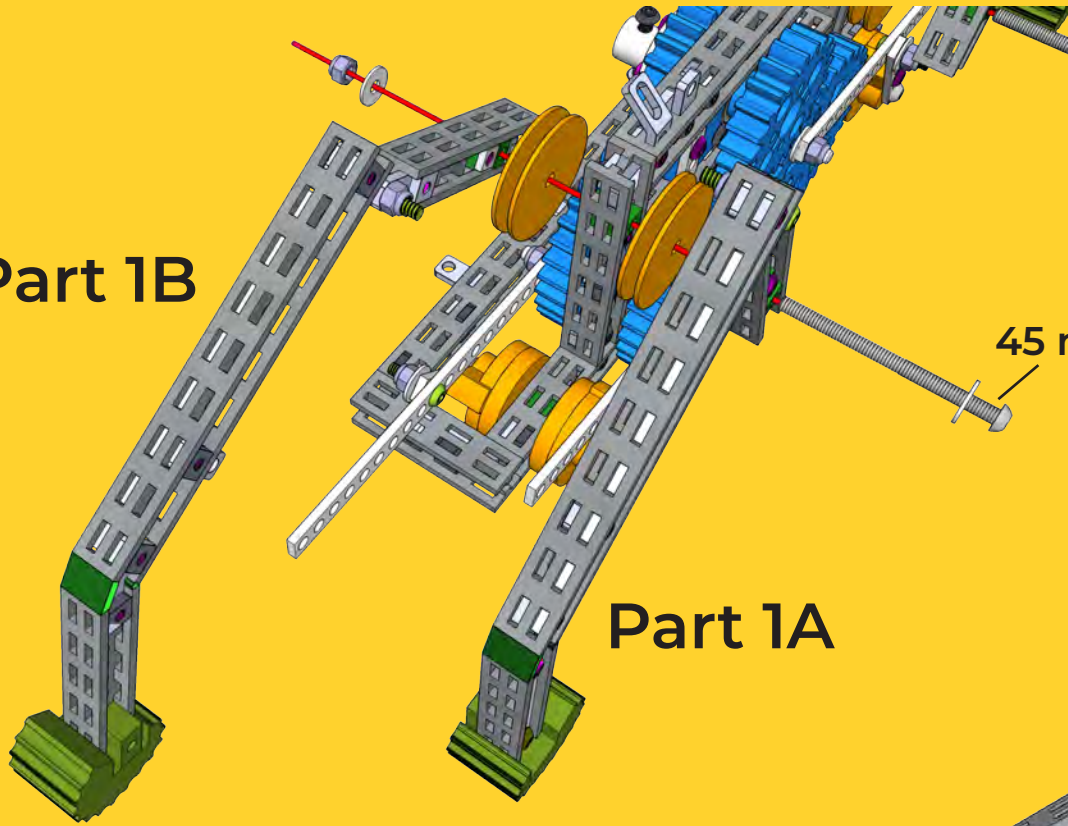

45 mm

Part 1A

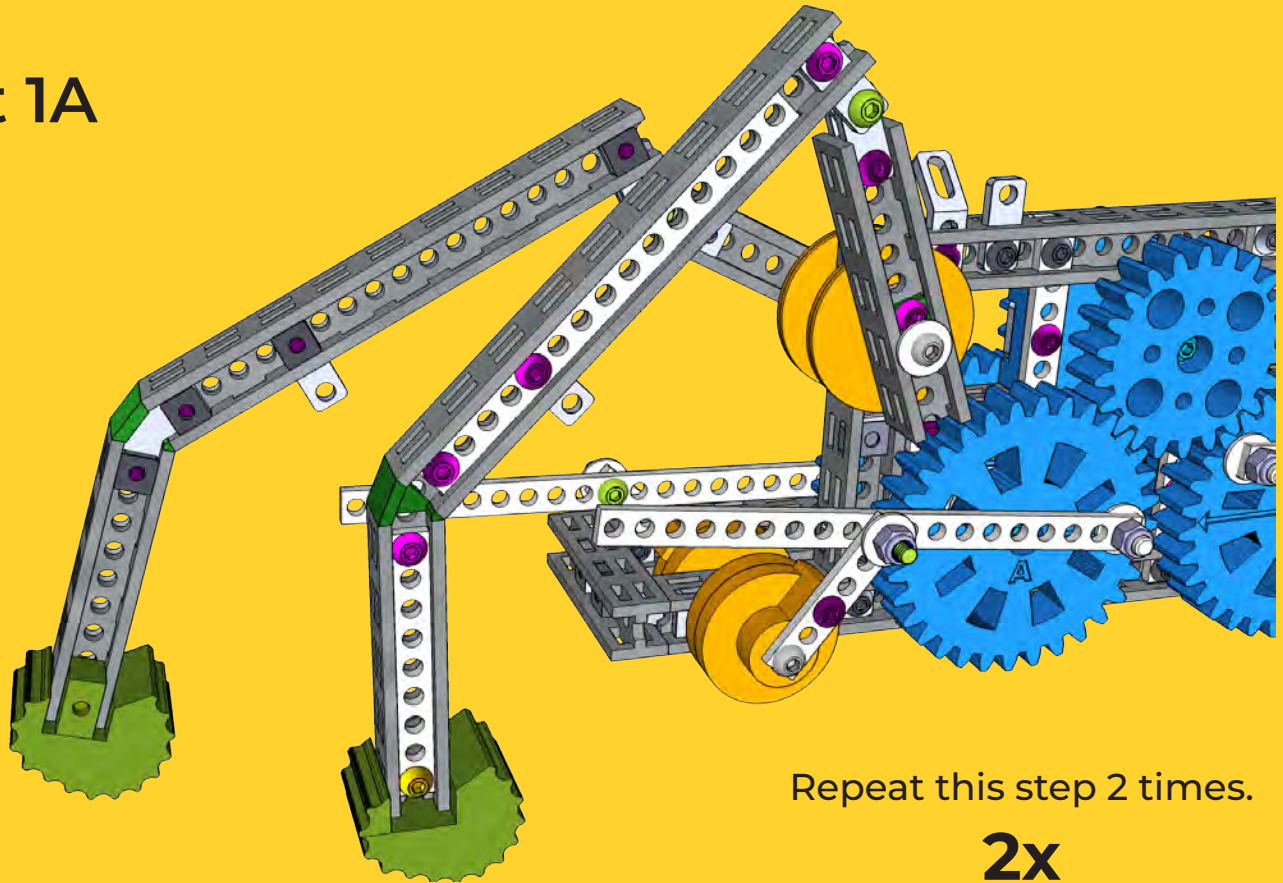

2x



Lock Nut M3

2x



M3x45 mm Bolt

4x



Upper Arm Washer

4x



Washer 9/0.8mm M3

Repeat this step 2 times.

2x

2

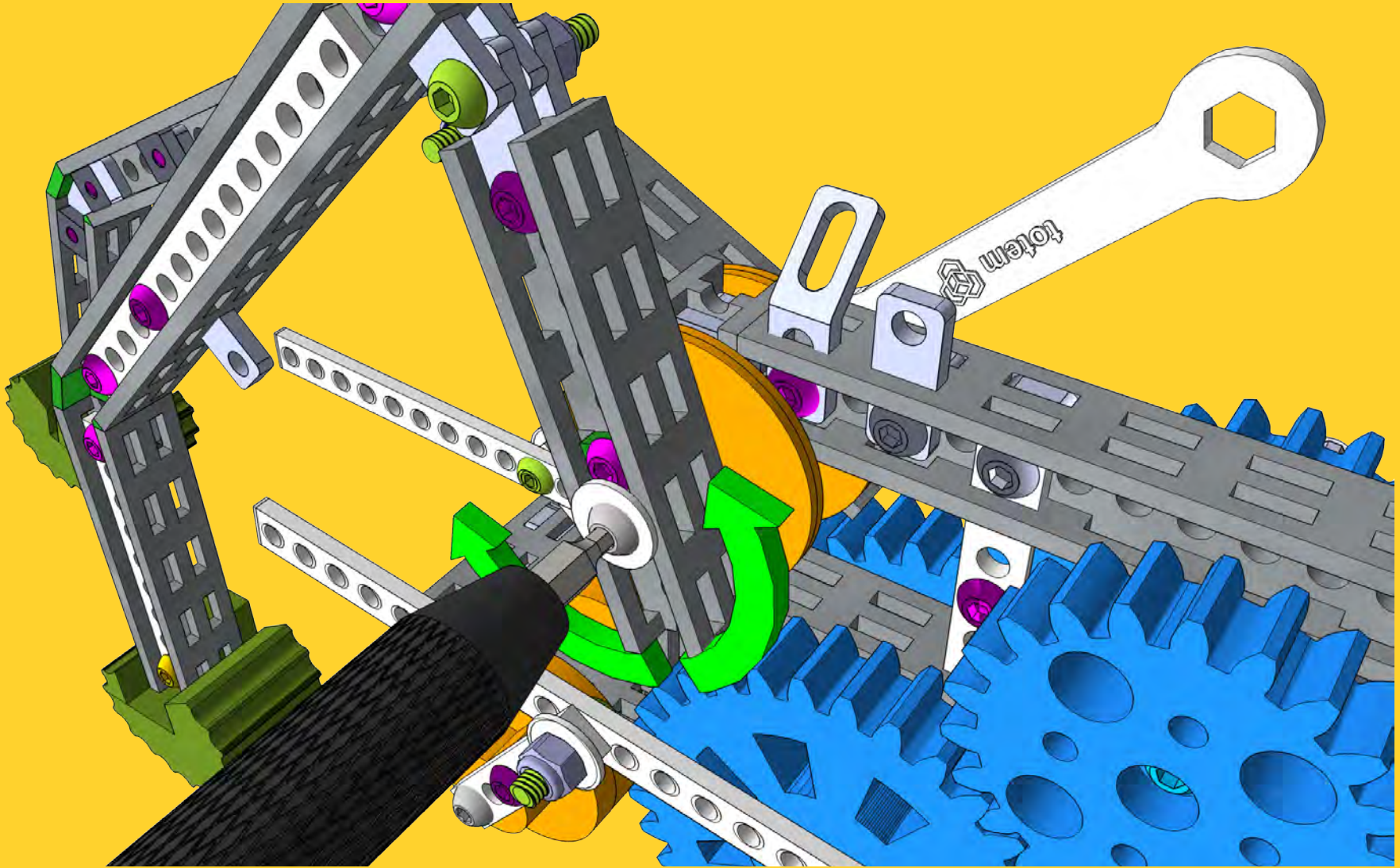

Do not overtighten.



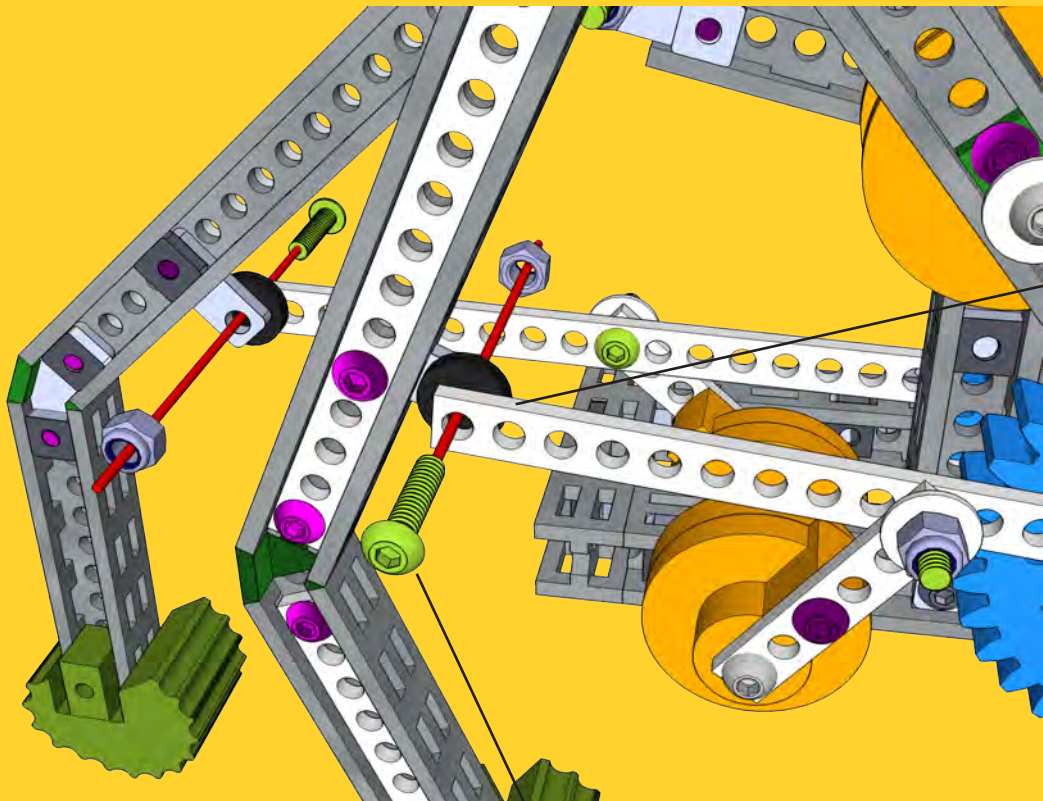

12 mm

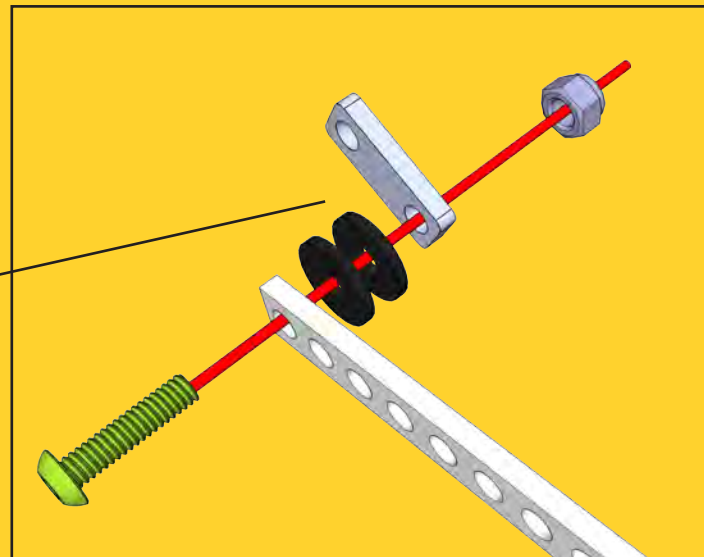

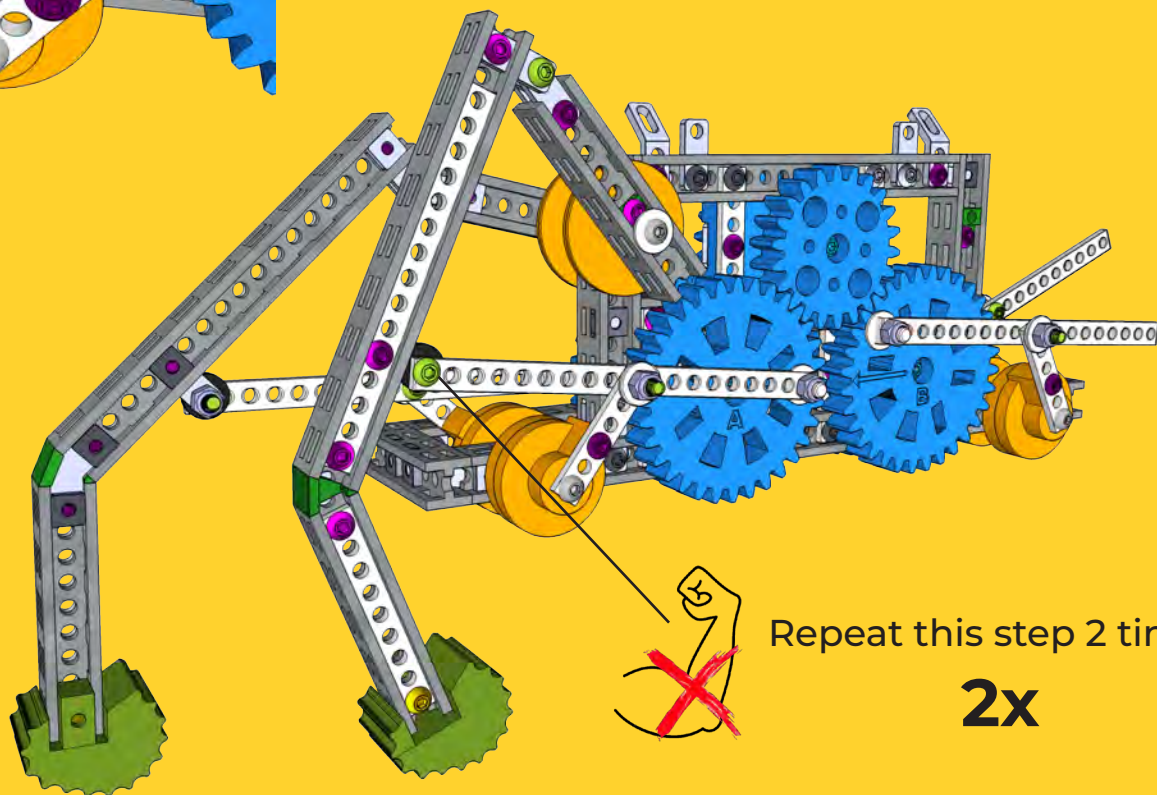

3



Repeat this step 2 times.





2x

- 4x

- M3x12 mm Bolt
- 4x

- Lock Nut M3
- 8x

- Nylon Washer 8/1 mm M3

Part 1A

Part 1B

- 2x

Lock Nut M3
- 2x

M3x45 mm Bolt
- 4x

Upper Arm Washer
- 4x

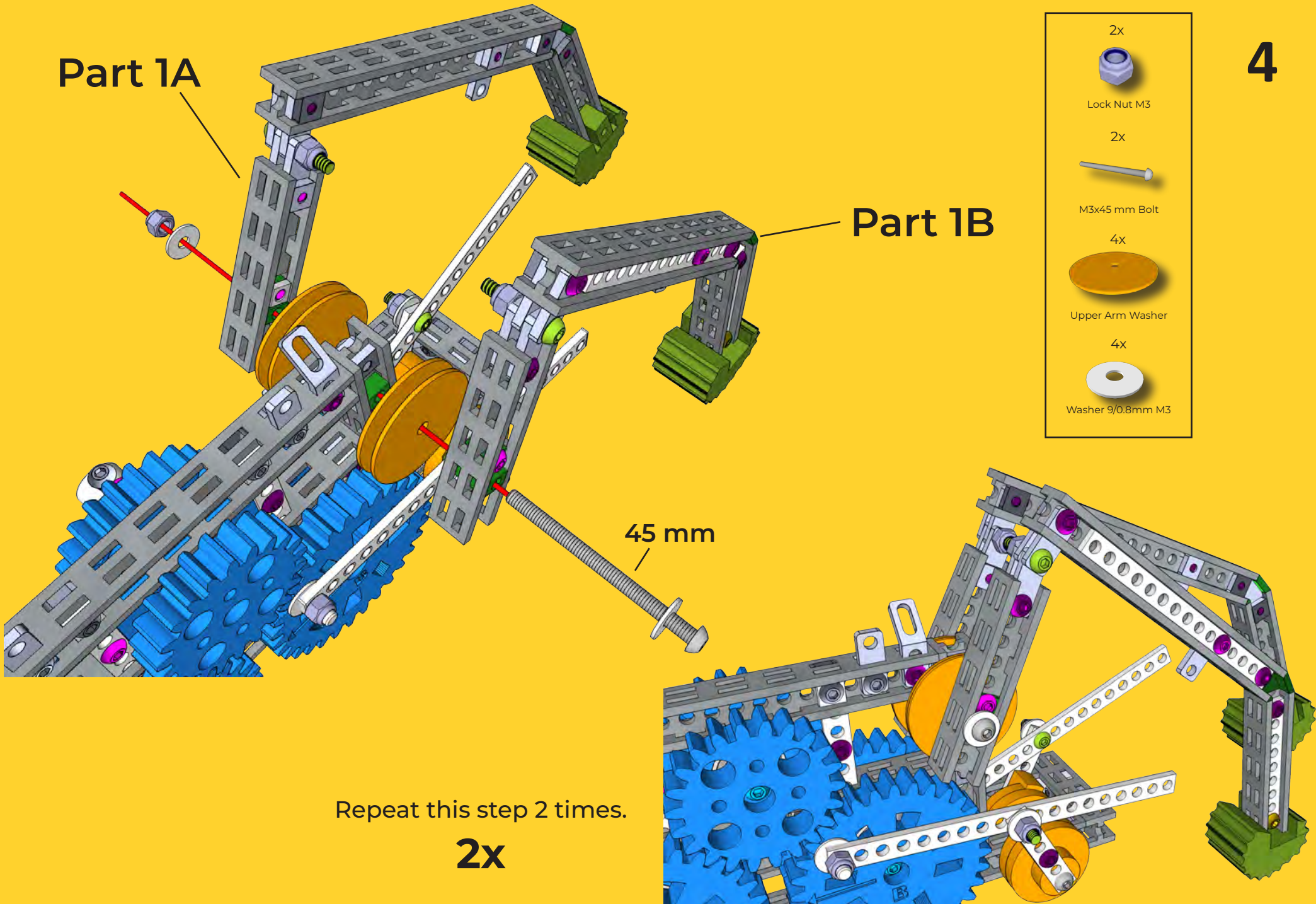
Washer 9/0.8mm M3

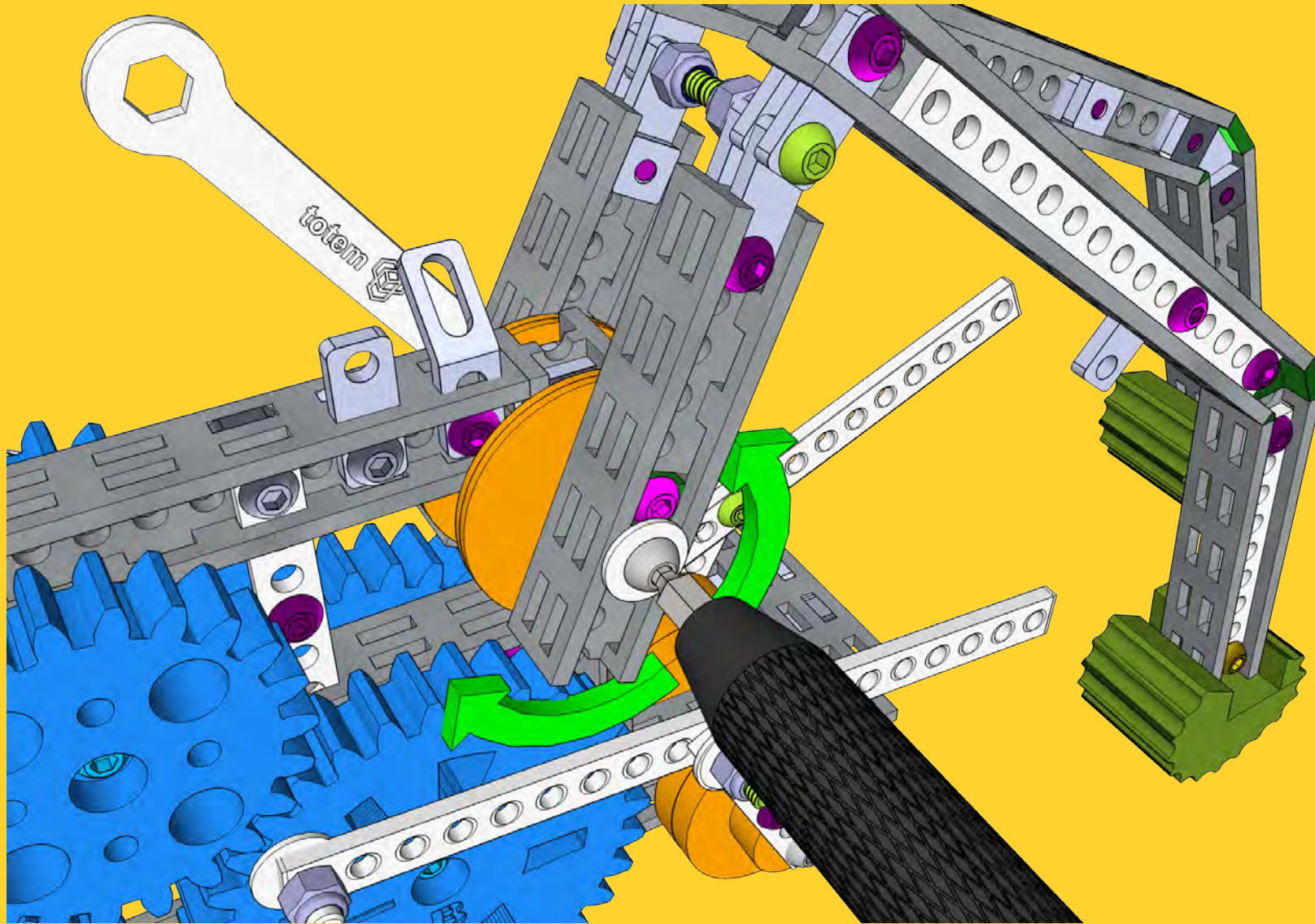
45 mm

Repeat this step 2 times.

2x





Do not overtighten.



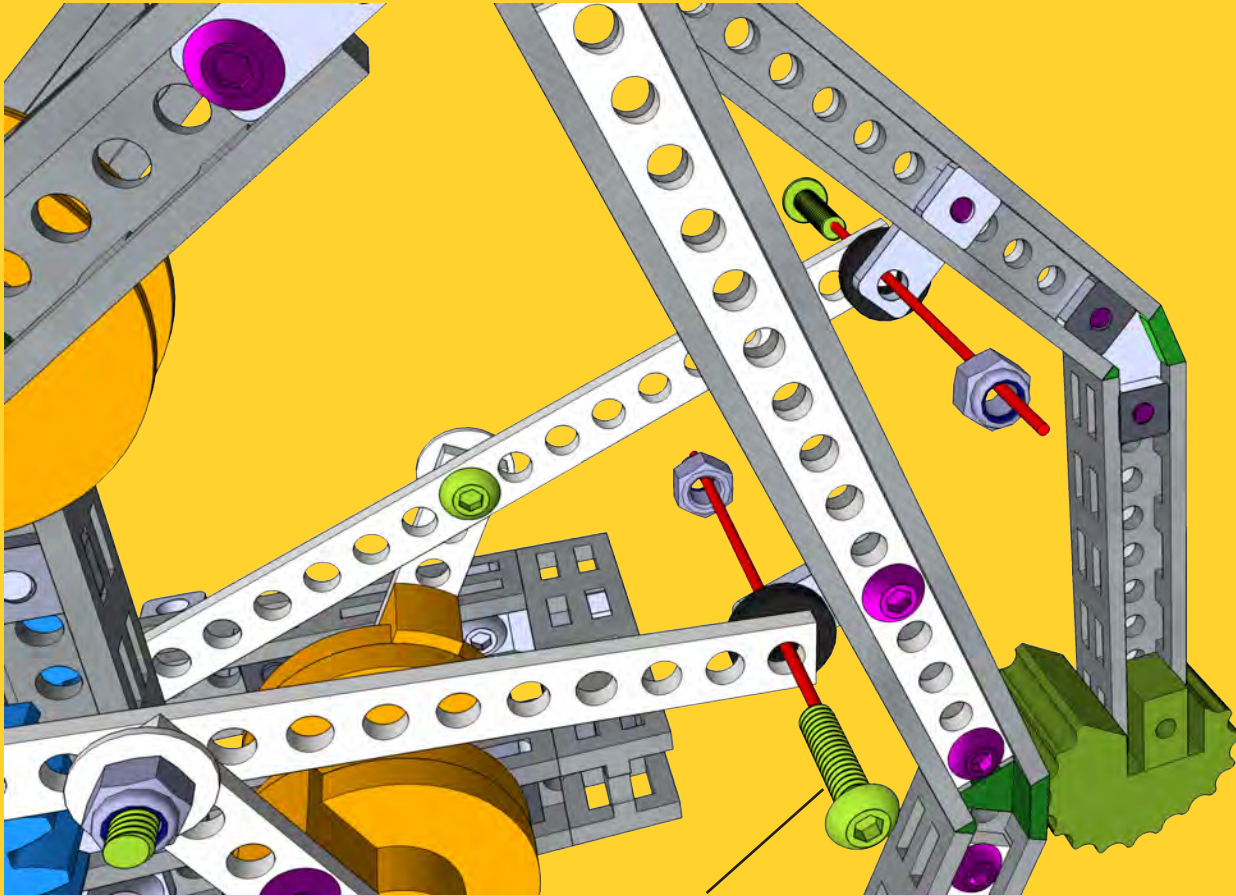

- 4x

M3x12 mm Bolt
- 4x

Lock Nut M3
- 8x

Nylon Washer 8/1 mm M3

12 mm

Do not overtighten.



Repeat this step 2 times.

2x

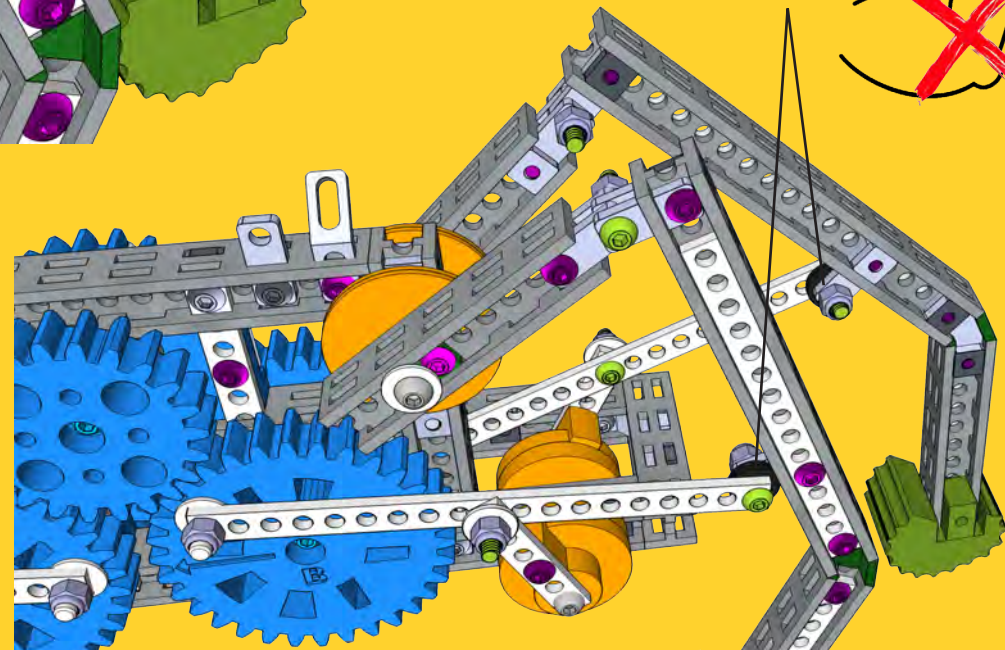

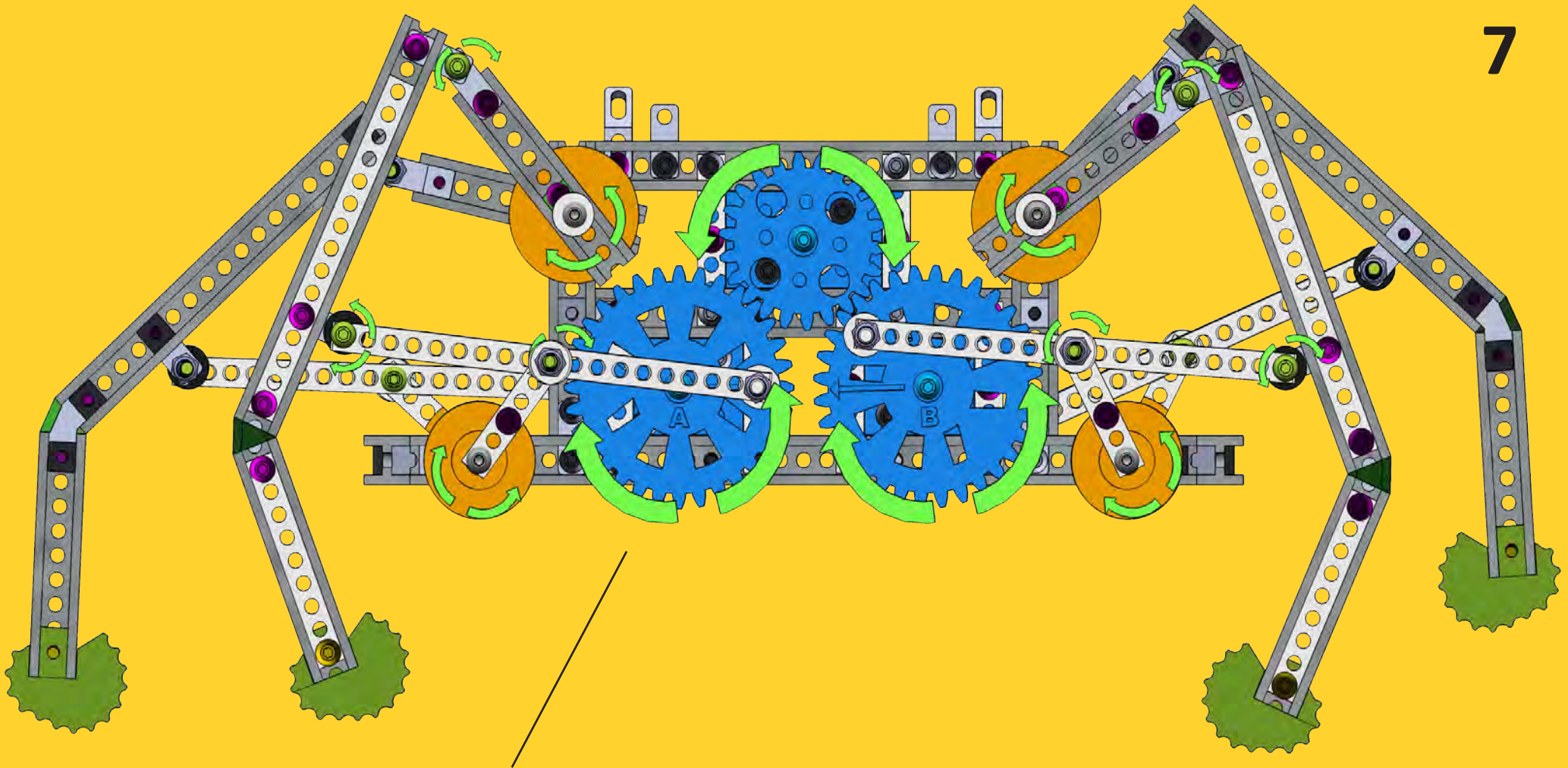

Try spinning the gears with your hands, and check if it has a smooth motion. Legs and links should not be too wobbly.

PART 4



PART 5

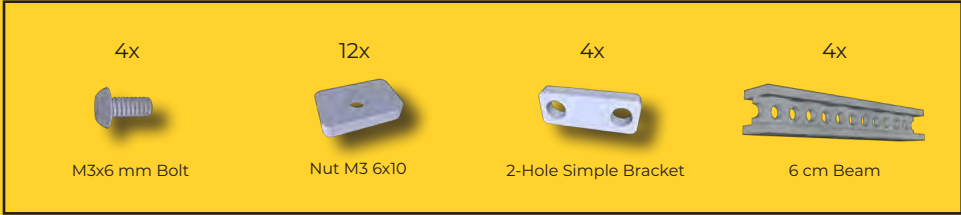
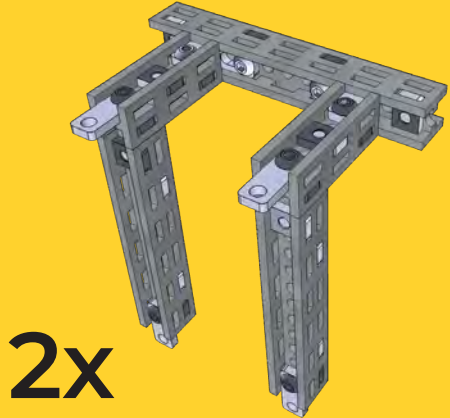

1

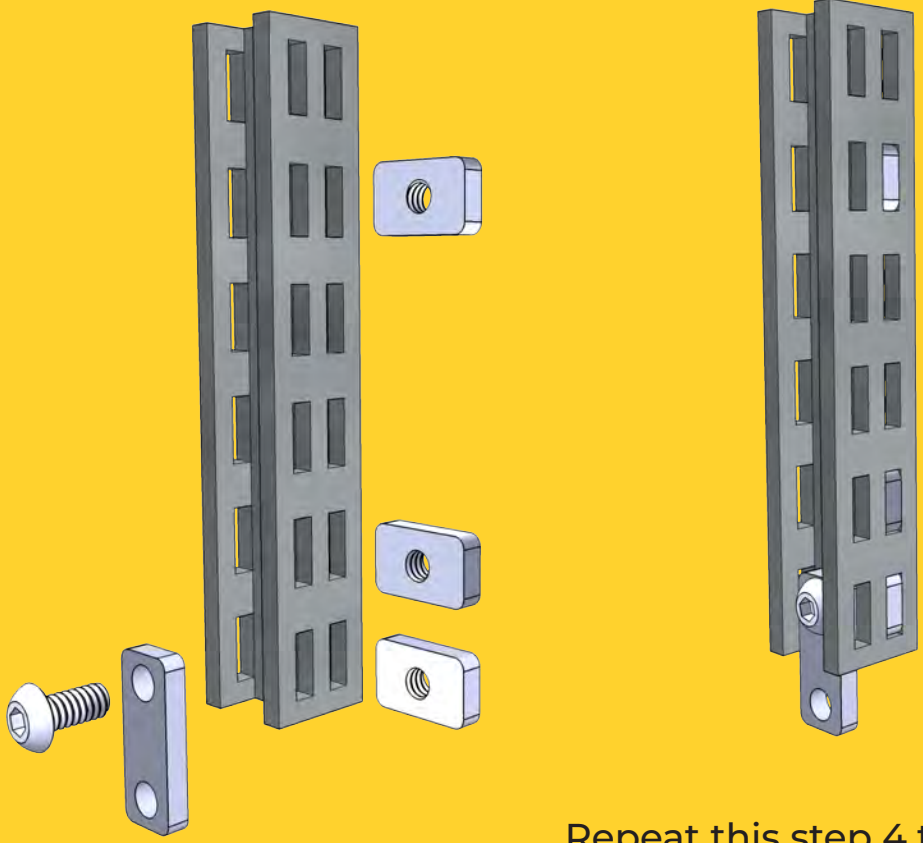



Repeat this step 4 times.

4x

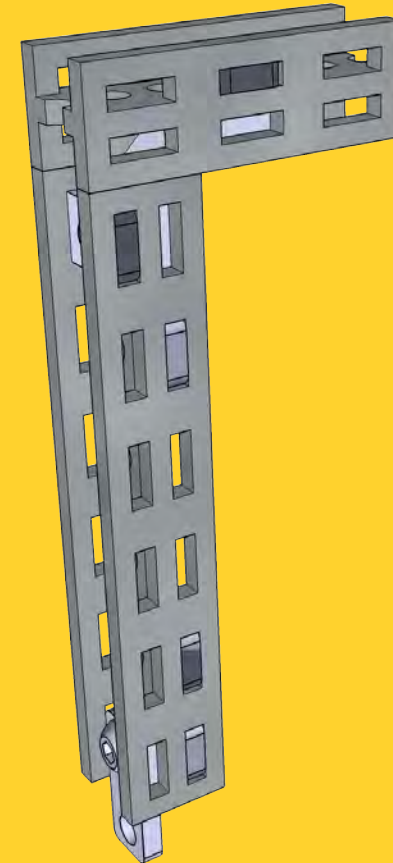
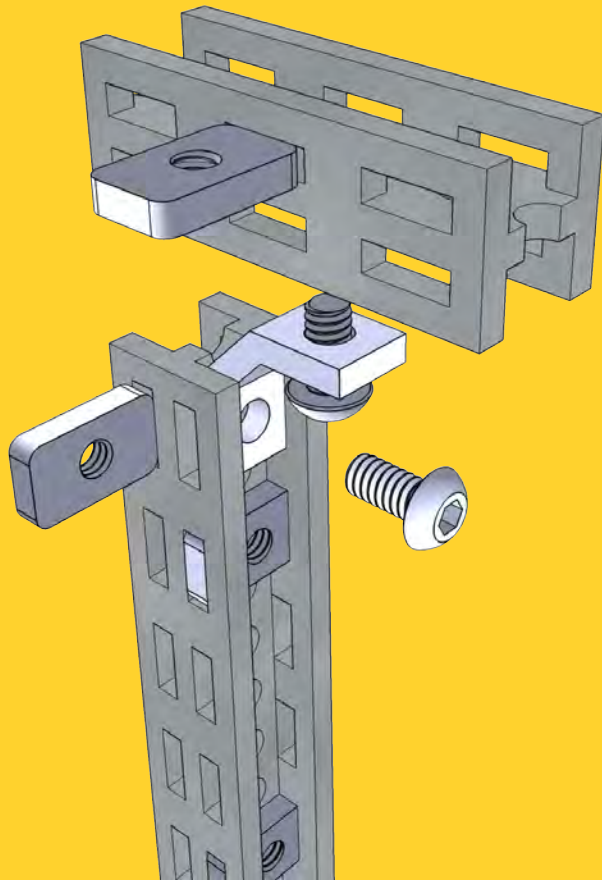
2



8x	8x	4x	4x
			
M3x6 mm Bolt	Nut M3 6x10	C-Bracket	3 cm Beam

Repeat this step 4 times.

4x

3

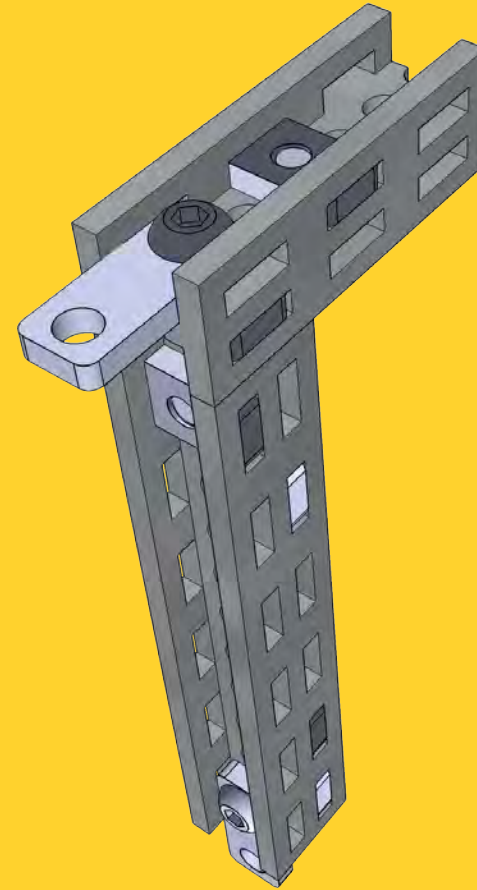
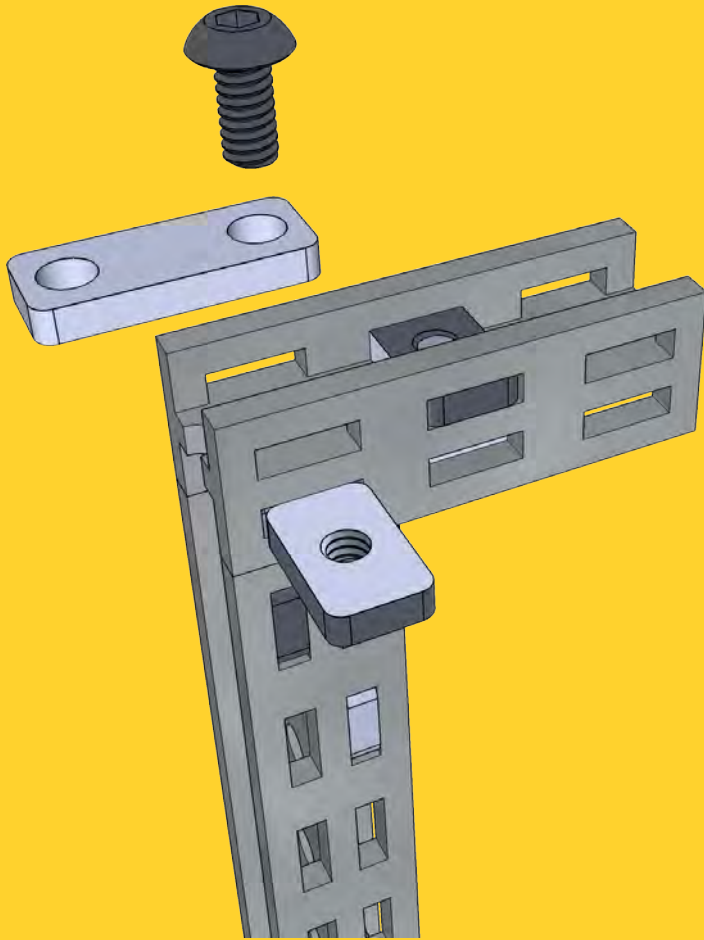

4x	4x	4x
		
M3x6 mm Bolt	Nut M3 6x10	2-Hole Simple Bracket

Repeat this step 4 times.

4x

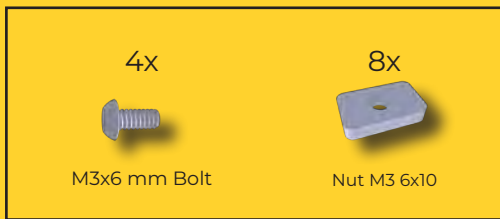
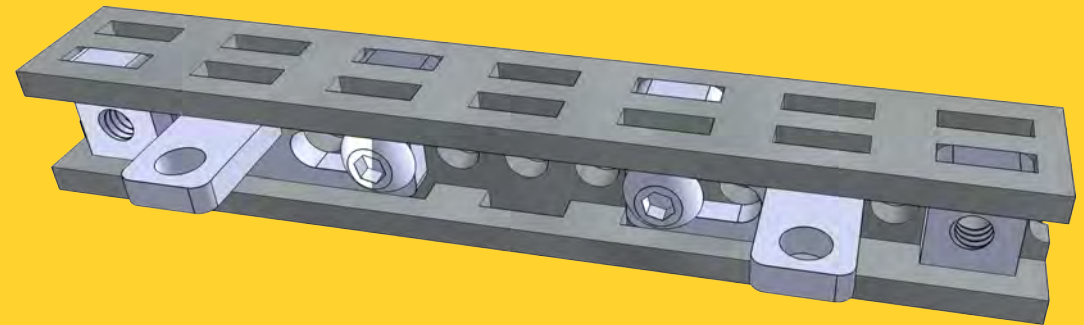
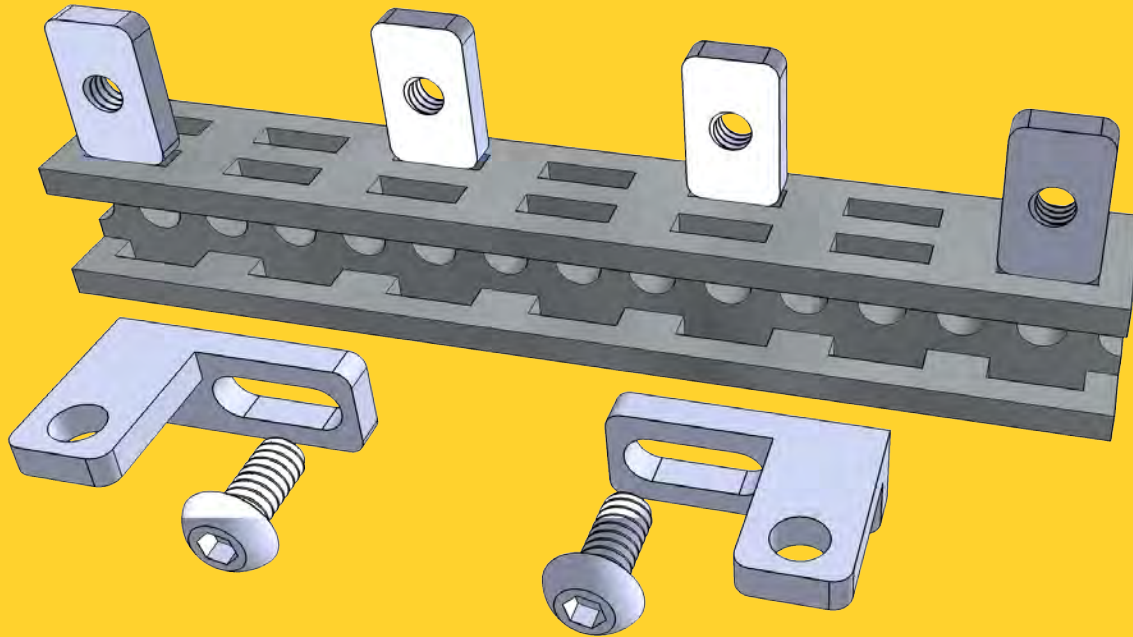

Repeat this step 2 times.

2x

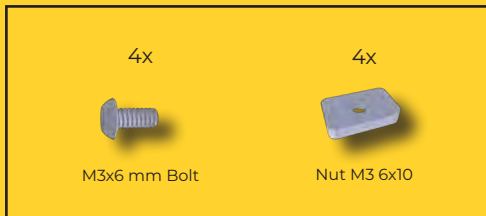
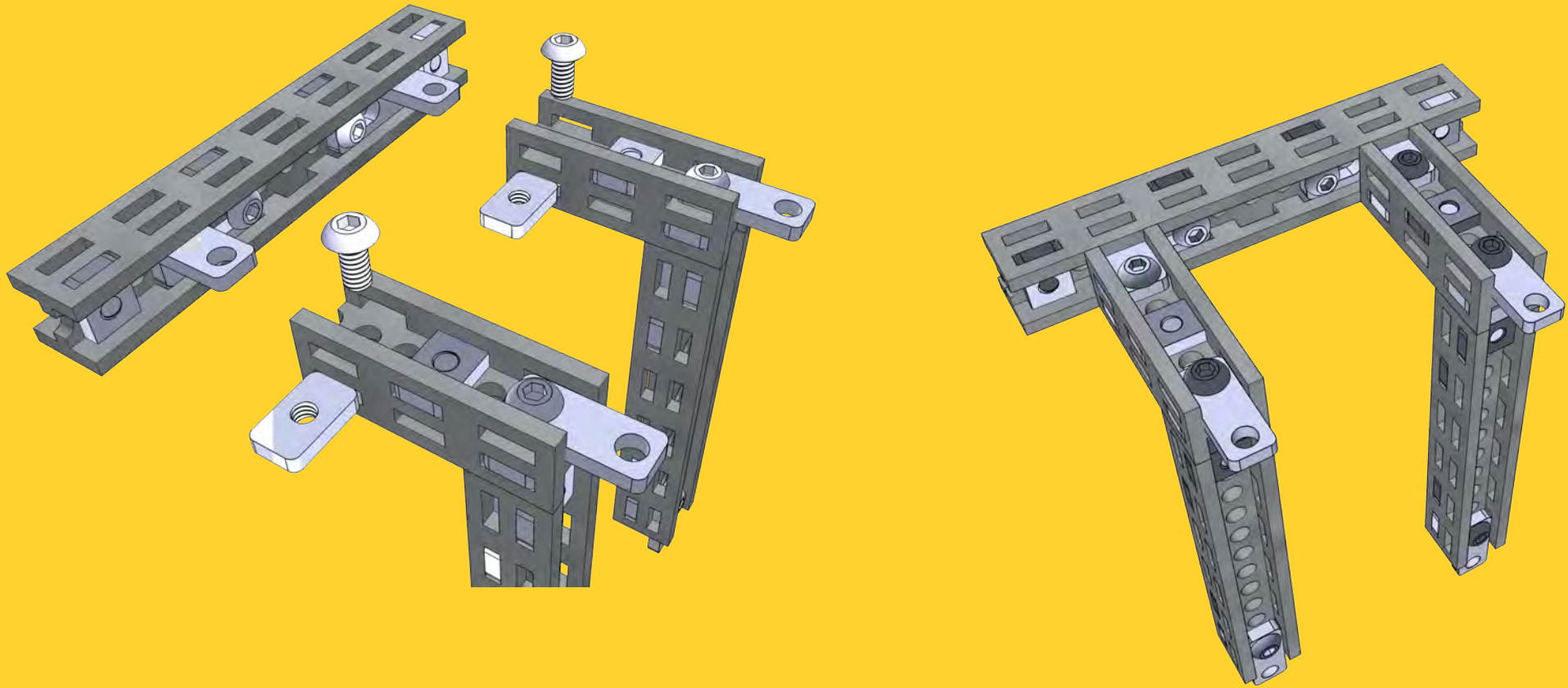

Repeat this step 2 times.

2x



PART 5

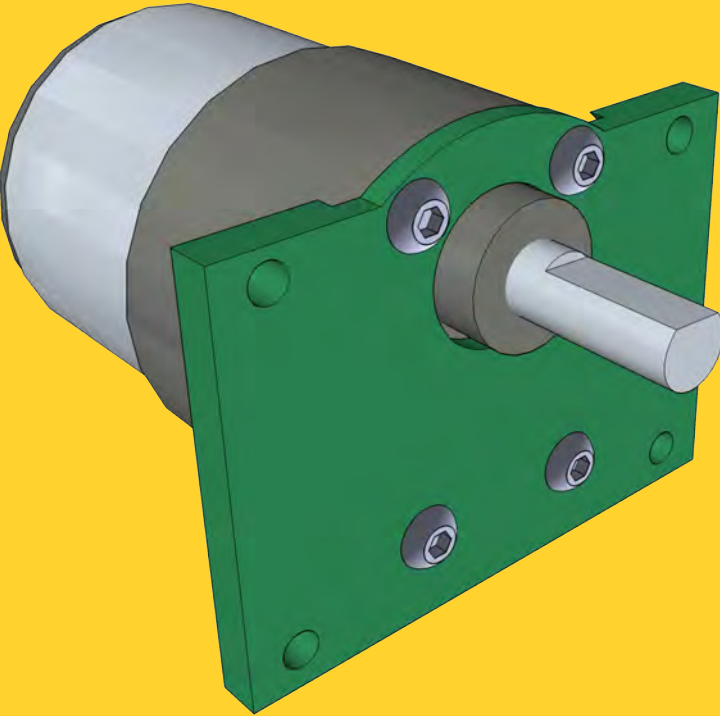
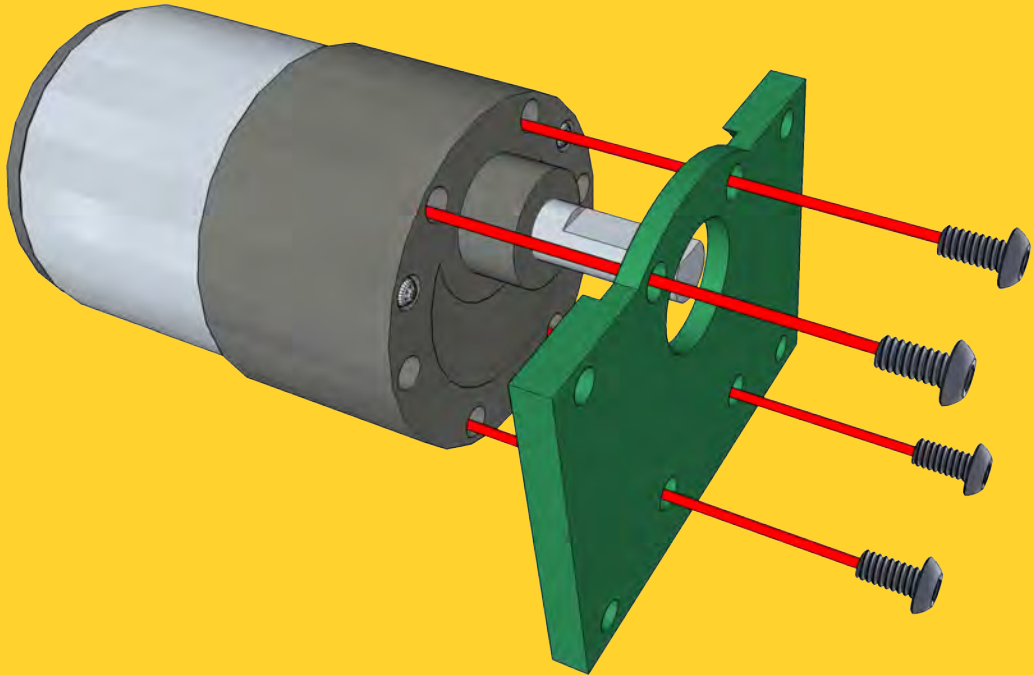

PART 6

1



8x	2x	2x
		
M3x6 mm Bolt	Motor-Plate 37 mm	37 mm DC Motor

Repeat this step 2 times.

2x

PART 7

12x
M3x6 mm Bolt

8x
M3x14 mm Bolt

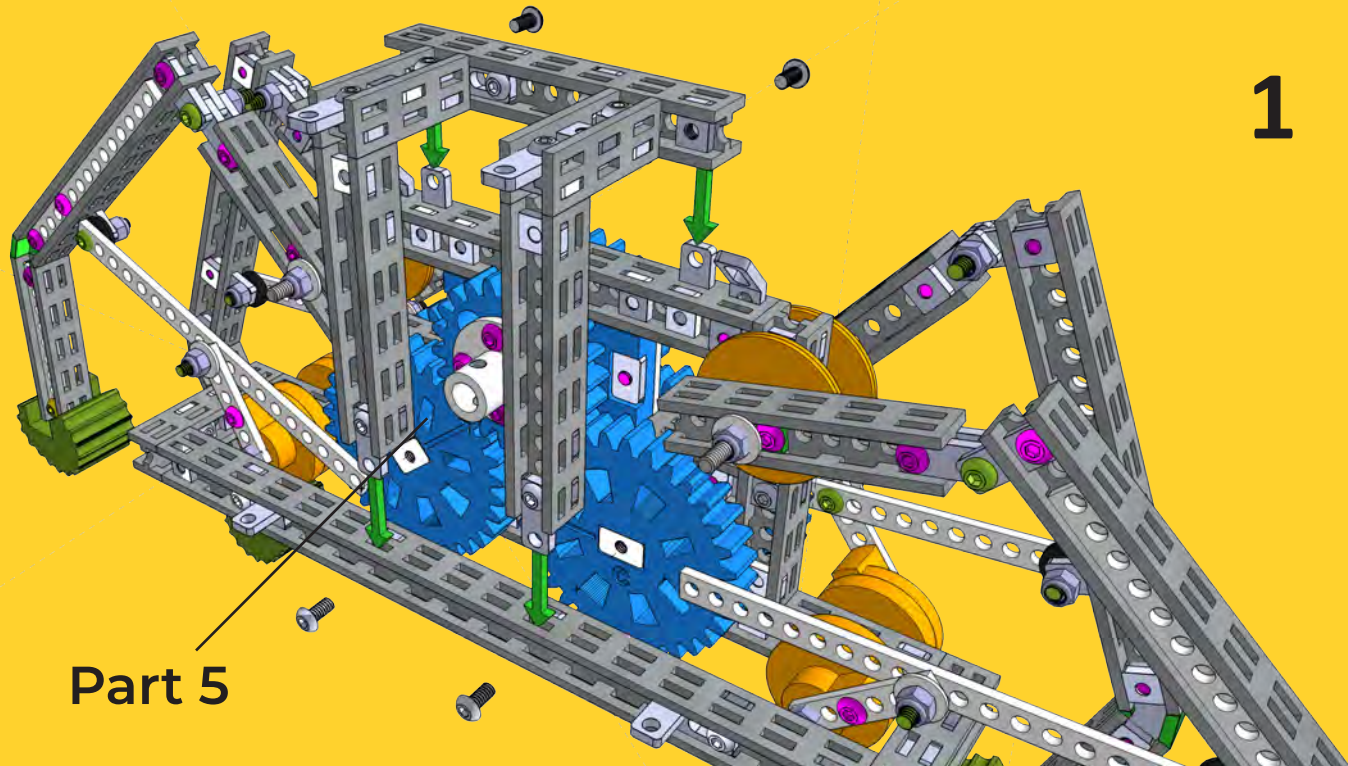
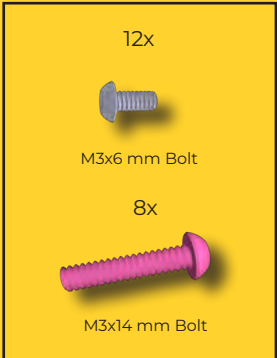

8x
M3x6 mm Bolt

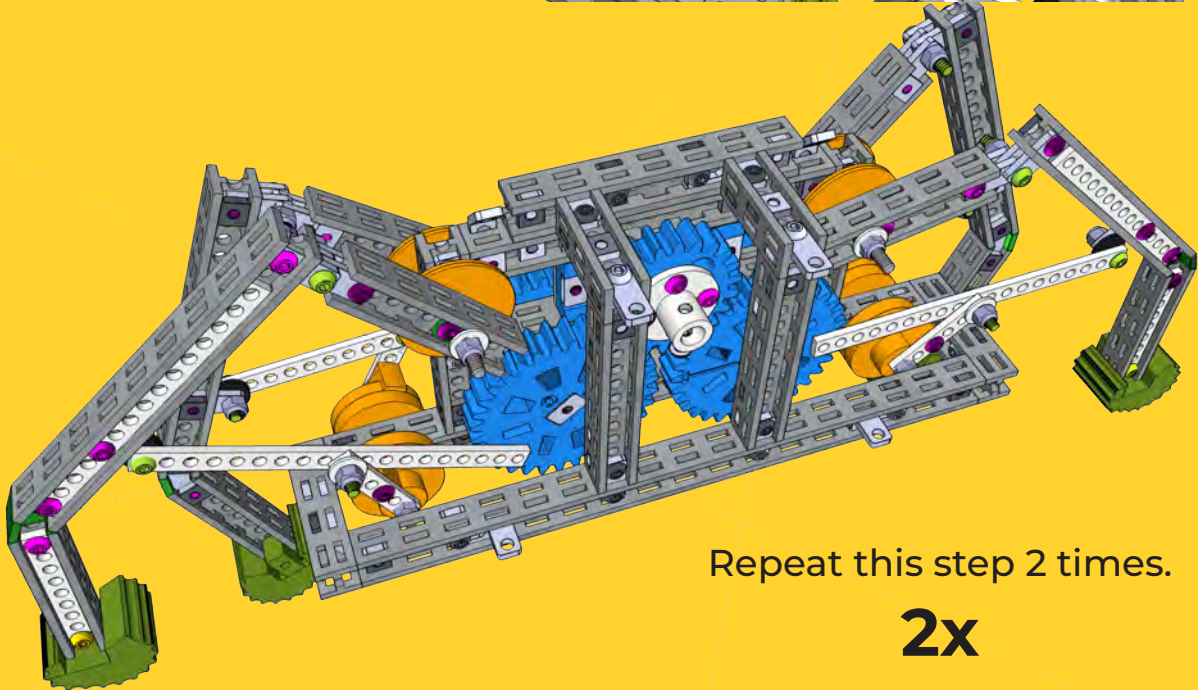
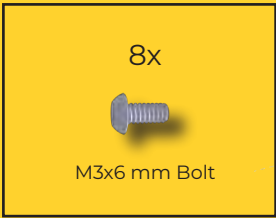

Repeat this step 2 times.

2x

2

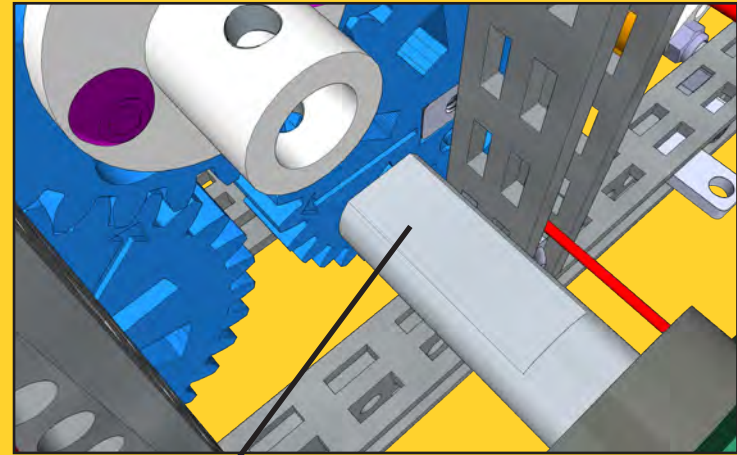
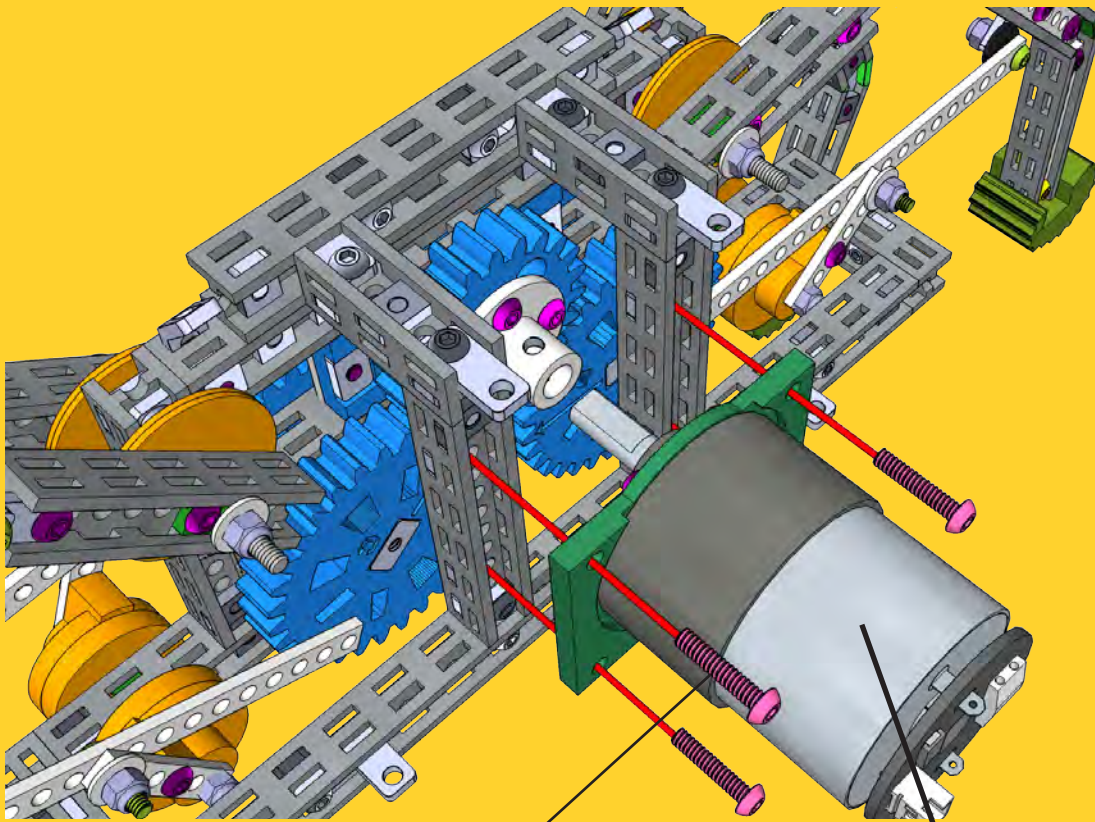

Flat side up

Part 6

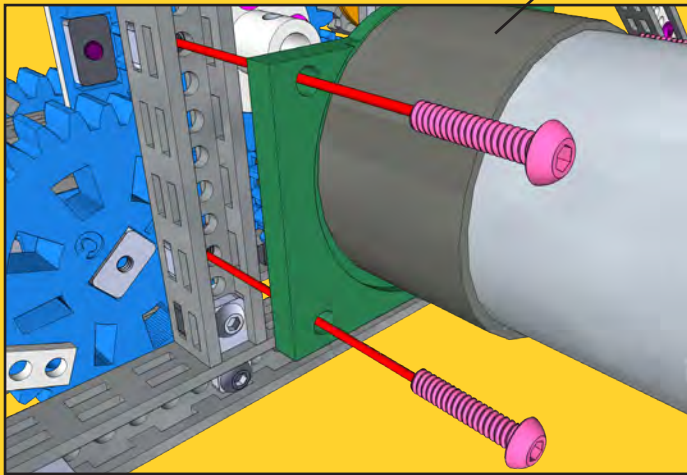

Repeat this step 2 times.

2x

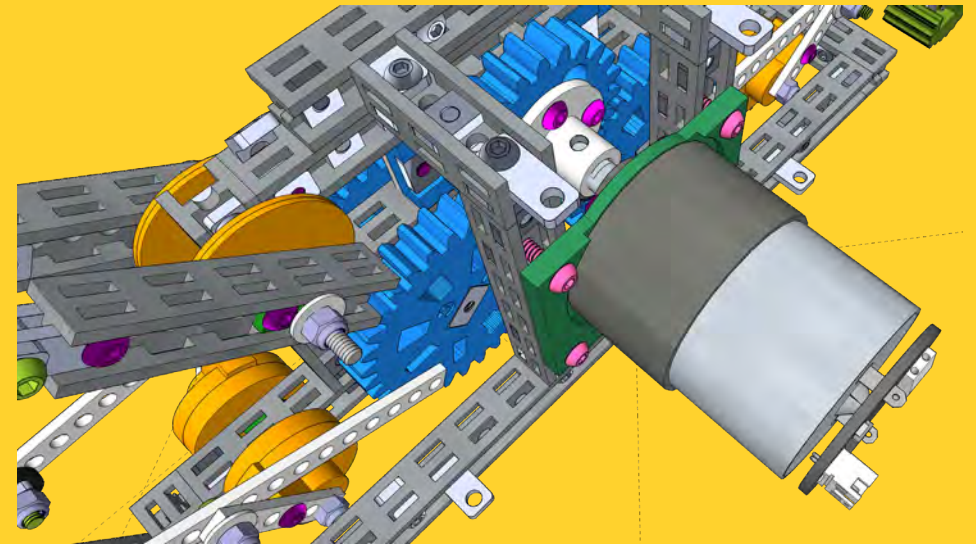
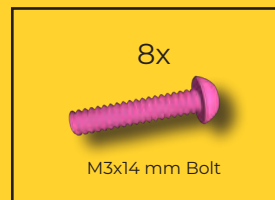

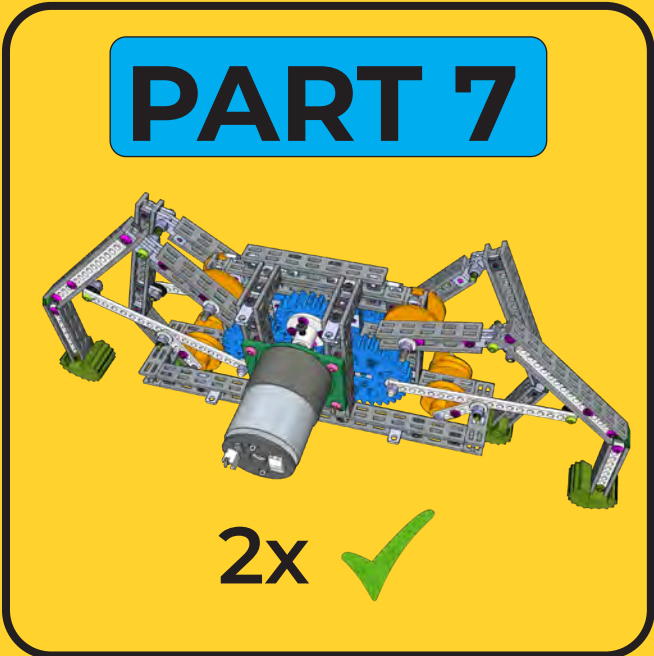
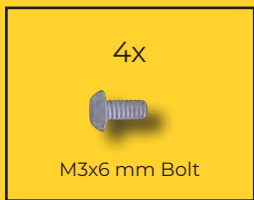
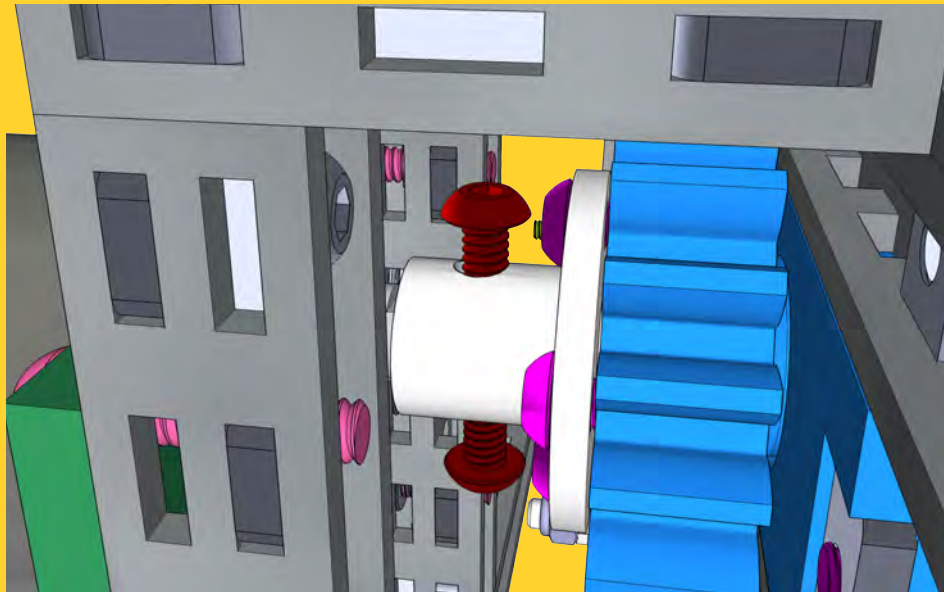
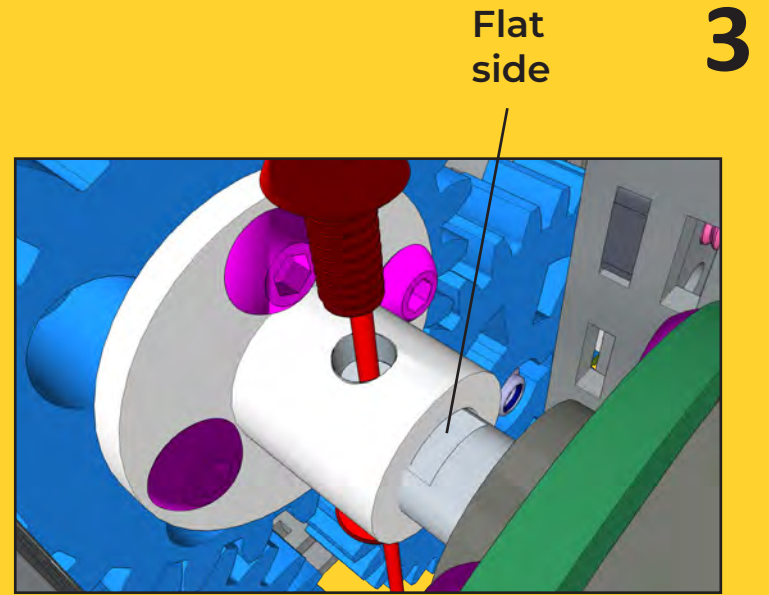
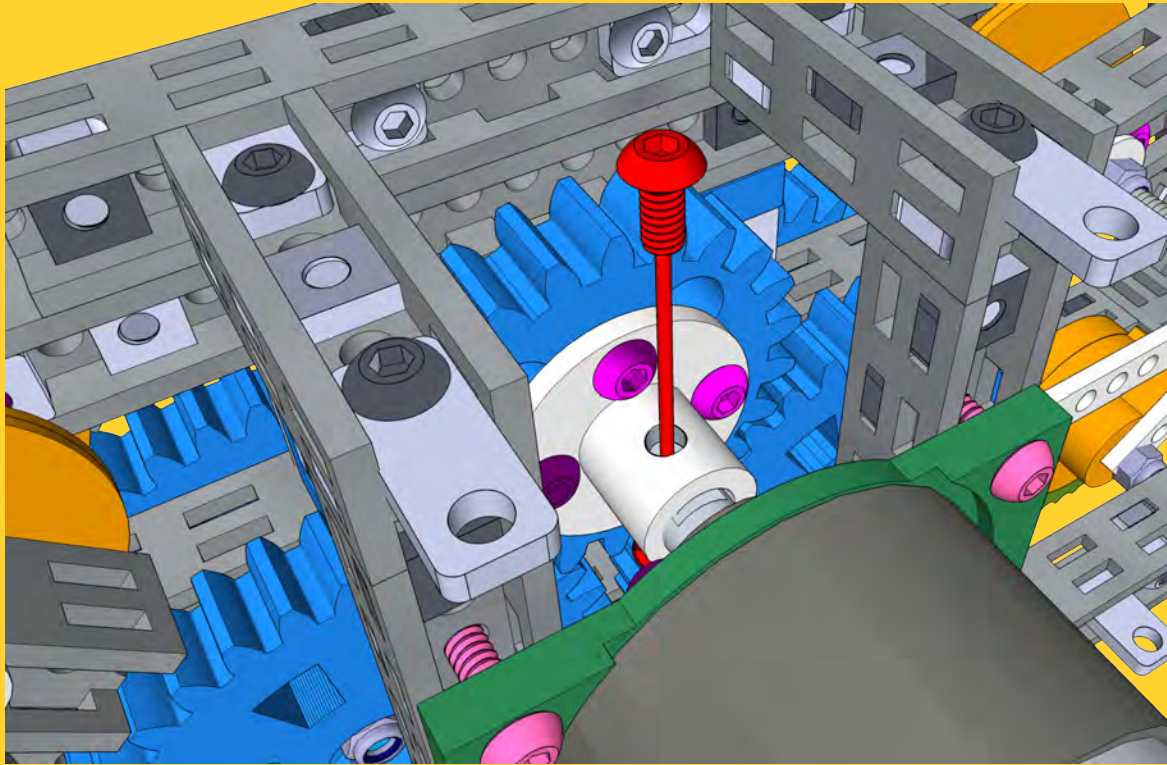

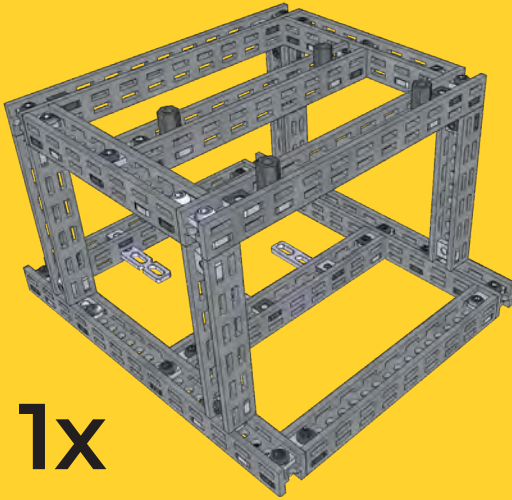

PART 8





1x

44x  M3x6mm Bolt	56x  Nut M3 6x10	12x  2-Hole Simple Bracket
---	---	---

4x  C-Bracket	4x  3-Hole Bracket	2x  L-Twisted Mirror Bracket
--	---	---



2x  L-Twisted Bracket	4x  Nylon Standoff M3x8 mm	4x  6 cm Beam
--	---	--

2x  7 cm Beam	4x  9 cm Beam	2x  11 cm Beam
--	--	---

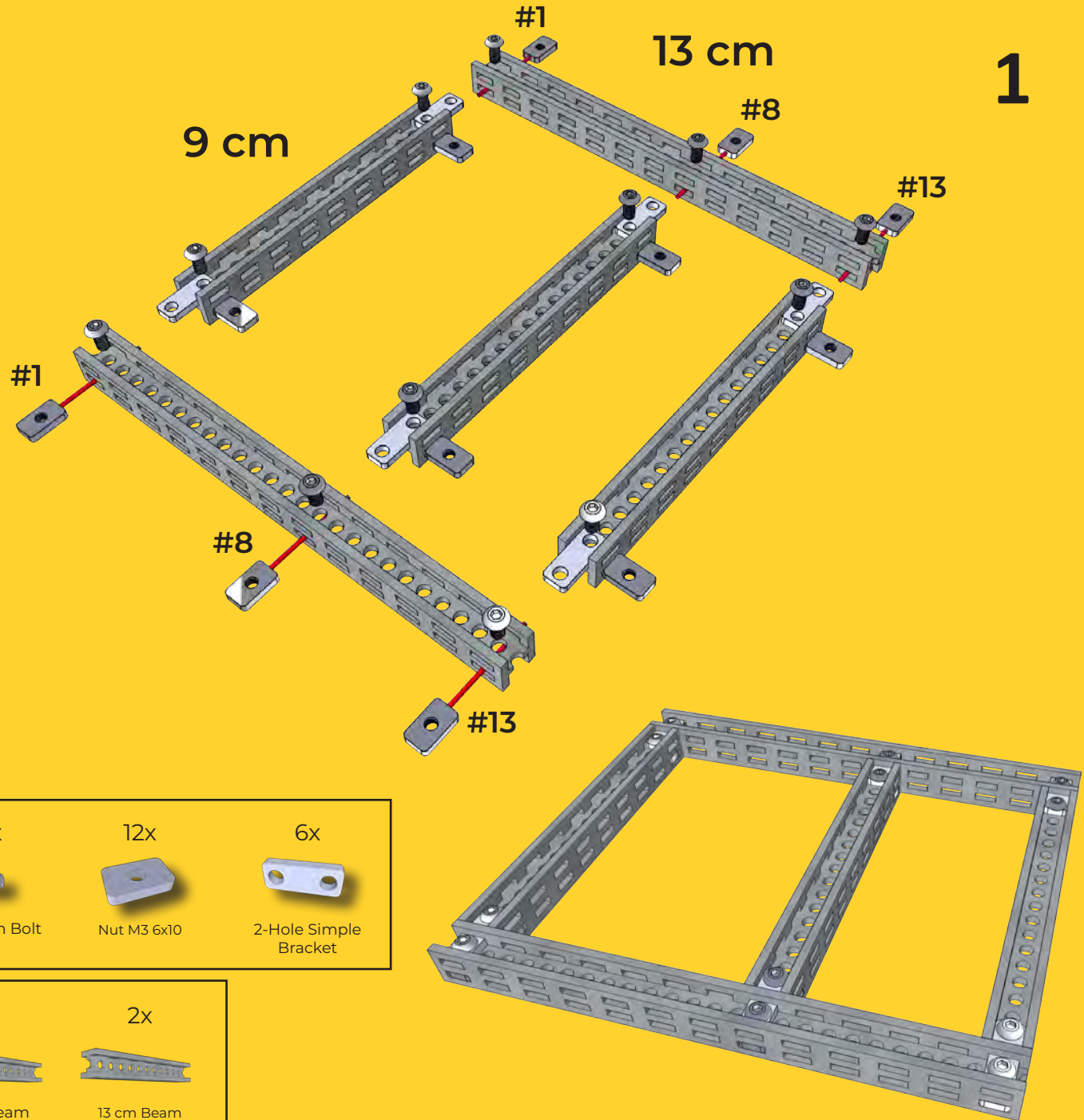
2x  13 cm Beam



12x  M3x6 mm Bolt	12x  Nut M3 6x10	6x  2-Hole Simple Bracket
--	--	--

3x  9 cm Beam	2x  13 cm Beam
--	--

2

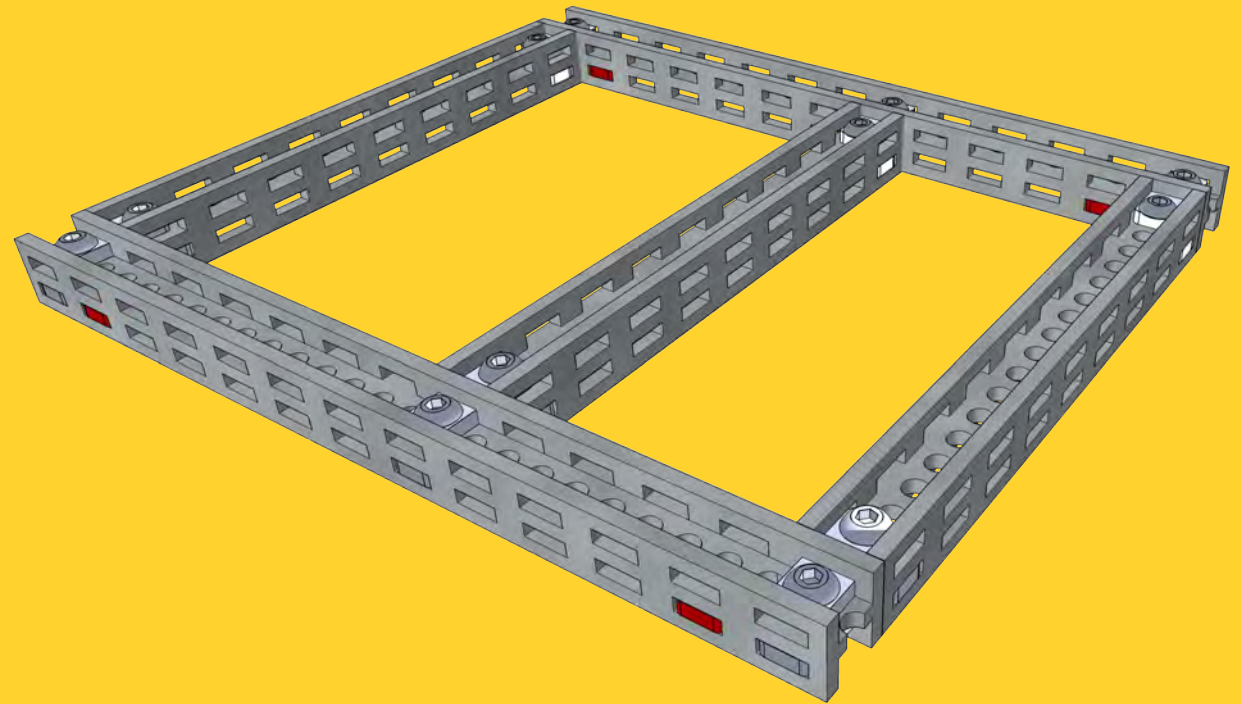
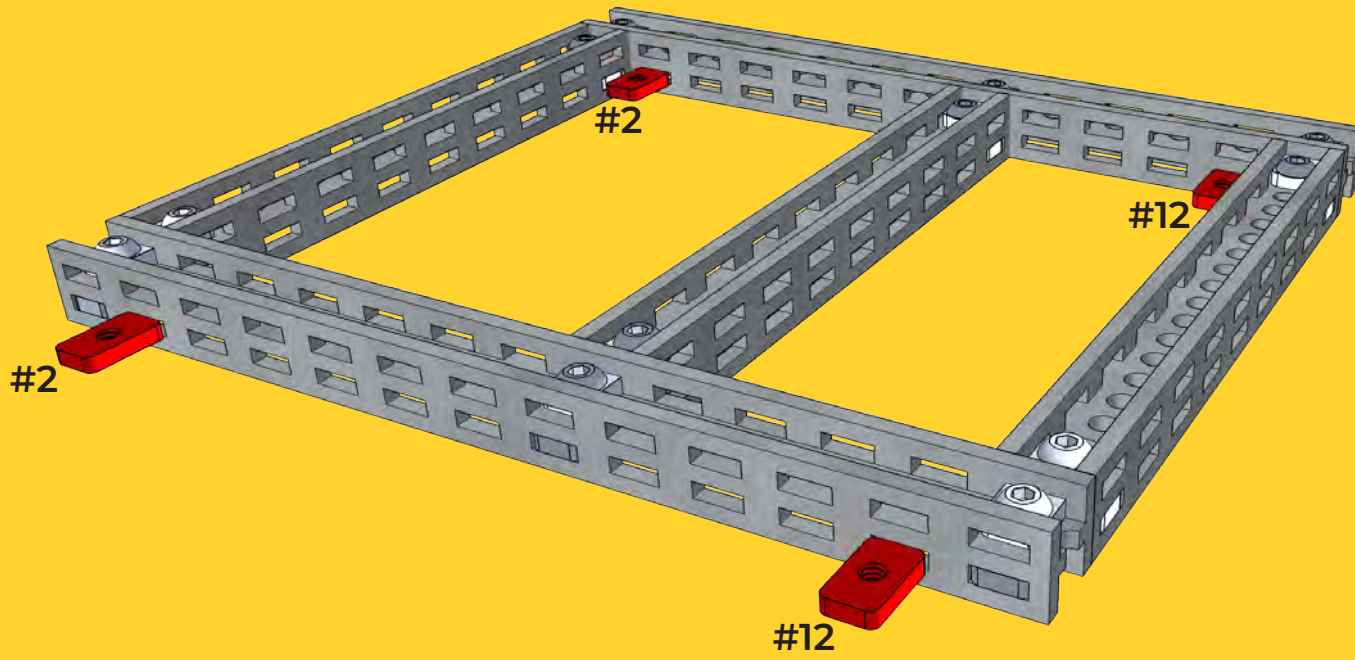

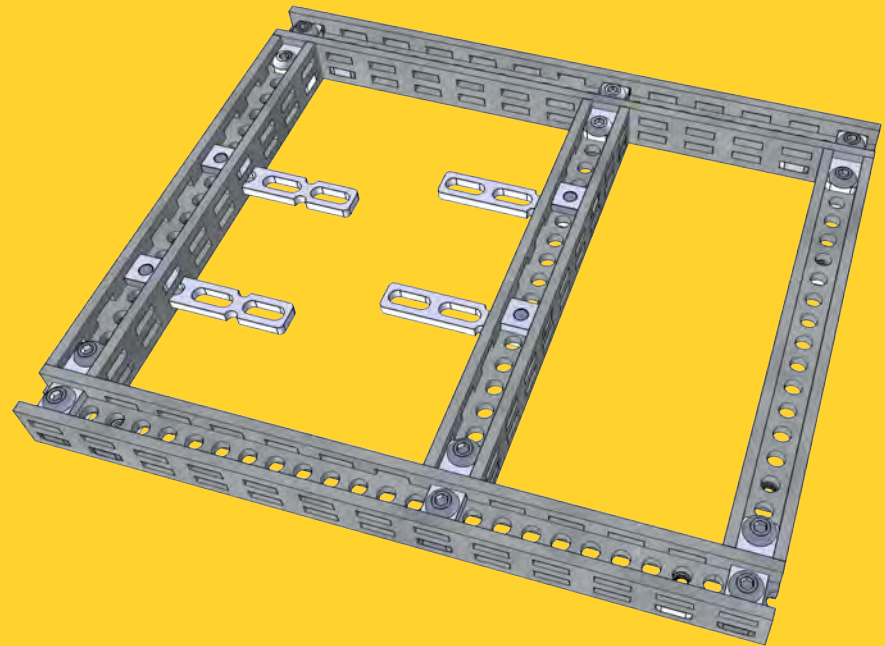
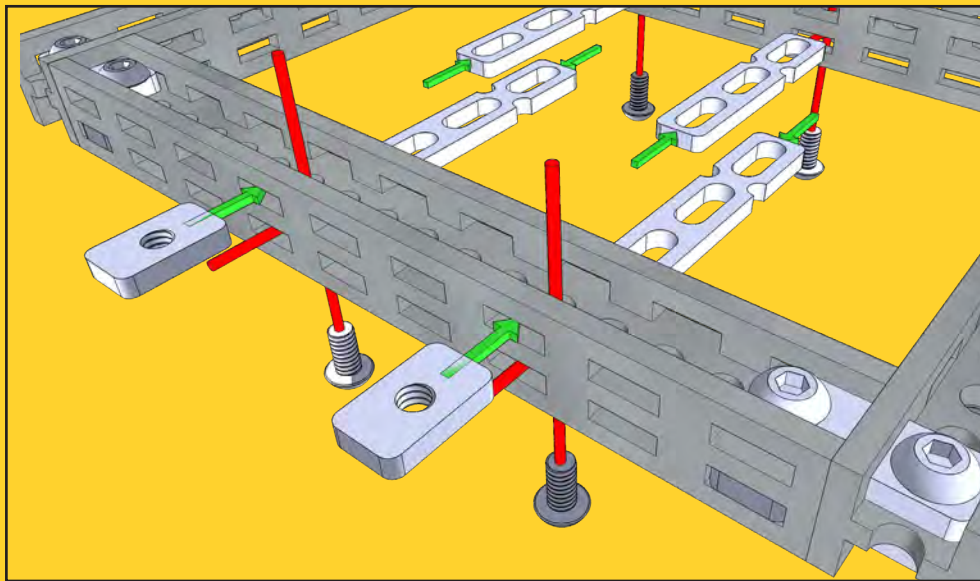
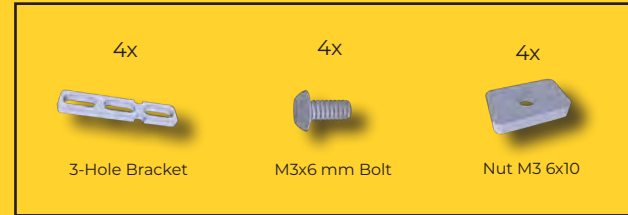
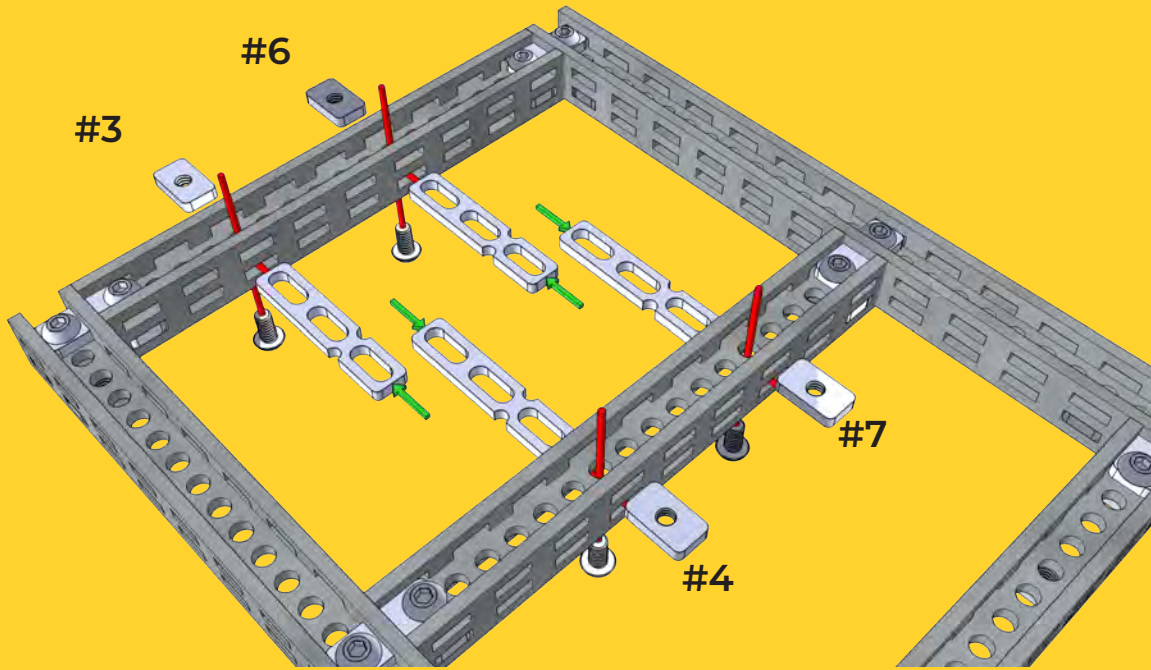

4

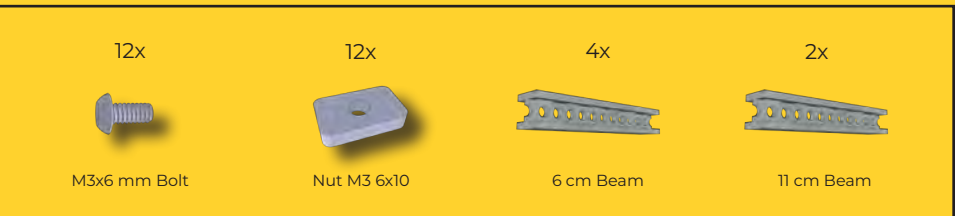
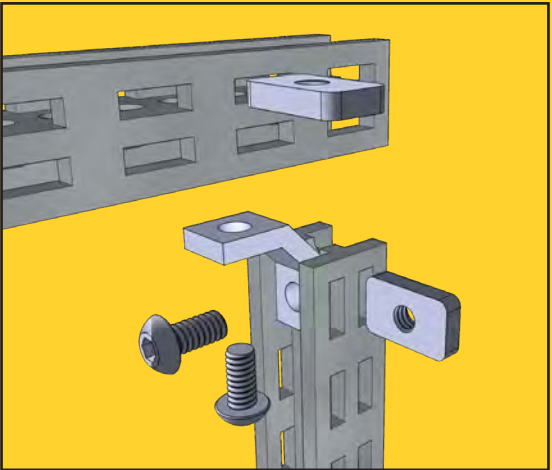
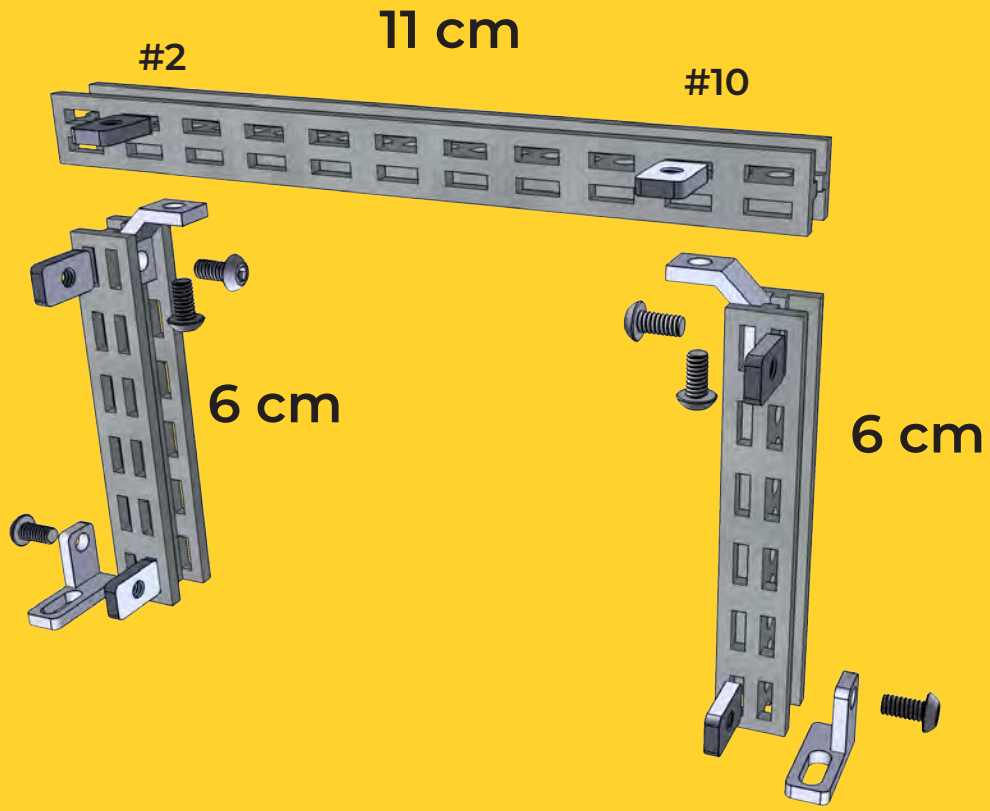

Repeat this step 2 times.

2x

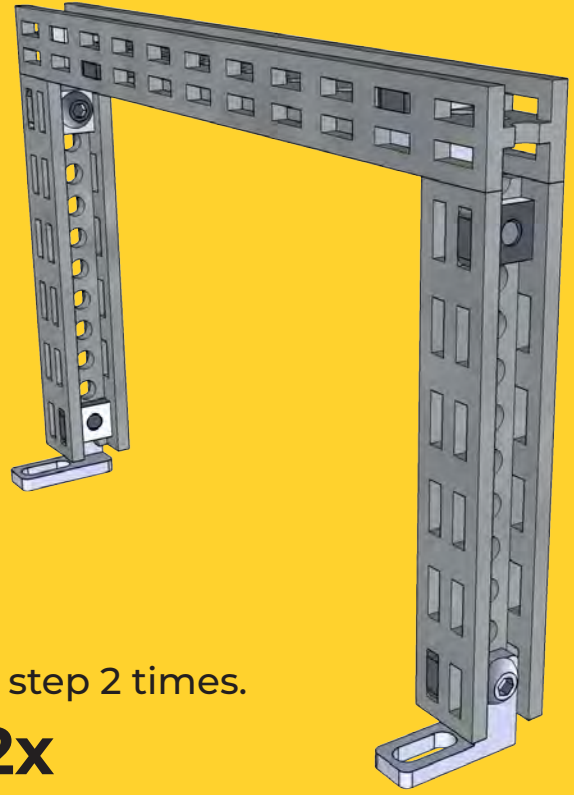

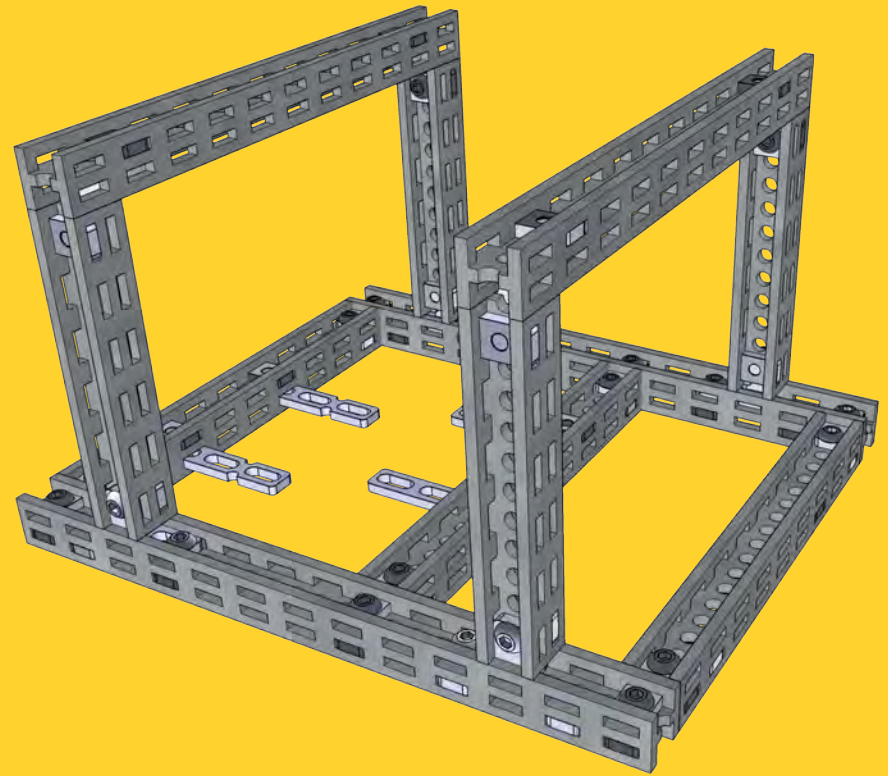
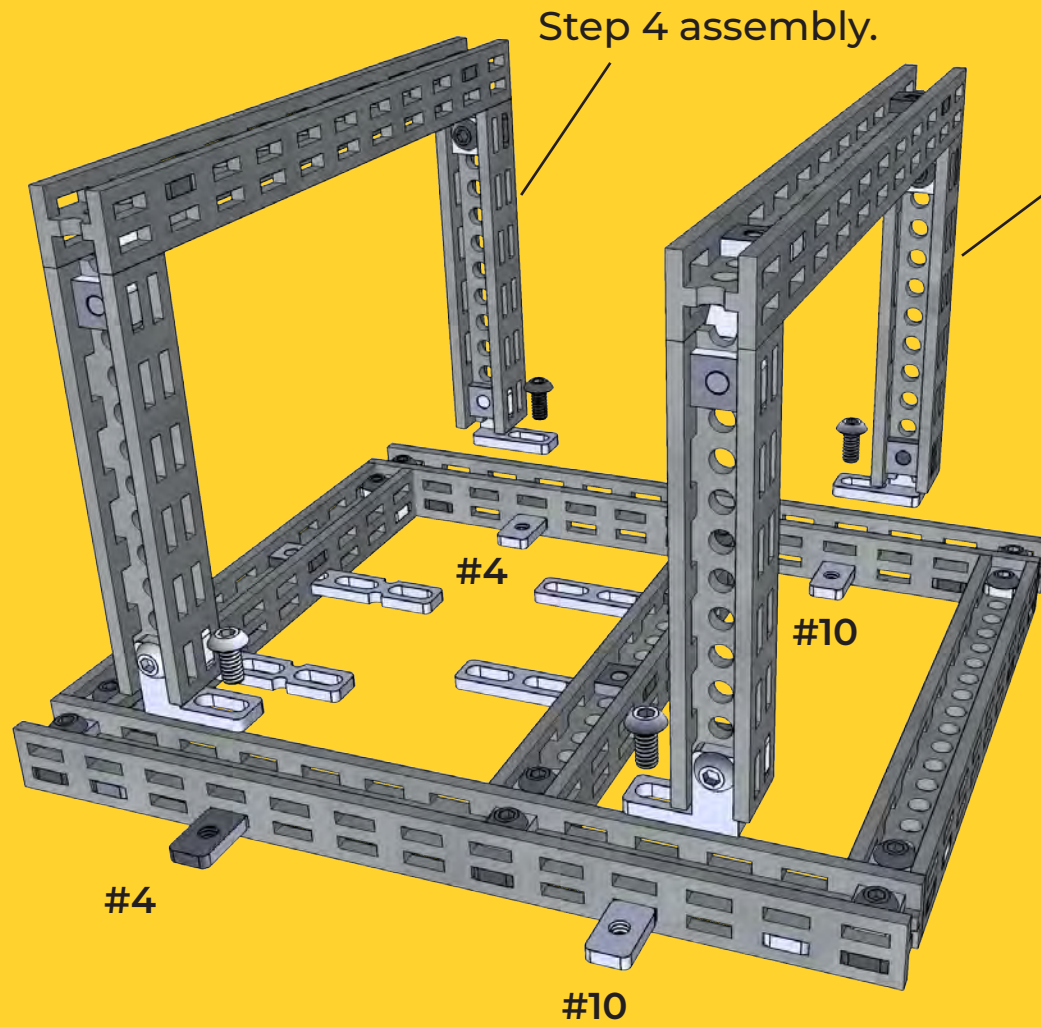

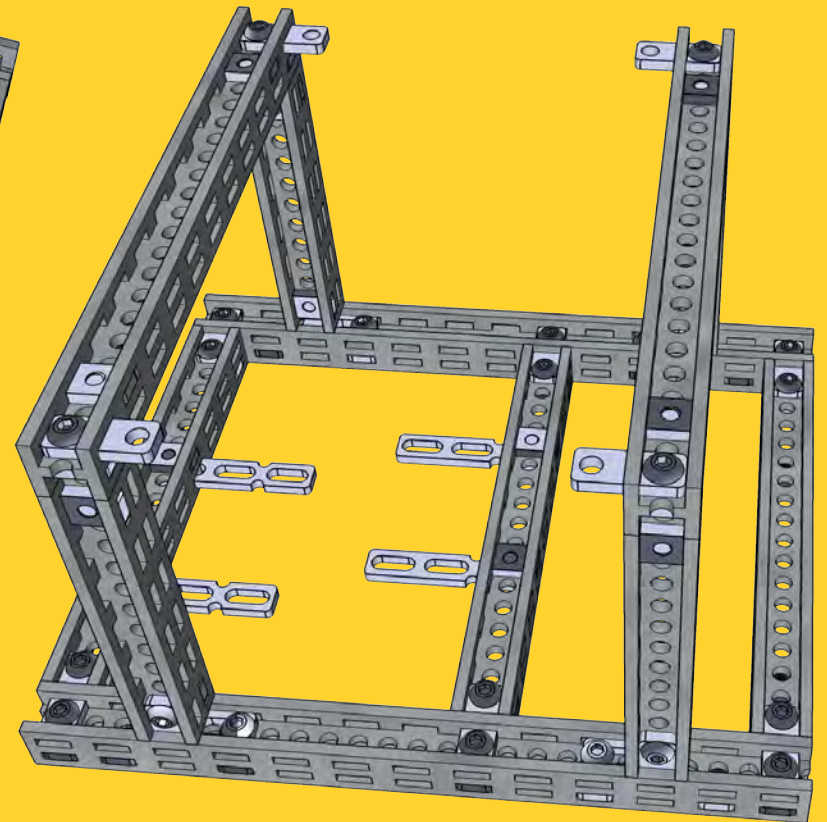
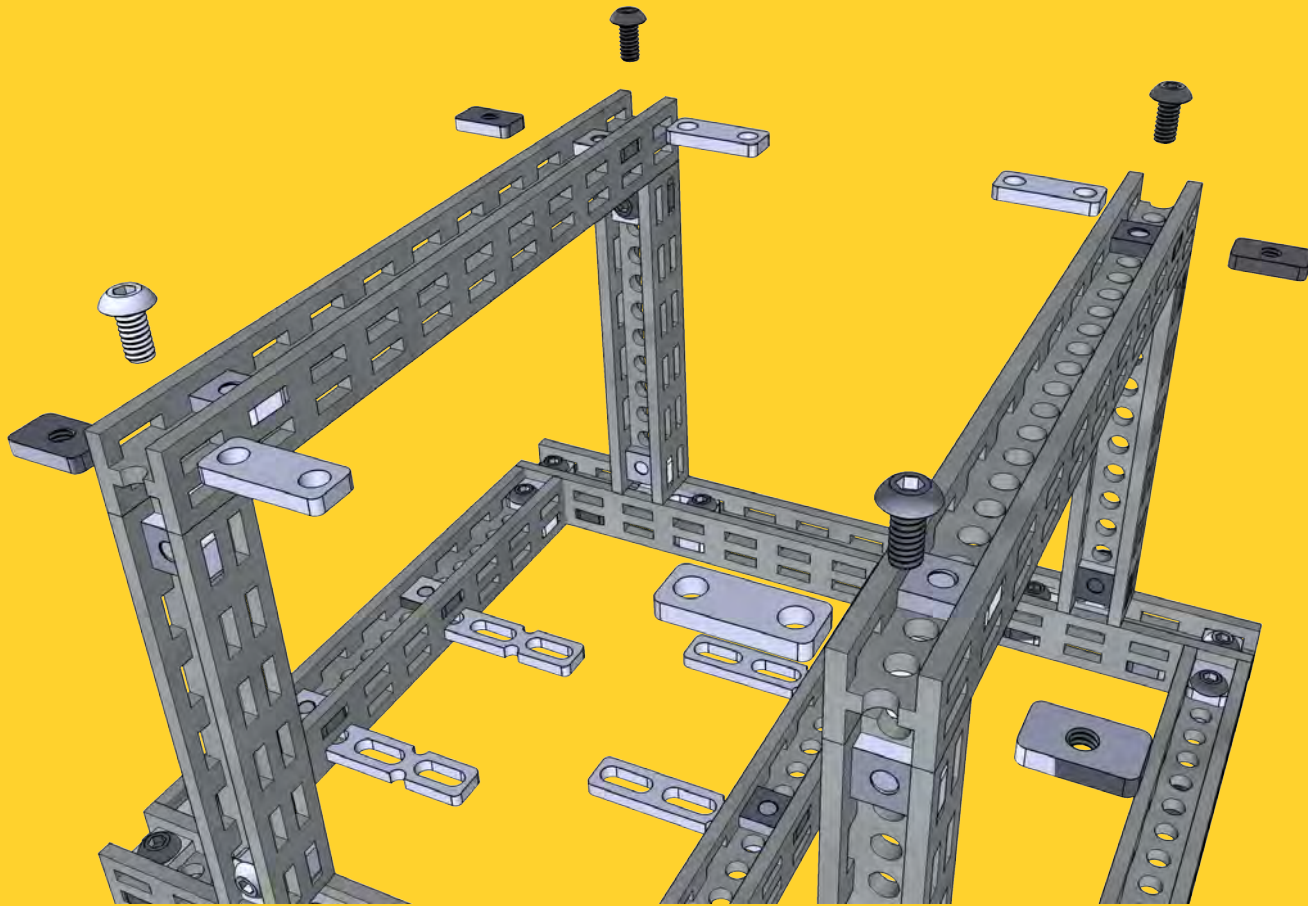



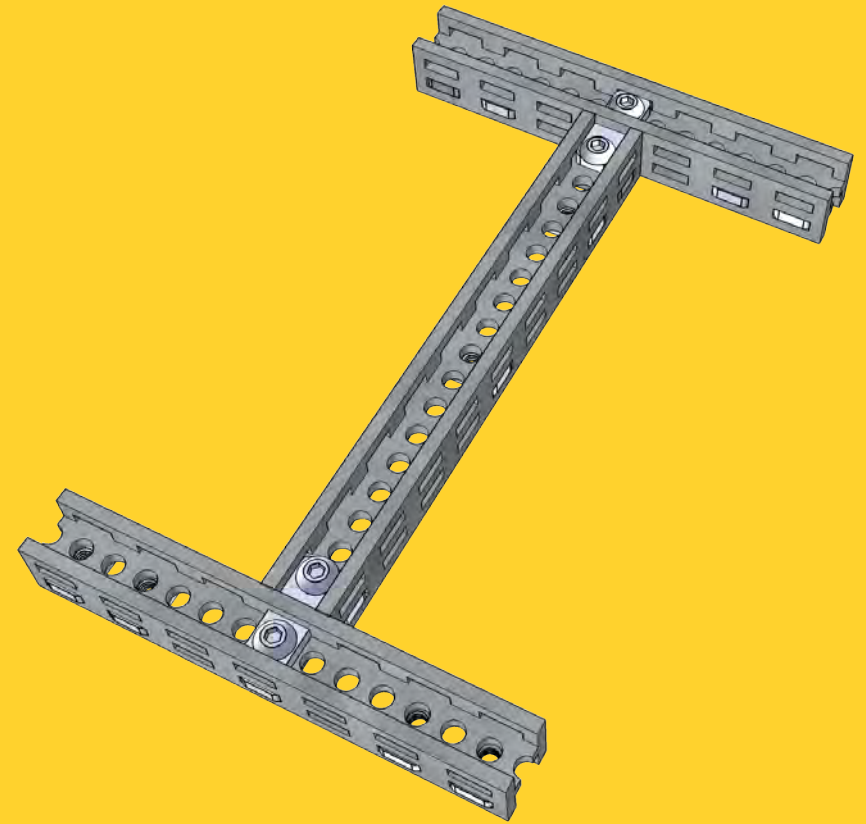
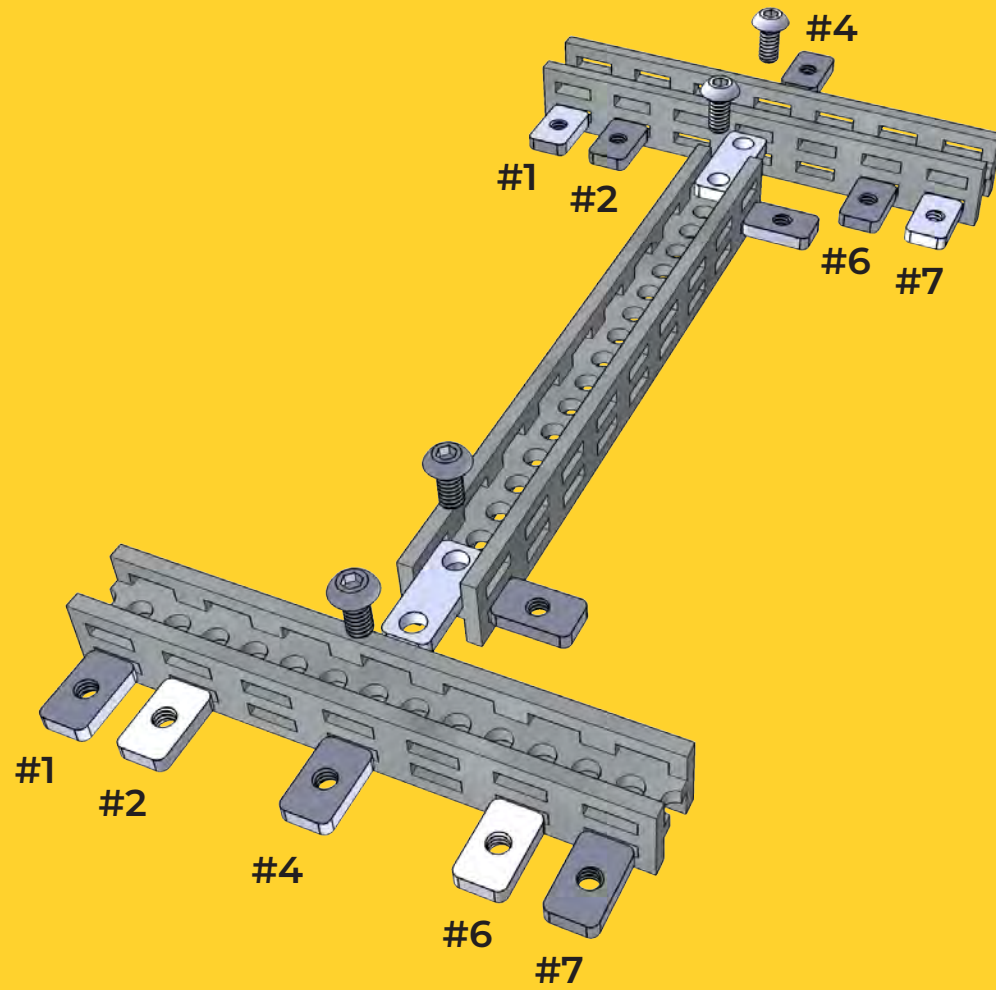





4x	4x	4x
		
M3x6 mm Bolt	Nut M3 6x10	2-Hole Simple Bracket

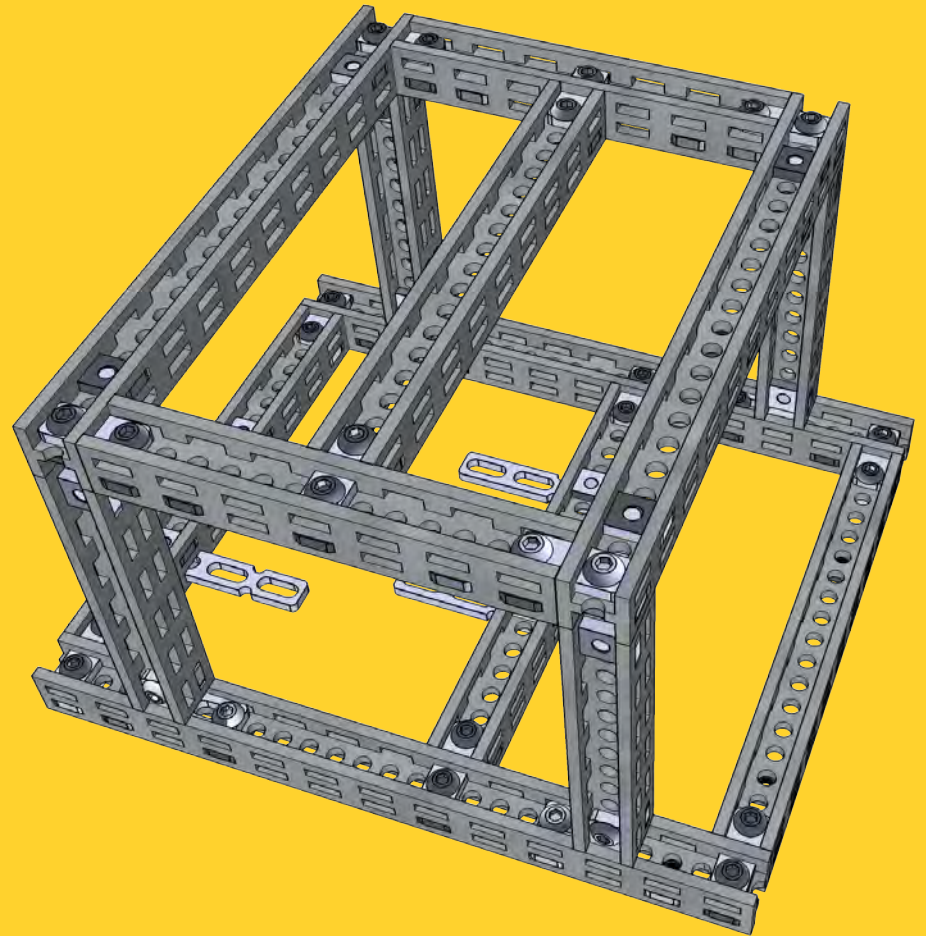
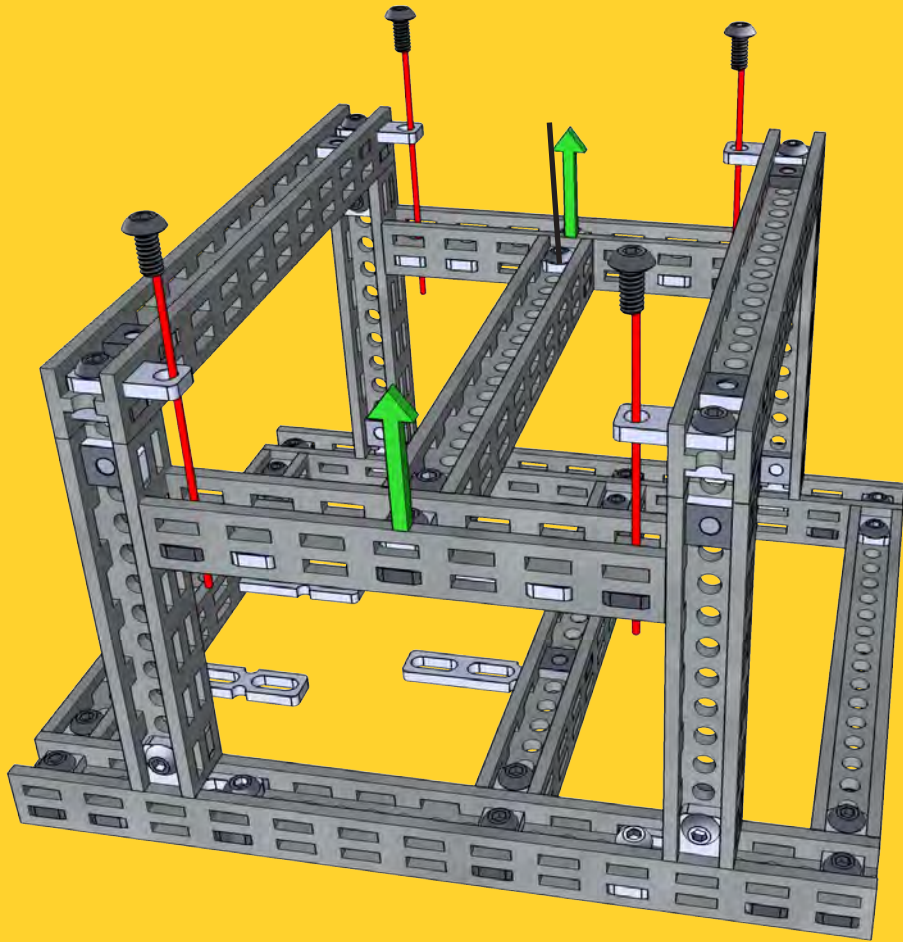

4x	12x	2x	2x	1x
				
M3x6 mm Bolt	Nut M3 6x10	2-Hole Simple Bracket	7 cm Beam	9 cm Beam



4x	1x	1x
		
M3x6 mm Bolt	Step 6 Assembly	Step 7 Assembly

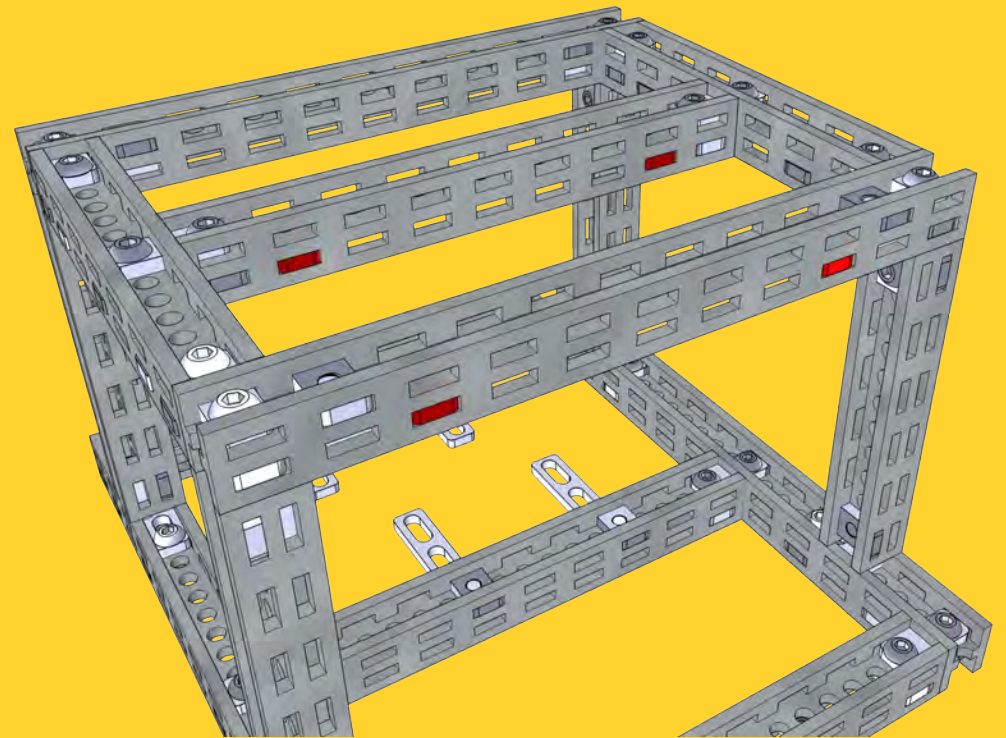
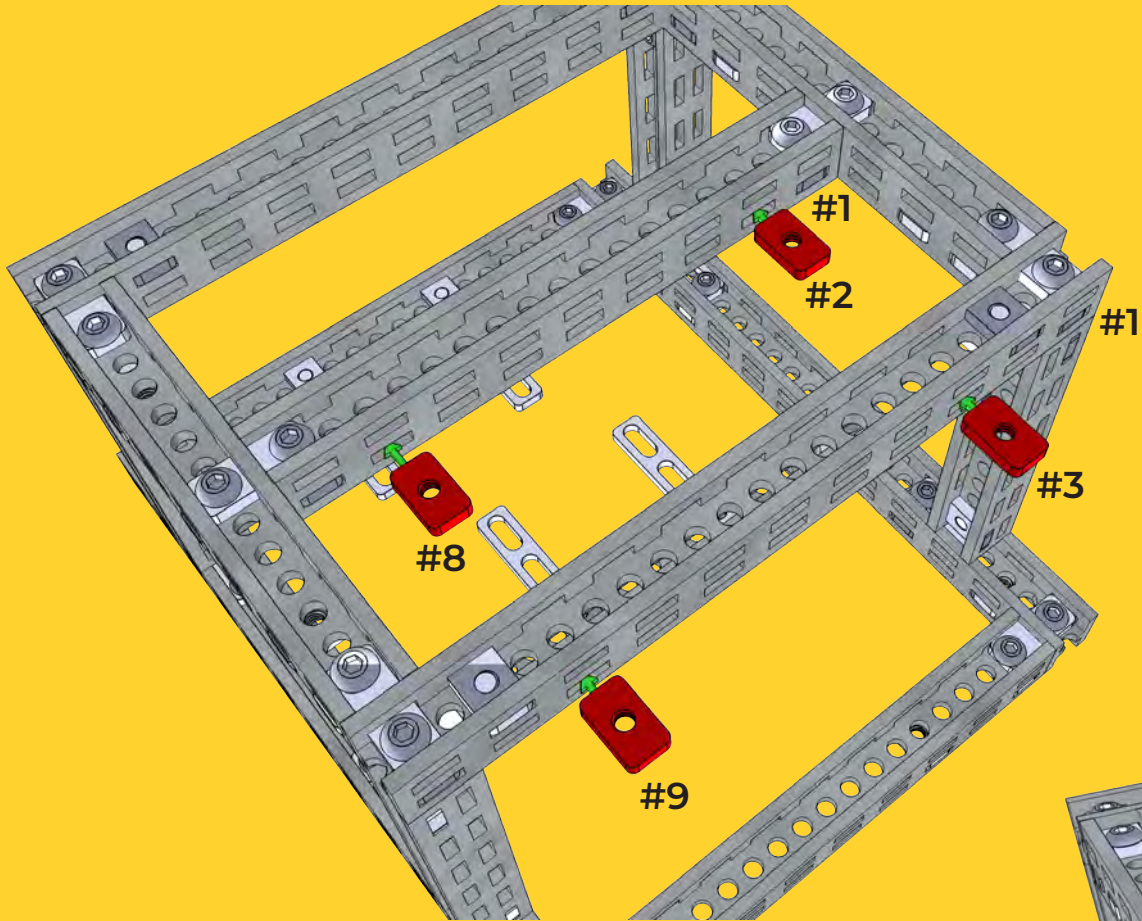

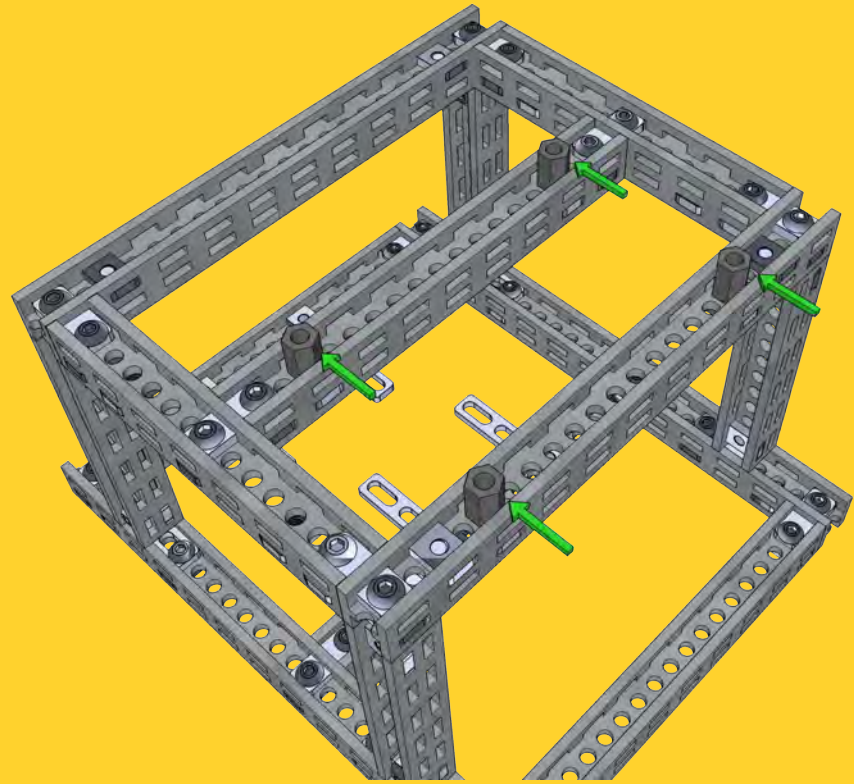
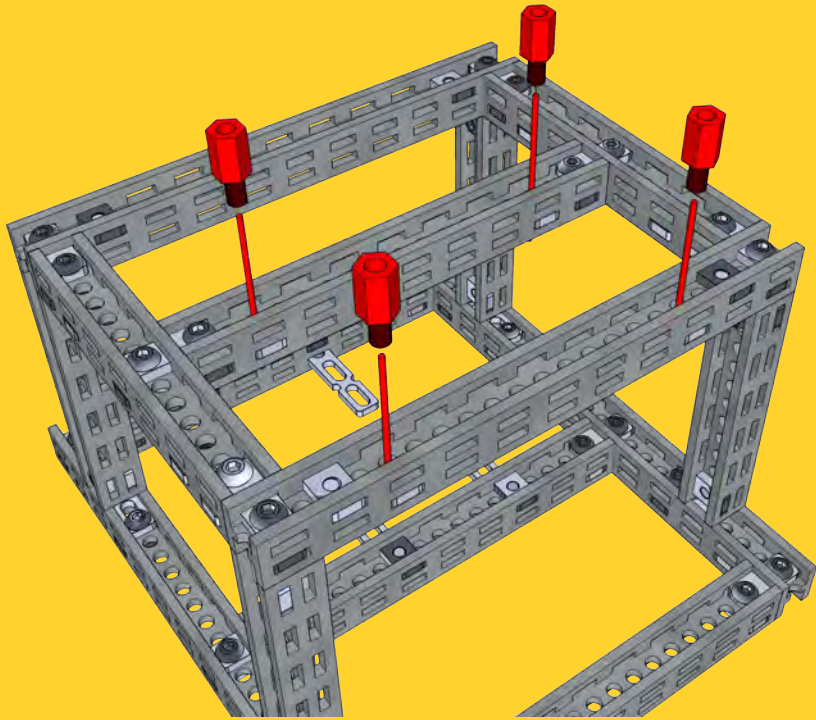

PART 8

1x ✓

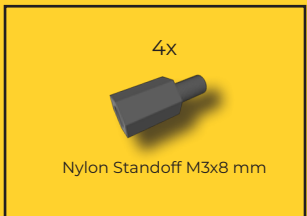
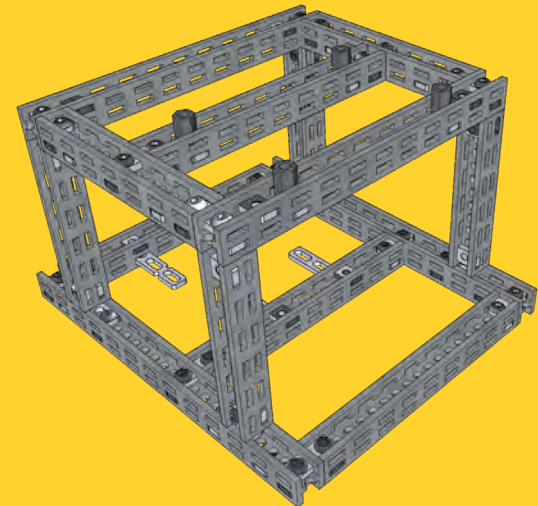

PART 9

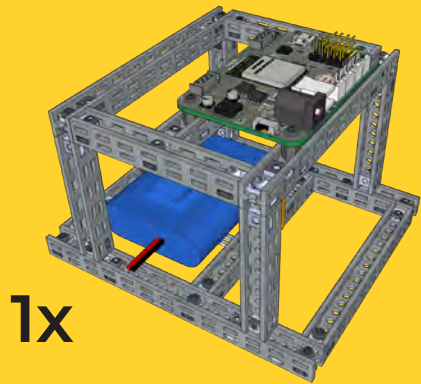

1x



RoboBoard X4

4x



M3x6 mm Bolt

1x



Zip Tie 25 mm

1x

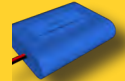

3x18650 Li-ion Pack.

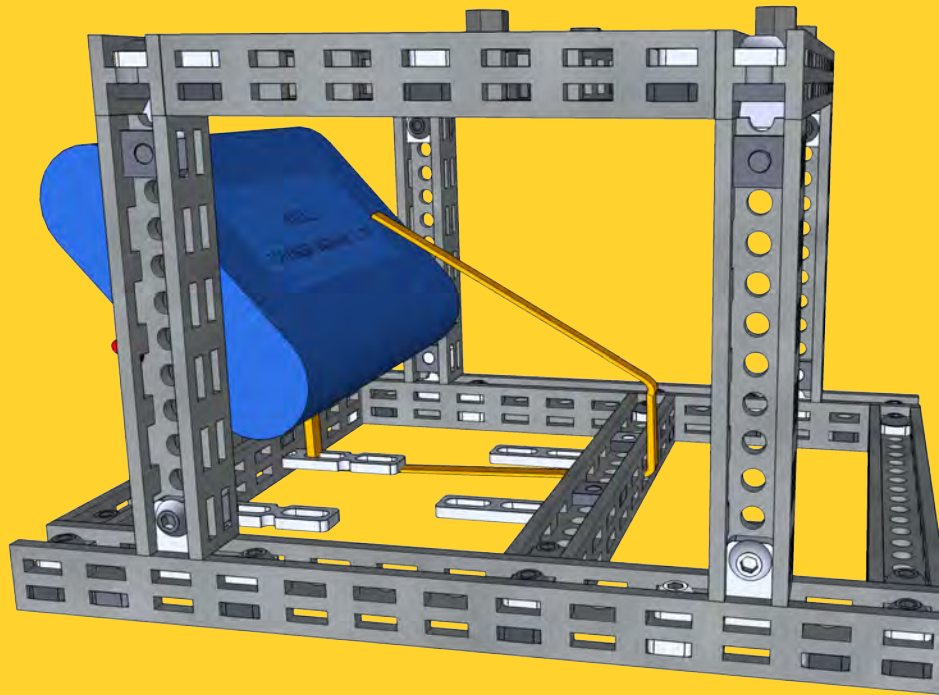

1x



Zip Tie 25 mm

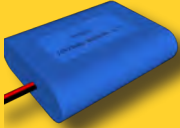

1x

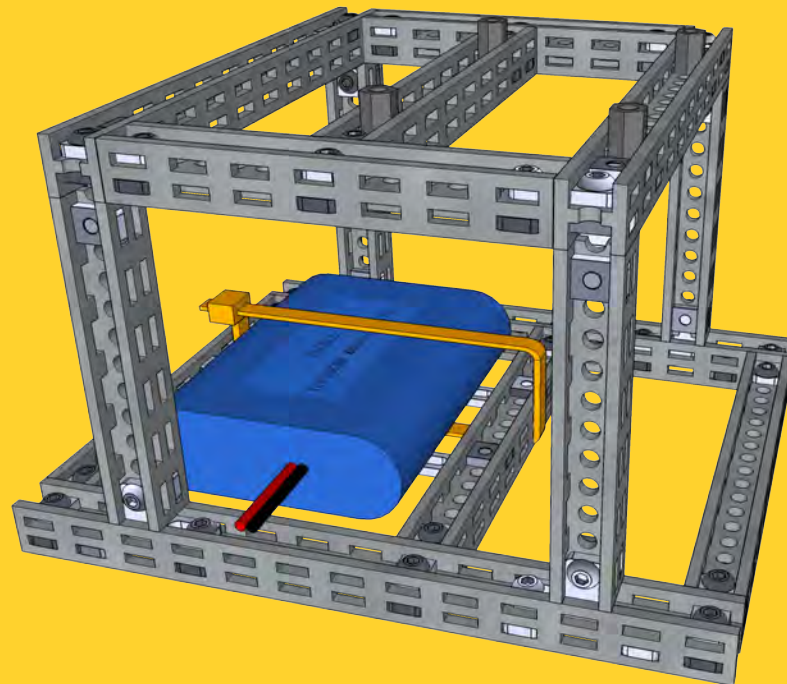

3x18650 Li-ion pack.

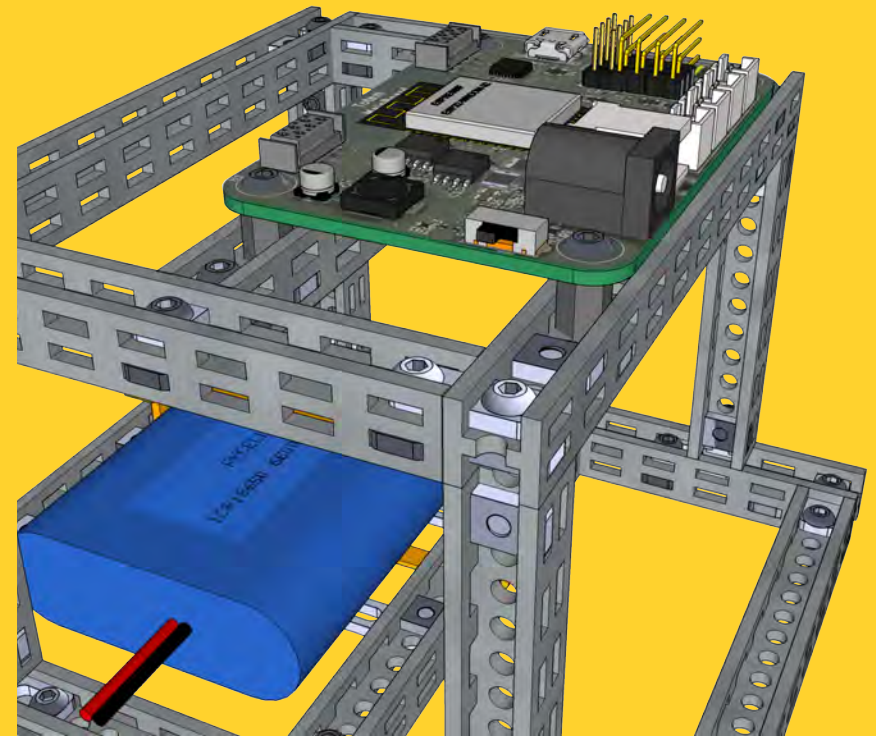
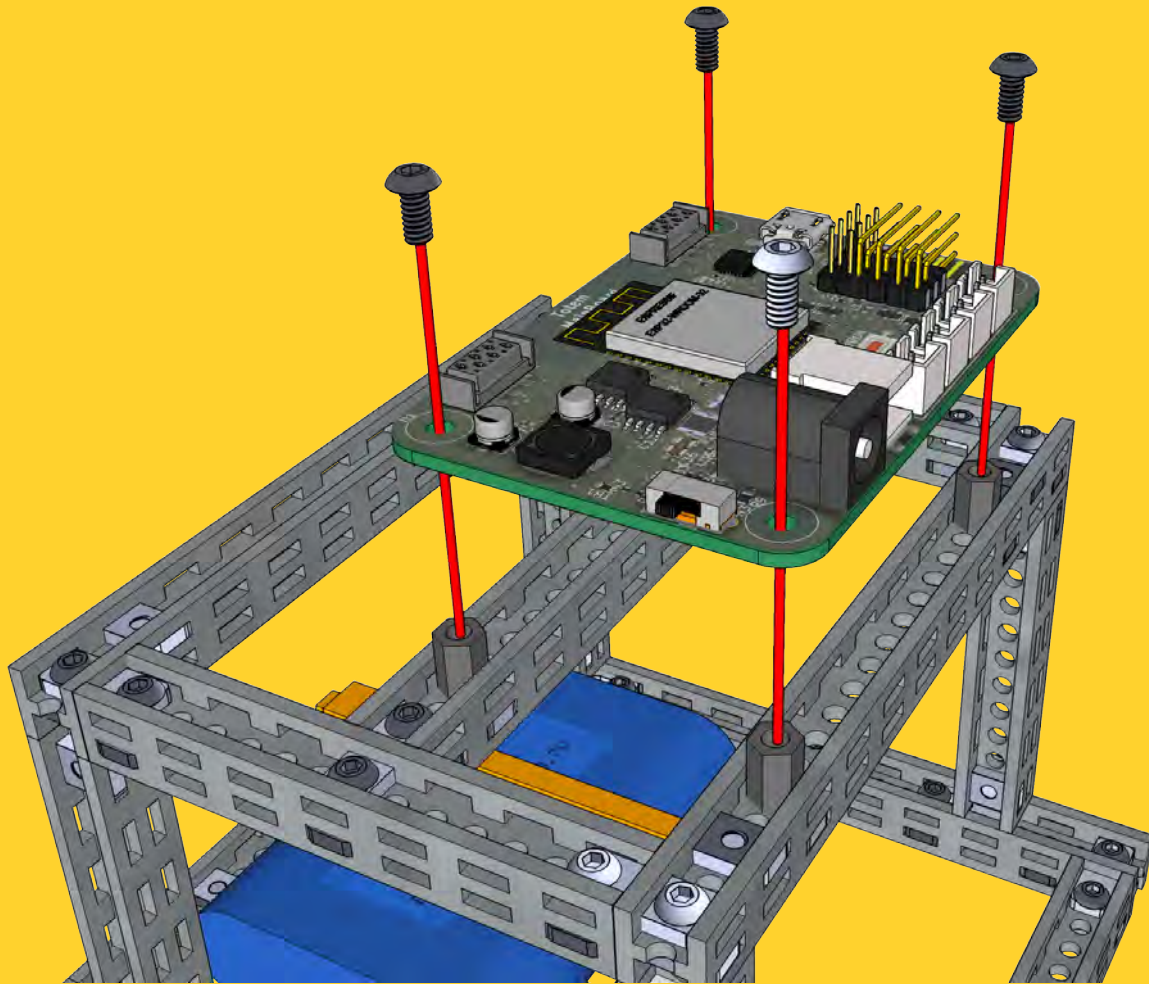



4x	1x
	
M3x6 mm Bolt	RoboBoard X4

3

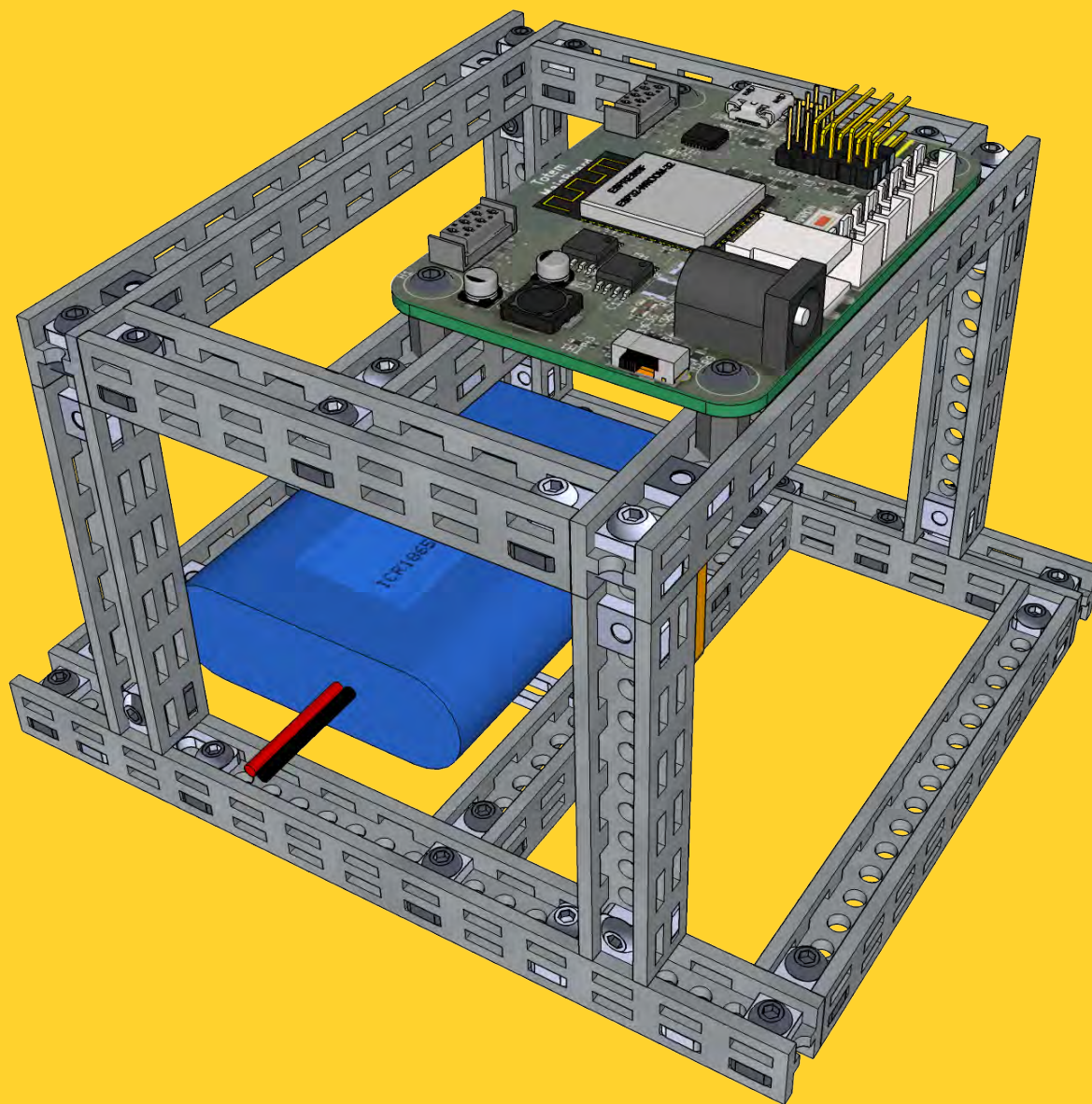

PART 9

1x ✓

PART 10

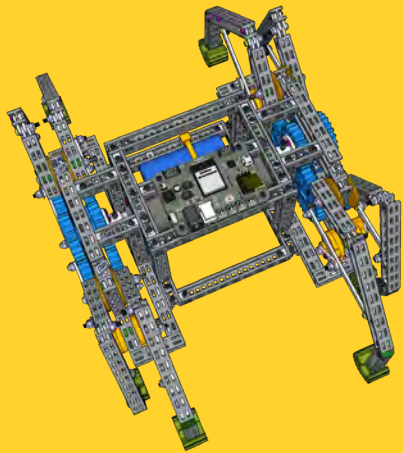

8x



M3x6 mm Bolt

4x



M3x6 mm Bolt

1

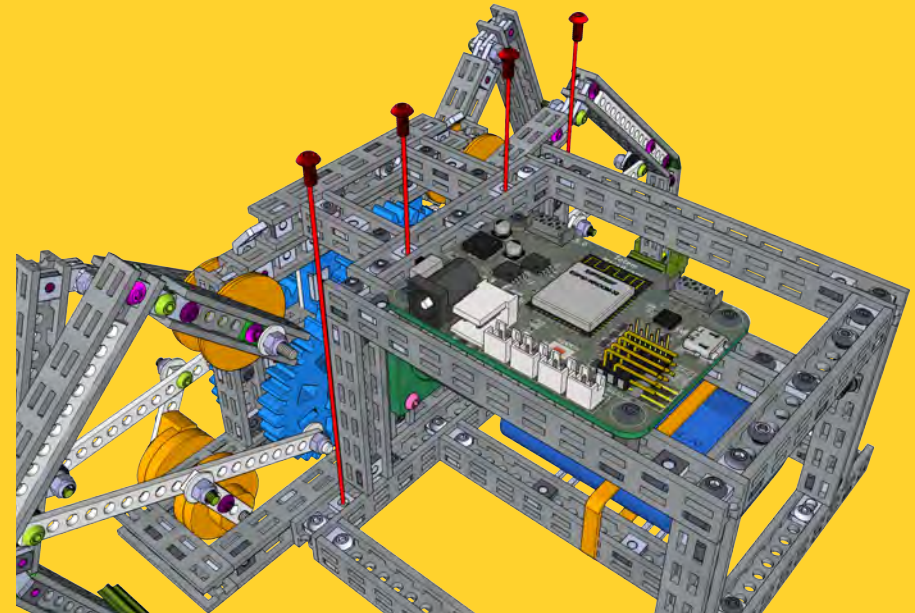
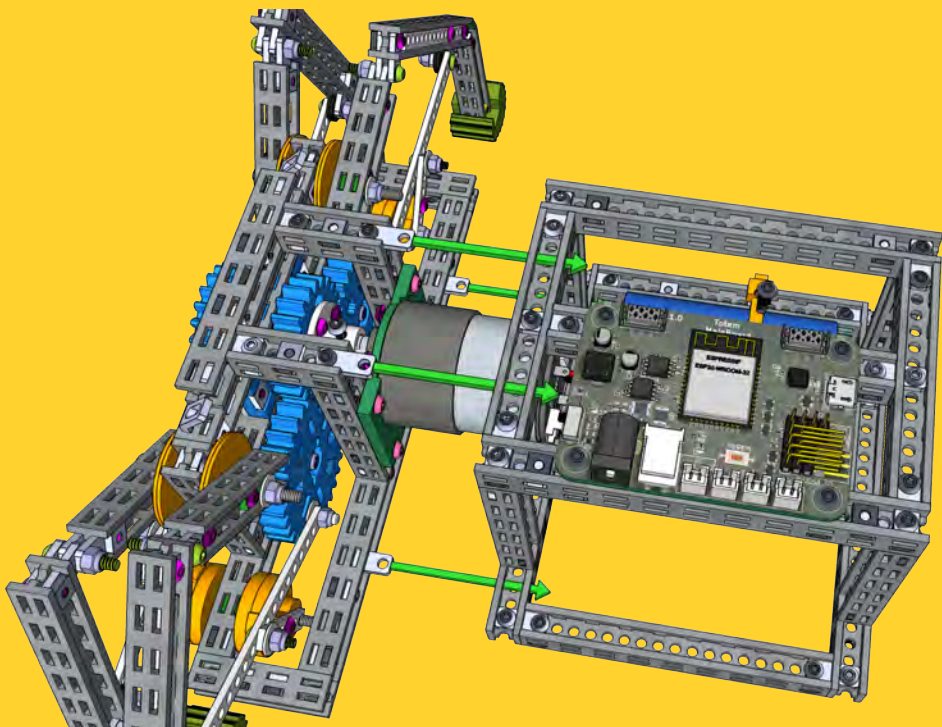
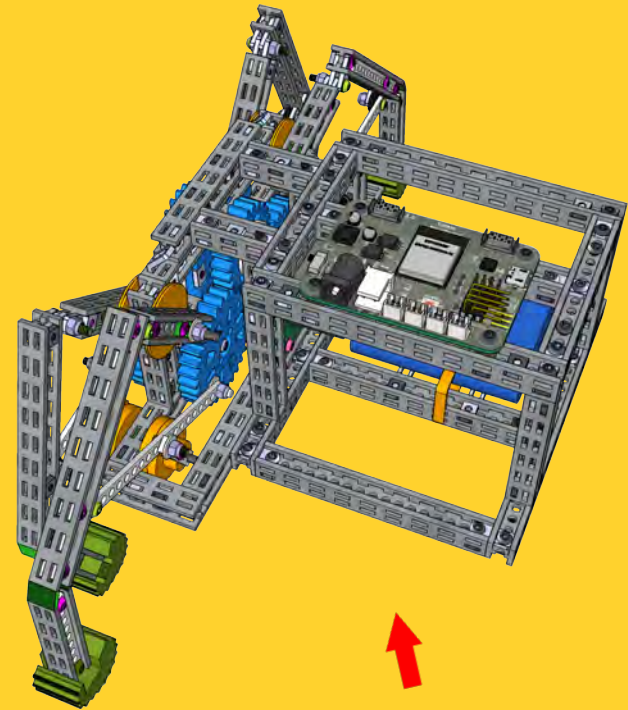

2

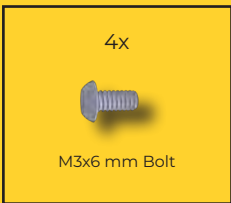
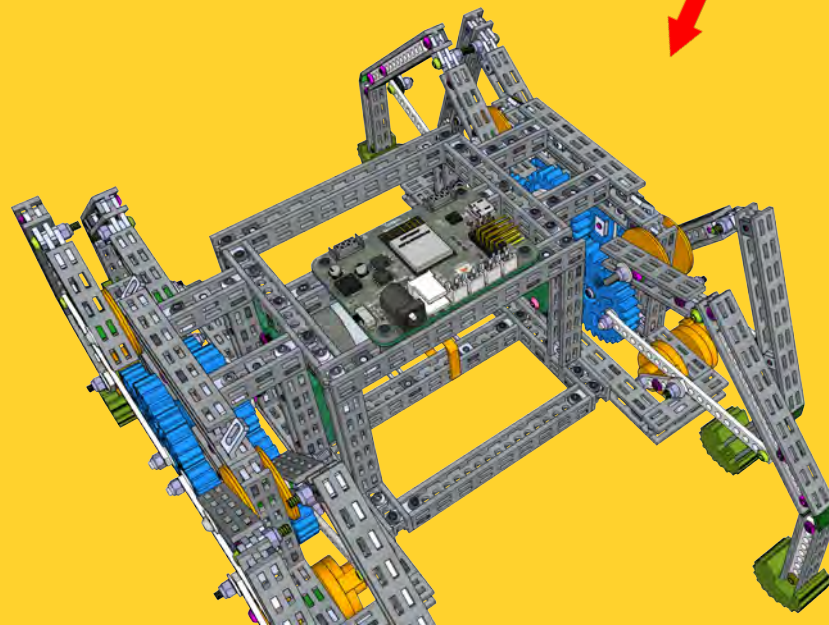
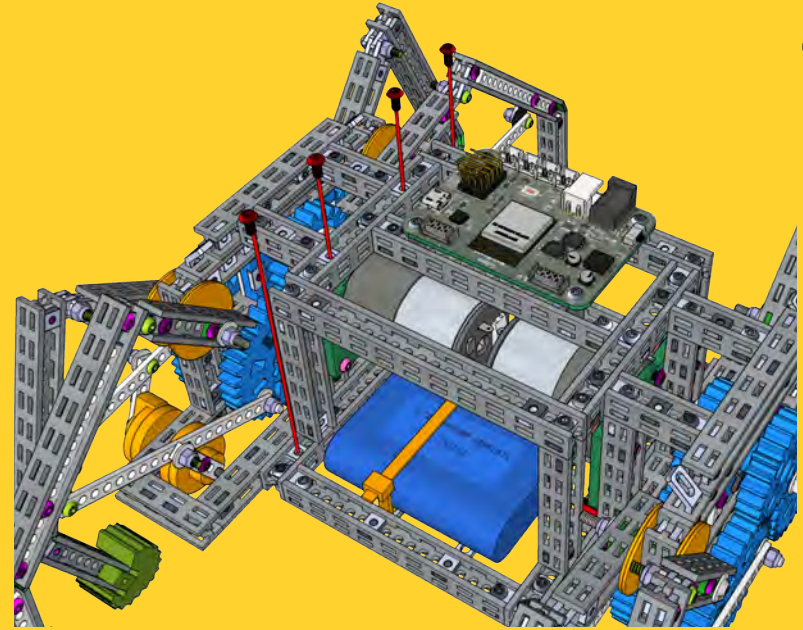
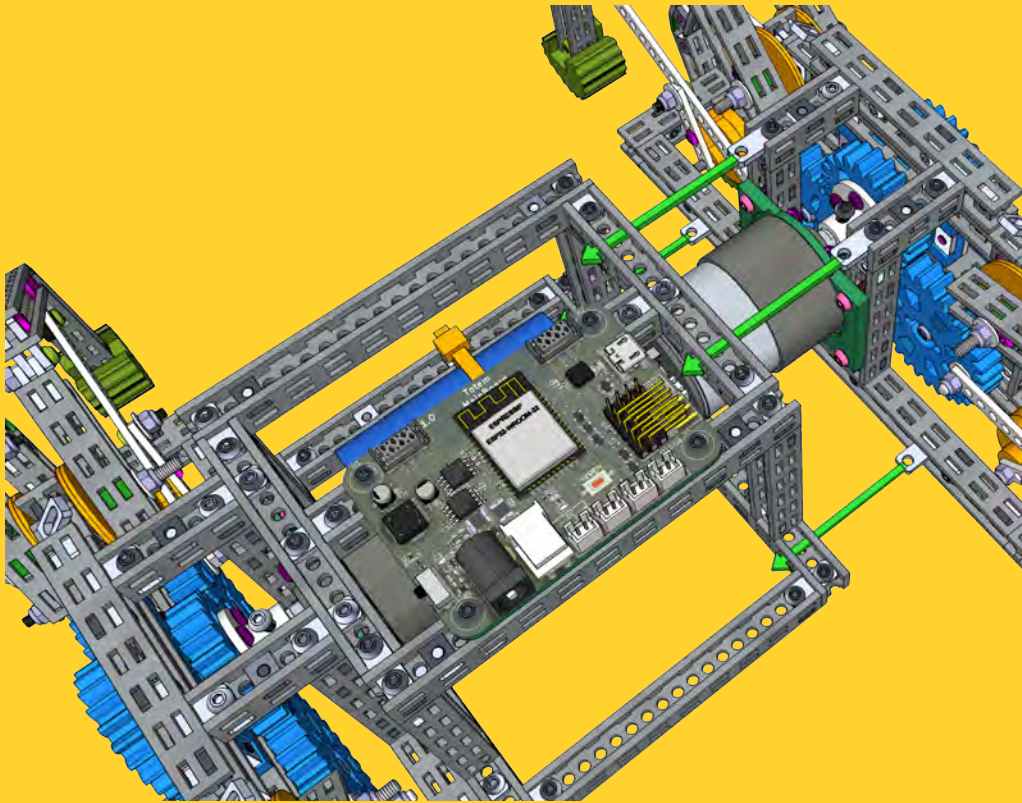

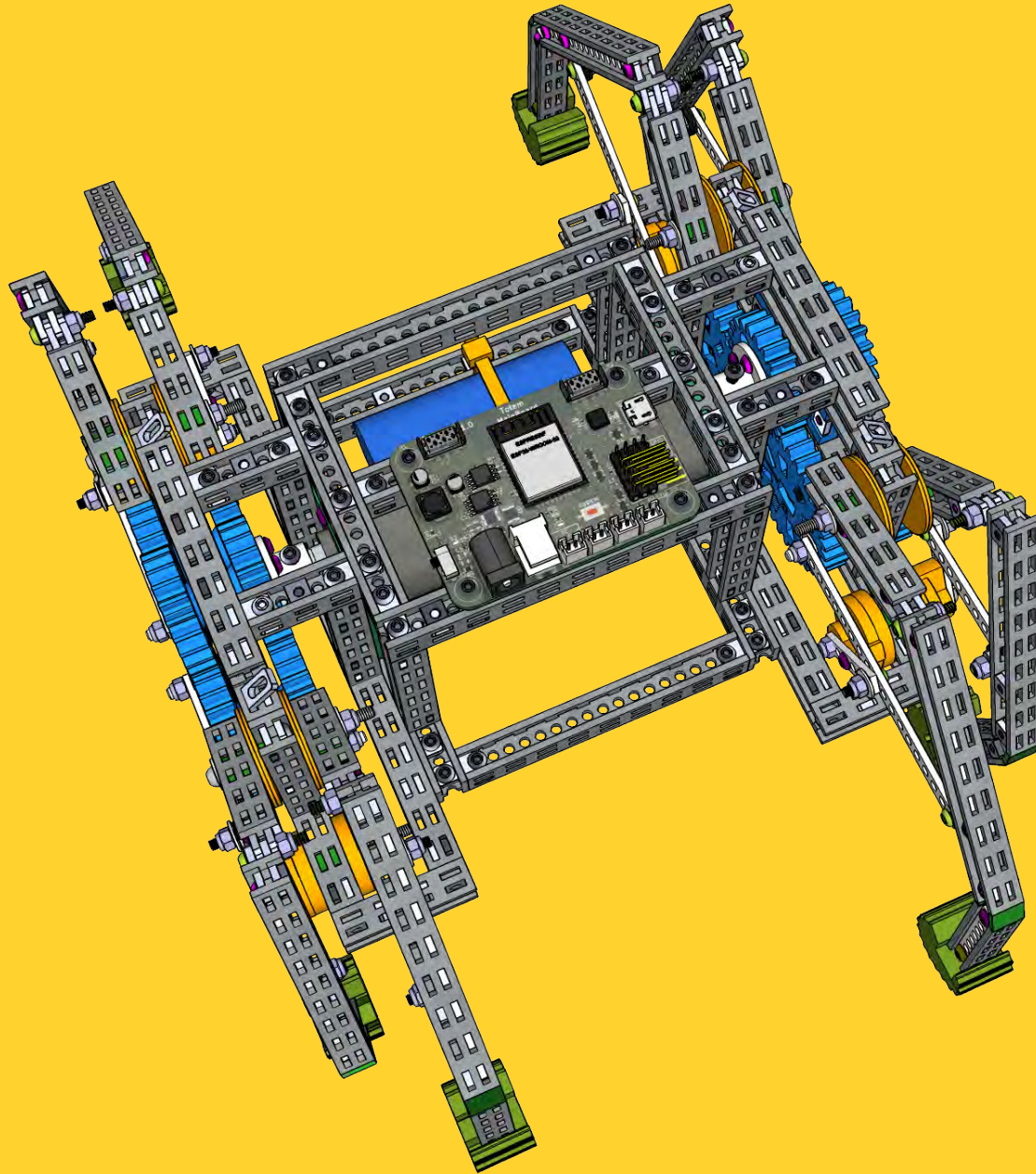

PART 3

1x ✓

PART 11

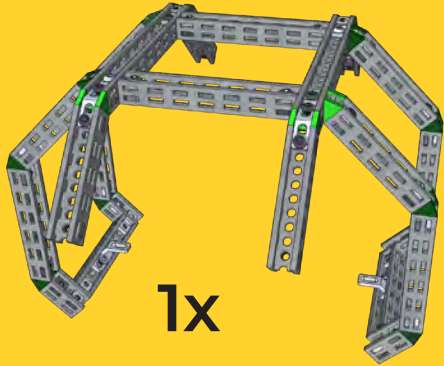

1x

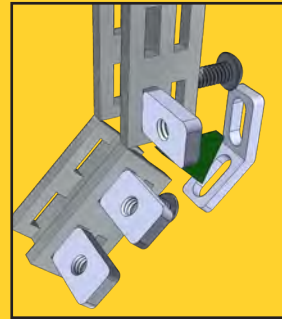
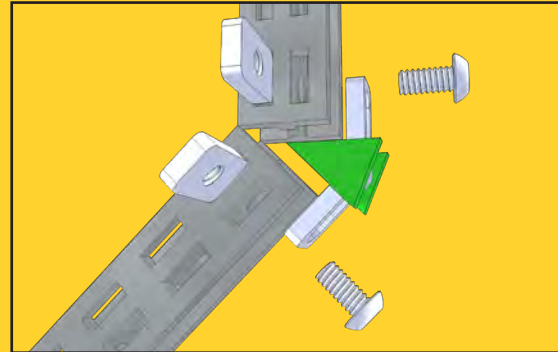
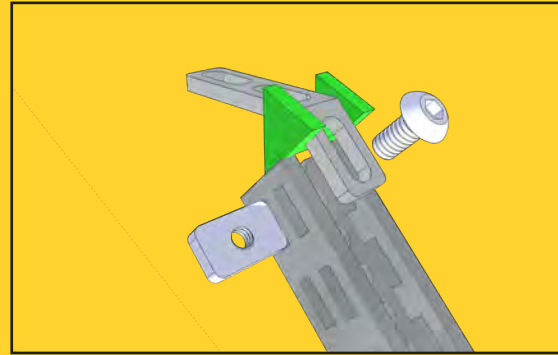
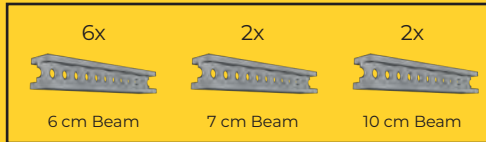
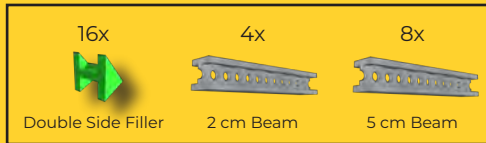
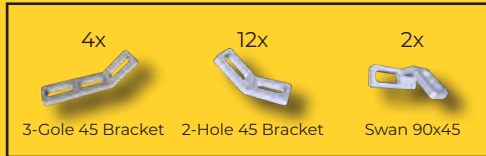

Repeat this step 4 times.

4x

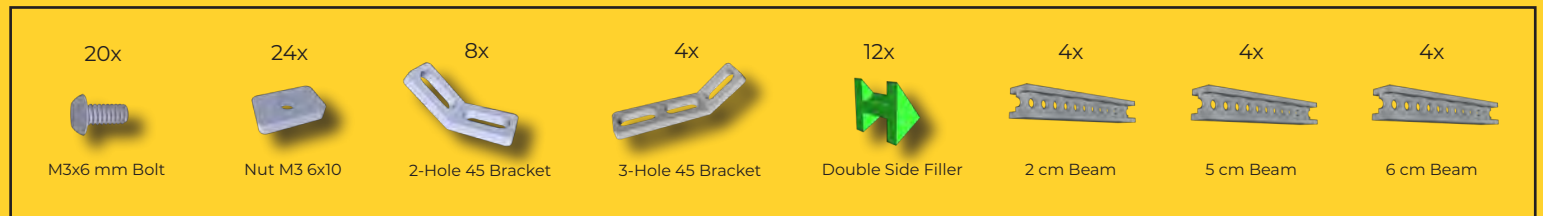



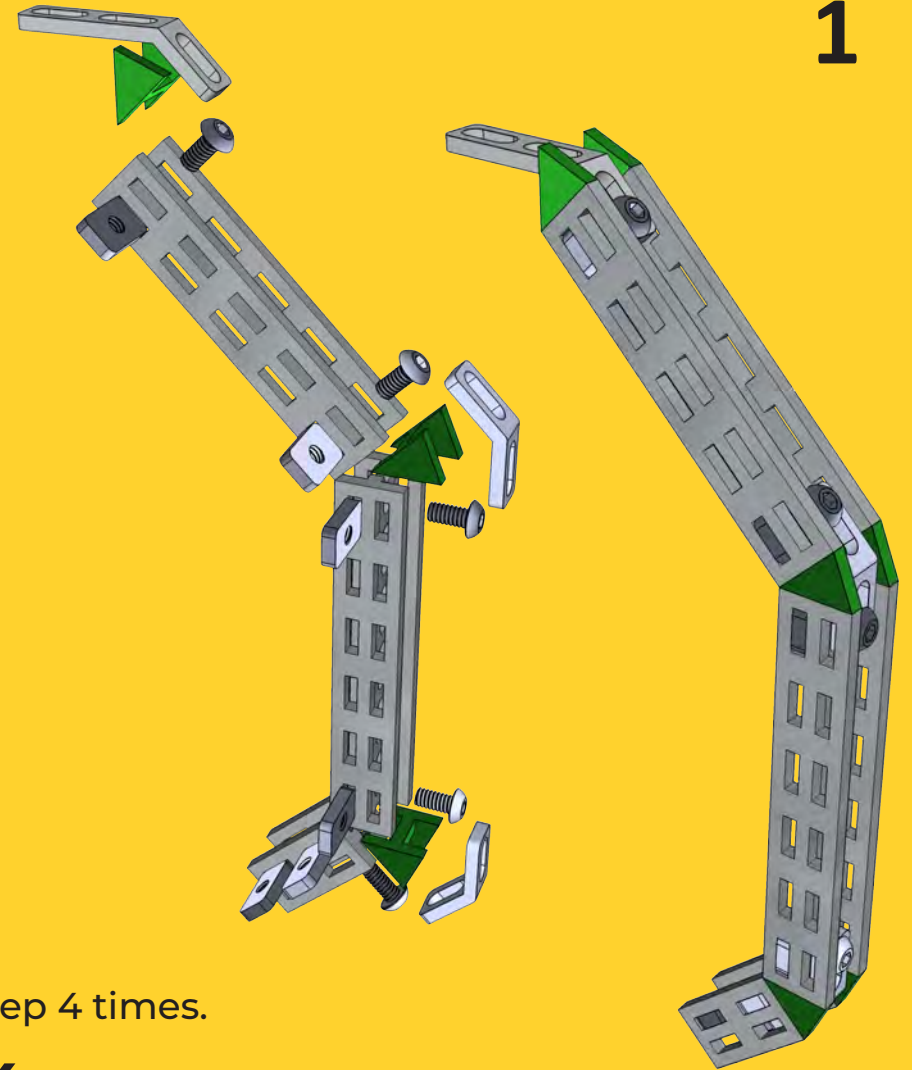

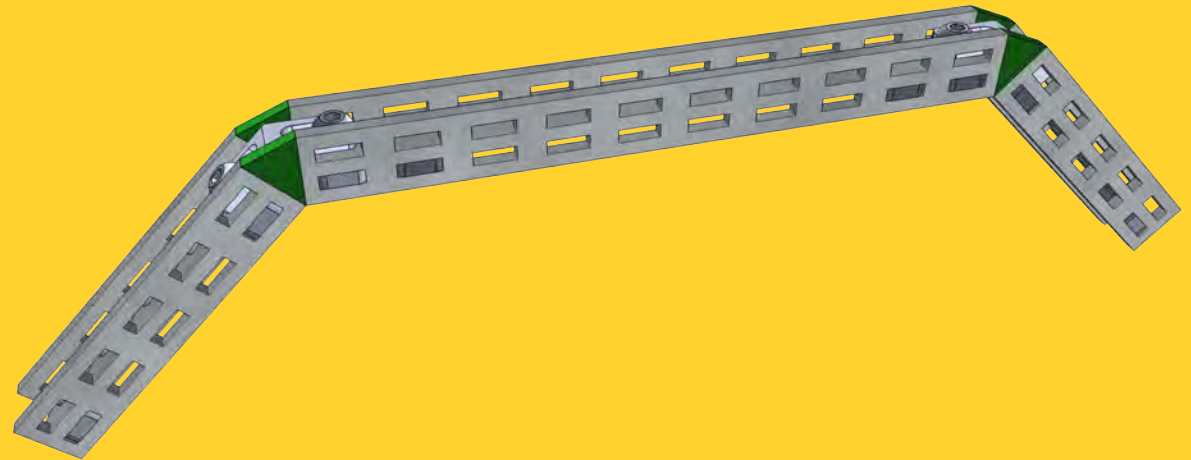
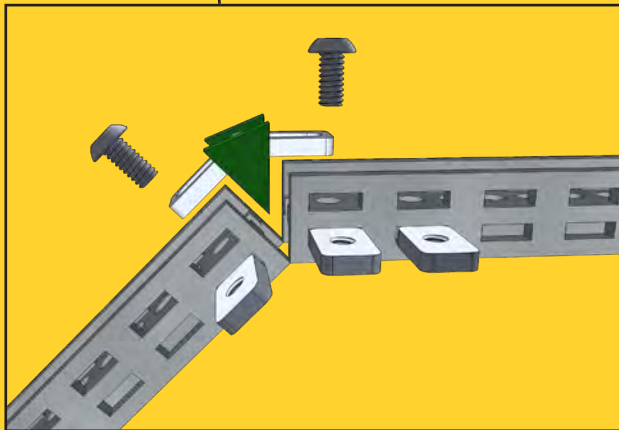
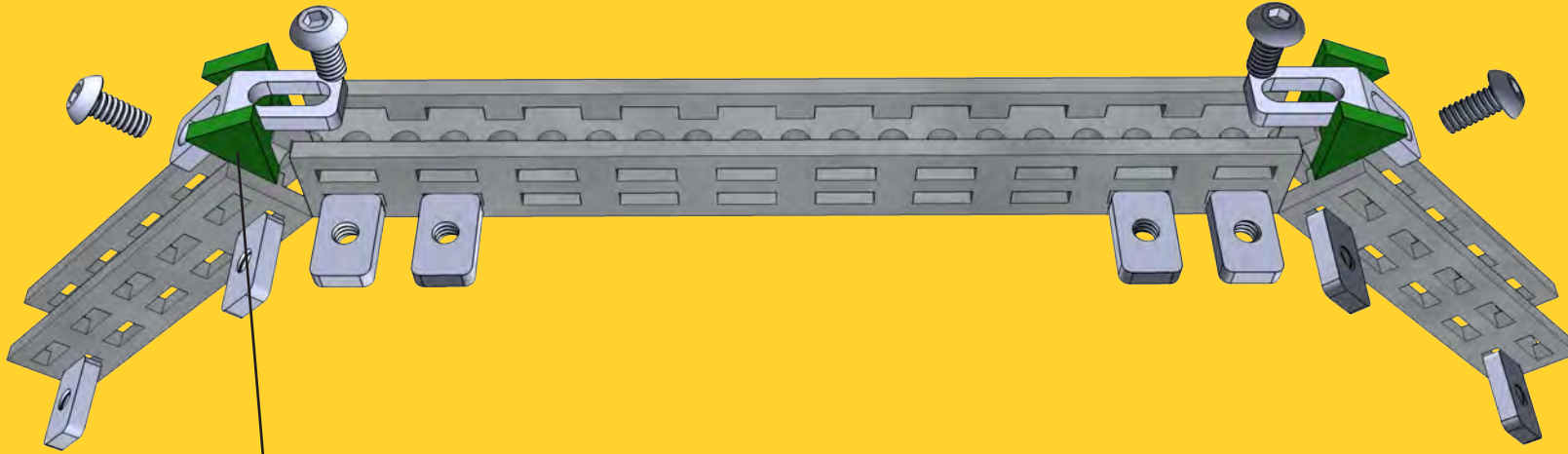

1



2



20x	24x	8x	12x	4x	2x
					
M3x6 mm Bolt	Nut M3 6x10	2-Hole 45 Bracket	Double Side Filler	5 cm Beam	10 cm Beam

Repeat this step 2 times.

2x

3

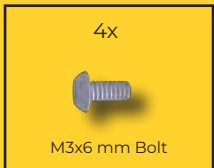
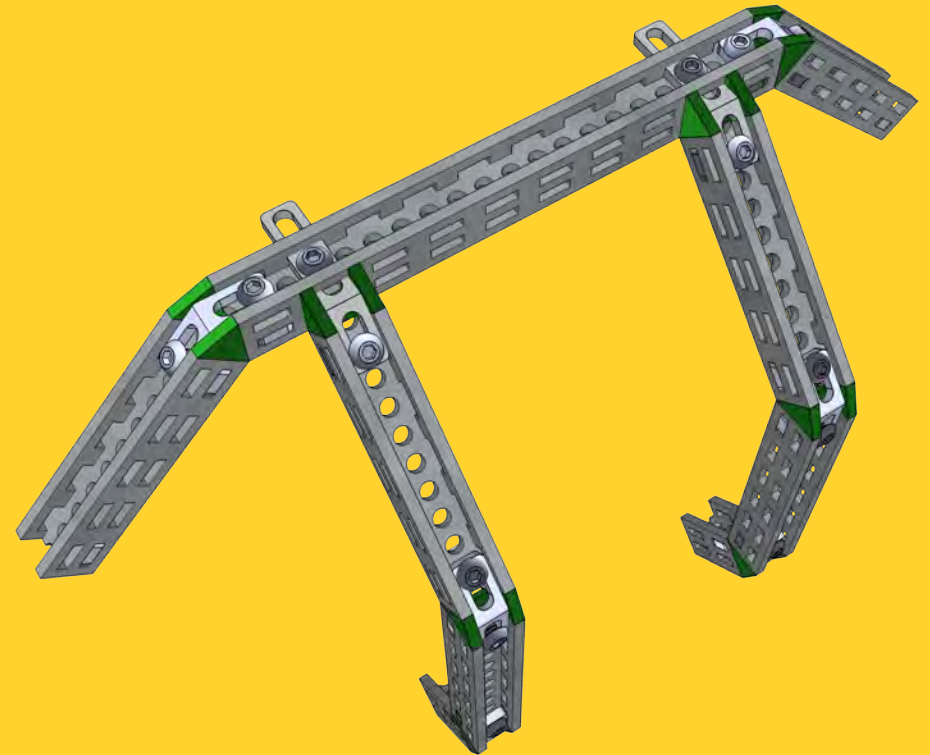
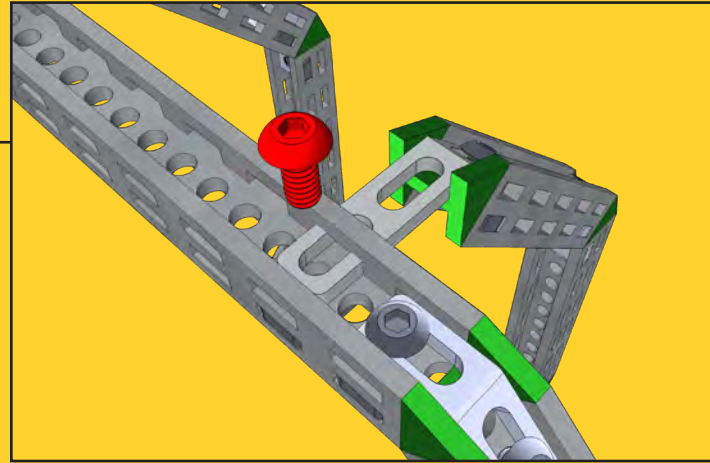
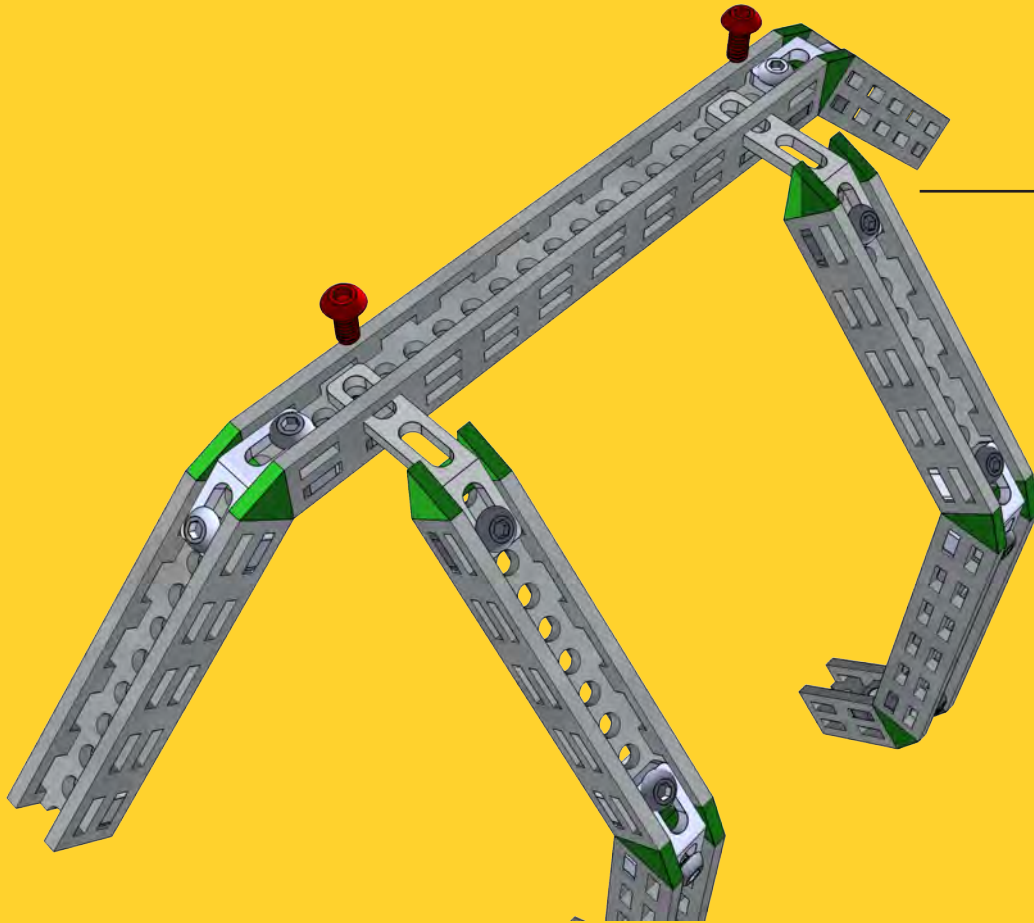

Repeat this step 2 times.

2x

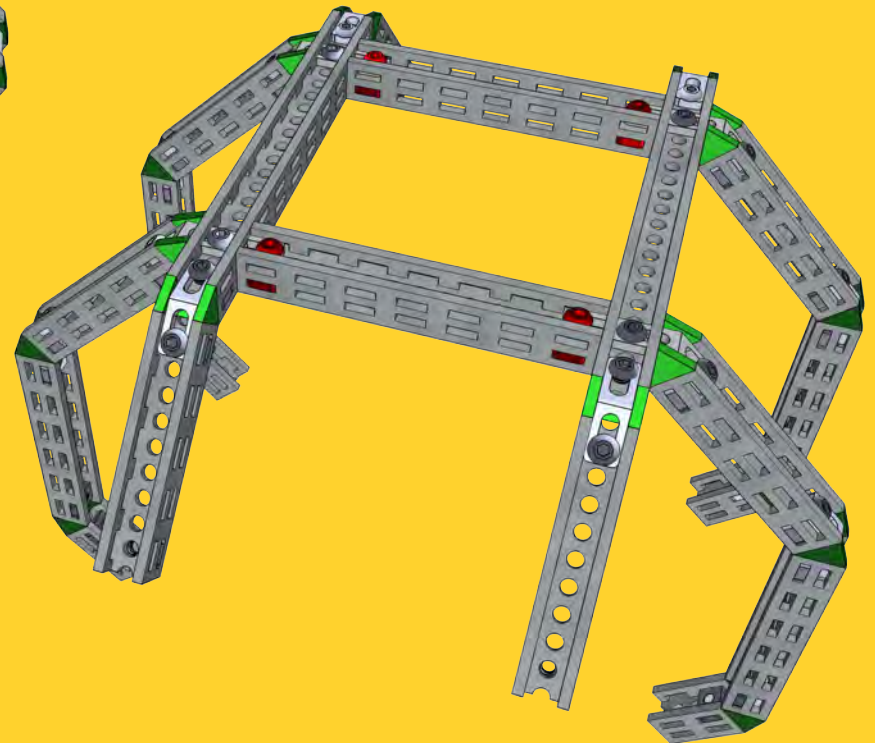
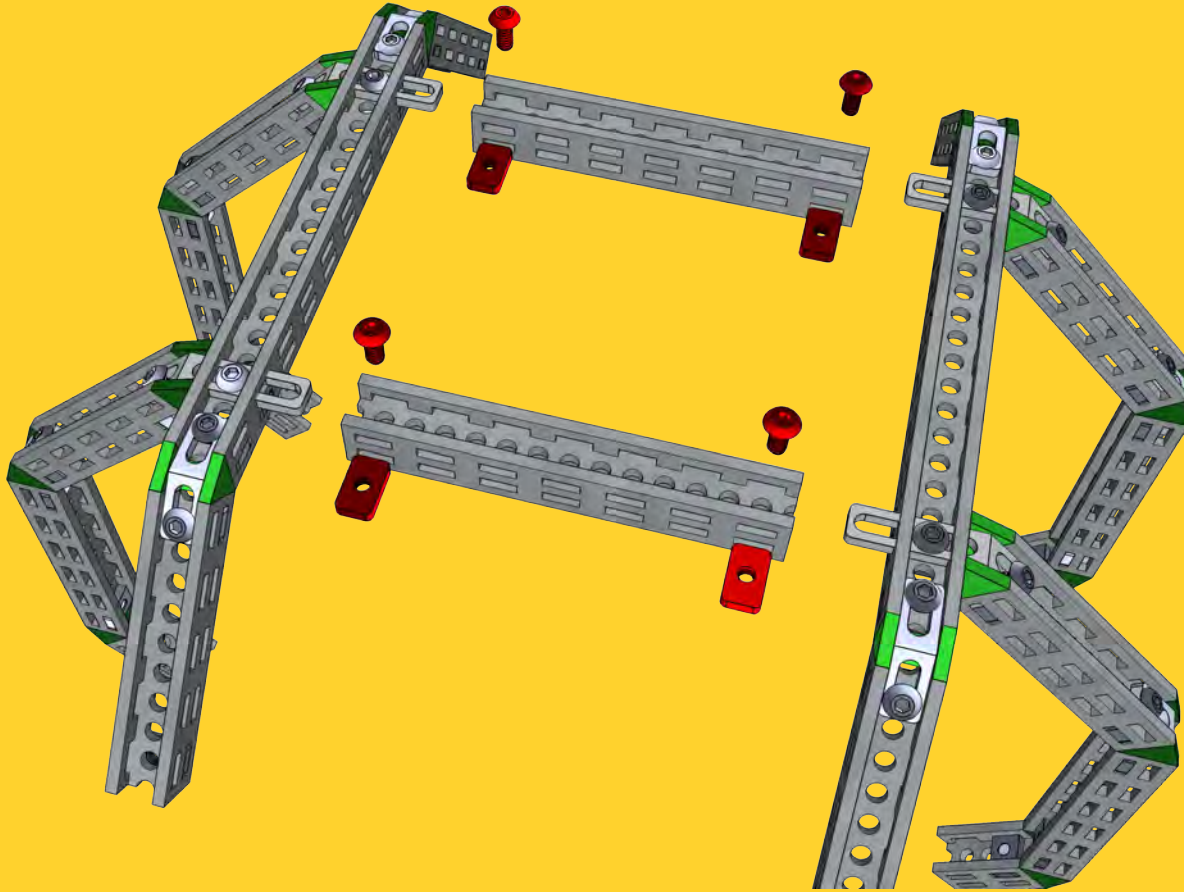

4x	4x	2x
		
M3x6 mm Bolt	Nut M3 6x10	7 cm Beam

5

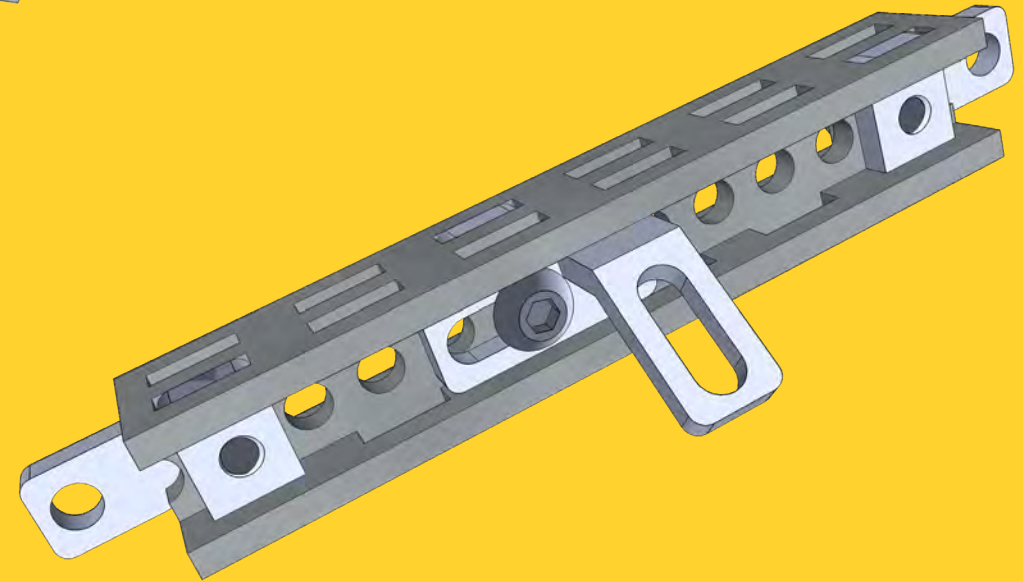
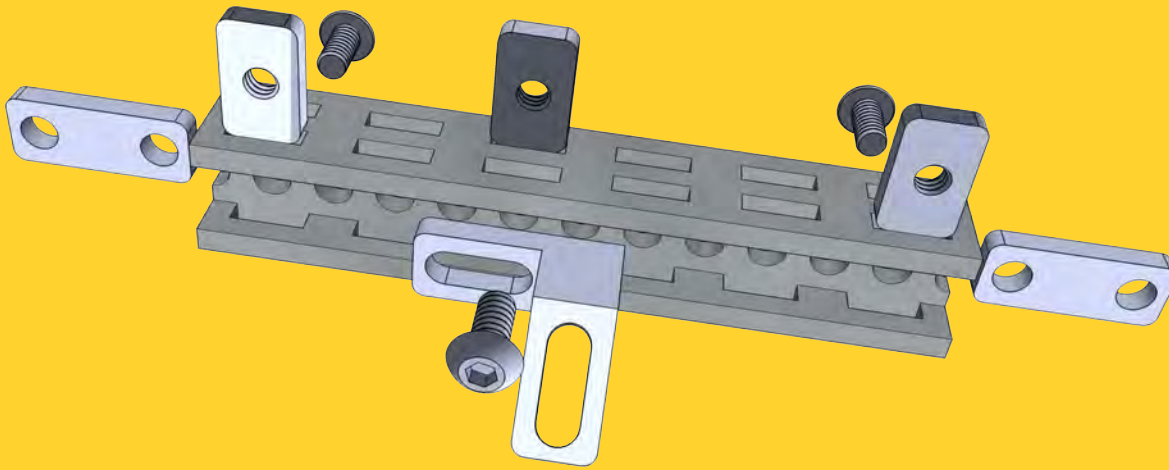

6x	6x	4x	2x	2x
				
M3x6 mm Bolt	Nut M3 6x10	2-Hole Simple Bracket	Swan 90x45	6 cm Beam

Repeat this step 2 times.

2x



4x

M3x6 mm Bolt

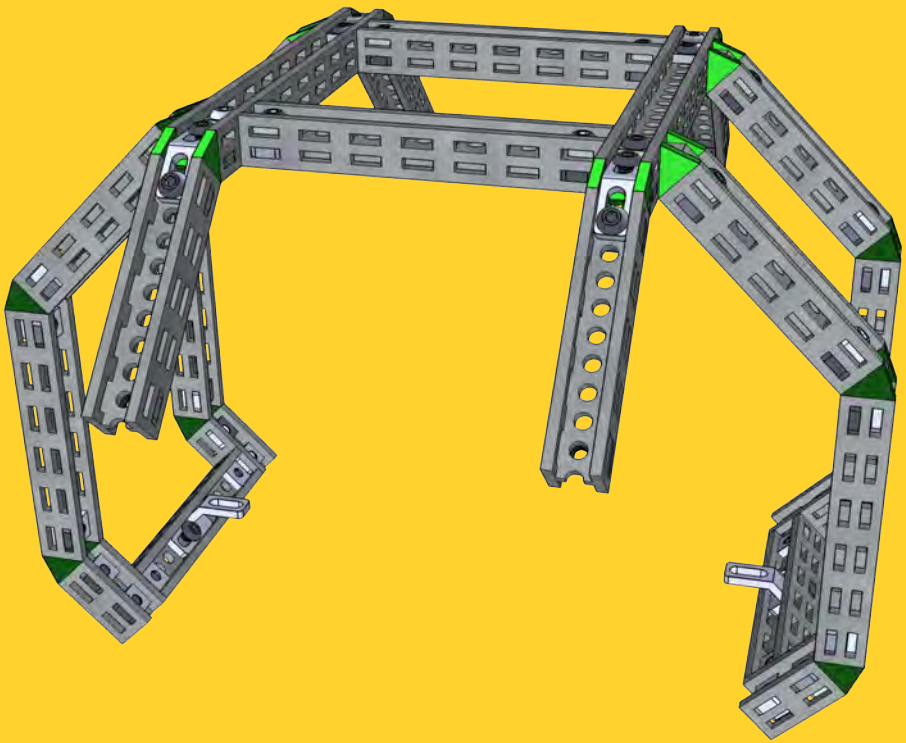
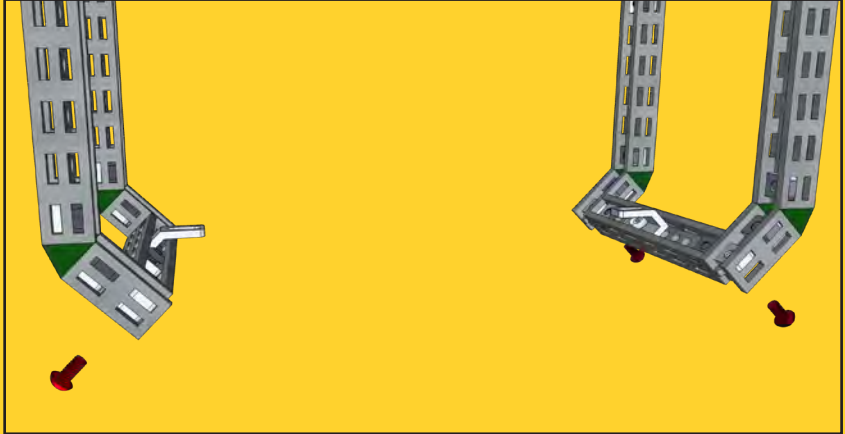
6

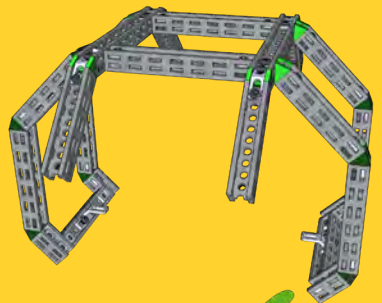

PART 11



1x 

PART 12

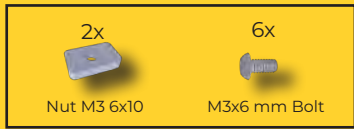
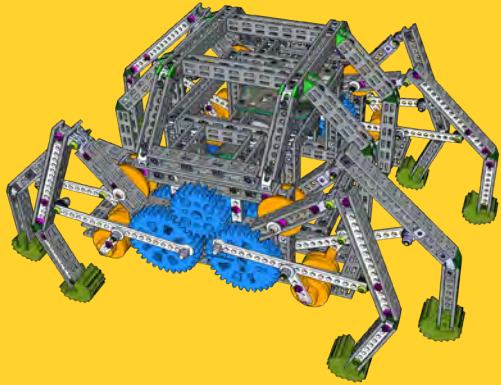

1

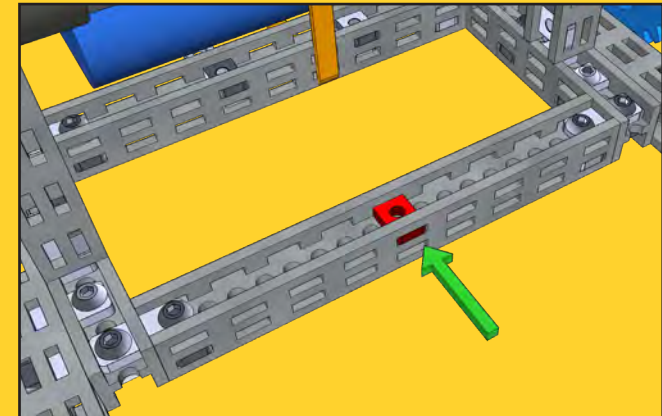
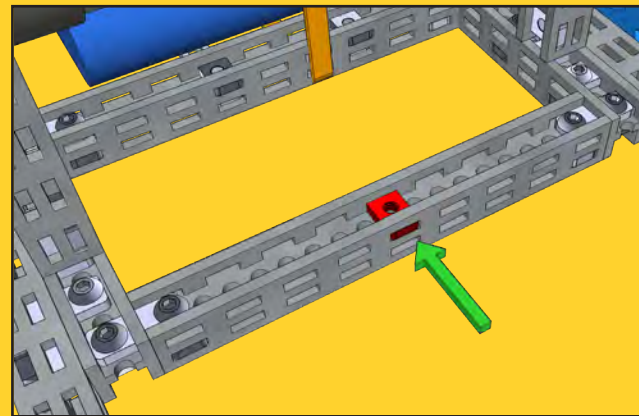
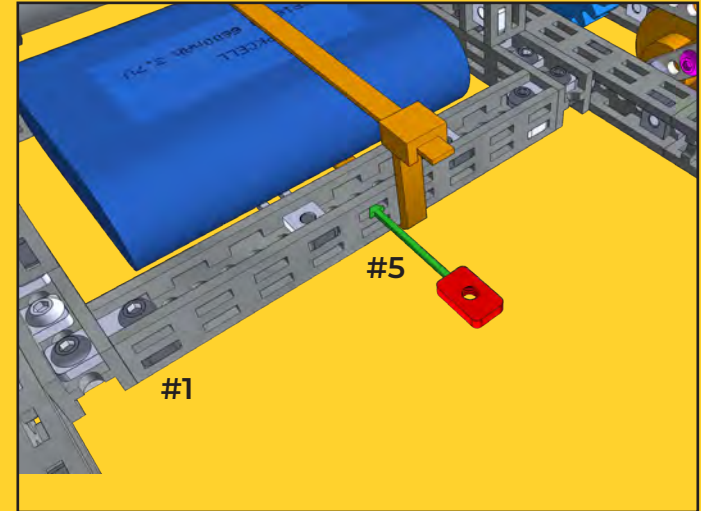
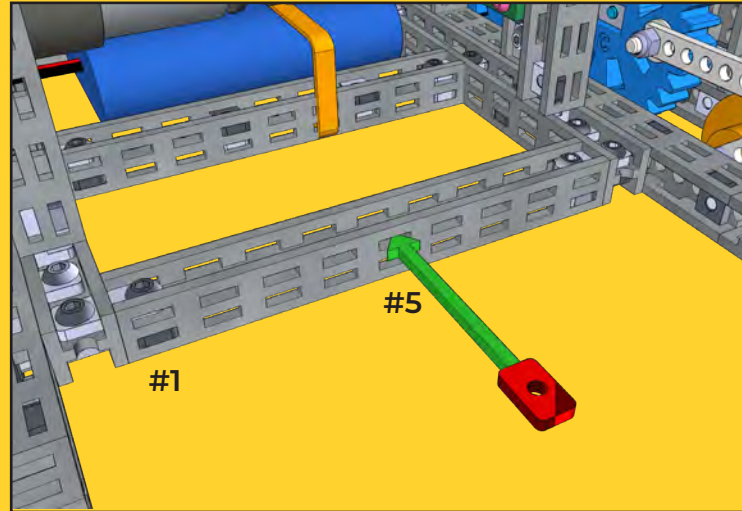

Part 11

2

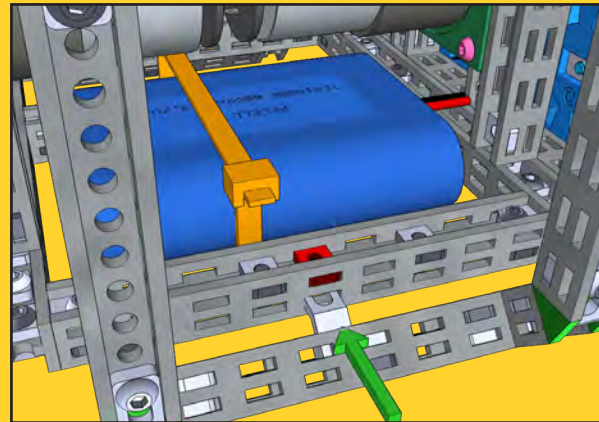
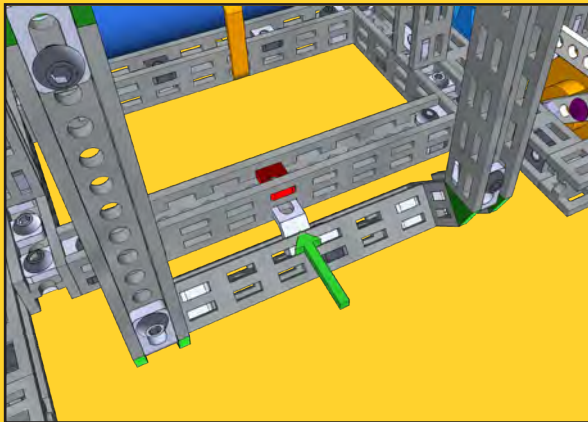
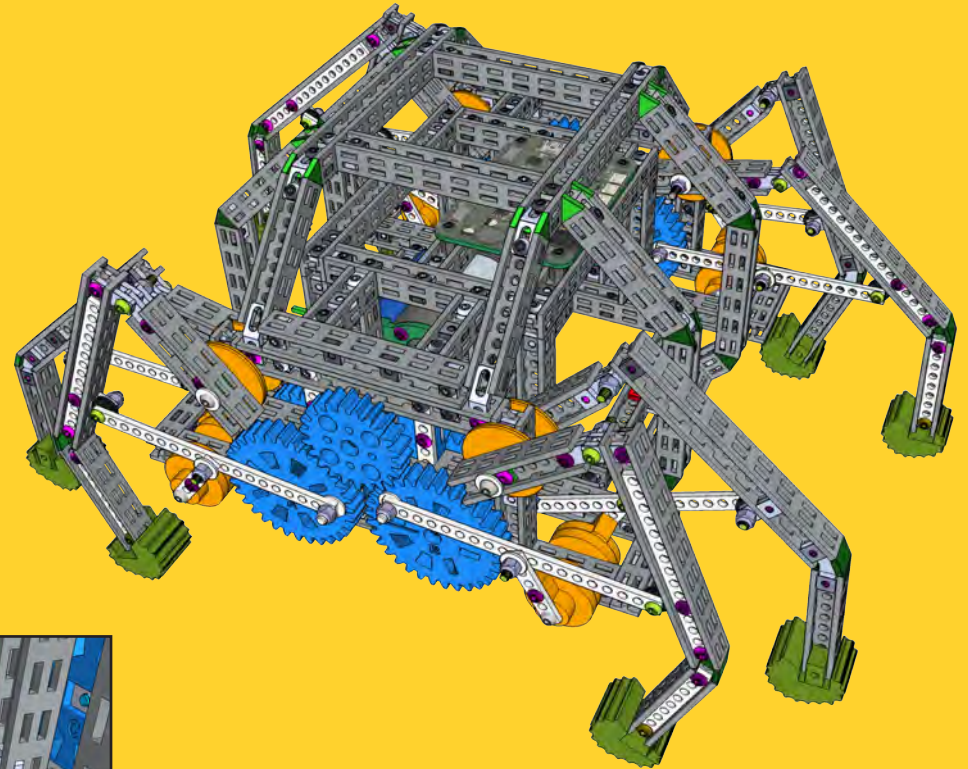
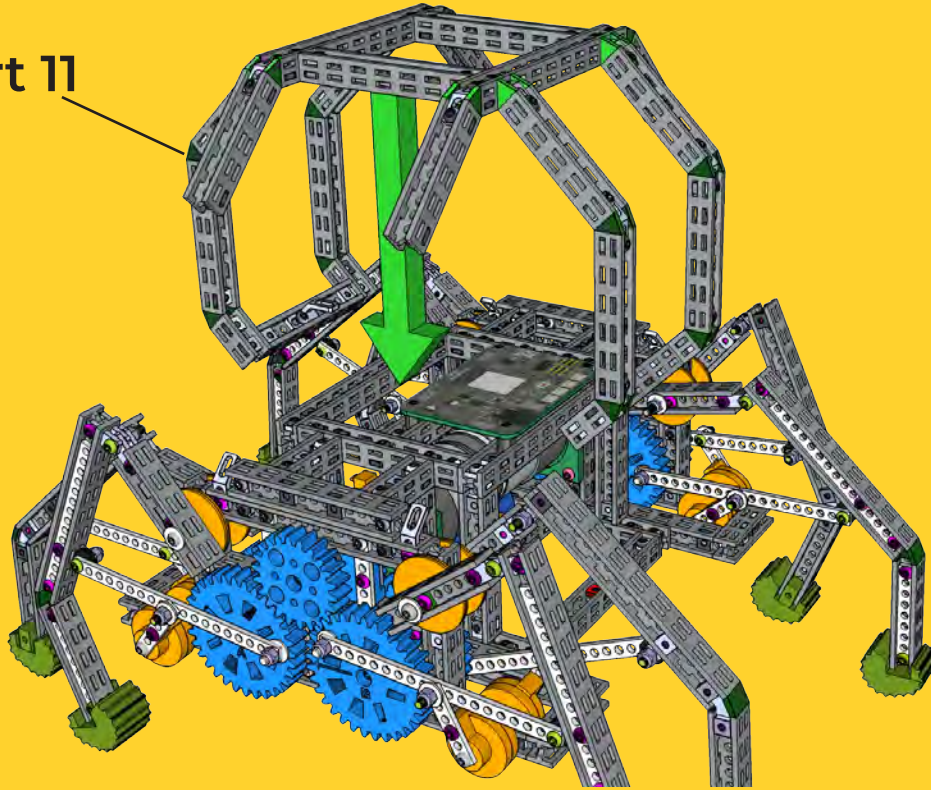

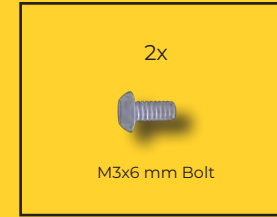
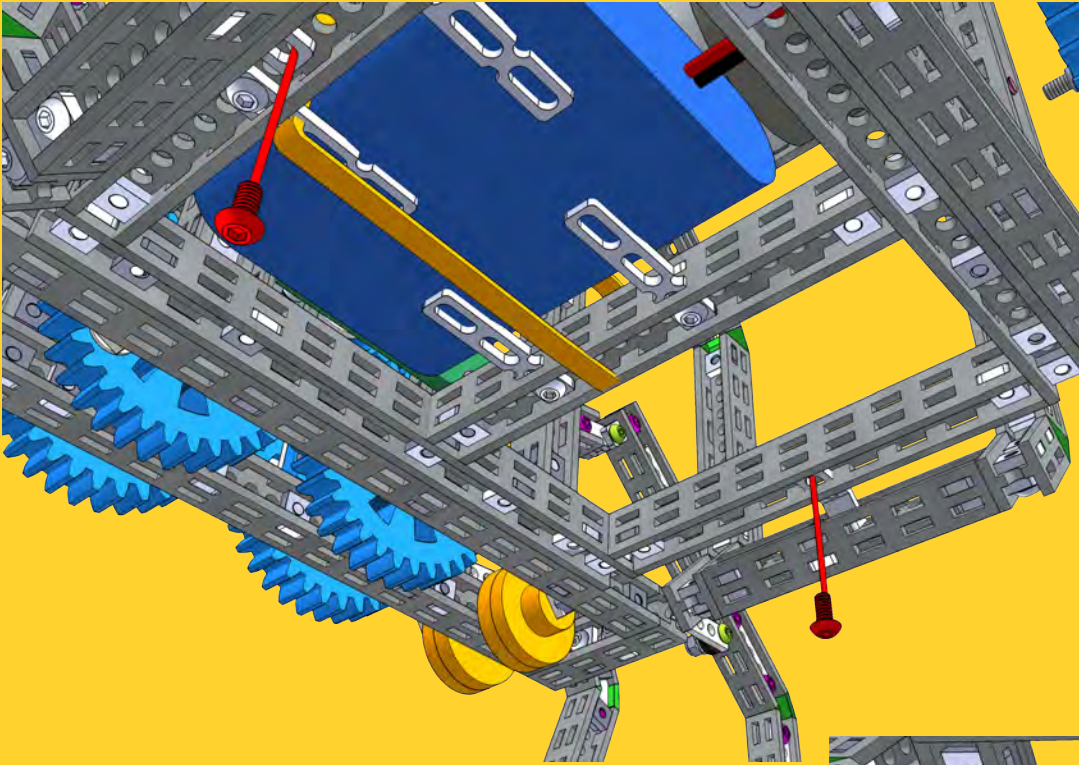

3

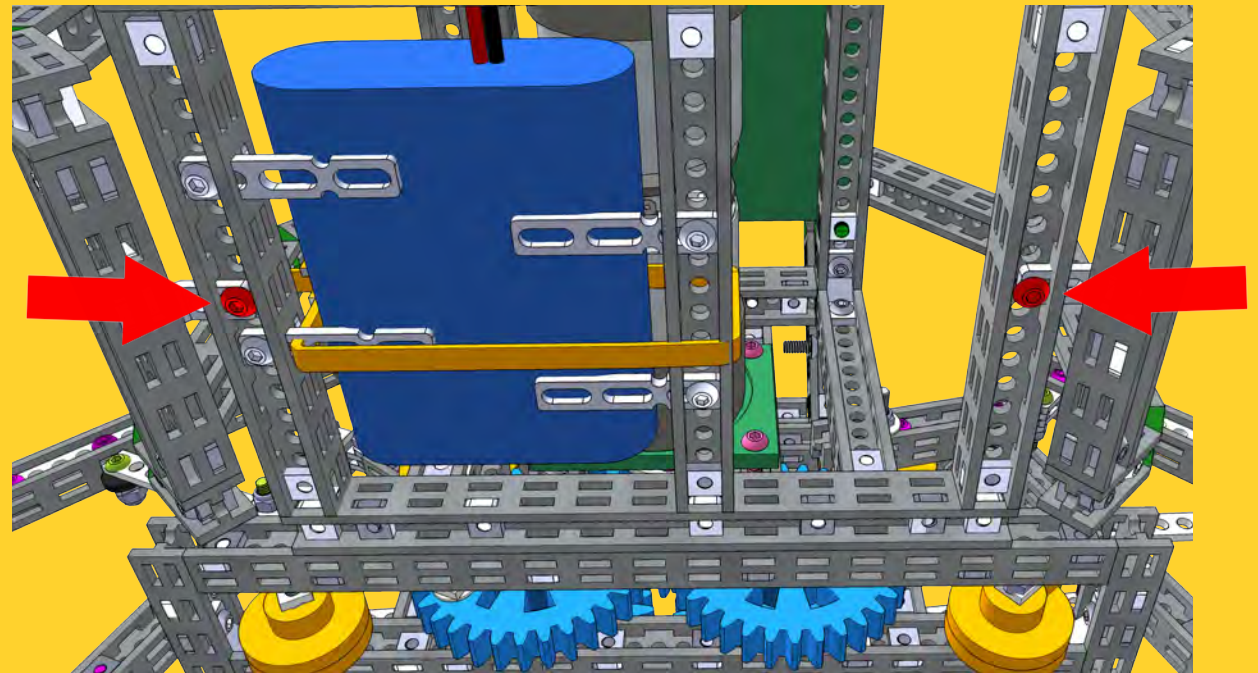

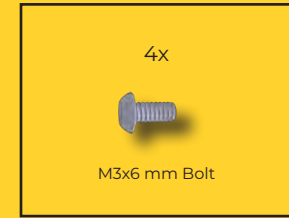

4

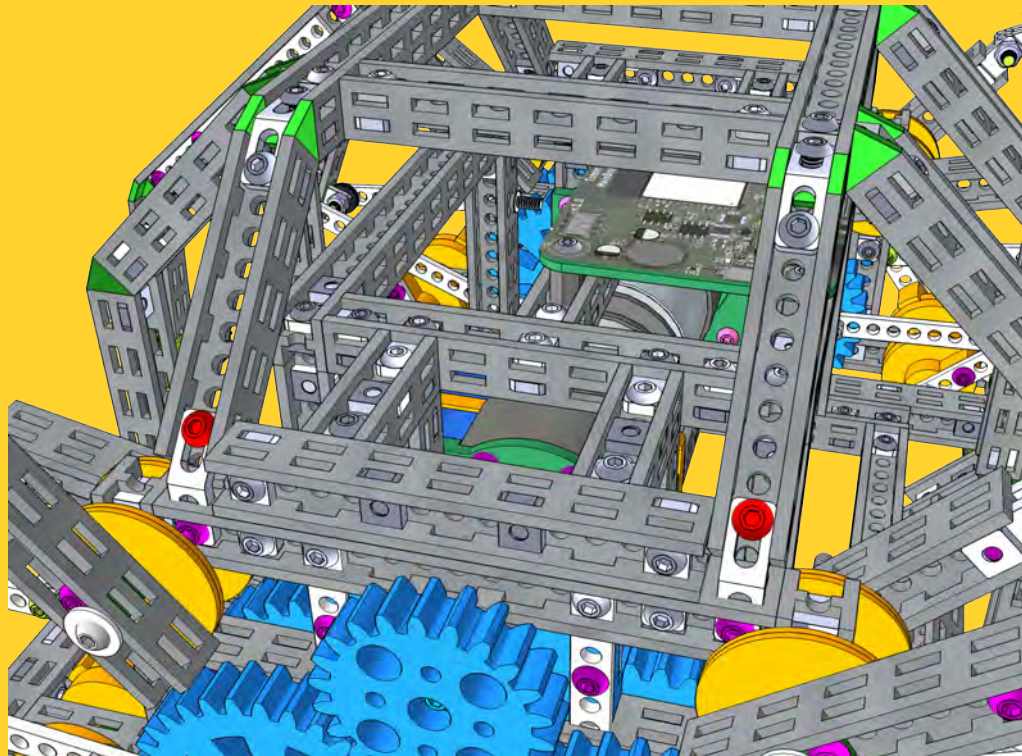

PART 12

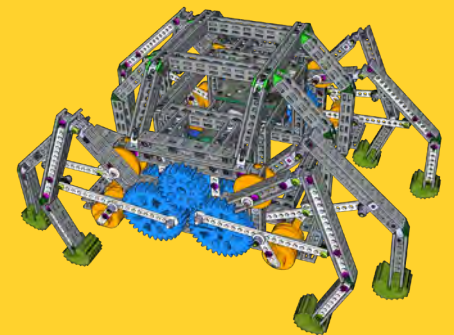

1x ✓

CONNECTING ELECTRONICS

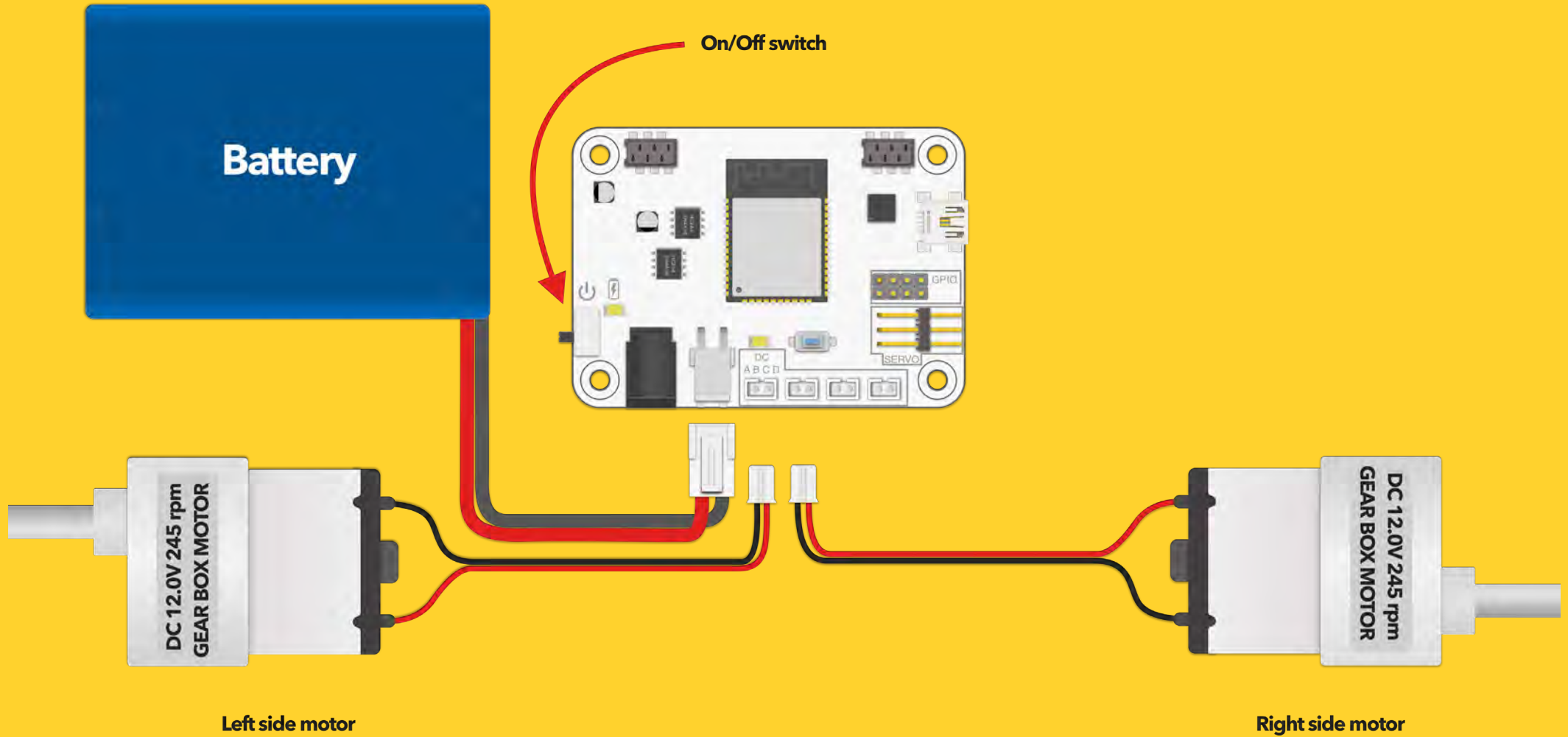

BATTERY RECHARGING

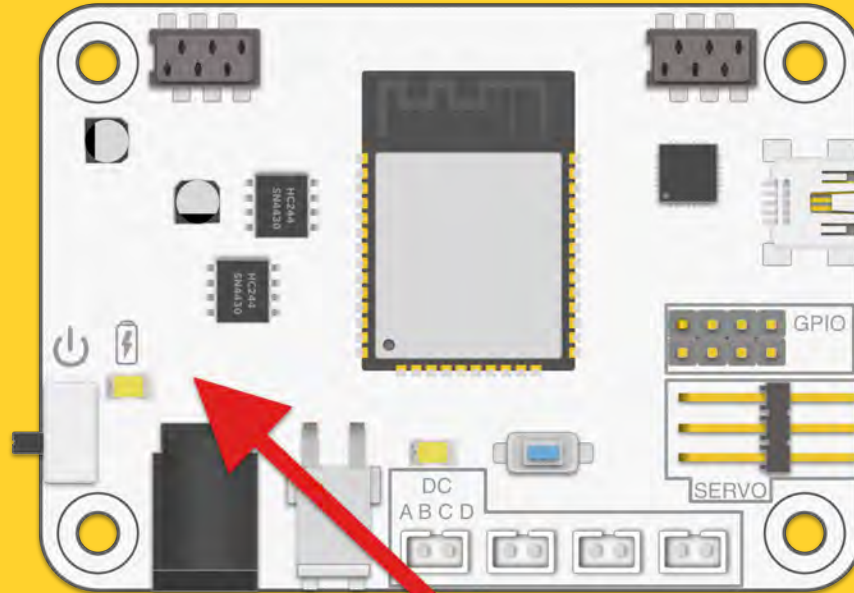

When the battery is dead, connect the power adapter to the board.

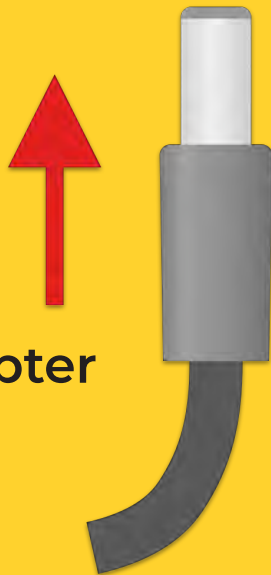

Power Adapter

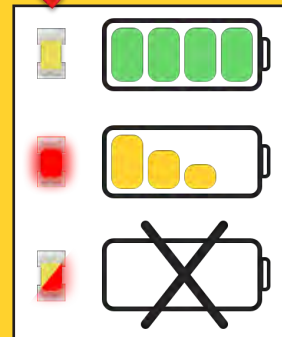

- When the LED is off, the battery is fully charged.
- When the LED is on, the battery is charging.
- When the LED is blinking, the battery is not connected.

ROBOBOARD X4

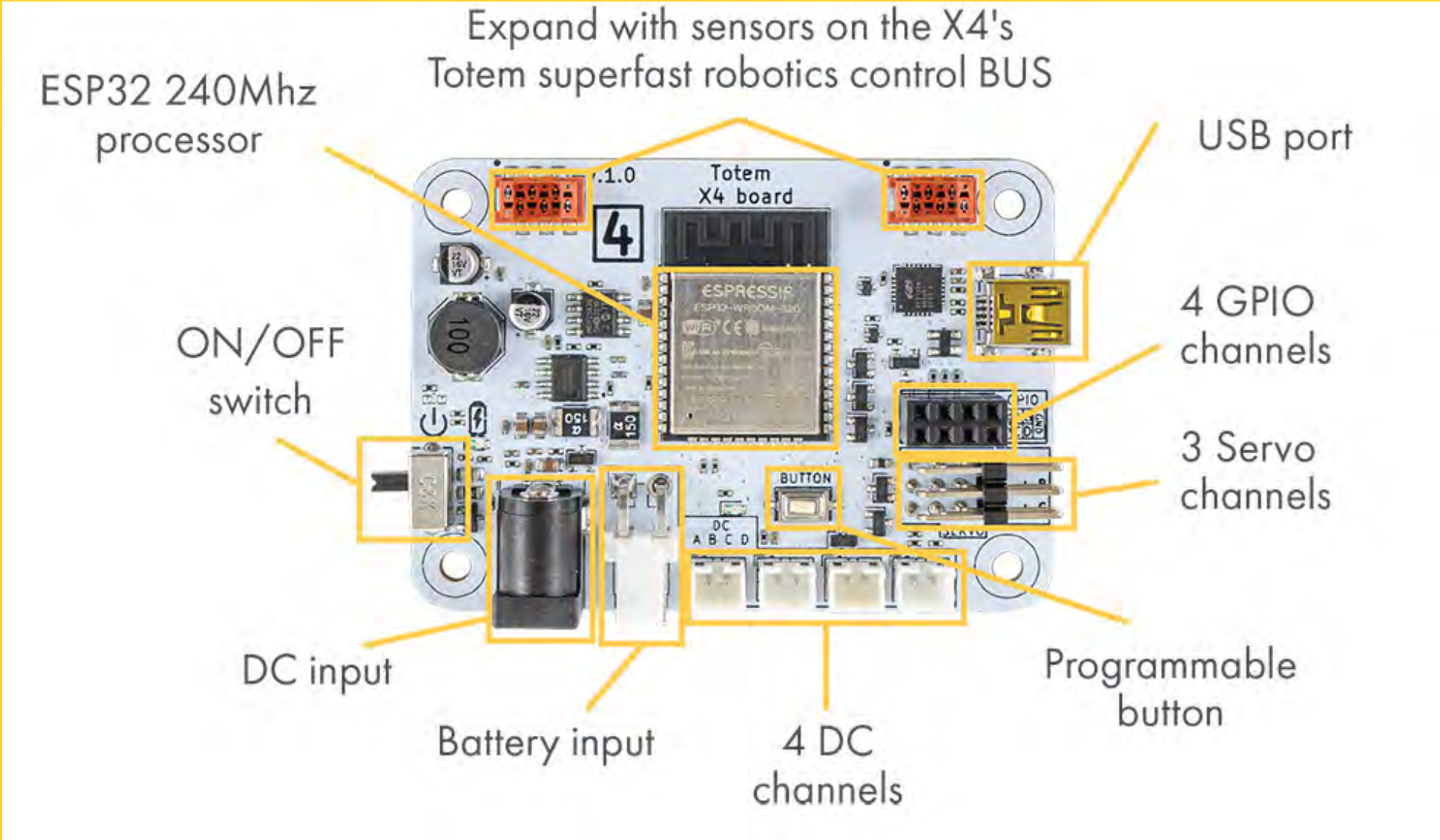



PRECAUTIONS: ELECTRONICALLY OPERATED PRODUCT

Do not give this product to children aged 8 or below. As with all electronic products, precautions should be observed during handling and use to prevent electric shock.

Adult supervision required.

CONSUMER INFORMATION

Note to adults: this is not a toy.

SAFETY WARNINGS:

- Do not pickup Black Spider while in motion.
- Keep fingers, hair, and loose clothing away from rotating legs, to avoid the injury.
- Adult supervision is required when this product is being operated.
- If you stopped operating the product, remember to unplug the battery, to avoid accidental operation.
- If the Black Spider is dirty, please clean it with dry and soft cloth. Do not clean electronics.
- Do not expose the product to high temperature, high humidity, or direct sunlight.
- Indoor use only. Do not put this product in water to avoid damaging its electronic components.
- The product is made of complex electronic circuit and electronic components, do not disassemble, or modify the circuit board.

BATTERY SAFETY INFORMATION:

- This Black Spider is designed to work with provided Totem Battery (3S Li-Ion 11.1V 2200mAh battery with JST-VH connector) and provided Totem power adapter (30W, 15V, 2A, 5.5/2.0 mm center-positive connector DC adapter).
- Rechargeable battery must be charged by adult only.
- Do not leave charging without supervision of adult.
- There is a risk of fire and personal injury if battery is punctured, damaged or misused.
- Do not disassemble or damage the battery pack.
- Use only the supplied battery. Using any other battery may damage the model.
- Use only the included power adapter to charge the battery.
- Please check on a regular basis the wire, plug, battery, charger, and other electronic parts on the product. If any damage is found, please stop using the product immediately.
- Never throw batteries into fire to avoid explosion or leakage.
- Check the batteries on regular basis to avoid leakage.
- Recycle or dispose of batteries according to local laws and guidelines.

KEEP THIS INSTRUCTION MANUAL AND THE PRODUCT BOX AS IT CONTAIN IMPORTANT INFORMATION FOR FUTURE REFERENCE.

BATTERY CHARGING:

Rechargeable battery must be charged by adult only.

- The new battery pack needs to be charged before use.
- Connect the power adapter to power source.
- The charger will show a red LED light when charging the battery. When the battery is fully charged, the red LED light turns off.

Due to the continuous product improvement, the pictures on this manual may differ slightly from the actual product. Please adhere to actual product instead.

Totem Maker names and logos are registered trademarks. All rights reserved.

www.totemmaker.net

Totem Technology, UAB

Sauletekio al. 15-709, Vilnius, 10224, Lithuania

For customer support please contact: support@totemmaker.net

