

Version: TV0.1 (Tentative)

TECHNICAL SPECIFICATION

MODEL NO:10.3inch e-Paper (D)

The content of this information is subject to be changed without notice. Please contact Waveshare for further information.

Customer's Confirmation

Customer _____

Date _____

By _____

E Ink's Confirmation

Dep	PM	PjM	FAE	Panel Design	Electronic Design	Mechanical Design	Product Verification	Prepared By
Sign								

Revision History

Rev.	Issued Date	Revised Contents
TV0.1	Feb/16,2016	Tentative

TECHNICAL SPECIFICATION

CONTENTS

<i>NO.</i>	<i>ITEM</i>	<i>PAGE</i>
-	Cover	1
-	Revision History	2
-	Contents	3
1	General Description	4
2	Features	4
3	Mechanical Specifications	
4	Mechanical Drawing of EPD module	
5	Input/Output Terminals	
6	Electrical Characteristics	
7	Power on Sequence	
8	Refresh Rate	
9	Optical Characteristics	
10	Handling, Safety and Environment Requirements and Remark	
11	Reliability test	
12	Block Diagram	
13	Packing	

1. General Description

10.3inch e-Paper (D) is a reflective electrophoretic E Ink and Mobius technology display module based on active matrix TFT substrate. It has 10.3” active area with 1404 x 1872 pixels, the display is capable to display images at 2-16 gray levels (1-4 bits) depending on the display controller and the associated waveform file it used.

2. Features

- High contrast reflective/electrophoretic technology
- 1404x 1872 Mobius display
- Ultra wide viewing angle
- Ultra low power consumption
- Pure reflective mode
- Bi-stable
- Commercial temperature range
- Landscape, portrait mode

3. Mechanical Specifications

Parameter	Specifications	Unit	Remark
Screen Size	10.3	Inch	
Display Resolution	1404(H) × 1872(V)	Pixel	
Active Area	157.248(H) × 209.664 (V)	mm	
Pixel Pitch	0.112(H) × 0.112(V)	mm	
Pixel Configuration	Rectangle		
Outline Dimension	165.8(H) × 227.70(V) × 0.647(D)	mm	
Module Weight	TBD	g	
Number of Gray	16 Gray Level (monochrome)		
Display operating mode	Reflective mode		

4. Mechanical Drawing of EPD Module

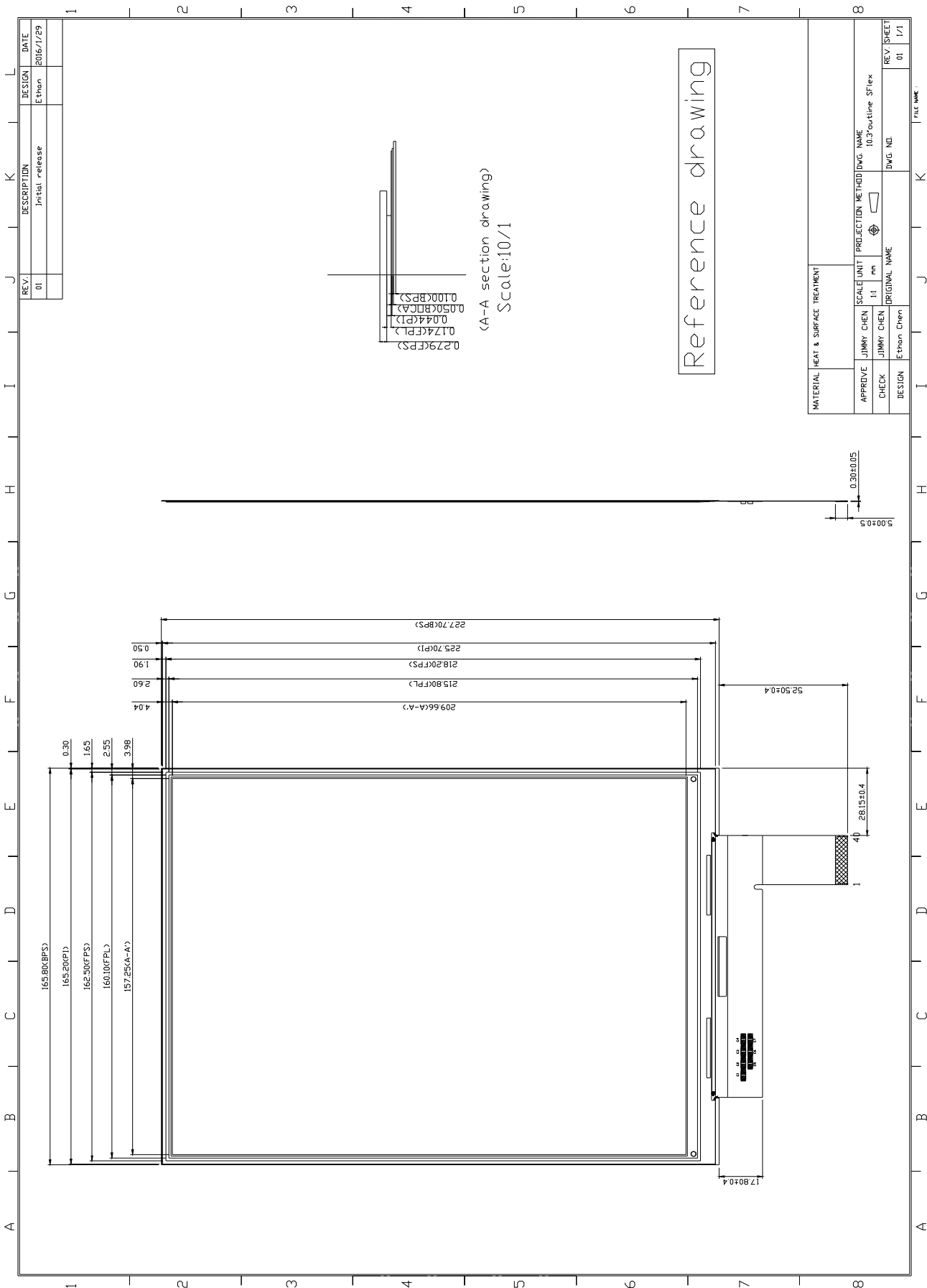

5. Input/Output Interface

5-1) Pin Assignment

Connector type : 196033-40041

Pin #	Signal	Description	Remark
1	VGL	Negative power supply gate driver	
2	NC	NO Connection	
3	VGH	Positive power supply gate driver	
4	NC	NO Connection	
5	VDD	Digital power supply drivers	
6	MODE	Output mode selection gate driver	
7	CKV	Clock gate driver	
8	SPV	Start pulse gate driver	
9	VSS	Ground	
10	VCOM	Common voltage	
11	VDD	Digital power supply drivers	
12	VSS	Ground	
13	XCL	Clock source driver	
14	D0	Data signal source driver	
15	D1	Data signal source driver	
16	D2	Data signal source driver	
17	D3	Data signal source driver	
18	D4	Data signal source driver	
19	D5	Data signal source driver	
20	D6	Data signal source driver	
21	D7	Data signal source driver	
22	VSS	Ground	
23	D8	Data signal source driver	
24	D9	Data signal source driver	
25	D10	Data signal source driver	
26	D11	Data signal source driver	
27	D12	Data signal source driver	
28	D13	Data signal source driver	
29	D14	Data signal source driver	
30	D15	Data signal source driver	
31	XSTL	Start pulse source driver	
32	XLE	Latch enable source driver	
33	XOE	Output enable source driver	
34	NC	NO Connection	
35	NC	NO Connection	
36	VPOS	Positive power supply source driver	
37	NC	NO Connection	
38	VNEG	Negative power supply source driver	
39	NC	NO Connection	
40	Border	Border connection	

5-2) Panel Scan direction

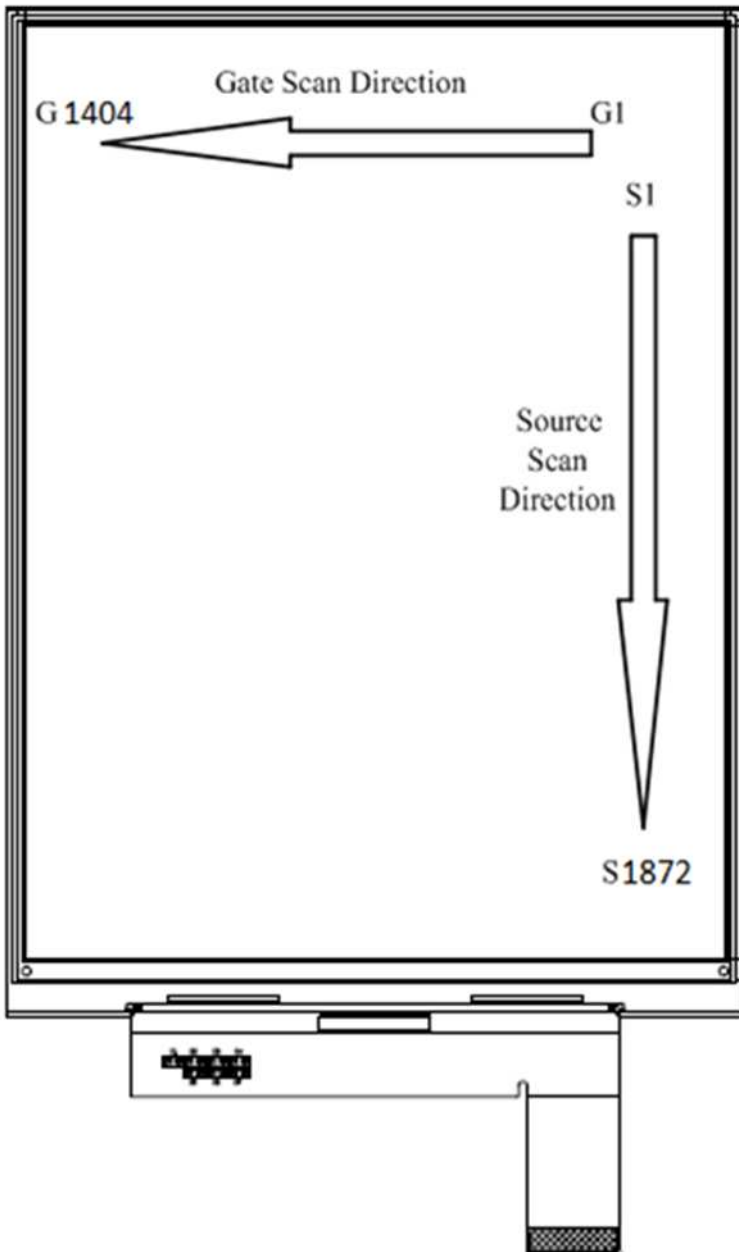

7. Electrical Characteristics

7-1) Absolute Maximum Ratings:

Parameter	Symbol	Rating	Unit	Remark
Logic Supply Voltage	V _{DD}	-0.3 to +5	V	--
Positive Supply Voltage	V _{POS}	-0.3 to +18	V	--
Negative Supply Voltage	V _{NEG}	+0.3 to -18	V	--
Max .Drive Voltage Range	V _{POS} - V _{NEG}	36	V	--
Supply Voltage	V _{GH}	-0.3 to +46	V	--
Supply Voltage	V _{GL}	-25 to +0.3	V	--
Supply Range	V _{GH} -V _{GL}	-0.3 to +46	V	--
Operating Temp. Range	TOTR	0 to +50	°C	--
Storage Temperature	TSTG	-25 to +70	°C	--

7-2) Panel DC Characteristics

Parameter	Symbol	Conditions	Min	Typ	Max	Unit
Signal ground	V _{SS}		-	0	-	V
Logic Voltage supply	V _{DD}		3.0	3.3	3.6	V
	I _{VDD}	V _{DD} =3.3V	-	TBD	-	mA
Gate Negative supply	V _{GL}		-21	-20	-19	V
	I _{GL}	V _{GL} = -20V	-	TBD	-	mA
Gate Positive supply	V _{GH}		24	25	26	V
	I _{GH}	V _{GH} = 25V	-	TBD	-	mA
Source Negative supply	V _{NEG}		-15.4	-15	-14.6	V
	I _{NEG}	V _{NEG} = -15V	-	TBD	-	mA
Source Positive supply	V _{POS}		14.6	15	15.4	V
	I _{POS}	V _{POS} = 15V	-	TBD	-	mA
Border supply	V _{COM}		-	Adjusted	-	V
Asymmetry source	V _{Asym}	V _{POS} +V _{NEG}	-800	0	800	mV
Common voltage	V _{COM}		-	Adjusted	-	V
	I _{COM}		-	TBD	-	mA
Panel Power	P		-	TBD	-	mW
Standby power panel	P _{STBY}		-	-	-	mW

- The maximum power consumption is measured using 85 Hz waveform with following pattern transition: from pattern of repeated 1 consecutive black scan lines followed by 1 consecutive white scan line to that of repeated 1 consecutive white scan lines followed by 1 consecutive black scan lines. (Note 7-1)
- The Typical power consumption is measured using 85 Hz waveform with following pattern transition: from horizontal 4 gray scale pattern to vertical 4 gray scale pattern. (Note 7-2)
- The standby power is the consumed power when the panel controller is in standby mode.

- The listed electrical/optical characteristics are only guaranteed under the controller & waveform provided by Waveshare.
- V_{com} is recommended to be set in the range of assigned value $\pm 0.1V$
- The maximum I_{COM} inrush current is about TBD mA

Note7-1

The maximum power consumption

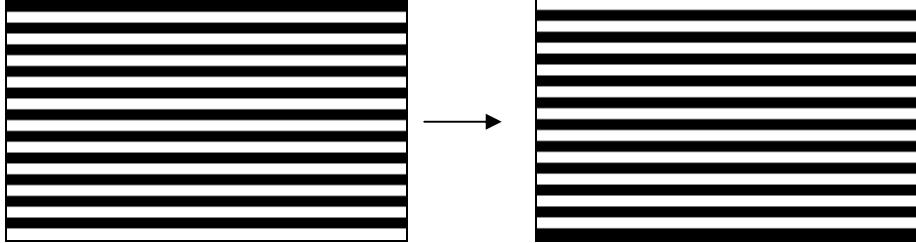

Note7-2

The typical power consumption

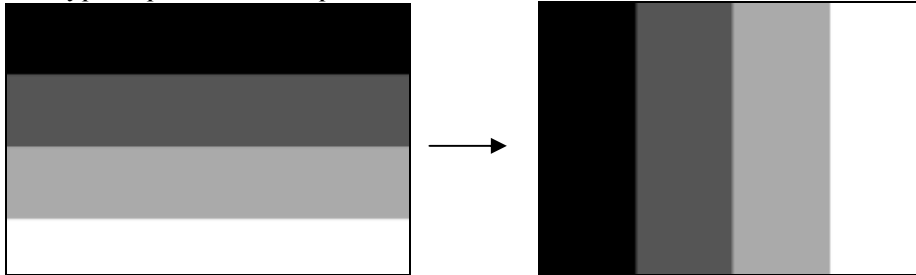

7-4) Panel AC characteristics

Parameter	Symbol	Min.	Typ.	Max.	Unit
Clock frequency	fckv	-	-	200	kHz
Minimum “L” clock pulse width	twL	0.5	-	-	us
Minimum “H” clock pulse width	twH	0.5	-	-	us
Clock rise time	trckv	-	-	100	ns
Clock fall time	tfckv	-	-	100	ns
SPV setup time	tSU	100	-	twH-100	ns
SPV hold time	tH	100	-	twH-100	ns
Pulse rise time	trspv	-	-	100	ns
Pulse fall time	tfspv	-	-	100	ns
Clock XCL cycle time	tcy	16.67	50	DC	ns
D0 .. D7 setup time	tsu	8	-	-	ns
D0 .. D7 hold time	th	8	-	-	ns
XSTL setup time	tstls	0.5*tcy	-	0.8*tcy	ns
XSTL hold time	tstlh	0.5*tcy	-	240*tcy-tstls	ns
XLE on delay time	tLEdly	3.5*tcy	-	-	ns
XLE high-level pulse width (When VDD=1.7V to 2.1V)	tLEw	300	-	-	ns
XLE off delay time	tLEoff	200	-	-	ns
Output setting time to +/- 30mV(C _{load} =200pF)	tout	-	-	20	us

OUTPUT LATCH CONTROL SIGNALS

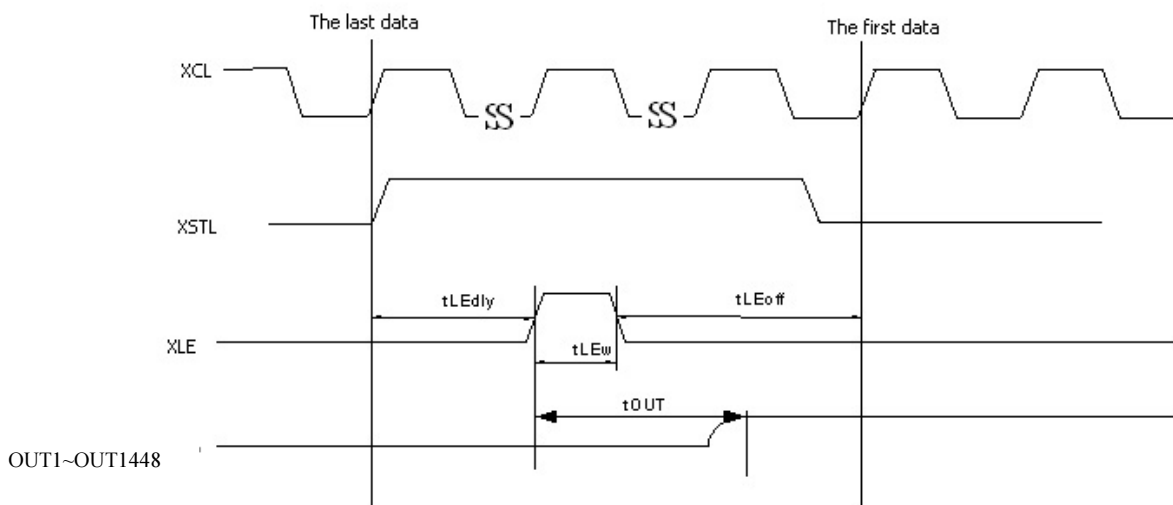

CLOCK & DATA TIMING

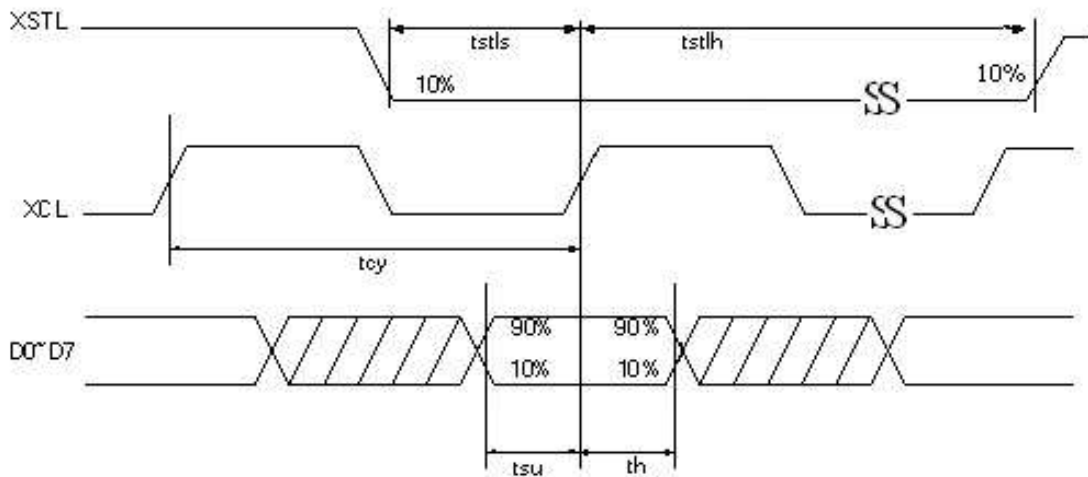

CKV & SPV TIMING

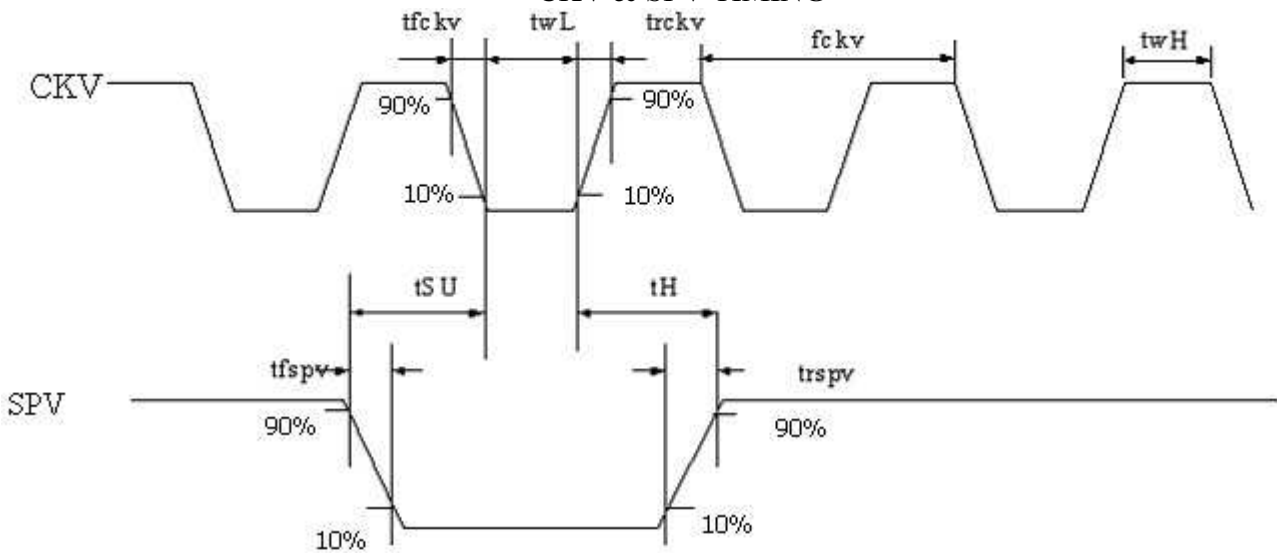

GATE OUTPUT TIMING

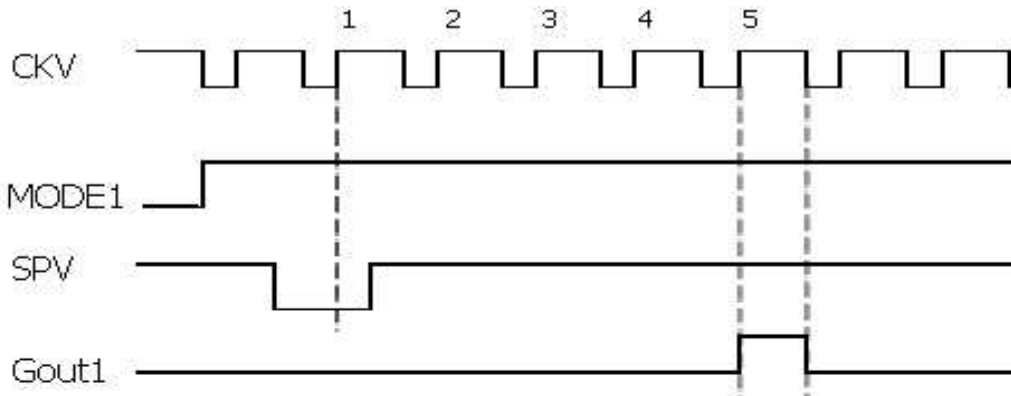

Note : First gate line on timing

7-5) Refresh Rate

The module is applied at a maximum refresh rate of 85 Hz.

	Min	Max
Refresh Rate	-	85 Hz

7-6) Controller Timing**Timing Parameters Table**

8. Power Sequence

Power Rails must be sequenced in the following order :

1. VSS → VDD → VNEG → VPOS (Source driver) → VCOM
2. VSS → VDD → VGL → VGH (Gate driver)

POWER ON

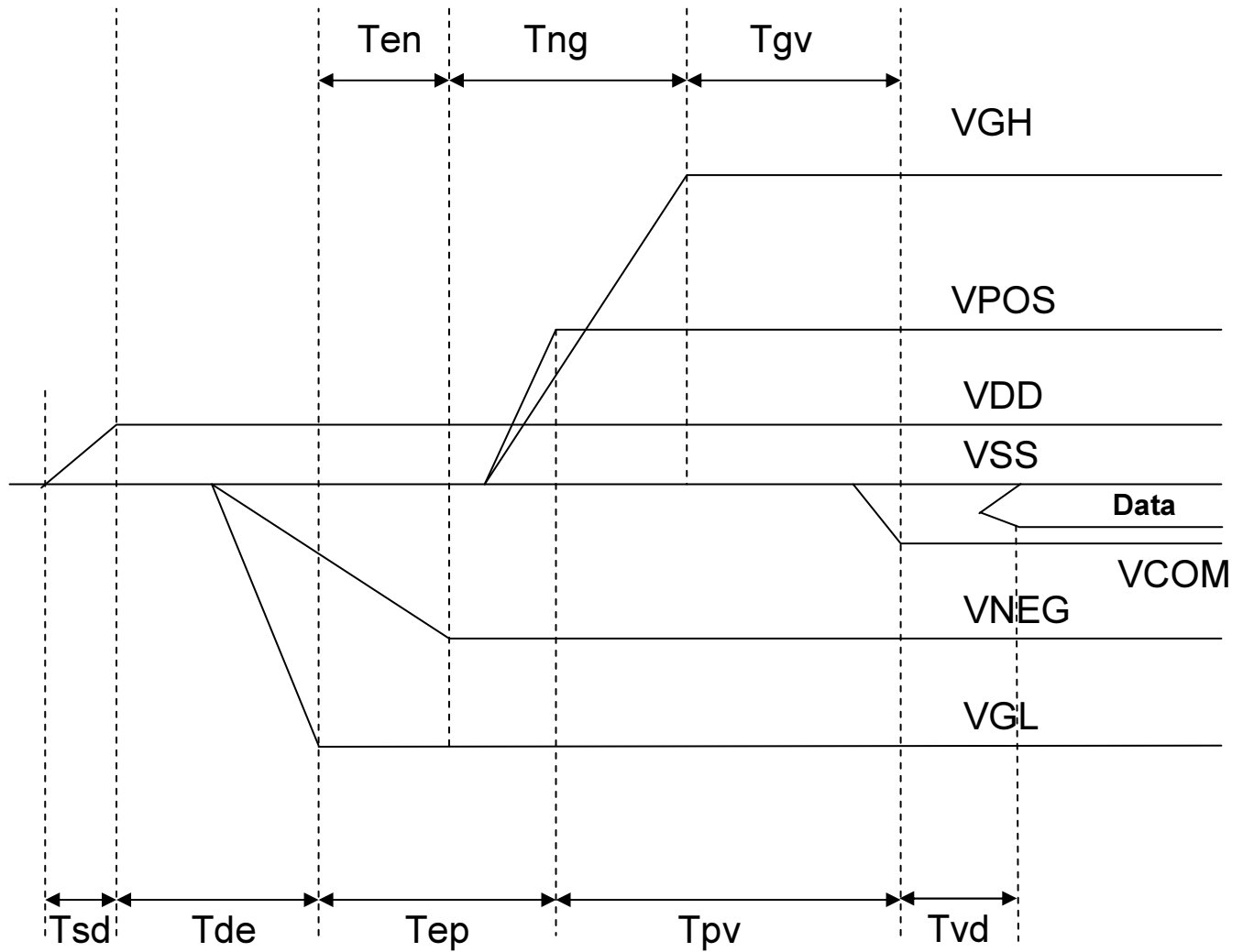

	Min	Max
Tsd	30us	-
Tde	100us	-
Tep	1000us	-
Tpv	100us	-
Tvd	100us	-
Ten	0us	-
Tng	1000us	-
Tgv	100us	-

POWER OFF

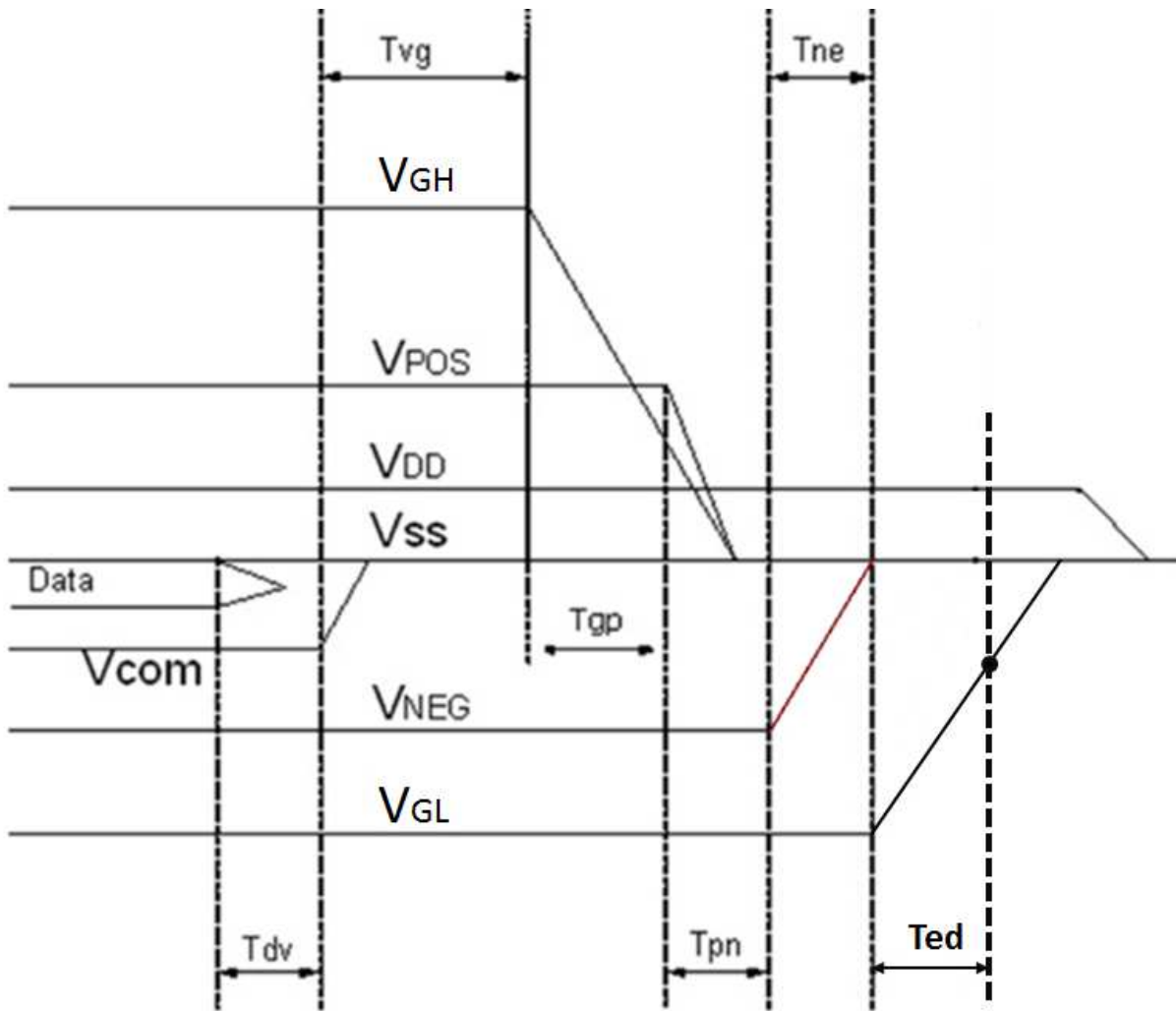

	Min	Max	Remark
Tdv	100μs	-	-
Tvg	0μs	-	-
Tgp	0μs	-	-
Tpn	0μs	-	-
Tne	0μs	-	-
Ted	0.5s	-	Discharged point @ -7.4 Volt

Note 8-1 : Supply voltages decay through pull-down resistors.

Note 8-2 : Begin to turn off VGL power after VNEG and VPOS are completely or almost discharged to GND state.

Note 8-3 : VGL must remain negative of Vcom during decay period

9. Optical characteristics

9-1) Specifications

Measurements are made by PR655 with MS-75 or equivalent SepctaScan Colorimeter with that the illumination is at an angle 45° from the perpendicular at the center of sample surface, and the detector is perpendicular unless otherwise specified.

T = 25°C

Symbol	Parameter	Conditions		Min	Typ.	Max	Unit	Note	
R	Reflectance	White	Front Light off	TBD	TBD	-	%	Note 9-1	
Gn	N th Grey	-		-	-	DS+(WS-DS) ⁿ / (m-1)	-	L*	-
	Level								
CR	Contrast Ratio	-		TBD	TBD	-	-	Note 9-2	

WS: White state , DS: Dark state, Gray state from Dark to White :DS 、 G1 、 G2... 、 Gn... 、 Gm-2 、 WS
m:4 、 8 、 16 when 2 、 3 、 4 bits mode

9-2) Definition of contrast ratio

The contrast ratio (CR) is the ratio between the reflectance in a full white area (Rl) and the reflectance in a dark area (Rd):

$$CR = Rl/Rd$$

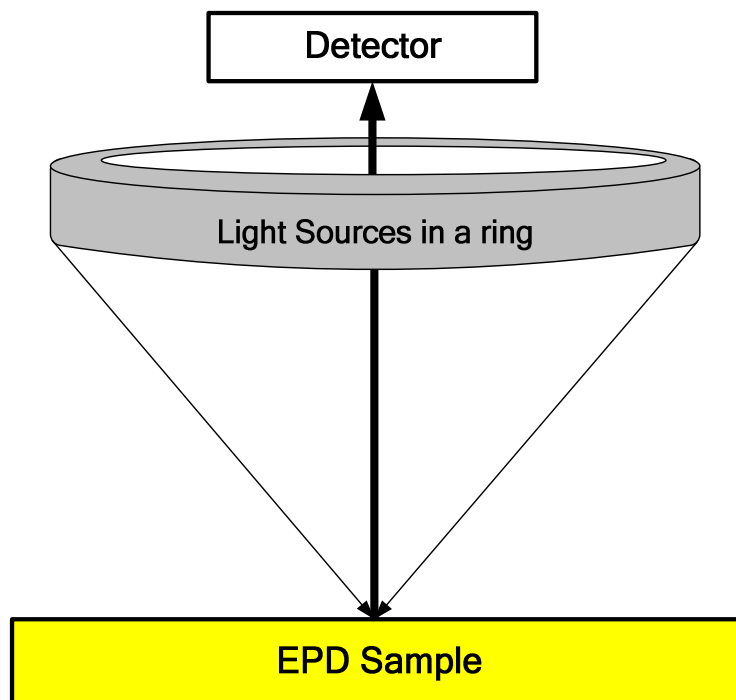

9-3) Reflection Ratio

The reflection ratio is expressed as:

$$R = \text{Reflectance Factor}_{\text{white board}} \times (L_{\text{center}} / L_{\text{white board}})$$

L_{center} is the luminance measured at center in a white area ($R=G=B=1$). $L_{\text{white board}}$ is the luminance of a standard white board. Both are measured with equivalent illumination source. The viewing angle shall be no more than 2 degrees.

10. HANDLING, SAFETY AND ENVIROMENTAL REQUIREMENTS AND REMARK

WARNING
The display glass may break when it is dropped or bumped on a hard surface. Handle with care. Should the display break, do not touch the electrophoretic material. In case of contact with electrophoretic material, wash with water and soap.

CAUTION
The display module should not be exposed to harmful gases, such as acid and alkali gases, which corrode electronic components.
Disassembling the display module can cause permanent damage and invalidate the warranty agreements.
IPA solvent can only be applied on active area and the back of a glass. For the rest part, it is not allowed.

Mounting Precautions
(1) It's recommended that you consider the mounting structure so that uneven force (ex. Twisted stress) is not applied to the module.
(2) It's recommended that you attach a transparent protective plate to the surface in order to protect the EPD. Transparent protective plate should have sufficient strength in order to resist external force.
(3) You should adopt radiation structure to satisfy the temperature specification.
(4) Acetic acid type and chlorine type materials for the cover case are not desirable because the former generates corrosive gas of attacking the PS at high temperature and the latter causes circuit break by electro-chemical reaction.
(5) Do not touch, push or rub the exposed PS with glass, tweezers or anything harder than HB pencil lead. And please do not rub with dust clothes with chemical treatment. Do not touch the surface of PS for bare hand or greasy cloth. (Some cosmetics deteriorate the PS)
(6) When the surface becomes dusty, please wipe gently with absorbent cotton or other soft materials like chamois soaks with petroleum benzene. Normal-hexane is recommended for cleaning the adhesives used to attach the PS. Do not use acetone, toluene and alcohol because they cause chemical damage to the PS.
(7) Wipe off saliva or water drops as soon as possible. Their long time contact with PS causes deformations and color fading.

Data sheet status	
Product specification	This data sheet contains preliminary product specifications.
Limiting values	
<p>Limiting values given are in accordance with the Absolute Maximum Rating System (IEC 134). Stress above one or more of the limiting values may cause permanent damage to the device. These are stress ratings only and operation of the device at these or at any other conditions above those given in the Characteristics sections of the specification is not implied. Exposure to limiting values for extended periods may affect device reliability.</p>	
Application information	
Where application information is given, it is advisory and does not form part of the specification.	

REMARK
<p>All The specifications listed in this document are guaranteed for module only. Post-assembled operation or component(s) may impact module performance or cause unexpected effect or damage and therefore listed specifications is not warranted after any Post-assembled operation.</p>

11. Reliability test

TBD

12. Block Diagram

TBD

13.Packing

TBD