

**Xgt ukqp<'3Q"**

**VGEJ P K E C N'URGE K H E C V I Q P "**

**O Q F G N'P Q<'7.8inch e-Paper**

The content of this information is subject to be changed without notice. Please contact Waveshare or its agent for further information.

Customer's Confirmation

Customer

Date

By

## Revision History

<b>Rev.</b>	<b>Issued Date</b>	<b>Revised Contents</b>
1.0	Apr 19, 2018	New

# ***TECHNICAL SPECIFICATION***

## **CONTENTS**

1.	General Description.....	1
2.	Features.....	1
3.	Mechanical Specifications.....	1
4.	Mechanical Drawing of EPD Module .....	2
5.	Input / Output Interface .....	3
6.	Display Module Electrical Characteristics .....	5
7.	Power Sequence.....	11
8.	Optical Characteristics.....	13
9.	Handling, Safety and Environmental Requirements and Remark .....	15
10.	Border Definition.....	17
11.	Block Diagram.....	18
12.	Packing .....	19

## 1. General Description

7.8inch e-Paper is a reflective electrophoretic E Ink technology display module based on active matrix TFT substrate featuring capacitive touch panel with front light. It has 7.8" active area with 1404 x 1872 pixels, the display is capable to display images at 2-16 grey levels (1-4 bits) depending on the display controller and the associated waveform file it used.

## 2. Features

- Carta high contrast reflective/electrophoretic technology
- 1404 x 1872 resolution
- Ultra wide viewing angle
- Ultra low power consumption
- Pure reflective mode
- Bi-stable
- Commercial temperature range
- Landscape, portrait mode

## 3. Mechanical Specifications

Parameter	Specifications	Unit	Remark
Screen Size	7.8 (3:4)	Inch	
Display Resolution	1404 (H)×1872 (V)	Pixel	
Active Area	118.638 (H)×158.184 (V)	mm	
Pixel Pitch	0.0845 (H)×0.0845 (V)	mm	
Pixel Configuration	Square		
Outline Dimension	127.6(H) * 173.8(V) * 0.78(D) (EPD w/o FPC)	mm	
Module Weight	36.9 ± 5	g	
Number of Grey	16 Grey Level (monochrome)		
Display operating mode	Reflective mode		

**4. Mechanical Drawing of EPD Module**

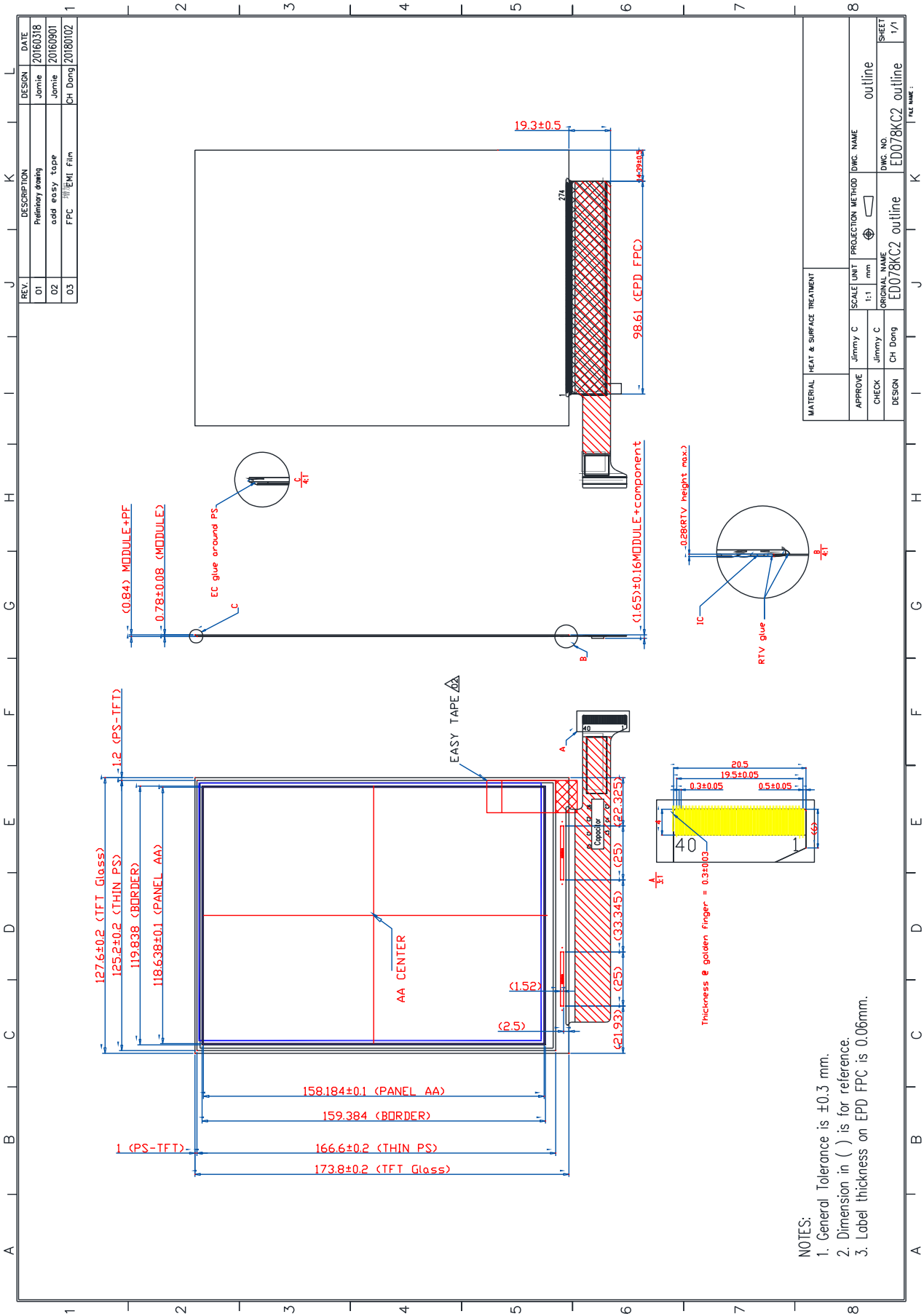

## 5. Input / Output Interface

### 5.1 Connector type

P-TWO INDUSTRIES INC 196033-40041-1

#### 5.1.1 Pin assignment

Pin #	Signal	Description
1	VGL	Negative power supply gate driver
2	NC	NO Connection
3	VGH	Positive power supply gate driver
4	NC	NO Connection
5	VDD	Digital power supply drivers
6	Mode	Output mode selection gate driver
7	CKV	Clock gate driver
8	SPV	Start pulse gate driver
9	VSS	Ground
10	VCOM	Common voltage
11	VDD	Digital power supply drivers
12	VSS	Ground
13	XCL	Clock source driver
14	D0	Data signal source driver
15	D1	Data signal source driver
16	D2	Data signal source driver
17	D3	Data signal source driver
18	D4	Data signal source driver
19	D5	Data signal source driver
20	D6	Data signal source driver
21	D7	Data signal source driver
22	VSS	Ground
23	D8	Data signal source driver
24	D9	Data signal source driver
25	D10	Data signal source driver
26	D11	Data signal source driver
27	D12	Data signal source driver
28	D13	Data signal source driver
29	D14	Data signal source driver
30	D15	Data signal source driver
31	XSTL	Start pulse source driver
32	XLE	Latch enable source driver
33	XOE	Output enable source driver
34	TEST	E Ink internal test pin (Note 1)
35	NC	NO Connection
36	VPOS	Positive power supply source driver
37	NC	NO Connection
38	VNEG	Negative power supply source driver
39	NC	NO Connection
40	Border	Border connection

Note 1: Please connect to VDD voltage.

## 5.2 Panel Scan Direction

Gate Scan Direction

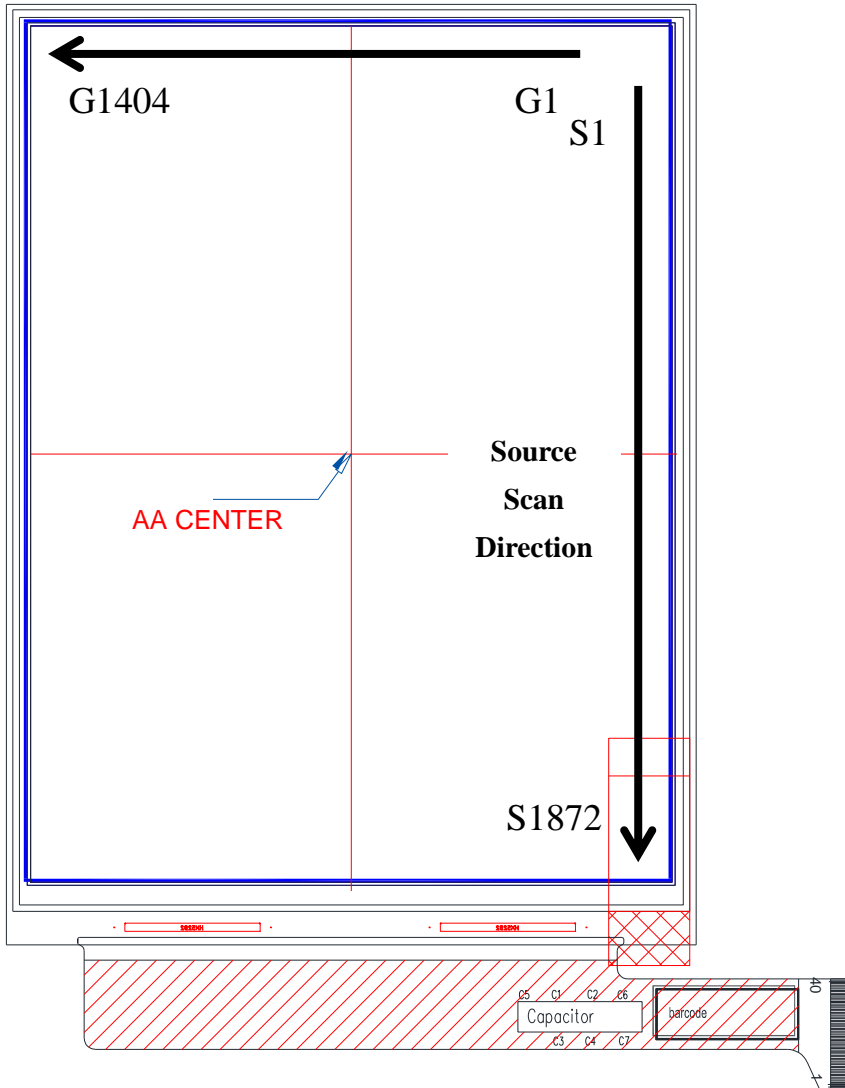

## 6. Display Module Electrical Characteristics

### 6.1 Absolute Maximum Ratings

Parameter	Symbol	Rating	Unit	Remark
Logic Supply Voltage	VDD	-0.3 to +5	V	--
Positive Supply Voltage	V <sub>POS</sub>	-0.3 to +18	V	--
Negative Supply Voltage	V <sub>NEG</sub>	+0.3 to -18	V	--
Max .Drive Voltage Range	V <sub>POS</sub> - V <sub>NEG</sub>	36	V	--
Supply Voltage	VGH	-0.3 to VGL+50	V	--
Supply Voltage	VGL	-25 to +0.3	V	--
Supply Range	VGH-VGL	+10 to +50	V	--
Operating Temp. Range	TOTR	0 to +50	°C	--
Storage Temperature	TSTG	-25 to +70	°C	--

### 6.2 Display Module DC Characteristics

Parameter	Symbol	Conditions	Min	Typ	Max	Unit
Signal ground	V <sub>SS</sub>		-	0	-	V
Logic Voltage supply	V <sub>DD</sub>		3.0	3.3	3.6	V
	I <sub>VDD</sub>	V <sub>DD</sub> =3.3V	-	12	15	mA
Gate Negative supply	V <sub>GL</sub>		-21	-20	-19	V
	I <sub>GL</sub>	V <sub>GL</sub> = -20V	-	2	20	mA
Gate Positive supply	V <sub>GH</sub>		24	25	26	V
	I <sub>GH</sub>	V <sub>GH</sub> = 25V	-	1	5	mA
Source Negative supply	V <sub>NEG</sub>		-15.4	-15	-14.6	V
	I <sub>NEG</sub>	V <sub>NEG</sub> = -15V	-	2	200	mA
Source Positive supply	V <sub>POS</sub>		14.6	15	15.4	V
	I <sub>POS</sub>	V <sub>POS</sub> = 15V	-	2	200	mA
Border supply	V <sub>COM</sub>		-	Adjusted	-	V
Asymmetry source	V <sub>Asym</sub>	V <sub>POS</sub> +V <sub>NEG</sub>	-800	0	800	mV
Common voltage	V <sub>COM</sub>		-4	Adjusted	-0.3	V
	I <sub>COM</sub>		-	0.2	-	mA
Panel Power	P		-	164.6	6574.5	mW
Standby power panel	P <sub>STBY</sub>		-	-	0.17	mW

- The maximum power consumption is measured using 85Hz waveform with following pattern transition: from pattern of repeated 1 consecutive black scan lines followed by 1 consecutive white scan line to that of repeated 1 consecutive white scan lines followed by 1 consecutive black scan lines (Note 6-1).
- The Typical power consumption is measured using 85Hz waveform with following pattern transition: from horizontal 4 grey scale pattern to vertical 4 grey scale patterns (Note 6-2).



- The standby power is the consumed power when the panel controller is in standby mode.
- The listed electrical/optical characteristics are only guaranteed under the controller & waveform provided by Waveshare.
- Vcom is recommended to be set in the range of assigned value  $\pm 0.1V$
- The maximum  $I_{COM}$  inrush current is about 1500 mA

Note 6-1

The maximum power consumption

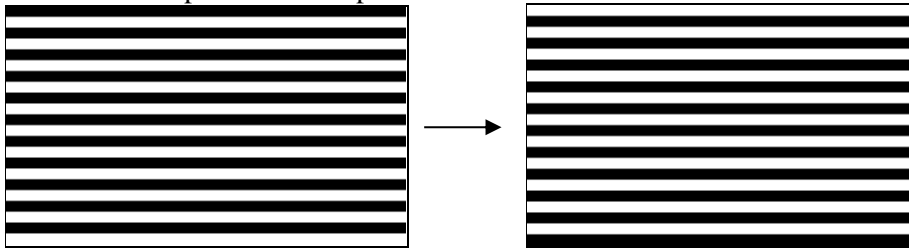

Note 6-2

The typical power consumption

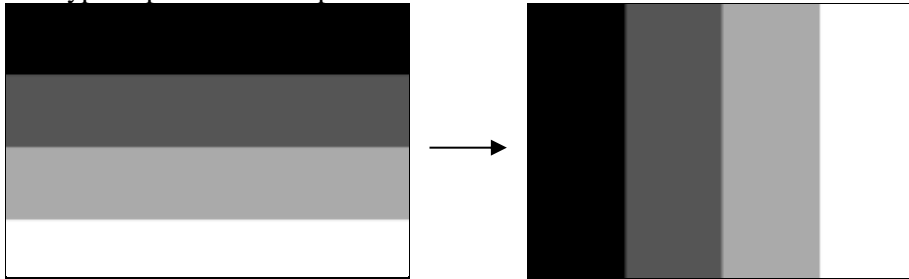

### 6.3 Display Module AC characteristics

Parameter	Symbol	Min.	Typ.	Max.	Unit
Clock frequency	fckv	-	-	200	kHz
Minimum “L” clock pulse width	twL	500	-	-	ns
Minimum “H” clock pulse width	twH	500	-	-	ns
Clock rise time	trckv	-	-	100	ns
Clock fall time	tfckv	-	-	100	ns
SPV setup time	tSU	100	-	-	ns
SPV hold time	tH	100	-	-	ns
Pulse rise time	trspv	-	-	100	ns
Pulse fall time	tfspv	-	-	100	ns
Clock XCL cycle time	tcy	16.67	50	-	ns
D0 .. D15 setup time	tsu	8	-	-	ns
D0 .. D15 hold time	th	8	-	-	ns
XSTL setup time	tstls	0.5*tcy	-	0.8*tcy	ns
XSTL hold time	tstlh	0.5*tcy	-	240*tcy-tstls	ns
XLE on delay time	tLEdly	10.5*tcy	-	-	ns
XLE high-level pulse width (When VDD=3.0V to 3.6V)	tLEw	300	-	-	ns
XLE off delay time	tLEoff	200	-	-	ns
Output setting time to +/- 30mV(C <sub>load</sub> =200pF)	tout	-	-	20	us

#### OUTPUT LATCH CONTROL SIGNALS

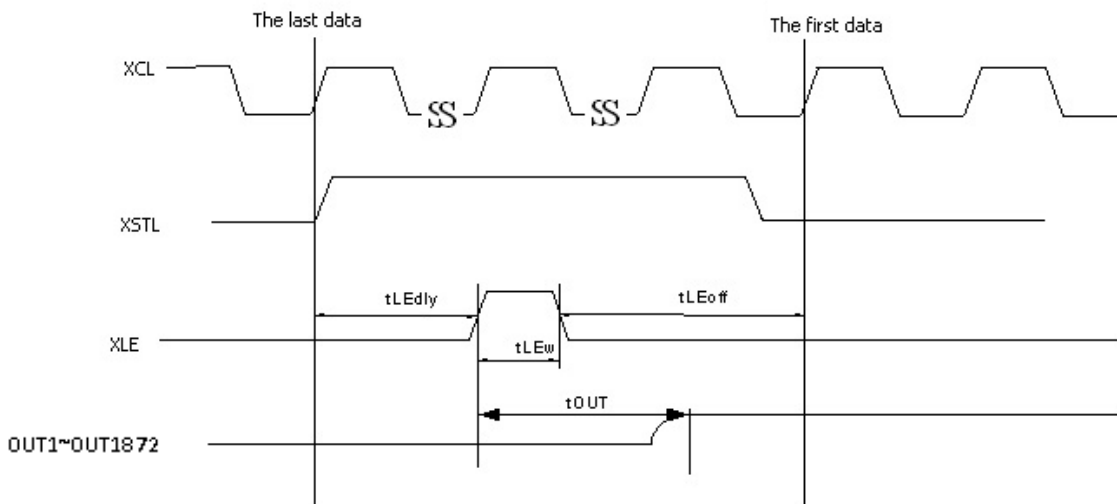

### CLOCK & DATA TIMING

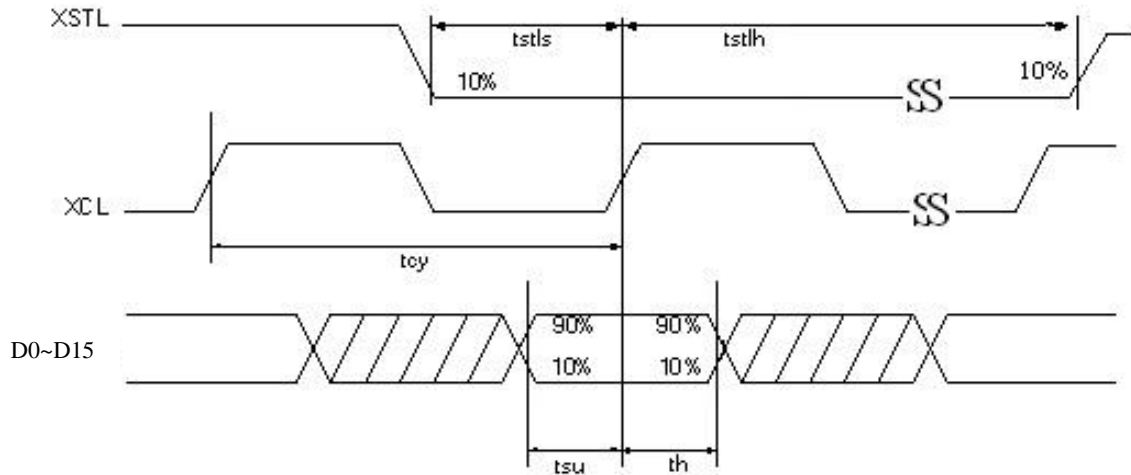

### CKV & SPV TIMING

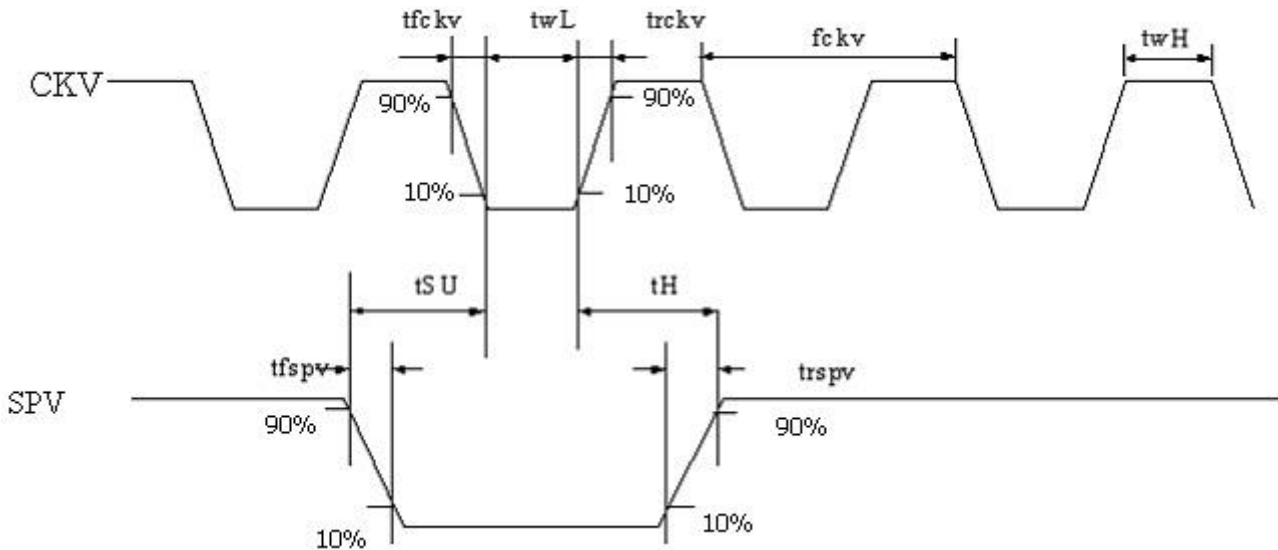

### GATE OUTPUT TIMING

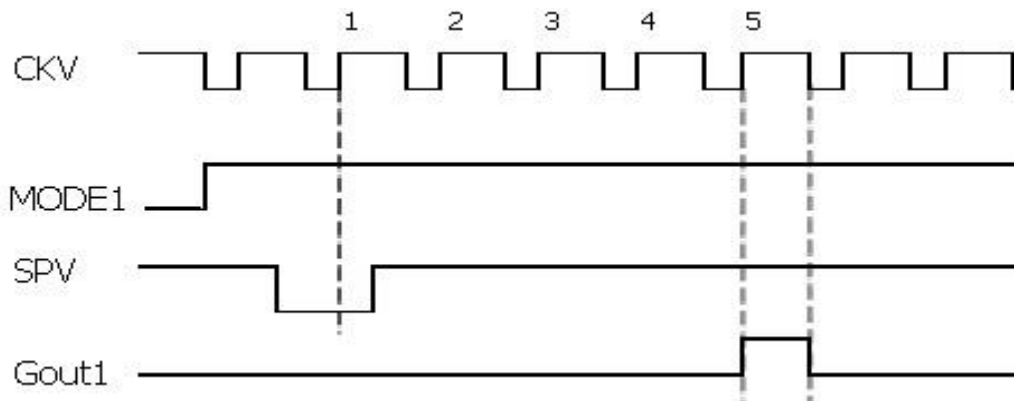

**Note : First gate line on timing**

### 6.4 Refresh Rate

The module is applied at a maximum refresh rate of 85 Hz.

	Min	Max
<b>Refresh Rate</b>	-	85 Hz

### 6.5 Controller Timing

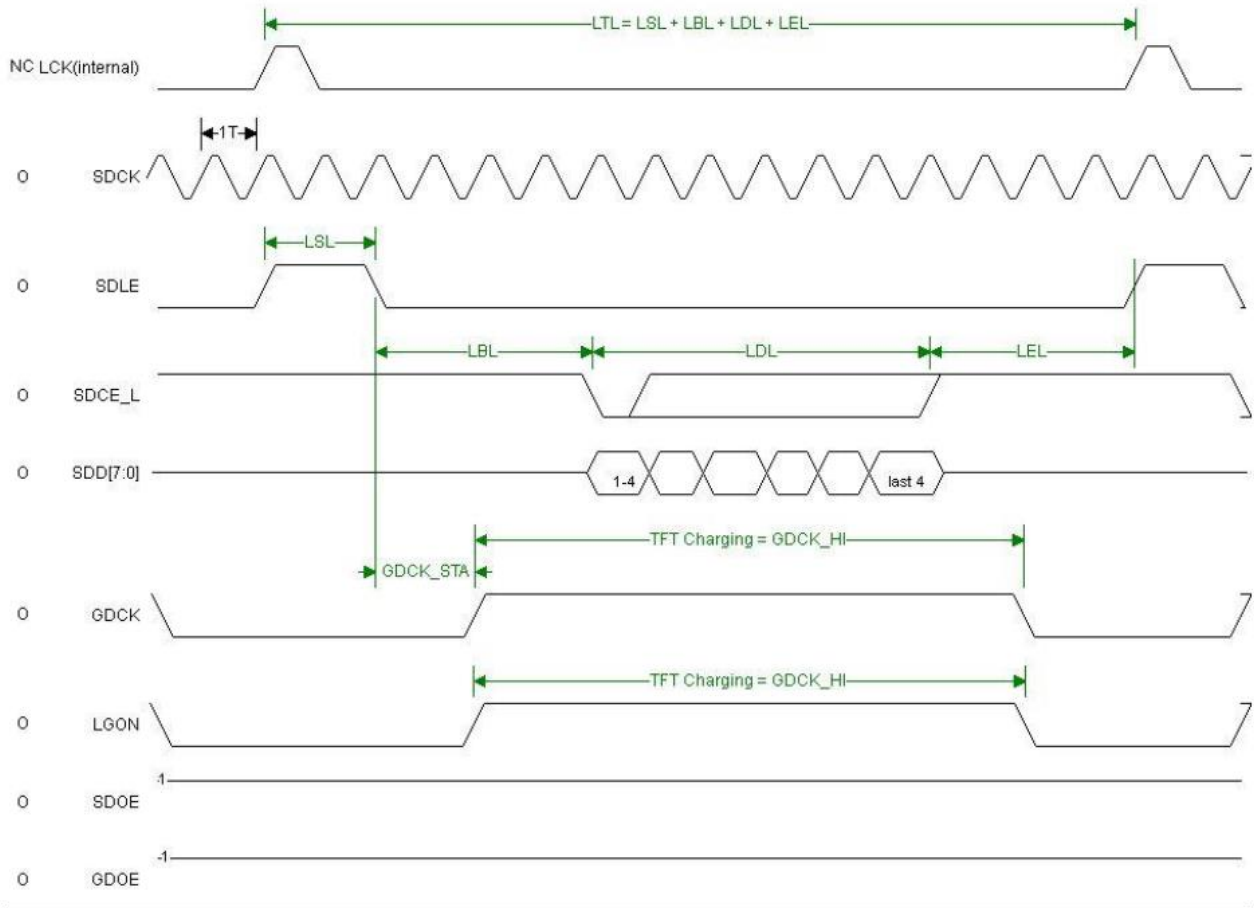

Figure 1 Line Timing in Mode 3

Note: LCK is an internal signal and it is shown for reference only.

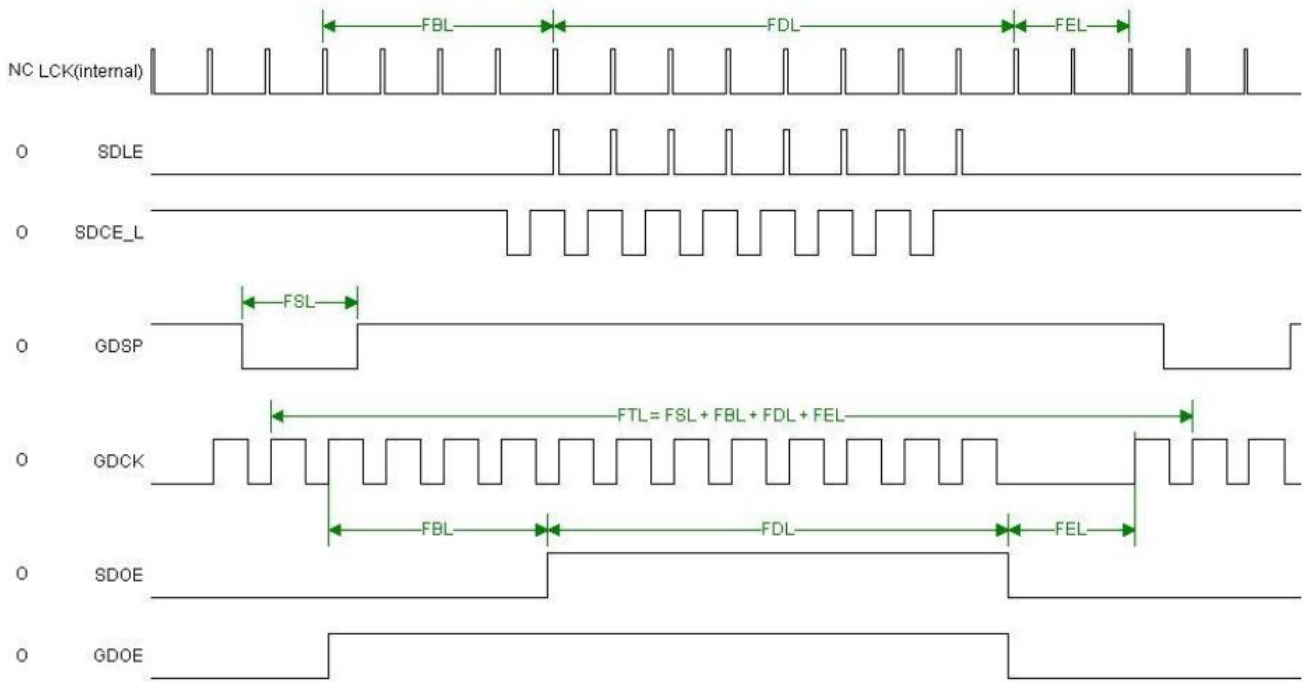

Figure 2 Frame Timing in Mode 3

## 6.6 Timing Parameters Table

Mode	3	Resolution				
SDCK [MHz]	33.33	1872x1404				
Pixels Per SDCK	8					
Line Parameters[SDCK]	LSL	LBL	LDL	LEL	GDCK_STA	LGONL
	18	17	234	7	34	192
Line Parameters[us]	-	-	-	-	-	-
	0.54	0.51	7.02	0.21	1.02	5.76
Frame Parameters [lines]	FSL	FBL	FDL	FEL	-	FR [Hz]
	1	4	1404	12	-	84.99
Frame Parameters [us]	-	-	-	-	-	-
	8.28	33.12	11625.12	99.36	-	-

Note 1: For parameters definition, see Appendix- EPD Panel Timing

Note 2: For Isis Controller GDCK\_STA and LGONL are not settable parameter;  $GDCK\_STA = LBL$ ,  $LGONL = LDL + 0.5$

Note 3: For Freescale SoC GDOE Low pulse represent FSL and GDSP pulses with the first period of FBL

## 7. Power Sequence

Power Rails must be sequenced in the following order :

1. VSS → VDD → VNEG → VPOS (Source driver) → VCOM
2. VSS → VDD → VGL → VGH (Gate driver)

### POWER ON

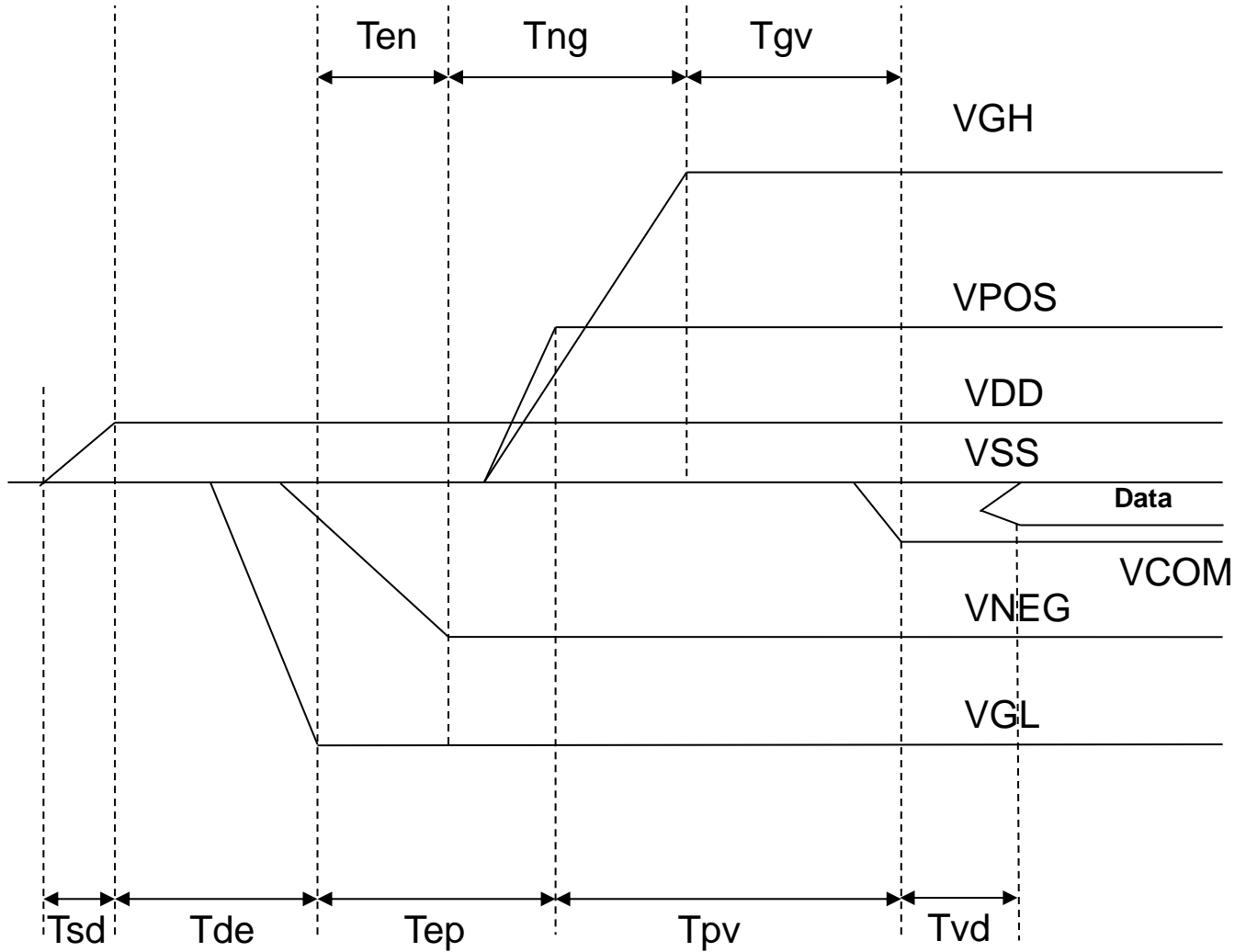

	Min	Max
Tsd	30us	-
Tde	100us	-
Tep	1000us	-
Tpv	100us	-
Tvd	100us	-
Ten	0us	-
Tng	1000us	-
Tgv	100us	-

**POWER OFF**

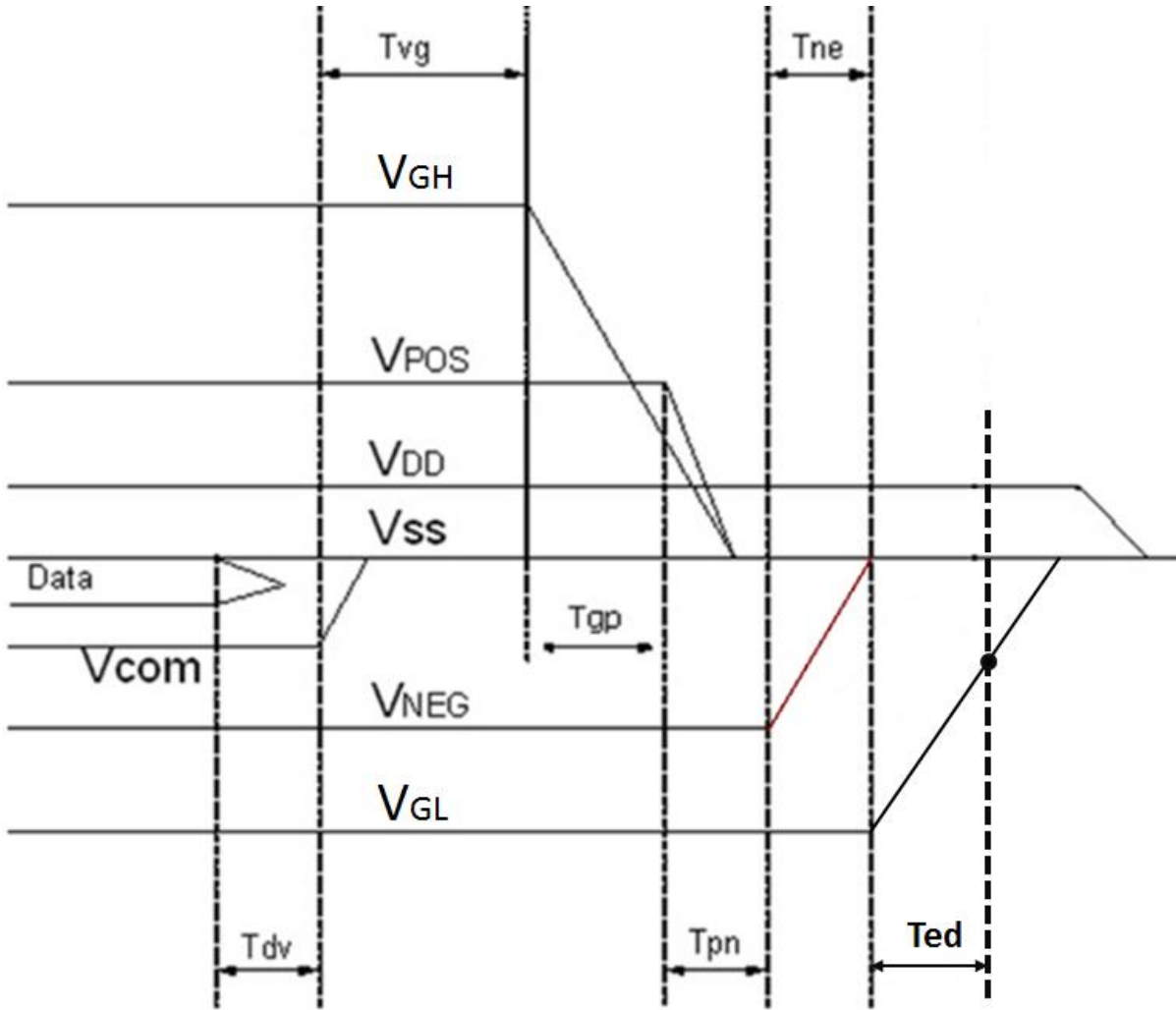

	Min	Max	Remark
Tdv	100μs	-	-
Tvg	0μs	-	-
Tgp	0μs	-	-
Tpn	0μs	-	-
Tne	0μs	-	-
Ted	0.5s	-	Discharged point @ -7.4 Volt

Note 1 : Supply voltages decay through pull-down resistors.

Note 2 : Begin to turn off VGL power after VNEG and VPOS are completely or almost discharged to GND state.

Note 3 : VGL must remain negative of Vcom during decay period

## 8. Optical Characteristics

### 8.1 Specifications

Measurements are made with that the illumination is at an angle of 45 degrees from the perpendicular at the center of sample surface, the detector is perpendicular unless otherwise specified.

T = 25°C

Symbol	Parameter	Conditions	Min	Typ.	Max	Unit	Note
R	Reflectance	White	35	45	-	%	Note 8-1
Gn	N <sub>th</sub> Grey Level	-	-	$DS+(WS-DS) \times n / (m-1)$	-	L*	-
CR	Contrast Ratio	-	10	16	-	-	-

WS: White state , DS: Dark state, Grey state from Dark to White :DS 、 G1 、 G2... 、 Gn... 、 Gm-2 、 WS

m:4 、 8 、 16 when 2 、 3 、 4 bits mode

Note 8-1: Luminance meter: Eye – One Pro Spectrophotometer

### 8.2 Definition of Contrast Ratio

The contrast ratio (CR) is the ratio between the reflectance in a full white area (Rl) and the reflectance in a dark area (Rd):

$$CR = Rl/Rd$$

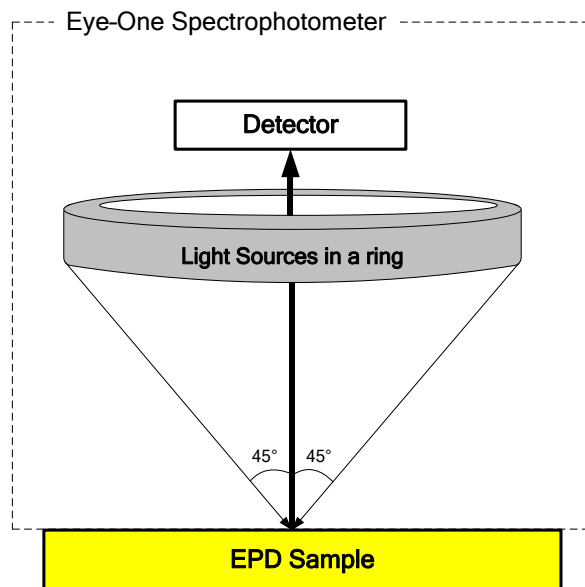



### 8.3 Reflection Ratio

The reflection ratio is expressed as:

$$R = \text{Reflectance Factor}_{\text{white board}} \times (L_{\text{center}} / L_{\text{white board}})$$

$L_{\text{center}}$  is the luminance measured at center in a white area ( $R=G=B=1$ ).  $L_{\text{white board}}$  is the luminance of a standard white board. Both are measured with equivalent illumination source. The viewing angle shall be no more than 2 degrees.

## 9. Handling, Safety and Environmental Requirements and Remark

<b>WARNING</b>
The display glass may break when it is dropped or bumped on a hard surface. Handle with care. Should the display break, do not touch the electrophoretic material. In case of contact with electrophoretic material, wash with water and soap.

<b>CAUTION</b>
The display module should not be exposed to harmful gases, such as acid and alkali gases, which corrode electronic components.
Disassembling the display module can cause permanent damage and invalidate the warranty agreements.
IPA solvent can only be applied on active area and the back of a glass. For the rest part, it is not allowed.

<b>Mounting Precautions</b>
(1) It's recommended that you consider the mounting structure so that uneven force (ex. Twisted stress) is not applied to the module.
(2) It's recommended that you attach a transparent protective plate to the surface in order to protect the EPD. Transparent protective plate should have sufficient strength in order to resist external force.
(3) You should adopt radiation structure to satisfy the temperature specification.
(4) Acetic acid type and chlorine type materials for the cover case are not desirable because the former generates corrosive gas of attacking the PS at high temperature and the latter causes circuit break by electro-chemical reaction.
(5) Do not touch, push or rub the exposed PS with glass, tweezers or anything harder than HB pencil lead. And please do not rub with dust clothes with chemical treatment. Do not touch the surface of PS for bare hand or greasy cloth. (Some cosmetics deteriorate the PS)
(6) When the surface becomes dusty, please wipe gently with absorbent cotton or other soft materials like chamois soaks with petroleum benzene. Normal-hexane is recommended for cleaning the adhesives used to attach the PS. Do not use acetone, toluene and alcohol because they cause chemical damage to the PS.
(7) Wipe off saliva or water drops as soon as possible. Their long time contact with PS causes deformations and color fading.

<b>Data sheet status</b>	
Product specification	This data sheet contains final product specifications.
<b>Limiting values</b>	
Limiting values given are in accordance with the Absolute Maximum Rating System (IEC 134). Stress above one or more of the limiting values may cause permanent damage to the device. These are stress ratings only and operation of the device at these or at any other conditions above those given in the Characteristics sections of the specification is not implied. Exposure to limiting values for extended periods may affect device reliability.	
<b>Application information</b>	
Where application information is given, it is advisory and does not form part of the specification.	
<b>Remark</b>	
All the specifications listed in this document are guaranteed for module only. Post-assembled operation or component(s) may impact module performance or cause unexpected effect or damage and therefore listed specifications is not warranted after any post-assembly operation.	

## Reliability test

	TEST	CONDITION	METHOD	REMARK
1	High-Temperature Operation	T = +50°C, RH = 30% for 240 hrs	IEC 60 068-2-2Be	--
2	Low-Temperature Operation	T = 0°C for 240 hrs	IEC 60 068-2-1Ae	--
3	High-Temperature Storage	T = +70°C, RH = 40% for 240 hrs Test in white pattern	IEC 60 068-2-2Bb	
4	Low-Temperature Storage	T = -25°C for 240 hrs Test in white pattern	IEC 60 068-2-1Ab	--
5	High-Temperature, High-Humidity Operation	T = +40°C, RH = 90% for 168 hrs	IEC 60 068-2-78	--
6	High-Temperature, High-Humidity Storage	T = +60°C, RH = 80% for 240 hrs Test in white pattern	IEC 60 068-2-3CA	
7	Temperature Cycle	-25°C → +70°C, 100 Cycles 30min 30min Test in white pattern	IEC 68-2-14-Nb	--
8	Solar radiation test	765 W/m <sup>2</sup> for 168hrs, 40°C Test in white pattern	IEC60 068-2-5Sa	--
9	Package Vibration	1.04G, Frequency: 10~500Hz Direction: X,Y,Z Duration: 1 hours in each direction	Full packed for shipment	--
10	Package Drop Impact	Drop from height of 122 cm on concrete surface. Drop sequence: 1 corner, 3 edges, 6 faces One drop for each.	Full packed for shipment	--
11	Electrostatic Effect (non-operating)	(Machine model)+/- 250V 0Ω, 200pF	IEC 62179, IEC 62180	--
12	Stylus Tapping	Rubber Pen : Top D=0.8mm Load: 300gf Speed: 30 times/min Total 13500times	--	--

Actual EMC level to be measured on customer application

Note: The protective film must be removed before temperature test.

< Criteria >

In the standard conditions, there is not display function NG issue occurred. (including : line defect ,no image). All the cosmetic specification is judged before the reliability stress.

## 10. Border Definition

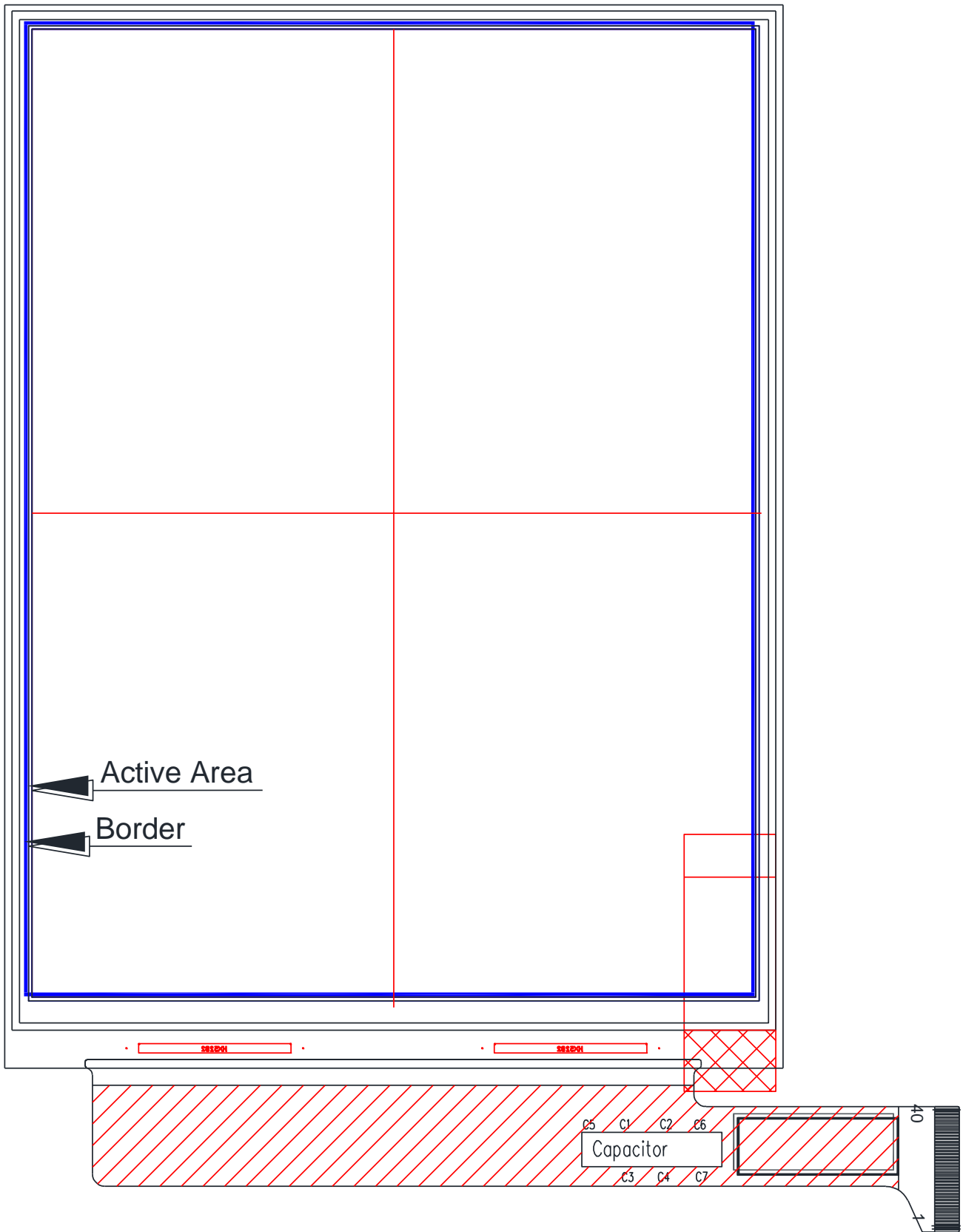

## 11. Block Diagram

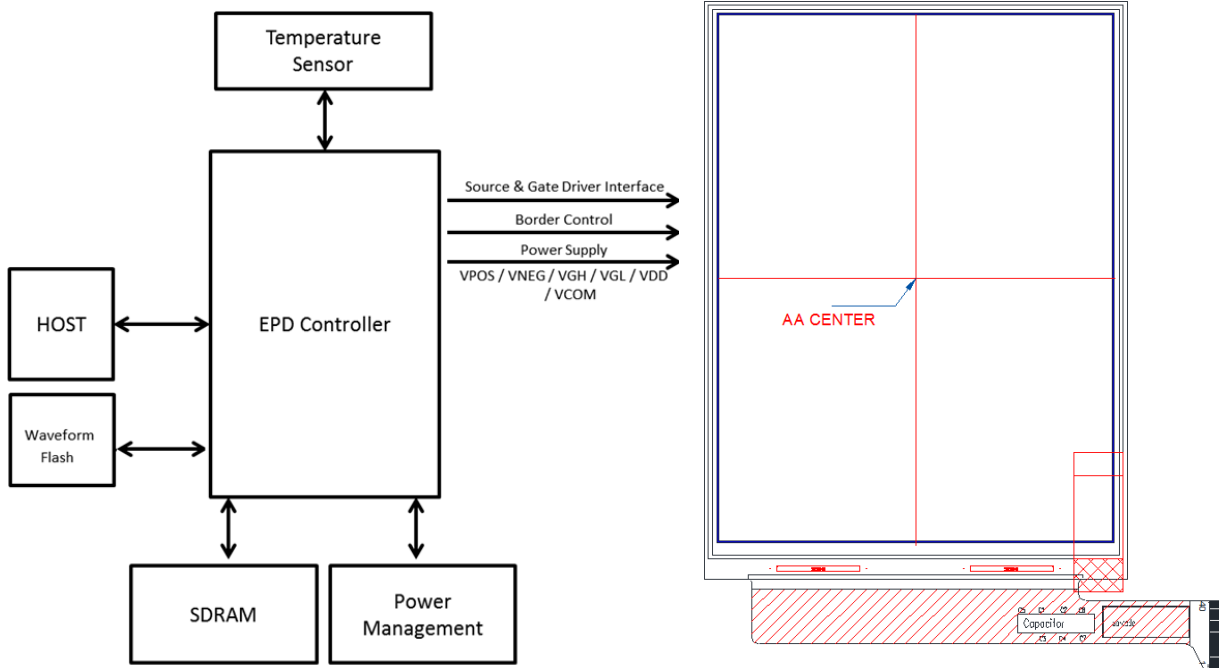

## 12. Packing

REV	DESCRIPTION	DESIGN	DATE
01	Preliminary drawing	CH Dong	20180208

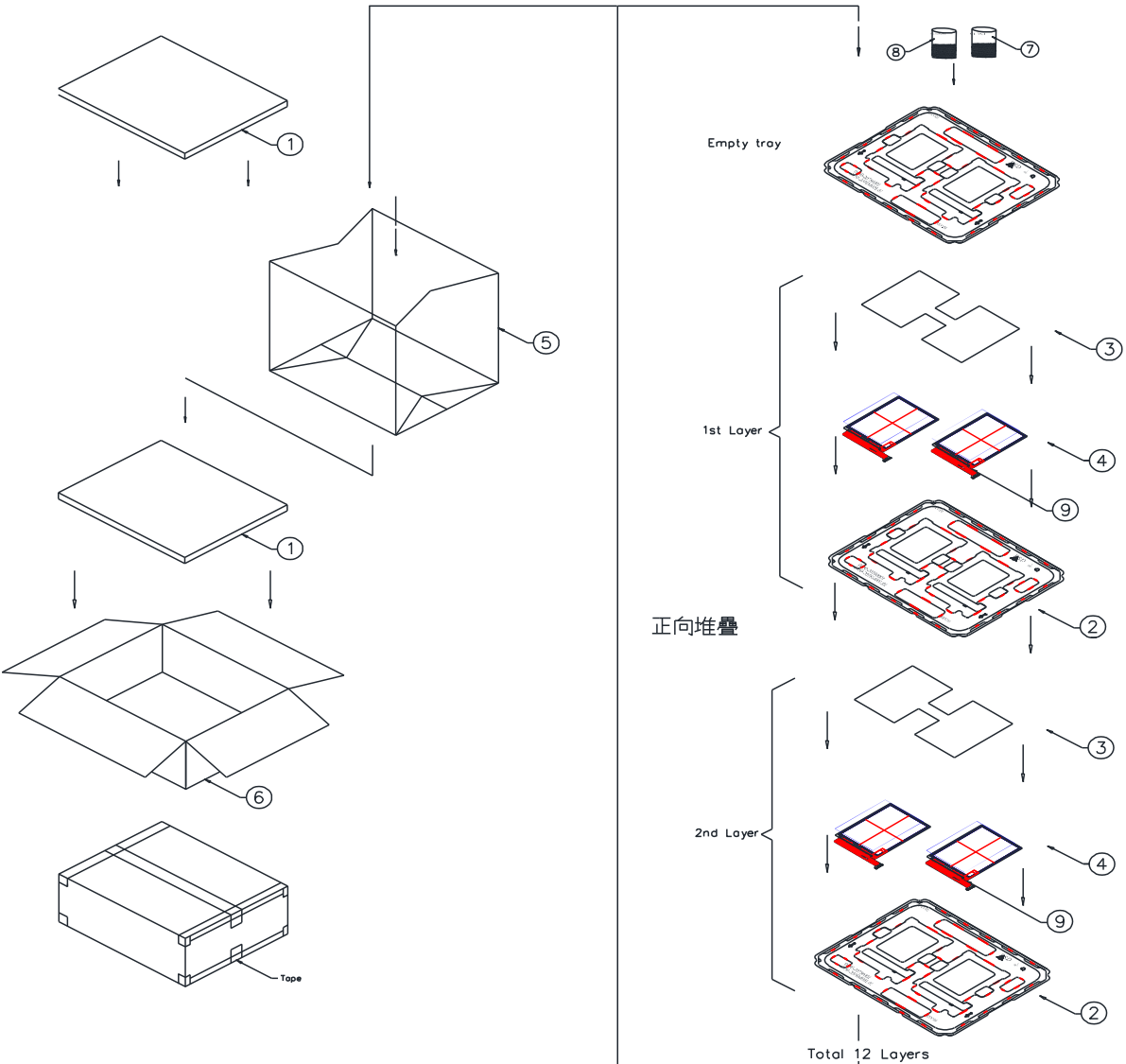

**NOTE:**

- One layer include: 1 piece of cushion sheet, 2 pcs module & 1 piece of tray.
- Q'TY: 24 pcs panel/carton.
- Dimension: 455\*375\*190mm
- Weight: 4.6 KG
- The thickness of raw material of tray before forming is t=1.0mm.

9	easy tape	24	For Remove Protect Sheet
8	30g加厚复合纸(50%纤维)73*95mm(厚料JK0030)	2	
7	防漏袋(保罐容积2.5L)	3	
6	CARTON INTERNAL	1	
5	摺口袋450*380*700mm	1	抗靜電
4	ED078KC2	24	
3	EPE CUSHION SHEET	12	抗靜電
2	PET TRAY	13	抗靜電
1	EPE FOAM	2	
ITEM	PART NO. DESCRIPTION	QTY	RE