

The differential steering gear steering car is a smart car developed based on the Arduino platform, designed from the RC remote control car.

The overall structure is simple and clear; the whole car is mainly black, simple and atmospheric. The front wheel is controlled by the steering gear to provide steering angle; the rear wheel is connected by connecting rod, driven by gear, RS380 high speed and large torque motor is used as the power unit; 64mm is lined with sponge rubber wheel to provide effective grip and prevent the wheel from slipping. The differential car is simple in design and uses rear drive. The RS380 high-speed motor provides sufficient power. The differential case effectively decomposes the two-wheel speed difference, making the car better turn into the corner. When the car is turning, the turning radius of the inner wheel and the outer wheel are different, and the turning radius of the outer wheel is larger than the turning radius of the inner wheel, which requires that the rotational speed of the outer wheel is higher than that of the inner wheel when turning. The role of the differential is to meet the requirements of different wheel speeds on both sides of the car when cornering. In the actual installation, it is often not easy to make mistakes, but the screw specifications are wrong, which will lead to the lack of some screws in the final installation; here, please keep in mind the following screw specifications and usage:

- M2.5 series screws are used to fix plastic parts, ie front and rear wheel bases and differentials;
- M3*6 screws are used to fix the motor bracket;
- M3*8 screws are used to fix the steering gear, steering gear bracket and copper column;

Details to be aware of during the installation of the vehicle:

- The front anti-collision cotton needs to be installed last time, which is convenient for adjusting the front steering structure;
- The front steering cup needs to be flexibly rotated during installation, and the M2.5 * 8 screws cannot be fixed tightly;
- Pay attention to the installation position of the rear wheel seat, mark R to install the left side, and install L to the right side;
- The rear drive shaft installation should be fixed to the differential before the wheel mount is installed;

After the differential is adjusted, the angle must be adjusted to tighten the screw;



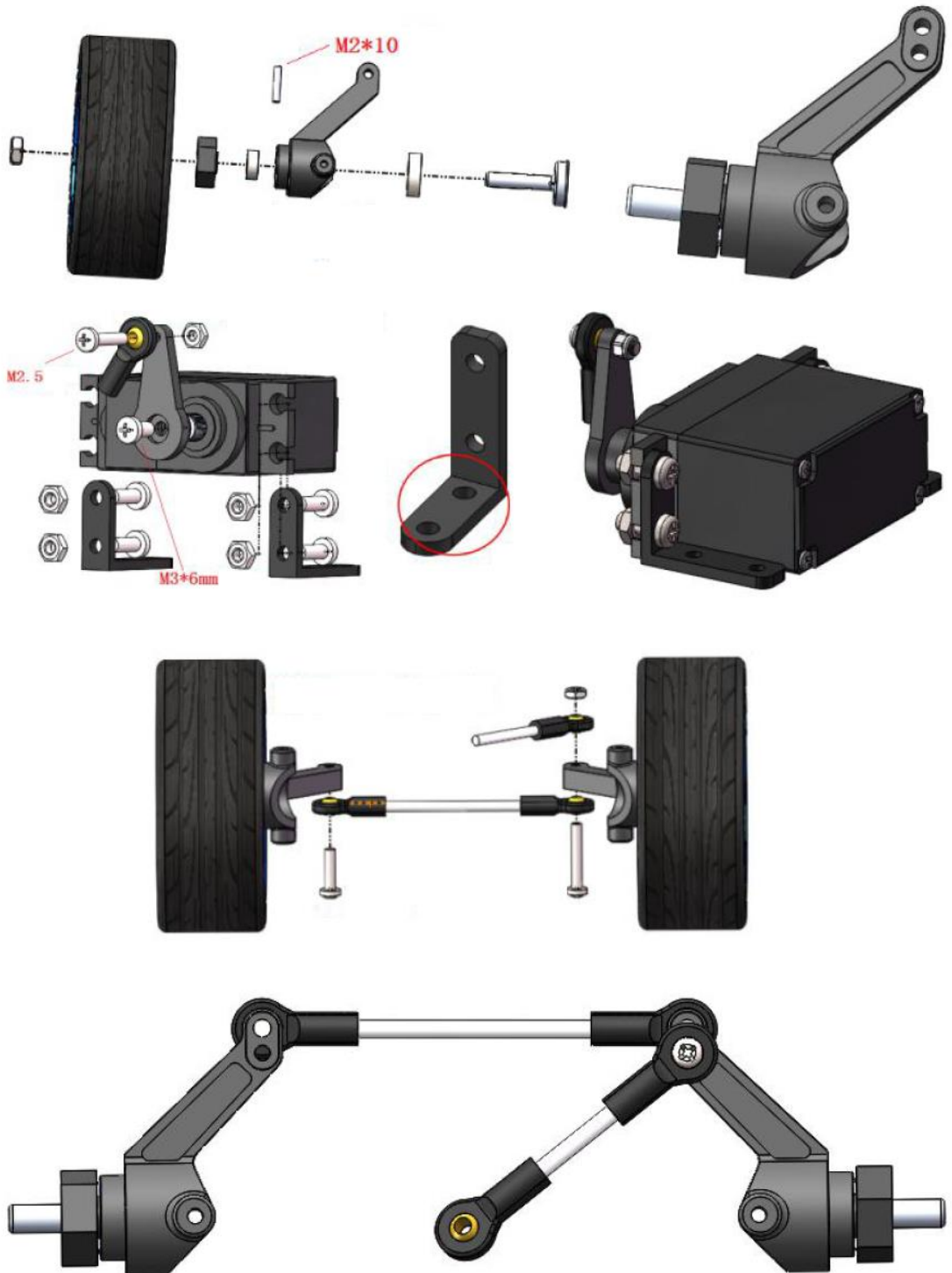

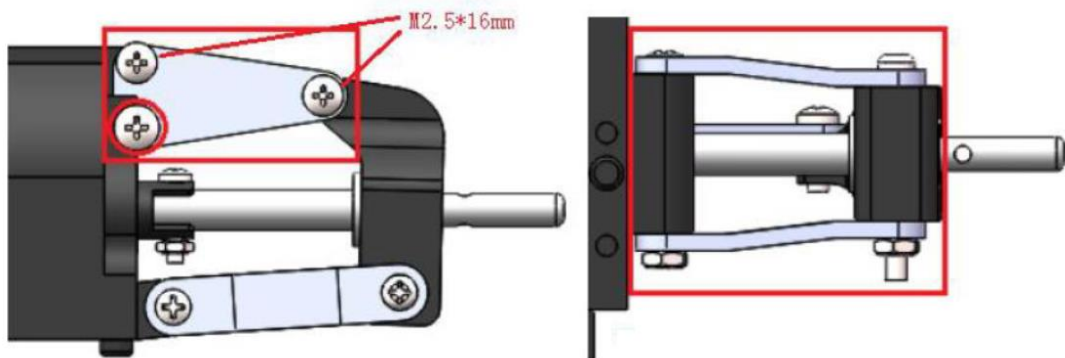
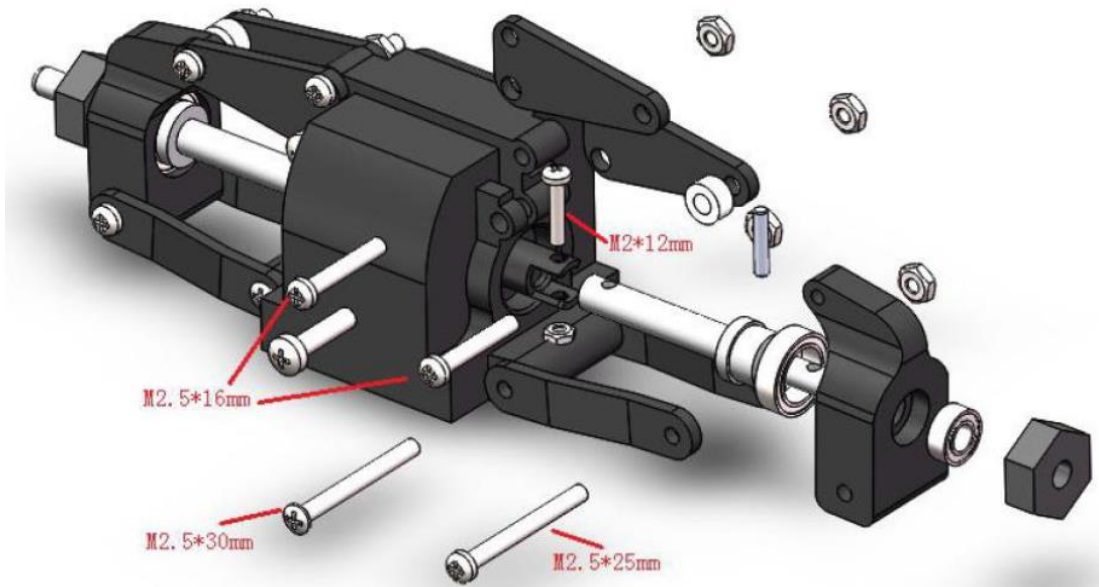
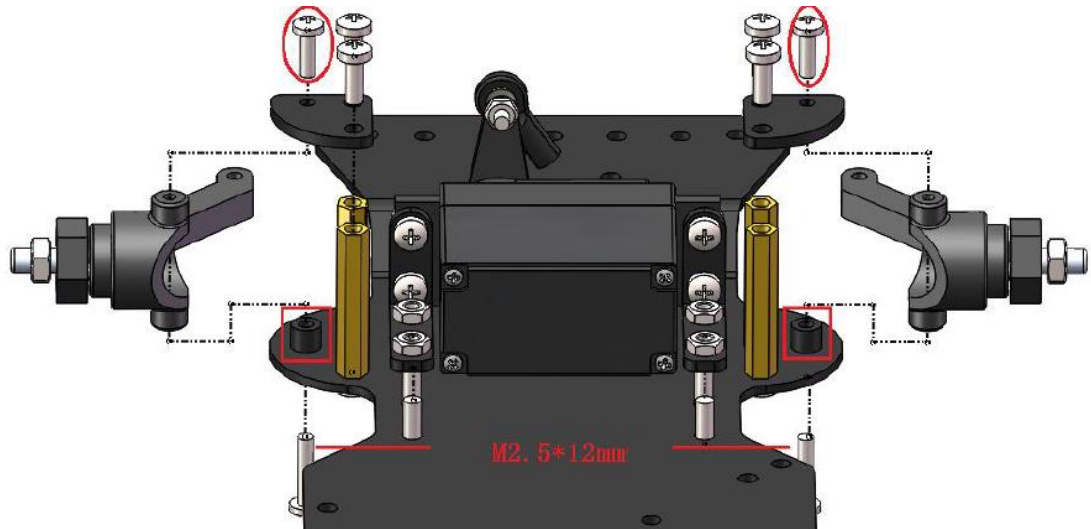

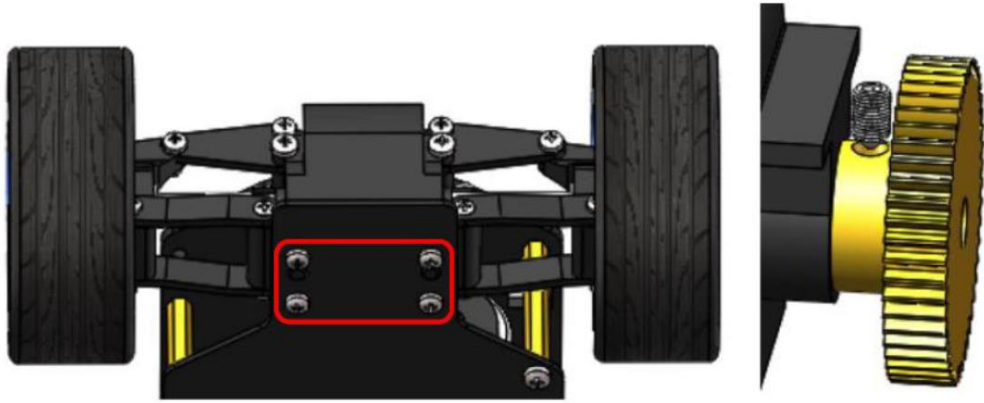

CONNECT MOTOR

