



Connect Tech Inc.
Embedded Computing Experts

www.connecttech.com

USERS GUIDE

Quasar Carrier for NVIDIA® Jetson™ TX2/TX2i/TX1/TX2-4GB Users Guide

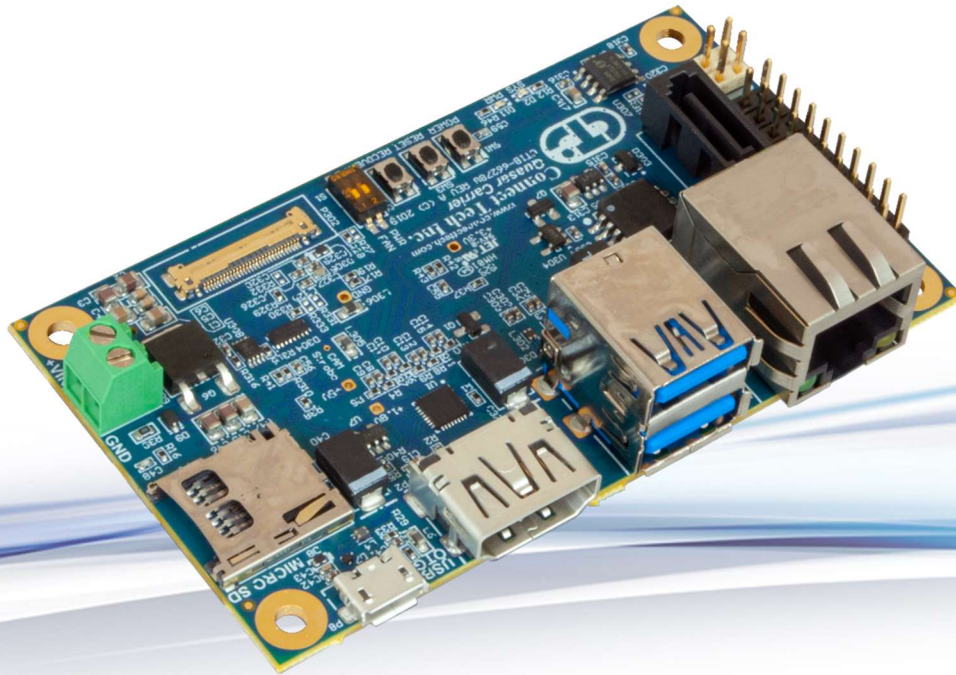

Connect Tech Inc.
42 Arrow Road
Guelph, Ontario
N1K 1S6
www.connecttech.com

Tel: **519-836-1291**
Toll: **800-426-8979** (*North America only*)
Fax: 519-836-4878
Email: sales@connecttech.com
support@connecttech.com

Table of Contents

Table of Contents	2
Preface	4
Disclaimer	4
Customer Support Overview	4
Contact Information	4
Limited Product Warranty.....	5
Copyright Notice.....	5
Trademark Acknowledgment.....	5
ESD Warning	6
Revision History	6
Introduction	6
Product Features and Specifications	7
Product Overview	8
Block Diagram	8
Connector Locations (Top Side)	9
Connector Locations (Bottom Side).....	10
Connector Summary.....	11
Switch Summary & Locations	11
Detailed Feature Description	12
Jetson™ TX2/TX2i/TX1 Board-to-Board Connector	12
System Expansion IO Connector.....	13
System Expansion IO Connector – Detailed Signal Descriptions	14
HDMI Connector.....	15
10/100/1000 Ethernet (GBE).....	16
USB 3.0.....	17
USB OTG.....	18
USB OTG – Host Mode	18
USB OTG – Client Mode (Used for Image Flashing).....	18
Input Power	19
Input Power - Wiring.....	19
MIPI 1x4 CSI	20
SATA	20
CAN	21
Switch Details	21
DIP Switch Details (S1)	21
S1 Usage Examples	22
Push Button Details (SW1, SW2, SW3).....	23
Typical Installation	24
Power Supply	25
On-Board Indicator LED's	26
Current Consumption Details	27
Software / BSP Details	28
Connect Tech's Custom L4T BSP (CTI-L4T)	28



NVIDIA Jetpack for L4T	28
Force Recovery Mode	29
Thermal Details	30
Mechanical Details	31
3D STEP Model	31
2D Dimensions Drawing	31
Stack-up Drawing.....	32
Cables.....	33
Related Part Numbers.....	33

Preface

Disclaimer

The information contained within this user's guide, including but not limited to any product specification, is subject to change without notice.

Connect Tech assumes no liability for any damages incurred directly or indirectly from any technical or typographical errors or omissions contained herein or for discrepancies between the product and the user's guide.

Customer Support Overview

If you experience difficulties after reading the manual and/or using the product, contact the Connect Tech reseller from which you purchased the product. In most cases the reseller can help you with product installation and difficulties.

In the event that the reseller is unable to resolve your problem, our highly-qualified support staff can assist you. Our support section is available 24 hours a day, 7 days a week on our website at: <http://connecttech.com/support/>. See the contact information section below for more information on how to contact us directly. Our technical support is always free.

Contact Information

Mail/Courier

Connect Tech Inc.
Technical Support
42 Arrow Road
Guelph, Ontario
Canada N1K 1S6

Email/Internet

sales@connecttech.com
support@connecttech.com
www.connecttech.com

Note:

Please go to the [Connect Tech Resource Center](#) for product manuals, installation guides, device drivers, BSPs and technical tips. Submit your [technical support](#) questions to our support engineers.

Telephone/Facsimile

Technical Support representatives are ready to answer your call Monday through Friday, from 8:30 a.m. to 5:00 p.m. Eastern Standard Time. Our numbers for calls are:

Toll Free: 800-426-8979 (North America only)

Telephone: 519-836-1291 (Live assistance available 8:30 a.m. to 5:00 p.m. EST, Monday to Friday)

Facsimile: 519-836-4878 (on-line 24 hours)



Limited Product Warranty

Connect Tech Inc. provides a one-year Warranty for the Quasar Carrier. Should this product, in Connect Tech Inc.'s opinion, fail to be in good working order during the warranty period, Connect Tech Inc. will, at its option, repair or replace this product at no charge, provided that the product has not been subjected to abuse, misuse, accident, disaster or non-Connect Tech Inc. authorized modification or repair.

You may obtain warranty service by delivering this product to an authorized Connect Tech Inc. business partner or to Connect Tech Inc. along with proof of purchase. Product returned to Connect Tech Inc. must be pre-authorized by Connect Tech Inc. with an RMA (Return Material Authorization) number marked on the outside of the package and sent prepaid, insured and packaged for safe shipment. Connect Tech Inc. will return this product by prepaid ground shipment service.

The Connect Tech Inc. Limited Warranty is only valid over the serviceable life of the product. This is defined as the period during which all components are available. Should the product prove to be irreparable, Connect Tech Inc. reserves the right to substitute an equivalent product if available or to retract the Warranty if no replacement is available.

The above warranty is the only warranty authorized by Connect Tech Inc. Under no circumstances will Connect Tech Inc. be liable in any way for any damages, including any lost profits, lost savings or other incidental or consequential damages arising out of the use of, or inability to use, such product.

Copyright Notice

The information contained in this document is subject to change without notice. Connect Tech Inc. shall not be liable for errors contained herein or for incidental consequential damages in connection with the furnishing, performance, or use of this material. This document contains proprietary information that is protected by copyright. All rights are reserved. No part of this document may be photocopied, reproduced, or translated to another language without the prior written consent of Connect Tech, Inc.

Copyright © 2019 by Connect Tech, Inc.

Trademark Acknowledgment

Connect Tech, Inc. acknowledges all trademarks, registered trademarks and/or copyrights referred to in this document as the property of their respective owners. Not listing all possible trademarks or copyright acknowledgments does not constitute a lack of acknowledgment to the rightful owners of the trademarks and copyrights mentioned in this document.

ESD Warning



Electronic components and circuits are sensitive to ElectroStatic Discharge (ESD). When handling any circuit board assemblies including Connect Tech carrier assemblies, it is recommended that ESD safety precautions be observed. ESD safe best practices include, but are not limited to:

- Leaving circuit boards in their antistatic packaging until they are ready to be installed.
- Using a grounded wrist strap when handling circuit boards, at a minimum you should touch a grounded metal object to dissipate any static charge that may be present on you.
- Only handling circuit boards in ESD safe areas, which may include ESD floor and table mats, wrist strap stations and ESD safe lab coats.
- Avoiding handling circuit boards in carpeted areas.
- Try to handle the board by the edges, avoiding contact with components.

Revision History

Revision	Date	Changes
0.00	2019/09/24	Preliminary Release

Introduction

Connect Tech’s Quasar Carrier for NVIDIA® Jetson™ TX2/TX2i/TX1/TX2-4GB brings a low cost deployable Jetson™ TX2/TX2i/TX1/TX2-4GB Solution to the market. Designed to match the NVIDIA® Jetson™ TX2, TX2i, TX1 or TX2-4GB module form factor, the Quasar’s design includes Gigabit Ethernet, HDMI Video, 2 x USB 3.0, USB 2.0 (w/ OTG functionality), MIPI CSI-2, SATA, 2 x UART ports, SD card, isolated CAN and 4-bits of GPIO.

Product Features and Specifications

Feature	Quasar Carrier for NVIDIA Jetson TX2/TX2i/TX1/TX2-4GB
Module Compatibility	NVIDIA Jetson TX2, TX2-4GB, TX2i or TX1 - Datasheet Downloads: Module Datasheet - SoC Datasheet
Mechanical Dimensions	X/Y Footprint: 87mm x 50mm - Tallest Component Height: 13.42mm (<i>From Top PCB Surface of Quasar</i>) - Total Stack Height: 30.18mm (<i>Quasar + TX2/TX2i/TX1/TX2-4GB Module + TX2/TX1 Flat Heatplate</i>) 3D STEP Model: Download Here
Video Output	1x HDMI 2.0 (Supports up to HDMI 2.0 UHD 4K [2160p] at 60Hz)
Ethernet	1x Gigabit Ethernet - 10/100/1000 BASE-T
USB	2x USB 3.0 (5Gbps, 1.4 A Maximum Current Sourcing) Dual Stack Connector 1x USB 2.0 (w/ OTG functionality)
Audio Output	HDMI Integrated
UART	2x 3.3V UART Ports - TX/RX lines only
GPIO	4-bits GPIO - 3.3V CMOS Level - Configurable as inputs or outputs
SD Card	1x microSD Card Slot - 4-bit Data - Support for SD 4.0 Specification without UHS-II
Video Inputs	Video Inputs can be accessed through any of the of the following interfaces: - USB 3.0 / 2.0 - Gigabit Ethernet - 1x 4-lane MIPI
I2C	1x I2C (Master Controller) - Pullup Level: 1k ohm - Operation Speeds: 100kbit/s, 400kbit/s, 1Mbit/s, 3.4Mbit/s
CAN	1x CAN 2.0b (isolated, using CAN transceiver)
MIPI	1x 4-lane MIPI CSI-2 (I-PEX Connector)
SATA	1x SATA (7-pin Data Connector)
Misc Interfaces	User Power Output Pins: +3.3V and +5V Fan Connection: 4-pin, +5V, PWM Capability On-board and External Button Interfaces: Reset, Power, Recovery External RTC Battery Connection
Power Requirements	Input Voltage Range: +9V to +14V DC TX2i Module Consumption: 20W; TX2/TX1 Module Consumption: 6.5W to 15W (<i>dependent on CPU/GPU utilization</i>) Quasar Carrier Consumption (no module or peripherals connected): 1.1W <i>Peripheral current consumption listed on Pg. 27</i>
Temperature	TX2/TX1 Module Operating Temperature Range: -25°C to +80°C TX2/TX1 SoC Junction Temperature Range: -25°C to +105°C TX2i Module & Quasar Carrier Operating Temperature Range: -40°C to +85°C
Weight	45 g
Warranty and Support	1 Year Warranty and Free Support

Product Overview

Block Diagram

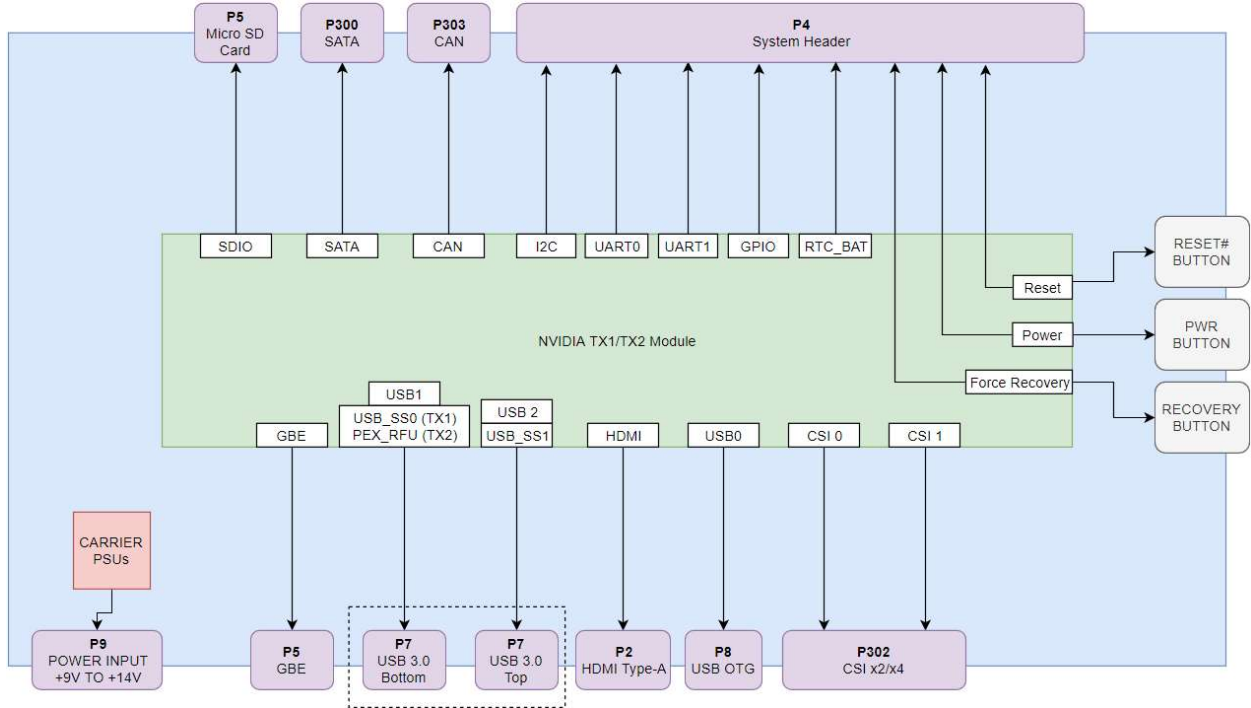

Connector Locations (Top Side)

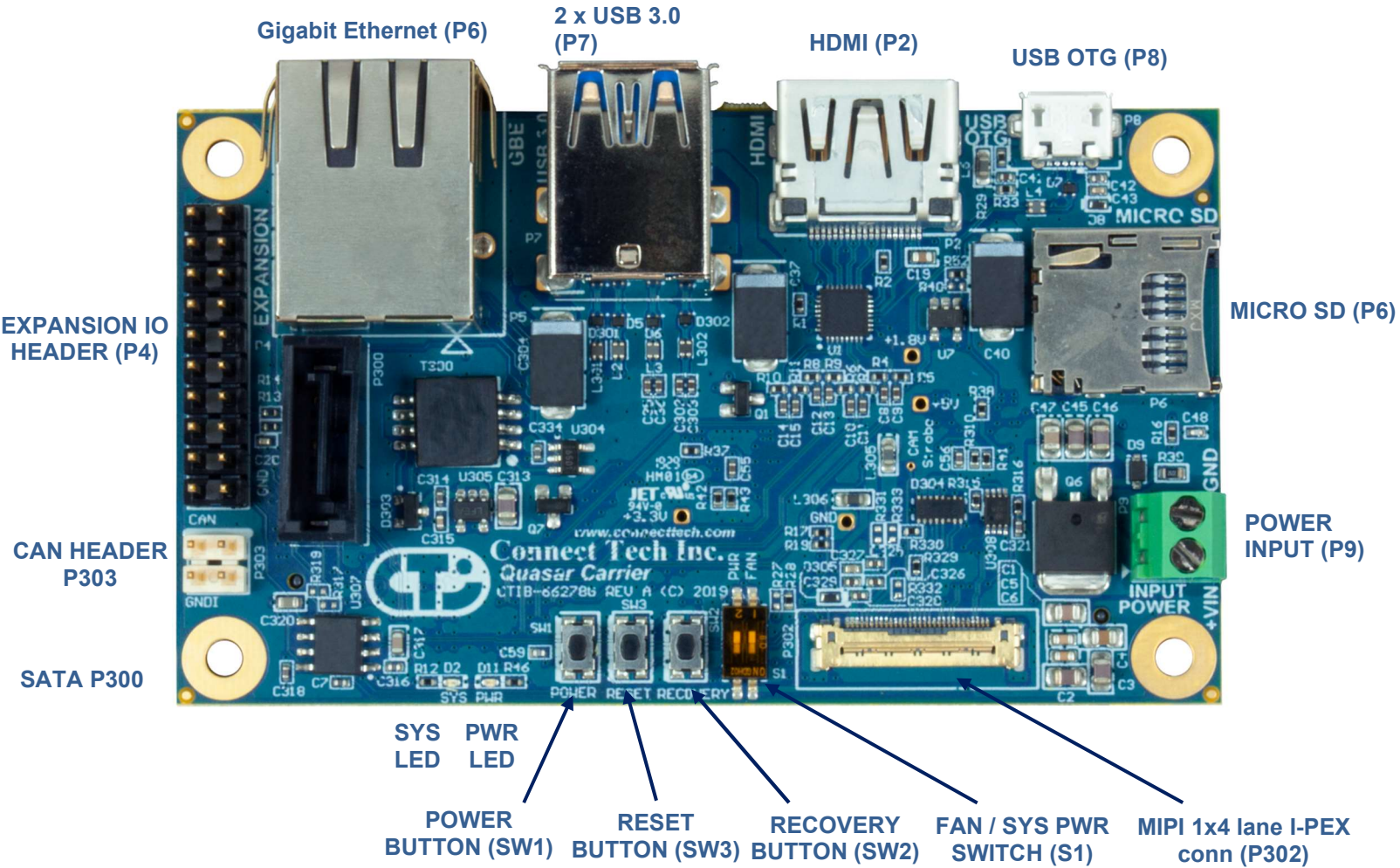



Connector Locations (Bottom Side)

FAN HEADER
P3

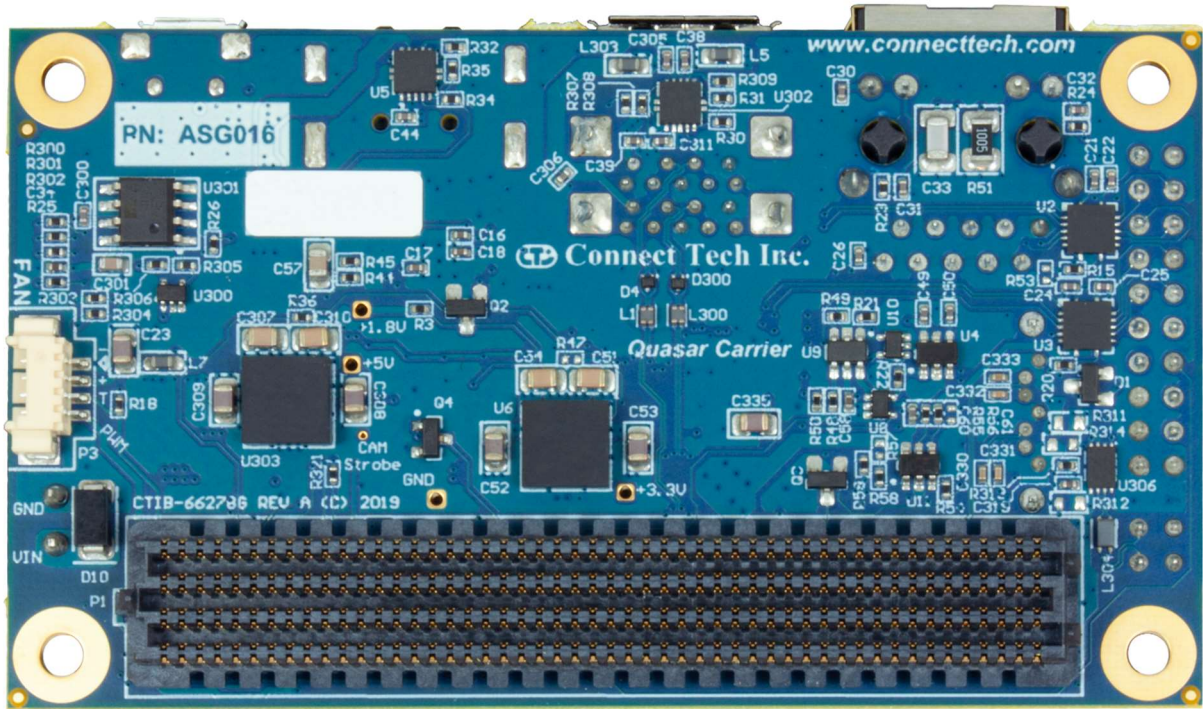

CONNECTOR FOR TX1/TX2/TX2i/TX2-4GB MODULE
P1

Connector Summary

Designator	Connector	Description
P1	TX2/TX2i/TX1/TX2-4GB Module Connector	NVIDIA Jetson TX2/TX2i/TX1/TX2-4GB Module Board-to-Board Connector
P2	HDMI	HDMI 2.0 Maximum: 6Gbps, 24bpp, 4096x2160@60Hz
P4	Expansion IO Header	Expansion IO Header Interfacing to all Misc IO
P5	Gigabit Ethernet	Gigabit Ethernet 10/100/1000 BASE-T Connection
P6	Micro SD Card Slot	Micro SD Card Slot (4-bit Data, Support for SD 4.0)
P7	2 x USB 3.0	2 x USB 3.0 Type-A Host Connection
P8	USB OTG	USB OTG (Host Mode and Client Mode capable)
P9	Power Input	DC Power Input (+9V to +14V)
P300	SATA	SATA (7-pin Data Connector)
P302	MIPI 1x4 CSI I-PEX	MIPI Camera Expansion connector
P303	CAN	CAN Bus Connector

Switch Summary & Locations

Designator	Function	Description
S1	Fan / Power Control	Power Start-up Control, FAN PWM / Always ON Control
SW1	Power Button	Power Button, Press to Power ON or OFF
SW2	Reset Button	Reset Button, Press to initiate Reset Sequence
SW3	Recovery	Use to initiate a recovery mode, and flash new image via USB OTG

Detailed Feature Description

Jetson™ TX2/TX2i/TX1/TX2-4GB Board-to-Board Connector

With the NVIDIA Jetson™ TX2, TX2i, TX2-4GB or TX1, the processor and chipset are implemented on the Jetson™ TX2/TX2i/TX1/TX2-4GB Module. This connects to the Quasar Carrier via a Samtec SEARAY™ Board to Board Connector.

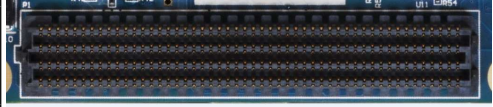
Function	NVIDIA Jetson™ TX2/TX2i/TX1/TX2-4GB Interface	
Location	P1	
Type	Samtec SEARAY™ Connector	
Carrier Connector	Part Number: SEAM-50-03.0-S-08-2-A-K-TR (8.0mm stacking height) Manufacturer: Samtec	
Mating Connector	Part Number: SEAF-50-05-S-08-02-A-K (installed on Jetson™ TX2/TX2i/TX1/TX2-4GB) Manufacturer: Samtec	
Pinout	Refer to NVIDIA's Jetson™ TX2/TX2i/TX1/TX2-4GB System-on-Module datasheet for pinout details	
Board-to-Board Standoff Height	8.0mm height M3 Standoffs Required between NVIDIA Jetson TX2/TX1 Module and Quasar (ASG016) Carrier 5.0mm height M3 Standoffs Required between NVIDIA Jetson TX2i/TX2-4GB Module and Quasar (ASG016) Carrier	

System Expansion IO Connector

The System Expansion header has numerous interfaces to connect external peripherals and IO. As well as the ability to provide external connection to the Recovery, Reset and Power Buttons. The System Expansion IO Connector also has 2 voltage output pins to allow powering of external devices.

Function	System Connector			
Location	P4			
Type	0.1" / 2.54mm Pitch IDC Header (DIL)			
Carrier Connector	Part Number: TSW-110-07-L-D Manufacturer: Samtec			
Mating Connector	Any IDC / DIC 0.1" Cable, Socket or Jumper Wire Assemblies			
Pinout	Pin	Description	Pin	Description
	1	+3.3V OUTPUT	2	+5V OUTPUT
	3	UART0 TX	4	UART0 RX
	5	UART1 TX	6	UART1 RX
	7	GPIO-0	8	GPIO-1
	9	GPIO-2	10	GPIO-3
	11	I2C CLK	12	I2C SDA
	13	RECOVERY	14	RTC BAT INPUT
	15	RESET	16	GND
	17	POWER BUTTON	18	GND
	19	GND	20	GND



System Expansion IO Connector – Detailed Signal Descriptions

Signal Name	Description	Type	Pin Number(s)
+3.3V OUTPUT	+3.3V Power Output Pin <ul style="list-style-type: none"> - Max output should be limited to 1A - Please note there is no external fuse. 	Output	1
+5V OUTPUT	+5V Power Output Pin <ul style="list-style-type: none"> - Max output should be limited to 1A - Please note there is no external fuse. 	Output	2
UART0 TX	UART 0 Transmit Pin <ul style="list-style-type: none"> - This signal is the UART port 0 output from the TX2/TX2i/TX1/TX2-4GB Module - This is level shifted on the Quasar carrier to support 3.3V logic. - Under L4T this port will show up as /dev/ttyS0 	Output 3.3V CMOS	3
UART0 RX	UART 0 Receive Pin <ul style="list-style-type: none"> - This signal is the UART channel 0 input on TX2/TX2i/TX1/TX2-4GB Module - This is level shifted on the Quasar carrier to support 3.3V logic. - Under L4T this port will show up as /dev/ttyS0 	Input 3.3V CMOS	4
UART1 TX	UART 1 Transmit Pin <ul style="list-style-type: none"> - This signal is the UART channel 1 output from the TX2/TX2i/TX1/TX2-4GB Module - This is level shifted on the Quasar carrier to support 3.3V logic. - Under L4T this port will show up as /dev/ttyTHS2 	Output 3.3V CMOS	5
UART1 RX	UART 1 Receive Pin <ul style="list-style-type: none"> - This signal is the UART channel 1 input on TX2/TX2i/TX1/TX2-4GB Module - This is level shifted on the Quasar carrier to support 3.3V logic. - Under L4T this port will show up as /dev/ttyTHS2 	Input 3.3V CMOS	6
GPIO-[0:3]	GPIO Bits 0 to 3 <ul style="list-style-type: none"> - This signal is the GPIO Bit 0 and can be configured as an Input or an Output - This is level shifted on the Quasar carrier to support 3.3V logic. Please reference our GPIO KDB for TX2/TX2i/TX1/TX2-4GB values.	Input/Output Configurable 3.3V CMOS	7,8,9,10
I2C CLK	I2C Clock Signal <ul style="list-style-type: none"> - This is clock signal on the I2C bus - This signal has a pull up on the TX2/TX2i/TX1/TX2-4GB module to +3.3V Under L4T, please reference our I2C KDB for TX2/TX2i/TX1/TX2-4GB for bus number.	Output +3.3V Open Drain	11
I2C SDA	I2C Data Signal <ul style="list-style-type: none"> - This is data signal on the I2C bus - This signal has a pull up on the TX2/TX2i/TX1/TX2-4GB module to +3.3V Under L4T, please reference our I2C KDB for TX2/TX2i/TX1/TX2-4GB for bus number.	Bidirectional +3.3V Open Drain	12

RECOVERY	System Recovery Pin <ul style="list-style-type: none"> - Shorting this signal to Ground will initialize a system recovery procedure 	Input	13
RTC BAT INPUT	RTC Battery Input <ul style="list-style-type: none"> - Use this pin to connect a backup battery source (Coin Cell or other) to sustain the RTC clock on the TX2/TX2i/TX1/TX2-4GB module. - The voltage should be provided from a 3V source 	Input	14
RESET	External Reset Button Source <ul style="list-style-type: none"> - Pulse / Short this signal to GND to initiate a reset sequence 	Input	15
POWER BUTTON	External Power Button Source <ul style="list-style-type: none"> - Pulse / Short this signal to GND to initiate a power sequence 	Input	17
GND	Ground / Reference Connection <ul style="list-style-type: none"> - This pin is connected to the Quasar Carrier's main digital ground connection - Use this pin as a reference/return for any externally connected peripherals to the Expansion IO Connector 	Reference	16,18,19,20

HDMI Connector

Function	HDMI Connector			
Location	P2			
Type	HDMI Type-A Connector (Female)			
Carrier Connector	Part Number: A35071TR-ND Manufacturer: TE Connectivity			
Mating Connector	Any HDMI Type-A Cable Assembly			
Pinout	Pin	Description	Pin	Description
	1	TMDS Data2+	2	TMDS Data2 GND
	3	TMDS Data2-	4	TMDS Data1+
	5	TMDS Data1 GND	6	TMDS Data1-
	7	TMDS Data0+	8	TMDS Data0 GND
	9	TMDS Data0-	10	TMDS Clock+
	11	TMDS Clock GND	12	TMDS Clock-
	13	CEC	14	No Connect
	15	DDC clock	16	DDC data
	17	DDC GND	18	+5V Power
19	Hot Plug Detect			

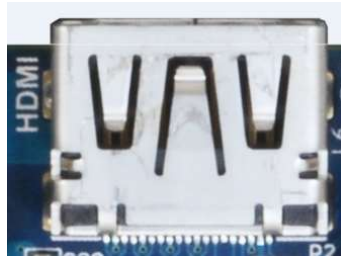
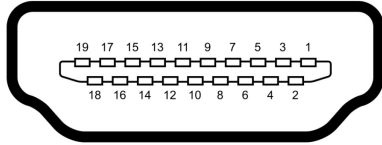
NVIDIA Jetson TX2/TX2i/TX1/TX2-4GB Fan

Function	NVIDIA Jetson TX2/TX2i/TX1/TX2-4GB Fan Control	
Location	P4	
Type	Molex PicoBlade Header	
Carrier Connector	Part Number: 53261-0471 Manufacturer: Molex	
Mating Connector	Part Number: 51021-0400 Manufacturer: Molex	
Pinout	Pin	Description
	1	GND
	2	+5V
	3	TACH
	4	PWM



NOTE: Please note that Fan PWM (speed control) is NOT natively supported by the stock L4T builds.

If users wish to use the native builds you must enable the S1 DIP Switch to put the Fan into the Always ON mode.

To enable PWM functionality (speed control) users must deploy CTI-L4T BSP and enable the S1 DIP Switch to put the Fan into the PWM Enabled mode.

10/100/1000 Ethernet (GBE)

Function	Gigabit Ethernet Connector			
Location	P5			
Type	RJ-45 8p8c			
Carrier Connector	Part Number: JXD0-0001NL Manufacturer: Pulse Electronics Network			
Mating Connector	Any RJ-45 Plug with Cat5, Cat5e, Cat6 Type Cabling			
Pinout	Pin	Description	Pin	Description
	J1	TD0+	J2	TD0-
	J3	TD1+	J4	TD2+
	J5	TD2-	J6	TD1-
	J7	TD3+	J8	TD3-

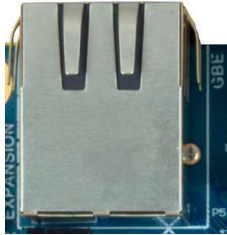
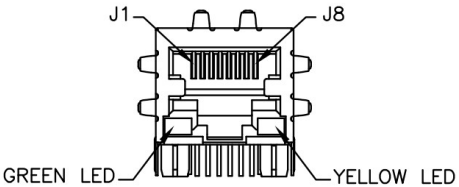
microSD Card Slot

Function	microSD Card Slot			
Location	P7			
Type	Molex microSD Memory Card Connector			
Carrier Connector	502570-0893			
Pinout	Pin	Description	Pin	Description
	1	SDIO DATA2	2	SDIO DATA3
	3	SDIO CMD	4	SDIO VCC
	5	SDIO CLK	6	GND
	7	SDIO DATA0	8	SDIO DATA1
	9	GND	10	SDIO CD

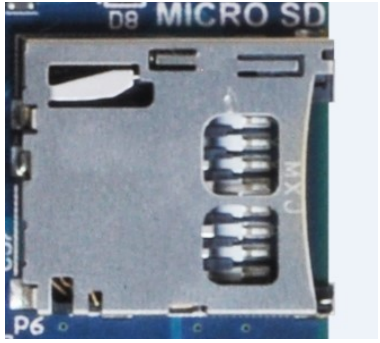

USB 3.0

Function	USB 3.0			
Location	P7			
Type	USB - A, Stacked USB 3.0 (USB 3.1 Gen 1, Superspeed)			
Carrier Connector	Part Number: 0484060003 Manufacturer: Molex			
Mating Connector	Any USB 3.0 Type-A Cable			
Pinout	Pin	Description	Pin	Description
	1,10	VBUS	2,11	USB 2.0 D-
	3,12	USB 2.0 D+	4,13	GND
	5,14	SSRX-	6,15	SSRX+
	7,16	GND	8,17	SSTX-
	9,18	SSTX+		

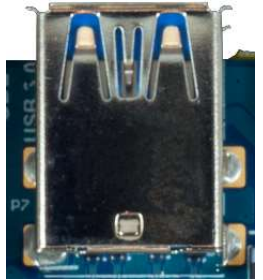
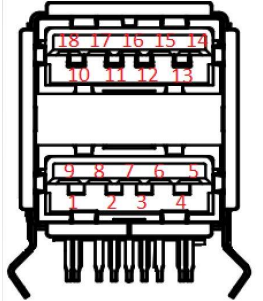
| **Notes** | The Quasar Carrier provides two external USB 3.0 Ports with an integrated USB 2.0 Port. The USB 3.0 signals are sourced directly from the Jetson TX2/TX2i/TX1/TX2-4GB Module. Over current protection, power supply filtering and ESD protection is provided on-board. The current limit on these ports is set to 1.4A, if more current capacity is required please contact sales@connecttech.com **NOTE: Please note that USB3.0 support is NOT natively supported by the stock L4T builds. For USB3.0 support users must deploy CTI-L4T BSP** | | | |



USB OTG

Function	USB OTG			
Location	P8			
Type	USB 2.0 Micro-AB			
Carrier Connector	Part Number: 47589-0001 Manufacturer: Molex			
Mating Connector	Any USB 2.0 Micro A or Micro B or Cable			
Pinout	Pin	Description	Pin	Description
	1	VBUS	2	USB 2.0 D-
	3	USB 2.0 D+	4	USB ID
	5	GND		

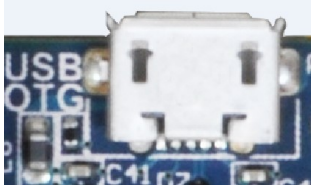

1 2 3 4 5

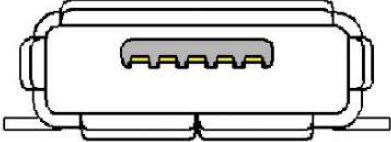

USB OTG – Host Mode

To put the USB OTG port into HOST mode, the USB ID pin needs to be left floating. Most USB Micro-A to Type-A (Female) cables will do this internally.

USB OTG – Client Mode (Used for Image Flashing)

To put the USB OTG port into CLIENT mode, the USB ID pin needs to be tied to GND. Most USB Micro-B cables will do this internally. Once in Client mode this port can then be connected to a Host PC. This is required for software image flashing. Please see the Software Section of this manual for more details.

Input Power

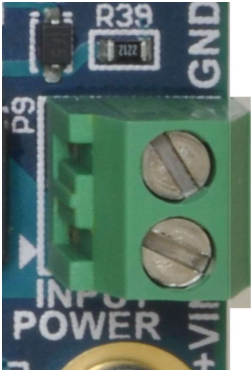
Function	Input Power							
Location	P9							
Type	3.5mm Pitch Wire-to-Board Screw Terminal							
P/N	Texas Instruments 1546551-2							
Mating	Stripped and Tinned 8-22 AWG Wire							
Cable	MSG087							
Pinout	<table border="1"> <thead> <tr> <th>Pin</th> <th>Description</th> </tr> </thead> <tbody> <tr> <td>1</td> <td>+VIN</td> </tr> <tr> <td>2</td> <td>GND</td> </tr> </tbody> </table>	Pin		Description	1	+VIN	2	GND
Pin	Description							
1	+VIN							
2	GND							
Notes	<p>The Quasar Carrier accepts a single power input to power all on-board devices. A power input range of +9V to +14V is recommended.</p>							

Input Power - Wiring

The positive wire should be connected to the +VIN terminal, and the negative wire should be connected to the GND terminal.

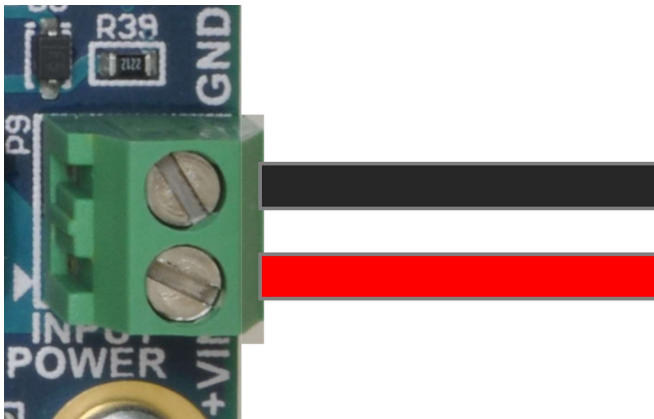

MIPI 1x4 CSI

Function	1x 4-lane MIPI CSI-2 Camera Interface			
Location	P302			
Type	0.4mm pitch, 30 pos, I-PEX connector			
P/N	20525-030E-02C			
Mating	Mating I-PEX cable: FAW1233-03 (300mm)			
Pinout	Pin	Description	Pin	Description
	1	CAM_3.3V	16	CAM_RST#
	2	CAM_3.3V	17	CAM_SDA
	3	CAM_3.3V	18	CAM_SCL
	4	CAM_5V	19	NC
	5	NC	20	DATA2_N
	6	NC (+1.8V)	21	DATA2_P
	7	NC	22	DATA0_N
	8	NC	23	DATA0_P
	9	CAM_PWR#	24	CLK_N
	10	NC	25	CLK_P
	11	NC	26	GND
	12	NC	27	DATA1_N
	13	NC	28	DATA1_P
	14	CAM_FLASH	29	DATA3_N
15	CAM_MCLK	30	DATA3_P	

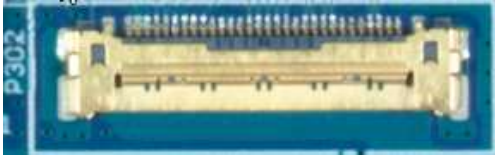

SATA

Function	SATA host	
Location	P300	
Type	7 Position SATA Header, Shrouded Connector	
P/N	Part number: 1546551-2 Manufacturer: Molex	
Mating	Any SATA cable with 7 pin connector	
Pinout	Pin	Description
	1	GND
	2	SATA A TX+
	3	SATA A TX -
	4	GND
	5	SATA B RX -
	6	SATA B RX +
7	GND	
Notes	The Quasar Carrier provides one SATA host connection. Jetson TX2/TX1/TX2i/TX2-4GB only support up to Gen 2.	

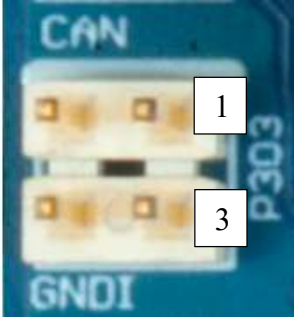

CAN

Function	CAN Connector											
Location	P303											
Type	0.1" / 2.54mm Pitch IDC Header (DIL)											
Carrier Connector	Part Number: HTSW-102-07-G-D Manufacturer: Samtec											
Mating Connector	Any IDC / DIC 0.1" Cable, Socket or Jumper Wire Assemblies											
Pinout	<table border="1"> <thead> <tr> <th>Pin</th> <th>Description</th> </tr> </thead> <tbody> <tr> <td>1</td> <td>CANBUS P</td> </tr> <tr> <td>2</td> <td>GNDI</td> </tr> <tr> <td>3</td> <td>CANBUS N</td> </tr> <tr> <td>4</td> <td>GNDI</td> </tr> </tbody> </table>	Pin		Description	1	CANBUS P	2	GNDI	3	CANBUS N	4	GNDI
Pin	Description											
1	CANBUS P											
2	GNDI											
3	CANBUS N											
4	GNDI											
Notes	Rev A boards are non-isolated CAN. GNDI pins are connected to common GND on the board.											

Switch Details

DIP Switch Details (S1)

The Quasar Carrier has a 2 position DIP switch block which controls the PWM Fan Control and the main Power-up / Start-up Control.

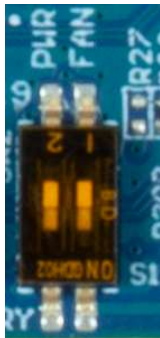

Position No.	Position Description	Switch ON	Switch OFF
1	PWM Fan Control	FAN PWM Enabled (SW Controlled)	FAN Always ON
2	Power-Up / Start-up Control	"AT Mode" - Automatic Start-up Enabled	"ATX Mode" - Power Button Press Required



S1 Usage Examples

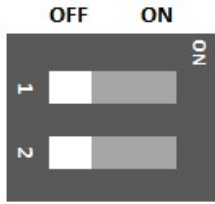

Fan Always ON

"ATX Mode" - Power Button Press Required



FAN PWM Enabled (SW Controlled)

"ATX Mode" - Power Button Press Required



Fan Always ON

"AT Mode" - Automatic Start-up Enabled



FAN PWM Enabled (SW Controlled)

"AT Mode" - Automatic Start-up Enabled

Push Button Details (SW1, SW2, SW3)

The Quasar Carrier has a 3 tactile push buttons - Power (SW1), RESET (SW3) and RECOVERY (SW2).

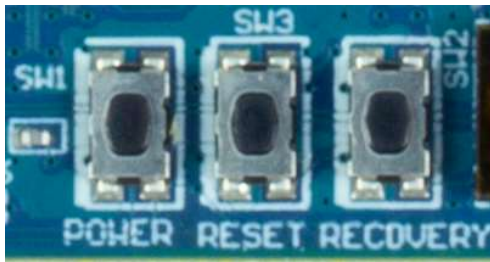

Switch Designator	Description
SW1	<p>Power Button</p> <ul style="list-style-type: none"> - When Quasar is in “ATX Mode” a button press will initiate boot-up sequence - When Quasar is ON, a button press will initiate a power down sequence in the Operating System - When Quasar is ON and button is held for 5 seconds the system will do a hard power off (power down ungracefully) <p>Note: Due to the changes done to the PMIC circuitry of the TX2i Jetson Module the Quasar Carrier will always remain ON when in AT (Automatic Power ON) and ATX (Push Power button) modes. This will cause the Quasar Carrier to automatically power ON when voltage is applied to the system. The system will in addition be unable to shut down in software (Soft Shutdown), due to the characteristics of the TX2i power circuitry as such the system will perform a Reset/Reboot function.</p>
SW3	<p>Reset Button</p> <ul style="list-style-type: none"> - When button is pressed the system will initiate a Reset sequence
SW2	<p>Recovery Button</p> <ul style="list-style-type: none"> - Use this button to perform the Force Recovery Procedure detailed in the Software Section of this manual. - This is required when flashing a new image onto the TX2/TX2i/TX1/TX2-4GB module via the USB OTB port.

Typical Installation

1. Ensure all external system power supplies are off.
2. Install the Jetson TX2/TX2i/TX1/TX2-4GB Module onto the Quasar Carrier as shown below:

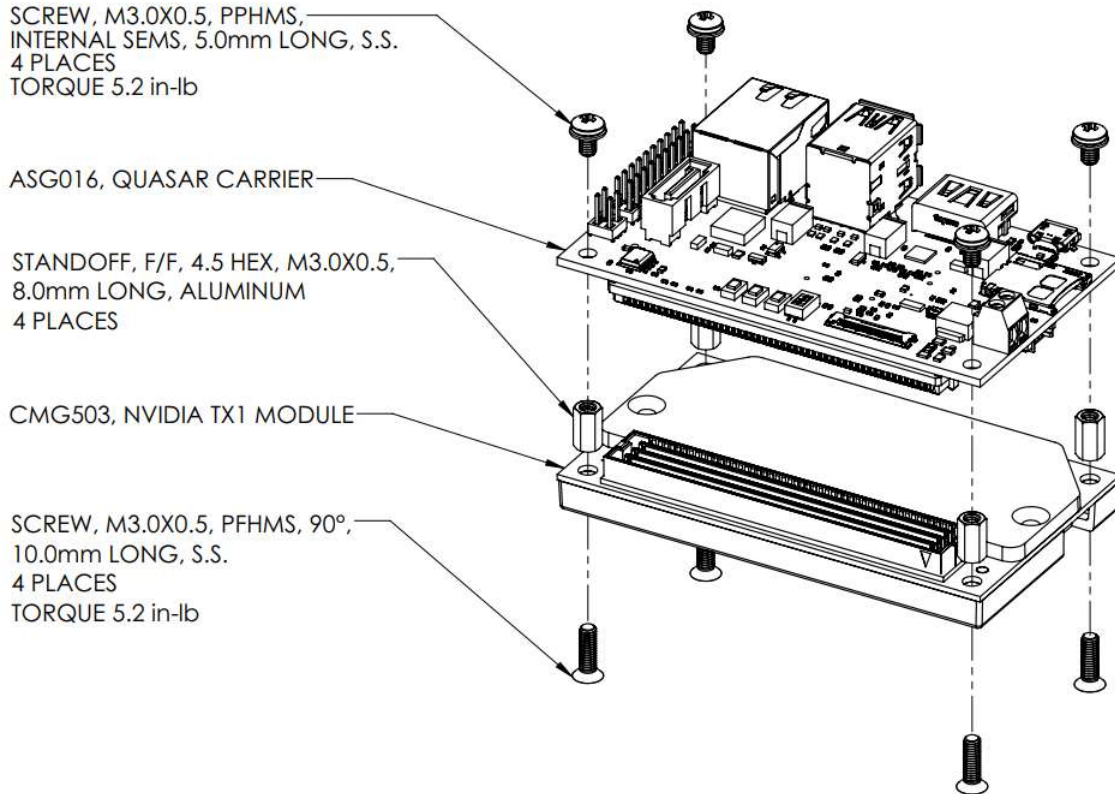

Note: Different screws and standoffs are used for installing TX2-4GB/TX2i:

- a. Standoff, FF, 4.5 Hex, Aluminum, M3.0X0.5, 5mm Long
 - b. Screw, M3.0X0.5, PFHMS, 14.0mm Long, S.S. 4 places (TX2i/TX2-4GB Module side)
3. Install the necessary cables for application. At a minimum these would include:
 - a. HDMI video display cable
 - b. Keyboard and mouse via USB

For additional information on the relevant cables, please see the Cables and Interconnects section of this manual.

4. Connect the main power input to the Wire-to-Board Screw Terminal on board as shown below:
+9V to +14V to the +VIN terminal and Ground to the GND terminal.

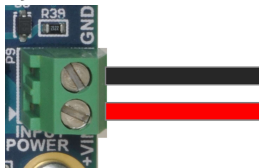

Switch ON the Power Supply. DO NOT power up your system by plugging in live power.



Power Supply

Connect Tech offers 12V power supplies preconfigured for the ASG016. It is supplied by a standard AC line cord and has a cable length of approximately 1.5m. Contact our sales department about the **MSG087** for more details.

Please visit <http://connecttech.com/cables> for drawings.

On-Board Indicator LED's

The Quasar Carrier has 2 on-board indicator LEDs.

LED Designator	Description
D11	Power Good Indicator <ul style="list-style-type: none">- If this LED is ON, this indicates that all on-board power supplies are ON and at the proper level.
D2	System Status Indicator <ul style="list-style-type: none">- If this LED is ON, it indicates the TX2/TX2i/TX1/TX2-4GB module has powered ON.



Current Consumption Details

Below are the maximum ratings of the Quasar Carrier.

Theoretical Maximum	Amps	Watts
Theoretical absolute maximum total draw of all functionality on the board	2.5	30.15

Below are measurements taken with the Quasar Carrier running in various configurations. Some values will change depending on what operation or software is installed. Please refer to the module manufacturer's manual for full details on the current consumption of the particular module you are using.

All measurements below are used with +12V applied to the Input Power Connector.

Actual Measurements	Amps	Watts
Quasar Carrier standalone no module installed, powered ON, with no loads	0.088	1.056
Module Installed, Ubuntu in headless mode, remote operation over serial console	0.27	3.24
Module Installed, single HDMI video output, Keyboard, Mouse and Ethernet connected. System sitting at Ubuntu Desktop (GUI) in idle operation	0.42	5.04
Module Installed, single HDMI video output, USB 3.0 Camera Connected, USB OTG connected with Keyboard & Mouse, Ethernet and system running cheese for the USB Camera.	0.6	7.2
Module Installed, single HDMI video output, USB 3.0 Camera Connected (and streaming), USB OTG connected with Keyboard & Mouse, Ethernet, and system running cpu stress test and glxgears GPU test	0.71	8.52

NOTE: Please make sure that the combined current consumption of all devices using 5V does not exceed 5A total.

Software / BSP Details

All Connect Tech NVIDIA Jetson TX2/TX2i/TX1/TX2-4GB based products are built upon a modified Linux for Tegra (L4T) Device Tree that is specific to each CTI product.

WARNING: The hardware configurations of CTI's products differ from that of the NVIDIA supplied evaluation kit. Please review the product documentation and install ONLY the appropriate CTI L4T BSPs. Failure to follow this process could result in non-functional hardware.

Connect Tech's Custom L4T BSP (CTI-L4T)

Connect Tech also offers a custom BSP to add in additional peripheral support on CTI's Jetson Carrier Boards. In the case of the Quasar Carrier Board the CTI-L4T will expose software control of most of the carrier interfaces including USB3.0, and more.

The CTI-L4T can be downloaded directly from Connect Tech here:

<http://www.connecttech.com/jetson>

NVIDIA Jetpack for L4T

The Jetpack for L4T is an on-demand all-in-one package that bundles and installs all software tools required to develop for the NVIDIA's TX2/TX2i/TX1/TX2-4GB Platform with Connect Tech's TX2/TX2i/TX1/TX2-4GB Carrier Boards. Jetpack includes host and target development tools, APIs and packages (OS images, tools, APIs, middleware, samples, documentation including compiling samples) to enable developers to jump start their development environment for developing with the Jetson Embedded Platform. The latest release of Jetpack runs on an Ubuntu Linux 64-bit host system and supports both the latest Jetson TX2/TX2i/TX1/TX2-4GB Development Kit and Jetson TK1 Development Kit.

NVIDIA's Jetpack can be downloaded directly from NVIDIA here:

<https://developer.nvidia.com/embedded/jetpack>



Force Recovery Mode

To update your system, you will need to be in Force USB Recovery Mode so you can transfer system software to the developer board. When in Force USB Recovery Mode, you are able to update system software and write the boot loader, boot configuration table (BCT), and partition configuration to the device.

See the Platform Software documentation for OS specific instructions when updating system software on your developer board.

CAUTION: ALWAYS CONNECT ALL EXTERNAL PERIPHERAL DEVICES BEFORE CONNECTING THE INPUT POWER SUPPLY

Connecting a device while powered on may damage the Quasar Carrier or peripheral device.

Procedure to place system in Force USB Recovery Mode:

- 1) Power OFF the Quasar. The Quasar MUST be powered OFF, and not in a suspend or sleep state.
- 2) Use a USB Micro-B to USB Type-A Cable. Plug the Micro-B end into the Quasar USB OTG port. Plug the USB Type-A end into a host PC.
- 3) Power ON the Quasar.
- 4) (Press and release the POWER button, if necessary) Press and hold the RECOVERY button; while depressing the RECOVERY button, press and release the RESET button; wait two seconds and release the RECOVERY button.

Note: When in Force USB Recovery Mode, the development system will not boot up (nothing appears on display or serial port).

After successfully updating the system software and restarting your developer board, the system will continue through the boot up process.

Thermal Details

The Quasar Carrier Board has an Operating Temperature Range of -40°C to +85°C.

However, it is important to note that the NVIDIA Jetson TX2 and TX1 Modules have its own properties separate to that of the Quasar Carrier Board. The NVIDIA Jetson TX2i matches the Quasar Operating Temperature Range of -40°C to +85°C.

Customer responsibility requires proper implementation of a thermal solution that maintains the TX2/TX2i/TX1/TX2-4GB SoC and Thermal Transfer Plate (TTP) temperatures below the specified temperatures (shown in the tables below) under the maximum thermal load and system conditions for their use case.

Jetson TX2i Thermal Specifications

Parameter	Value	Units
Maximum TTP operating temperature	85	°C
Recommended Tegra X2 operating temperature limit	T.cpu = 95.5	°C
	T.gpu = 95.5	°C
Tegra X2 maximum operating temperature limit	T.cpu = 101	°C
	T.gpu = 101	°C
	T.diode = 110	°C

Jetson TX2/TX1 Thermal Specifications

Parameter	Value	Units
Maximum TTP operating temperature	80	°C
Recommended Tegra X2 operating temperature limit	T.cpu = 95.5	°C
	T.gpu = 93.5	°C
Tegra X2 maximum operating temperature limit	T.cpu = 101	°C
	T.gpu = 101	°C

NVIDIA provides complete Thermal Design Guides, which include all of the information required to implement a complete thermal solution for the Jetson TX2, TX2i, TX2-4GB or TX1 Module. The Thermal Design Guides can be downloaded here:

Jetson TX2i:

<http://developer.nvidia.com/embedded/dlc/jetson-tx2i-thermal-design-guide>

Jetson TX2/TX1:

<http://developer.nvidia.com/embedded/dlc/jetson-tx2-thermal-design-guide>

Mechanical Details

3D STEP Model

A complete **3D STEP Model** file of the Quasar Carrier can be found here:

http://connecttech.com/ftp/3d_models/ASG016_3D_MODEL.zip

2D Dimensions Drawing

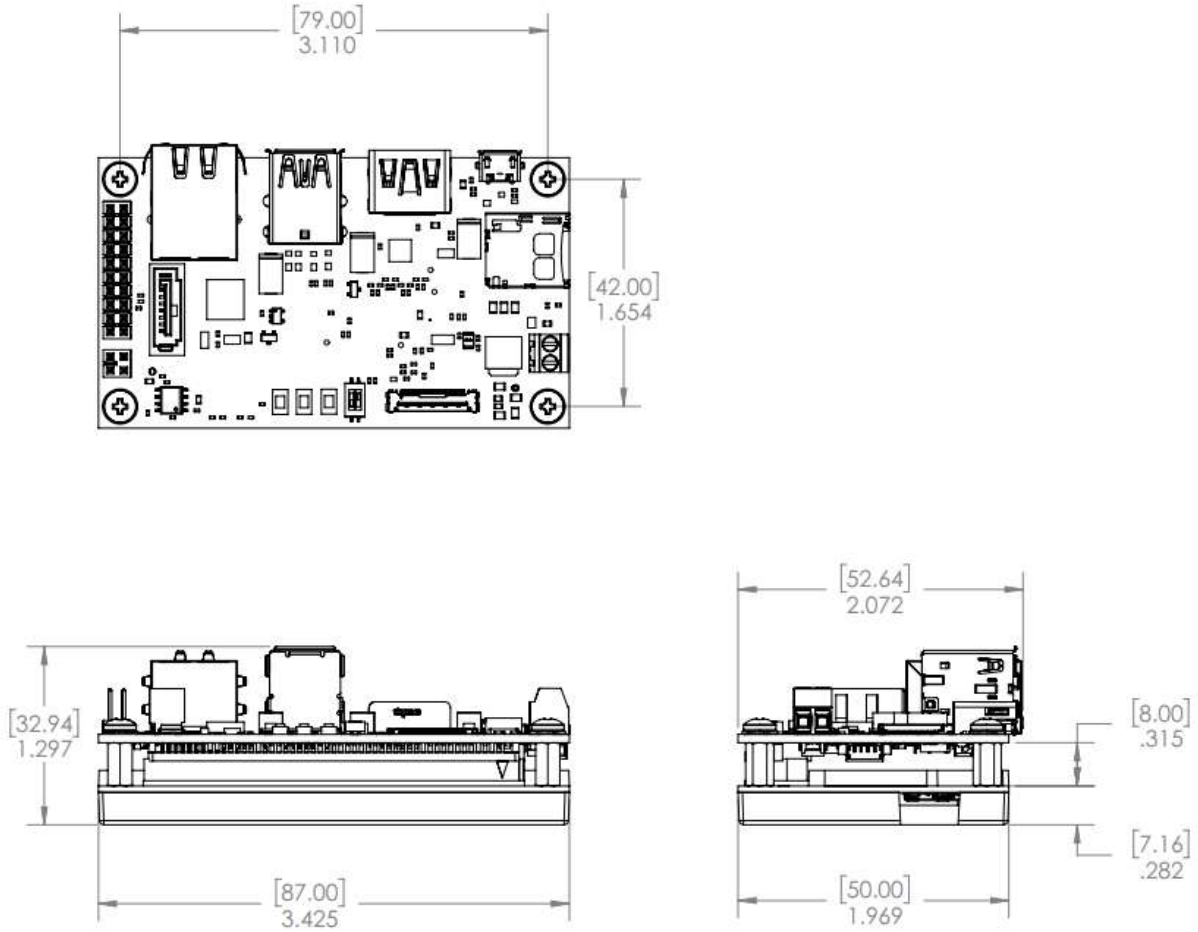

Stack-up Drawing

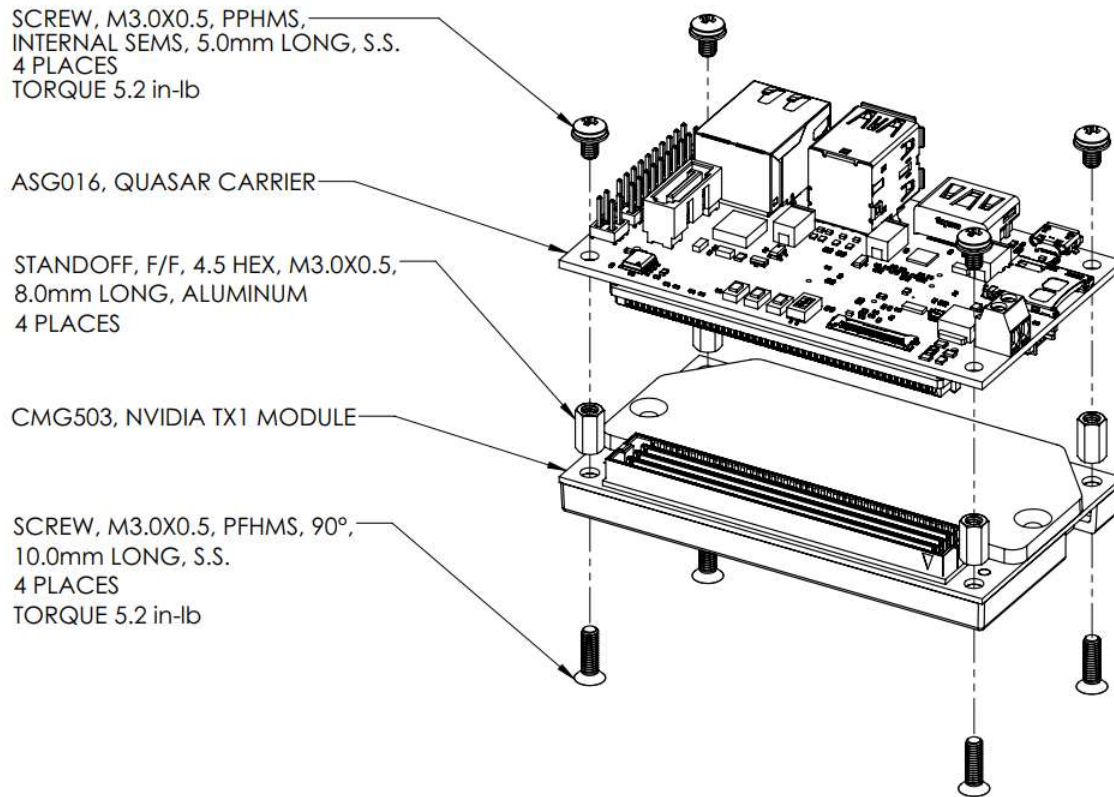

Note: Different screws and standoffs are used for installing **TX2-4GB/TX2i:**

- a. Standoff, FF, 4.5 Hex, Aluminum, M3.0X0.5, 5mm Long
- b. Screw, M3.0X0.5, PFHMS, 14.0mm Long, S.S. 4 places (TX2i/TX2-4GB Module side)



Cables

The Quasar Carrier does not require any special external I/O cables. Standard USB, HDMI and Ethernet Cabling can be used.

Connect Tech offers 12V 5A power supplies preconfigured for the ASG016. It is supplied by a standard AC line cord and has a cable length of approximately 1.5m. Contact our sales department about the **MSG087** for more details.

Related Part Numbers

Product Name	Part Number
Quasar Carrier Board	ASG016
NVIDIA® Jetson™ TX2i	CMG508
NVIDIA® Jetson™ TX2	CMG503-21
NVIDIA® Jetson™ TX1	CMG503
Active Heat Sink	XHG302
Passive Heat Sink	XHG301
SMA Cable – Female, U.FL	CBG225
MSG066	Dual Band Antenna

* All products sold separately