

## Getting started with the P-NUCLEO-LRWAN2 and P-NUCLEO-LRWAN3 starter packs

### Introduction

This user manual describes how to get started with the **P-NUCLEO-LRWAN2** and **P-NUCLEO-LRWAN3** starter packs. Hardware and software setups are discussed in detail, together with the setup of supported network and application servers.

The **P-NUCLEO-LRWAN2** starter pack includes:

- A sensor node based on STMicroelectronics **NUCLEO-L073RZ** Nucleo board and **US1<sup>®</sup> I-NUCLEO-LRWAN1** LoRa<sup>®</sup> expansion board
- A LoRaWAN<sup>®</sup> gateway based on STMicroelectronics **NUCLEO-F746ZG** Nucleo board and **RisingHF LRWAN\_GS\_HF1** expansion board
- Antennas

The **P-NUCLEO-LRWAN2** starter pack supports the higher frequency bands (868 MHz and 915 MHz).

The **P-NUCLEO-LRWAN3** starter pack includes:

- A sensor node based on STMicroelectronics **NUCLEO-L073RZ** Nucleo board and **RisingHF LRWAN\_NS1** LoRa<sup>®</sup> expansion board
- A LoRaWAN<sup>®</sup> gateway based on STMicroelectronics **NUCLEO-F746ZG** Nucleo board and **RisingHF LRWAN\_GS\_LF1** expansion board
- Antennas

The **P-NUCLEO-LRWAN3** starter pack supports the lower frequency bands (433 MHz and 470 MHz).

This user manual also describes the **I-CUBE-LRWAN** STM32Cube Expansion Package for the sensor node, and the gateway binary software.

**Figure 1. P-NUCLEO-LRWAN2 and P-NUCLEO-LRWAN3 - LoRaWAN<sup>®</sup> sensors and gateways**

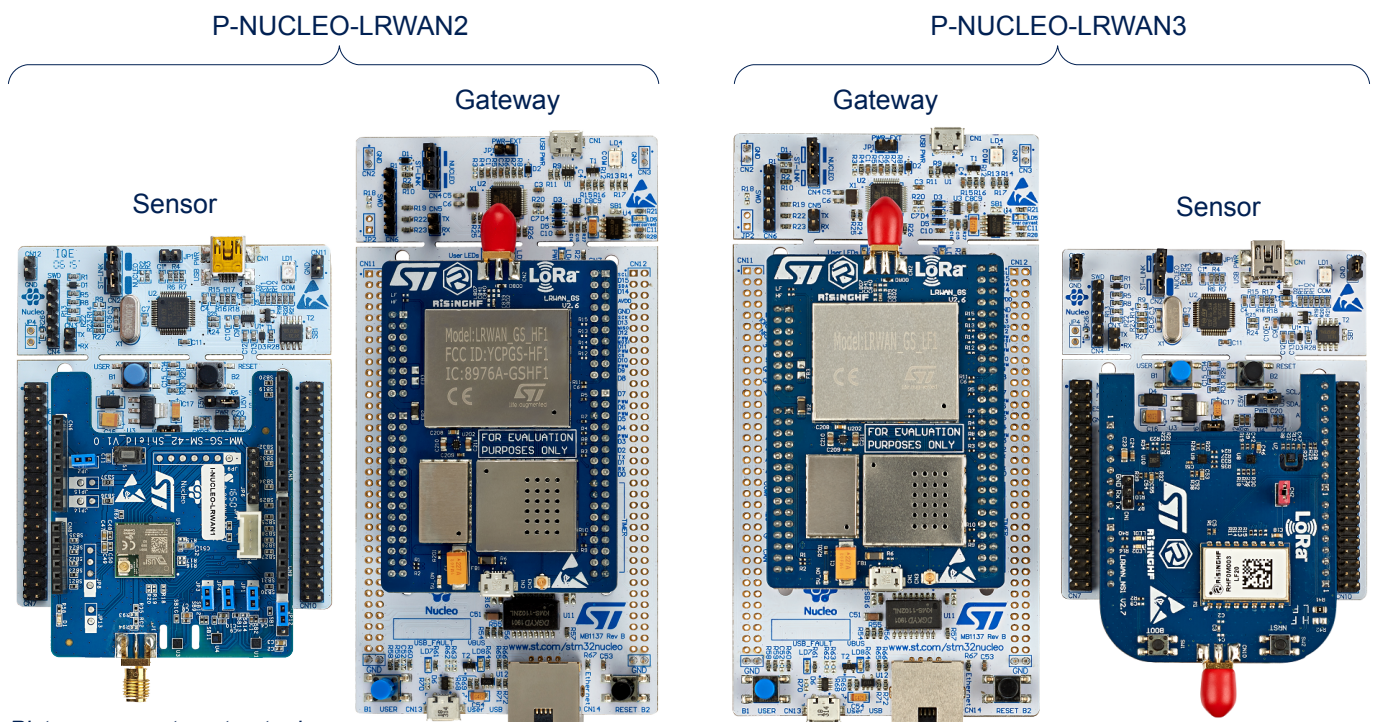

*Pictures are not contractual.*

# 1 P-NUCLEO-LRWAN2 starter pack overview

Figure 2 shows an overview of the P-NUCLEO-LRWAN2 starter pack, which includes a LoRaWAN<sup>®</sup> sensor device and gateway as well as the antennas.

Instructions at the back of the insert card guide the users on how to power up and configure the sensor device and gateway and setup the network.

The starter pack is configured to use the EU868 frequency band with the sensor device in OTAA mode and the gateway forwarding the packets to Lorient EU1 server. The pack is user configurable by firmware and by AT commands.

**Figure 2. STM32 Nucleo LoRaWAN<sup>®</sup> development kit (P-NUCLEO-LRWAN2 starter pack)**



## 1.1 Sensor hardware overview

The P-NUCLEO-LRWAN2 LoRaWAN<sup>®</sup> sensor device has the following key features:

### Main board

- **NUCLEO-L073RZ** development board (from STMicroelectronics)
  - **STM32L073RZT6** Arm<sup>®</sup> Cortex<sup>®</sup>-M0+ ultra-low-power MCU at 32 MHz with 192-Kbyte Flash memory, 20-Kbyte SRAM and 6-Kbyte data EEPROM
  - 1 user LED
  - 1 user and 1 reset push-buttons
  - 32.768 kHz crystal oscillator
  - On-board ST-LINK/V2-1 debugger/programmer with USB re-enumeration capability: mass storage, Virtual COM port, and debug port
  - Board connectors
    - Mini-AB USB connector for the ST-LINK
    - ARDUINO<sup>®</sup> Uno V3 expansion connector
    - ST morpho extension pin headers for full access to all STM32 I/Os

### RF module and sensor expansion board

- **I-NUCLEO-LRWAN1** LoRa<sup>®</sup> HF band (868/915/923 MHz) sensor expansion board (from USI<sup>®</sup>)
  - USI<sup>®</sup> WM-SG-SM-42 low-power long-range LoRaWAN<sup>®</sup> module, based on the STM32L052 MCU and Semtech SX1272 transceiver
  - STMicroelectronics **HTS221** temperature and humidity sensor
  - STMicroelectronics **LPS22HB** pressure sensor
  - STMicroelectronics **LSM303AGR** accelerometer and gyroscope sensor

*Note:* Arm is a registered trademark of Arm Limited (or its subsidiaries) in the US and/or elsewhere.  
All other trademarks are the property of their respective owners.



Figure 3 shows the two boards in the P-NUCLEO-LRWAN2 LoRaWAN<sup>®</sup> sensor device.



Figure 3. STM32 Nucleo LoRaWAN® sensor device (P-NUCLEO-LRWAN2)

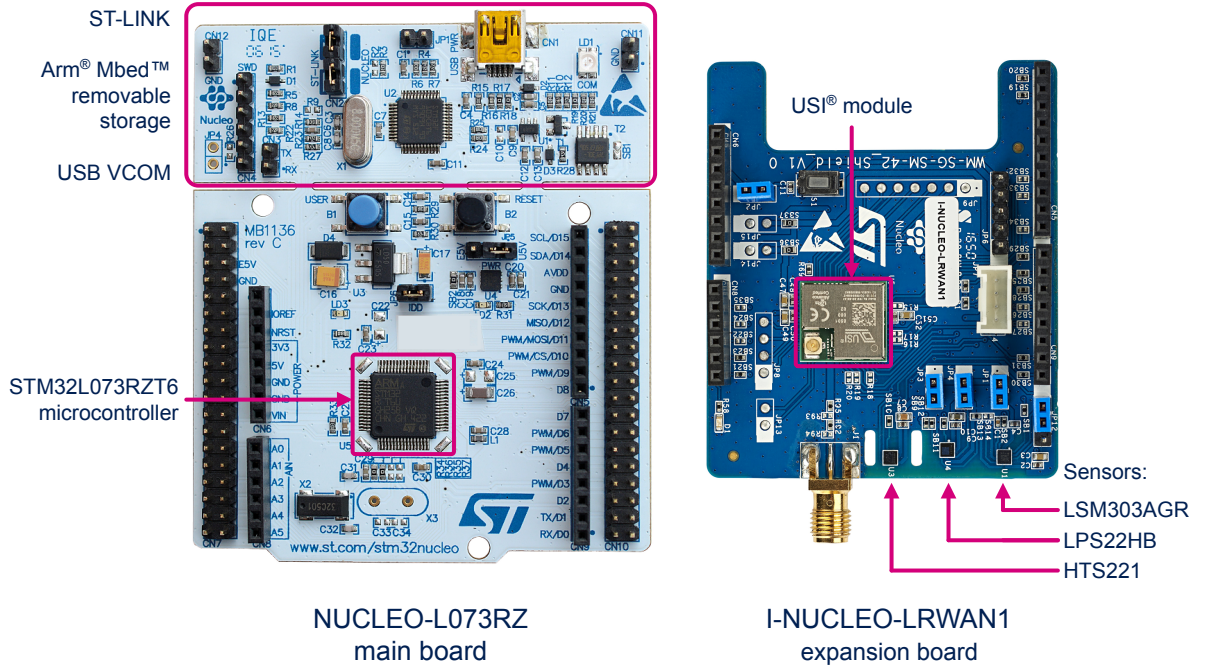



### 1.1.1 I-NUCLEO-LRWAN1 LoRa® HF band and sensor expansion board

The I-NUCLEO-LRWAN1 is supplied by a third party (USI®). For complete and latest information, refer to the third party GitHub page [https://github.com/USILoRaModule/USI\\_I-NUCLEO-LRWAN1](https://github.com/USILoRaModule/USI_I-NUCLEO-LRWAN1).

**Figure 4. I-NUCLEO-LRWAN1 block diagram and connectors**

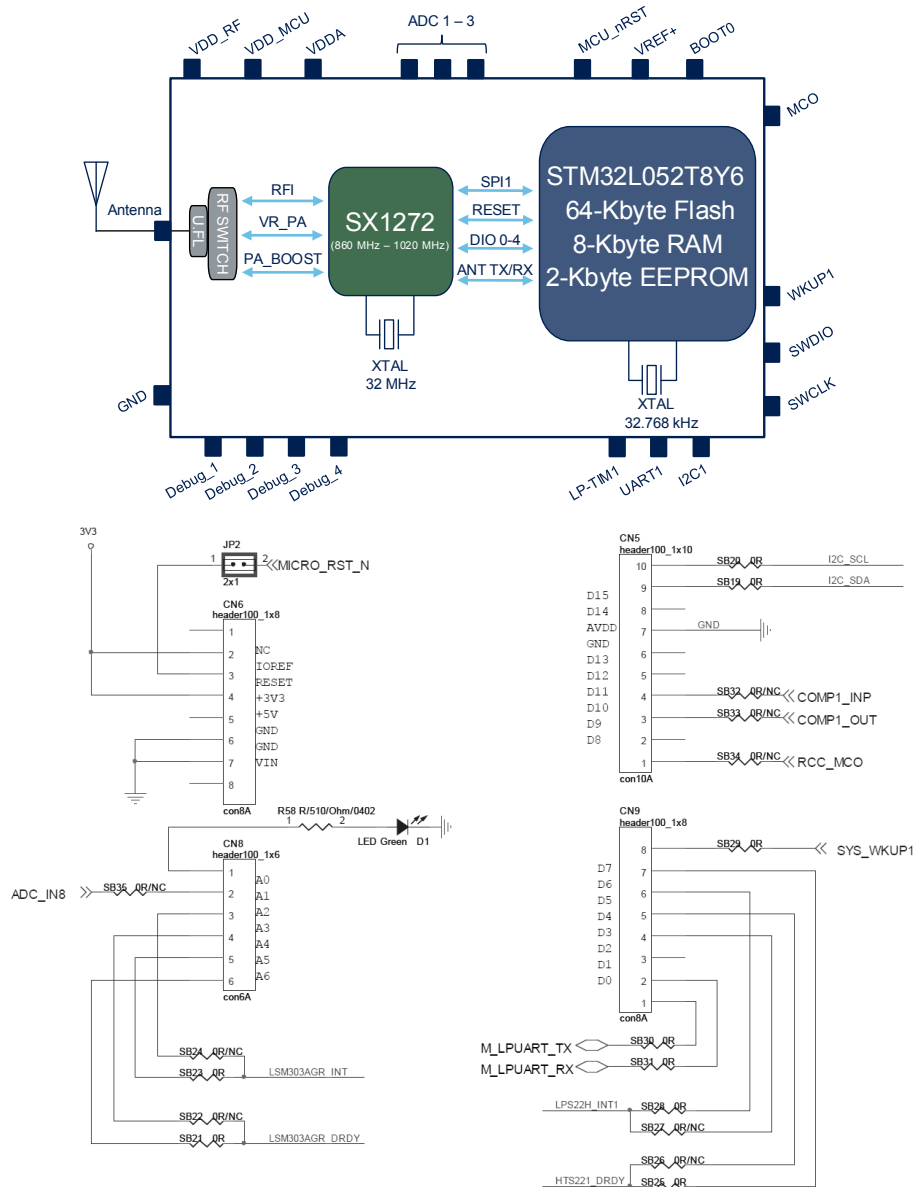

**Note:** The Nucleo board communicates with the expansion board via the STM32 UART (PA2, PA3). The following modifications are applied to the Nucleo board:

- SB62 and SB63 are closed
- SB13 and SB14 are opened to disconnect the STM32 UART from ST-LINK

## 1.2 Gateway hardware overview

The P-NUCLEO-LRWAN2 LoRaWAN® gateway shown in [Section 1.2](#) has the following key features:

### Gateway main board

- **NUCLEO-F746ZG** development board (from STMicroelectronics)
  - **STM32F746ZGT6** Arm® Cortex®-M7 high-performance MCU at 216 MHz with 1-Mbyte Flash memory and 320-Kbyte SRAM
  - 3 user LEDs
  - 1 user and 1 reset push-buttons
  - Ethernet compliant with IEEE-802.3-2002
  - USB OTG full speed or device only
  - 32.768 kHz crystal oscillator
  - On-board ST-LINK/V2-1 debugger/programmer with USB re-enumeration capability: mass storage, Virtual COM port, and debug port
  - Board connectors
    - Micro-AB USB connector for the ST-LINK
    - ST Zio expansion connector including ARDUINO® Uno V3
    - ST morpho extension pin headers for full access to all STM32 I/Os
    - USB with Micro-AB
    - Ethernet RJ45

### Gateway expansion board

- **LRWAN\_GS\_HF1** LoRa® HF band (868/915/923 MHz) gateway expansion board (from RisingHF)
  - **SX1301/SX1257** HF baseband data concentrator and transceiver
    - Automatically adaptive to spreading factor from SF12 to SF7 in each of 8 channels
    - High sensitivity down to -140 dBm at 300 bit/s
    - 6 dBm output power
    - Support LoRaWAN® protocol Class A and Class C
    - Support Semtech packet forwarder
    - Support DNS and NTP

Figure 5. STM32 Nucleo LoRaWAN® gateway (P-NUCLEO-LRWAN2)

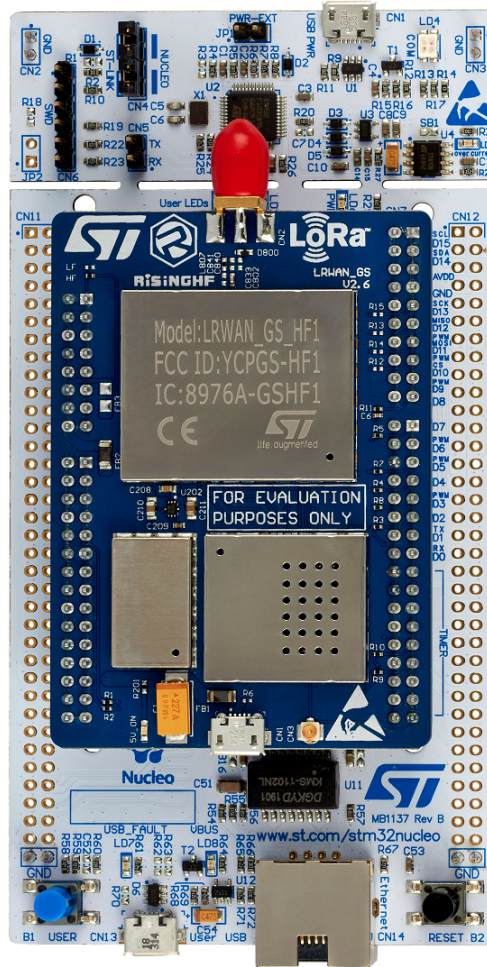

#### Gateway additional features

- Programmable parallel demodulation paths
- LoRa® demodulators and 1 GFSK demodulator embedded
- Single +5 V supply
- AT command interface to re-configure the parameters of the gateway
  - change frequency plan
  - change IP of the gateway
  - change MAC address and ID of the gateway
  - change network server that supports Semtech packet forwarder
  - set to use public server or private server
  - change DNS address
  - change NTP server address



### 1.2.1 Gateway expansion board

The LRWAN\_GS\_HF1 gateway expansion board shown in Figure 6 is designed by RisingHF (www.risinghf.com). It includes a Semtech SX1301 digital baseband circuit integrating the LoRa® concentrator, Semtech SX1257 HF front-end transceiver module, and two SAW filters to achieve a wider bandwidth range (868 MHz to 915 MHz). The expansion board is controlled by the NUCLEO-F746ZG via the SPI interface.

The gateway expansion board includes also an external +5 V power supply circuitry, which powers both the gateway expansion board and NUCLEO-F746ZG development board. The NUCLEO-F746ZG is powered via pin VIN (Pin 15 of connector CN8 on the Nucleo board).

For more details, refer to [3].

**Figure 6. Gateway expansion board (P-NUCLEO-LRWAN2)**

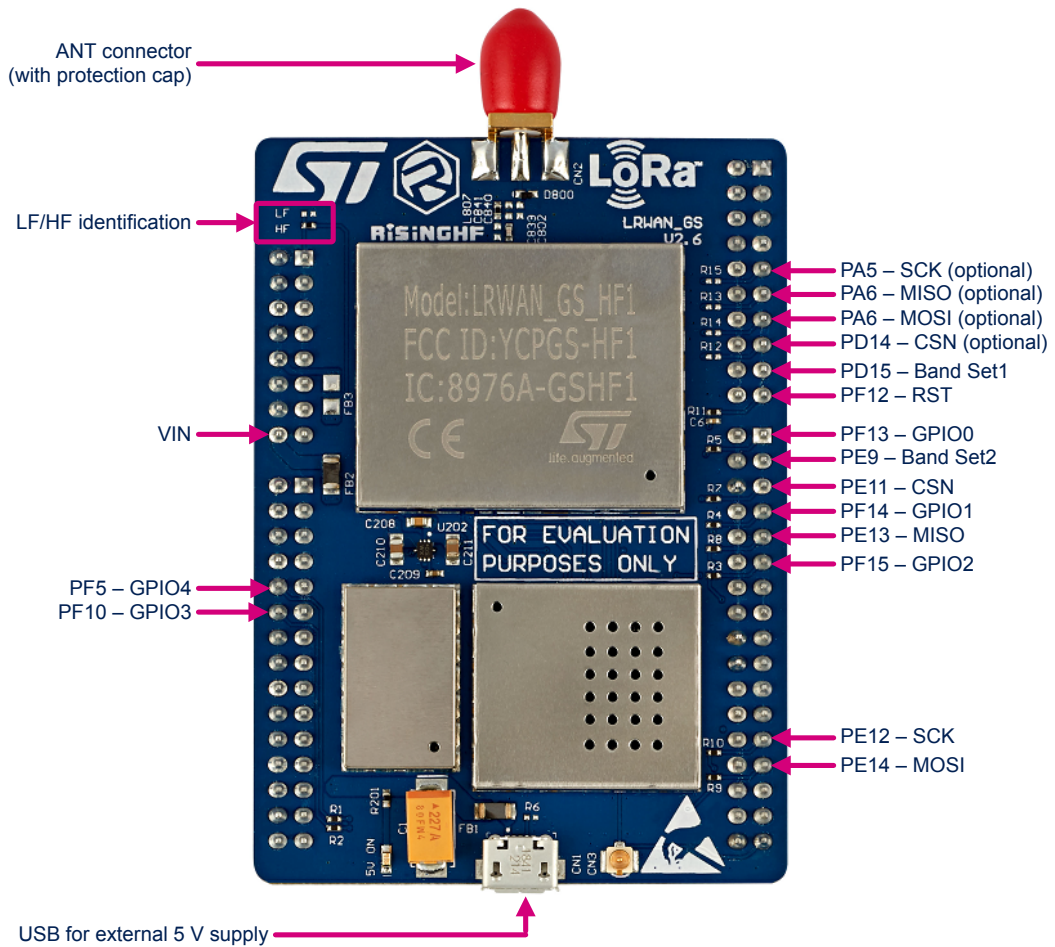

**Table 1. P-NUCLEO-LRWAN2 gateway expansion board pins description**

Pin name	Pin description
VIN	Power supply to NUCLEO-F746ZG from external 5 V
PF5/PD12/PC4/PB9 -GPIO4	GPIO4 from SX1301
PF10/PD13/PC5/PB8 -GPIO3	GPIO3 from SX1301
PF15-GPIO2	GPIO2 from SX1301
PF14-GPIO1	GPIO1 from SX1301
PF13-GPIO0	GPIO0 from SX1301

Pin name	Pin description
PE11-CSN	CSN of SPI for SX1301
PE13-MISO	MISO of SPI for SX1301
PE12-SCK	SCK of SPI for SX1301
PE14-MOSI	MOSI of SPI for SX1301
PE15-RST	Reset for SX1301
PD15-Band Set1	ST Nucleo LoRa GW HF
PE9-Band Set2	<ul style="list-style-type: none"> <li>PE9=0, PD15=1: Band EU868</li> <li>PE9=1, PD15=0: Band US915/AS915/AU915</li> </ul>
PA5-SCK (optional)	Backup SCK of SPI for SX1301 (no connection on board in default)
PA6-MISO (optional)	Backup MISO of SPI for SX1301 (no connection on board in default)
PA7/PB5-MOSI (optional)	Backup MOSI of SPI for SX1301 (no connection on board in default)
PD14-CSN (optional)	Backup CSN of SPI for SX1301 (no connection on board in default)

Figure 7 presents the architecture of the LRWAN\_GS\_HF1 gateway expansion board.

**Figure 7. Hardware architectures of the P-NUCLEO-LRWAN2 gateway expansion board**

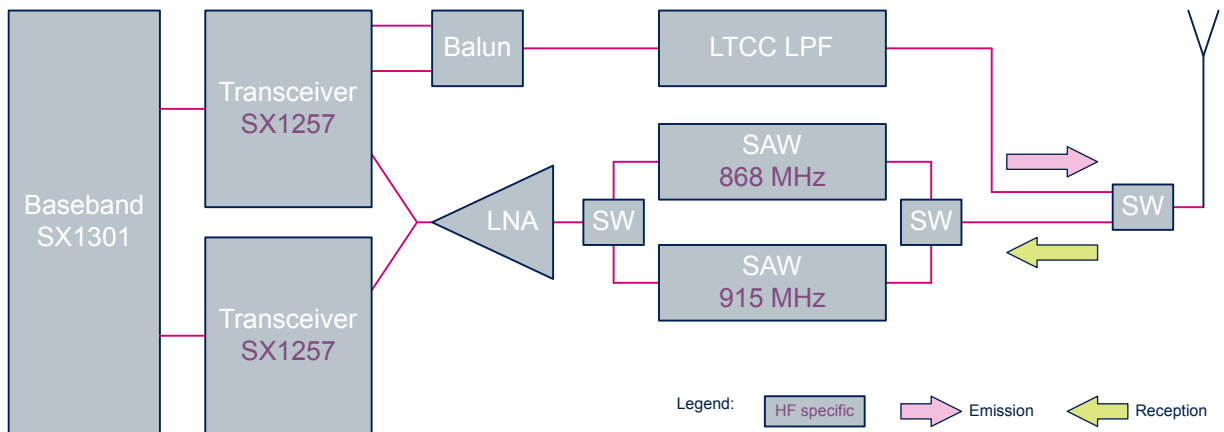

## 2 P-NUCLEO-LRWAN3 starter pack overview

Figure 8 shows an overview of the P-NUCLEO-LRWAN3 starter pack, which includes a LoRaWAN® sensor device and gateway as well as the antennas.

Instructions at the back of the insert card guide the users on how to power up and configure the sensor device and gateway and setup the network.

The starter pack is configured to use the CN470Prequel frequency band with the sensor device in OTAA mode and the gateway forwarding the packets to Lorient CN1 server. The pack is user configurable by firmware and by AT commands.

Figure 8. STM32 Nucleo LoRaWAN® development kit (P-NUCLEO-LRWAN3 starter pack)



### 2.1 P-NUCLEO-LRWAN3 starter pack known limitation

The serial number of the NUCLEO-L073RZ MB1136 reference board is indicated on a sticker under the MB1136. If the number is within the range from A191400001 to A191402004, the board must be updated with a new firmware before use. Download the last firmware version available at [www.st.com/i-cube-lrwan](http://www.st.com/i-cube-lrwan).



## 2.2 Sensor hardware overview

The P-NUCLEO-LRWAN3 LoRaWAN® sensor device has the following key features:

### Main board

- [NUCLEO-L073RZ](#) development board (from STMicroelectronics)
  - [STM32L073RZT6](#) Arm® Cortex®-M0+ ultra-low-power MCU at 32 MHz with 192-Kbyte Flash memory, 20-Kbyte SRAM and 6-Kbyte data EEPROM
  - 1 user LED
  - 1 user and 1 reset push-buttons
  - 32.768 kHz crystal oscillator
  - On-board ST-LINK/V2-1 debugger/programmer with USB re-enumeration capability: mass storage, Virtual COM port, and debug port
  - Board connectors
    - Mini-AB USB connector for the ST-LINK
    - ARDUINO® Uno V3 expansion connector
    - ST morpho extension pin headers for full access to all STM32 I/Os

### RF module and sensor expansion board

- [LRWAN\\_NS1](#) LoRa® LF band (433/470 MHz) sensor expansion board (from RisingHF)
  - RisingHF RHF0M003-LF20 low-power long-range LoRaWAN® module, based on the STM32L071 MCU and Semtech SX1278 transceiver
    - High sensitivity down to -137 dBm
    - 14 dBm to 20 dBm output power
  - STMicroelectronics [HTS221](#) temperature and humidity sensor
  - STMicroelectronics [LPS22HB](#) pressure sensor
  - STMicroelectronics [LSM6DS3](#) accelerometer and gyroscope sensor
  - STMicroelectronics [LIS3MDL](#) magnetometer

[Figure 9](#) shows the two boards in P-NUCLEO-LRWAN3 LoRaWAN® sensor device.

Figure 9. STM32 Nucleo LoRaWAN® sensor device (P-NUCLEO-LRWAN3)

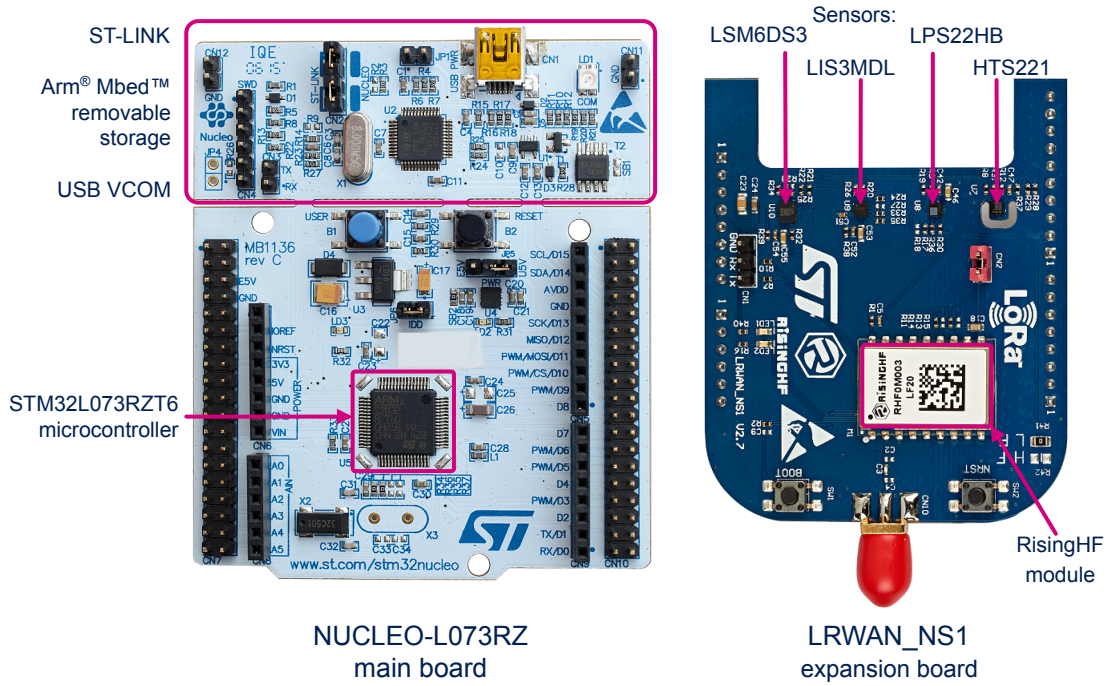

### 2.2.1 LRWAN\_NS1 LoRa® LF band and sensor expansion board

The LRWAN\_NS1 is supplied by a third party (RisingHF). For complete and latest information, refer to LRWAN\_NS1 reference manual [2].

**Figure 10. LRWAN\_NS1 block diagram and connectors**

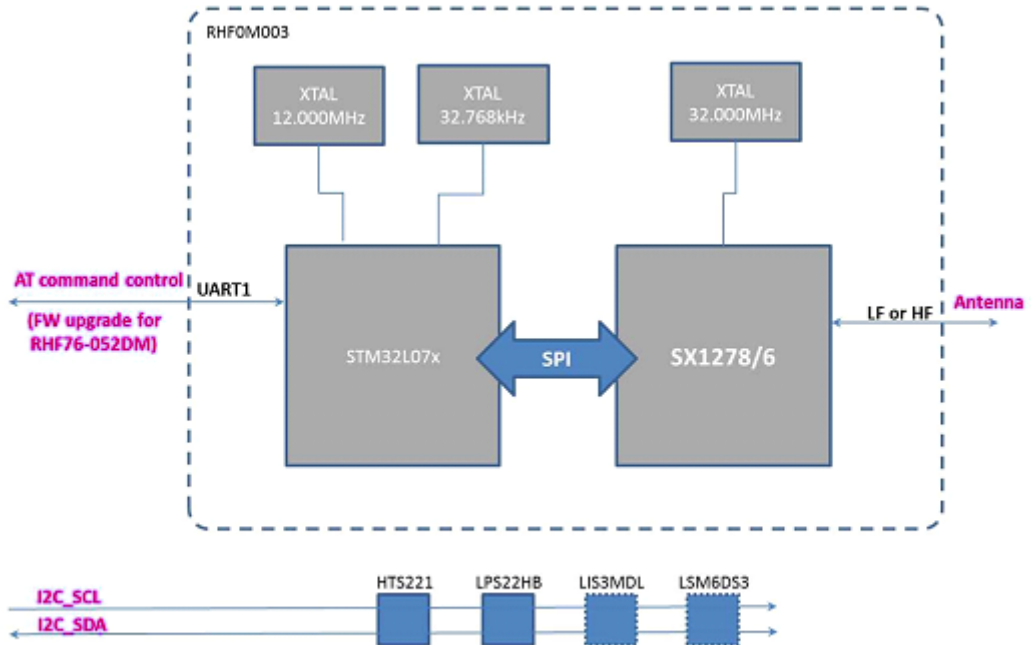

#### mbed compatible connectors:

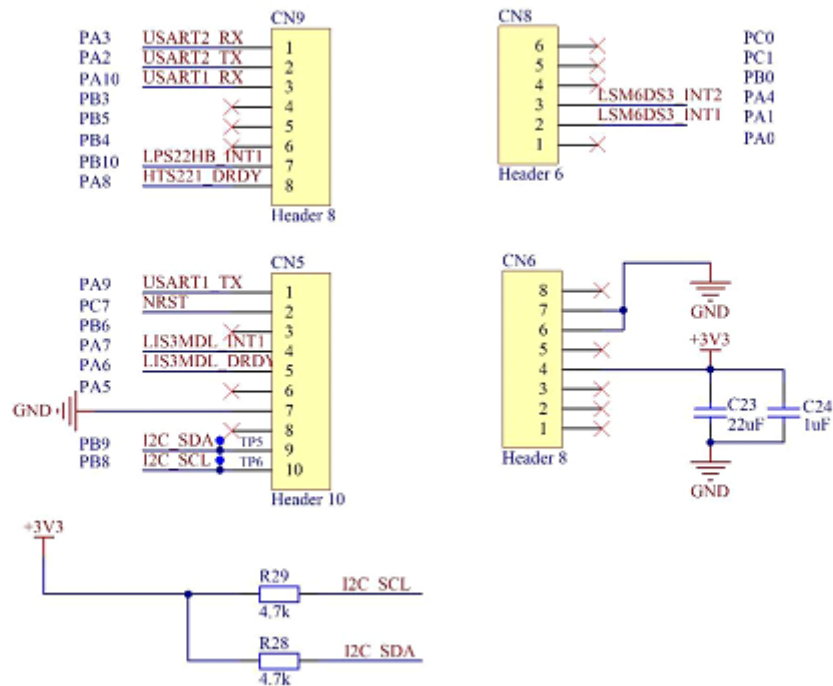



**Note:** By default, USART1 (PA9/PA10) is used in the NUCLEO-L073RZ board to control the RHF0M003-LF20 modem. Optionally, it is possible to use USART2 (PA2/PA3) via jumper resistor on the LRWAN\_NS1. Refer to its user manual. If USART2 (PA2/PA3) is used to control the modem, the following solder bridge on the Nucleo board must be configured accordingly:

- SB62 and SB63 are closed
- SB13 and SB14 are opened to disconnect the STM32 UART from ST-LINK

Refer to [5] in the USART Communication section for more details.

## 2.3 Gateway hardware overview

The P-NUCLEO-LRWAN3 LoRaWAN® gateway shown in Figure 11 has the following key features:

### Gateway main board

- NUCLEO-F746ZG development board (from STMicroelectronics)
  - STM32F746ZGT6 Arm® Cortex®-M7 high-performance MCU at 216 MHz with 1-Mbyte Flash memory and 320-Kbyte SRAM
  - 3 user LEDs
  - 1 user and 1 reset push-buttons
  - Ethernet compliant with IEEE-802.3-2002
  - USB OTG full speed or device only
  - 32.768 kHz crystal oscillator
  - On-board ST-LINK/V2-1 debugger/programmer with USB re-enumeration capability: mass storage, Virtual COM port, and debug port
  - Board connectors
    - Micro-AB USB connector for the ST-LINK
    - ST Zio expansion connector including ARDUINO® Uno V3
    - ST morpho extension pin headers for full access to all STM32 I/Os
    - USB with Micro-AB
    - Ethernet RJ45

### Gateway expansion board

- LRWAN\_GS\_LF1 LoRa® LF band (433/470 MHz) gateway expansion board (from RisingHF)
  - Semtech SX1301/SX1255 LF baseband data concentrator and transceiver
    - Automatically adaptive to spreading factor from SF12 to SF7 in each of 8 channels
    - High sensitivity down to -140 dBm at 300 bit/s
    - 6 dBm output power
    - Support LoRaWAN® protocol Class A and Class C
    - Support Semtech packet forwarder
    - Support DNS and NTP

Figure 11. STM32 Nucleo LoRaWAN® gateway (P-NUCLEO-LRWAN3)

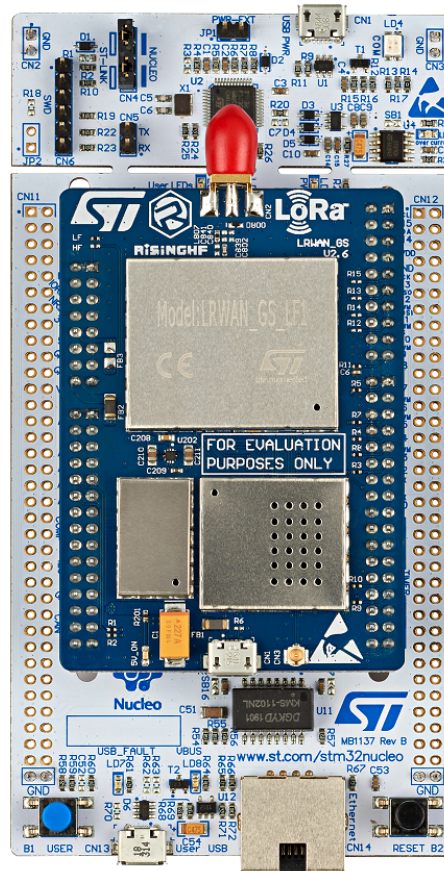

#### Gateway additional features

- Programmable parallel demodulation paths
- LoRa® demodulators and 1 GFSK demodulator embedded
- Single +5 V supply
- AT command interface to re-configure the parameters of the gateway
  - change frequency plan
  - change IP of the gateway
  - change MAC address and ID of the gateway
  - change network server that supports Semtech packet forwarder
  - set to use public server or private server
  - change DNS address
  - change NTP server address

### 2.3.1 Gateway expansion board

The gateway expansion board shown in is designed by RisingHF ([www.risinghf.com](http://www.risinghf.com)). It includes a Semtech SX1301 digital baseband circuit integrating the LoRa® concentrator, Semtech SX1255 LF front-end transceiver module, and two SAW filters to achieve a wider bandwidth range (434 MHz to 470 MHz). The expansion board is controlled by the **NUCLEO-F746ZG** via the SPI interface.

The gateway expansion board includes also an external +5 V power supply circuitry, which powers both the gateway expansion board and NUCLEO-F746ZG development board. The NUCLEO-F746ZG is powered via pin VIN (Pin 15 of connector CN8 on the Nucleo board).

For more details, refer to [3].

**Figure 12. Gateway expansion board (P-NUCLEO-LRWAN3)**

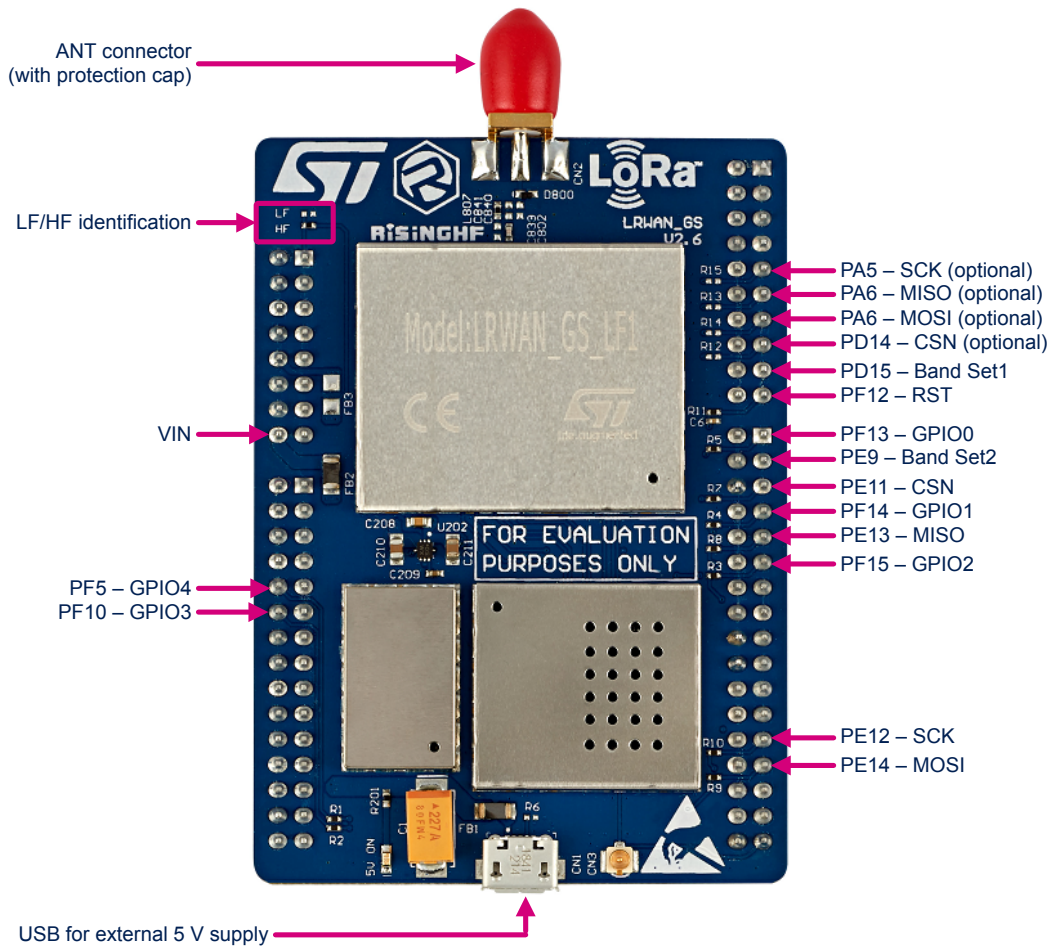

**Table 2. P-NUCLEO-LRWAN3 gateway expansion board pins description**

Pin name	Pin description
VIN	Power supply to NUCLEO-F746ZG from external 5 V
PF5/PD12/PC4/PB9 -GPIO4	GPIO4 from SX1301
PF10/PD13/PC5/PB8 -GPIO3	GPIO3 from SX1301
PF15-GPIO2	GPIO2 from SX1301
PF14-GPIO1	GPIO1 from SX1301
PF13-GPIO0	GPIO0 from SX1301



Pin name	Pin description
PE11-CSN	CSN of SPI for SX1301
PE13-MISO	MISO of SPI for SX1301
PE12-SCK	SCK of SPI for SX1301
PE14-MOSI	MOSI of SPI for SX1301
PE15-RST	Reset for SX1301
PD15-Band Set1	ST Nucleo LoRa GW LF <ul style="list-style-type: none"> <li>• PE9=0, PD15=1: band EU433</li> <li>• PE9=1, PD15=0: band CN470</li> </ul>
PE9-Band Set2	
PA5-SCK (optional)	Backup SCK of SPI for SX1301 (no connection on board in default)
PA6-MISO (optional)	Backup MISO of SPI for SX1301 (no connection on board in default)
PA7/PB5-MOSI (optional)	Backup MOSI of SPI for SX1301 (no connection on board in default)
PD14-CSN (optional)	Backup CSN of SPI for SX1301 (no connection on board in default)

Figure 13 presents the architecture of the LRWAN\_GS\_LF1 gateway expansion board.

**Figure 13. Hardware architecture of the P-NUCLEO-LRWAN3 gateway expansion board**

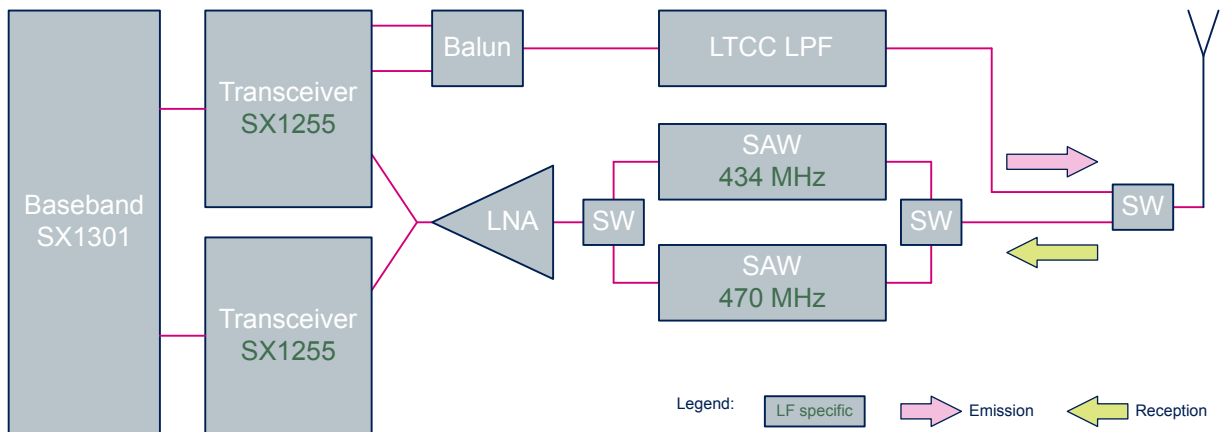

### 3 P-NUCLEO-LRWAN2 / P-NUCLEO-LRWAN3 firmware overview

The [P-NUCLEO-LRWAN2](#) and [P-NUCLEO-LRWAN3](#) starter packs include the following firmware:

- [I-CUBE-LRWAN](#) LoRaWAN® STM32Cube Expansion Package for the microcontrollers in the STM32L0 Series, STM32L1 Series, STM32L4 Series, and STM32L4+ Series
- Binary for the STM32F746ZGT6 microcontroller of the LoRaWAN® gateway Nucleo board

#### 3.1 I-CUBE-LRWAN LoRaWAN® STM32Cube Expansion Package

The [I-CUBE-LRWAN](#) Expansion Package consists of a set of libraries and application examples for STM32L0 Series, STM32L1 Series, STM32L4 Series, and STM32L4+ Series microcontrollers acting as end-devices. This firmware Expansion Package is downloadable from [www.st.com/en/product/i-cube-lrwan](http://www.st.com/en/product/i-cube-lrwan).

A specific firmware project called *AT\_Master* is an example code available only for the STM32L0 Series microcontroller interfacing either with the [I-NUCLEO-LRWAN1](#) US1® LoRa® expansion board, or with the LRWAN\_NS1 RisingHF LoRa® expansion board. The *AT\_Master* sample project implements a host *AT\_Master* application that controls the LoRa® modem via AT commands, establishes a link with the LoRaWAN® network, and sends sensor data.

**Figure 14.** *AT\_Master* in LoRaWAN® STM32Cube Expansion Package

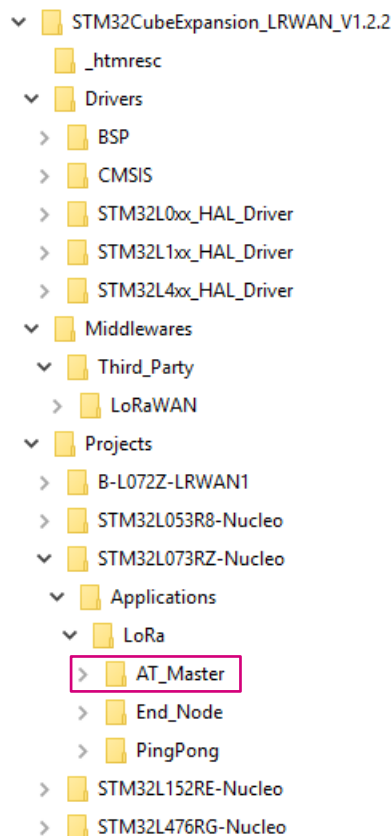

#### 3.2 STM32F7 Nucleo LoRaWAN® gateway firmware

Firmware is based on the Semtech packet forwarder protocol ported over to the STM32F746ZGT6 device. The gateway parameters are fully reconfigurable by means of the AT command interface through the ST-LINK USB Virtual COM port. Refer to [3] for details.

**User reconfigurable parameters by means of the AT command interface**

- Frequency plan
- Network server settings
  - LoRaWAN® server address (public or private)
  - Uplink and downlink port
- Ethernet settings
  - MAC address (default based on STM32 unique ID)
  - Static or DHCP mode
  - IP address, DNS address, NTP server address
- Gateway ID
- Baud rate
- Enabling/disabling log messages

**AT command list**

**Table 3. AT command list**

Command	Comment
AT	Returns +OK.
HELP	Prints help information.
FDEFAULT	Resets to factory default settings.
RESET	Software-reset gateway.
SYS	Checks all configurations.
VER	Gets version.
LOG	Turns on/off packet forwarder log.
ECHO	AT command echo on/off.
MAC	Sets/gets the gateway MAC address.
IP	DHCP/static IP control.
DNS	Sets/gets the DNS address.
NTP	Sets/gets the NTP server address.
EUI	MAC Address (EUI48) to Gateway ID (EUI64) padding.
LORAWAN	LoRaWAN® network selection (public/private).
PKTFWD	Packet forwarder server address and port settings.
CH	Packet forwarder channels.
Baudrate	AT command and logging UART interface baud rate.

The gateway firmware binary is available upon request directly from STMicroelectronics.

To reprogram the board, copy and paste, or drag and drop the binary file to the mbed storage device of the NUCLEO-F746ZG. The STM32 ST-LINK Utility ([STSW-LINK004](#)) programming software is another solution to program the board.

It is recommended to power the board first before connecting the board with the PC. Refer to [Section 6](#) about how to power the board.

**Figure 15. Programming the gateway using a binary file**

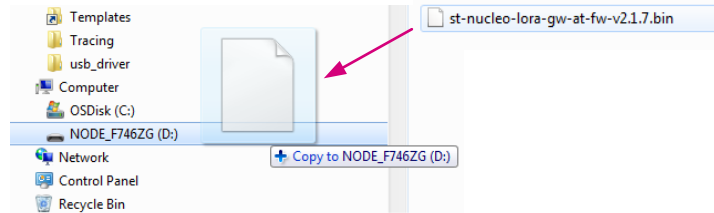

At startup, firmware checks for frequency band setting compatibility versus RF hardware. It displays a warning if the setting is not compatible with the hardware.

## 4 I-NUCLEO-LRWAN1 sensor device setup and reconfiguration

This section describes the steps to setup the **I-NUCLEO-LRWAN1** sensor device and if necessary, reconfigure it to the desired frequency band. By default, the device is configured for the EU868 frequency band and in the OTAA mode.

### 4.1 Sensor device setup

1. Make sure that the USB drivers are installed. Download ST-LINK USB driver (**STSW-LINK009**) from [www.st.com](http://www.st.com) if needed.

Figure 16. ST-LINK driver installation

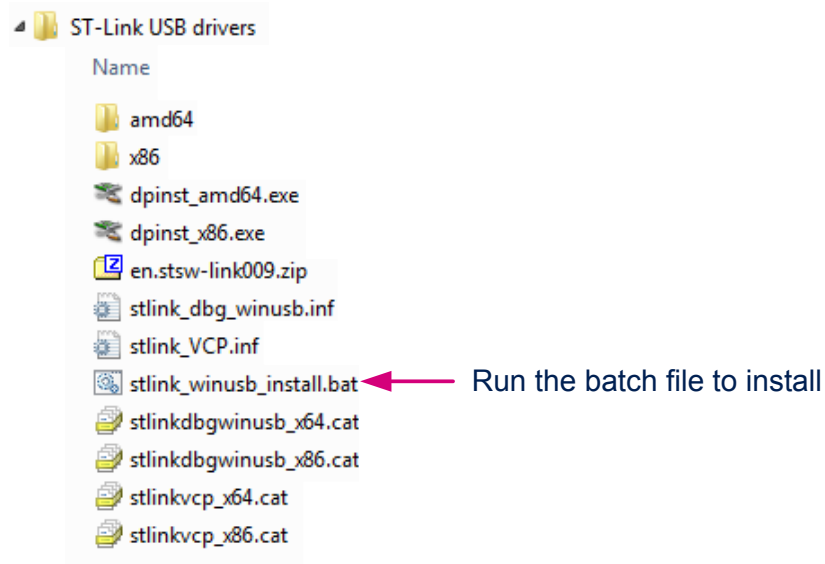

2. On the LoRa<sup>®</sup> expansion board, connect the antenna to connector J1.

Figure 17. Antenna and personal computer connection

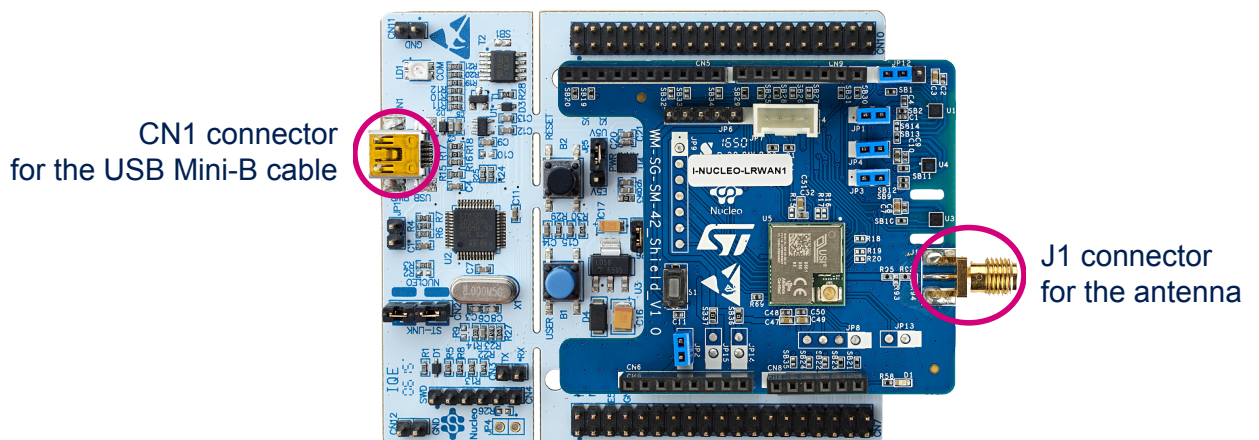

3. Connect the Nucleo board to a personal computer with a USB cable Type-A to Mini-B through USB connector CN1 to the power the board. Then red LED LD3 (PWR) and LD1 (COM) light up.

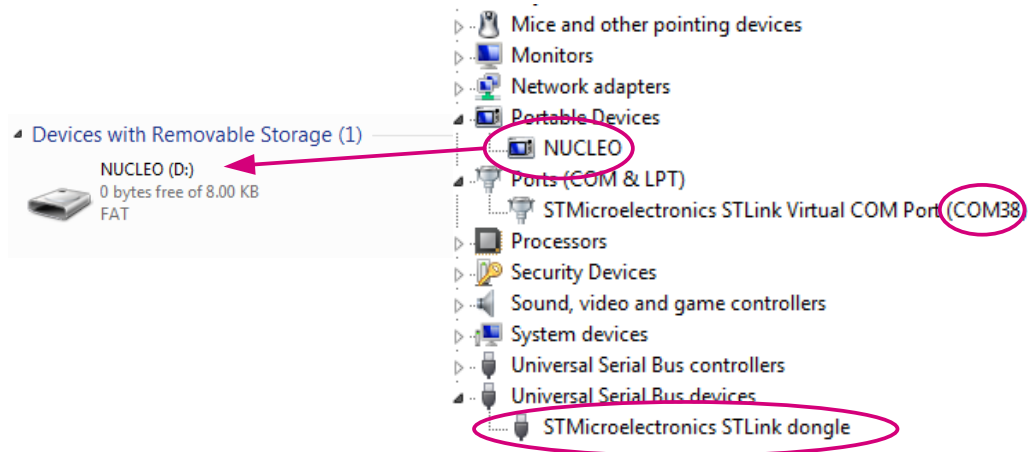

4. Allow the personal computer to enumerate and install the USB drivers.  
 Take note of the Virtual COM port number assigned to the board.  
 Note: the Nucleo board is also enumerated as an mbed removable storage device.

**Figure 18. USB enumerated instances**

## 4.2 Extracting DevEUI and AppEUI from the LoRa® module

Device enrollment to the network server requires activation parameters stored in the LoRa® module. Depending on the join mode used (OTAA/ABP), the pieces of information presented in [Table 4](#) need to be extracted from the LoRa® module (default) or changed.

**Table 4. Device activation and parameters (P-NUCLEO-LRWAN2)**

Parameters	Description	End-device activation
DevEUI	64-bit global unique ID that uniquely identifies the end-device (IEEE EUI64 address).	OTAA
AppEUI	64-bit application ID that uniquely identifies the application provider (owner) of the end-device (IEEE EUI64 address).	
AppKey	AES-128 application key, specific to the end-device, assigned by the application provider, that is used to derive the session keys, <code>NwksKey</code> and <code>AppSKey</code> specific to that end-device to encrypt and verify network communication and application data.	
NwksKey	Network session key, specific to the end-device. Used by the network server and end-device to calculate and verify the MIC (message integrity code) and further encrypt and decrypt the payload field of MAC-only data messages.	ABP
AppSKey	Application session key, specific to the end-device. Used by both the network server and the end-device to encrypt and decrypt the payload field of 30 application-specific data messages.	
DevAddr	32-bit address that identifies the end-device within the current network.	

Send a `get AT` command to extract the default parameters of the US1® WM-SG-SM-42 LoRa® module through its serial port. Refer to [1] for details.

- Get Device EUI (`AT+EUI`)
- Get Application EUI (`AT+APPEUI`)
- Get Application Key (`AT+AK`)

The I-NUCLEO-LRWAN1 expansion board uses the serial interface (CN8 pin 1 (Tx) and pin 2 (Rx)) shown in Figure 19 for the AT command console. The default serial configuration is:

- Baud rate: 115200
- Data: 8 bit
- Parity: none
- Stop: 1 bit

**Figure 19.** I-NUCLEO-LRWAN1 expansion board serial port

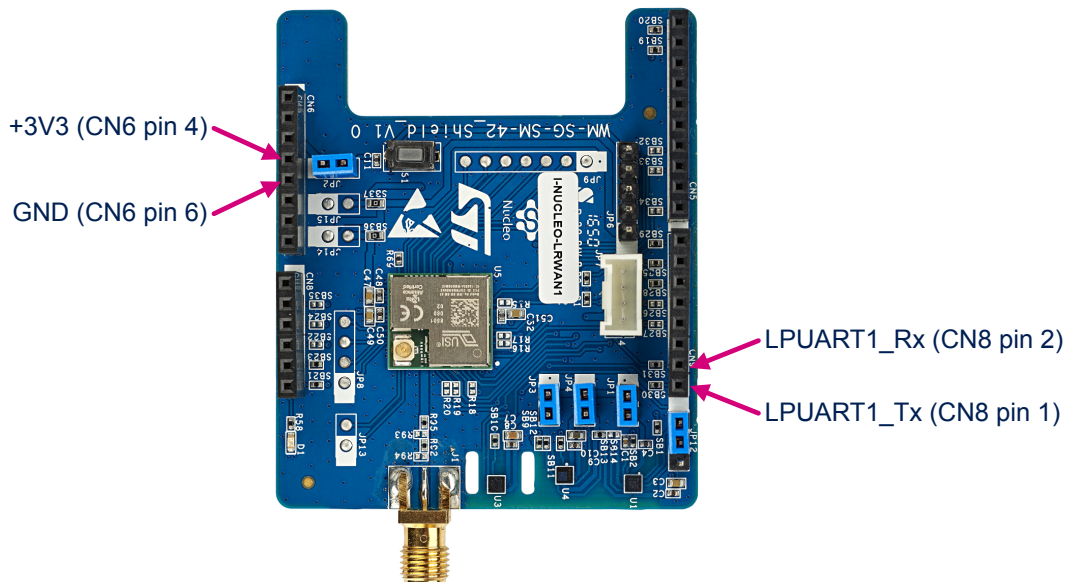

Alternatively, since preloaded firmware reads the `DevEUI` and `AppEUI` parameters of the module and saves them to the internal data memory of the `STM32L073RZT6` (Data Memory Bank 1 of the `NUCLEO-L073RZ` Nucleo board), the user can extract both parameters by reading the data memory using the STM32 ST-LINK Utility (`STSW-LINK004`) or the STM32CubeProgrammer (`STM32CubeProg`).

Follow these steps to extract `DevEUI` and `AppEUI` using the STM32 ST-LINK Utility:

1. Download STM32 ST-LINK Utility (`STSW-LINK004`) from STMicroelectronics web site and install it
2. Connect the `NUCLEO-L073RZ` Nucleo board with the personal computer by means of the USB
3. Open a Windows® *Command* prompt and set the path for the STM32 ST-LINK Utility:  

```
SET PATH=%PATH%;C:\Program Files (x86)\STMicroelectronics\STM32 ST-LINK Utility\ST-LINK Utility
```
4. Read `DevEUI` and `AppEUI` using STM32 ST-LINK Utility CLI command:
  - For `DevEUI`: `ST-LINK_CLI.exe -c swd ur -r8 0x08080000 0x08`
  - For `AppEUI`: `ST-LINK_CLI.exe -c swd ur -r8 0x08080008 0x08`

The addresses in the CLI commands are for Data Memory Bank 1 of the `NUCLEO-L073RZ` Nucleo board.

**Note:** The STM32 ST-LINK Utility (`STSW-LINK004`) GUI can also be used to read the data memory of the `NUCLEO-L073RZ`.

A similar process is possible using the STM32CubeProgrammer (`STM32CubeProg`). Refer to STM32CubeProgrammer documentation on [www.st.com](http://www.st.com).

### 4.3 Reconfiguring the sensor device using the AT\_Master project

Edit firmware to change join mode, frequency band, device IDs, and keys. More parameters are reconfigurable. The following examples show functions used to set these parameters in user firmware.

In file `main.c`:

```
#define JOIN_MODE OTAA_JOIN_MODE /*ABP_JOIN_MODE*/ /*LoRaWan join method*/
```

In file `lora_driver.c`:

- `Lora_SetDeviceBand(uint8_t DeviceBand)` → Sets the band plan
- `LoRa_SetDeviceID(uint8_t *PtrDeviceID)` → Sets the device ID (DevEUI)
- `LoRa_SetAppID(uint8_t *PtrAppID)` → Sets the application identifier (AppEUI)
- `LoRa_SetDeviceAddress(uint32_t DeviceAddr)` → Sets the device address (DevAddr)
- `LoRa_SetKey(ATCmd_t KeyType, uint8_t *PtrKey)` → Sets the key configuration (APPKEY, NWKSKE, APPSKEY)
- `Lora_UpdateConfigTable()` → Updates the DCT content table with new values

The corresponding *Get* functions are also available.

Alternatively, it is possible to reconfigure the WM-SG-SM-42 module directly via its serial port by sending AT commands from the PC. Refer to [1] for details.

Set additional options in the `hw_conf.h` file in folder `AT_Master`:

- Low-power mode: enables/disables the low-power mode
- Sensor-enable switch: enables reading the data from the sensors in the [I-NUCLEO-LRWAN1](#) expansion board

## 5 LRWAN\_NS1 sensor device setup and reconfiguration

This section describes the steps to setup the LRWAN\_NS1 sensor device and if necessary, reconfigure it to the desired frequency band. By default, the device is configured for the CN470Prequel frequency band and in the OTAA mode.

### 5.1 Sensor device setup

1. Make sure that the USB drivers are installed. Download ST-LINK USB driver ([STSW-LINK009](#)) from [www.st.com](http://www.st.com) if needed.

Figure 20. ST-LINK driver installation

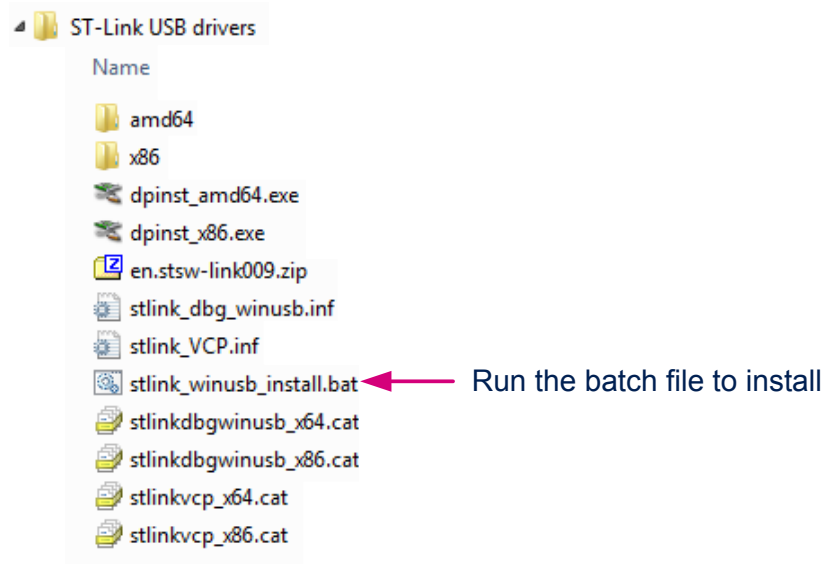

2. On the LoRa® expansion board, connect the antenna to connector CN10.

Figure 21. Antenna and personal computer connection

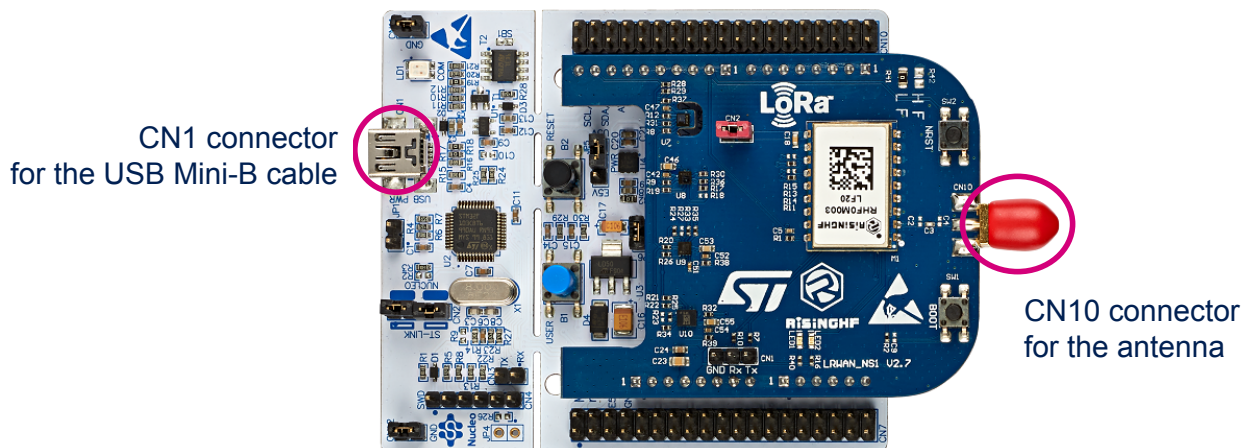

3. Connect the Nucleo board to a personal computer with a USB cable Type-A to Mini-B through USB connector CN1 to the power the board. Then red LED LD3 (PWR) and LD1 (COM) light up.

4. Allow the personal computer to enumerate and install the USB drivers.  
 Take note of the Virtual COM port number assigned to the board.  
 Note: the Nucleo board is also enumerated as an mbed removable storage device.

Figure 22. USB enumerated instances

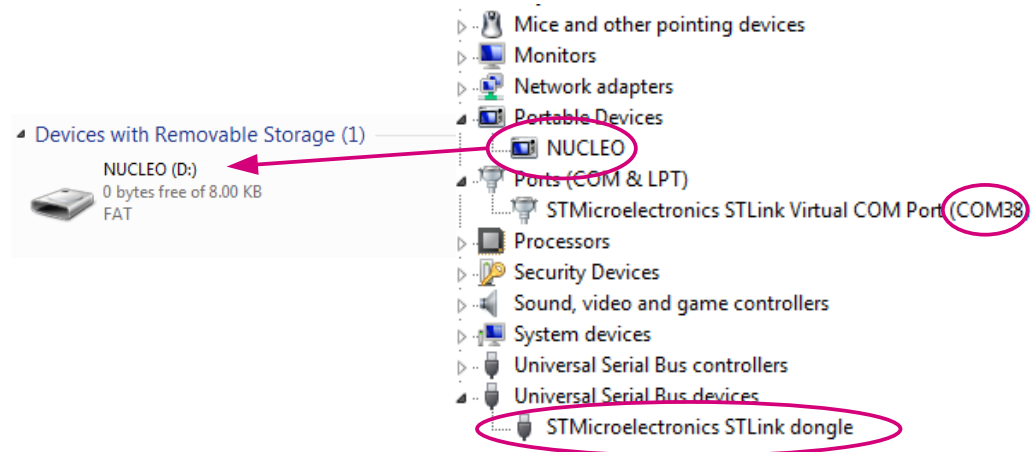

5. [Optional: to display debug printf messages] Open a terminal emulation software such as Tera Term and configure it with the following settings for further viewing of the LoRa® device parameters:
  - Port: (Virtual COM port number assigned to the board from step 4)
  - Baud rate: 9600
  - Data: 8 bit
  - Parity: none
  - Stop: 1 bit

Figure 23. Terminal emulation software settings

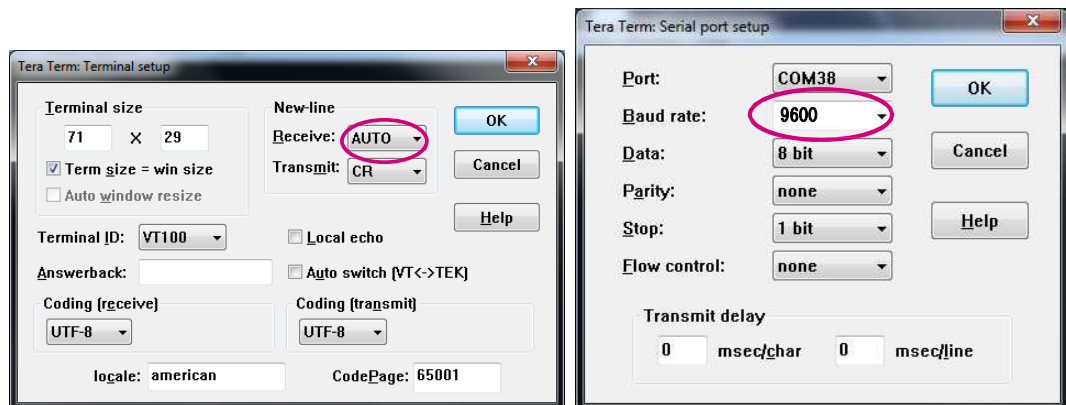

## 5.2 Extracting DevEUI and AppEUI from the LoRa® module

Device enrollment to the network server requires activation parameters stored in the LoRa® module. Depending on the join mode used (OTAA/ABP), the pieces of information presented in Table 5 need to be extracted from the LoRa® module (default) or changed.



**Table 5. Device activation and parameters(P-NUCLEO-LRWAN3)**

Parameters	Description	End-device activation
DevEUI	64-bit global unique ID that uniquely identifies the end-device (IEEE EUI64 address).	OTAA
AppEUI	64-bit application ID that uniquely identifies the application provider (owner) of the end-device (IEEE EUI64 address).	
AppKey	AES-128 application key, specific to the end-device, assigned by the application provider, that is used to derive the session keys, <i>NwkSKey</i> and <i>AppSKey</i> specific to that end-device to encrypt and verify network communication and application data.	
NwkSKey	Network session key, specific to the end-device. Used by the network server and end-device to calculate and verify the MIC (message integrity code) and further encrypt and decrypt the payload field of MAC-only data messages.	ABP
AppSKey	Application session key, specific to the end-device. Used by both the network server and the end-device to encrypt and decrypt the payload field of 30 application-specific data messages.	
DevAddr	32-bit address that identifies the end-device within the current network.	

Send a *get* AT command to extract the default parameters of the RisingHF RHF0M003-LF20 LoRa® module through its serial port. Refer to [2] for details.

- Get Device EUI (*AT+EUI*)
- Get Application EUI (*AT+APPEUI*)
- Get Application Key (*AT+AK*)

The LRWAN\_NS1 LoRa® expansion board uses the serial interface (CN8 pin 1 (Tx) and pin 2 (Rx)) shown in Figure 24 for the AT command console. The default serial configuration is:

- Baud rate: 9600
- Data: 8 bit
- Parity: none
- Stop: 1 bit

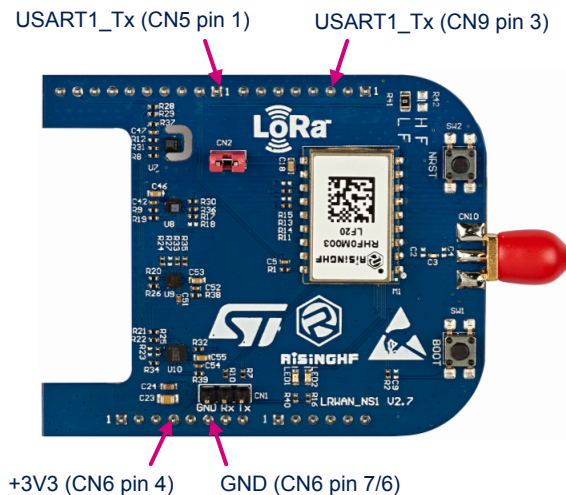
**Figure 24. LRWAN\_NS1 expansion board serial port**

Alternatively, since preloaded firmware reads the `DevEUI` and `AppEUI` parameters of the module and saves them to the internal data memory of the [STM32L073RZT6](#) (Data Memory Bank 1 of the [NUCLEO-L073RZ](#) Nucleo board), the user can extract both parameters by reading the data memory using the STM32 ST-LINK Utility ([STSW-LINK004](#)) or the STM32CubeProgrammer ([STM32CubeProg](#)).

Follow these steps to extract `DevEUI` and `AppEUI` using the STM32 ST-LINK Utility:

1. Download STM32 ST-LINK Utility ([STSW-LINK004](#)) from STMicroelectronics web site and install it
2. Connect the [NUCLEO-L073RZ](#) Nucleo board with the personal computer by means of the USB
3. Open a Windows® *Command* prompt and set the path for the STM32 ST-LINK Utility:
 

```
SET PATH=%PATH%;C:\Program Files (x86)\STMicroelectronics\STM32 ST-LINK Utility\ST-LINK Utility
```
4. Read `DevEUI` and `AppEUI` using STM32 ST-LINK Utility CLI command:
  - For `DevEUI`: `ST-LINK_CLI.exe -c swd ur -r8 0x08080000 0x08`
  - For `AppEUI`: `ST-LINK_CLI.exe -c swd ur -r8 0x08080008 0x08`

The addresses in the CLI commands are for Data Memory Bank 1 of the [NUCLEO-L073RZ](#) Nucleo board.

*Note:* The STM32 ST-LINK Utility ([STSW-LINK004](#)) GUI can also be used to read the data memory of the [NUCLEO-L073RZ](#).

A similar process is possible using the STM32CubeProgrammer ([STM32CubeProg](#)). Refer to [STM32CubeProgrammer](#) documentation on [www.st.com](http://www.st.com).

### 5.3 Reconfiguring the sensor device using the AT\_Master project

Edit firmware to change join mode, frequency band, device IDs, and keys. More parameters are reconfigurable. The following examples show functions used to set these parameters in user firmware.

In file `main.c`:

```
#define JOIN_MODE OTAA_JOIN_MODE /*ABP_JOIN_MODE*/ /*LoRaWan join method*/
```

In file `lora_driver.c`:

- `Lora_SetDeviceBand(uint8_t DeviceBand)` → Sets the band plan
- `LoRa_SetDeviceID(uint8_t *PtrDeviceID)` → Sets the device ID (`DevEUI`)
- `LoRa_SetAppID(uint8_t *PtrAppID)` → Sets the application identifier (`AppEUI`)
- `LoRa_SetDeviceAddress(uint32_t DeviceAddr)` → Sets the device address (`DevAddr`)
- `LoRa_SetKey(ATCmd_t KeyType, uint8_t *PtrKey)` → Sets the key configuration (`APPKEY`, `NWKSKE`, `APPSKEY`)
- `Lora_SetWDT(0)` → triggers a module reset so that the new settings will take effect

The corresponding *Get* functions are also available.

Alternatively, it is possible to reconfigure the RHF0M003-LF20 module directly via its serial port by sending AT commands from the PC. Refer to [\[2\]](#) for details.

Set additional options in the `hw_conf.h` file in folder `AT_Master`:

- Low-power mode: enables/disables the low-power mode
- Sensor-enable switch: enables reading the data from the sensors in the `LRWAN_NS1` expansion board

AT command debug `printf` messages can be sent via ST-LINK Virtual COM port by:

- enabling the definition of `CMD_DEBUG` in the toolchain preprocessor symbols settings,
- or adding the line

```
#define CMD_DEBUG
```

in the user file (e.g. `main.c`).

## 6 Gateway setup and configuration

The gateway is a simple packet forwarder based on the Semtech packet forwarder protocol. It needs to be configured to the desired frequency band and LoRaWAN® network server among other parameters that are reconfigurable. This can be done by sending AT commands using the Virtual COM port of the Nucleo board. This section describes the steps to setup the gateway and reconfigure it to the desired frequency band and network server that supports the Semtech packet forwarder protocol.

### 6.1 Gateway setup

1. On the [NUCLEO-F746ZG](#) board, verify the jumper settings:
  - JP1 (PWR-EXT) OFF
  - JP3 (power source) on VIN-5V
  - JP5 (IDD) ON
2. Connect the NUCLEO-F746ZG board to a network router with an Ethernet cable through Ethernet connector CN14.  
*Make sure that the router has DHCP service and Internet access (no password).*
3. Connect the antenna to the antenna connector (CN2).
4. On the LoRa® gateway expansion board, connect an external 5 V supply through its USB Micro-B connector (CN1) to power the whole board.  
**Important:** power supply must be connected to the gateway shield USB port and not with the Nucleo USB port.  
On the Nucleo board, green LED LD6 (PWR) and LD4 (COM) light up. On the gateway shield, the green LED lights up.  
*Note: a USB wall adapter/charger is required to power the gateway.*
5. To view the gateway MAC address, channel frequency and status, connect the NUCLEO-F746ZG board with a personal computer by means of a USB Type-A to Micro-B cable through USB connector CN1. View the parameters using a terminal emulation software such as Tera Term.
6. Allow the personal computer to enumerate and install the USB drivers.  
*Take note of the Virtual COM port number assigned to the board.*
7. Open a terminal emulation software such as Tera Term and configure it with the following settings:
  - Port: (Virtual COM port number assigned to the board from step 6)
  - Baud rate: 115200
  - Data: 8 bit
  - Parity: none
  - Stop: 1 bit

- Press the reset button B2 (black button) to view the gateway MAC address, channel frequency and status. These parameters are further used to register the gateway to the network server (refer to [Section 7 Network server setup](#)). The USB cable (Virtual COM) can then be removed when the gateway is registered.

**Figure 25. Gateway parameter settings**

```

COM23 - Tera Term VT
File Edit Setup Control Window Help

-----
Powered by RisingHF & STMicroelectronics
-----
VERSION: 2.1.7, Nov 6 2018
LOG: OFF
AT ECHO: ON
BAUDRATE: 115200bps
MACADDR: 08:00:27:FF:FF:05:2733
ETHERNET: DHCP
DNS1: 114.114.114.114
DNS2: 8.8.8.8
NTP SERVER: 1.ubuntu.pool.ntp.org
EUI PADDING: <3, FF>, <4, FF>
GATEWAY ID: 080027FF052733
LORAWAN: Public
LORAWAN SERVER: eu1.loriot.io
UPLINK UDP PORT: 1780
DOWNLINK UDP PORT: 1780
CHANNEL0: 867100000, A, SF7/SF12, BW125KHz <LORA_MULTI_SF>
CHANNEL1: 867300000, A, SF7/SF12, BW125KHz <LORA_MULTI_SF>
CHANNEL2: 867500000, A, SF7/SF12, BW125KHz <LORA_MULTI_SF>
CHANNEL3: 867700000, A, SF7/SF12, BW125KHz <LORA_MULTI_SF>
CHANNEL4: 867900000, A, SF7/SF12, BW125KHz <LORA_MULTI_SF>
CHANNEL5: 868100000, B, SF7/SF12, BW125KHz <LORA_MULTI_SF>
CHANNEL6: 868300000, B, SF7/SF12, BW125KHz <LORA_MULTI_SF>
CHANNEL7: 868500000, B, SF7/SF12, BW125KHz <LORA_MULTI_SF>
CHANNEL8: 868300000, B, SF7, BW250KHz <LORA_STANDARD>
CHANNEL9: 868800000, B, 50Kbps <FSK>
-----
Concentrator starting...
Concentrator Radio A type SX1257
Concentrator Radio B type SX1257
Concentrator started (2926ms)
ST LoRa GW U2
Ethernet starting...
Ethernet started...
DHCP IP: 192.168.109.6
Downlink UDP Connected
Uplink UDP Connected
    
```

### P-NUCLEO-LRWAN2

The default setting of the LRWAN\_GS\_HF1 gateway is set to the EU868 frequency band and Loriot EU1 server.

### P-NUCLEO-LRWAN3

The default setting of the LRWAN\_GS\_LF1 gateway is set to the CN470Prequel frequency band and Loriot CN1 server.

## 6.2 Configuring the gateway to use a different frequency band

The *ST Nucleo LoRa GW* user guide from RisingHF ([\[3\]](#)) details the reconfiguration of the gateway using AT commands.

To change the frequency channels, use the `AT+CH` command. Reset the board for the new settings to take effect. At startup, firmware checks for the compatibility of the frequency band setting versus RF hardware. It displays a warning if the setting is not compatible with the hardware.

Set the packet forwarder channels as follows:

- Format:**  
`AT+CH=0~7,freq,radio // Set multi SF LoRa channel`  
`AT+CH=8,freq,radio,sf,bw // Set standard LoRa channel`  
`AT+CH=9,freq,radio // Set FSK channel`  
`AT+CH=0~9,0 // Turn off a channel`  
`AT+CH=0~9,OFF // Turn off a channel`  
`AT+CH=band // Set to predefined channel plan`
- Return:**  
`+CH: 0~7, freq, radio, SF7/SF12, BW125KHz (LORA_MULTI_SF)`  
`+CH: 8, freq, radio, SFx, BWxxxKHz (LORA_STANDARD)`  
`+CH: 9, freq, radio, 50Kbps (FSK)`

Refer to [3] for more details.

Predefined channels are available for quick setting of the frequency plan. Use the `AT+CH=band` command to use the predefined channels. The available bands are EU868, US915, EU433, CN780, AU915, AS923, KR920, CN470, CN470 prequel, and IN866. Table 6 shows the corresponding frequencies in MHz.

**Table 6. Predefined frequency channel plans**

CH	EU868	US915	EU433	CN780	AU915	AS923	KR920	CN470	CN470 Prequel	IN866
0	867.1	902.3	433.175	779.5	915.2	923.2	922.1	470.3	471.5	865.0625
1	867.3	902.5	433.375	779.7	915.4	923.4	922.3	470.5	471.7	865.2625
2	867.5	902.7	433.575	779.9	915.6	923.6	922.5	470.7	471.9	865.4625
3	867.7	902.9	433.775	780.1	915.8	923.8	922.7	470.9	472.1	865.6625
4	867.9	903.1	433.975	780.3	916.0	924.0	922.9	471.1	472.3	865.985
5	868.1	903.3	434.175	780.5	916.2	924.2	923.1	471.3	472.5	866.185
6	868.3	903.5	434.375	780.7	916.4	924.4	923.3	471.5	472.7	866.385
7	868.5	903.7	434.575	780.9	916.6	924.6	923.5	471.7	472.9	866.585
8	868.3 BW250 SF7	903.0 BW500 SF8	OFF	OFF	915.9 BW500 SF8	OFF	OFF	OFF	OFF	OFF
9	868.8 FSK 50 Kbps	OFF	OFF	OFF	OFF	OFF	OFF	OFF	OFF	OFF

For instance, to set the EU868 band plan, send AT command `AT+CH=EU868`.

```

AT+CH=EU868
AT+CH=0,867.1,A
AT+CH=1,867.3,A
AT+CH=2,867.5,A
AT+CH=3,867.7,A
AT+CH=4,867.9,B
AT+CH=5,868.1,B
AT+CH=6,868.3,B
AT+CH=7,868.5,B
AT+CH=8,868.3,B,7,250
AT+CH=9,868.8
    
```



For instance, to set the CN470Prequel band plan, send AT command `AT+CH=CN470PREQUEL`.

```
AT+CH=CN470PREQUEL
AT+CH=0,471.5,A
AT+CH=1,471.7,A
AT+CH=2,472.9,A
AT+CH=3,472.1,A
AT+CH=4,472.3,B
AT+CH=5,472.5,B
AT+CH=6,472.7,B
AT+CH=7,472.9,B
AT+CH=8,OFF
AT+CH=9,OFF
```

Reset the board for the new setting to take effect or use the `AT+RESET` command. The new frequency channels are displayed after reset. Use `AT+SYS` to view the configuration again.

Display for the P-NUCLEO-LRWAN2:

```

VERSION: 2.1.7, Nov 6 2018
LOG: OFF
AT ECHO: ON
BAUDRATE: 115200bps
MACADDR: 08:00:27:0C:23:38
ETHERNET: DHCP
DNS1: 114.114.114.114
DNS2: 8.8.8.8
NTP SERVER: 1.ubuntu.pool.ntp.org
EUI PADDING: {3, FF}, {4, FF}
GATEWAY ID: 080027FFFF0C2338
LORAWAN: Public
LORAWAN SERVER: eu1.loriot.io
UPLINK UDP PORT: 1780
DOWNLINK UDP PORT: 1780
CHANNEL0: 867100000, A, SF7/SF12, BW125KHz (LORA_MULTI_SF)
CHANNEL1: 867300000, A, SF7/SF12, BW125KHz (LORA_MULTI_SF)
CHANNEL2: 867500000, A, SF7/SF12, BW125KHz (LORA_MULTI_SF)
CHANNEL3: 867700000, A, SF7/SF12, BW125KHz (LORA_MULTI_SF)
CHANNEL4: 867900000, A, SF7/SF12, BW125KHz (LORA_MULTI_SF)
CHANNEL5: 868100000, B, SF7/SF12, BW125KHz (LORA_MULTI_SF)
CHANNEL6: 868300000, B, SF7/SF12, BW125KHz (LORA_MULTI_SF)
CHANNEL7: 868500000, B, SF7/SF12, BW125KHz (LORA_MULTI_SF)
CHANNEL8: 868300000, B, SF7, BW250KHz (LORA_STANDARD)
CHANNEL9: 868800000, B, 50Kbps (FSK)

```

Display for the P-NUCLEO-LRWAN3:

```

VERSION: 2.1.7, Nov 6 2018
LOG: OFF
AT ECHO: ON
BAUDRATE: 115200bps
MACADDR: xx:xx:xx:xx:xx:xx
ETHERNET: DHCP
DNS1: 114.114.114.114
DNS2: 8.8.8.8
NTP SERVER: 1.ubuntu.pool.ntp.org
EUI PADDING: {3, FF}, {4, FF}
GATEWAY ID: XXXXXXXXXXXXXXXXX
LORAWAN: Public
LORAWAN SERVER: cn1.loriot.io
UPLINK UDP PORT: 1780
DOWNLINK UDP PORT: 1780
CHANNEL0: 471500000, A, SF7/SF12, BW125KHz (LORA_MULTI_SF)
CHANNEL1: 471700000, A, SF7/SF12, BW125KHz (LORA_MULTI_SF)
CHANNEL2: 471900000, A, SF7/SF12, BW125KHz (LORA_MULTI_SF)
CHANNEL3: 472100000, A, SF7/SF12, BW125KHz (LORA_MULTI_SF)
CHANNEL4: 472300000, A, SF7/SF12, BW125KHz (LORA_MULTI_SF)
CHANNEL5: 472500000, B, SF7/SF12, BW125KHz (LORA_MULTI_SF)
CHANNEL6: 472700000, B, SF7/SF12, BW125KHz (LORA_MULTI_SF)
CHANNEL7: 472900000, B, SF7/SF12, BW125KHz (LORA_MULTI_SF)
CHANNEL8: OFF (LORA_STANDARD)
CHANNEL9: OFF (FSK)

```

### 6.3

## Changing the LoRaWAN® server, MAC address, and gateway EUI

By default, the gateway is configured to forward packets to Lorient network server. It is possible to use other servers that support the Semtech packet forwarder protocol. Use the following commands to change the settings:

- **AT+PKTFWD**  
Changes the packet forwarder server address and port. Refer to [3] for some of the available server addresses and uplink/downlink ports.  
AT+PKTFWD=address,port\_up,[port\_down]
  - **Example for Lorient AP1 server – Singapore:**  
AT+PKTFWD=apl.loriot.io,1780,1780  
+PKTFWD: apl.loriot.io, 1780, 1780
- **AT+MAC**  
Changes the MAC address if needed.  
AT+MAC=mac\_address
  - **Example:**  
AT+MAC=001122334455  
+MAC: 00:11:22:33:44:55
- **AT+MEUI**  
Sets the gateway EUI by adding paddings at specific positions of the Ethernet MAC address.  
AT+EUI=pos0,val0\_hex,pos1,val1\_hex
  - **Example:**  
AT+MAC  
+MAC: 00:11:22:33:44:55  
AT+EUI=3,FF,4,FF  
+EUI: 0, FF, 1, FE, 001122FFFF334455  
AT+RESET  
The gateway ID becomes 001122FFFF334455.

## 7 Network server setup

This section describes how to register the sensor device and gateway to the network server. The following network server providers are supported:

- Loriot
- The Things Network

### 7.1 Loriot network server setup

Go to the Loriot website at [www.loriot.io/](http://www.loriot.io/) and create an account on the preferred Loriot server, such as *EU1 – Frankfurt, Germany*, or *AP1 – Singapore*. Whichever Loriot server is used, the gateway needs to be configured to forward packets to the correct server address. Refer to [Section 6.3 Changing the LoRaWAN server, MAC address, and gateway EUI](#) on how to change the server address. The Loriot free account allows the registration of a limited number of devices and gateway with limited features for evaluation purpose. Refer to the Loriot website for more details about their offer.

The default network server setting for the P-NUCLEO-LRWAN2 gateway is: *eu1.loriot.io*. The corresponding Loriot network server that the user needs to create an account from must be *EU1 – Frankfurt, Germany*.

The default network server setting for the P-NUCLEO-LRWAN3 gateway is: *cn1.loriot.io*. The corresponding Loriot network server that the user needs to create an account from must be *CN1 – Shenzhen, China*.

If the nearest server is desired, the gateway LoRaWAN® server setting need to be changed accordingly to the new server address and port.

Both the LoRa® sensor device and gateway need to be registered to the Loriot network server. Log in to start registering the sensor device and gateway.

Figure 26. Loriot dashboard

The screenshot shows the Loriot dashboard for a professional account. The top navigation bar includes the Loriot logo, a menu icon, and user information: 'Professional Account', 'Singapore', and 'v.4.0.33'. The left sidebar contains navigation links: Logout, Dashboard, Applications (1), Networks (1), Join Servers, Documentation, FAQ & Help, Account, and Support.

The main dashboard area is titled 'Dashboard' and contains several sections:

- tier PROFESSIONAL ACCOUNT**: A welcome message stating 'Welcome to LORIIOT.io Professional Account!' and 'Your Virtual Private LoRaWAN is ready for use with your LoRa applications. Your account is now pre-configured with given number of gateways, applications, and per-application device capacity, based on your contract with LORIIOT.'
- PROFESSIONAL ACCOUNT features**: A list of features:
  - ✓ Custom number of gateways
  - ✓ Custom number of devices
  - ✓ Technical support per contract
- News**: A list of recent updates:
  - Dec 5, 2018, 12:00:00 AM: LORIIOT Network Server 4.0 has been released! Check our [release note](#) for more details.
  - Jun 15, 2018, 12:00:00 AM: LORIIOT Network Server 3.3 has been released! Check our [release note](#) for more details.
  - Mar 17, 2018, 12:00:00 AM: **IMPORTANT** Planned maintenance on Monday 19/03/2018 from 18:00 to 19:00 UTC to mitigate Meltdown and Spectre vulnerabilities. A temporary service interruption of approx. 15 minutes is expected.
  - Jul 10, 2017, 7:00:00 PM: We have a **fresh new user interface** ready for you. You will need to login separately into this interface, but can use both the current and the new in parallel. The old user interface will be sunset by October 2017. The [release notes](#) for the last update are now also available.
- Network Gateways**: A section with a '+ Register a new gateway' button. Below it is a table with columns: Location, Model, MAC, Version, Last Data. The table is currently empty with the message: 'No gateways registered. Start by [registering your gateway](#).'
- Applications**: A section with a '+ Add a new application' button. Below it is a table with columns: Name, AppID, Devices. The table contains one entry:
 

Name	AppID	Devices
ST_workshop	...	1

#### 7.1.1 Gateway registration to the Loriot network server

Follow the procedure below to register the gateway to the Loriot server:

1. Click on **[Register new gateway]**

2. Choose the base platform [**Packet Forwarder STM**]

Figure 27. ST gateway platform



3. Fill in the MAC address of the gateway. Refer to [Figure 25](#) for this information
4. Fill in the gateway location
5. Click [**Register Packet Forwarder STM gateway**]
6. From the Loriot dashboard, select the added gateway to view its detailed information
7. Edit the channel plan parameter and select the desired region frequency. The P-NUCLEO-LRWAN2 gateway default region frequency is *EU868\_Semtech*. The P-NUCLEO-LRWAN3 gateway default region frequency is *CN470*
8. The gateway status is updated after a few seconds

### 7.1.2 Device registration to Loriot network server

The device parameters are needed to enroll the device, depending on the join-mode setting of the device. Follow the procedure below to enroll the sensor device:

1. Go to [**Loriot Dashboard**] > [**Application**] > [**SampleApp**] > [**Enroll Device**]
2. Select the correct enrollment process of the device. The default enrollment is *OTAA*.
3. Fill in all necessary information. Refer to the credentials on the device sticker: *DevEUI*, *AppEUI* and *AppKey*
4. Click [**Enroll**]
5. Once enrolled, the device is visible in the device list in menu [**Devices**]
6. Reset the device to allow the device to join the network especially for OTAA devices.

- Go to the device details by clicking on the link corresponding to the recently-enrolled device. If the device has successfully joined the network, the *Last data (10 latest records)* sent by the device is visible. Note that the page may need to be refreshed to display the latest message entries.

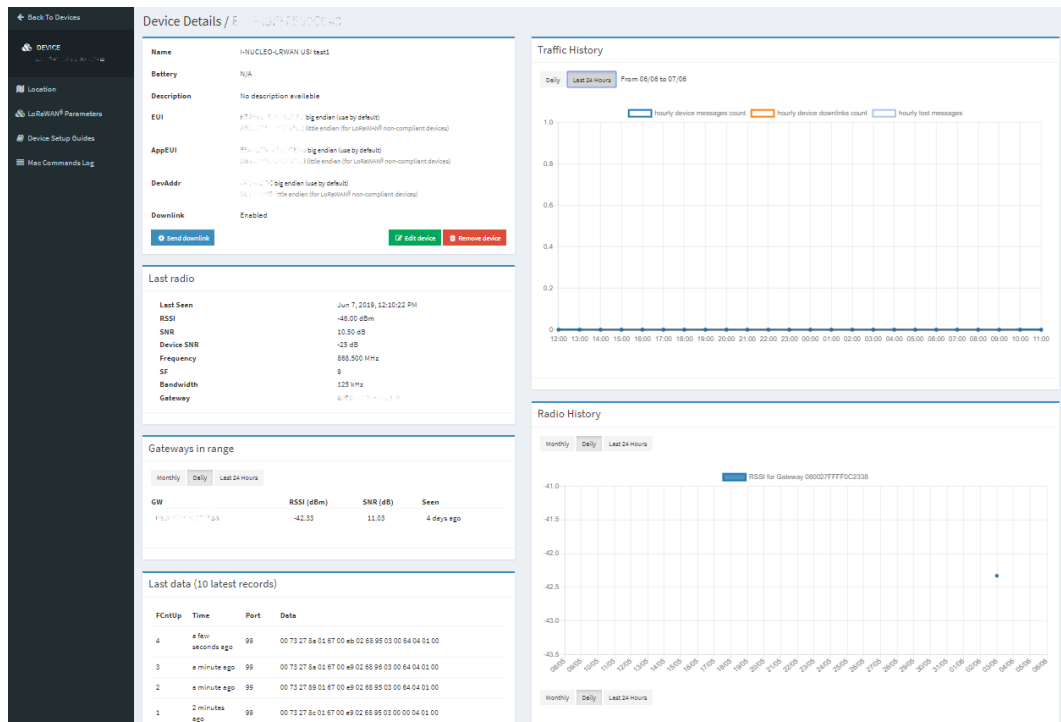
**Figure 28. Loriot registered device details**

### 7.1.3 Loriot default application output

A number of application APIs are available in [Loriot Dashboard]>[Application]>[SampleApp]>[Output]. Click on [Add new output] and select [WebSocket (by Loriot)].

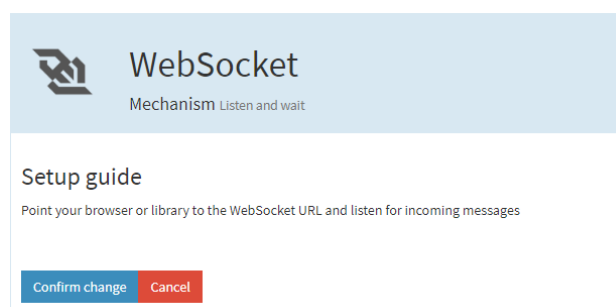
**Figure 29. WebSocket API from Loriot**

To view the packets received by the network, go to [Loriot Dashboard]>[Application]>[SampleApp]>[Websockets Applications] and click on the [WebSocket sample by LORIoT] sample application.





### 7.2.1 Gateway registration to The Things Network server

Follow the procedure below to register the gateway to The Things Network server:

1. Configure the gateway to send data to the closest router address. The list of routers is available from The Things Network website at [www.thethingsnetwork.org/docs/gateways/packet-forwarder/semtech-udp.html](http://www.thethingsnetwork.org/docs/gateways/packet-forwarder/semtech-udp.html).

A gateway configuration example is: `router.eu.thethings.network`.

Use the following AT command to configure the gateway packet forwarder to connect to The Things Network on UDP port 1700:

```
AT+PKTFWD=router.eu.thethings.network,1700,1700
```

2. In **[The Things Network Console Console]**, click on **[Gateways]>[Register Gateway]**.
3. Provide the necessary gateway information after checking the **[I'm using the legacy packet forwarder]** checkbox:
  - Gateway EUI: (taken from the gateway ID information. Refer to [Section 6](#) )
  - Description
  - Frequency plan: *Europe 868MHz*
  - Gateway location (click on the map)
  - Antenna placement: *Indoor*
4. Click on **[Register]**

**Figure 32. The Things Network registered gateway overview**

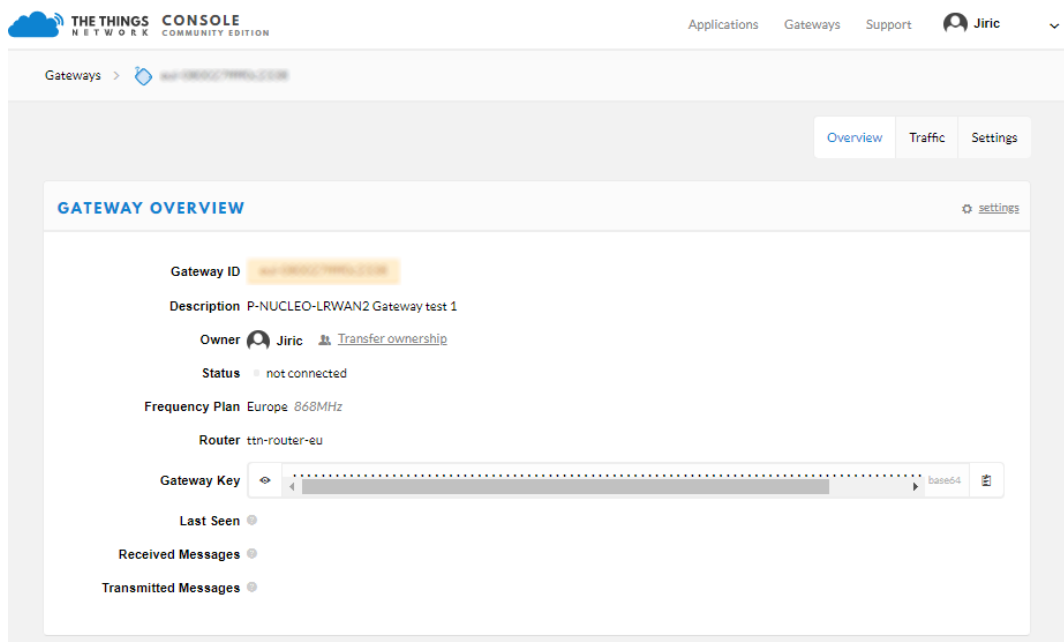

### 7.2.2 Device registration to The Things Network server

Follow the procedure below to enroll the sensor device:

1. From the **[Console]**, click on **[Applications]** and **[add application]** to create a device application for device registration.
2. Provide the necessary information:
  - Application ID: choose a unique ID or name made of lower-case, alphanumeric characters and nonconsecutive “-” and “\_”
  - Application description
  - Handler registration. For example: *example ttn-handler-eu*
3. Click on **[Add application]**.

- The AppEUI of the device needs to be added to the application. From the *Application Overview*, click on **[manage euis]**. Ignore or remove the existing EUI auto generated by the server.

Figure 33. The Things Network application overview

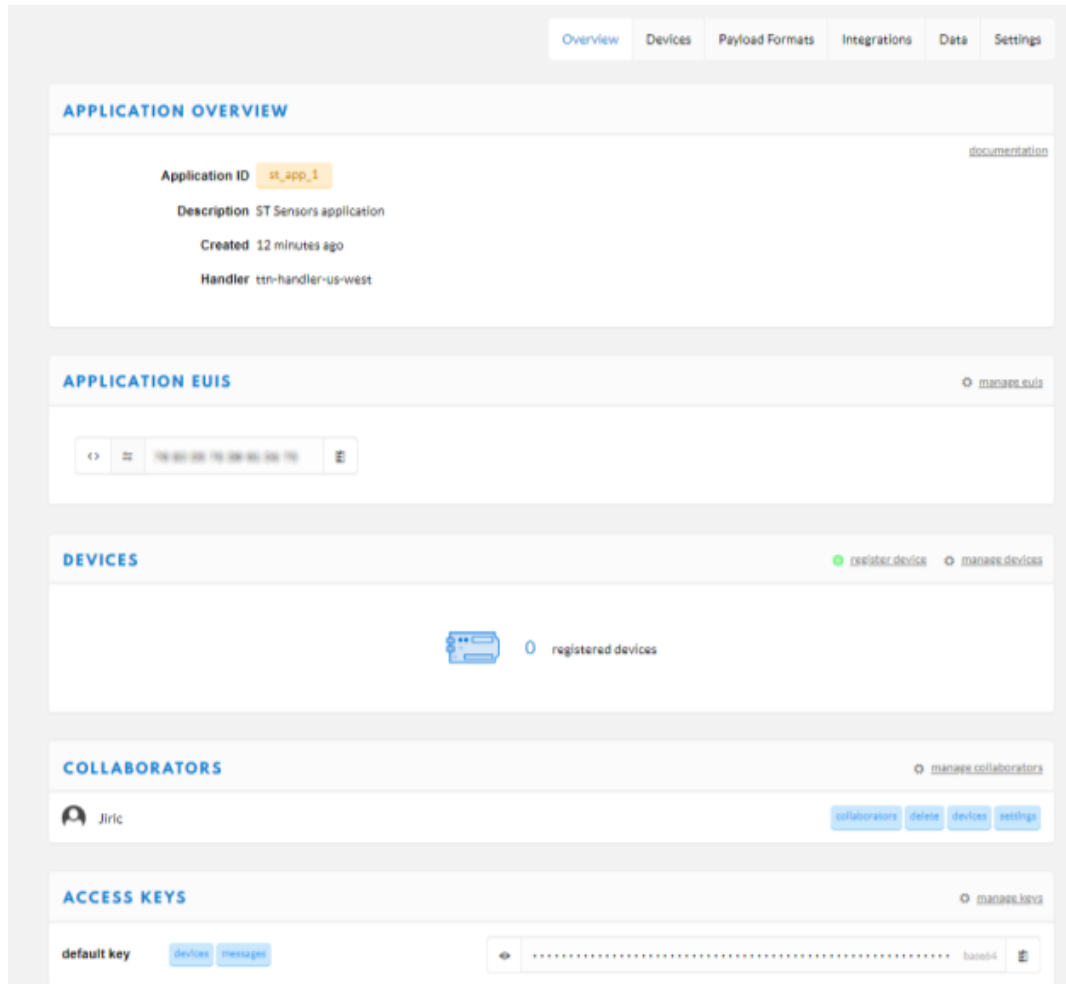

- Click on **[add EUI]** and then on the **[customize]** icon to edit the field.
- Enter the AppEUI of the device indicated in the device credentials sticker and then click on **[Add EUI]**. The added AppEUI is used later when registering the device.
- Select the *Devices* tab and then click on **[register device]**.
- Provide the necessary device information:
  - Device ID: choose a unique ID or name made of lower-case, alphanumeric characters and nonconsecutive “-” and “\_”
  - Device EUI: click on the **[customize]** icon and enter the DevEUI of the device (refer to the device credentials sticker)
  - App Key: click on the **[customize]** icon and enter the AppKey of the device (refer to the device credentials sticker)
  - App EUI: select the AppEUI of the device added at step 6
- Click on **[Register]** to complete the registration.

- The device overview shows the activation method (ensure it is set to OTAA), credentials, and status of the last packets received from the device.

**Figure 34. The Things Network registered device overview**

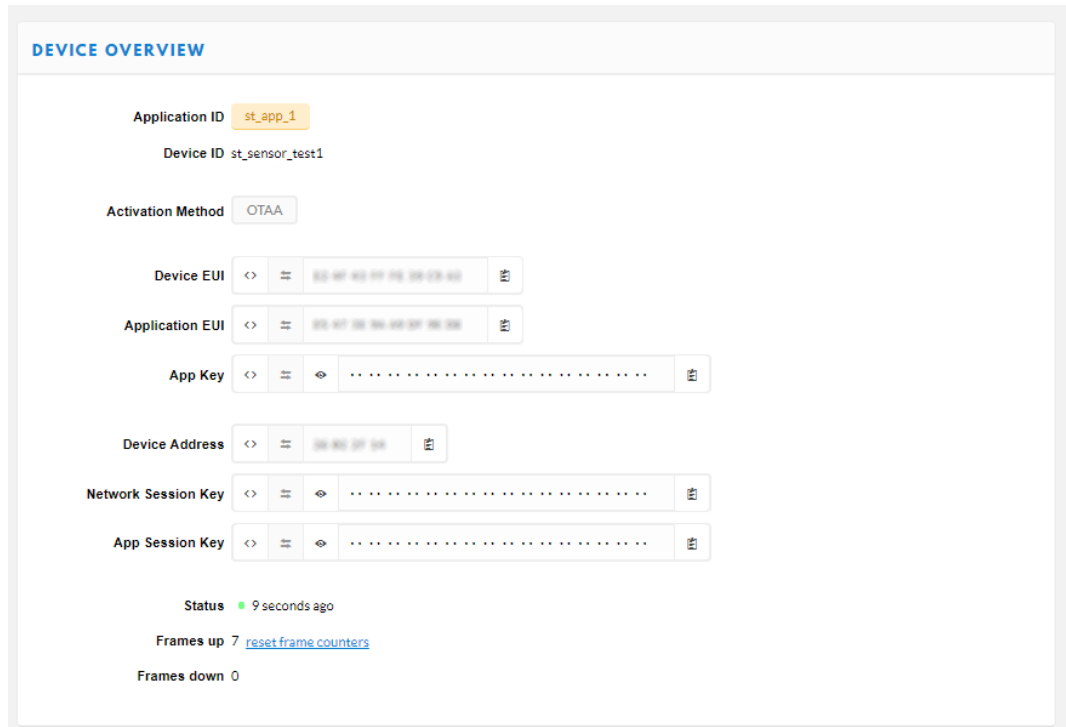

- Select the *Data* tab to view the packets received. The data can also be viewed from the *Application Data* view where it displays the data received from all registered devices in the application.

**Figure 35. The Things Network received data**

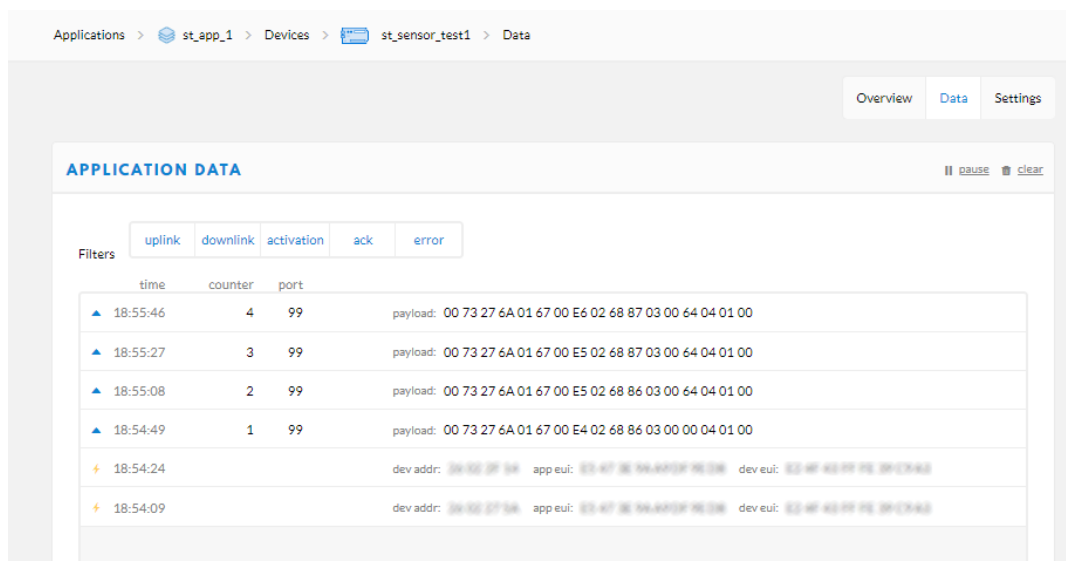

### 7.2.3 Setup the myDevices Cayenne integration in The Things Network

The network server can also be configured to forward the data to a third-party application server like myDevices Cayenne:

- In the *Application* view, click on **[Integrations]** and then **[add integrations]**

2. Select **[myDevices]** from the list of supported integrations
3. Think of a name for the *Process ID*
4. Select *default key* for the **[Access Key]**
5. Click on **[Add integration]**

Refer to [Section 8](#) to setup the myDevices Cayenne dashboard.

## 8 Application server setup

This section describes how to register the sensor device to a LoRa<sup>®</sup> application server. The following application server providers are supported:

- myDevices Cayenne

### 8.1 myDevices Cayenne application setup

Go to myDevices web site at <https://mydevices.com/> and create a free myDevices Cayenne account. The free account allows users to register LoRa<sup>®</sup> sensor devices connected to different LoRaWAN<sup>®</sup> network servers and view the sensor data on the dashboard. The widgets are customizable and trigger alerts can be set.

More details about the myDevices Cayenne dashboard is available from the <https://mydevices.com/cayenne/docs> web page.

Figure 36. Cayenne IoT project

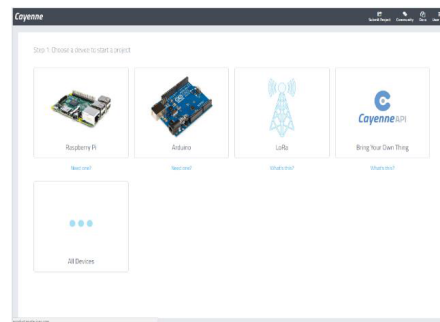

#### 8.1.1 Add a LoRa<sup>®</sup> device

1. Choose LoRa<sup>®</sup> from the list of IoT projects
2. From the LoRa<sup>®</sup> category, choose the network server used from the list of supported LoRaWAN<sup>®</sup> network servers, such as Lorient, The Things Network, or Actility ThingPark



- Select STM32 P-NUCLEO-LRWAN2 from the list of supported LoRa® devices

**Figure 37. Selecting a LoRa® device**

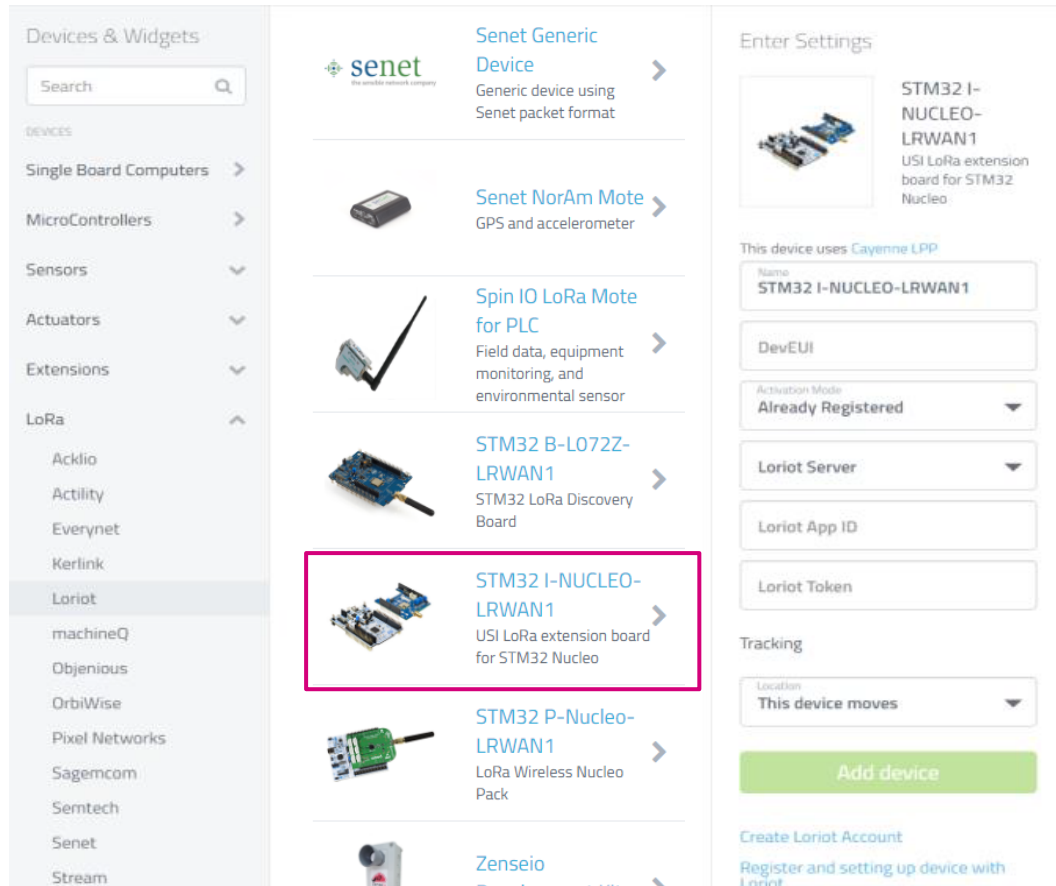

4. Enter the device settings, then add the device
  - For Lorient:
    - a. Name
    - b. DevEUI  
(refer to [**Lorient Dashboard**]>[**Application**]>[**SampleApp**]>[**Devices**]. Remove “-” or “:”)
    - c. Lorient server  
(the server used at Lorient account creation: *eu1.loriot.io*)
    - d. Lorient AppID  
(refer to [**Lorient Dashboard**]>[**Application**]>[**SampleApp**]: *Application ID*)
    - e. Lorient security token  
(refer to [**Lorient Dashboard**]>[**Application**]>[**SampleApp**]>[**Access Token**]: *Authentication Tokens*)
    - f. Tracking
      - i. This device moves (if the device sends packets with GPS coordinates)
      - ii. This device does not move (input fixed address)
  - For The Things Network (TTN):
    - a. Name
    - b. DevEUI  
(refer to [**TTN Dashboard**]>[**Application**]>[**appname**]>[**Devices**])
    - c. Tracking
      - i. This device moves (if the device sends packets with GPS coordinates)
      - ii. This device does not move (input fixed address)

### 8.1.2 Cayenne dashboard

The packets sent by the device are using the Cayenne low-power payload (LPP) format by default in the firmware code. As soon as packets are received in Cayenne, the widgets automatically appear in the dashboard depending on the data types used in the data payload. Widgets can be customized as per preference.

**Figure 38. myDevices Cayenne dashboard**



## 9 References

Table 7 lists the complementary references for using P-NUCLEO-LRWAN2 and P-NUCLEO-LRWAN3.

**Table 7. References**

ID	Description
[1]	Reference manual: <i>USI WM-SG-SM-42 AT Command.</i> Refer to Universal Scientific Industrial (USI®) web site at <a href="http://www.usiglobal.com">www.usiglobal.com</a> .
[2]	Reference manual: <i>[RHF-PS01709] LoRaWAN Class ABC AT Command Specification.</i> Refer to RisingHF web site at <a href="http://www.risinghf.com">www.risinghf.com</a> .
[3]	User guide: <i>ST Nucleo LoRa GW (RHF-UM01622).</i> Refer to RisingHF web site at <a href="http://www.risinghf.com">www.risinghf.com</a> .
[4]	User manual: <i>STM32 Nucleo-144 boards (UM1974).</i> Refer to STMicroelectronics web site at <a href="http://www.st.com">www.st.com</a> .
[5]	User manual: <i>STM32 Nucleo-64 boards (MB1136) (UM1724).</i> Refer to STMicroelectronics web site at <a href="http://www.st.com">www.st.com</a> .
[6]	User manual: <i>STM32 LoRa® Expansion Package for STM32Cube (UM2073).</i> Refer to STMicroelectronics web site at <a href="http://www.st.com">www.st.com</a> .
[7]	User manual: <i>STM32 ST-LINK Utility software description (UM0892).</i> Refer to STMicroelectronics web site at <a href="http://www.st.com">www.st.com</a> .
[8]	User manual: <i>STM32CubeProgrammer software description (UM2237).</i> Refer to STMicroelectronics web site at <a href="http://www.st.com">www.st.com</a> .

## Revision history

**Table 8. Document revision history**

Date	Version	Changes
25-Sep-2019	1	Initial release.

## Contents

<b>1</b>	<b>P-NUCLEO-LRWAN2 starter pack overview</b>	<b>2</b>
1.1	Sensor hardware overview	3
1.1.1	I-NUCLEO-LRWAN1 LoRa® HF band and sensor expansion board	5
1.2	Gateway hardware overview	6
1.2.1	Gateway expansion board	8
<b>2</b>	<b>P-NUCLEO-LRWAN3 starter pack overview</b>	<b>10</b>
2.1	P-NUCLEO-LRWAN3 starter pack known limitation	10
2.2	Sensor hardware overview	11
2.2.1	LRWAN_NS1 LoRa® LF band and sensor expansion board	13
2.3	Gateway hardware overview	14
2.3.1	Gateway expansion board	16
<b>3</b>	<b>P-NUCLEO-LRWAN2 / P-NUCLEO-LRWAN3 firmware overview</b>	<b>18</b>
3.1	I-CUBE-LRWAN LoRaWAN® STM32Cube Expansion Package	18
3.2	STM32F7 Nucleo LoRaWAN® gateway firmware	18
<b>4</b>	<b>I-NUCLEO-LRWAN1 sensor device setup and reconfiguration</b>	<b>21</b>
4.1	Sensor device setup	21
4.2	Extracting DevEUI and AppEUI from the LoRa® module	22
4.3	Reconfiguring the sensor device using the <i>AT_Master</i> project	23
<b>5</b>	<b>LRWAN_NS1 sensor device setup and reconfiguration</b>	<b>25</b>
5.1	Sensor device setup	25
5.2	Extracting DevEUI and AppEUI from the LoRa® module	26
5.3	Reconfiguring the sensor device using the <i>AT_Master</i> project	28
<b>6</b>	<b>Gateway setup and configuration</b>	<b>29</b>
6.1	Gateway setup	29
6.2	Configuring the gateway to use a different frequency band	30
6.3	Changing the LoRaWAN® server, MAC address, and gateway EUI	33
<b>7</b>	<b>Network server setup</b>	<b>34</b>
7.1	Loriot network server setup	34
7.1.1	Gateway registration to the Loriot network server	34

7.1.2	Device registration to Lorient network server .....	35
7.1.3	Lorient default application output .....	36
7.1.4	Setup the Cayenne data output in Lorient .....	37
7.2	The Things Network (TTN) server setup .....	37
7.2.1	Gateway registration to The Things Network server .....	37
7.2.2	Device registration to The Things Network server .....	38
7.2.3	Setup the myDevices Cayenne integration in The Things Network .....	40
<b>8</b>	<b>Application server setup .....</b>	<b>42</b>
8.1	myDevices Cayenne application setup .....	42
8.1.1	Add a LoRa® device .....	42
8.1.2	Cayenne dashboard .....	44
<b>9</b>	<b>References .....</b>	<b>45</b>
	<b>Revision history .....</b>	<b>46</b>
	<b>Contents .....</b>	<b>47</b>
	<b>List of tables .....</b>	<b>49</b>
	<b>List of figures .....</b>	<b>50</b>



## List of tables

<b>Table 1.</b>	P-NUCLEO-LRWAN2 gateway expansion board pins description . . . . .	8
<b>Table 2.</b>	P-NUCLEO-LRWAN3 gateway expansion board pins description . . . . .	16
<b>Table 3.</b>	AT command list . . . . .	19
<b>Table 4.</b>	Device activation and parameters (P-NUCLEO-LRWAN2) . . . . .	22
<b>Table 5.</b>	Device activation and parameters(P-NUCLEO-LRWAN3) . . . . .	27
<b>Table 6.</b>	Predefined frequency channel plans . . . . .	31
<b>Table 7.</b>	References . . . . .	45
<b>Table 8.</b>	Document revision history . . . . .	46

## List of figures

<b>Figure 1.</b>	P-NUCLEO-LRWAN2 and P-NUCLEO-LRWAN3 - LoRaWAN <sup>®</sup> sensors and gateways	1
<b>Figure 2.</b>	STM32 Nucleo LoRaWAN <sup>®</sup> development kit (P-NUCLEO-LRWAN2 starter pack)	2
<b>Figure 3.</b>	STM32 Nucleo LoRaWAN <sup>®</sup> sensor device (P-NUCLEO-LRWAN2)	4
<b>Figure 4.</b>	I-NUCLEO-LRWAN1 block diagram and connectors	5
<b>Figure 5.</b>	STM32 Nucleo LoRaWAN <sup>®</sup> gateway (P-NUCLEO-LRWAN2)	7
<b>Figure 6.</b>	Gateway expansion board (P-NUCLEO-LRWAN2)	8
<b>Figure 7.</b>	Hardware architectures of the P-NUCLEO-LRWAN2 gateway expansion board	9
<b>Figure 8.</b>	STM32 Nucleo LoRaWAN <sup>®</sup> development kit (P-NUCLEO-LRWAN3 starter pack)	10
<b>Figure 9.</b>	STM32 Nucleo LoRaWAN <sup>®</sup> sensor device (P-NUCLEO-LRWAN3)	12
<b>Figure 10.</b>	LRWAN_NS1 block diagram and connectors	13
<b>Figure 11.</b>	STM32 Nucleo LoRaWAN <sup>®</sup> gateway (P-NUCLEO-LRWAN3)	15
<b>Figure 12.</b>	Gateway expansion board (P-NUCLEO-LRWAN3)	16
<b>Figure 13.</b>	Hardware architecture of the P-NUCLEO-LRWAN3 gateway expansion board	17
<b>Figure 14.</b>	AT_Master in LoRaWAN <sup>®</sup> STM32Cube Expansion Package	18
<b>Figure 15.</b>	Programming the gateway using a binary file	20
<b>Figure 16.</b>	ST-LINK driver installation	21
<b>Figure 17.</b>	Antenna and personal computer connection	21
<b>Figure 18.</b>	USB enumerated instances	22
<b>Figure 19.</b>	I-NUCLEO-LRWAN1 expansion board serial port	23
<b>Figure 20.</b>	ST-LINK driver installation	25
<b>Figure 21.</b>	Antenna and personal computer connection	25
<b>Figure 22.</b>	USB enumerated instances	26
<b>Figure 23.</b>	Terminal emulation software settings	26
<b>Figure 24.</b>	LRWAN_NS1 expansion board serial port	27
<b>Figure 25.</b>	Gateway parameter settings	30
<b>Figure 26.</b>	Loriot dashboard	34
<b>Figure 27.</b>	ST gateway platform	35
<b>Figure 28.</b>	Loriot registered device details	36
<b>Figure 29.</b>	WebSocket API from Loriot	36
<b>Figure 30.</b>	WebSocket sample by LORIoT	37
<b>Figure 31.</b>	The Things Network Console	37
<b>Figure 32.</b>	The Things Network registered gateway overview	38
<b>Figure 33.</b>	The Things Network application overview	39
<b>Figure 34.</b>	The Things Network registered device overview	40
<b>Figure 35.</b>	The Things Network received data	40
<b>Figure 36.</b>	Cayenne IoT project	42
<b>Figure 37.</b>	Selecting a LoRa <sup>®</sup> device	43
<b>Figure 38.</b>	myDevices Cayenne dashboard	44

**IMPORTANT NOTICE – PLEASE READ CAREFULLY**

STMicroelectronics NV and its subsidiaries (“ST”) reserve the right to make changes, corrections, enhancements, modifications, and improvements to ST products and/or to this document at any time without notice. Purchasers should obtain the latest relevant information on ST products before placing orders. ST products are sold pursuant to ST’s terms and conditions of sale in place at the time of order acknowledgement.

Purchasers are solely responsible for the choice, selection, and use of ST products and ST assumes no liability for application assistance or the design of Purchasers’ products.

No license, express or implied, to any intellectual property right is granted by ST herein.

Resale of ST products with provisions different from the information set forth herein shall void any warranty granted by ST for such product.

ST and the ST logo are trademarks of ST. For additional information about ST trademarks, please refer to [www.st.com/trademarks](http://www.st.com/trademarks). All other product or service names are the property of their respective owners.

Information in this document supersedes and replaces information previously supplied in any prior versions of this document.

© 2019 STMicroelectronics – All rights reserved