

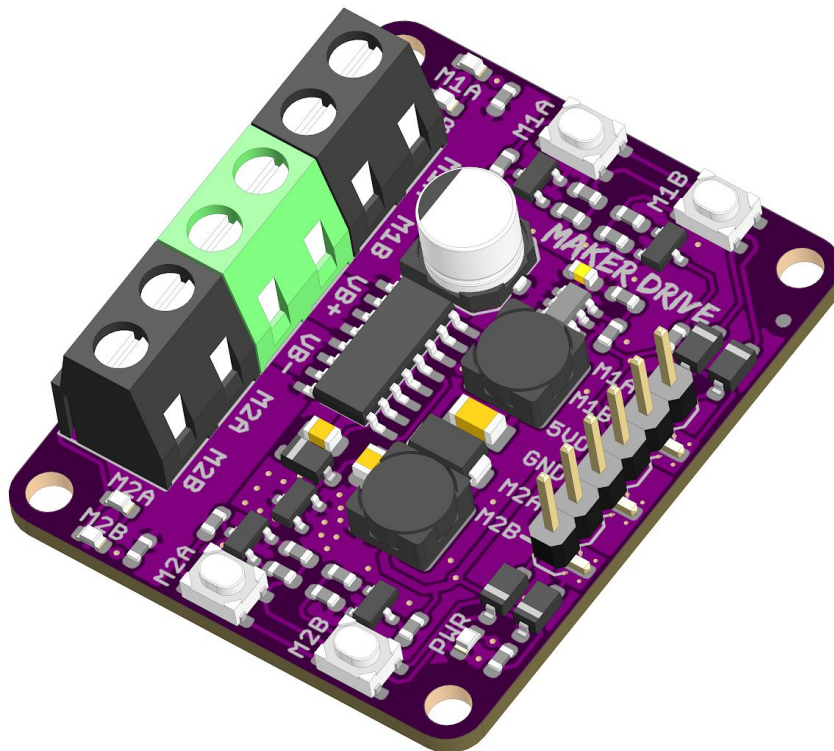

MAKER-DRIVE

Simplifying H-Bridge Motor Driver for Beginner



Datasheet

Rev 1.0
Feb 2019

Information in this publication regarding device applications and the like is intended through suggestion only and may be superseded by updates. It is your responsibility to ensure that your application meets with your specifications. No representation or warranty is given and no liability is assumed by Cytron Technologies Incorporated with respect to the accuracy or use of such information or infringement of patents or other intellectual property rights arising from such use or otherwise. Use of Cytron Technologies's products as critical components in life support system is not authorized except with express written approval by Cytron Technologies. No licenses are conveyed, implicitly or otherwise, under any intellectual property rights.

1. BOARD LAYOUT & FUNCTION

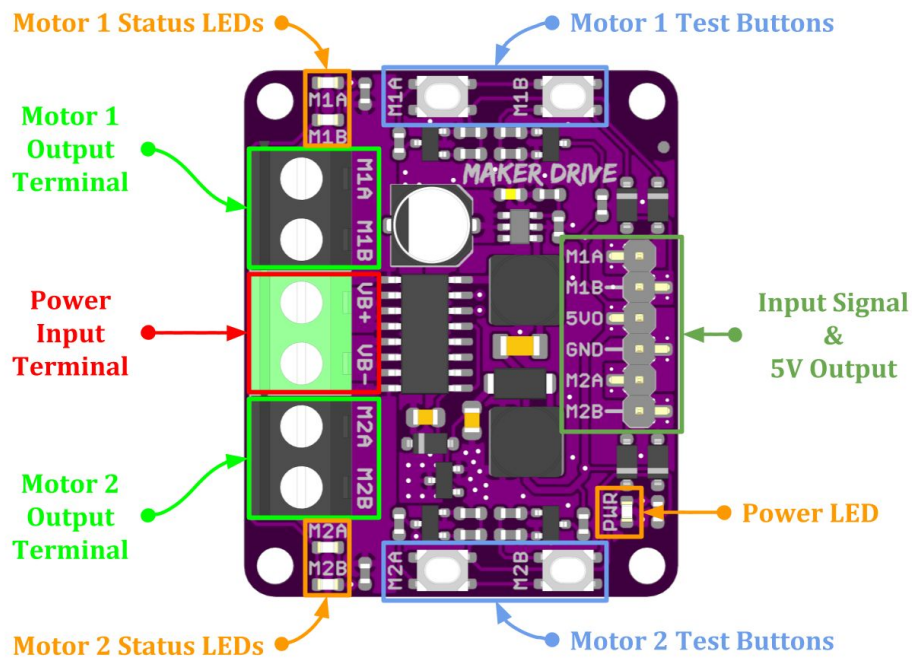

Figure 1: MAKER-DRIVE Board Functions

Function	Description
Power Input Terminal	Connect to battery. <ul style="list-style-type: none"> • VB+ : Positive • VB- : Negative
Motor Output Terminal	Connect to motor terminal. Motor direction depends on the polarity.
Power LED	Turn on when power up.
Motor Status LEDs	Turn on when the motor is running. <ul style="list-style-type: none"> • M1A / M2A : Forward* • M1B / M2B : Backward*
Test Buttons	Press to test the functionality of the motor driver. Motor will run at full speed. <ul style="list-style-type: none"> • M1A / M2A : Forward* • M1B / M2B : Backward*
Input Signal & 5V Output	Input signal from microcontroller to control the motor. +5V output can be used to power the microcontroller. <ul style="list-style-type: none"> • M1A : PWM Input A for motor 1. • M1B : PWM Input B for motor 1. • 5V0 : DC +5V Output (Maximum 200mA) • GND : Ground • M2A : PWM Input A for motor 2. • M2B : PWM Input B for motor 2.

Table 1: MAKER-DRIVE Board Functions

* Actual motor direction is depending on the motor connection.

Swapping the connection (MA & MB) will reverse the direction.

2. SPECIFICATIONS

No	Parameters	Min	Max	Unit	
1	Power Input Voltage	2.5	9.5	VD C	
2	Maximum Motor Current	Continuous	-	1	A
		Peak (< 5 seconds)	-	1.5	A
3	Logic Input Voltage (M1A, M1B, M2A, M2B)	Low Level	0	0.5	V
		High Level	1.7	6	V
4	PWM Frequency (Output frequency is same as input frequency)	DC	20	KHz	
5	DC +5V Output Maximum Current	-	200	mA	

Table 2: MAKER-DRIVE Absolute Maximum Ratings

3. DIMENSION

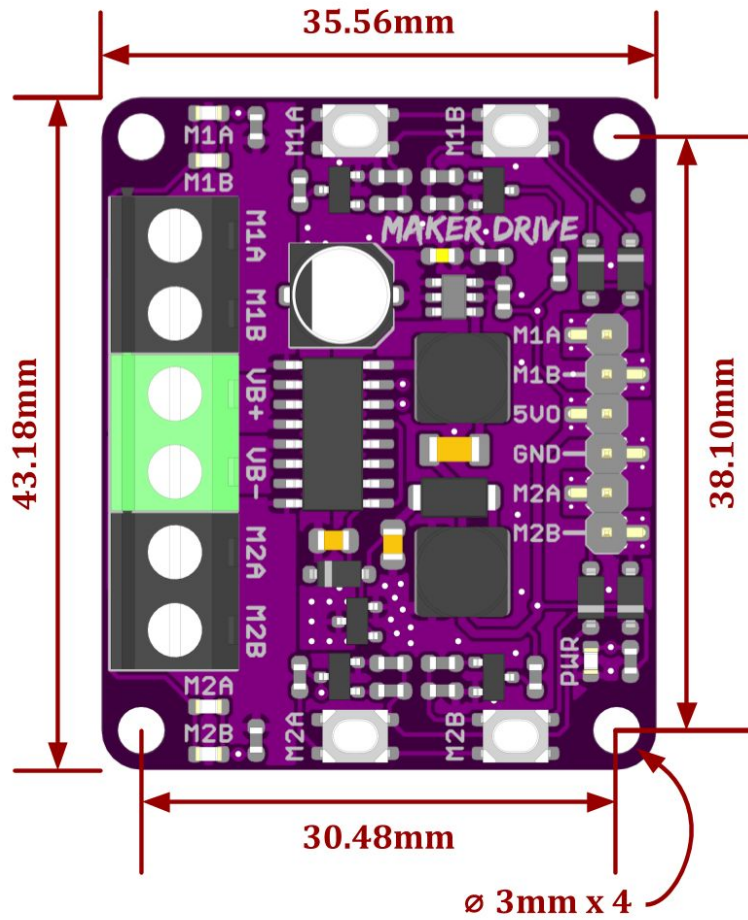

Figure 2: MAKER-DRIVE Dimension

4. INTERFACE

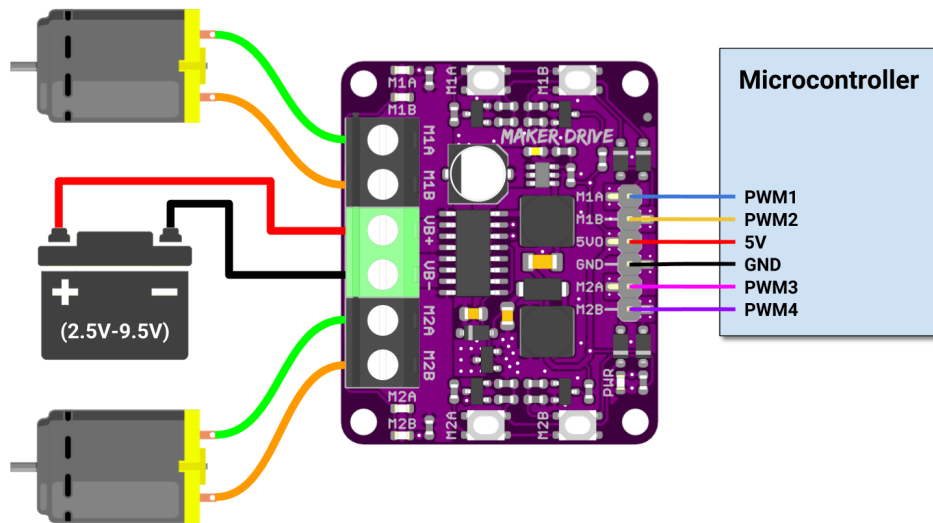

Figure 3: Connection Diagram for Brushed DC Motor

Input A (M1A / M2A)	Input B (M1B / M2B)	Output A (M1A / M2A)	Output B (M1B / M2B)	Motor
Low	Low	Low	Low	Brake
High	Low	High	Low	Forward*
Low	High	Low	High	Backward*
High	High	Hi-Z (Open)	Hi-Z (Open)	Coast

Table 3: Input Truth Table

* Actual motor direction is depending on the motor connection.
 Swapping the connection (MA & MB) will reverse the direction.

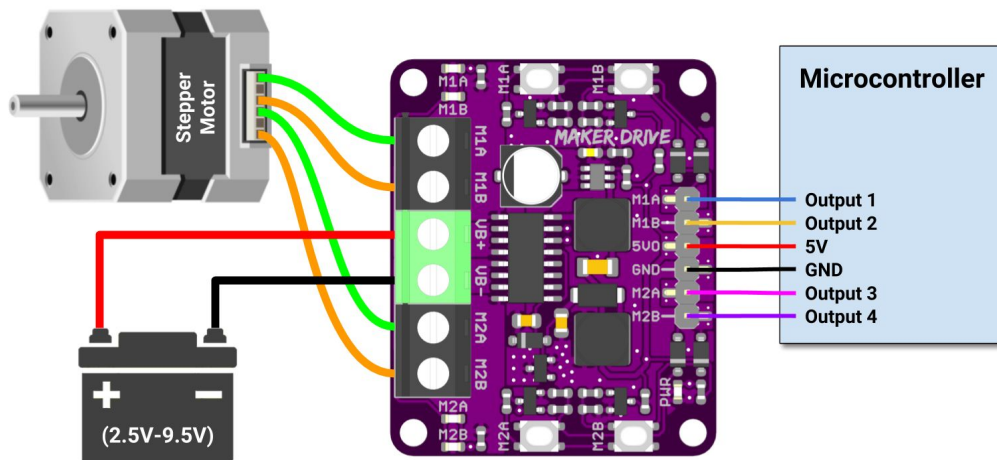

Figure 4: Connection Diagram for Stepper Motor

5. PROTECTION FEATURES

- **Power Input Reversed Polarity Protection**

Protect the motor driver from damage if the battery is connected in wrong polarity. This is a very common mistake done by a lot of makers even for the very experienced one.

- **Temperature Protection**

The motor driver H-Bridge IC has built-in over temperature protection. Output to the motor will be cut off when the IC internal temperature is over 150 degree Celsius. This protects the H-bridge from damage caused by overheating.

Prepared by:

Cytron Technologies Sdn Bhd

www.cytron.io

No. 1, Lorong Industri Impian 1,
Taman Industri Impian,
14000 Bukit Mertajam,
Penang, Malaysia.

Tel: +604 - 548 0668

Fax: +604 - 548 0669

Email:

support@cytron.io

sales@cytron.io