



ST7735S

**132RGB x 162dot 262K Color with Frame Memory
Single-Chip TFT Controller/Driver**

Datasheet

**Version 1.1
2011/11**

Sitronix Technology Corporation

Sitronix Technology Corp. reserves the right to change the contents in this document without prior notice.

LIST OF CONTENT

| | | |
|----------|--|-----------|
| 1 | GENERAL DESCRIPTION | 2 |
| 2 | FEATURES | 2 |
| 3 | PAD ARRANGEMENT | 4 |
| | 3.1 Output Bump Dimension | 4 |
| | 3.2 Input Bump Dimension | 5 |
| | 3.3 Alignment Mark Dimension | 6 |
| | 3.4 Chip Information | 7 |
| 4 | PAD CENTER COORDINATES | 8 |
| 5 | BLOCK DIAGRAM | 14 |
| 6 | PIN DESCRIPTION | 15 |
| | 6.1 Power Supply Pin | 15 |
| | 6.2 Interface Logic Pin | 15 |
| | 6.3 Mode Selection Pin | 17 |
| | 6.4 Driver Output pins | 18 |
| | 6.5 Test Pins | 19 |
| 7 | DRIVER ELECTRICAL CHARACTERISTICS | 20 |
| | 7.1 Absolute Operation Range | 20 |
| | 7.2 DC Characteristic | 21 |
| | 7.3 Power Consumption | 22 |
| 8 | Timing chart | 23 |
| | 8.1 Parallel Interface Characteristics: 18, 16, 9 or 8-bit Bus (8080 Series MCU Interface) 23 | |
| | 8.2 Parallel Interface Characteristics: 18, 16, 9 or 8-bit Bus (6800 Series MCU Interface) 25 | |
| | 8.3 Serial Interface Characteristics (3-line Serial) | 27 |
| | 8.4 Serial Interface Characteristics (4-line Serial) | 28 |
| 9 | Function Description | 29 |
| | 9.1 Interface Type Selection | 29 |
| | 9.2 8080-series MCU Parallel Interface (P68 = '0') | 30 |
| | 9.2.1 Write Cycle Sequence | 31 |
| | 9.2.2 Read Cycle Sequence | 32 |
| | 9.3 6800-series MCU Parallel Interface (P68 = '1') | 33 |
| | 9.3.1 Write Cycle Sequence | 34 |
| | 9.3.2 Read Cycle Sequence | 35 |
| | 9.4 Serial Interface | 36 |
| | 9.4.1 Command Write Mode | 36 |
| | 9.4.2 Read Functions | 38 |

| | |
|---|-----------|
| 9.4.3 3-line Serial Protocol | 38 |
| 9.4.4 4-line Serial Protocol | 39 |
| 9.5 Data Transfer Break and Recovery..... | 40 |
| 9.6 Data Transfer Pause..... | 42 |
| 9.6.1 Serial Interface Pause..... | 42 |
| 9.6.2 Parallel Interface Pause | 42 |
| 9.7 Data Transfer Modes | 43 |
| 9.7.1 Method 1 | 43 |
| 9.7.2 Method 2 | 43 |
| 9.8 Data Color Coding | 44 |
| 9.8.1 8-bit Parallel Interface (IM2, IM1, IM0= "100") | 44 |
| 9.8.2 8-bit Data Bus for 12-bit/Pixel (RGB 4-4-4-bit Input), 4K-Colors, 3AH= "03h" | 44 |
| 9.8.3 8-bit Data Bus for 16-bit/Pixel (RGB 5-6-5-bit Input), 65K-Colors, 3AH= "05h" | 45 |
| 9.8.4 8-bit Data Bus for 18-bit/Pixel (RGB 6-6-6-bit Input), 262K-Colors, 3AH= "06h" | 46 |
| 9.8.5 16-Bit Parallel Interface (IM2,IM1, IM0= "101")..... | 47 |
| 9.8.6 16-bit Data Bus for 12-bit/Pixel (RGB 4-4-4-bit Input), 4K-Colors, 3AH= "03h" | 47 |
| 9.8.7 16-bit Data Bus for 16-bit/Pixel (RGB 5-6-5-bit Input), 65K-Colors, 3AH= "05h" | 48 |
| 9.8.8 16-bit Data Bus for 18-bit/Pixel (RGB 6-6-6-bit Input), 262K-Colors, 3AH= "06h" | 49 |
| 9.8.9 9-Bit Parallel Interface (IM2, IM1, IM0="110")..... | 50 |
| 9.8.10 Write 9-bit Data for RGB 6-6-6-bit Input (262k-color) | 50 |
| 9.8.11 18-Bit Parallel Interface (IM2, IM1, IM0="111")..... | 51 |
| 9.8.12 18-bit Data Bus for 12-bit/Pixel (RGB 4-4-4-bit Input), 4K-Colors, 3AH="03h"..... | 51 |
| 9.8.13 18-bit Data Bus for 16-bit/Pixel (RGB 5-6-5-bit Input), 65K-Colors, 3AH="05h"..... | 52 |
| 9.8.14 18-bit Data Bus for 18-bit/Pixel (RGB 6-6-6-bit Input), 262K-Colors, 3AH="06h"..... | 53 |
| 9.8.15 3-line Serial Interface | 54 |
| 9.8.16 Write Data for 12-bit/Pixel (RGB 4-4-4-bit Input), 4K-Colors, 3AH="03h"..... | 54 |
| 9.8.17 Write Data for 16-bit/Pixel (RGB 5-6-5-bit Input), 65K-Colors, 3AH="05h"..... | 55 |
| 9.8.18 Write Data for 18-bit/Pixel (RGB 6-6-6-bit Input), 262K-Colors, 3AH="06h"..... | 56 |
| 9.8.19 4-line Serial Interface | 57 |
| 9.8.20 Write Data for 12-bit/Pixel (RGB 4-4-4-bit Input), 4K-Colors, 3AH="03h"..... | 57 |
| 9.8.21 Write Data for 16-bit/Pixel (RGB 5-6-5-bit Input), 65K-Colors, 3AH="05h"..... | 58 |
| 9.8.22 Write Data for 18-bit/Pixel (RGB 6-6-6-bit Input), 262K-Colors, 3AH="06h"..... | 58 |
| 9.9 Display Data RAM..... | 59 |
| 9.9.1 Configuration (GM[1:0] = "00") | 59 |
| 9.9.2 Memory to Display Address Mapping | 60 |
| 9.9.3 When using 128RGB x 160 resolution (GM[1:0] = "11", SMX=SMY=SRGB= '0') | 60 |
| 9.9.4 When using 132RGB x 132resolution (GM[1:0] = "01", SMX=SMY=SRGB= '0') | 61 |
| 9.9.5 When using 132RGB x 162 resolution (GM[1:0] = "00", SMX=SMY=SRGB= '0') | 62 |

9.9.6 Normal Display On or Partial Mode On..... 63

9.9.7 When using 128RGB x 160 resolution (GM[1:0] = “11”) 63

9.9.8 When using 128RGB x 160 resolution (GM[1:0] = “01”) 64

9.9.9 When using 132RGB x 162 resolution (GM[1:0] = “00”) 65

9.10 Address Counter66

9.11 Memory Data Write/ Read Direction67

9.11.1 When 128RGBx160 (GM= “11”) 67

9.11.2 When 132RGBx132 (GM= “01”) 67

9.11.3 When 132RGBx162 (GM= “00”) 68

9.11.4 Frame Data Write Direction According to the MADCTL Parameters (MV, MX and MY) 69

9.11.5 Scroll Address Circuit..... 70

9.11.6 Vertical Scroll Mode 70

9.11.7 Vertical Scroll Example 71

9.11.8 Case 1: TFA + VSA + BFA<162 71

9.11.9 Case 2: TFA + VSA + BFA=162 (Rolling Scrolling) 72

9.12 Tearing Effect Output Line73

9.12.1 Tearing Effect Line Modes 73

9.12.2 Tearing Effect Line Timings 74

9.12.3 Example 1: MPU Write is faster than panel read 75

9.12.4 Example 2: MPU Write is slower than panel read..... 76

9.13 Power ON/OFF Sequence77

9.13.1 Uncontrolled Power Off 78

9.14 Power Level Definition79

9.14.1 Power Level..... 79

9.14.2 Power Flow Chart..... 80

9.15 Reset Table81

9.15.1 Reset Table(Default Value, GM[1:0]=“11”, 128RGB x 160)..... 81

9.15.2 Reset Table (GM[1:0]= “01”, 132RGB x 132) 82

9.15.3 Reset Table (GM[1:0]= “00”, 132RGB x 162) 83

9.16 Module Input/Output Pins84

9.16.1 Output or Bi-directional (I/O) Pins 84

9.17 Reset Timing.....85

9.18 Color Depth Conversion Look Up Tables.....86

9.18.1 65536 Color to 262,144 Color 86

9.18.2 4096 Color to 262,144 Color 90

9.19 Sleep Out-Command and Self-Diagnostic Functions of the Display Module92

9.19.1 Register Loading Detection..... 92

9.19.2 Functionality Detection..... 93

| | |
|---|-----------|
| 9.19.3 Chip Attachment Detection (Optional) | 94 |
| 9.19.4 Display Glass Break Detection (Optional)..... | 95 |
| 10 COMMAND..... | 96 |
| 10.1 System Function Command List and Description | 96 |
| 10.1.1 NOP (00h) | 99 |
| 10.1.2 SWRESET (01h): Software Reset | 100 |
| 10.1.3 RDDID (04h): Read Display ID | 101 |
| 10.1.4 RDDST (09h): Read Display Status..... | 102 |
| 10.1.5 RDDPM (0Ah): Read Display Power Mode | 104 |
| 10.1.6 RDDMADCTL (0Bh): Read Display MADCTL | 105 |
| 10.1.7 RDDCOLMOD (0Ch): Read Display Pixel Format..... | 106 |
| 10.1.8 RDDIM (0Dh): Read Display Image Mode..... | 107 |
| 10.1.9 RDDSM (0Eh): Read Display Signal Mode..... | 108 |
| 10.1.10 RDDSDR (0Fh): Read Display Self-Diagnostic Result | 110 |
| 10.1.11 SLPIN (10h): Sleep In | 111 |
| 10.1.12 SLPOUT (11h): Sleep Out | 112 |
| 10.1.13 PTLON (12h): Partial Display Mode On..... | 113 |
| 10.1.14 NORON (13h): Normal Display Mode On | 114 |
| 10.1.15 INVOFF (20h): Display Inversion Off | 115 |
| 10.1.16 INVON (21h): Display Inversion On | 116 |
| 10.1.17 GAMSET (26h): Gamma Set | 117 |
| 10.1.18 DISPOFF (28h): Display Off..... | 118 |
| 10.1.19 DISPON (29h): Display On | 119 |
| 10.1.20 CASET (2Ah): Column Address Set | 120 |
| 10.1.21 RASET (2Bh): Row Address Set | 122 |
| 10.1.22 RAMWR (2Ch): Memory Write..... | 124 |
| 10.1.23 RGBSET (2Dh): Color Setting for 4K, 65K and 262K..... | 125 |
| 10.1.24 RAMRD (2Eh): Memory Read | 126 |
| 10.1.25 PTLAR (30h): Partial Area | 127 |
| 10.1.26 SCRLAR (33h): Scroll Area Set | 129 |
| 10.1.27 TEOFF (34h): Tearing Effect Line OFF | 131 |
| 10.1.28 TEON (35h): Tearing Effect Line ON | 132 |
| 10.1.29 MADCTL (36h): Memory Data Access Control | 134 |
| 10.1.30 VSCSAD: Vertical Scroll Start Address of RAM (37h)..... | 137 |
| 10.1.31 IDMOFF (38h): Idle Mode Off | 139 |
| 10.1.32 IDMON (39h): Idle Mode On | 140 |
| 10.1.33 COLMOD (3Ah): Interface Pixel Format | 142 |
| 10.1.34 RDID1 (DAh): Read ID1 Value..... | 143 |

| | |
|--|------------|
| 10.1.35 RDID2 (DBh): Read ID2 Value..... | 144 |
| 10.1.36 RDID3 (DCh): Read ID3 Value | 146 |
| 10.2 Panel Function Command List and Description | 147 |
| 10.2.1 FRMCTR1 (B1h): Frame Rate Control (In normal mode/ Full colors) | 151 |
| 10.2.2 FRMCTR2 (B2h): Frame Rate Control (In Idle mode/ 8-colors) | 152 |
| 10.2.3 FRMCTR3 (B3h): Frame Rate Control (In Partial mode/ full colors) | 153 |
| 10.2.4 INVCTR (B4h): Display Inversion Control..... | 154 |
| 10.2.5 PWCTR1 (C0h): Power Control 1 | 155 |
| 10.2.6 PWCTR2 (C1h): Power Control 2 | 157 |
| 10.2.7 PWCTR3 (C2h): Power Control 3 (in Normal mode/ Full colors)..... | 159 |
| 10.2.8 PWCTR4 (C3h): Power Control 4 (in Idle mode/ 8-colors)..... | 161 |
| 10.2.9 PWCTR5 (C4h): Power Control 5 (in Partial mode/ full-colors) | 163 |
| 10.2.10 VMCTR1 (C5h): VCOM Control 1 | 165 |
| 10.2.11 VMOFCTR (C7h): VCOM Offset Control | 167 |
| 10.2.12 WRID2 (D1h): Write ID2 Value | 169 |
| 10.2.13 WRID3 (D2h): Write ID3 Value | 170 |
| 10.2.14 NVFCTR1 (D9h): NVM Control Status..... | 171 |
| 10.2.15 NVFCTR2 (DEh): NVM Read Command..... | 172 |
| 10.2.16 NVFCTR3 (DFh): NVM Write Command | 173 |
| 10.2.17 GMCTRP1 (E0h): Gamma ('+'polarity) Correction Characteristics Setting | 174 |
| 10.2.18 GMCTRN1 (E1h): Gamma '-'polarity Correction Characteristics Setting | 176 |
| 10.2.19 GCV(FCh): Gate Pump Clock Frequency Variable | 178 |
| 11 Power Sturcture | 179 |
| 11.1 Driver IC Operating Voltage Specification..... | 179 |
| 11.2 Power Booster Circuit | 180 |
| 12 Gamma Structure..... | 181 |
| 12.1 Structure of Grayscale Amplifier | 181 |
| 12.2 Gamma Voltage Formula (Positive/ Negative Polarity) | 182 |
| 13 Example Connection with Panel Direction and Different Resolution | 184 |
| 13.1 Application of Connection with Panel Direction..... | 184 |
| 13.2 Application of Connection with Different Resolution..... | 186 |
| 13.3 Microprocessor Interface Applications | 189 |
| 13.3.1 8080-Series MCU Interface for 8-bit Data Bus (P68=0, IM2, IM1, IM0="100")..... | 189 |
| 13.3.2 8080-Series MCU Interface for 16-bit Data Bus (P68=0, IM2, IM1, IM0="101")..... | 189 |
| 13.3.3 8080-Series MCU Interface for 9-bit Data Bus (P68=0, IM2, IM1, IM0="110")..... | 189 |
| 13.3.4 8080-Series MCU Interface for 18-bit Data Bus (P68=0, IM2, IM1, IM0="111")..... | 190 |
| 13.3.5 6800-Series MCU Interface for 8-bit Data Bus (P68=1, IM2, IM1, IM0="100")..... | 190 |

| | |
|--|------------|
| 13.3.6 6800-Series MCU Interface for 16-bit Data Bus (P68=1, IM2, IM1, IM0="101")..... | 190 |
| 13.3.7 6800-Series MCU Interface for 9-bit Data Bus (P68=1, IM2, IM1, IM0="110")..... | 191 |
| 13.3.8 6800-Series MCU Interface for 18-bit Data Bus (P68=1, IM2, IM1, IM0="111")..... | 191 |
| 13.3.9 3-Line Serial MCU Interface (IM2, IM1, IM0="000", SPI4W=0)..... | 191 |
| 13.3.10 4-Line Serial MCU Interface (IM2, IM1, IM0="000", SPI4W=1)..... | 192 |
| 14 Revision History | 193 |

LIST OF FIGURES

| | |
|---|----|
| Figure 1 Parallel interface timing characteristics (8080 series MCU interface)..... | 23 |
| Figure 2 Rising and falling timing for input and output signal..... | 24 |
| Figure 3 Chip selection (CSX) timing | 24 |
| Figure 4 Write-to-read and read-to-write timing..... | 24 |
| Figure 5 Parallel Interface Timing Characteristics (6800-Series MCU Interface) | 25 |
| Figure 6 3-line serial interface timing..... | 27 |
| Figure 7 4-line serial interface timing..... | 28 |
| Figure 8 8080-series WRX protocol | 31 |
| Figure 9 8080-series parallel bus protocol, write to register or display RAM | 31 |
| Figure 10 8080-series RDX protocol | 32 |
| Figure 11 8080-series parallel bus protocol, read data from register or display RAM | 32 |
| Figure 12 6800-Series Write Protocol | 34 |
| Figure 13 6800-series parallel bus protocol, write to register or display RAM | 34 |
| Figure 14 6800-series read protocol..... | 35 |
| Figure 15 6800-series parallel bus protocol, read data form register or display RAM | 35 |
| Figure 16 Serial interface data stream format | 37 |
| Figure 17 3-line serial interface write protocol (write to register with control bit in transmission) | 37 |
| Figure 18 4-line serial interface write protocol (write to register with control bit in transmission) | 37 |
| Figure 19 3-line serial interface read protocol | 38 |
| Figure 20 4-line serial interface read protocol | 39 |
| Figure 21 Serial bus protocol, write mode–interrupted by RESX..... | 40 |
| Figure 22 Serial bus protocol, write mode–interrupted by CSX | 40 |
| Figure 23 Write interrupts recovery (serial interface) | 41 |
| Figure 24 Write interrupts recovery (both serial and parallel Interface) | 41 |
| Figure 25 Serial interface pause protocol (pause by CSX) | 42 |
| Figure 26 Parallel bus pause protocol (paused by CSX) | 42 |
| Figure 27 Display data RAM organization | 59 |
| Figure 28 Data streaming order..... | 67 |

LIST OF TABLES

| | |
|---|-----|
| Table 1 Absolute Operation Range | 20 |
| Table 2 DC Characteristic..... | 21 |
| Table 3 Power Consumption | 22 |
| Table 4 8080 Parallel Interface Characteristics..... | 24 |
| Table 5 6800 Parallel Interface Characteristics..... | 26 |
| Table 6 3-line Serial Interface Characteristics..... | 27 |
| Table 7 4-line Serial Interface Characteristics..... | 28 |
| Table 8 Interface Type Selection | 29 |
| Table 9 Pin Connection According to Various MCU Interface..... | 29 |
| Table 10 The Function of 8080-series Parallel Interface..... | 30 |
| Table 11 The Function of 6800-series Parallel Interface..... | 33 |
| Table 12 Selection of Serial Interface..... | 36 |
| Table 13 AC characteristics of Tearing Effect Signal Idle Mode Off (Frame Rate = 60 Hz, Ta=25°C)..... | 74 |
| Table 14 Reset Timing..... | 85 |
| Table 15 System Function Command List (1) | 96 |
| Table 16 System Function Command List (2) | 97 |
| Table 17 System Function command List (3)..... | 98 |
| Table 18 Panel Function Command List (1)..... | 147 |
| Table 19 Panel Function Command List (2)..... | 148 |
| Table 20 Panel Function Command List (3)..... | 149 |
| Table 21 Panel Function Command List (4)..... | 150 |

1 GENERAL DESCRIPTION

The ST7735S is a single-chip controller/driver for 262K-color, graphic type TFT-LCD. It consists of 396 source line and 162 gate line driving circuits. This chip is capable of connecting directly to an external microprocessor, and accepts Serial Peripheral Interface (SPI), 8-bit/9-bit/16-bit/18-bit parallel interface. Display data can be stored in the on-chip display data RAM of 132 x 162 x 18 bits. It can perform display data RAM read/write operation with no external operation clock to minimize power consumption. In addition, because of the integrated power supply circuits necessary to drive liquid crystal, it is possible to make a display system with fewer components.

2 FEATURES

Single Chip TFT-LCD Controller/Driver with RAM On-chip Display Data RAM (i.e. Frame Memory)

132 (H) x RGB x 162 (V) Bits

LCD Driver Output Circuits:

Source Outputs: 132 RGB Channels

Gate Outputs: 162 Channels

Common Electrode Output

Display Colors (Color Mode)

Full Color: 262K, RGB=(666) Max., Idle Mode OFF

Color Reduce: 8-color, RGB=(111), Idle Mode ON

Programmable Pixel Color Format (Color Depth) for Various Display Data input Format

12-bit/pixel: RGB=(444) Using the 384k-bit Frame Memory and LUT

16-bit/pixel: RGB=(565) Using the 384k-bit Frame Memory and LUT

18-bit/pixel: RGB=(666) Using the 384k-bit Frame Memory and LUT

Various Interfaces

Parallel 8080-series MCU Interface

(8-bit, 9-bit, 16-bit & 18-bit)

Parallel 6800-series MCU Interface

(8-bit, 9-bit, 16-bit & 18-bit)

3-line Serial Interface

4-line Serial Interface

Display Features

Support Both Normal-black & Normal-white LC

Software Programmable Color Depth Mode

Partial Window Moving & Data Scrolling

Built-in Circuits

DC/DC Converter

Adjustable VCOM Generation

Non-volatile (NV) Memory to Store Initial Register Setting

Oscillator for Display Clock Generation

Factory default value (module ID, module version, etc) are stored in NV memory.

Timing Controller

Built-in NV Memory for LCD Initial Register Setting

7-bits for ID2

8-bits for ID3

7-bits for VCOM Offset Adjustment

Wide Supply Voltage Range

I/O Voltage (VDDI to DGND): 1.65V~3.7V ($VDDI \leq VDD$)

Analog Voltage (VDD to AGND): 2.5V~4.8V

On-Chip Power System

Source Voltage (GVDD to AGND): 3.15V to 5V

VCOM level (VCOM to AGND): -0.425V to -2.0V

Gate Driver HIGH Level (VGH to AGND): +10.0V to +15V

Gate Driver LOW Level (VGL to AGND): -13V to -7.5V

Operating Temperature: -30°C to +85°C

3 PAD ARRANGEMENT

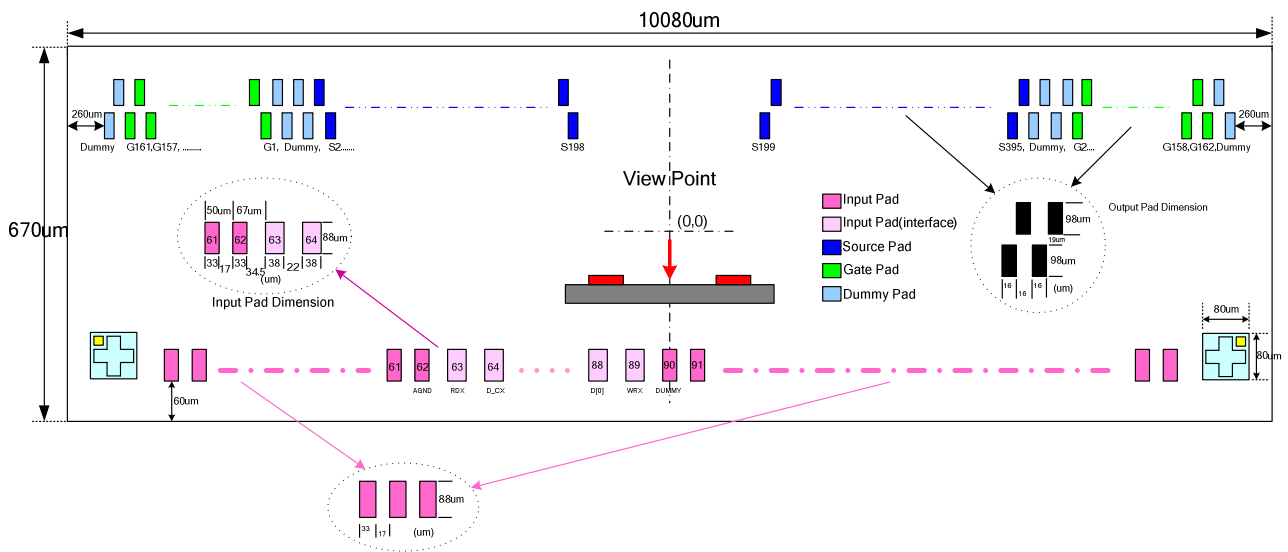

3.1 Output Bump Dimension

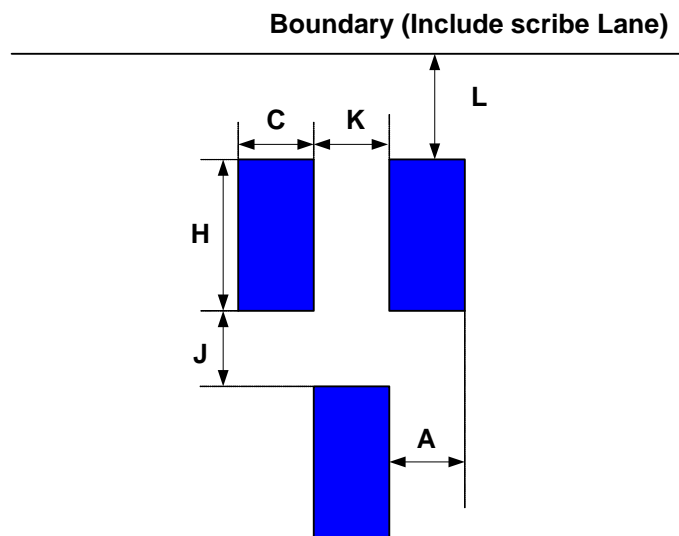

| Item | Symbol | Size |
|-------------------------------------|--------|----------------------|
| Bump Pitch | A | 16 um |
| Bump Width | C | 16 um |
| Bump Height | H | 98 um |
| Bump Gap1 (Vertical) | J | 19 um |
| Bump Gap2 (Horizontal) | K | 16 um |
| Bump Area | C x H | 1568 um ² |
| Chip Boundary (Include Scribe Lane) | L | 59 um |

3.2 Input Bump Dimension

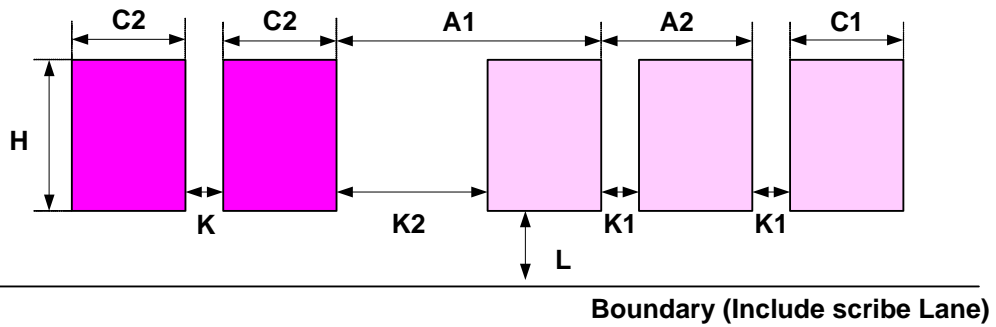

| Item | Symbol | Size |
|------------------------------------|--------|----------------------|
| Bump Pitch 1 | A1 | 72.5 um |
| Bump Pitch 2 | A2 | 60 um |
| Bump Width 1 | C1 | 38 um |
| Bump Width 2 | C2 | 33 um |
| Bump Height | H | 88 um |
| Bump Gap | K | 17 um |
| Bump Gap1 | K1 | 22 um |
| Bump Gap2 | K2 | 34.5 um |
| Bump Area 1 | C1 X H | 3344 um ² |
| Bump Area 2 | C2 X H | 2904 um ² |
| Chip Boundary(Include Scribe Lane) | L | 60 um |

3.3 Alignment Mark Dimension

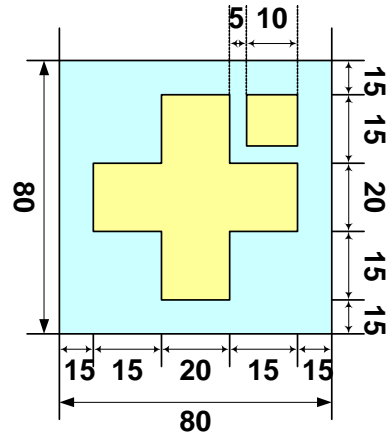
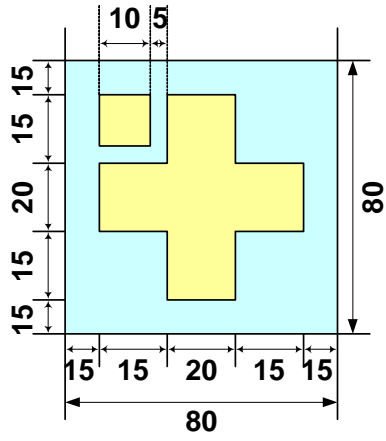

3.4 Chip Information

Chip Size (um x um): 10080 x 670

PAD Coordinate: Pad Center

Coordinate Origin: Chip Center

Chip Thickness (um): 300(TYP)

Bump Height (um): 12(TYP)

Bump Hardness (HV): 75(TYP)

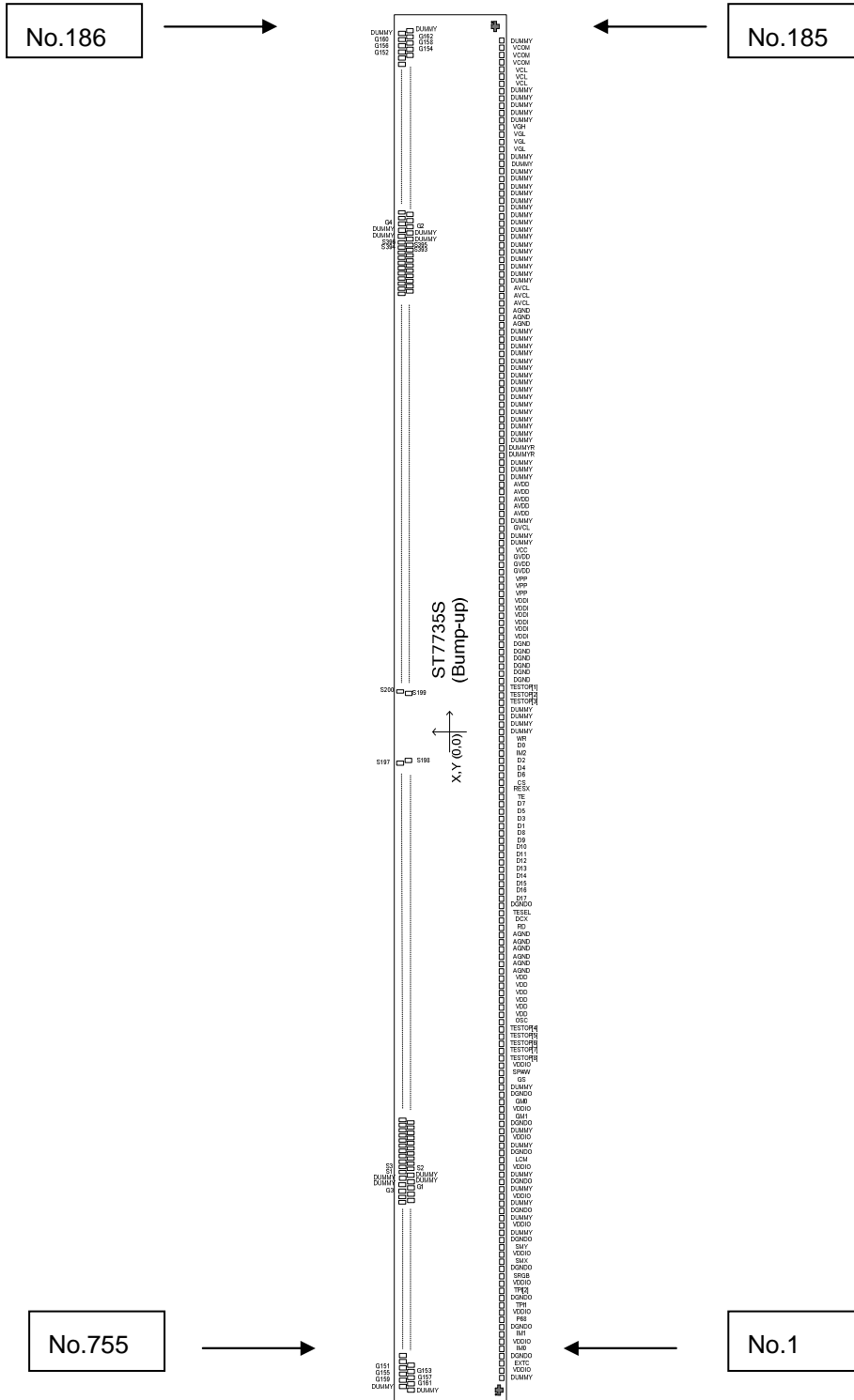

4 PAD CENTER COORDINATES

| No. | PAD Name | X | Y |
|-----|-----------|-------|------|
| 1 | Dummy | -4750 | -231 |
| 2 | VDDIO | -4700 | -231 |
| 3 | EXTC | -4650 | -231 |
| 4 | DGNDO | -4600 | -231 |
| 5 | IM0 | -4550 | -231 |
| 6 | VDDIO | -4500 | -231 |
| 7 | IM1 | -4450 | -231 |
| 8 | DGNDO | -4400 | -231 |
| 9 | P68 | -4350 | -231 |
| 10 | VDDIO | -4300 | -231 |
| 11 | TEST1P | -4250 | -231 |
| 12 | DGNDO | -4200 | -231 |
| 13 | TEST2P | -4150 | -231 |
| 14 | VDDIO | -4100 | -231 |
| 15 | SRGB | -4050 | -231 |
| 16 | DGNDO | -4000 | -231 |
| 17 | SMX | -3950 | -231 |
| 18 | VDDIO | -3900 | -231 |
| 19 | SMY | -3850 | -231 |
| 20 | DGNDO | -3800 | -231 |
| 21 | Dummy | -3750 | -231 |
| 22 | VDDIO | -3700 | -231 |
| 23 | Dummy | -3650 | -231 |
| 24 | DGNDO | -3600 | -231 |
| 25 | Dummy | -3550 | -231 |
| 26 | VDDIO | -3500 | -231 |
| 27 | Dummy | -3450 | -231 |
| 28 | DGNDO | -3400 | -231 |
| 29 | Dummy | -3350 | -231 |
| 30 | VDDIO | -3300 | -231 |
| 31 | LCM | -3250 | -231 |
| 32 | DGNDO | -3200 | -231 |
| 33 | DUMMY | -3150 | -231 |
| 34 | VDDIO | -3100 | -231 |
| 35 | Dummy | -3050 | -231 |
| 36 | DGNDO | -3000 | -231 |
| 37 | GM1 | -2950 | -231 |
| 38 | VDDIO | -2900 | -231 |
| 39 | GM0 | -2850 | -231 |
| 40 | DGNDO | -2800 | -231 |
| 41 | Dummy | -2750 | -231 |
| 42 | GS | -2700 | -231 |
| 43 | SPI4W | -2650 | -231 |
| 44 | VDDIO | -2600 | -231 |
| 45 | TESTOP[8] | -2550 | -231 |
| 46 | TESTOP[7] | -2500 | -231 |
| 47 | TESTOP[6] | -2450 | -231 |
| 48 | TESTOP[5] | -2400 | -231 |
| 49 | TESTOP[4] | -2350 | -231 |
| 50 | OSCP | -2300 | -231 |

| No. | PAD Name | X | Y |
|-----|-----------|-------|------|
| 51 | VDD | -2250 | -231 |
| 52 | VDD | -2200 | -231 |
| 53 | VDD | -2150 | -231 |
| 54 | VDD | -2100 | -231 |
| 55 | VDD | -2050 | -231 |
| 56 | VDD | -2000 | -231 |
| 57 | AGND | -1950 | -231 |
| 58 | AGND | -1900 | -231 |
| 59 | AGND | -1850 | -231 |
| 60 | AGND | -1800 | -231 |
| 61 | AGND | -1750 | -231 |
| 62 | AGND | -1700 | -231 |
| 63 | RDX | -1630 | -231 |
| 64 | D_CX | -1570 | -231 |
| 65 | TESEL | -1510 | -231 |
| 66 | DGNDO | -1450 | -231 |
| 67 | D17 | -1390 | -231 |
| 68 | D16 | -1330 | -231 |
| 69 | D15 | -1270 | -231 |
| 70 | D14 | -1210 | -231 |
| 71 | D13 | -1150 | -231 |
| 72 | D12 | -1090 | -231 |
| 73 | D11 | -1030 | -231 |
| 74 | D10 | -970 | -231 |
| 75 | D9 | -910 | -231 |
| 76 | D8 | -850 | -231 |
| 77 | D1 | -790 | -231 |
| 78 | D3 | -730 | -231 |
| 79 | D5 | -670 | -231 |
| 80 | D7 | -610 | -231 |
| 81 | TE | -550 | -231 |
| 82 | RESX | -490 | -231 |
| 83 | CSX | -430 | -231 |
| 84 | D6 | -370 | -231 |
| 85 | D4 | -310 | -231 |
| 86 | D2 | -250 | -231 |
| 87 | IM2 | -190 | -231 |
| 88 | D0 | -130 | -231 |
| 89 | WRX | -70 | -231 |
| 90 | Dummy | 0 | -231 |
| 91 | Dummy | 50 | -231 |
| 92 | Dummy | 100 | -231 |
| 93 | Dummy | 150 | -231 |
| 94 | TESTOP[3] | 200 | -231 |
| 95 | TESTOP[2] | 250 | -231 |
| 96 | TESTOP[1] | 300 | -231 |
| 97 | DGND | 350 | -231 |
| 98 | DGND | 400 | -231 |
| 99 | DGND | 450 | -231 |
| 100 | DGND | 500 | -231 |

| No. | PAD Name | X | Y |
|-----|----------|------|------|
| 101 | DGND | 550 | -231 |
| 102 | DGND | 600 | -231 |
| 103 | VDDI | 650 | -231 |
| 104 | VDDI | 700 | -231 |
| 105 | VDDI | 750 | -231 |
| 106 | VDDI | 800 | -231 |
| 107 | VDDI | 850 | -231 |
| 108 | VDDI | 900 | -231 |
| 109 | VPP | 950 | -231 |
| 110 | VPP | 1000 | -231 |
| 111 | VPP | 1050 | -231 |
| 112 | GVDD | 1100 | -231 |
| 113 | GVDD | 1150 | -231 |
| 114 | GVDD | 1200 | -231 |
| 115 | VCC | 1250 | -231 |
| 116 | Dummy | 1300 | -231 |
| 117 | Dummy | 1350 | -231 |
| 118 | GVCL | 1400 | -231 |
| 119 | Dummy | 1450 | -231 |
| 120 | AVDD | 1500 | -231 |
| 121 | AVDD | 1550 | -231 |
| 122 | AVDD | 1600 | -231 |
| 123 | AVDD | 1650 | -231 |
| 124 | AVDD | 1700 | -231 |
| 125 | Dummy | 1750 | -231 |
| 126 | Dummy | 1800 | -231 |
| 127 | Dummy | 1850 | -231 |
| 128 | DummyR | 1900 | -231 |
| 129 | DummyR | 1950 | -231 |
| 130 | Dummy | 2000 | -231 |
| 131 | Dummy | 2050 | -231 |
| 132 | Dummy | 2100 | -231 |
| 133 | Dummy | 2150 | -231 |
| 134 | Dummy | 2200 | -231 |
| 135 | Dummy | 2250 | -231 |
| 136 | Dummy | 2300 | -231 |
| 137 | Dummy | 2350 | -231 |
| 138 | Dummy | 2400 | -231 |
| 139 | Dummy | 2450 | -231 |
| 140 | Dummy | 2500 | -231 |
| 141 | Dummy | 2550 | -231 |
| 142 | Dummy | 2600 | -231 |
| 143 | Dummy | 2650 | -231 |
| 144 | Dummy | 2700 | -231 |
| 145 | Dummy | 2750 | -231 |
| 146 | AGND | 2800 | -231 |
| 147 | AGND | 2850 | -231 |
| 148 | AGND | 2900 | -231 |
| 149 | AVCL | 2950 | -231 |
| 150 | AVCL | 3000 | -231 |

| No. | PAD Name | X | Y |
|-----|----------|------|------|
| 151 | AVCL | 3050 | -231 |
| 152 | Dummy | 3100 | -231 |
| 153 | Dummy | 3150 | -231 |
| 154 | Dummy | 3200 | -231 |
| 155 | Dummy | 3250 | -231 |
| 156 | Dummy | 3300 | -231 |
| 157 | Dummy | 3350 | -231 |
| 158 | Dummy | 3400 | -231 |
| 159 | Dummy | 3450 | -231 |
| 160 | Dummy | 3500 | -231 |
| 161 | Dummy | 3550 | -231 |
| 162 | Dummy | 3600 | -231 |
| 163 | Dummy | 3650 | -231 |
| 164 | Dummy | 3700 | -231 |
| 165 | Dummy | 3750 | -231 |
| 166 | Dummy | 3800 | -231 |
| 167 | Dummy | 3850 | -231 |
| 168 | Dummy | 3900 | -231 |
| 169 | Dummy | 3950 | -231 |
| 170 | VGL | 4000 | -231 |
| 171 | VGL | 4050 | -231 |
| 172 | VGL | 4100 | -231 |
| 173 | VGH | 4150 | -231 |
| 174 | Dummy | 4200 | -231 |
| 175 | Dummy | 4250 | -231 |
| 176 | Dummy | 4300 | -231 |
| 177 | Dummy | 4350 | -231 |
| 178 | Dummy | 4400 | -231 |
| 179 | VCL | 4450 | -231 |
| 180 | VCL | 4500 | -231 |
| 181 | VCL | 4550 | -231 |
| 182 | VCOM | 4600 | -231 |
| 183 | VCOM | 4650 | -231 |
| 184 | VCOM | 4700 | -231 |
| 185 | Dummy | 4750 | -231 |
| 186 | Dummy | 4772 | 110 |
| 187 | Dummy | 4756 | 227 |
| 188 | G162 | 4740 | 110 |
| 189 | G160 | 4724 | 227 |
| 190 | G158 | 4708 | 110 |
| 191 | G156 | 4692 | 227 |
| 192 | G154 | 4676 | 110 |
| 193 | G152 | 4660 | 227 |
| 194 | G150 | 4644 | 110 |
| 195 | G148 | 4628 | 227 |
| 196 | G146 | 4612 | 110 |
| 197 | G144 | 4596 | 227 |
| 198 | G142 | 4580 | 110 |
| 199 | G140 | 4564 | 227 |
| 200 | G138 | 4548 | 110 |

| No. | PAD Name | X | Y |
|-----|----------|------|-----|
| 201 | G136 | 4532 | 227 |
| 202 | G134 | 4516 | 110 |
| 203 | G132 | 4500 | 227 |
| 204 | G130 | 4484 | 110 |
| 205 | G128 | 4468 | 227 |
| 206 | G126 | 4452 | 110 |
| 207 | G124 | 4436 | 227 |
| 208 | G122 | 4420 | 110 |
| 209 | G120 | 4404 | 227 |
| 210 | G118 | 4388 | 110 |
| 211 | G116 | 4372 | 227 |
| 212 | G114 | 4356 | 110 |
| 213 | G112 | 4340 | 227 |
| 214 | G110 | 4324 | 110 |
| 215 | G108 | 4308 | 227 |
| 216 | G106 | 4292 | 110 |
| 217 | G104 | 4276 | 227 |
| 218 | G102 | 4260 | 110 |
| 219 | G100 | 4244 | 227 |
| 220 | G98 | 4228 | 110 |
| 221 | G96 | 4212 | 227 |
| 222 | G94 | 4196 | 110 |
| 223 | G92 | 4180 | 227 |
| 224 | G90 | 4164 | 110 |
| 225 | G88 | 4148 | 227 |
| 226 | G86 | 4132 | 110 |
| 227 | G84 | 4116 | 227 |
| 228 | G82 | 4100 | 110 |
| 229 | G80 | 4084 | 227 |
| 230 | G78 | 4068 | 110 |
| 231 | G76 | 4052 | 227 |
| 232 | G74 | 4036 | 110 |
| 233 | G72 | 4020 | 227 |
| 234 | G70 | 4004 | 110 |
| 235 | G68 | 3988 | 227 |
| 236 | G66 | 3972 | 110 |
| 237 | G64 | 3956 | 227 |
| 238 | G62 | 3940 | 110 |
| 239 | G60 | 3924 | 227 |
| 240 | G58 | 3908 | 110 |
| 241 | G56 | 3892 | 227 |
| 242 | G54 | 3876 | 110 |
| 243 | G52 | 3860 | 227 |
| 244 | G50 | 3844 | 110 |
| 245 | G48 | 3828 | 227 |
| 246 | G46 | 3812 | 110 |
| 247 | G44 | 3796 | 227 |
| 248 | G42 | 3780 | 110 |
| 249 | G40 | 3764 | 227 |
| 250 | G38 | 3748 | 110 |

| No. | PAD Name | X | Y |
|-----|----------|------|-----|
| 251 | G36 | 3732 | 227 |
| 252 | G34 | 3716 | 110 |
| 253 | G32 | 3700 | 227 |
| 254 | G30 | 3684 | 110 |
| 255 | G28 | 3668 | 227 |
| 256 | G26 | 3652 | 110 |
| 257 | G24 | 3636 | 227 |
| 258 | G22 | 3620 | 110 |
| 259 | G20 | 3604 | 227 |
| 260 | G18 | 3588 | 110 |
| 261 | G16 | 3572 | 227 |
| 262 | G14 | 3556 | 110 |
| 263 | G12 | 3540 | 227 |
| 264 | G10 | 3524 | 110 |
| 265 | G8 | 3508 | 227 |
| 266 | G6 | 3492 | 110 |
| 267 | G4 | 3476 | 227 |
| 268 | G2 | 3460 | 110 |
| 269 | Dummy | 3444 | 227 |
| 270 | Dummy | 3428 | 110 |
| 271 | Dummy | 3412 | 227 |
| 272 | Dummy | 3396 | 110 |
| 273 | S396 | 3380 | 227 |
| 274 | S395 | 3364 | 110 |
| 275 | S394 | 3348 | 227 |
| 276 | S393 | 3332 | 110 |
| 277 | S392 | 3316 | 227 |
| 278 | S391 | 3300 | 110 |
| 279 | S390 | 3284 | 227 |
| 280 | S389 | 3268 | 110 |
| 281 | S388 | 3252 | 227 |
| 282 | S387 | 3236 | 110 |
| 283 | S386 | 3220 | 227 |
| 284 | S385 | 3204 | 110 |
| 285 | S384 | 3188 | 227 |
| 286 | S383 | 3172 | 110 |
| 287 | S382 | 3156 | 227 |
| 288 | S381 | 3140 | 110 |
| 289 | S380 | 3124 | 227 |
| 290 | S379 | 3108 | 110 |
| 291 | S378 | 3092 | 227 |
| 292 | S377 | 3076 | 110 |
| 293 | S376 | 3060 | 227 |
| 294 | S375 | 3044 | 110 |
| 295 | S374 | 3028 | 227 |
| 296 | S373 | 3012 | 110 |
| 297 | S372 | 2996 | 227 |
| 298 | S371 | 2980 | 110 |
| 299 | S370 | 2964 | 227 |
| 300 | S369 | 2948 | 110 |

| No. | PAD Name | X | Y |
|-----|----------|------|-----|
| 301 | S368 | 2932 | 227 |
| 302 | S367 | 2916 | 110 |
| 303 | S366 | 2900 | 227 |
| 304 | S365 | 2884 | 110 |
| 305 | S364 | 2868 | 227 |
| 306 | S363 | 2852 | 110 |
| 307 | S362 | 2836 | 227 |
| 308 | S361 | 2820 | 110 |
| 309 | S360 | 2804 | 227 |
| 310 | S359 | 2788 | 110 |
| 311 | S358 | 2772 | 227 |
| 312 | S357 | 2756 | 110 |
| 313 | S356 | 2740 | 227 |
| 314 | S355 | 2724 | 110 |
| 315 | S354 | 2708 | 227 |
| 316 | S353 | 2692 | 110 |
| 317 | S352 | 2676 | 227 |
| 318 | S351 | 2660 | 110 |
| 319 | S350 | 2644 | 227 |
| 320 | S349 | 2628 | 110 |
| 321 | S348 | 2612 | 227 |
| 322 | S347 | 2596 | 110 |
| 323 | S346 | 2580 | 227 |
| 324 | S345 | 2564 | 110 |
| 325 | S344 | 2548 | 227 |
| 326 | S343 | 2532 | 110 |
| 327 | S342 | 2516 | 227 |
| 328 | S341 | 2500 | 110 |
| 329 | S340 | 2484 | 227 |
| 330 | S339 | 2468 | 110 |
| 331 | S338 | 2452 | 227 |
| 332 | S337 | 2436 | 110 |
| 333 | S336 | 2420 | 227 |
| 334 | S335 | 2404 | 110 |
| 335 | S334 | 2388 | 227 |
| 336 | S333 | 2372 | 110 |
| 337 | S332 | 2356 | 227 |
| 338 | S331 | 2340 | 110 |
| 339 | S330 | 2324 | 227 |
| 340 | S329 | 2308 | 110 |
| 341 | S328 | 2292 | 227 |
| 342 | S327 | 2276 | 110 |
| 343 | S326 | 2260 | 227 |
| 344 | S325 | 2244 | 110 |
| 345 | S324 | 2228 | 227 |
| 346 | S323 | 2212 | 110 |
| 347 | S322 | 2196 | 227 |
| 348 | S321 | 2180 | 110 |
| 349 | S320 | 2164 | 227 |
| 350 | S319 | 2148 | 110 |

| No. | PAD Name | X | Y |
|-----|----------|------|-----|
| 351 | S318 | 2132 | 227 |
| 352 | S317 | 2116 | 110 |
| 353 | S316 | 2100 | 227 |
| 354 | S315 | 2084 | 110 |
| 355 | S314 | 2068 | 227 |
| 356 | S313 | 2052 | 110 |
| 357 | S312 | 2036 | 227 |
| 358 | S311 | 2020 | 110 |
| 359 | S310 | 2004 | 227 |
| 360 | S309 | 1988 | 110 |
| 361 | S308 | 1972 | 227 |
| 362 | S307 | 1956 | 110 |
| 363 | S306 | 1940 | 227 |
| 364 | S305 | 1924 | 110 |
| 365 | S304 | 1908 | 227 |
| 366 | S303 | 1892 | 110 |
| 367 | S302 | 1876 | 227 |
| 368 | S301 | 1860 | 110 |
| 369 | S300 | 1844 | 227 |
| 370 | S299 | 1828 | 110 |
| 371 | S298 | 1812 | 227 |
| 372 | S297 | 1796 | 110 |
| 373 | S296 | 1780 | 227 |
| 374 | S295 | 1764 | 110 |
| 375 | S294 | 1748 | 227 |
| 376 | S293 | 1732 | 110 |
| 377 | S292 | 1716 | 227 |
| 378 | S291 | 1700 | 110 |
| 379 | S290 | 1684 | 227 |
| 380 | S289 | 1668 | 110 |
| 381 | S288 | 1652 | 227 |
| 382 | S287 | 1636 | 110 |
| 383 | S286 | 1620 | 227 |
| 384 | S285 | 1604 | 110 |
| 385 | S284 | 1588 | 227 |
| 386 | S283 | 1572 | 110 |
| 387 | S282 | 1556 | 227 |
| 388 | S281 | 1540 | 110 |
| 389 | S280 | 1524 | 227 |
| 390 | S279 | 1508 | 110 |
| 391 | S278 | 1492 | 227 |
| 392 | S277 | 1476 | 110 |
| 393 | S276 | 1460 | 227 |
| 394 | S275 | 1444 | 110 |
| 395 | S274 | 1428 | 227 |
| 396 | S273 | 1412 | 110 |
| 397 | S272 | 1396 | 227 |
| 398 | S271 | 1380 | 110 |
| 399 | S270 | 1364 | 227 |
| 400 | S269 | 1348 | 110 |

| No. | PAD Name | X | Y |
|-----|----------|------|-----|
| 401 | S268 | 1332 | 227 |
| 402 | S267 | 1316 | 110 |
| 403 | S266 | 1300 | 227 |
| 404 | S265 | 1284 | 110 |
| 405 | S264 | 1268 | 227 |
| 406 | S263 | 1252 | 110 |
| 407 | S262 | 1236 | 227 |
| 408 | S261 | 1220 | 110 |
| 409 | S260 | 1204 | 227 |
| 410 | S259 | 1188 | 110 |
| 411 | S258 | 1172 | 227 |
| 412 | S257 | 1156 | 110 |
| 413 | S256 | 1140 | 227 |
| 414 | S255 | 1124 | 110 |
| 415 | S254 | 1108 | 227 |
| 416 | S253 | 1092 | 110 |
| 417 | S252 | 1076 | 227 |
| 418 | S251 | 1060 | 110 |
| 419 | S250 | 1044 | 227 |
| 420 | S249 | 1028 | 110 |
| 421 | S248 | 1012 | 227 |
| 422 | S247 | 996 | 110 |
| 423 | S246 | 980 | 227 |
| 424 | S245 | 964 | 110 |
| 425 | S244 | 948 | 227 |
| 426 | S243 | 932 | 110 |
| 427 | S242 | 916 | 227 |
| 428 | S241 | 900 | 110 |
| 429 | S240 | 884 | 227 |
| 430 | S239 | 868 | 110 |
| 431 | S238 | 852 | 227 |
| 432 | S237 | 836 | 110 |
| 433 | S236 | 820 | 227 |
| 434 | S235 | 804 | 110 |
| 435 | S234 | 788 | 227 |
| 436 | S233 | 772 | 110 |
| 437 | S232 | 756 | 227 |
| 438 | S231 | 740 | 110 |
| 439 | S230 | 724 | 227 |
| 440 | S229 | 708 | 110 |
| 441 | S228 | 692 | 227 |
| 442 | S227 | 676 | 110 |
| 443 | S226 | 660 | 227 |
| 444 | S225 | 644 | 110 |
| 445 | S224 | 628 | 227 |
| 446 | S223 | 612 | 110 |
| 447 | S222 | 596 | 227 |
| 448 | S221 | 580 | 110 |
| 449 | S220 | 564 | 227 |
| 450 | S219 | 548 | 110 |

| No. | PAD Name | X | Y |
|-----|----------|------|-----|
| 451 | S218 | 532 | 227 |
| 452 | S217 | 516 | 110 |
| 453 | S216 | 500 | 227 |
| 454 | S215 | 484 | 110 |
| 455 | S214 | 468 | 227 |
| 456 | S213 | 452 | 110 |
| 457 | S212 | 436 | 227 |
| 458 | S211 | 420 | 110 |
| 459 | S210 | 404 | 227 |
| 460 | S209 | 388 | 110 |
| 461 | S208 | 372 | 227 |
| 462 | S207 | 356 | 110 |
| 463 | S206 | 340 | 227 |
| 464 | S205 | 324 | 110 |
| 465 | S204 | 308 | 227 |
| 466 | S203 | 292 | 110 |
| 467 | S202 | 276 | 227 |
| 468 | S201 | 260 | 110 |
| 469 | S200 | 244 | 227 |
| 470 | S199 | 228 | 110 |
| 471 | S198 | -228 | 110 |
| 472 | S197 | -244 | 227 |
| 473 | S196 | -260 | 110 |
| 474 | S195 | -276 | 227 |
| 475 | S194 | -292 | 110 |
| 476 | S193 | -308 | 227 |
| 477 | S192 | -324 | 110 |
| 478 | S191 | -340 | 227 |
| 479 | S190 | -356 | 110 |
| 480 | S189 | -372 | 227 |
| 481 | S188 | -388 | 110 |
| 482 | S187 | -404 | 227 |
| 483 | S186 | -420 | 110 |
| 484 | S185 | -436 | 227 |
| 485 | S184 | -452 | 110 |
| 486 | S183 | -468 | 227 |
| 487 | S182 | -484 | 110 |
| 488 | S181 | -500 | 227 |
| 489 | S180 | -516 | 110 |
| 490 | S179 | -532 | 227 |
| 491 | S178 | -548 | 110 |
| 492 | S177 | -564 | 227 |
| 493 | S176 | -580 | 110 |
| 494 | S175 | -596 | 227 |
| 495 | S174 | -612 | 110 |
| 496 | S173 | -628 | 227 |
| 497 | S172 | -644 | 110 |
| 498 | S171 | -660 | 227 |
| 499 | S170 | -676 | 110 |
| 500 | S169 | -692 | 227 |

| No. | PAD Name | X | Y |
|-----|----------|-------|-----|
| 501 | S168 | -708 | 110 |
| 502 | S167 | -724 | 227 |
| 503 | S166 | -740 | 110 |
| 504 | S165 | -756 | 227 |
| 505 | S164 | -772 | 110 |
| 506 | S163 | -788 | 227 |
| 507 | S162 | -804 | 110 |
| 508 | S161 | -820 | 227 |
| 509 | S160 | -836 | 110 |
| 510 | S159 | -852 | 227 |
| 511 | S158 | -868 | 110 |
| 512 | S157 | -884 | 227 |
| 513 | S156 | -900 | 110 |
| 514 | S155 | -916 | 227 |
| 515 | S154 | -932 | 110 |
| 516 | S153 | -948 | 227 |
| 517 | S152 | -964 | 110 |
| 518 | S151 | -980 | 227 |
| 519 | S150 | -996 | 110 |
| 520 | S149 | -1012 | 227 |
| 521 | S148 | -1028 | 110 |
| 522 | S147 | -1044 | 227 |
| 523 | S146 | -1060 | 110 |
| 524 | S145 | -1076 | 227 |
| 525 | S144 | -1092 | 110 |
| 526 | S143 | -1108 | 227 |
| 527 | S142 | -1124 | 110 |
| 528 | S141 | -1140 | 227 |
| 529 | S140 | -1156 | 110 |
| 530 | S139 | -1172 | 227 |
| 531 | S138 | -1188 | 110 |
| 532 | S137 | -1204 | 227 |
| 533 | S136 | -1220 | 110 |
| 534 | S135 | -1236 | 227 |
| 535 | S134 | -1252 | 110 |
| 536 | S133 | -1268 | 227 |
| 537 | S132 | -1284 | 110 |
| 538 | S131 | -1300 | 227 |
| 539 | S130 | -1316 | 110 |
| 540 | S129 | -1332 | 227 |
| 541 | S128 | -1348 | 110 |
| 542 | S127 | -1364 | 227 |
| 543 | S126 | -1380 | 110 |
| 544 | S125 | -1396 | 227 |
| 545 | S124 | -1412 | 110 |
| 546 | S123 | -1428 | 227 |
| 547 | S122 | -1444 | 110 |
| 548 | S121 | -1460 | 227 |
| 549 | S120 | -1476 | 110 |
| 550 | S119 | -1492 | 227 |

| No. | PAD Name | X | Y |
|-----|----------|-------|-----|
| 551 | S118 | -1508 | 110 |
| 552 | S117 | -1524 | 227 |
| 553 | S116 | -1540 | 110 |
| 554 | S115 | -1556 | 227 |
| 555 | S114 | -1572 | 110 |
| 556 | S113 | -1588 | 227 |
| 557 | S112 | -1604 | 110 |
| 558 | S111 | -1620 | 227 |
| 559 | S110 | -1636 | 110 |
| 560 | S109 | -1652 | 227 |
| 561 | S108 | -1668 | 110 |
| 562 | S107 | -1684 | 227 |
| 563 | S106 | -1700 | 110 |
| 564 | S105 | -1716 | 227 |
| 565 | S104 | -1732 | 110 |
| 566 | S103 | -1748 | 227 |
| 567 | S102 | -1764 | 110 |
| 568 | S101 | -1780 | 227 |
| 569 | S100 | -1796 | 110 |
| 570 | S99 | -1812 | 227 |
| 571 | S98 | -1828 | 110 |
| 572 | S97 | -1844 | 227 |
| 573 | S96 | -1860 | 110 |
| 574 | S95 | -1876 | 227 |
| 575 | S94 | -1892 | 110 |
| 576 | S93 | -1908 | 227 |
| 577 | S92 | -1924 | 110 |
| 578 | S91 | -1940 | 227 |
| 579 | S90 | -1956 | 110 |
| 580 | S89 | -1972 | 227 |
| 581 | S88 | -1988 | 110 |
| 582 | S87 | -2004 | 227 |
| 583 | S86 | -2020 | 110 |
| 584 | S85 | -2036 | 227 |
| 585 | S84 | -2052 | 110 |
| 586 | S83 | -2068 | 227 |
| 587 | S82 | -2084 | 110 |
| 588 | S81 | -2100 | 227 |
| 589 | S80 | -2116 | 110 |
| 590 | S79 | -2132 | 227 |
| 591 | S78 | -2148 | 110 |
| 592 | S77 | -2164 | 227 |
| 593 | S76 | -2180 | 110 |
| 594 | S75 | -2196 | 227 |
| 595 | S74 | -2212 | 110 |
| 596 | S73 | -2228 | 227 |
| 597 | S72 | -2244 | 110 |
| 598 | S71 | -2260 | 227 |
| 599 | S70 | -2276 | 110 |
| 600 | S69 | -2292 | 227 |

| No. | PAD Name | X | Y |
|-----|----------|-------|-----|
| 601 | S68 | -2308 | 110 |
| 602 | S67 | -2324 | 227 |
| 603 | S66 | -2340 | 110 |
| 604 | S65 | -2356 | 227 |
| 605 | S64 | -2372 | 110 |
| 606 | S63 | -2388 | 227 |
| 607 | S62 | -2404 | 110 |
| 608 | S61 | -2420 | 227 |
| 609 | S60 | -2436 | 110 |
| 610 | S59 | -2452 | 227 |
| 611 | S58 | -2468 | 110 |
| 612 | S57 | -2484 | 227 |
| 613 | S56 | -2500 | 110 |
| 614 | S55 | -2516 | 227 |
| 615 | S54 | -2532 | 110 |
| 616 | S53 | -2548 | 227 |
| 617 | S52 | -2564 | 110 |
| 618 | S51 | -2580 | 227 |
| 619 | S50 | -2596 | 110 |
| 620 | S49 | -2612 | 227 |
| 621 | S48 | -2628 | 110 |
| 622 | S47 | -2644 | 227 |
| 623 | S46 | -2660 | 110 |
| 624 | S45 | -2676 | 227 |
| 625 | S44 | -2692 | 110 |
| 626 | S43 | -2708 | 227 |
| 627 | S42 | -2724 | 110 |
| 628 | S41 | -2740 | 227 |
| 629 | S40 | -2756 | 110 |
| 630 | S39 | -2772 | 227 |
| 631 | S38 | -2788 | 110 |
| 632 | S37 | -2804 | 227 |
| 633 | S36 | -2820 | 110 |
| 634 | S35 | -2836 | 227 |
| 635 | S34 | -2852 | 110 |
| 636 | S33 | -2868 | 227 |
| 637 | S32 | -2884 | 110 |
| 638 | S31 | -2900 | 227 |
| 639 | S30 | -2916 | 110 |
| 640 | S29 | -2932 | 227 |
| 641 | S28 | -2948 | 110 |
| 642 | S27 | -2964 | 227 |
| 643 | S26 | -2980 | 110 |
| 644 | S25 | -2996 | 227 |
| 645 | S24 | -3012 | 110 |
| 646 | S23 | -3028 | 227 |
| 647 | S22 | -3044 | 110 |
| 648 | S21 | -3060 | 227 |
| 649 | S20 | -3076 | 110 |
| 650 | S19 | -3092 | 227 |

| No. | PAD Name | X | Y |
|-----|----------|-------|-----|
| 651 | S18 | -3108 | 110 |
| 652 | S17 | -3124 | 227 |
| 653 | S16 | -3140 | 110 |
| 654 | S15 | -3156 | 227 |
| 655 | S14 | -3172 | 110 |
| 656 | S13 | -3188 | 227 |
| 657 | S12 | -3204 | 110 |
| 658 | S11 | -3220 | 227 |
| 659 | S10 | -3236 | 110 |
| 660 | S9 | -3252 | 227 |
| 661 | S8 | -3268 | 110 |
| 662 | S7 | -3284 | 227 |
| 663 | S6 | -3300 | 110 |
| 664 | S5 | -3316 | 227 |
| 665 | S4 | -3332 | 110 |
| 666 | S3 | -3348 | 227 |
| 667 | S2 | -3364 | 110 |
| 668 | S1 | -3380 | 227 |
| 669 | Dummy | -3396 | 110 |
| 670 | Dummy | -3412 | 227 |
| 671 | Dummy | -3428 | 110 |
| 672 | Dummy | -3444 | 227 |
| 673 | G1 | -3460 | 110 |
| 674 | G3 | -3476 | 227 |
| 675 | G5 | -3492 | 110 |
| 676 | G7 | -3508 | 227 |
| 677 | G9 | -3524 | 110 |
| 678 | G11 | -3540 | 227 |
| 679 | G13 | -3556 | 110 |
| 680 | G15 | -3572 | 227 |
| 681 | G17 | -3588 | 110 |
| 682 | G19 | -3604 | 227 |
| 683 | G21 | -3620 | 110 |
| 684 | G23 | -3636 | 227 |
| 685 | G25 | -3652 | 110 |
| 686 | G27 | -3668 | 227 |
| 687 | G29 | -3684 | 110 |
| 688 | G31 | -3700 | 227 |
| 689 | G33 | -3716 | 110 |
| 690 | G35 | -3732 | 227 |
| 691 | G37 | -3748 | 110 |
| 692 | G39 | -3764 | 227 |
| 693 | G41 | -3780 | 110 |
| 694 | G43 | -3796 | 227 |
| 695 | G45 | -3812 | 110 |
| 696 | G47 | -3828 | 227 |
| 697 | G49 | -3844 | 110 |
| 698 | G51 | -3860 | 227 |
| 699 | G53 | -3876 | 110 |
| 700 | G55 | -3892 | 227 |

| No. | PAD Name | X | Y |
|-----|----------|-------|-----|
| 701 | G57 | -3908 | 110 |
| 702 | G59 | -3924 | 227 |
| 703 | G61 | -3940 | 110 |
| 704 | G63 | -3956 | 227 |
| 705 | G65 | -3972 | 110 |
| 706 | G67 | -3988 | 227 |
| 707 | G69 | -4004 | 110 |
| 708 | G71 | -4020 | 227 |
| 709 | G73 | -4036 | 110 |
| 710 | G75 | -4052 | 227 |
| 711 | G77 | -4068 | 110 |
| 712 | G79 | -4084 | 227 |
| 713 | G81 | -4100 | 110 |
| 714 | G83 | -4116 | 227 |
| 715 | G85 | -4132 | 110 |
| 716 | G87 | -4148 | 227 |
| 717 | G89 | -4164 | 110 |
| 718 | G91 | -4180 | 227 |
| 719 | G93 | -4196 | 110 |
| 720 | G95 | -4212 | 227 |
| 721 | G97 | -4228 | 110 |
| 722 | G99 | -4244 | 227 |
| 723 | G101 | -4260 | 110 |
| 724 | G103 | -4276 | 227 |
| 725 | G105 | -4292 | 110 |
| 726 | G107 | -4308 | 227 |
| 727 | G109 | -4324 | 110 |
| 728 | G111 | -4340 | 227 |
| 729 | G113 | -4356 | 110 |
| 730 | G115 | -4372 | 227 |
| 731 | G117 | -4388 | 110 |
| 732 | G119 | -4404 | 227 |
| 733 | G121 | -4420 | 110 |
| 734 | G123 | -4436 | 227 |
| 735 | G125 | -4452 | 110 |
| 736 | G127 | -4468 | 227 |
| 737 | G129 | -4484 | 110 |
| 738 | G131 | -4500 | 227 |
| 739 | G133 | -4516 | 110 |
| 740 | G135 | -4532 | 227 |
| 741 | G137 | -4548 | 110 |
| 742 | G139 | -4564 | 227 |
| 743 | G141 | -4580 | 110 |
| 744 | G143 | -4596 | 227 |
| 745 | G145 | -4612 | 110 |
| 746 | G147 | -4628 | 227 |
| 747 | G149 | -4644 | 110 |
| 748 | G151 | -4660 | 227 |
| 749 | G153 | -4676 | 110 |
| 750 | G155 | -4692 | 227 |

6 PIN DESCRIPTION

6.1 Power Supply Pin

| Name | I/O | Description | Connect Pin |
|------|-----|--|-------------|
| VDD | I | Power Supply for Analog, Digital System and Booster Circuit. | VDD |
| VDDI | I | Power Supply for I/O system. | VDDI |
| AGND | I | System Ground for Analog System and Booster Circuit. | GND |
| DGND | I | System Ground for I/O System and Digital System. | GND |

6.2 Interface Logic Pin

| Name | I/O | Description | Connect pin | | | | | | | | | | | | | | | |
|---------|-----|---|-------------|-----|--------------------|---|---|--------------------|---|---|---------------------|---|---|--------------------|---|---|---------------------|-----------|
| P68 | I | -8080/6800 MCU Interface Mode Select. -P68='1', Select 6800 MCU Parallel Interface. -P68='0', Select 8080 MCU Parallel Interface. -If not used, Please Fix this Pin at DGND Level. | DGND/VDDI | | | | | | | | | | | | | | | |
| IM2 | I | MCU Parallel Interface Bus and Serial Interface select IM2='1', Parallel Interface IM2='0', Serial Interface | DGND/VDDI | | | | | | | | | | | | | | | |
| IM1,IM0 | I | - MCU Parallel Interface Type Selection -If Not Used, Please Fix this Pin at VDDI or DGND Level. <table border="1" style="margin: 5px auto;"> <thead> <tr> <th>IM1</th> <th>IM0</th> <th>Parallel Interface</th> </tr> </thead> <tbody> <tr> <td>0</td> <td>0</td> <td>MCU 8-bit Parallel</td> </tr> <tr> <td>0</td> <td>1</td> <td>MCU 16-bit Parallel</td> </tr> <tr> <td>1</td> <td>0</td> <td>MCU 9-bit Parallel</td> </tr> <tr> <td>1</td> <td>1</td> <td>MCU 18-bit Parallel</td> </tr> </tbody> </table> | IM1 | IM0 | Parallel Interface | 0 | 0 | MCU 8-bit Parallel | 0 | 1 | MCU 16-bit Parallel | 1 | 0 | MCU 9-bit Parallel | 1 | 1 | MCU 18-bit Parallel | DGND/VDDI |
| IM1 | IM0 | Parallel Interface | | | | | | | | | | | | | | | | |
| 0 | 0 | MCU 8-bit Parallel | | | | | | | | | | | | | | | | |
| 0 | 1 | MCU 16-bit Parallel | | | | | | | | | | | | | | | | |
| 1 | 0 | MCU 9-bit Parallel | | | | | | | | | | | | | | | | |
| 1 | 1 | MCU 18-bit Parallel | | | | | | | | | | | | | | | | |
| SPI4W | I | - SPI4W='0', 3-line SPI Enable. - SPI4W='1', 4-line SPI Enable. -If Not Used, Please fix this Pin at DGND Level. | DGND/VDDI | | | | | | | | | | | | | | | |
| RESX | I | -This signal will reset the device and it must be applied to properly initialize the chip. -Signal is active low. | MCU | | | | | | | | | | | | | | | |
| CSX | I | -Chip Selection Pin -Low Enable. | MCU | | | | | | | | | | | | | | | |

| | | | |
|---------------|-----|--|-----|
| D/CX (SCL) | I | -Display data/command Selection Pin in MCU Interface. -D/CX='1': Display Data or Parameter. -D/CX='0': Command Data. -In Serial Interface, this is used as SCL. -If not used, please fix this pin at VDDI or DGND level. | MCU |
| RDX | I | -Read Enable in 8080 MCU Parallel Interface. -If not used, please fix this pin at VDDI or DGND level. | MCU |
| WRX (D/CX) | I | -Write Enable in MCU Parallel Interface. -In 4-line SPI, this pin is used as D/CX (data/ command selection). -If not used, please fix this pin at VDDI or DGND level. | MCU |
| D[17:0] | I/O | -D[17:0] are used as MCU parallel interface data bus. -D0 is the serial input/output signal in serial interface mode. -In serial interface, D[17:1] are not used and should be fixed at VDDI or DGND level. | MCU |
| TE | O | -Tearing effect output pin to synchronies MCU to frame rate, activated by S/W command. -If not used, please open this pin. | MCU |
| OSC | O | -Monitoring pin of internal oscillator clock and is turned ON/OFF by S/W command. -When this pin is inactive (function OFF), this pin is DGND level. -If not used, please open this pin. | - |

Note1. When in parallel mode, no use data pin must be connected to "1" or "0".

Note2. When CSX="1", there is no influence to the parallel and serial interface.

6.3 Mode Selection Pin

| Name | I/O | Description | Connect Pin | | | | | | | | | | | | | | | | |
|-------------|---|--|-------------|--|--|--------------------------------------|---|---|---|----------|----------|---|------------|------------|---|---|------------|------------|------------|
| EXTC | I | - During normal operation, please connect to VDDI.. | VDDI/DGND | | | | | | | | | | | | | | | | |
| | | <table border="1"> <tr> <td>EXTC</td> <td>Enable/disable Modification of Extend Command</td> </tr> <tr> <td>0</td> <td>Panel Function Commands Disable.</td> </tr> <tr> <td>1</td> <td>Panel Function Commands Enable.</td> </tr> </table> | | EXTC | Enable/disable Modification of Extend Command | 0 | Panel Function Commands Disable. | 1 | Panel Function Commands Enable. | | | | | | | | | | |
| | | EXTC | | Enable/disable Modification of Extend Command | | | | | | | | | | | | | | | |
| 0 | Panel Function Commands Disable. | | | | | | | | | | | | | | | | | | |
| 1 | Panel Function Commands Enable. | | | | | | | | | | | | | | | | | | |
| | | | | | | | | | | | | | | | | | | | |
| GM1, GM0 | I | -Panel Resolution Selection Pins. | VDDI/DGND | | | | | | | | | | | | | | | | |
| | | <table border="1"> <tr> <td>GM1</td> <td>GM0</td> <td>Selection of panel resolution</td> </tr> <tr> <td>0</td> <td>0</td> <td>132RGB x 162 (S1~S396 & G1~G162 output)</td> </tr> <tr> <td>0</td> <td>1</td> <td>132RGB x 132 (S1~S396 & G1~G132 Output)</td> </tr> <tr> <td>1</td> <td>1</td> <td>128RGB x 160 (S7~S390 & G2~G161 output)</td> </tr> </table> | | GM1 | GM0 | Selection of panel resolution | 0 | 0 | 132RGB x 162 (S1~S396 & G1~G162 output) | 0 | 1 | 132RGB x 132 (S1~S396 & G1~G132 Output) | 1 | 1 | 128RGB x 160 (S7~S390 & G2~G161 output) | | | | |
| | | GM1 | | GM0 | Selection of panel resolution | | | | | | | | | | | | | | |
| | | 0 | | 0 | 132RGB x 162 (S1~S396 & G1~G162 output) | | | | | | | | | | | | | | |
| 0 | 1 | 132RGB x 132 (S1~S396 & G1~G132 Output) | | | | | | | | | | | | | | | | | |
| 1 | 1 | 128RGB x 160 (S7~S390 & G2~G161 output) | | | | | | | | | | | | | | | | | |
| | | | | | | | | | | | | | | | | | | | |
| | | | | | | | | | | | | | | | | | | | |
| SRGB | I | -RGB Direction Select H/W Pin for Color Filter Setting. | VDDI/DGND | | | | | | | | | | | | | | | | |
| | | <table border="1"> <tr> <td>SRGB</td> <td>RGB Arrangement</td> </tr> <tr> <td>0</td> <td>S1, S2, S3 Filter Order = 'R', 'G', 'B'</td> </tr> <tr> <td>1</td> <td>S1, S2, S3 Filter Order = 'B', 'G', 'R'</td> </tr> </table> | | SRGB | RGB Arrangement | 0 | S1, S2, S3 Filter Order = 'R', 'G', 'B' | 1 | S1, S2, S3 Filter Order = 'B', 'G', 'R' | | | | | | | | | | |
| | | SRGB | | RGB Arrangement | | | | | | | | | | | | | | | |
| 0 | S1, S2, S3 Filter Order = 'R', 'G', 'B' | | | | | | | | | | | | | | | | | | |
| 1 | S1, S2, S3 Filter Order = 'B', 'G', 'R' | | | | | | | | | | | | | | | | | | |
| | | | | | | | | | | | | | | | | | | | |
| SMX | I | -Module Source Output Direction H/W Selection Pin. | VDDI/DGND | | | | | | | | | | | | | | | | |
| | | <table border="1"> <tr> <td>SMX</td> <td colspan="3">Scanning direction of source output</td> </tr> <tr> <td></td> <td>GM= '00'</td> <td>GM= '01'</td> <td>GM= '11'</td> </tr> <tr> <td>0</td> <td>S1 -> S396</td> <td>S1 -> S396</td> <td>S7 -> S390</td> </tr> <tr> <td>1</td> <td>S396 -> S1</td> <td>S396 -> S1</td> <td>S390 -> S7</td> </tr> </table> | | SMX | Scanning direction of source output | | | | GM= '00' | GM= '01' | GM= '11' | 0 | S1 -> S396 | S1 -> S396 | S7 -> S390 | 1 | S396 -> S1 | S396 -> S1 | S390 -> S7 |
| | | SMX | | Scanning direction of source output | | | | | | | | | | | | | | | |
| | | | | GM= '00' | GM= '01' | GM= '11' | | | | | | | | | | | | | |
| 0 | S1 -> S396 | S1 -> S396 | S7 -> S390 | | | | | | | | | | | | | | | | |
| 1 | S396 -> S1 | S396 -> S1 | S390 -> S7 | | | | | | | | | | | | | | | | |
| | | | | | | | | | | | | | | | | | | | |
| | | | | | | | | | | | | | | | | | | | |
| SMY | I | -Module Gate Output Direction H/W Selection Pin. | VDDI/DGND | | | | | | | | | | | | | | | | |
| | | <table border="1"> <tr> <td>SMY</td> <td colspan="3">Scanning direction of gate output</td> </tr> <tr> <td></td> <td>GM= '00'</td> <td>GM= '01'</td> <td>GM= '11'</td> </tr> <tr> <td>0</td> <td>G1 -> G162</td> <td>G1 -> G132</td> <td>G2 -> G161</td> </tr> <tr> <td>1</td> <td>G162 -> G1</td> <td>G132 -> G1</td> <td>G161 -> G2</td> </tr> </table> | | SMY | Scanning direction of gate output | | | | GM= '00' | GM= '01' | GM= '11' | 0 | G1 -> G162 | G1 -> G132 | G2 -> G161 | 1 | G162 -> G1 | G132 -> G1 | G161 -> G2 |
| | | SMY | | Scanning direction of gate output | | | | | | | | | | | | | | | |
| | | | | GM= '00' | GM= '01' | GM= '11' | | | | | | | | | | | | | |
| 0 | G1 -> G162 | G1 -> G132 | G2 -> G161 | | | | | | | | | | | | | | | | |
| 1 | G162 -> G1 | G132 -> G1 | G161 -> G2 | | | | | | | | | | | | | | | | |
| | | | | | | | | | | | | | | | | | | | |
| | | | | | | | | | | | | | | | | | | | |
| LCM | I | -Liquid Crystal (LC) Type Selection Pins. | VDDI/DGND | | | | | | | | | | | | | | | | |
| | | <table border="1"> <tr> <td>LCM</td> <td>Selection of LC Type</td> </tr> <tr> <td>0</td> <td>Normally White LC Type</td> </tr> <tr> <td>1</td> <td>Normally Black LC Type</td> </tr> </table> | | LCM | Selection of LC Type | 0 | Normally White LC Type | 1 | Normally Black LC Type | | | | | | | | | | |
| | | LCM | | Selection of LC Type | | | | | | | | | | | | | | | |
| 0 | Normally White LC Type | | | | | | | | | | | | | | | | | | |
| 1 | Normally Black LC Type | | | | | | | | | | | | | | | | | | |
| | | | | | | | | | | | | | | | | | | | |
| GS | I | -Gamma Curve Selection Pin. | VDDI/DGND | | | | | | | | | | | | | | | | |
| | | <table border="1"> <tr> <td>GS</td> <td>Selection of Gamma Curve</td> </tr> <tr> <td>0</td> <td>GC0=1.0, GC1=2.5, GC2=2.2, GC3=1.8</td> </tr> <tr> <td>1</td> <td>GC0=2.2, GC1=1.8, GC2=2.5, GC3=1.0</td> </tr> </table> | | GS | Selection of Gamma Curve | 0 | GC0=1.0, GC1=2.5, GC2=2.2, GC3=1.8 | 1 | GC0=2.2, GC1=1.8, GC2=2.5, GC3=1.0 | | | | | | | | | | |
| | | GS | | Selection of Gamma Curve | | | | | | | | | | | | | | | |
| 0 | GC0=1.0, GC1=2.5, GC2=2.2, GC3=1.8 | | | | | | | | | | | | | | | | | | |
| 1 | GC0=2.2, GC1=1.8, GC2=2.5, GC3=1.0 | | | | | | | | | | | | | | | | | | |
| | | | | | | | | | | | | | | | | | | | |

| | | | | | | | | | |
|-------|--------------------------|--|-------|--------------------------|---|---------------------|---|---------------------|------|
| VPP | I | When writing NVM, it needs external power supply voltage (7.5V). | | | | | | | |
| TESEL | I | <p>Input pin to select horizontal line number in TE signal. This pin is internally pull low.</p> <table border="1"> <tr> <td>TESEL</td> <td>Selection of gamma curve</td> </tr> <tr> <td>0</td> <td>TE output 162 lines</td> </tr> <tr> <td>1</td> <td>TE output 160 lines</td> </tr> </table> | TESEL | Selection of gamma curve | 0 | TE output 162 lines | 1 | TE output 160 lines | DGND |
| TESEL | Selection of gamma curve | | | | | | | | |
| 0 | TE output 162 lines | | | | | | | | |
| 1 | TE output 160 lines | | | | | | | | |

6.4 Driver Output pins

| Name | I/O | Description | Connect Pin |
|------------|-----|--|------------------|
| S1 to S396 | O | - Source Driver Output Pins. | - |
| G1 to G162 | O | - Gate Driver Output Pins. | - |
| AVDD | O | - Power Pin for Analog Circuits. | - |
| AVCL | O | - A power Supply Pin for Generating GVCL. | - |
| VGH | O | - Power Output Pin for Gate Driver | - |
| VGL | O | - Power Output (Negative) Pin for Gate Driver | - |
| GVDD | O | - A power Output of Grayscale Voltage Generator. - When internal GVDD generator is not used, connect an external power supply (AVDD-0.5V) to this pin. | - |
| GVCL | O | - A power Output (Negative) of Grayscale Voltage Generator. - When internal GVCL generator is not used, connect an external power supply (AVCL+0.5V) to this pin. | - |
| VCOM | O | - A Power Supply for the TFT-LCD Common Electrode. | Common Electrode |
| VCC | O | - Monitoring Pin of Internal Digital Reference Voltage. - Please Open These Pins. | |
| VCL | O | - A power output of VCOM voltage (Negative) generator. | |
| VDDIO | O | - VDDI Voltage Output Level for Monitoring. | - |
| DGND0 | O | - DGND Voltage Output Level for Monitoring. | - |

6.5 Test Pins

| Name | I/O | Description | Connect Pin |
|--|-----|--|-------------|
| TEST2P TEST1P | I | -These test pins for driver vender test used. -Please connect these pins to DGND. | DGND |
| TESTOP[8] TESTOP[7] TESTOP[6] TESTOP[5] TESTOP[4] TESTOP[3] TESTOP[2] TESTOP[1] | O | -These test pins for driver vender test used. -Please open these pins. | Open |
| DummyR | - | -These pins are dummy (have no function inside). -Pad128 DummyR internal short to pad 129 DummyR. | Open |
| Dummy | - | -These pins are dummy (have no function inside). -Can allow signal traces pass through these pads on TFT glass. -Please open these pins. | Open |

7 DRIVER ELECTRICAL CHARACTERISTICS

7.1 Absolute Operation Range

| Item | Symbol | Rating | Unit |
|-----------------------------|---------|-------------------|------|
| Supply Voltage | VDD | - 0.3 ~ +4.8 | V |
| Supply Voltage (Logic) | VDDI | - 0.3 ~ +4.6 | V |
| Supply Voltage (Digital) | VCC | -0.3 ~ +1.95 | V |
| Driver Supply Voltage | VGH-VGL | -0.3 ~ +30.0 | V |
| Logic Input Voltage Range | VIN | -0.3 ~ VDDI + 0.3 | V |
| Logic Input Voltage Range | VO | -0.3 ~ VDDI + 0.3 | V |
| Operating Temperature Range | TOPR | -30 ~ +85 | °C |
| Storage Temperature Range | TSTG | -40 ~ +125 | °C |

Table 1 Absolute Operation Range

Note: If one of the above items is exceeded its maximum limitation momentarily, the quality of the product may be degraded. Absolute maximum limitation, therefore, specify the values exceeding which the product may be physically damaged. Be sure to use the product within the recommend range.

7.2 DC Characteristic

| Parameter | Symbol | Condition | Specification | | | Unit | Related Pins |
|-----------------------------|---------|--------------------------|---------------|------|---------|------|--------------|
| | | | Min | Typ | Max | | |
| Power & Operation Voltage | | | | | | | |
| System Voltage | VDD | Operating Voltage | 2.5 | 2.75 | 4.8 | V | |
| Interface Operation Voltage | VDDI | I/O Supply Voltage | 1.65 | 1.8 | 3.7 | V | |
| Gate Driver High Voltage | VGH | | 11 | | 16 | V | Note 4 |
| Gate Driver Low Voltage | VGL | | -13 | | -7.5 | V | |
| Gate Driver Supply Voltage | | VGH-VGL | 18.5 | | 29 | V | Note 4 |
| Input / Output | | | | | | | |
| Logic-High Input Voltage | VIH | | 0.7VDDI | | VDDI | V | Note 1 |
| Logic-Low Input Voltage | VIL | | VSS | | 0.3VDDI | V | Note 1 |
| Logic-High Output Voltage | VOH | IOH = -1.0mA | 0.8VDDI | | VDDI | V | Note 1 |
| Logic-Low Output Voltage | VOL | IOL = +1.0mA | VSS | | 0.2VDDI | V | Note 1 |
| Logic-High Input Current | IIH | VIN = VDDI | | | 1 | uA | Note 1 |
| Logic-Low Input Current | IIL | VIN = VSS | -1 | | | uA | Note 1 |
| Input Leakage Current | IIL | IOH = -1.0mA | -0.1 | | +0.1 | uA | Note 1 |
| VCOM Voltage | | | | | | | |
| VCOM Amplitude | VCOM | | -2 | | -0.425 | V | |
| Source driver | | | | | | | |
| Source Output Range | Vsout | | 0.1 | | GVDD | V | |
| Gamma Reference Voltage | GVDD | | 3.15 | | 4.7 | V | |
| Source Output Settling Time | Tr | Below with 99% precision | | | 20 | us | Note 2 |
| Output Offset Voltage | Voffset | | | | 35 | mV | Note 3 |

Table 2 DC Characteristic

Notes:

1. TA= -30 to 85°C.
2. Source channel loading= 2KΩ+12pF/channel, Gate channel loading=5KΩ+40pF/channel.
3. The Max. value is between measured point of source output and gamma setting value.
4. VGH setting condition is AVDD=4.7V, the Max and Min VGH voltage depend on AVDD setting, VGH-VGL can not large than 30V.

7.3 Power Consumption

Ta=25°C, Frame rate = 60Hz, Bare die, the registers setting are IC default setting.

| Operation Mode | Image | Current Consumption | | | |
|--------------------------------|--------|---------------------|-------------|--------------|-------------|
| | | Typical | | Maximum | |
| | | IDD1 (mA) | IDD (mA) | IDD1 (mA) | IDD (mA) |
| Normal Mode | Note 1 | 0.01 | 0.9 | 0.02 | 2 |
| | Note 2 | 0.01 | 0.9 | 0.02 | 2 |
| Partial + Idle Mode (40 lines) | Note 1 | 0.01 | 0.8 | 0.02 | 2 |
| | Note 2 | 0.01 | 0.8 | 0.02 | 2 |
| Sleep-In Mode | N/A | 0.005 | 0.015 | 0.01 | 0.03 |

Table 3 Power Consumption

Notes:

1. All pixels black.
2. All pixels white.
3. The Current Consumption is DC characteristics of ST7735S.
4. Typical: VDD1=1.8V, VDD=2.75V; Maximum: VDD1=1.65 to 3.7V, VDD=2.5 to 4.8V

8 Timing chart

8.1 Parallel Interface Characteristics: 18, 16, 9 or 8-bit Bus (8080 Series MCU Interface)

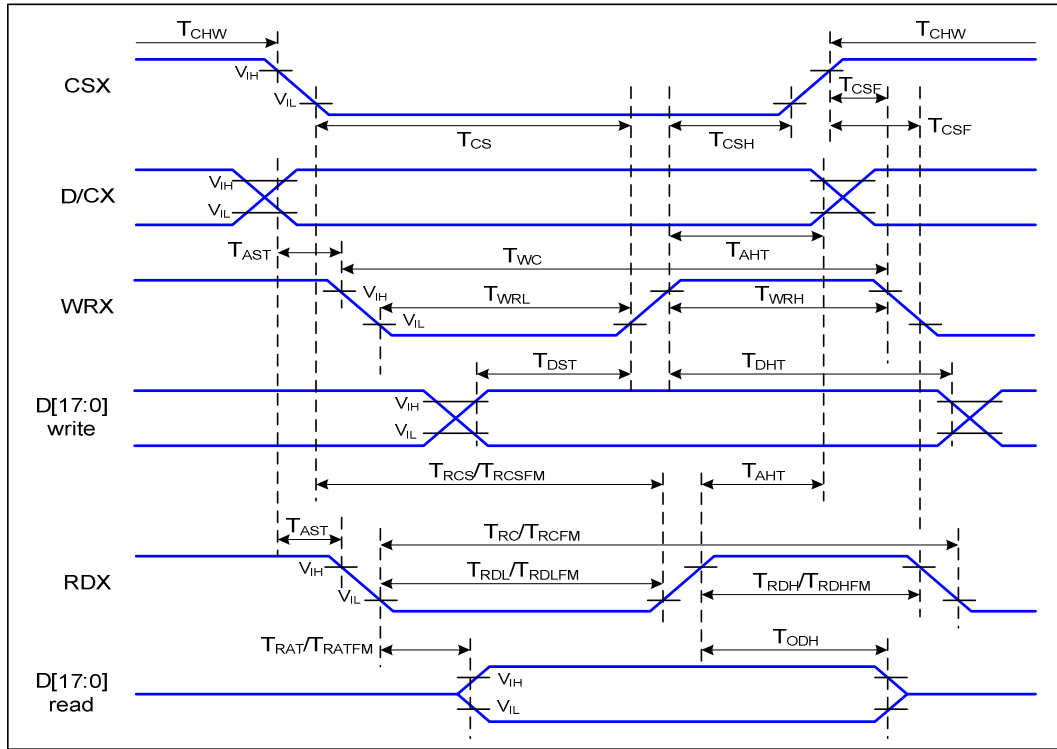

Figure 1 Parallel Interface Timing Characteristics (8080 Series MCU Interface)

Ta=25 °C, VDDI=1.65~3.7V, VDD=2.5~4.8V

| Signal | Symbol | Parameter | Min | Max | Unit | Description |
|----------|--------|------------------------------------|-----|-----|------|-------------------|
| D/CX | TAST | Address Setup Ttime | 0 | | ns | - |
| | TAHT | Address Hold Time (Write/Read) | 10 | | ns | |
| CSX | TCHW | Chip Select "H" Pulse Width | 0 | | ns | - |
| | TCS | Chip Select Setup Time (Write) | 15 | | ns | |
| | TRCS | Chip Select Setup Time (Read ID) | 45 | | ns | |
| | TRCSFM | Chip Select Setup time (Read FM) | 355 | | ns | |
| | TCSF | Chip Select Wait Time (Write/Read) | 10 | | ns | |
| | TCSH | Chip Select Hold Time | 10 | | ns | |
| WRX | TWC | Write Cycle | 66 | | ns | |
| | TWRH | Control Pulse "H" Duration | 15 | | ns | |
| | TWRL | Control Pulse "L" Duration | 15 | | ns | |
| RDX (ID) | TRC | Read Cycle (ID) | 160 | | ns | When Read ID Data |
| | TRDH | Control Pulse "H" Duration (ID) | 90 | | ns | |
| | TRDL | Control Pulse "L" Duration (ID) | 45 | | ns | |

| | | | | | | |
|-------------|--------|---------------------------------|-----|-----|----|--------------------------------|
| RDX (FM) | TRCFM | Read Cycle (FM) | 450 | | ns | When Read from Frame Memory |
| | TRDHFM | Control Pulse "H" Duration (FM) | 90 | | ns | |
| | TRDLFM | Control Pulse "L" Duration (FM) | 355 | | ns | |
| D[17:0] | TDST | Data Setup Time | 10 | | ns | For CL=30pF |
| | TDHT | Data Hold Time | 10 | | ns | |
| | TRAT | Read Access Time (ID) | | 40 | ns | |
| | TRATFM | Read Access Time (FM) | | 340 | ns | |
| | TODH | Output Disable Time | 20 | 80 | ns | |

Table 4 8080 Parallel Interface Characteristics

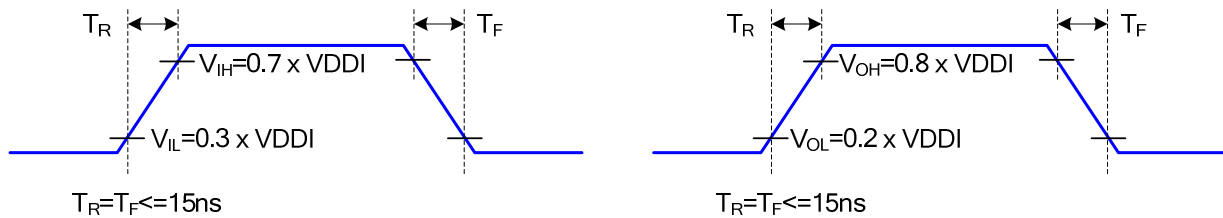

Figure 2 Rising And Falling Timing for Input And Output Signal

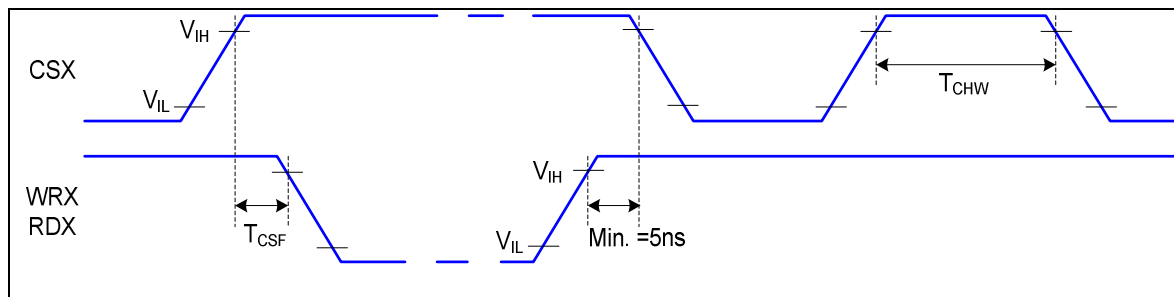

Figure 3 Chip Selection (CSX) Timing

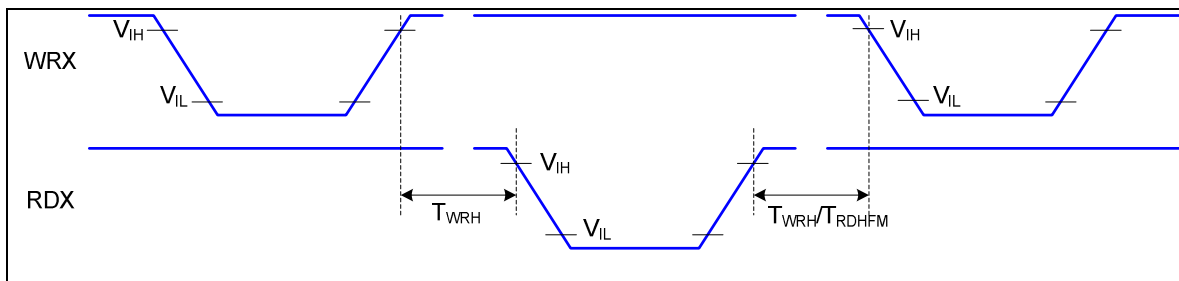

Figure 4 Write-to-Read And Read-to-Write Timing

Note: The rising time and falling time (T_r , T_f) of input signal are specified at 15 ns or less. Logic high and low levels are specified as 30% and 70% of VDDI for Input signals.

8.2 Parallel Interface Characteristics: 18, 16, 9 or 8-bit Bus (6800 Series MCU Interface)

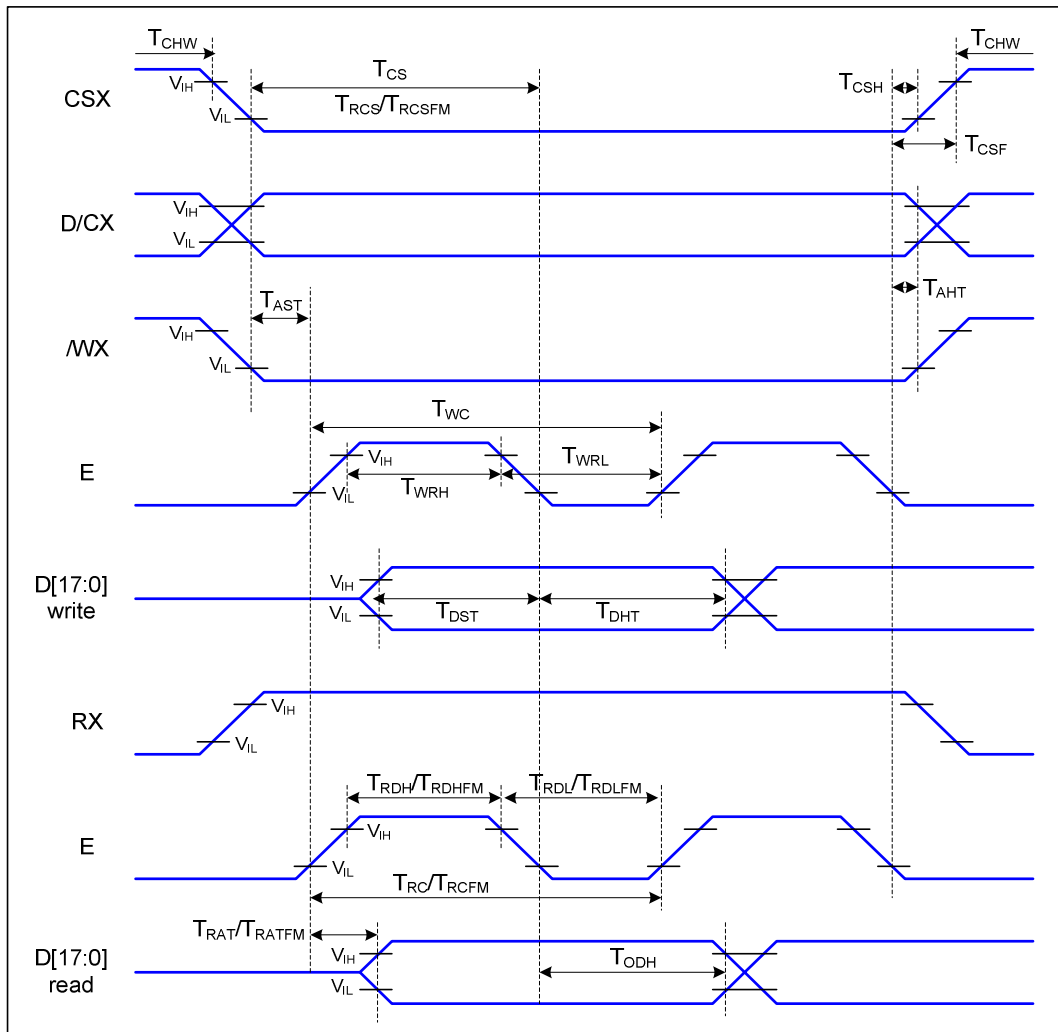

Figure 5 Parallel Interface Timing Characteristics (6800-Series MCU Interface)

Ta=25 °C, VDDI=1.65~3.7V, VDD=2.5~4.8V

| Signal | Symbol | Parameter | Min | Max | Unit | Description |
|--------|--------------------|------------------------------------|-----|-----|------|-------------|
| D/CX | T _{AST} | Address Setup Time | 0 | | ns | - |
| | T _{AHT} | Address Hold Time (Write/Read) | 10 | | ns | |
| CSX | T _{CHW} | Chip Select "H" Pulse Width | 0 | | ns | - |
| | T _{CS} | Chip Select Setup Time (Write) | 15 | | ns | |
| | T _{RCS} | Chip Select Setup Time (Read ID) | 45 | | ns | |
| | T _{RCSFM} | Chip Select Setup Time (Read FM) | 355 | | ns | |
| | T _{CSF} | Chip Select wait Time (Write/Read) | 10 | | ns | |
| | T _{CSH} | Chip Select Hold Time | 10 | | ns | |
| WRX | T _{WC} | Write Cycle | 66 | | ns | - |
| | T _{WRH} | Control Pulse "H" Duration | 15 | | ns | |
| | T _{WRL} | Control Pulse "L" Duration | 15 | | ns | |

| | | | | | | |
|----------|-------------|---------------------------------|---------------------|----|----|-----------------------------|
| RDX (ID) | T_{RC} | Read Cycle (ID) | 160 | | ns | When Read ID Data |
| | T_{RDH} | Control Pulse "H" Duration (ID) | 90 | | ns | |
| | T_{RDL} | Control Pulse "L" Duration (ID) | 45 | | ns | |
| RDX (FM) | T_{RCFM} | Read Cycle (FM) | 450 | | ns | When Read From Frame Memory |
| | T_{RDHFM} | Control Pulse "H" Duration (FM) | 90 | | ns | |
| | T_{RDLFM} | Control Pulse "L" Duration (FM) | 355 | | ns | |
| D[17:0] | T_{DST} | Data Setup Time | 10 | | ns | For Maximum CL=30pF |
| | T_{DHT} | Data Hold Time | 10 | | ns | |
| | | T_{ODH} | Output Disable Time | 20 | 80 | ns |

Table 5 6800 Parallel Interface Characteristics

Note: The rising time and falling time (T_r , T_f) of input signal are specified at 15 ns or less. Logic high and low levels are specified as 30% and 70% of VDDI for Input signals

8.3 Serial Interface Characteristics (3-line Serial)

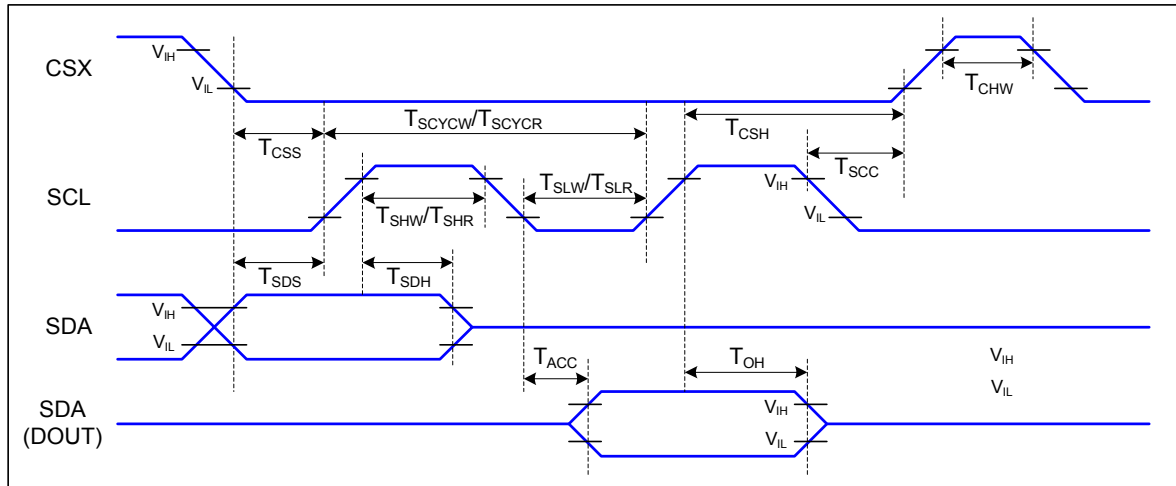

Figure 6 3-line Serial Interface Timing

T_a=25 °C, VDDI=1.65~3.7V, VDD=2.5~4.8V

| Signal | Symbol | Parameter | Min | Max | Unit | Description |
|------------------------|--------|--------------------------------|-----|-----|------|---|
| CSX | TCSS | Chip Select Setup Time (Write) | 15 | | ns | |
| | TCSH | Chip Select Hold Time (Write) | 15 | | ns | |
| | TCSS | Chip Select Setup Time (Read) | 60 | | ns | |
| | TSCC | Chip Select Hold Time (Read) | 65 | | ns | |
| | TCHW | Chip Select "H" pulse width | 40 | | ns | |
| SCL | TSCYCW | Serial Clock Cycle (Write) | 66 | | ns | |
| | TSHW | SCL "H" Pulse Width (Write) | 15 | | ns | |
| | TSLW | SCL "L" Pulse Width (Write) | 15 | | ns | |
| | TSCYCR | Serial Clock Cycle (Read) | 150 | | ns | |
| | TSHR | SCL "H" Pulse Width (Read) | 60 | | ns | |
| | TSLR | SCL "L" Pulse Width (Read) | 60 | | ns | |
| SDA (DIN) (DOUT) | TSDS | Data Setup Time | 10 | | ns | For Maximum CL=30pF For Minimum CL=8pF |
| | TSDH | Data Hold Time | 10 | | ns | |
| | TACC | Access Time | 10 | 50 | ns | |
| | TOH | Output Disable Time | 15 | 50 | ns | |

Table 6 3-line Serial Interface Characteristics

Note : The rising time and falling time (T_r, T_f) of input signal are specified at 15 ns or less. Logic high and low levels are specified as 30% and 70% of VDDI for Input signals.

8.4 Serial Interface Characteristics (4-line Serial)

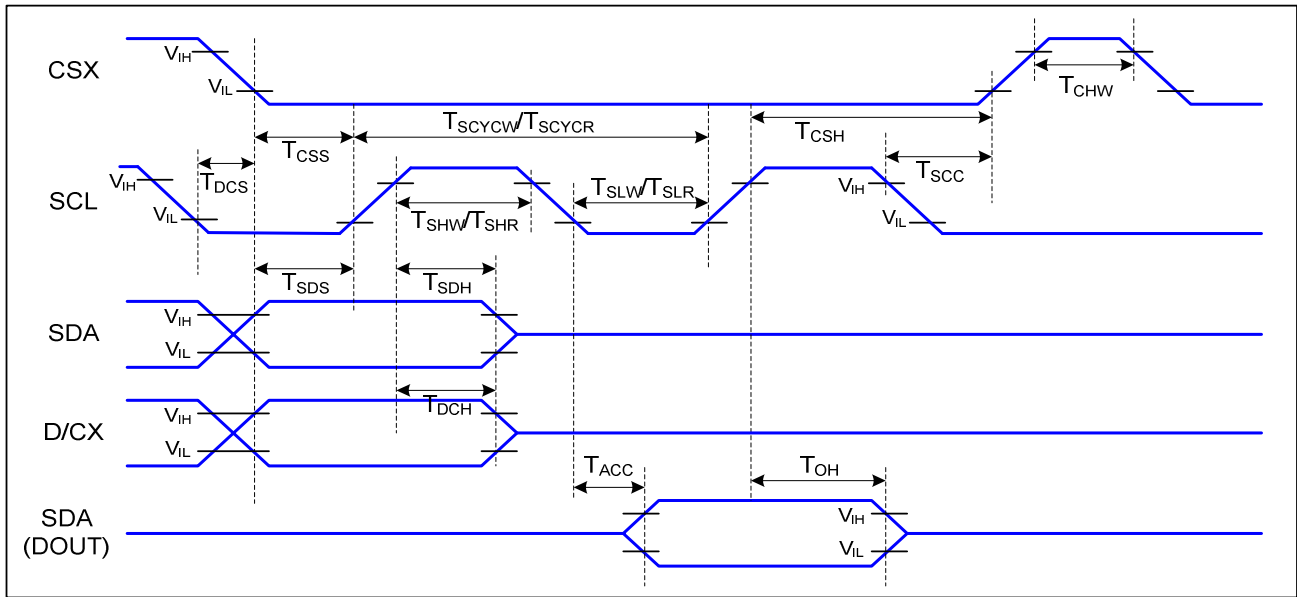

Figure 7 4-line Serial Interface Timing

T_a=25 °C, V_{DDI}=1.65~3.7V, V_{DD}=2.5~4.8V

| Signal | Symbol | Parameter | MIN | MAX | Unit | Description |
|------------------|--------|--------------------------------|-----|-----|------|---|
| CSX | TCSS | Chip Select Setup Time (Write) | 45 | | ns | |
| | TCSH | Chip Select Hold Time (Write) | 45 | | ns | |
| | TCSS | Chip Select Setup Time (Read) | 60 | | ns | |
| | TSCC | Chip Select Hold Time (Read) | 65 | | ns | |
| | TCHW | Chip Select "H" Pulse Width | 40 | | ns | |
| SCL | TSCYCW | Serial Clock Cycle (Write) | 66 | | ns | -Write Command & Data Ram |
| | TSHW | SCL "H" Pulse Width (Write) | 15 | | ns | |
| | TSLW | SCL "L" Pulse Width (Write) | 15 | | ns | |
| | TSCYCR | Serial Clock Cycle (Read) | 150 | | ns | -Read Command & Data Ram |
| | TSHR | SCL "H" Pulse Width (Read) | 60 | | ns | |
| | TSLR | SCL "L" Pulse Width (Read) | 60 | | ns | |
| D/CX | TDCS | D/CX Setup Time | 10 | | ns | |
| | TDCH | D/CX Hold Time | 10 | | ns | |
| SDA (DIN) (DOUT) | TSDS | Data Setup Time | 10 | | ns | For Maximum CL=30pF For Minimum CL=8pF |
| | TSDH | Data Hold Time | 10 | | ns | |
| | TACC | Access Time | 10 | 50 | ns | |
| | TOH | Output Disable Time | 15 | 50 | ns | |

Table 7 4-line Serial Interface Characteristics

Note : The rising time and falling time (Tr, Tf) of input signal are specified at 15 ns or less. Logic high and low levels are specified as 30% and 70% of V_{DDI} for Input signals.

9 Function Description

9.1 Interface Type Selection

The selection of given interfaces are done by setting IM2, IM1, and IM0 pins as shown in following table.

| P68 | IM2 | IM1 | IM0 | Interface | Read Back Selection |
|-----|-----|-----|-----|--------------------------|--|
| - | 0 | - | - | 3-line Serial Interface | Via the Read Instruction |
| 0 | 1 | 0 | 0 | 8080 MCU 8-bit Parallel | RDX Strobe (8-bit Read Data and 8-bit Read Parameter) |
| 0 | 1 | 0 | 1 | 8080 MCU 16-bit Parallel | RDX Strobe (16-bit Read Data and 8-bit Read Parameter) |
| 0 | 1 | 1 | 0 | 8080 MCU 9-bit Parallel | RDX Strobe (9-bit Read Data and 8-bit Read Parameter) |
| 0 | 1 | 1 | 1 | 8080 MCU 18-bit Parallel | RDX Strobe (18-bit Read Data and 8-bit Read Parameter) |
| - | 0 | - | - | 3-line Serial Interface | Via the Read Instruction |
| 1 | 1 | 0 | 0 | 6800 MCU 8-bit Parallel | E Strobe (8-bit Read Data and 8-bit Read Parameter) |
| 1 | 1 | 0 | 1 | 6800 MCU 16-bit Parallel | E Strobe (16-bit Read Data and 8-bit Read Parameter) |
| 1 | 1 | 1 | 0 | 6800 MCU 9-bit Parallel | E Strobe (9-bit Read Data and 8-bit Read Parameter) |
| 1 | 1 | 1 | 1 | 6800 MCU 18-bit Parallel | E Strobe (18-bit Read Data and 8-bit Read Parameter) |

Table 8 Interface Type Selection

| P68 | IM2 | IM1 | IM0 | Interface | RDX | WRX | D/CX | Read back selection |
|-----|-----|-----|-----|-------------------------|-------|-------|------|---------------------------------------|
| - | 0 | - | - | 3-line Serial Interface | Note1 | Note1 | SCL | D[17:1]: Unused, D0: SDA |
| 0 | 1 | 0 | 0 | 8080 8-bit Parallel | RDX | WRX | D/CX | D[17:8]: Unused, D7-D0: 8-bit Data |
| 0 | 1 | 0 | 1 | 8080 16-bit Parallel | RDX | WRX | D/CX | D[17:16]: Unused, D15-D0: 16-bit Data |
| 0 | 1 | 1 | 0 | 8080 9-bit Parallel | RDX | WRX | D/CX | D[17:9]: Unused, D8-D0: 9-bit Data |
| 0 | 1 | 1 | 1 | 8080 18-bit Parallel | RDX | WRX | D/CX | D17-D0: 18-bit Data |
| - | 0 | - | - | 3-line Serial Interface | Note1 | D/CX | SCL | D[17:1]: Unused, D0: SDA |
| 1 | 1 | 0 | 0 | 6800 8-bit Parallel | E | WRX | RS | D[17:8]: Unused, D7-D0: 8-bit Data |
| 1 | 1 | 0 | 1 | 6800 16-bit Parallel | E | WRX | RS | D[17:16]: Unused, D15-D0: 16-bit Data |
| 1 | 1 | 1 | 0 | 6800 9-bit Parallel | E | WRX | RS | D[17:9]: Unused, D8-D0: 9-bit Data |
| 1 | 1 | 1 | 1 | 6800 18-bit Parallel | E | WRX | RS | D17-D0: 18-bit Data |

Table 9 Pin Connection According to Various MCU Interface

Note: Unused pins can be open, or connected to DGND or VDDI.

9.2 8080-series MCU Parallel Interface (P68 = '0')

The MCU can use one of following interfaces: 11-lines with 8-data parallel interface, 12-lines with 9-data parallel interface, 19-line with 16-data parallel interface or 21-lines with 18-data parallel interface. The chip-select CSX (active low) enables/disables the parallel interface. RESX (active low) is an external reset signal. WRX is the parallel data write enable, RDX is the parallel data read enable and D[17:0] is parallel data bus.

The LCD driver reads the data at the rising edge of WRX signal. The D/CX is the data/command flag. When D/CX='1', D[17:0] bits is either display data or command parameter. When D/C='0', D[17:0] bits is command. The interface functions of 8080-series parallel interface are given in following table..

| IM2 | IM1 | IM0 | Interface | D/CX | RDX | WRX | Read Back Selection |
|-----|-----|-----|-----------------|------|-----|-----|--|
| 1 | 0 | 0 | 8-bit Parallel | 0 | 1 | ↑ | Write 8-bit Command (D7 to D0) |
| | | | | 1 | 1 | ↑ | Write 8-bit Display Data or 8-bit Parameter (D7 to D0) |
| | | | | 1 | ↑ | 1 | Read 8-bit Display Data (D7 to D0) |
| | | | | 1 | ↑ | 1 | Read 8-bit Parameter or Status (D7 to D0) |
| 1 | 0 | 1 | 16-bit Parallel | 0 | 1 | ↑ | Write 8-bit Command (D7 to D0) |
| | | | | 1 | 1 | ↑ | Write 16-bit Display Data or 8-bit Parameter (D15 to D0) |
| | | | | 1 | ↑ | 1 | Read 16-bit Display Data (D15 to D0) |
| | | | | 1 | ↑ | 1 | Read 8-bit Parameter or Status (D7 to D0) |
| 1 | 1 | 0 | 9-bit Parallel | 0 | 1 | ↑ | Write 8-bit Command (D7 to D0) |
| | | | | 1 | 1 | ↑ | Write 9-bit Display Data or 8-bit Parameter (D8 to D0) |
| | | | | 1 | ↑ | 1 | Read 9-bit Display Data (D8 to D0) |
| | | | | 1 | ↑ | 1 | Read 8-bit Parameter or Status (D7 to D0) |
| 1 | 1 | 1 | 18-bit Parallel | 0 | 1 | ↑ | Write 8-bit Command (D7 to D0) |
| | | | | 1 | 1 | ↑ | Write 18-bit Display Data or 8-bit Parameter (D17 to D0) |
| | | | | 1 | ↑ | 1 | Read 18-bit Display Data (D17 to D0) |
| | | | | 1 | ↑ | 1 | Read 8-bit Parameter or Status (D7 to D0) |

Table 10 The Function of 8080-series Parallel Interface

Note: applied for command code: DAh, DBh, DCh, 04h, 09h, 0Ah, 0Bh, 0Ch, 0Dh, 0Eh, 0Fh

9.2.1 Write Cycle Sequence

The write cycle means that the host writes information (command or/and data) to the display via the interface. Each write cycle (WRX high-low-high sequence) consists of 3 control signals (D/CX, RDX, WRX) and data signals (D[17:0]). D/CX bit is a control signal, which tells if the data is a command or a data. The data signals are the command if the control signal is low (=‘0’) and vice versa it is data (=‘1’).

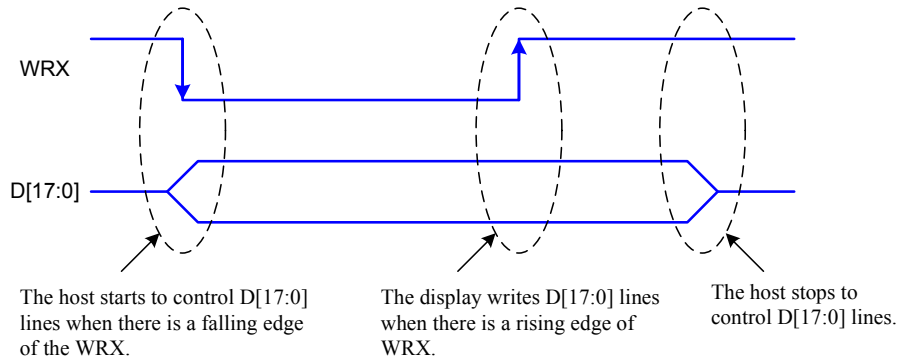

Figure 8 8080-series WRX Protocol

Note: WRX is an unsynchronized signal (It can be stopped).

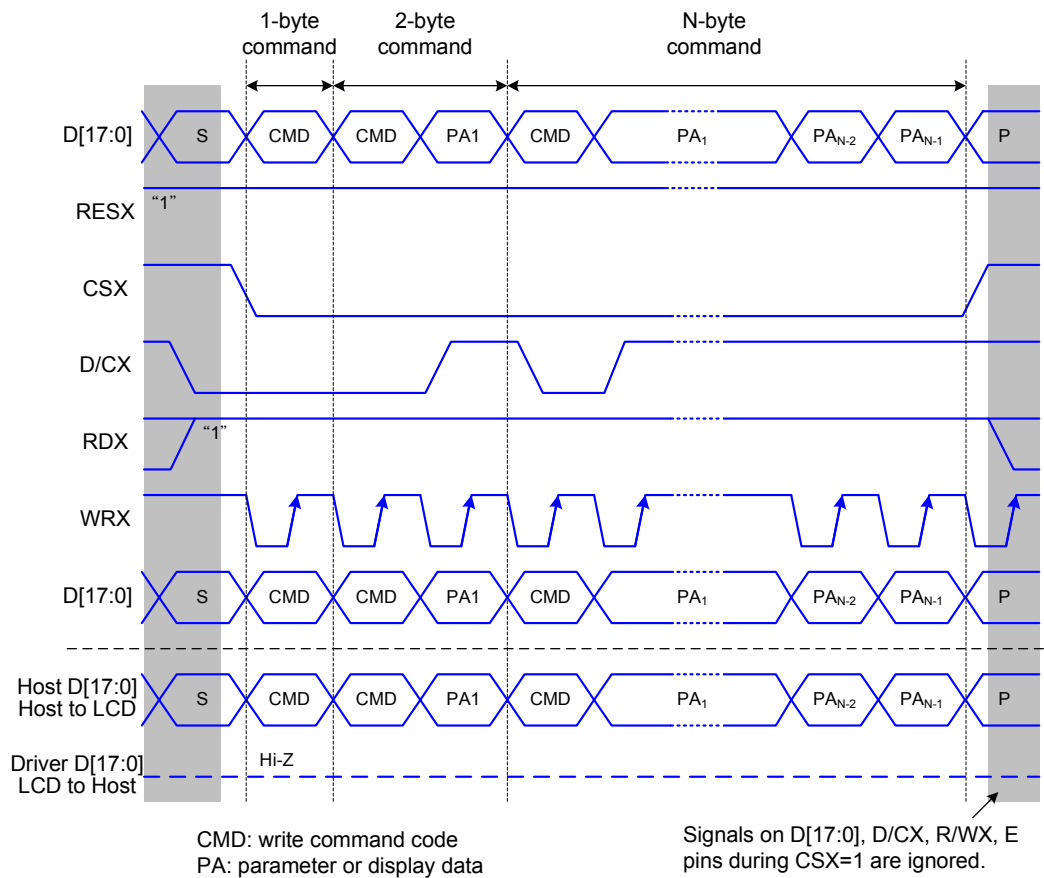

Figure 9 8080-series Parallel Bus Protocol, Write to Register or Display RAM

9.2.2 Read Cycle Sequence

The read cycle (RDX high-low-high sequence) means that the host reads information from LCD driver via interface. The driver sends data (D[17:0]) to the host when there is a falling edge of RDX and the host reads data when there is a rising edge of RDX.

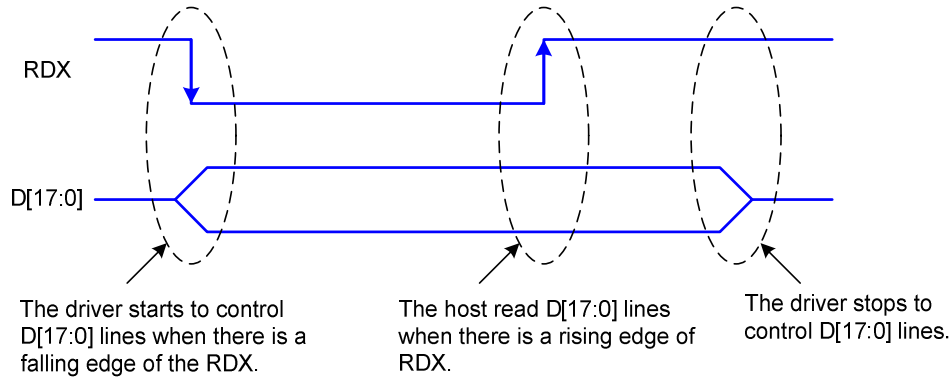

Figure 10 8080-series RDX Protocol

Note: RDX is an unsynchronized signal (It can be stopped).

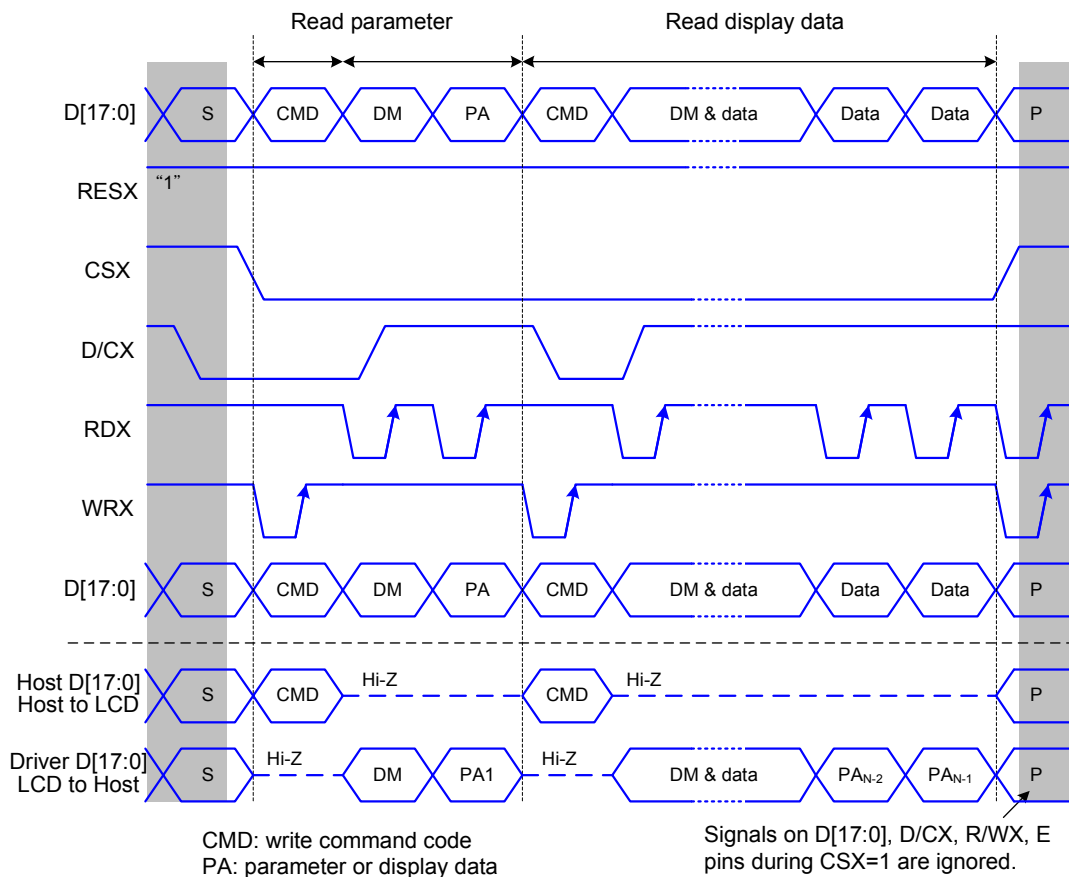

Figure 11 8080-series Parallel Bus Protocol, Read Data from Register or Display RAM

9.3 6800-series MCU Parallel Interface (P68 = '1')

The MCU uses one of following interface: 11-lines with 8-data parallel interface, 12-lines with 9-data parallel interface, 19-lines with 16-data parallel interface, or 21-lines with 18-data parallel interface. The chip-select CSX(active low) enables and disables the parallel interface. RESX (active low) is an external reset signal. The R/WX is the Read/Write flag and D[17:0] is parallel data bus.

The LCD driver reads the data at the falling edge of E signal when R/WX= '1' and Writes the data at the falling of the E signal when R/WX='0'. The D/CX is the data/command flag. When D/CX='1', D[17:0] bits are display RAM data or command parameters. When D/C= '0', D[17:0] bits are commands.

The 6800-series bi-directional interface can be used for communication between the micro controller and LCD driver. The selection of this interface is done when P68 pin is high state (VDDI). Interface bus width can be selected with IM2, IM1 and IM0.The interface functions of 6800-series parallel interface are given in Table11.

| P68 | IM2 | IM1 | IM0 | Interface | D/CX | R/WX | E | Function |
|-----|-----|-----|-----|-----------------|------|------|---|--|
| 1 | 1 | 0 | 0 | 8-bit Parallel | 0 | 0 | ↓ | Write 8-bit Command (D7 to D0) |
| | | | | | 1 | 0 | ↓ | Write 8-bit Display Data or 8-bit Parameter (D7 to D0) |
| | | | | | 1 | 1 | ↓ | Read 8-bit Display Data (D7 to D0) |
| | | | | | 1 | 1 | ↓ | Read 8-bit Parameter or Status (D7 to D0) |
| 1 | 1 | 0 | 1 | 16-bit Parallel | 0 | 0 | ↓ | Write 8-bit Command (D7 to D0) |
| | | | | | 1 | 0 | ↓ | Write 16-bit Display Data or 8-bit Parameter (D15 to D0) |
| | | | | | 1 | 1 | ↓ | Read 16-bit Display Data (D15 to D0) |
| | | | | | 1 | 1 | ↓ | Read 8-bit Parameter or Status (D7 to D0) |
| 1 | 1 | 1 | 0 | 9-bit Parallel | 0 | 0 | ↓ | Write 8-bit Command (D7 to D0) |
| | | | | | 1 | 0 | ↓ | Write 9-bit Display Data or 8-bit Parameter (D8 to D0) |
| | | | | | 1 | 1 | ↓ | Read 9-bit Display Data (D8 to D0) |
| | | | | | 1 | 1 | ↓ | Read 8-bit Parameter or Status (D7 to D0) |
| 1 | 1 | 1 | 1 | 18-bit Parallel | 0 | 0 | ↓ | Write 8-bit Command (D7 to D0) |
| | | | | | 1 | 0 | ↓ | Write 18-bit Display Data or 8-bit Parameter (D17 to D0) |
| | | | | | 1 | 1 | ↓ | Read 18-bit Display Data (D17 to D0) |
| | | | | | 1 | 1 | ↓ | Read 8-bit Parameter or Status (D7 to D0) |

Table 11 The Function of 6800-series Parallel Interface

Note: applied for command code: DAh, DBh, DCh, 04h, 09h, 0Ah, 0Bh, 0Ch, 0Dh, 0Eh, 0Fh.

9.3.1 Write Cycle Sequence

The write cycle means that the host writes information (command or/and data) to the display via the interface. Each write cycle (E low-high-low sequence) consists of 3 control signals (D/CX, E, R/WX) and data signals (D[17:0]). D/CX bit is a control signal, which tells if the data is a command or a data. The data signals are the command if the control signal is low (=‘0’) and vice versa it is data (=‘1’).

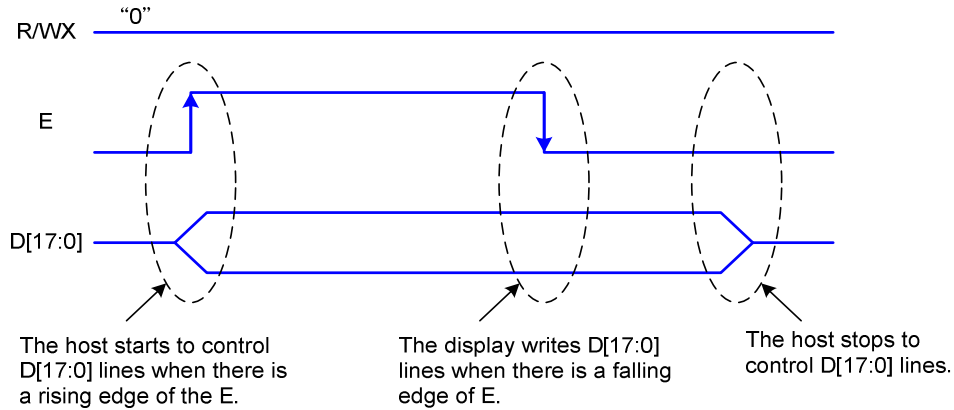

Figure 12 6800-series Write Protocol

Note: E is an unsynchronized signal (It can be stopped)

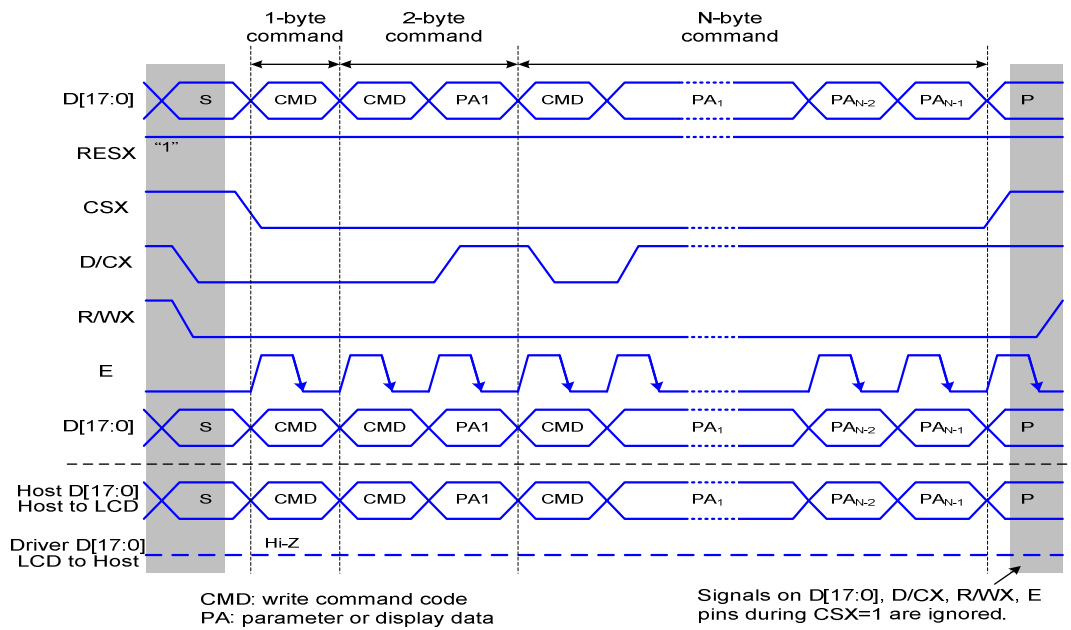

Figure 13 6800-series Parallel Bus Protocol, Write to Register or Display RAM

9.3.2 Read Cycle Sequence

The read cycle (E low-high-low sequence) means that the host reads information from LCD driver via interface. The driver sends data (D[17:0]) to the host when there is a rising edge of E and the host reads data when there is a falling edge of E.

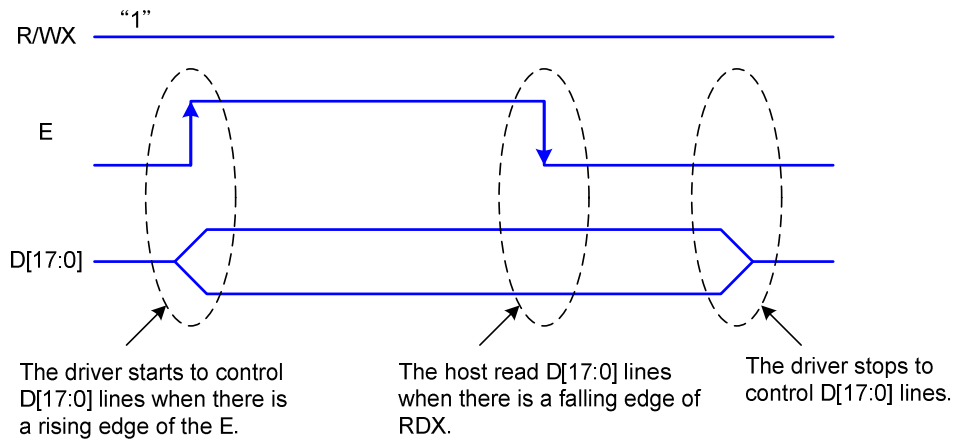

Figure 14 6800-series Read Protocol

Note: E is an unsynchronized signal (It can be stopped)

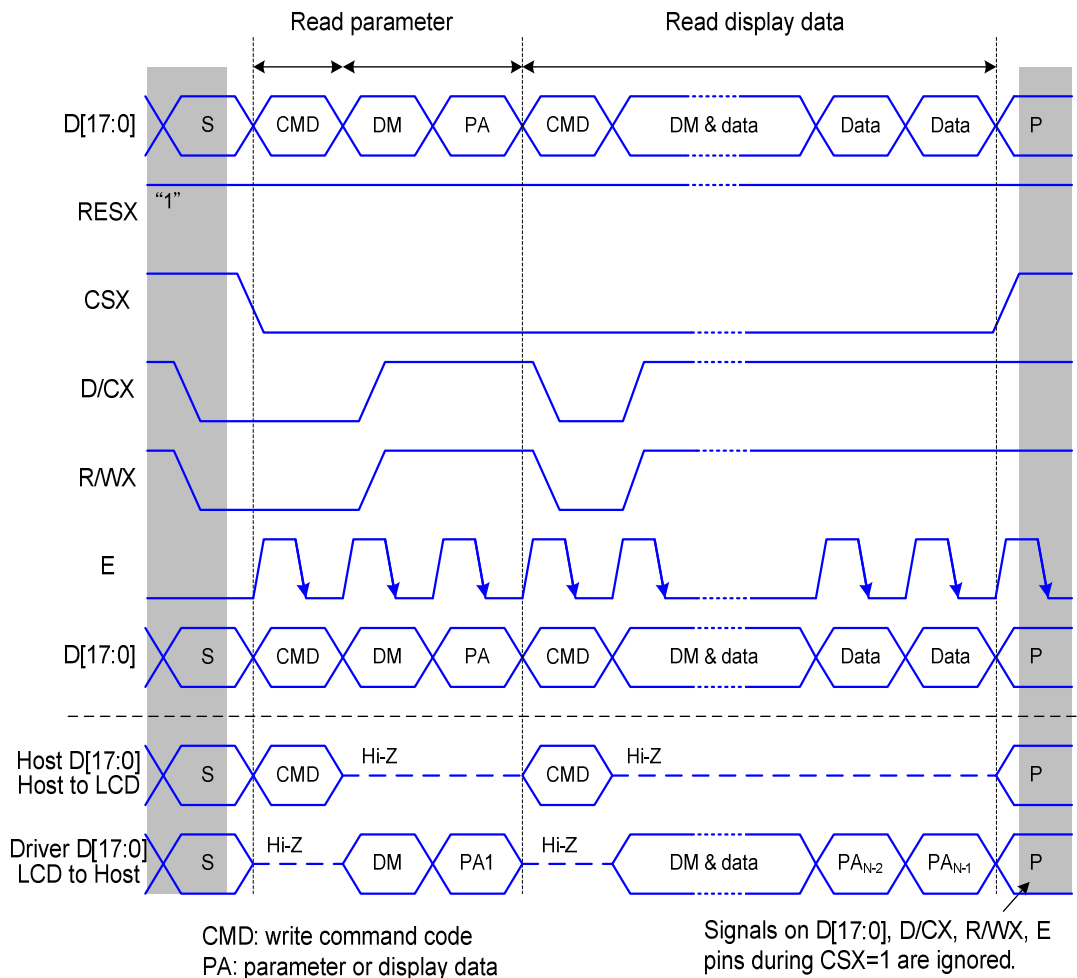

Figure 15 6800-series Parallel Bus Protocol, Read Data form Register or Display RAM

9.4 Serial Interface

The selection of this interface is done by IM2. See the Table 12.

| IM2 | 4WSPI | Interface | Read Back Selection |
|-----|-------|-------------------------|--|
| 0 | 0 | 3-line Serial Interface | Via the Read Instruction (8-bit, 24-bit and 32-bit Read Parameter) |
| 0 | 1 | 4-line Serial Interface | Via the Read Instruction (8-bit, 24-bit and 32-bit Read Parameter) |

Table 12 Selection of Serial Interface

The serial interface is either 3-lines/9-bits or 4-lines/8-bits bi-directional interface for communication between the micro controller and the LCD driver. The 3-lines serial interface use: CSX (chip enable), SCL (serial clock) and SDA (serial data input/output), and the 4-lines serial interface use: CSX (chip enable), D/CX (data/command flag), SCL (serial clock) and SDA (serial data input/output). Serial clock (SCL) is used for interface with MCU only, so it can be stopped when no communication is necessary.

9.4.1 Command Write Mode

The write mode of the interface means the micro controller writes commands and data to the LCD driver. 3-lines serial data packet contains a control bit D/CX and a transmission byte. In 4-lines serial interface, data packet contains just transmission byte and control bit D/CX is transferred by the D/CX pin. If D/CX is “low”, the transmission byte is interpreted as a command byte. If D/CX is “high”, the transmission byte is stored in the display data RAM (memory write command), or command register as parameter.

Any instruction can be sent in any order to the driver. The MSB is transmitted first. The serial interface is initialized when CSX is high. In this state, SCL clock pulse or SDA data have no effect. A falling edge on CSX enables the serial interface and indicates the start of data transmission.

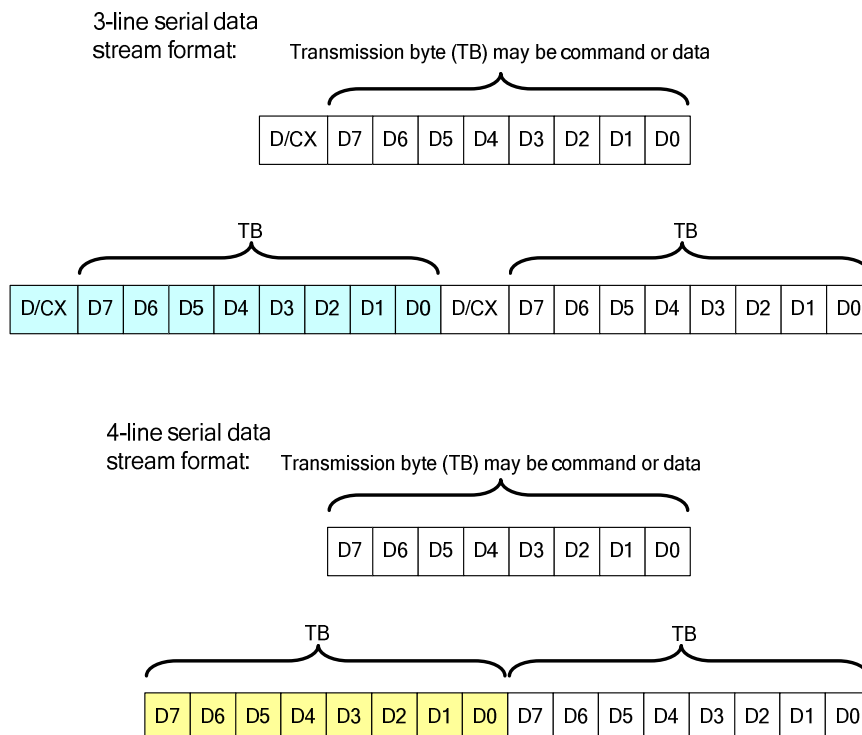

Figure 16 Serial Interface Data Stream Format

When CSX is “high”, SCL clock is ignored. During the high period of CSX the serial interface is initialized. At the falling edge of CSX, SCL can be high or low (see Figure 17). SDA is sampled at the rising edge of SCL. D/CX indicates whether the byte is command (D/CX=’0’) or parameter/RAM data (D/CX=’1’). D/CX is sampled when first rising edge of SCL (3-lines serial interface) or 8th rising edge of SCL (4-lines serial interface). If CSX stays low after the last bit of command/data byte, the serial interface expects the D/CX bit (3-lines serial interface) or D7 (4-lines serial interface) of the next byte at the next rising edge of SCL..

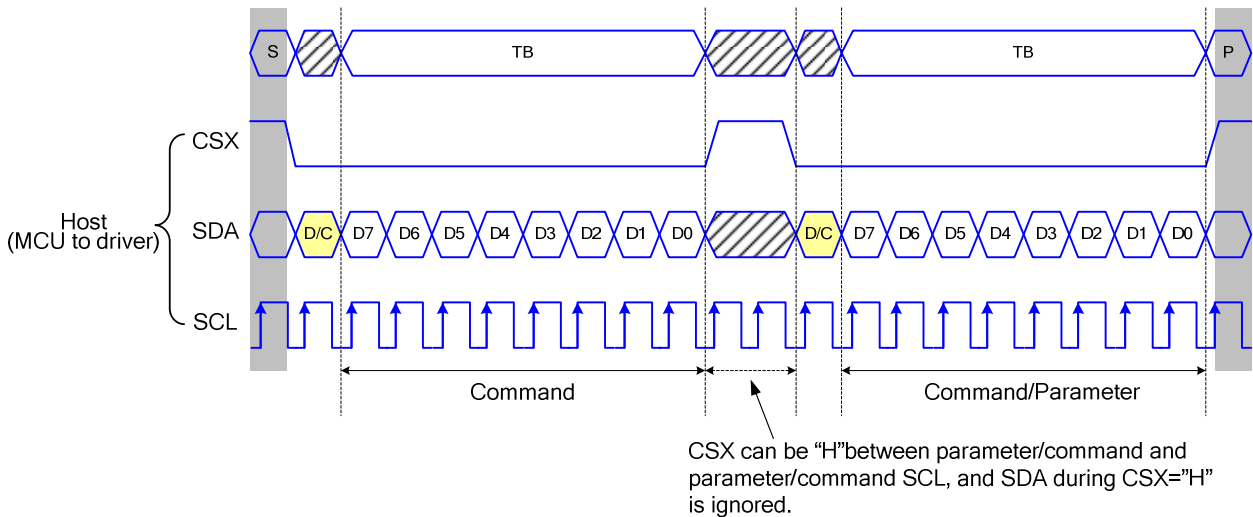

Figure 17 3-line Serial Interface Write Protocol (Write to Register with Control Bit in Transmission)

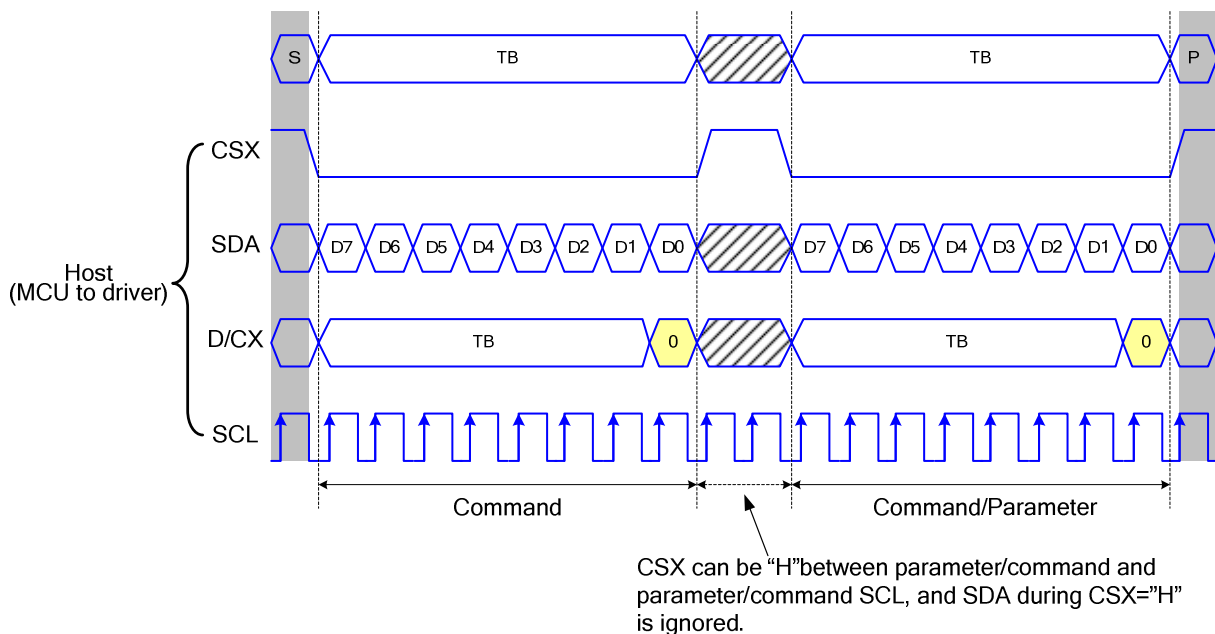

Figure 18 4-line Serial Interface Write Protocol (Write to Register with Control Bit in Transmission)

9.4.2 Read Functions

The read mode of the interface means that the micro controller reads register value from the driver. To achieve read function, the micro controller first has to send a command (read ID or register command) and then the following byte is transmitted in the opposite direction. After that CSX is required to go to high before a new command is send (see the below figure). The driver samples the SDA (input data) at rising edge of SCL, but shifts SDA (output data) at the falling edge of SCL. Thus the micro controller is supported to read at the rising edge of SCL.

After the read status command has been sent, the SDA line must be set to tri-state no later than at the falling edge of SCL of the last bit.

9.4.3 3-line Serial Protocol

3-line Serial Protocol (for RDID1/RDID2/RDID3/0Ah/0Bh/0Ch/0Dh/0Eh/0Fh Command: 8-bit Read):

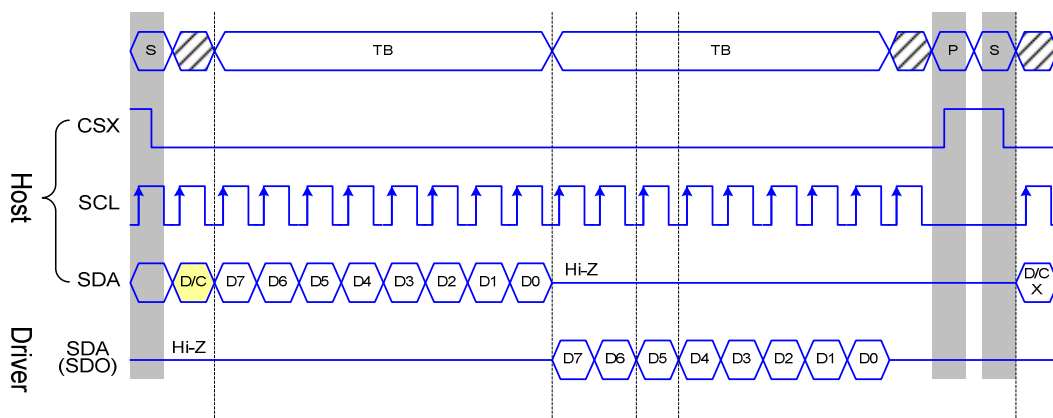

3-line Serial Protocol (for RDDID Command: 24-bit Read)

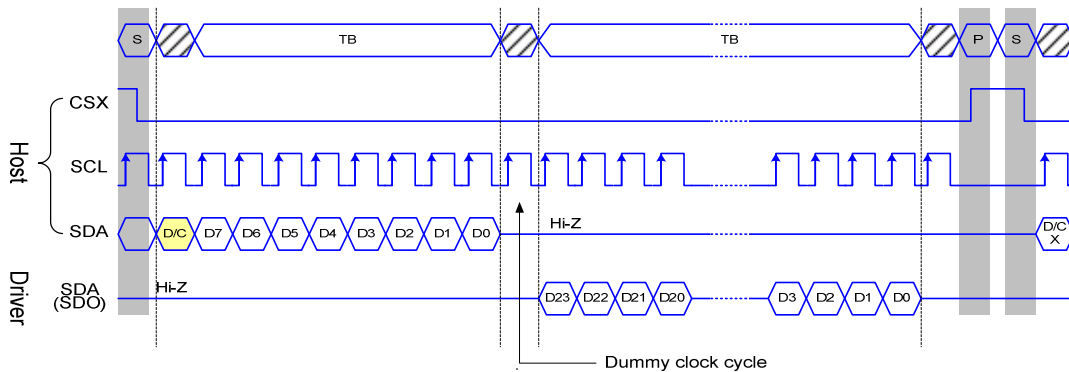

3-line Serial Protocol (for RDDST Command: 32-bit Read)

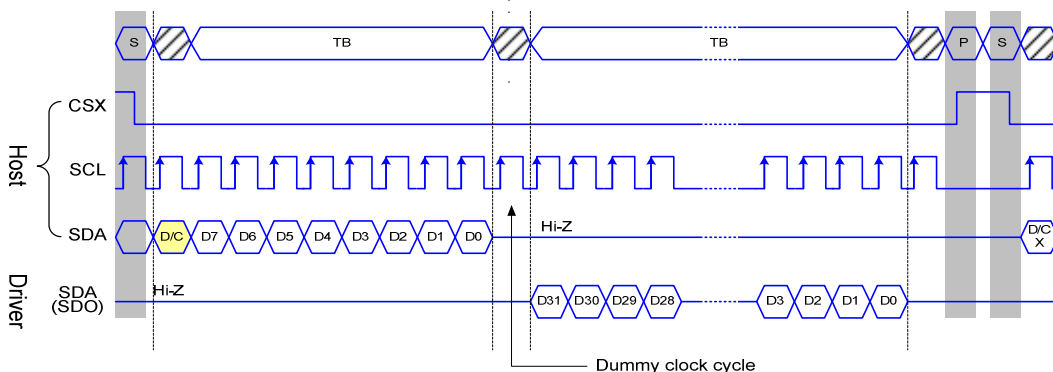
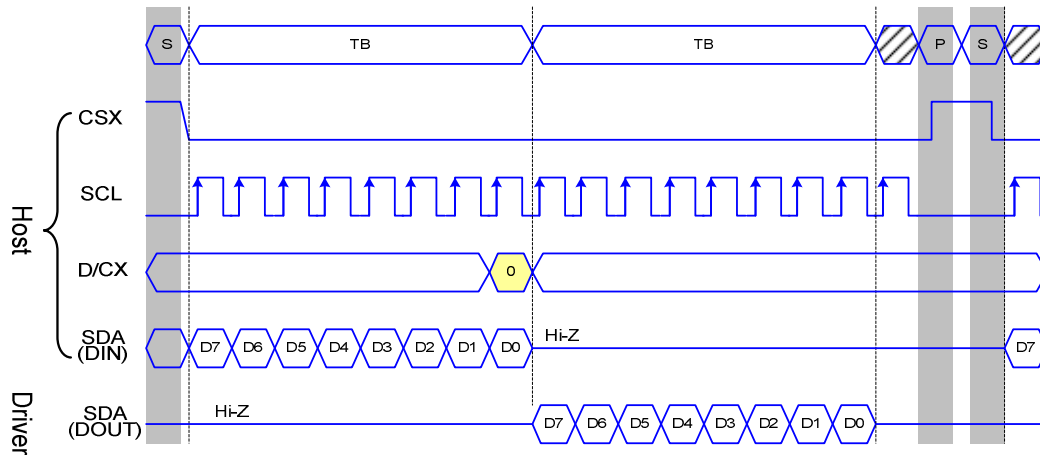

Figure 19 3-line Serial Interface Read Protocol

9.4.4 4-line Serial Protocol

4-line Serial Protocol (for RDID1/RDID2/RDID3/0Ah/0Bh/0Ch/0Dh/0Eh/0Fh Command: 8-bit Read):



4-line Serial Protocol (for RDDID Command: 24-bit Read)

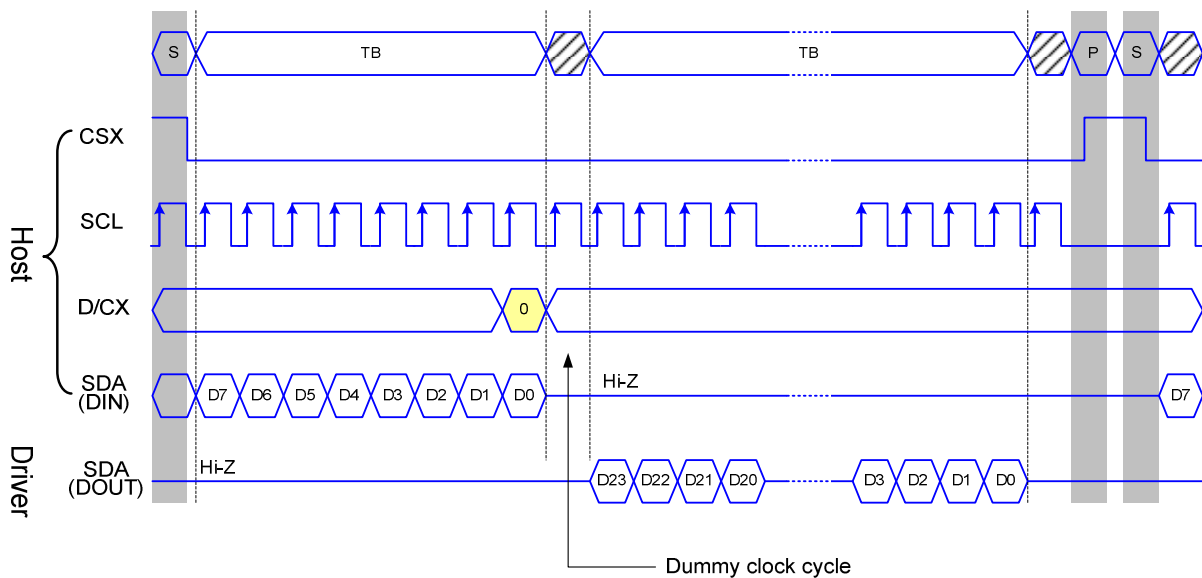

4-line Serial Protocol (for RDDST Command: 32-bit Read)

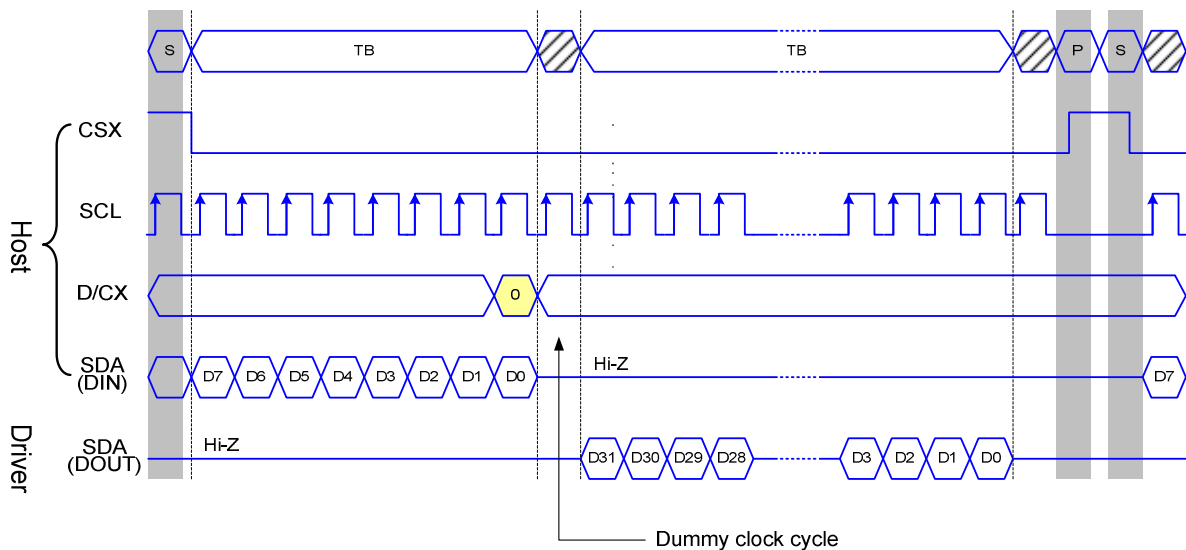

Figure 20 4-line Serial Interface Read Protocol

9.5 Data Transfer Break and Recovery

If there is a break in data transmission by RESX pulse, while transferring a command or frame memory data or multiple parameter command data, before Bit D0 of the byte has been completed, then driver will reject the previous bits and have reset the interface such that it will be ready to receive command data again when the chip select line (CSX) is next activated after RESX have been HIGH state. See the following example

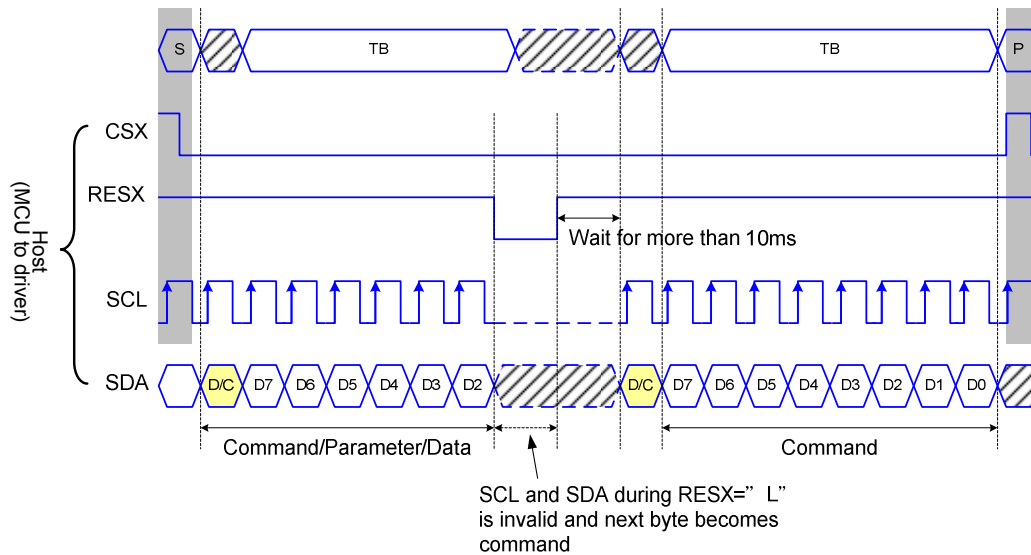

Figure 21 Serial Bus Protocol, Write Mode – Interrupted by RESX

If there is a break in data transmission by CSX pulse, while transferring a command or frame memory data or multiple parameter command data, before Bit D0 of the byte has been completed, then driver will reject the previous bits and have reset the interface such that it will be ready to receive the same byte re-transmitted when the chip select line (CSX) is next activated. See the following example

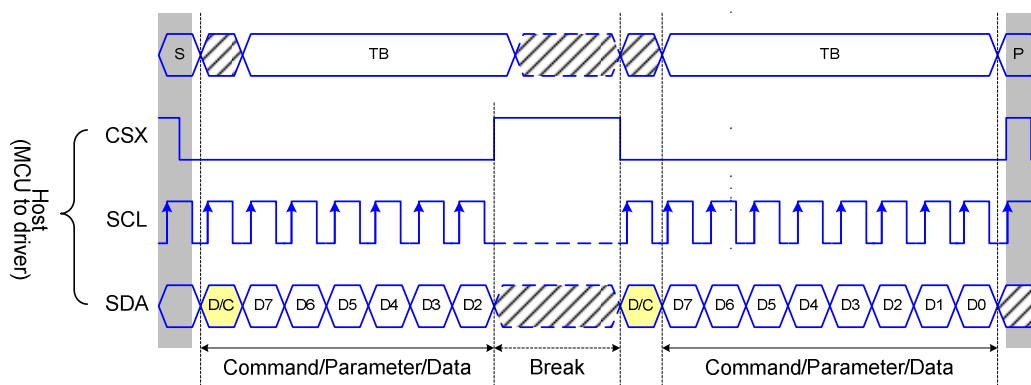

Figure 22 Serial Bus Protocol, Write Mode – Interrupted by CSX

If 1, 2 or more parameter commands are being sent and a break occurs while sending any parameter before the last one and if the host then sends a new command rather than re-transmitting the parameter that was interrupted, then the parameters that were successfully sent are stored and the parameter where the break occurred is rejected. The interface is ready to receive next byte as shown below.

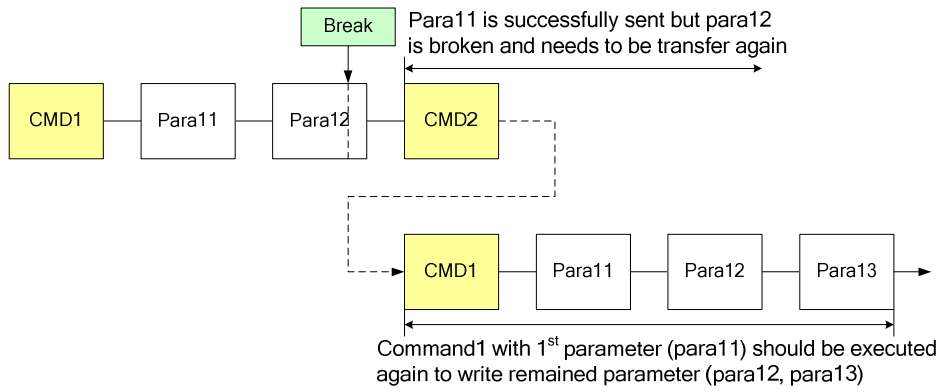

Figure 23 Write Interrupts Recovery (Serial Interface)

If a 2 or more parameter commands are being sent and a break occurs by the other command before the last one is sent, then the parameters that were successfully sent are stored and the other parameter of that command remains previous value.

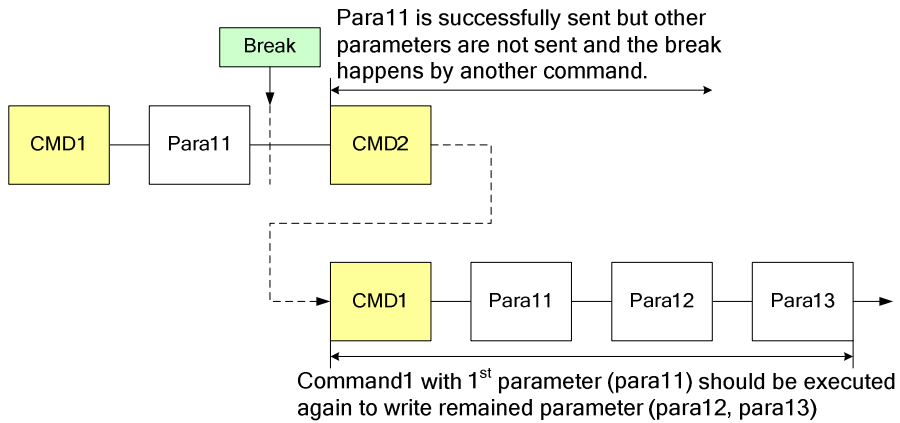

Figure 24 Write Interrupts Recovery (Both Serial and Parallel Interface)

9.6 Data Transfer Pause

It will be possible when transferring a command, frame memory data or multiple parameter data to invoke a pause in the data transmission. If the chip select line is released after a whole byte of a frame memory data or multiple parameter data has been completed, then driver will wait and continue the frame memory data or parameter data transmission from the point where it was paused. If the chip select Line is released after a whole byte of a command has been completed, then the display module will receive either the command's parameters (if appropriate) or a new command when the chip select line is next enabled as shown below.

This applies to the following 4 conditions:

- 1) Command-Pause-Command
- 2) Command-Pause-Parameter
- 3) Parameter-Pause-Command
- 4) Parameter-Pause-Parameter

9.6.1 Serial Interface Pause

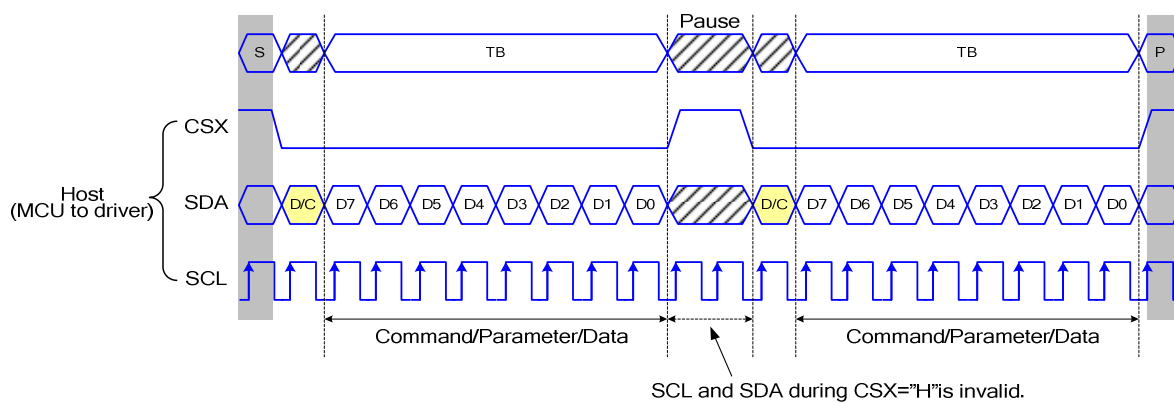

Figure 25 Serial Interface Pause Protocol (Pause by CSX)

9.6.2 Parallel Interface Pause

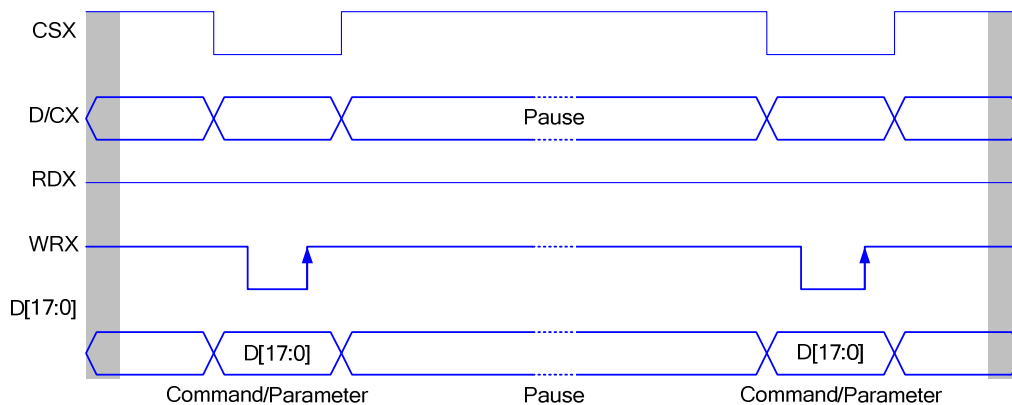

Figure 26 Parallel Bus Pause Protocol (Paused by CSX)

9.7 Data Transfer Modes

The module has three kinds color modes for transferring data to the display RAM. These are 12-bit color per pixel, 16-bit color per pixel and 18-bit color per pixel. The data format is described for each interface. Data can be downloaded to the frame memory by 2 methods.

9.7.1 Method 1

The image data is sent to the frame memory in successive frame writes, each time the frame memory is filled, the frame memory pointer is reset to the start point and the next frame is written.

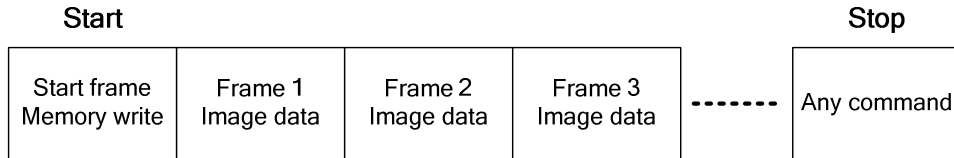

9.7.2 Method 2

The image data is sent and at the end of each frame memory download, a command is sent to stop frame memory write. Then start memory write command is sent, and a new frame is downloaded.

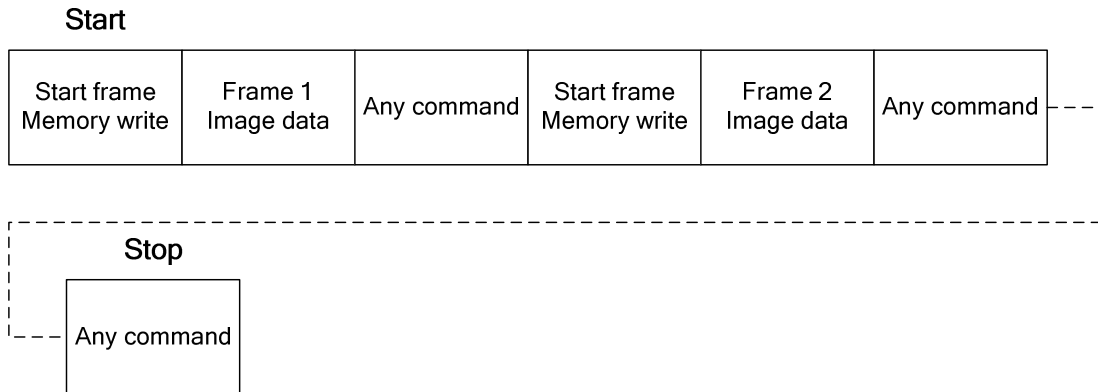

Note 1: These apply to all data transfer Color modes on both serial and parallel interfaces.

Note 2: The frame memory can contain both odd and even number of pixels for both methods. Only complete pixel data will be stored in the frame memory.

9.8 Data Color Coding

9.8.1 8-bit Parallel Interface (IM2, IM1, IM0= "100")

Different display data formats are available for three Colors depth supported by listed below.

- 4k Colors, RGB 4,4,4-bit Input.
- 65k Colors, RGB 5,6,5-bit Input.
- 262k Colors, RGB 6,6,6-bit Input.

9.8.2 8-bit Data Bus for 12-bit/Pixel (RGB 4-4-4-bit Input), 4K-Colors, 3AH= "03h"

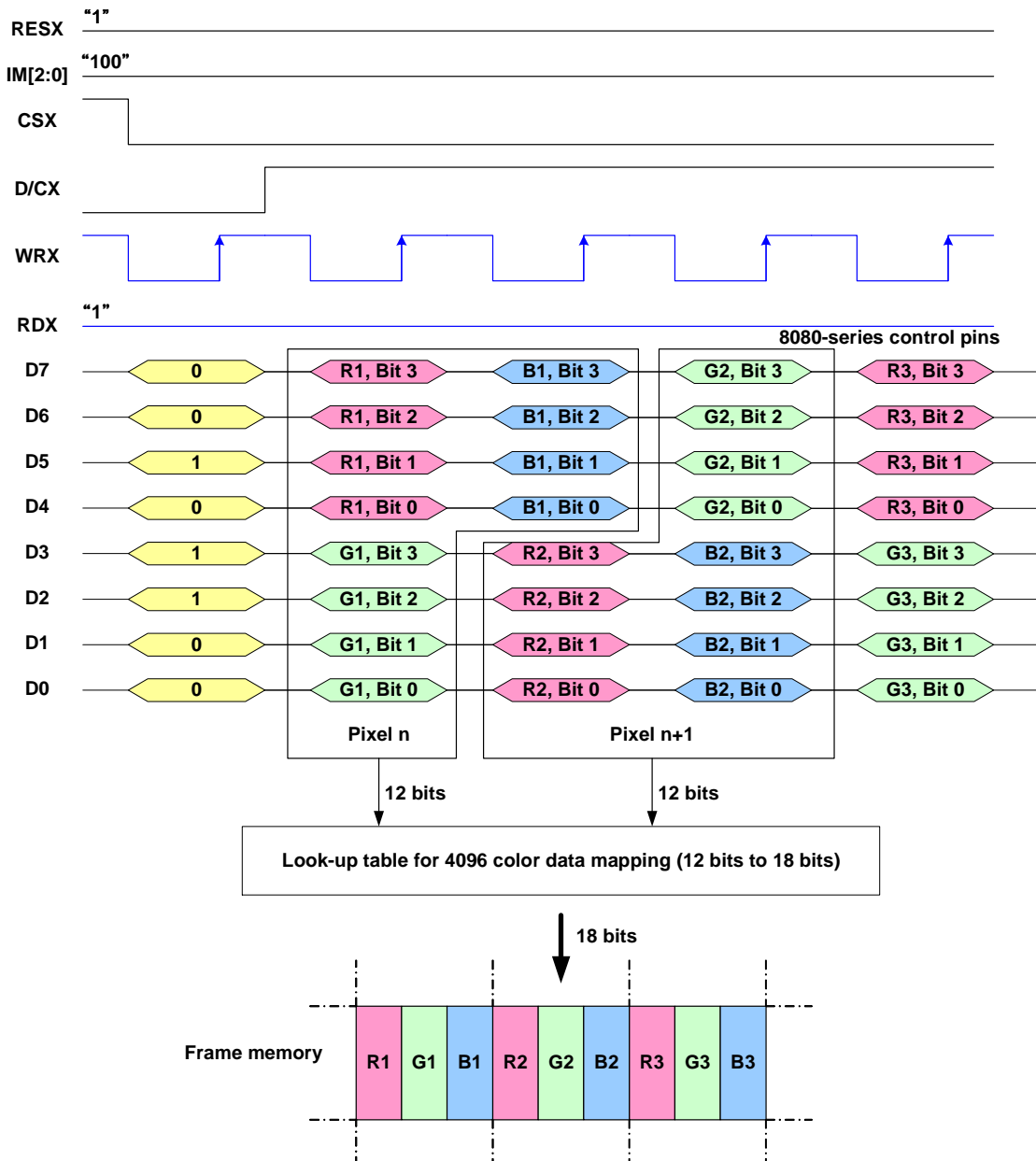

Note 1: The data order is as follows, MSB=D7, LSB=D0 and picture data is MSB=Bit 3, LSB=Bit 0 for Red, Green and Blue data.

Note 2: 3-time transfer is used to transmit 1 pixel data with the 12-bit color depth information.

Note 3: '-' = Don't care - Can be set to '0' or '1'

9.8.3 8-bit Data Bus for 16-bit/Pixel (RGB 5-6-5-bit Input), 65K-Colors, 3AH= "05h"

There is 1 pixel (3 sub-pixels) per 2-byte

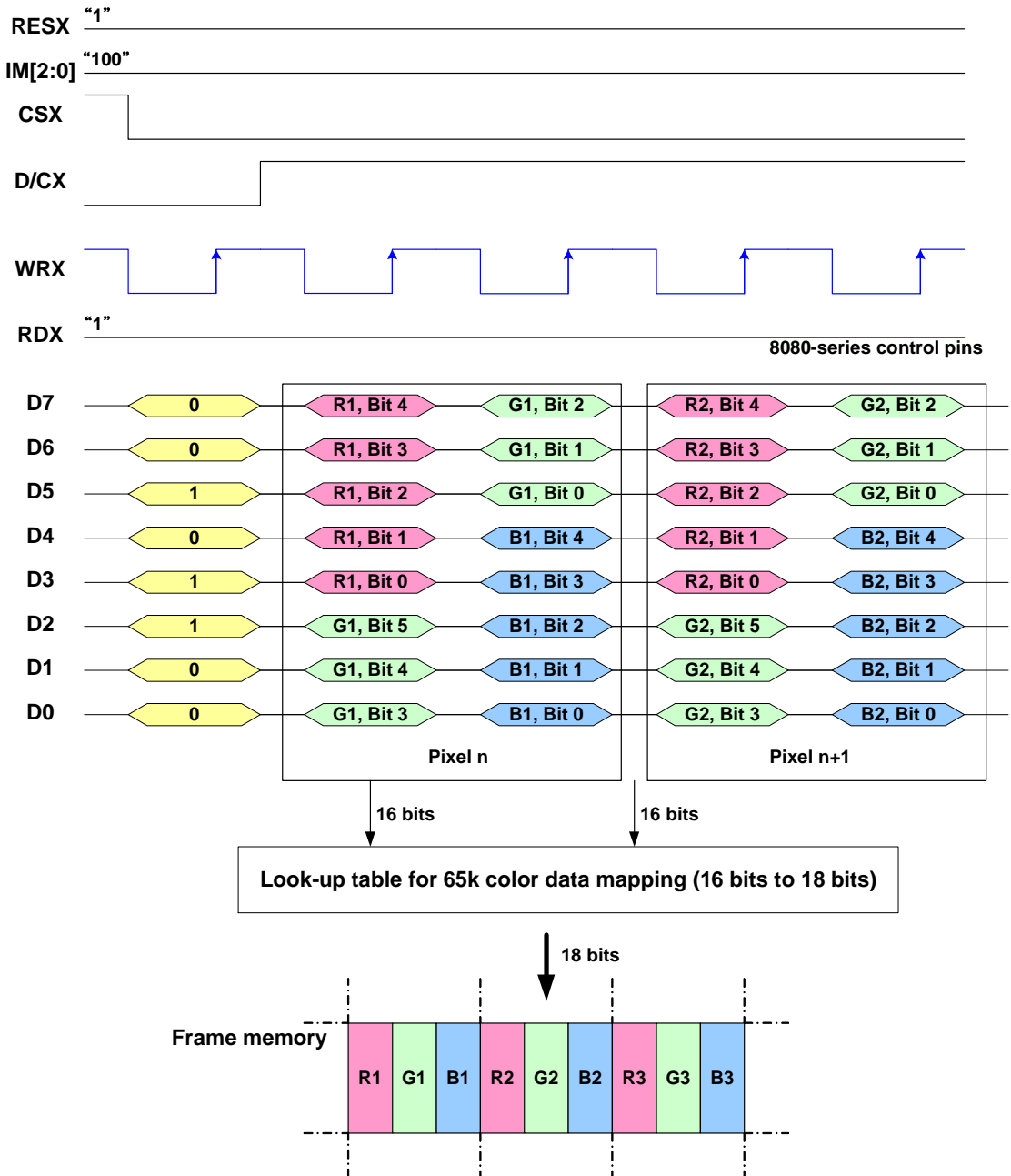

Note 1: The data order is as follows, MSB=D7, LSB=D0 and picture data is MSB=Bit 5, LSB=Bit 0 for Green and MSB=Bit 4, LSB=Bit 0 for Red and Blue data.

Note 2: 2-times transfer is used to transmit 1 pixel data with the 16-bit color depth information.

Note 3: '-' = Don't care - Can be set to '0' or '1'

9.8.4 8-bit Data Bus for 18-bit/Pixel (RGB 6-6-6-bit Input), 262K-Colors, 3AH= "06h"

There is 1 pixel (3 sub-pixels) per 3-bytes.

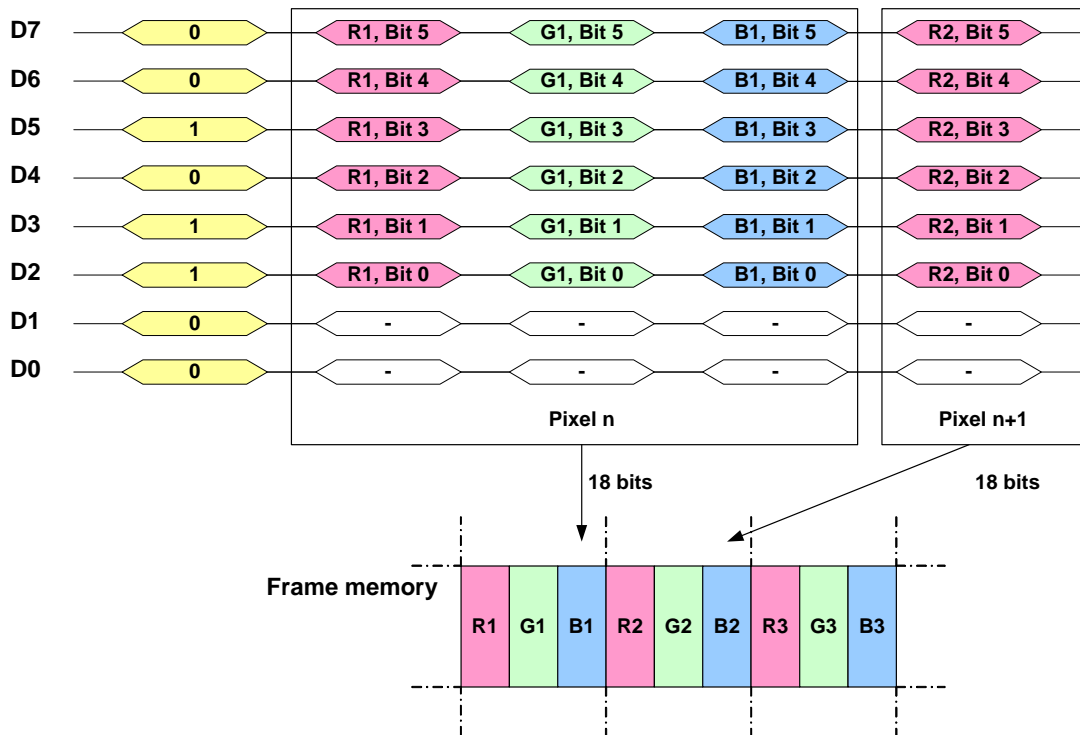
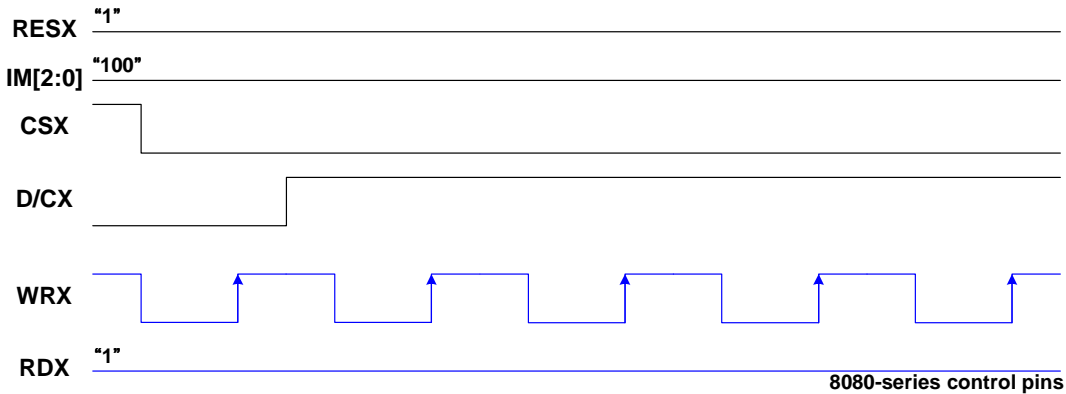

Note 1: The data order is as follows, MSB=D7, LSB=D0 and picture data is MSB=Bit 5, LSB=Bit 0 for Red, Green and Blue data.
 Note 2: 3-times transfer is used to transmit 1 pixel data with the 18-bit color depth information.
 Note 3: '-' = Don't care - Can be set to '0' or '1'

9.8.5 16-Bit Parallel Interface (IM2,IM1, IM0= "101")

Different display data formats are available for three colors depth supported by listed below.

- 4k Colors, RGB 4,4,4-bit Input
- 65k Colors, RGB 5,6,5-bit Input
- 262k Colors, RGB 6,6,6-bit Input

9.8.6 16-bit Data Bus for 12-bit/Pixel (RGB 4-4-4-bit Input), 4K-Colors, 3AH= "03h"

There is 1 pixel (3 sub-pixels) per 1 byte

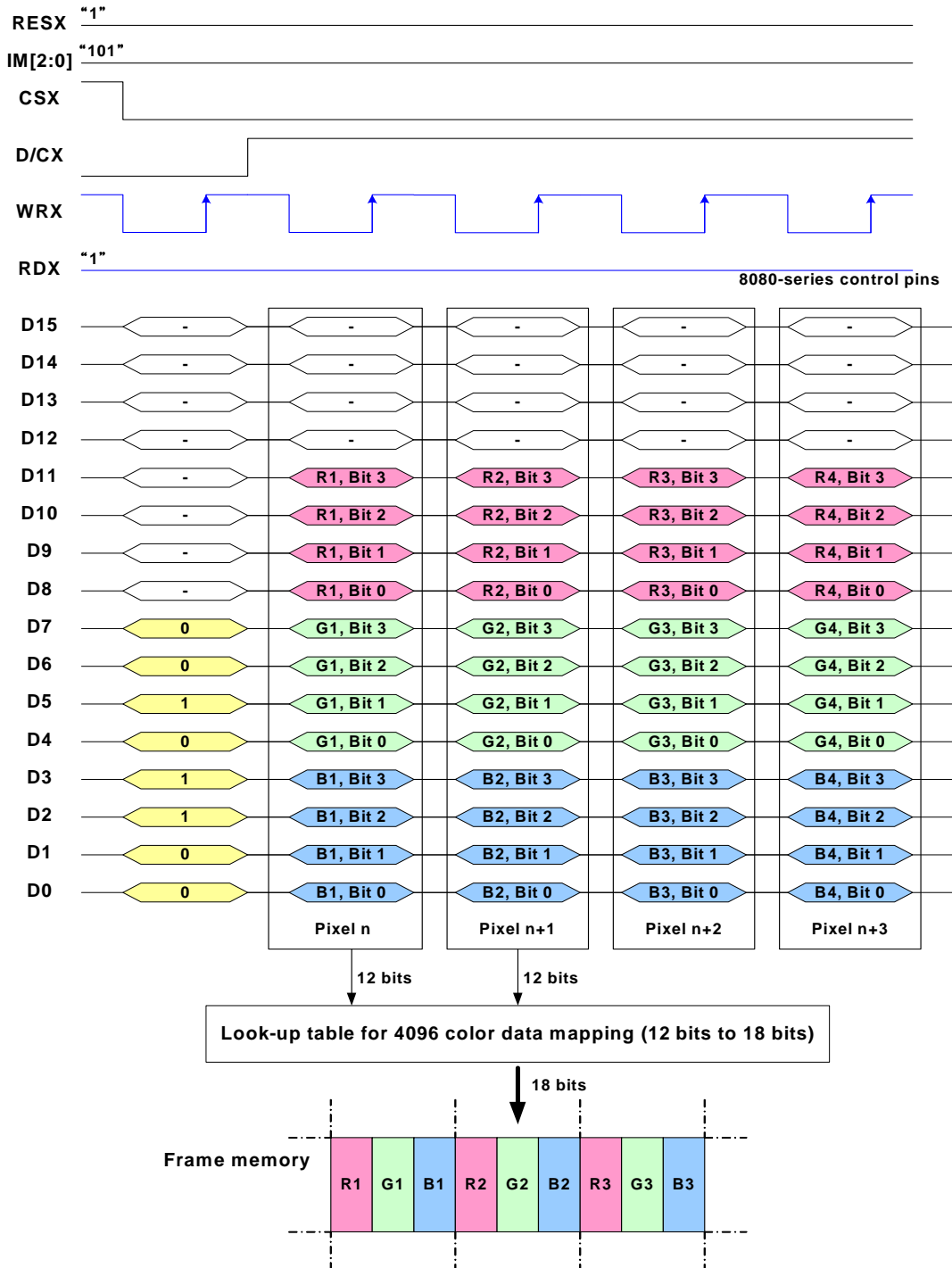

Note 1: The data order is as follows, MSB=D11, LSB=D0 and picture data is MSB=Bit 3, LSB=Bit 0 for Red, Green and Blue data.
 Note 2: 1-times transfer (D11 to D0) is used to transmit 1 pixel data with the 12-bit color depth information.

9.8.7 16-bit Data Bus for 16-bit/Pixel (RGB 5-6-5-bit Input), 65K-Colors, 3AH= "05h"

There is 1 pixel (3 sub-pixels) per 1 byte

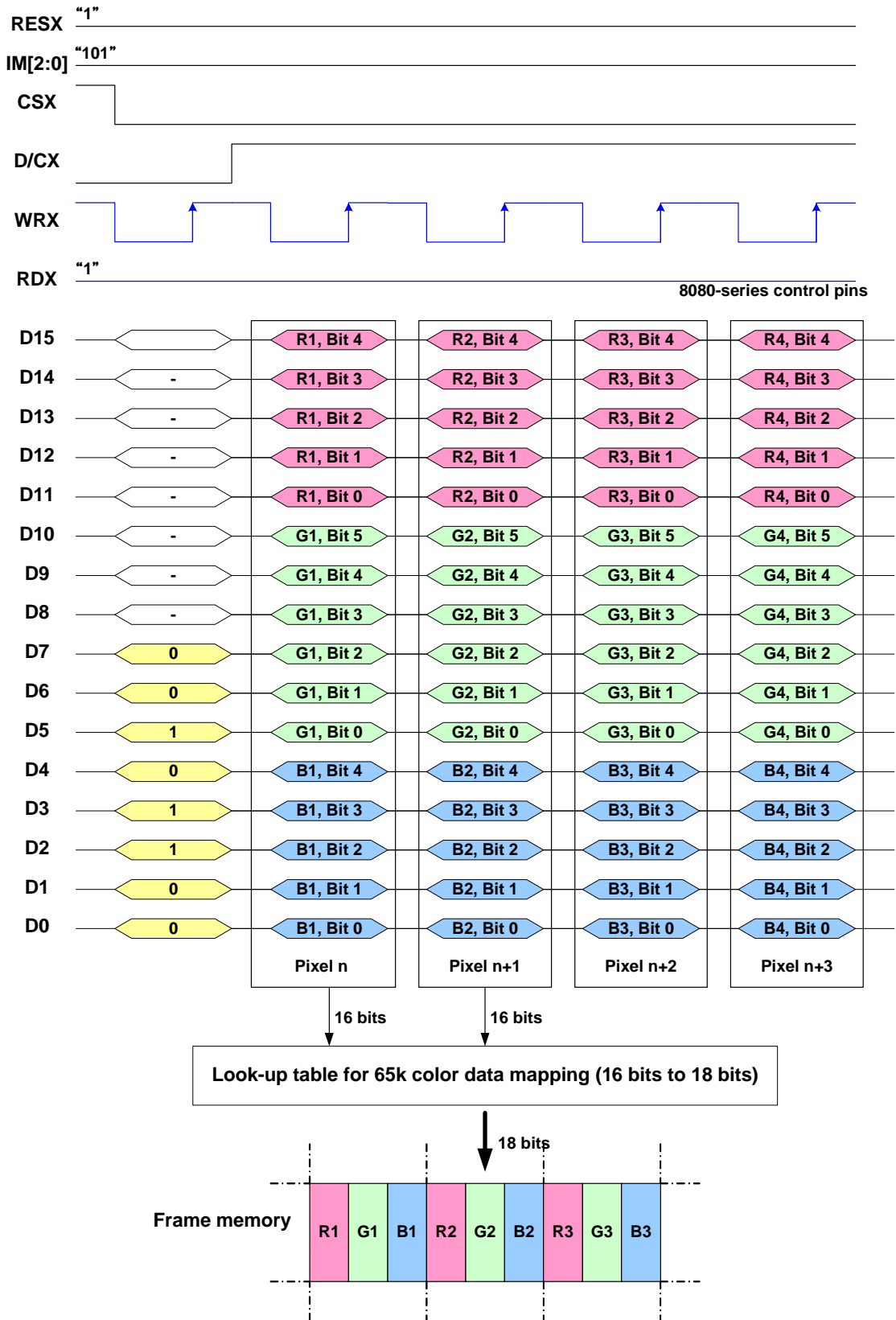

Note 1: The data order is as follows, MSB=D15, LSB=D0 and picture data is MSB=Bit 5, LSB=Bit 0 for Green, and MSB=Bit 4, LSB=Bit 0 for Red and Blue data.

Note 2: 1-times transfer (D15 to D0) is used to transmit 1 pixel data with the 16-bit color depth information.

Note 3: '-' = Don't care - Can be set to '0' or '1'

9.8.8 16-bit Data Bus for 18-bit/Pixel (RGB 6-6-6-bit Input), 262K-Colors, 3AH= "06h"

There are 2 pixels (6 sub-pixels) per 3 bytes

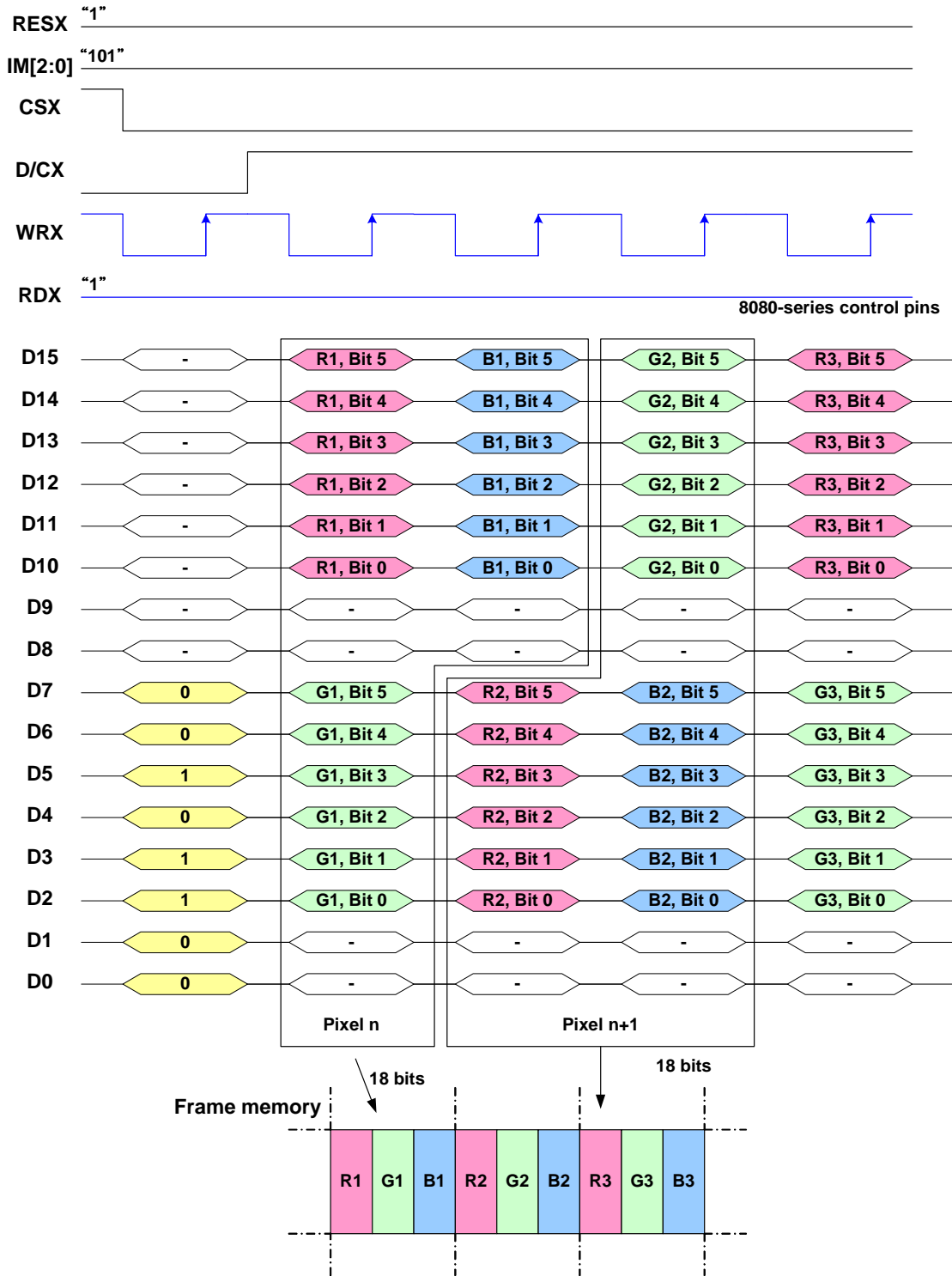

Note 1: The data order is as follows, MSB=D15, LSB=D0 and picture data is MSB=Bits 5, LSB=Bit 0 for Red, Green and Blue data.

Note 2: 3-times transfer is used to transmit 1 pixel data with the 18-bit color depth information.

Note 3: '-' = Don't care - Can be set to '0' or '1'

9.8.9 9-Bit Parallel Interface (IM2, IM1, IM0="110")

Different display data formats are available for three colors depth supported by listed below.

-262k colors, RGB 6,6,6-bit input

9.8.10 Write 9-bit Data for RGB 6-6-6-bit Input (262k-color)

There is 1 pixel (6 sub-pixels) per 3 bytes

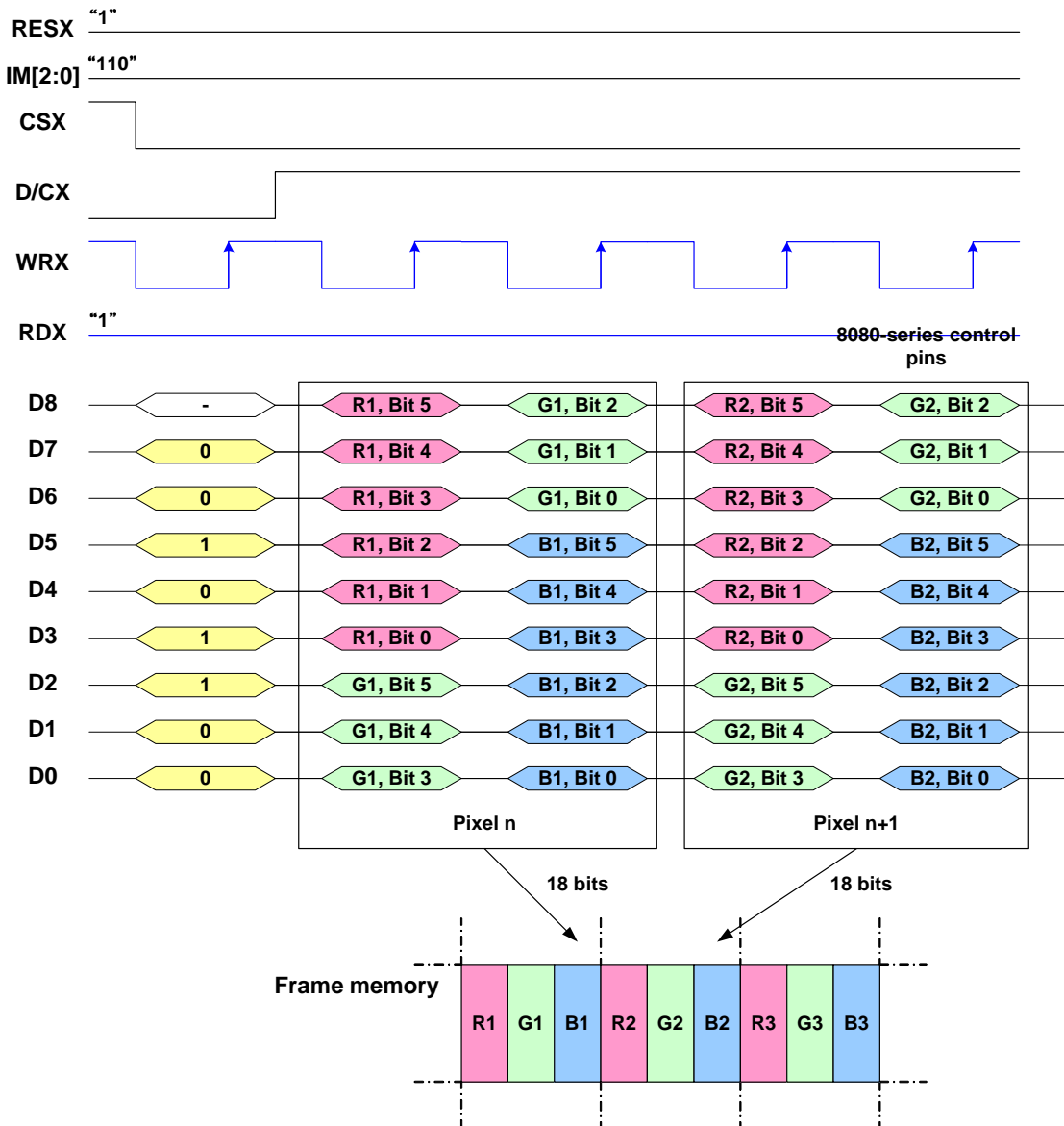

Note 1: The data order is as follows, MSB=D8, LSB=D0 and picture data is MSB=Bit 5, LSB=Bit 0 for Red, Green and Blue data.

Note 2: 3-times transfer is used to transmit 1 pixel data with the 18-bit color depth information.

Note 3: '-' = Don't care - Can be set to '0' or '1'

9.8.11 18-Bit Parallel Interface (IM2, IM1, IM0="111")

Different display data formats are available for three colors depth supported by listed below.

- 4k Colors, RGB 4,4,4-bit Input
- 65k Colors, RGB 5,6,5-bit Input
- 262k Colors, RGB 6,6,6-bit Input.

9.8.12 18-bit Data Bus for 12-bit/Pixel (RGB 4-4-4-bit Input), 4K-Colors, 3AH="03h"

There is 1 pixel (3 sub-pixels) per 1 byte

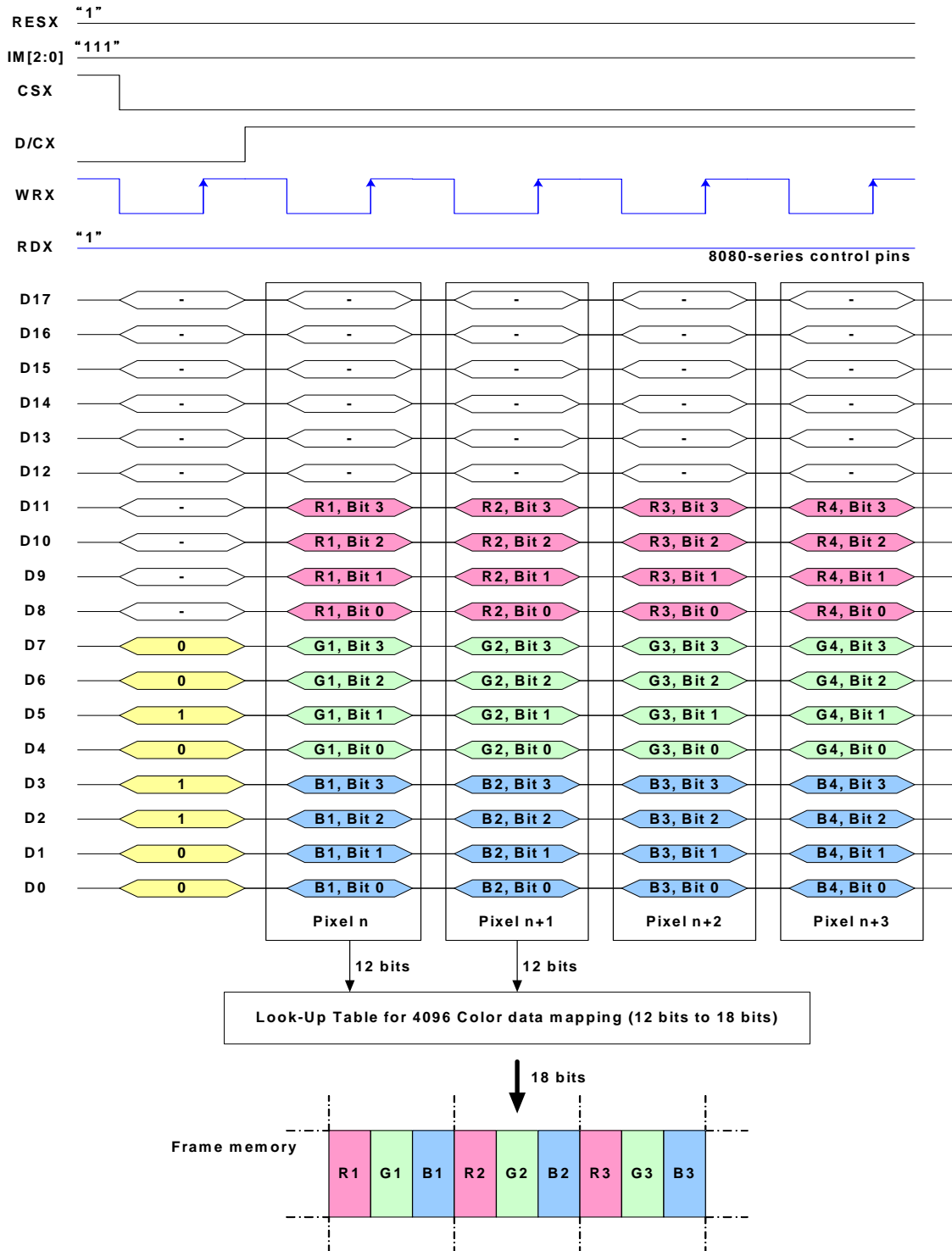

Note 1: The data order is as follows, MSB=D11, LSB=D0 and picture data is MSB=Bit 3, LSB=Bit 0 for Red, Green and Blue data.
 Note 2: 1-times transfer is used to transmit 1 pixel data with the 12-bit color depth information.

9.8.13 18-bit Data Bus for 16-bit/Pixel (RGB 5-6-5-bit Input), 65K-Colors, 3AH="05h"

There is 1 pixel (3 sub-pixels) per 1 byte

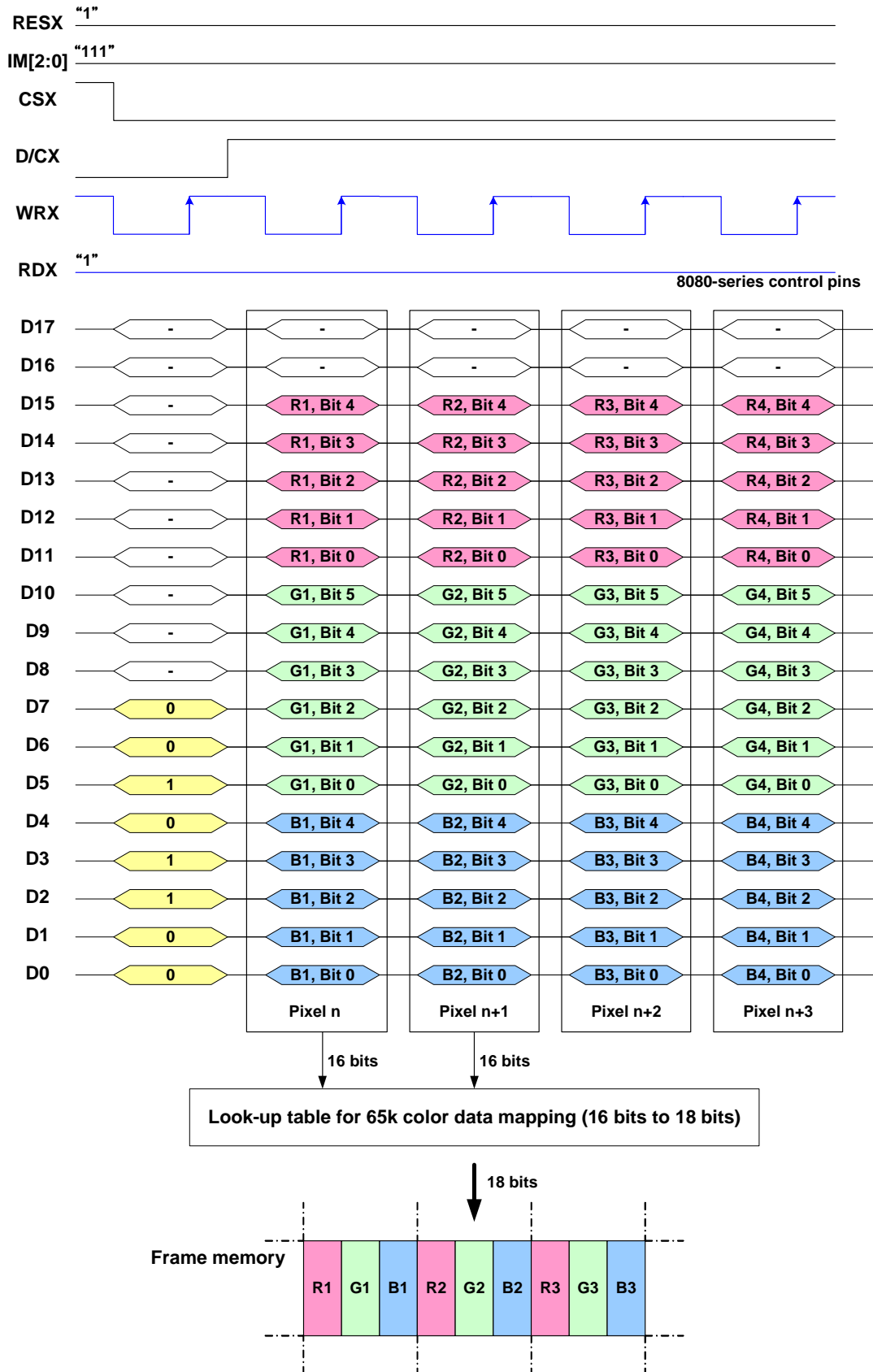

Note 1: The data order is as follows, MSB=D15, LSB=D0 and picture data is MSB=Bit 5, LSB=Bit 0 for Green, and MSB=Bit 4, LSB=Bit 0 for Red and Blue data.

Note 2: 1-time transfer is used to transmit 1 pixel data with the 16-bit color depth information.

9.8.14 18-bit Data Bus for 18-bit/Pixel (RGB 6-6-6-bit Input), 262K-Colors, 3AH="06h"

There is 1 pixel (3 sub-pixels) per 1 byte

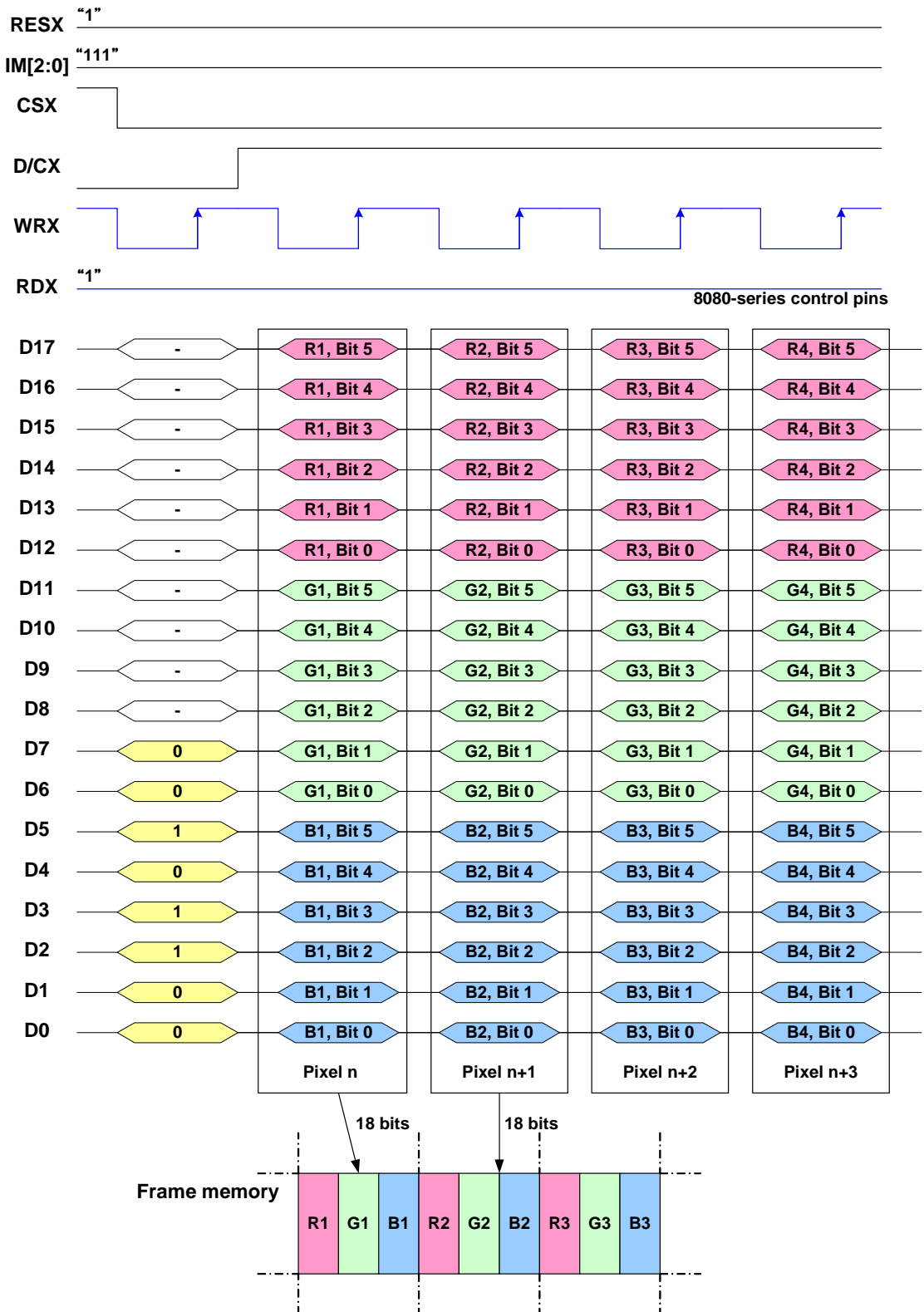

Note 1: The data order is as follows, MSB=D17, LSB=D0 and picture data is MSB=Bit 5, LSB=Bit 0 for Read, Green and Blue data.

Note 2: 1-times transfer (D17o D0) is used to transmit 1 pixel data with the 18-bit color depth information.

9.8.15 3-line Serial Interface

Different display data formats are available for three colors depth supported by the LCM listed below.

4k Colors, RGB 4-4-4-bit Input

65k Colors, RGB 5-6-5-bit Input

262k Colors, RGB 6-6-6-bit Input

9.8.16 Write Data for 12-bit/Pixel (RGB 4-4-4-bit Input), 4K-Colors, 3AH="03h"

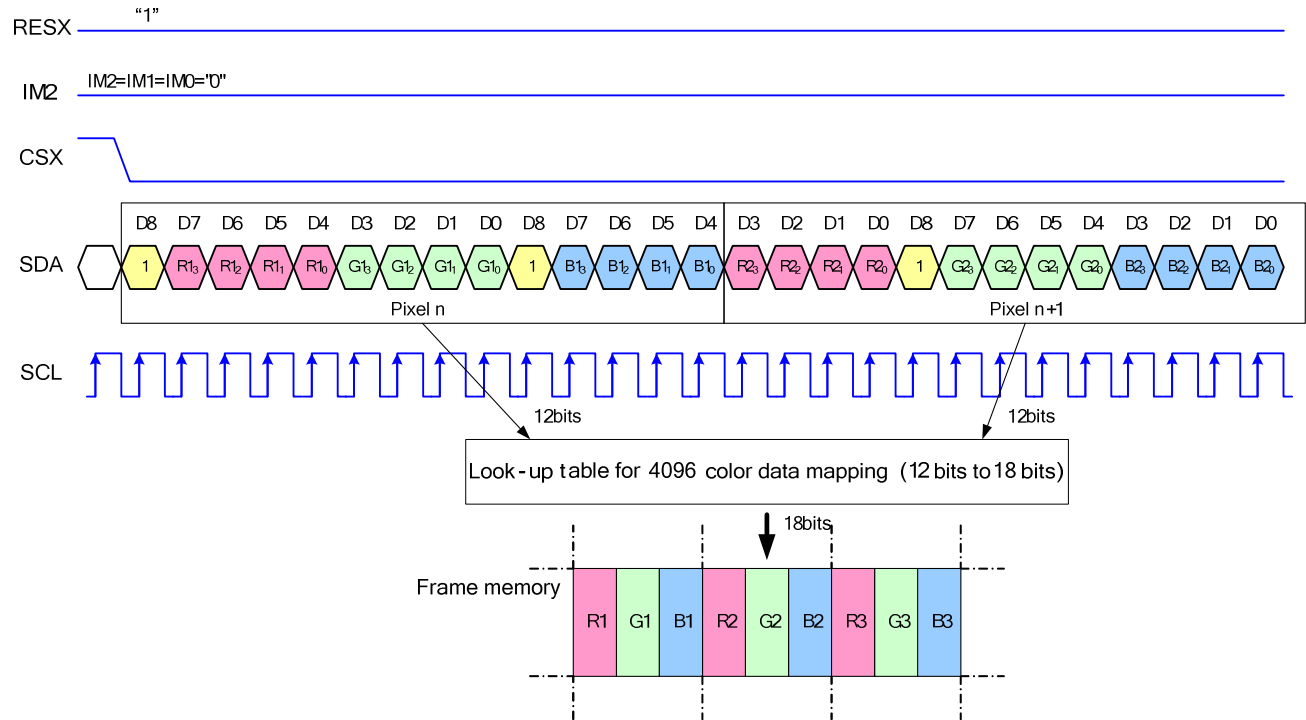

Note 1: Pixel data with the 12-bit color depth information

Note 2: The most significant bits are: Rx3, Gx3 and Bx3

Note 3: The least significant bits are: Rx0, Gx0 and Bx0

9.8.17 Write Data for 16-bit/Pixel (RGB 5-6-5-bit Input), 65K-Colors, 3AH="05h"

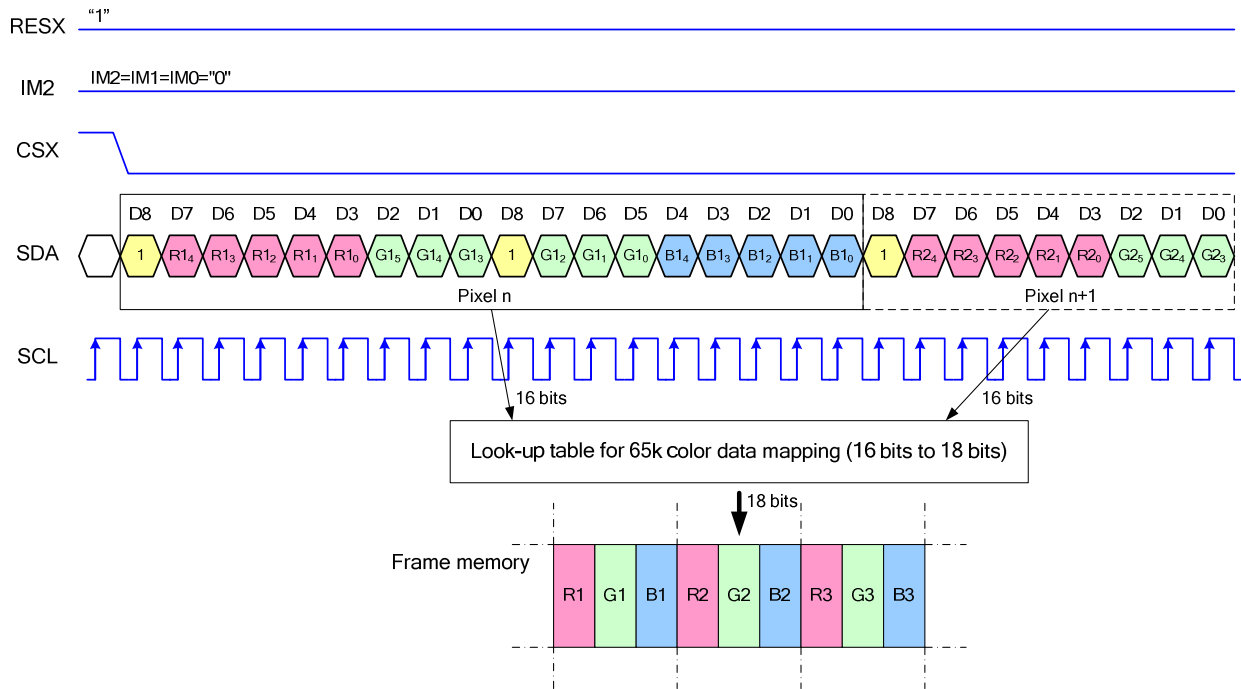

- Note 1: Pixel data with the 16-bit color depth information
- Note 2: The most significant bits are: Rx4, Gx5 and Bx4
- Note 3: The least significant bits are: Rx0, Gx0 and Bx0

9.8.18 Write Data for 18-bit/Pixel (RGB 6-6-6-bit Input), 262K-Colors, 3AH="06h"

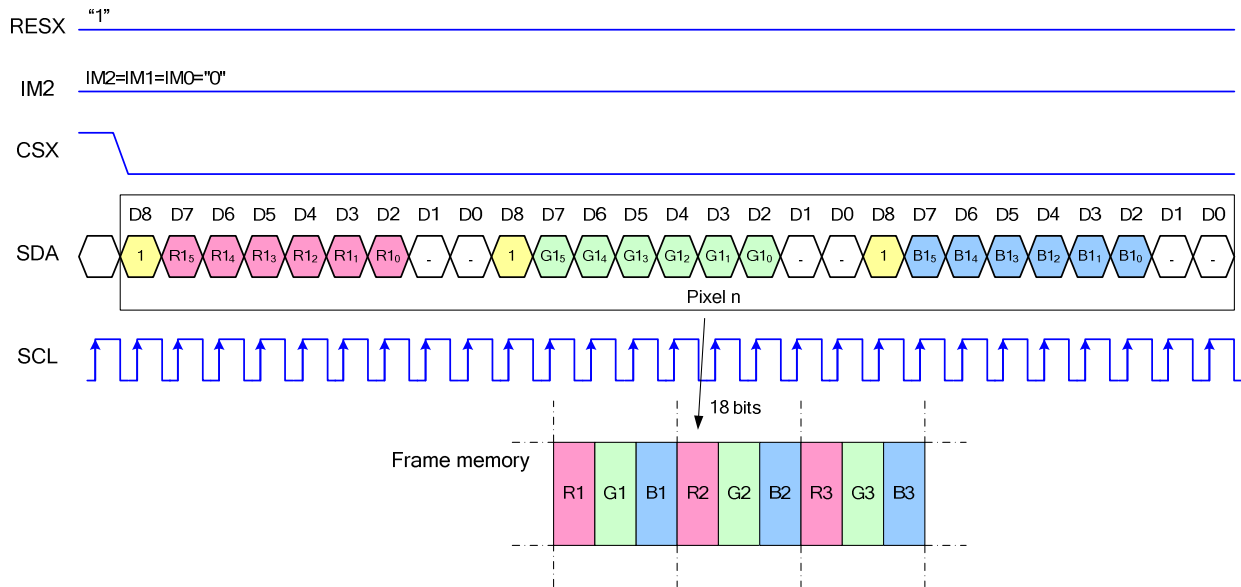

- Note 1: Pixel data with the 18-bit color depth information
- Note 2: The most significant bits are: Rx5, Gx5 and Bx5
- Note 3: The least significant bits are: Rx0, Gx0 and Bx0

9.8.19 4-line Serial Interface

Different display data formats are available for three colors depth supported by the LCM listed below.

4k Colors, RGB 4-4-4-bit Input

65k Colors, RGB 5-6-5-bit Input

262k Colors, RGB 6-6-6-bit Input

9.8.20 Write Data for 12-bit/Pixel (RGB 4-4-4-bit Input), 4K-Colors, 3AH="03h"

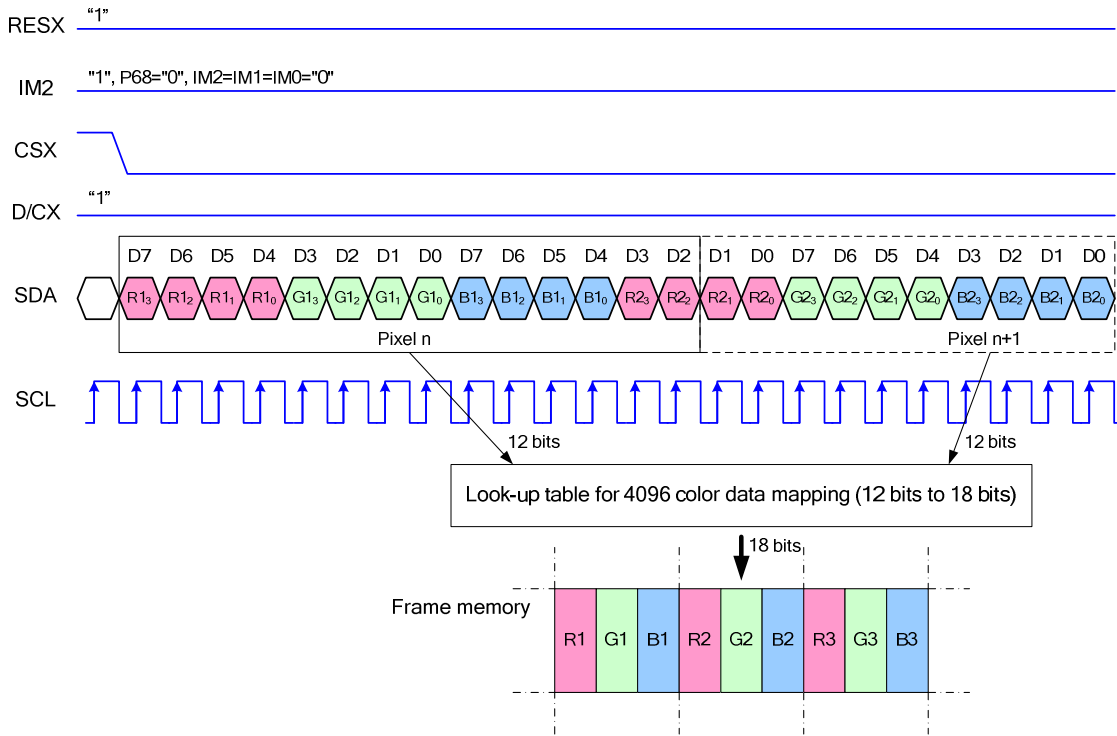

Note 1. pixel data with the 12-bit color depth information

Note 2. The most significant bits are: Rx3, Gx3 and Bx3

Note 3. The least significant bits are: Rx0, Gx0 and Bx0

9.8.21 Write Data for 16-bit/Pixel (RGB 5-6-5-bit Input), 65K-Colors, 3AH="05h"

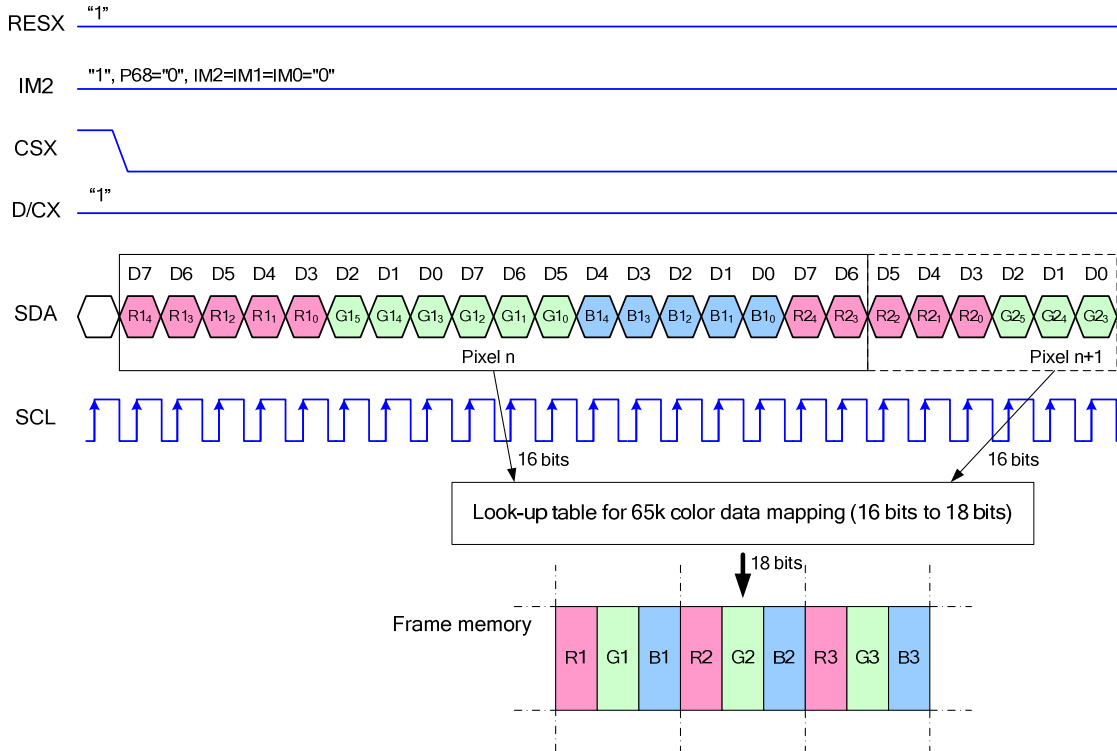

- Note 1. pixel data with the 16-bit color depth information
- Note 2. The most significant bits are: Rx4, Gx5 and Bx4
- Note 3. The least significant bits are: Rx0, Gx0 and Bx0

9.8.22 Write Data for 18-bit/Pixel (RGB 6-6-6-bit Input), 262K-Colors, 3AH="06h"

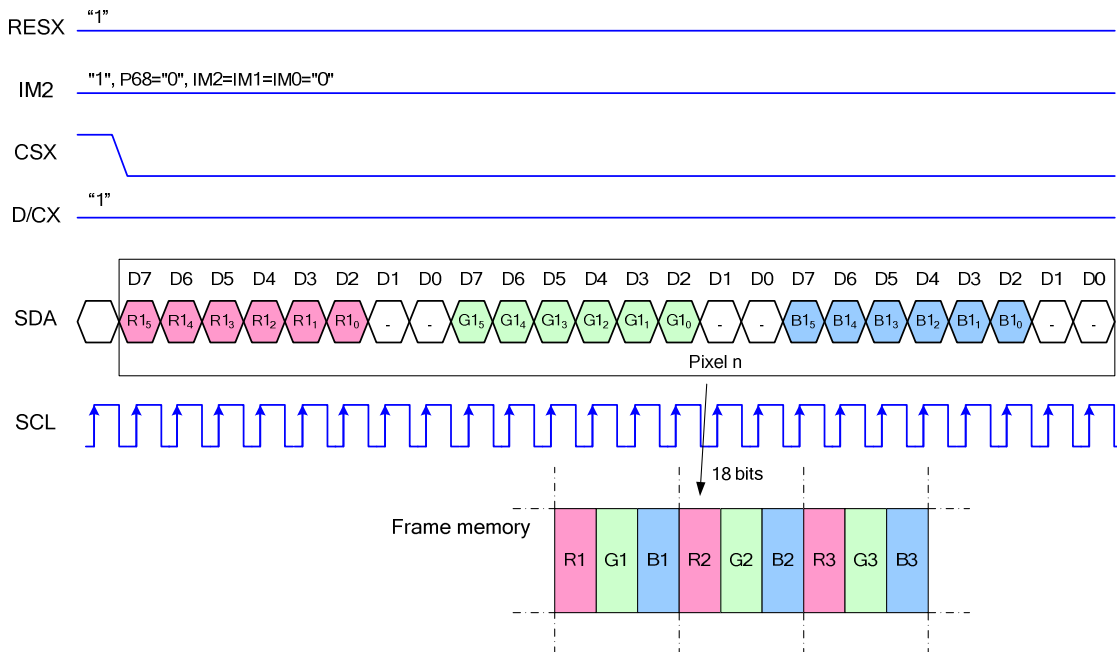

- Note 1. pixel data with the 18-bit color depth information
- Note 2. The most significant bits are: Rx5, Gx5 and Bx5
- Note 3. The least significant bits are: Rx0, Gx0 and Bx0

9.9 Display Data RAM

9.9.1 Configuration (GM[1:0] = "00")

The display module has an integrated 132x162x18-bit graphic type static RAM. This 384,912-bit memory allows storing on-chip a 132xRGBx162 image with an 18-bpp resolution (262K-color). There will be no abnormal visible effect on the display when there is a simultaneous Panel Read and Interface Read or Write to the same location of the Frame Memory.

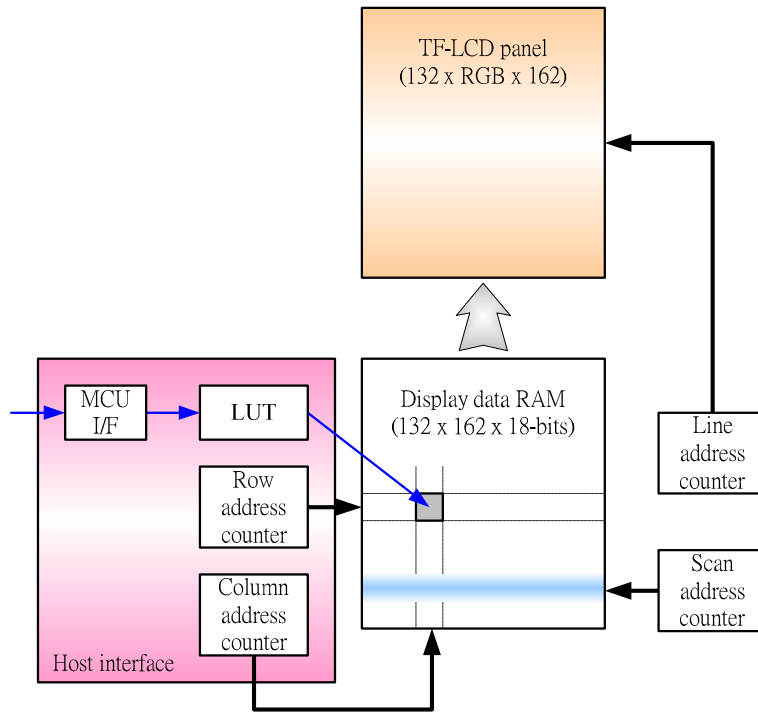

Figure 27 Display Data RAM Organization

9.9.2 Memory to Display Address Mapping

9.9.3 When using 128RGB x 160 resolution (GM[1:0] = "11", SMX=SMY=SRGB= '0')

| Gate Out | Source Out | | S7 | S8 | S9 | S10 | S11 | S12 | ----- | S385 | S386 | S387 | S388 | S389 | S390 | SA | | | |
|----------|------------|--------|-------|----|----|-------|-----|-----|-----------|-------|------|------|-------|------|------|------|-----|------|--|
| | RA | | RGB=0 | | | RGB=1 | | | RGB Order | RGB=0 | | | RGB=1 | | | ML=0 | | ML=1 | |
| | MY='0' | MY='1' | R0 | G0 | B0 | R1 | G1 | B1 | | R126 | G126 | B126 | R127 | G127 | B127 | 0 | 159 | | |
| 2 | 0 | 159 | | | | | | | ----- | | | | | | | 0 | 159 | | |
| 3 | 1 | 158 | | | | | | | ----- | | | | | | | 1 | 158 | | |
| 4 | 2 | 157 | | | | | | | ----- | | | | | | | 2 | 157 | | |
| 5 | 3 | 156 | | | | | | | ----- | | | | | | | 3 | 156 | | |
| 6 | 4 | 155 | | | | | | | ----- | | | | | | | 4 | 155 | | |
| 7 | 5 | 154 | | | | | | | ----- | | | | | | | 5 | 154 | | |
| 8 | 6 | 153 | | | | | | | ----- | | | | | | | 6 | 153 | | |
| 9 | 7 | 152 | | | | | | | ----- | | | | | | | 7 | 152 | | |
| | | | | | | | | | | | | | | | | | | | |
| | | | | | | | | | | | | | | | | | | | |
| | | | | | | | | | | | | | | | | | | | |
| | | | | | | | | | | | | | | | | | | | |
| 154 | 152 | 7 | | | | | | | ----- | | | | | | | 152 | 7 | | |
| 155 | 153 | 6 | | | | | | | ----- | | | | | | | 153 | 6 | | |
| 156 | 154 | 5 | | | | | | | ----- | | | | | | | 154 | 5 | | |
| 157 | 155 | 4 | | | | | | | ----- | | | | | | | 155 | 4 | | |
| 158 | 156 | 3 | | | | | | | ----- | | | | | | | 156 | 3 | | |
| 159 | 157 | 2 | | | | | | | ----- | | | | | | | 157 | 2 | | |
| 160 | 158 | 1 | | | | | | | ----- | | | | | | | 158 | 1 | | |
| 161 | 159 | 0 | | | | | | | ----- | | | | | | | 159 | 0 | | |
| CA | MX='0' | | 0 | | | 1 | | | ----- | 126 | | | 127 | | | | | | |
| | MX='1' | | 127 | | | 126 | | | ----- | 1 | | | 0 | | | | | | |

Note

RA = Row Address,

CA = Column Address

SA = Scan Address

MX = Mirror X-axis (Column address direction parameter), D6 parameter of MADCTL command

MY = Mirror Y-axis (Row address direction parameter), D7 parameter of MADCTL command

ML = Scan direction parameter, D4 parameter of MADCTL command

RGB = Red, Green and Blue pixel position change, D3 parameter of MADCTL command

9.9.4 When using 132RGB x 132resolution (GM[1:0] = "01", SMX=SMY=SRGB= '0')

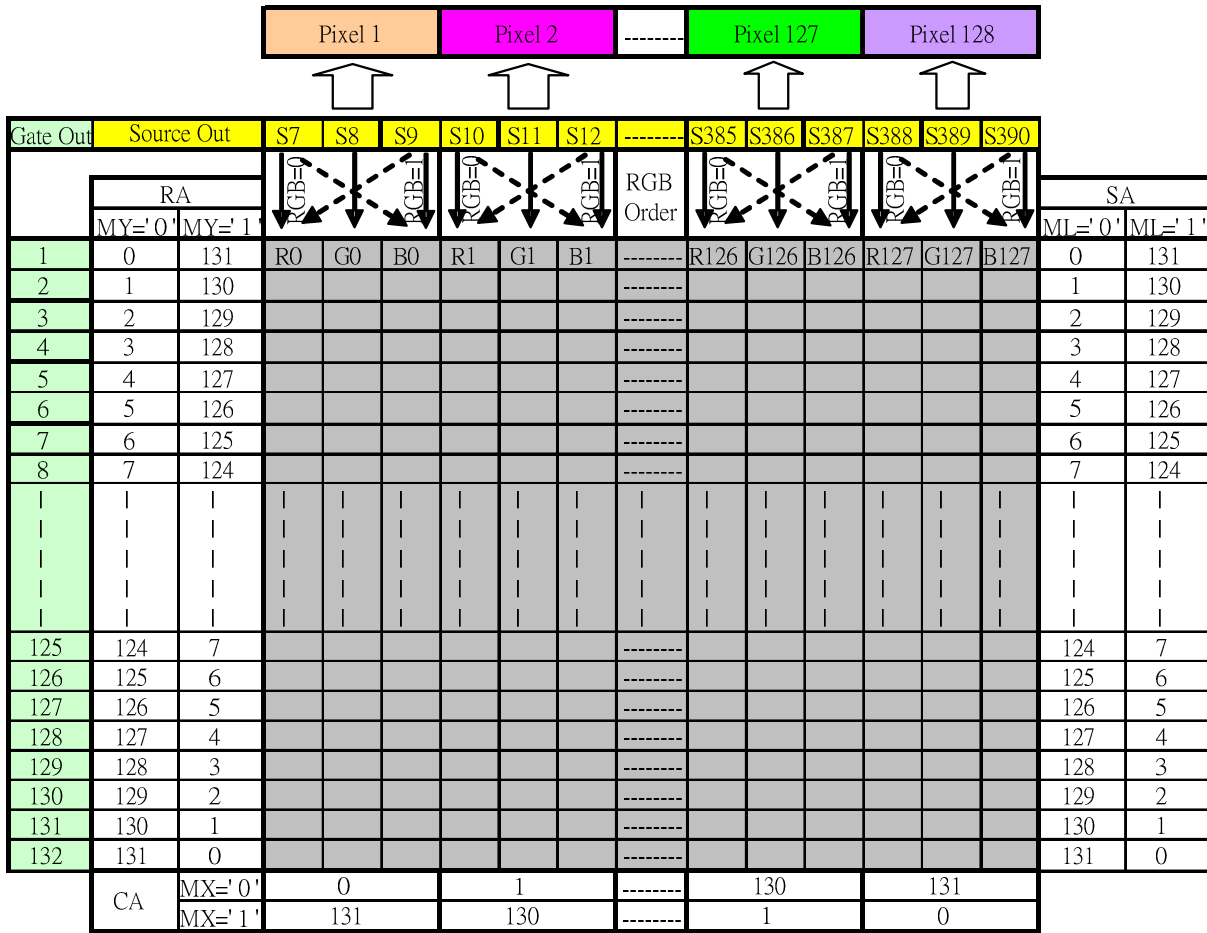

Note

RA = Row Address,

CA = Column Address

SA = Scan Address

MX = Mirror X-axis (Column address direction parameter), D6 parameter of MADCTL command

MY = Mirror Y-axis (Row address direction parameter), D7 parameter of MADCTL command

ML = Scan direction parameter, D4 parameter of MADCTL command

RGB = Red, Green and Blue pixel position change, D3 parameter of MADCTL command

9.9.5 When using 132RGB x 162 resolution (GM[1:0] = "00", SMX=SMY=SRGB= '0')

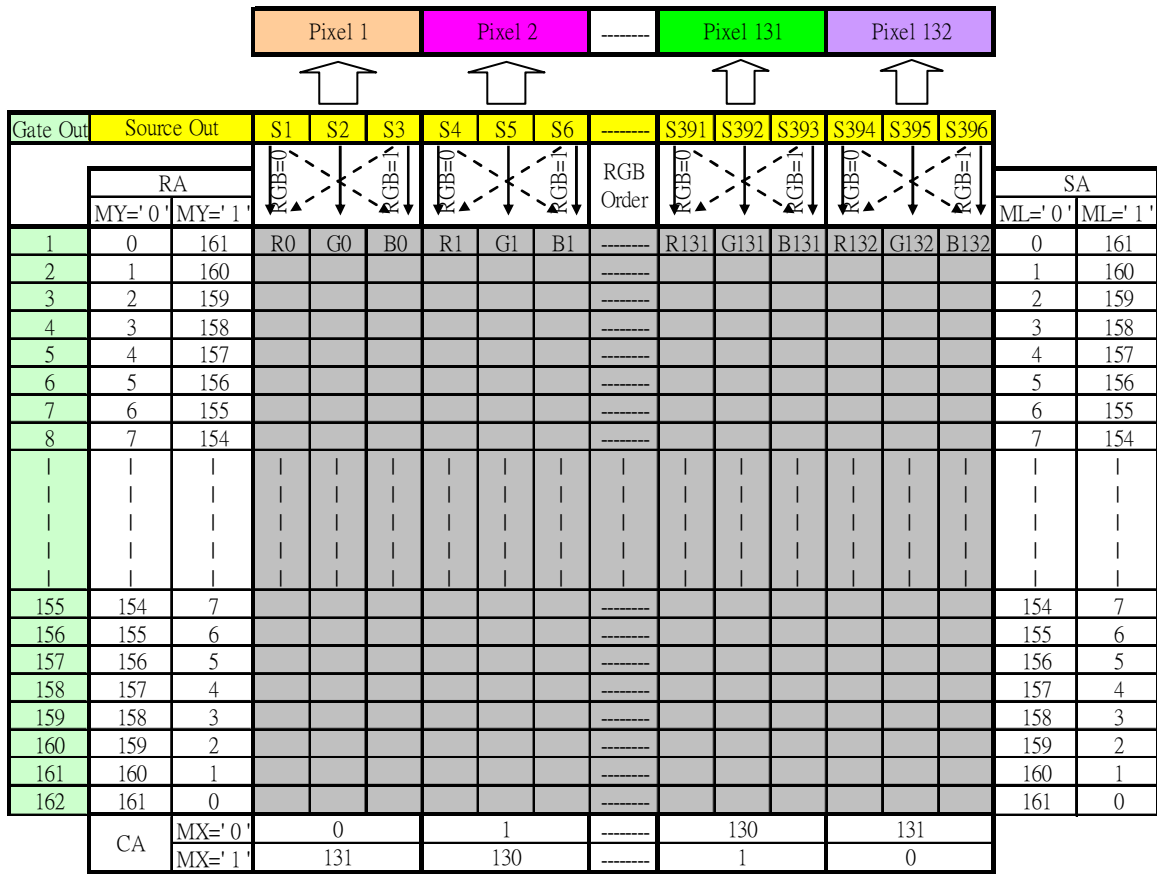

Note

RA = Row Address,

CA = Column Address

SA = Scan Address

MX = Mirror X-axis (Column address direction parameter), D6 parameter of MADCTL command

MY = Mirror Y-axis (Row address direction parameter), D7 parameter of MADCTL command

ML = Scan direction parameter, D4 parameter of MADCTL command

RGB = Red, Green and Blue pixel position change, D3 parameter of MADCTL command

9.9.6 Normal Display On or Partial Mode On

9.9.7 When using 128RGB x 160 resolution (GM[1:0] = "11")

In this mode, the content of the frame memory within an area where column pointer is 00h to 7Fh and page pointer is 00h to 9Fh is displayed. To display a dot on leftmost top corner, store the dot data at (column pointer, row pointer) = (0, 0).

1). Example for Normal Display On (MX=MY=ML='0', SMX=SMY='0')

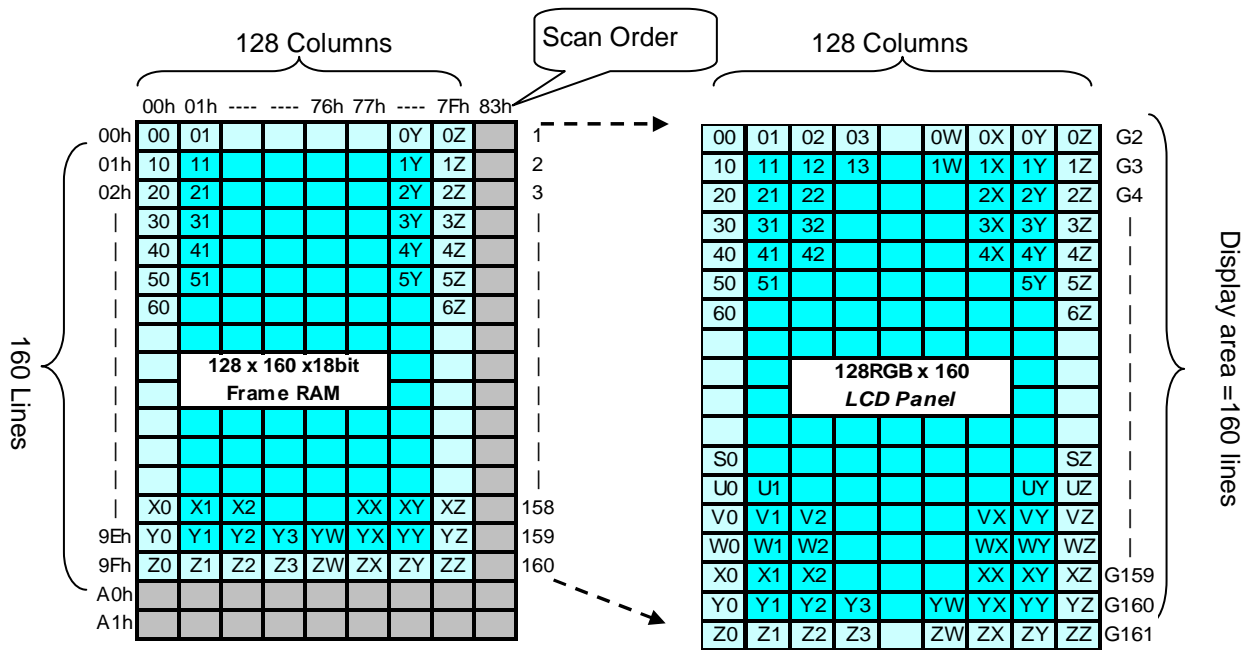

2). Example for Partial Display On (PSL[7:0]=04h, PEL[7:0]=9Bh, MX=MV=ML='0', SMX=SMY='0')

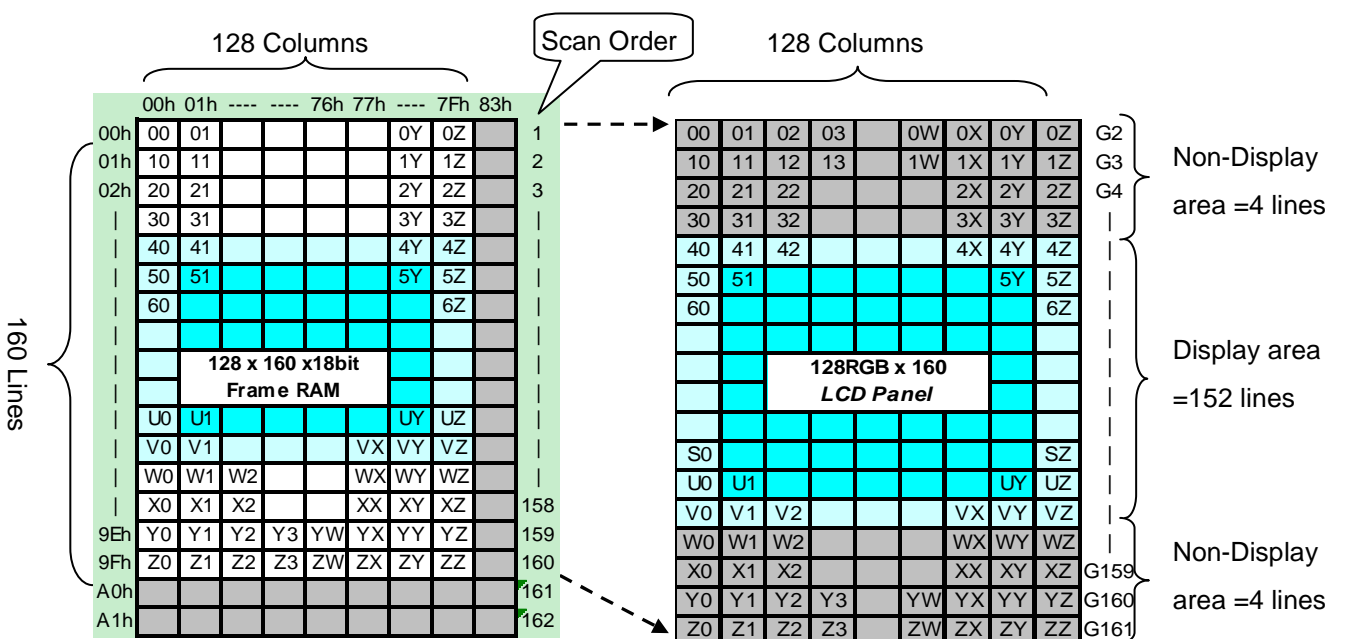

9.9.8 When using 128RGB x 160 resolution (GM[1:0] = "01")

In this mode, the content of the frame memory within an area where column pointer is 00h to 83h and page pointer is 00h to 83h is displayed. To display a dot on leftmost top corner, store the dot data at (column pointer, row pointer) = (0, 0).

1). Example for Normal Display On (MX=MY=ML='0', SMX=SMY='0')

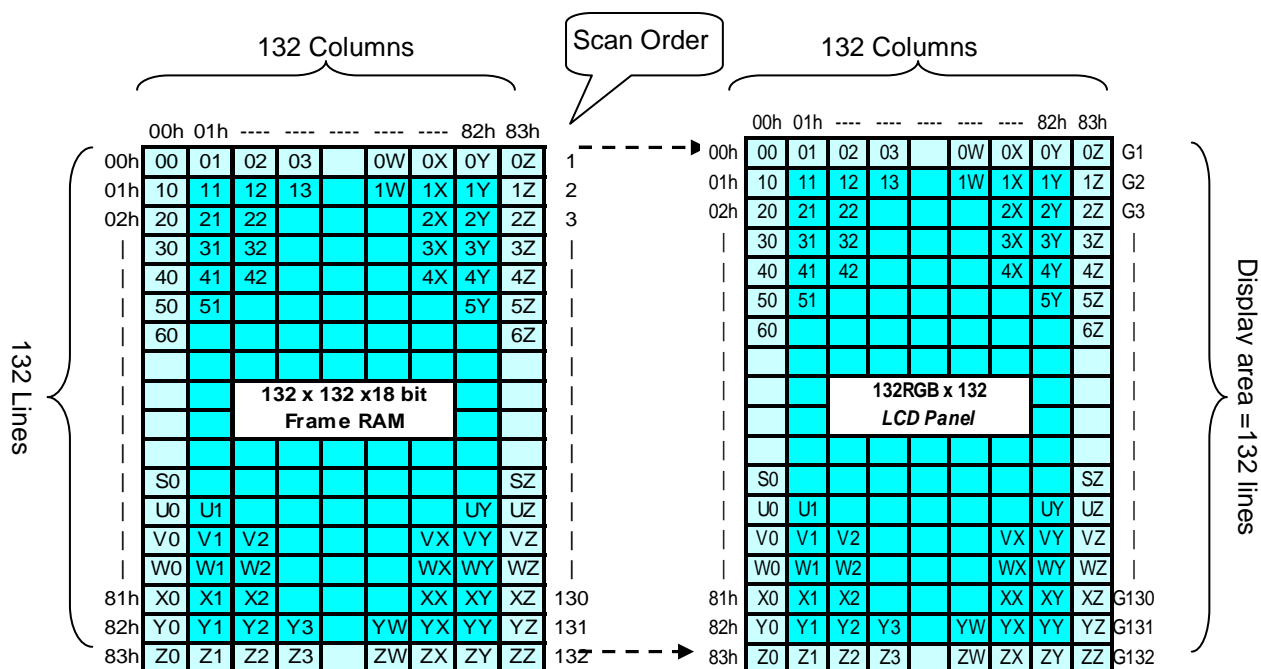

2). Example for Partial Display On (PSL[7:0]=00h, PEL[7:0]=83h, MX=MV=ML='0', SMX=SMY='0')

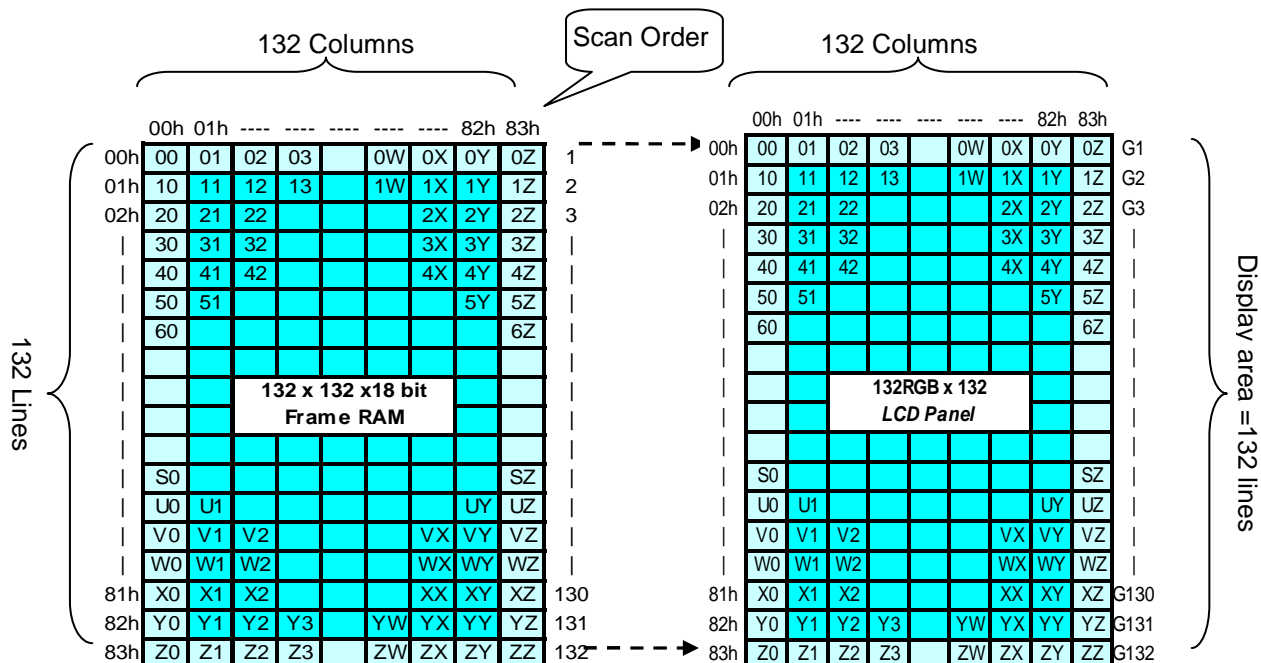

9.9.9 When using 132RGB x 162 resolution (GM[1:0] = "00")

In this mode, contents of the frame memory within an area where column pointer is 00h to 83h and page pointer is 00h to A1h is displayed. To display a dot on leftmost top corner, store the dot data at (column pointer, row pointer) = (0, 0)

1). Example for Normal Display On (MX=MY=ML='0', SMX=SMY='0')

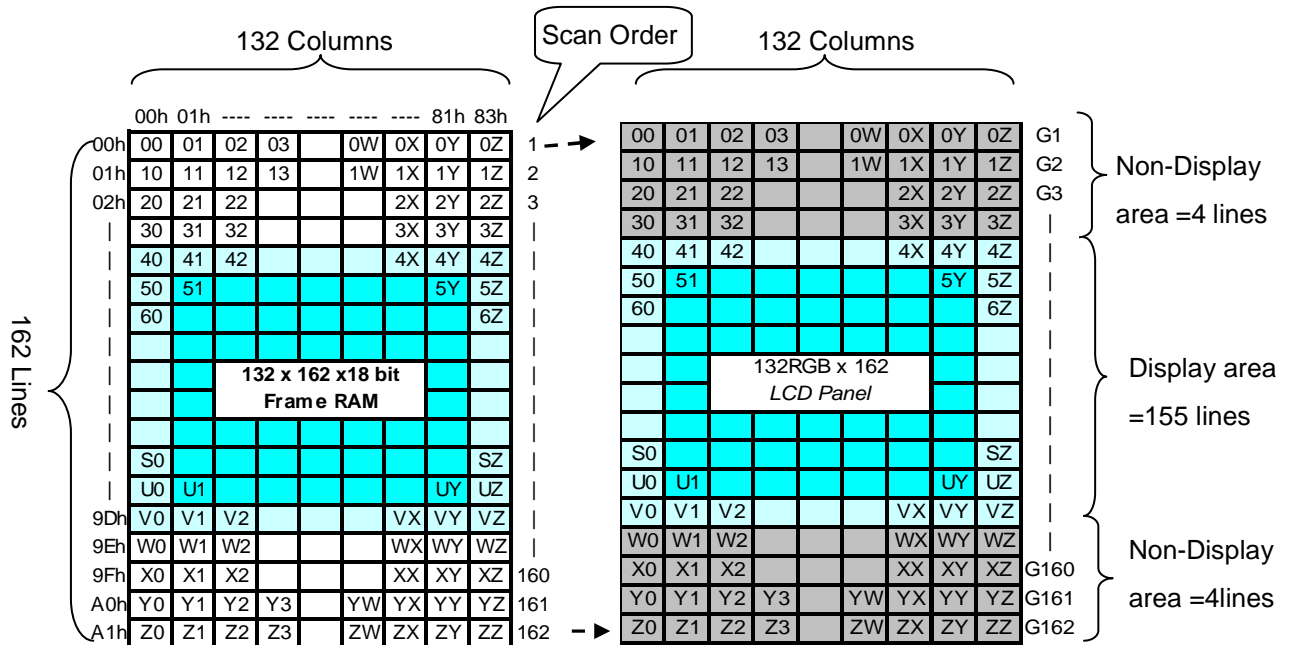

2). Example for Partial Display On (PSL[7:0]=04h, PEL[7:0]=9Dh, MX=MV=ML='0', SMX=SMY='0')

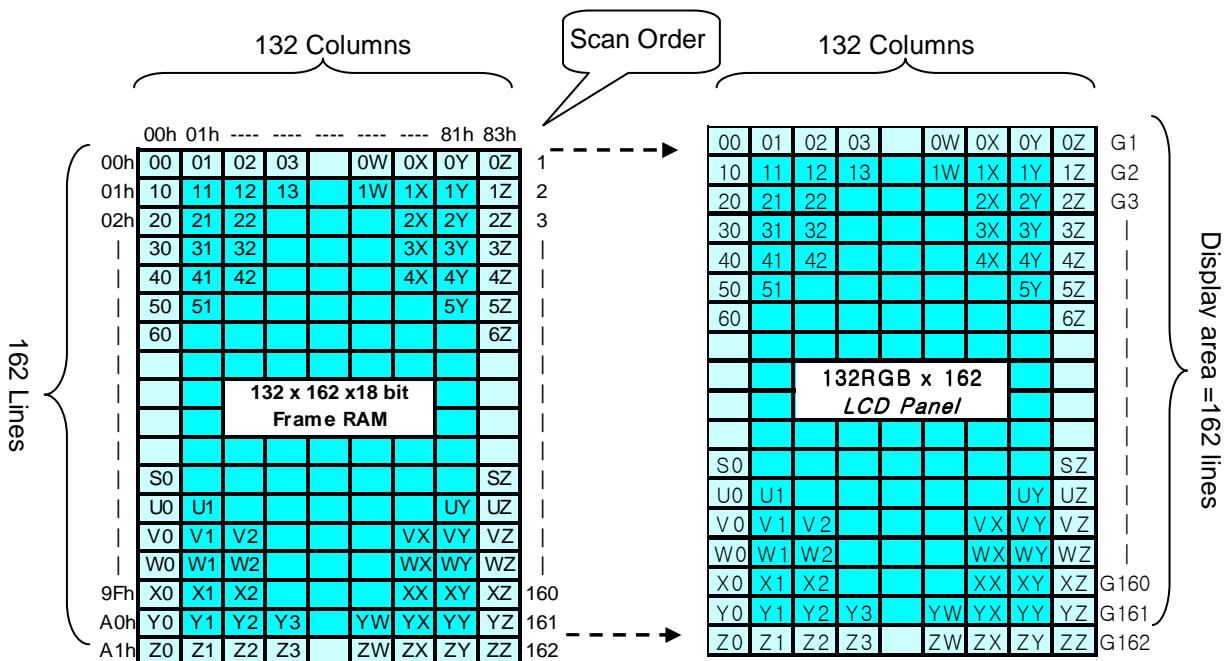

9.10 Address Counter

The address counter sets the addresses of the display data RAM for writing and reading.

Data is written pixel-wise into the RAM matrix of DRIVER. The data for one pixel or two pixels is collected (RGB 6-6-6-bit), according to the data formats. As soon as this pixel-data information is complete the “Write access” is activated on the RAM. The locations of RAM are addressed by the address pointers. The address ranges are X=0 to X=131 (83h) and Y=0 to Y=161 (A1h). Addresses outside these ranges are not allowed. Before writing to the RAM, a window must be defined that will be written. The window is programmable via the command registers XS, YS designating the start address and XE, YE designating the end address.

For example the whole display contents will be written, the window is defined by the following values: XS=0 (0h) YS=0 (0h) and XE=127 (83h), YE=161 (A1h).

In vertical addressing mode (MV=1), the Y-address increments after each byte, after the last Y-address (Y=YE), Y wraps around to YS and X increments to address the next column. In horizontal addressing mode (V=0), the X-address increments after each byte, after the last X-address (X=XE), X wraps around to XS and Y increments to address the next row. After the every last address (X=XE and Y=YE) the address pointers wrap around to address (X=XS and Y=YS).

For flexibility in handling a wide variety of display architectures, the commands “CASET, RASET and MADCTL” (see section 10 command list), define flags MX and MY, which allows mirroring of the X-address and Y-address. All combinations of flags are allowed. Section 9.10 show the available combinations of writing to the display RAM. When MX, MY and MV will be changed the data must be rewritten to the display RAM.

For each image condition, the controls for the column and row counters apply as section 9.11 below

| Condition | Column Counter | Row Counter |
|---|-------------------------------|----------------------------|
| When RAMWR/RAMRD command is accepted | Return to “Start Column (XS)” | Return to “Start Row (YS)” |
| Complete Pixel Read / Write action | Increment by 1 | No change |
| The Column counter value is larger than “End Column (XE)” | Return to “Start Column (XS)” | Increment by 1 |
| The Column counter value is larger than “End Column (XE)” and the Row counter value is larger than “End Row (YE)” | Return to “Start Column (XS)” | Return to “Start Row (YS)” |

9.11 Memory Data Write/ Read Direction

The data is written in the order illustrated above. The Counter which dictates where in the physical memory the data is to be written is controlled by “Memory Data Access Control” Command, bits B5 (MV), B6 (MX), B7 (MY) as described below.

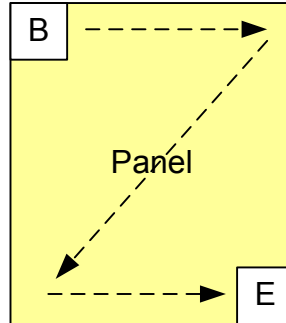

Figure 28 Data Streaming order

9.11.1 When 128RGBx160 (GM= “11”)

| MV | MX | MY | CASET | RASET |
|----|----|----|---|---|
| 0 | 0 | 0 | Direct to Physical Column Pointer | Direct to Physical Row Pointer |
| 0 | 0 | 1 | Direct to Physical Column Pointer | Direct to (159-Physical Row Pointer) |
| 0 | 1 | 0 | Direct to (127-Physical Column Pointer) | Direct to Physical Row Pointer |
| 0 | 1 | 1 | Direct to (127-Physical Column Pointer) | Direct to (159-Physical Row Pointer) |
| 1 | 0 | 0 | Direct to Physical Row Pointer | Direct to Physical Column Pointer |
| 1 | 0 | 1 | Direct to (159-Physical Row Pointer) | Direct to Physical Column Pointer |
| 1 | 1 | 0 | Direct to Physical Row Pointer | Direct to (127-Physical Column Pointer) |
| 1 | 1 | 1 | Direct to (159-Physical Row Pointer) | Direct to (127-Physical Column Pointer) |

9.11.2 When 132RGBx132 (GM= “01”)

| MV | MX | MY | CASET | RASET |
|----|----|----|---|---|
| 0 | 0 | 0 | Direct to Physical Column Pointer | Direct to Physical Row Pointer |
| 0 | 0 | 1 | Direct to Physical Column Pointer | Direct to (131-Physical Row Pointer) |
| 0 | 1 | 0 | Direct to (131-Physical Column Pointer) | Direct to Physical Row Pointer |
| 0 | 1 | 1 | Direct to (131-Physical Column Pointer) | Direct to (131-Physical Row Pointer) |
| 1 | 0 | 0 | Direct to Physical Row Pointer | Direct to Physical Column Pointer |
| 1 | 0 | 1 | Direct to (131-Physical Row Pointer) | Direct to Physical Column Pointer |
| 1 | 1 | 0 | Direct to Physical Row Pointer | Direct to (131-Physical Column Pointer) |
| 1 | 1 | 1 | Direct to (131-Physical Row Pointer) | Direct to (131-Physical Column Pointer) |

9.11.3 When 132RGBx162 (GM= "00")

| MV | MX | MY | CASET | RASET |
|----|----|----|---|---|
| 0 | 0 | 0 | Direct to Physical Column Pointer | Direct to Physical Row Pointer |
| 0 | 0 | 1 | Direct to Physical Column Pointer | Direct to (161-Physical Row Pointer) |
| 0 | 1 | 0 | Direct to (131-Physical Column Pointer) | Direct to Physical Row Pointer |
| 0 | 1 | 1 | Direct to (131-Physical Column Pointer) | Direct to (161-Physical Row Pointer) |
| 1 | 0 | 0 | Direct to Physical Row Pointer | Direct to Physical Column Pointer |
| 1 | 0 | 1 | Direct to (161-Physical Row Pointer) | Direct to Physical Column Pointer |
| 1 | 1 | 0 | Direct to Physical Row Pointer | Direct to (131-Physical Column Pointer) |
| 1 | 1 | 1 | Direct to (161-Physical Row Pointer) | Direct to (131-Physical Column Pointer) |

Note: Data is always written to the Frame Memory in the same order, regardless of the Memory Write Direction set by MADCTL bits B7 (MY), B6 (MX), B5 (MV). The write order for each pixel unit is

| | | | | | | | | | | | | | | | | | |
|-----|-----|-----|-----|-----|-----|-----|-----|----|----|----|----|----|----|----|----|----|----|
| D17 | D16 | D15 | D14 | D13 | D12 | D11 | D10 | D9 | D8 | D7 | D6 | D5 | D4 | D3 | D2 | D1 | D0 |
| R5 | R4 | R3 | R2 | R1 | R0 | G5 | G4 | G3 | G2 | G1 | G0 | B5 | B4 | B3 | B2 | B1 | B0 |

One pixel unit represents 1 column and 1page counter value on the Frame Memory.

9.11.4 Frame Data Write Direction According to the MADCTL Parameters (MV, MX and MY)

| Display Data Direction | MADCTL Parameter | | | Image in the Host (MPU) | Image in the Driver (DDRAM) |
|--------------------------|------------------|----|----|-------------------------|-----------------------------|
| | MV | MX | MY | | |
| Normal | 0 | 0 | 0 | | |
| Y-Mirror | 0 | 0 | 1 | | |
| X-Mirror | 0 | 1 | 0 | | |
| X-Mirror Y-Mirror | 0 | 1 | 1 | | |
| X-Y Exchange | 1 | 0 | 0 | | |
| X-Y Exchange Y-Mirror | 1 | 0 | 1 | | |
| X-Y Exchange X-Mirror | 1 | 1 | 0 | | |

| | | | | | |
|--------------|---|---|---|--|--|
| X-Y Exchange | | | | | |
| X-Mirror | 1 | 1 | 1 | | |
| Y-Mirror | | | | | |

9.11.5 Scroll Address Circuit

The circuit associates lines on DDRAM with Gate output. ST7735S processes signals for the liquid crystal display on 1-line basis. Thus, when specifying a specific area in the area scroll display or partial display, you must designate it in line.

9.11.6 Vertical Scroll Mode

There is just one types of vertical scrolling, which are determined by the commands “Vertical Scrolling Definition” (33h) and “Vertical Scrolling Start Address” (37h)

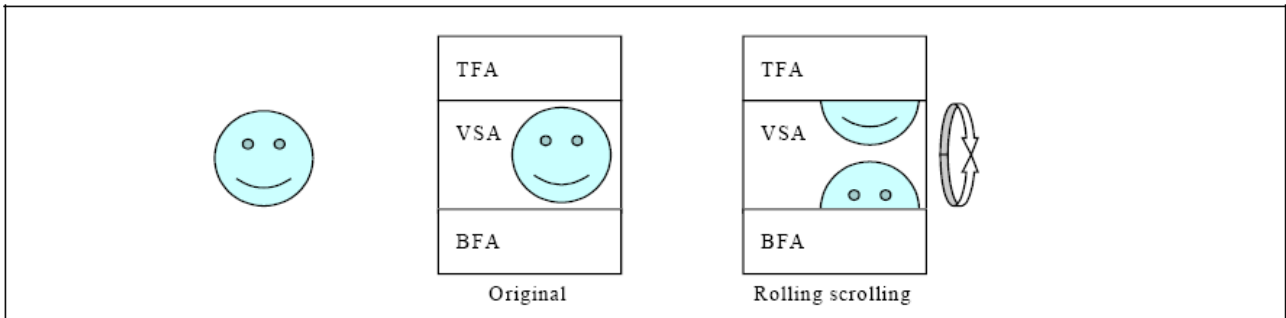

When Vertical Scrolling Definition Parameters (TFA+VSA+BFA) =162. In this case, ‘rolling’ scrolling is applied as shown below. All the memory contents will be used.

Example 1) Panel size=132(RGB) x 162, TFA =3, VSA=157, BFA=2, SSA=6, MADCTR (ML) =0: Rolling Scroll

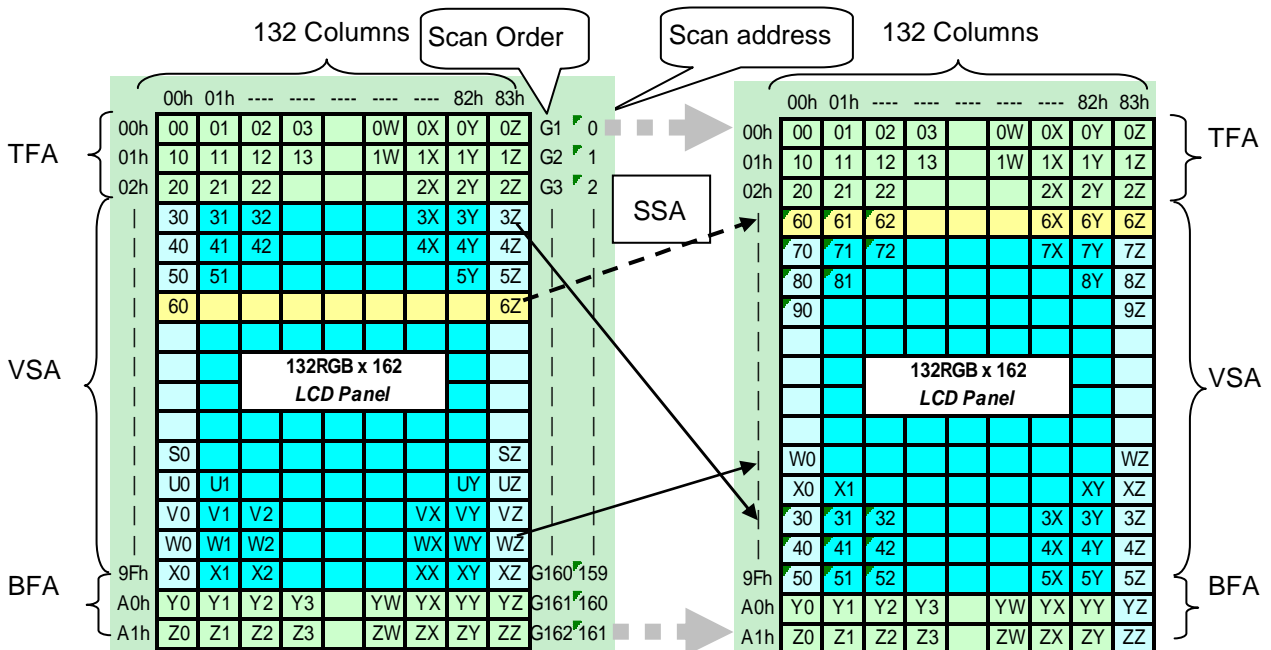

Example 2) Panel size=132(RGB) x 162, TFA =3, VSA=157, BFA=2, SSA=6, MADCTR (ML) =1: Rolling Scroll.

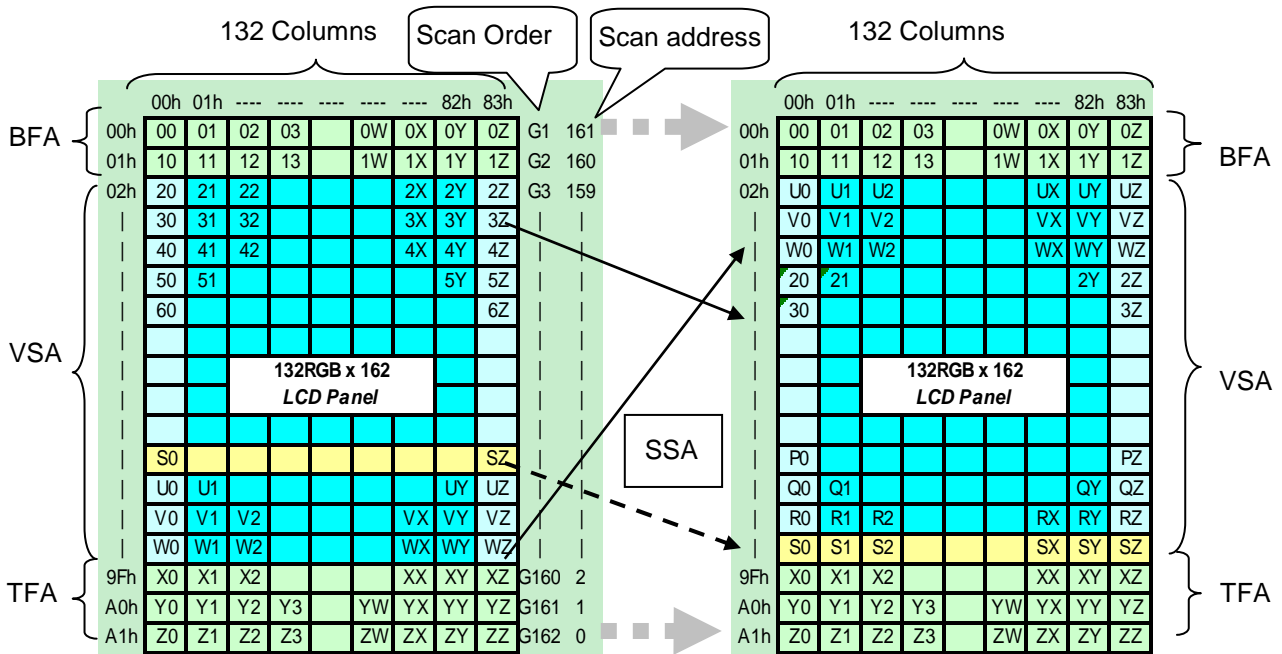

9.11.7 Vertical Scroll Example

There are 2 types of vertical scrolling, which are determined by the commands "Vertical Scrolling Definition" (33h) and "Vertical Scrolling Start Address" (37h).

9.11.8 Case 1: TFA + VSA + BFA < 162

N/A. Do not set TFA + VSA + BFA < 162. In that case, unexpected picture will be shown.

9.11.9 Case 2: TFA + VSA + BFA=162 (Rolling Scrolling)

Example 2-a) When MADCTR parameter ML="0", TFA=0, VSA=162, BFA=0 and VSCSAD=40

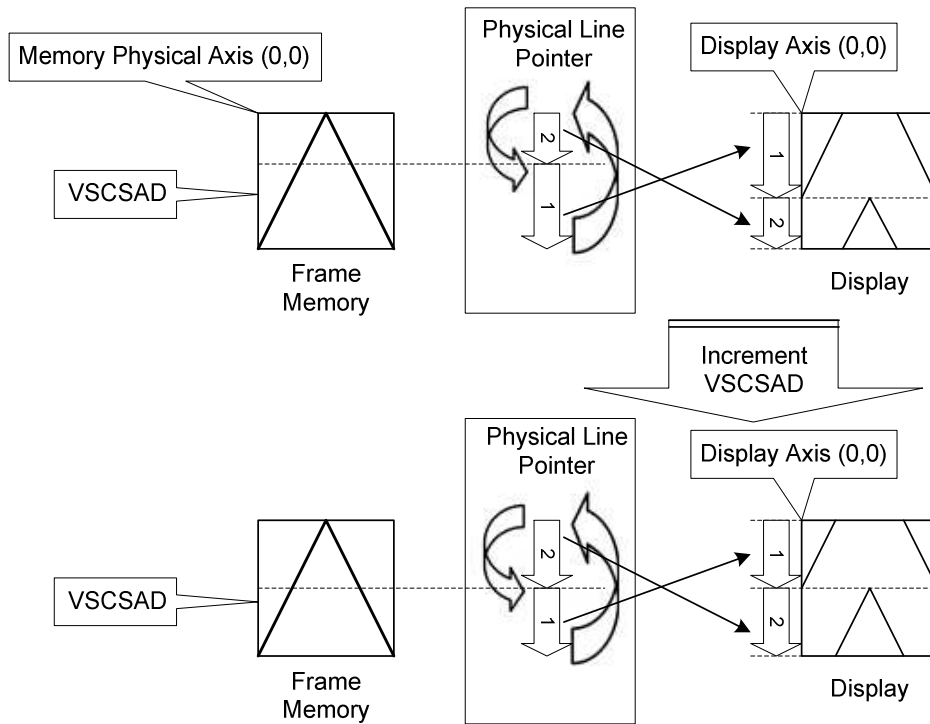

Example 2-b) When MADCTR parameter ML="1", TFA=10, VSA=152, BFA=0 and VSCSAD=30

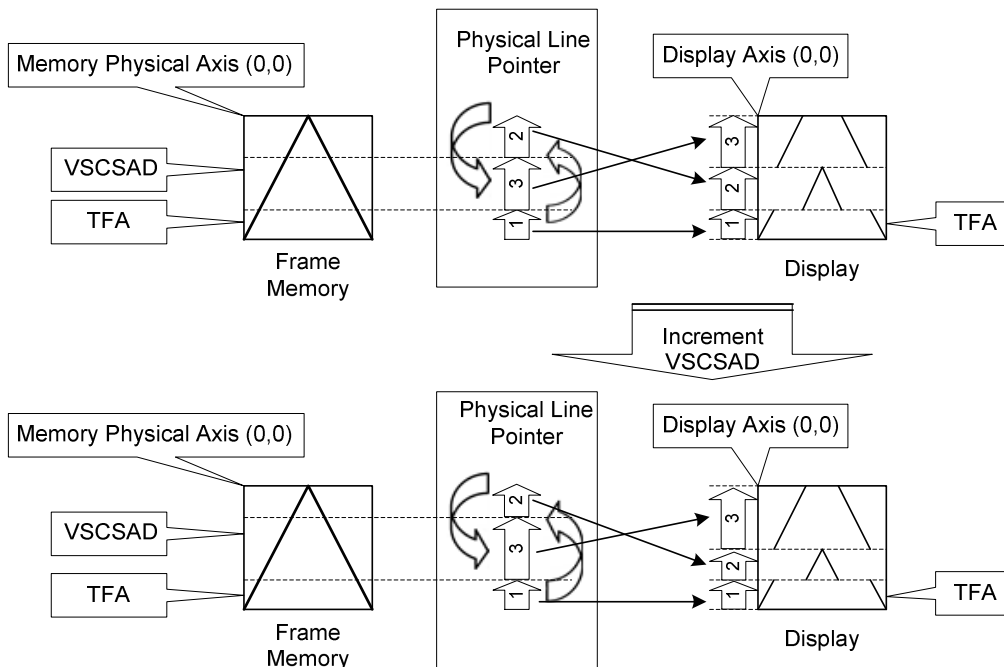

9.12 Tearing Effect Output Line

The Tearing Effect output line supplies to the MPU a Panel synchronization signal. This signal can be enabled or disabled by the Tearing Effect Line Off & On commands. The mode of the Tearing Effect signal is defined by the parameter of the Tearing Effect Line On command. The signal can be used by the MPU to synchronize Frame Memory Writing when displaying video images.

9.12.1 Tearing Effect Line Modes

Mode 1, the Tearing Effect Output signal consists of V-Blanking Information only:

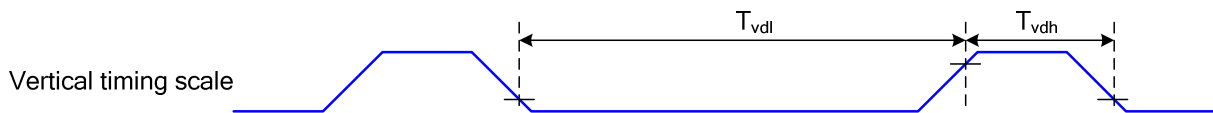

tvdh= The LCD display is not updated from the Frame Memory

tvdl= The LCD display is updated from the Frame Memory (except Invisible Line – see above)

Mode 2, the Tearing Effect Output signal consists of V-Blanking and H-Blanking Information, there is one V-sync and 162 H-sync pulses per field.

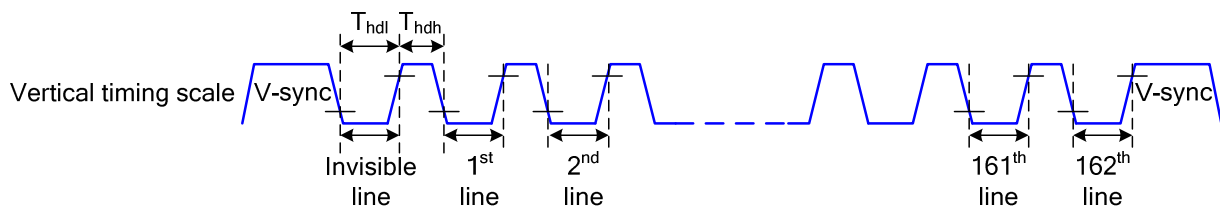

thdh= The LCD display is not updated from the Frame Memory

thdl= The LCD display is updated from the Frame Memory (except Invisible Line – see above)

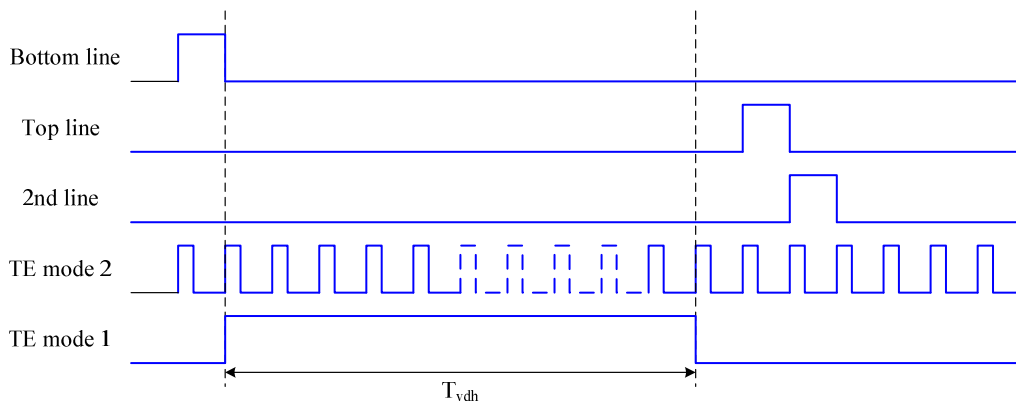

Note: During Sleep In Mode, the Tearing Output Pin is active Low.

9.12.2 Tearing Effect Line Timings

The Tearing Effect signal is described below:

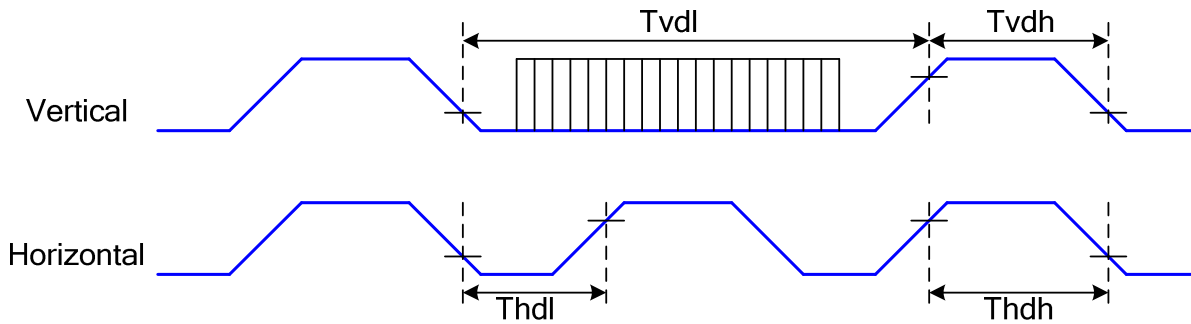

| Symbol | Parameter | min | max | unit | description |
|--------|--------------------------------|------|-----|------|-------------|
| tvdl | Vertical Timing Low Duration | 13 | - | ms | |
| tvdh | Vertical Timing High Duration | 1000 | - | μs | |
| thdl | Horizontal Timing Low Duration | 33 | - | μs | |
| thdh | Horizontal Timing Low Duration | 25 | 500 | μs | |

Table 13 AC characteristics of Tearing Effect Signal Idle Mode Off (Frame Rate = 60 Hz, Ta=25°C)

Note: The timings in Table 9.10.1 apply when MADCTL ML=0 and ML=1

The signal's rise and fall times (tf, tr) are stipulated to be equal to or less than 15ns.

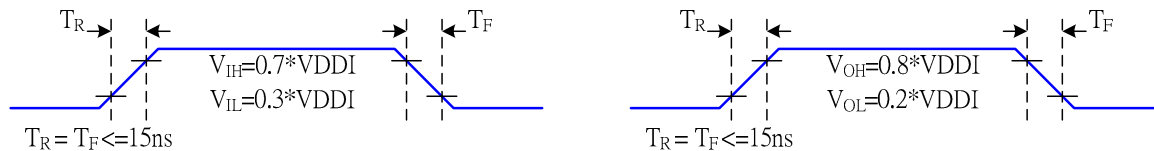

The Tearing Effect Output Line is fed back to the MPU and should be used as shown below to avoid Tearing Effect:

9.12.3 Example 1: MPU Write is faster than panel read

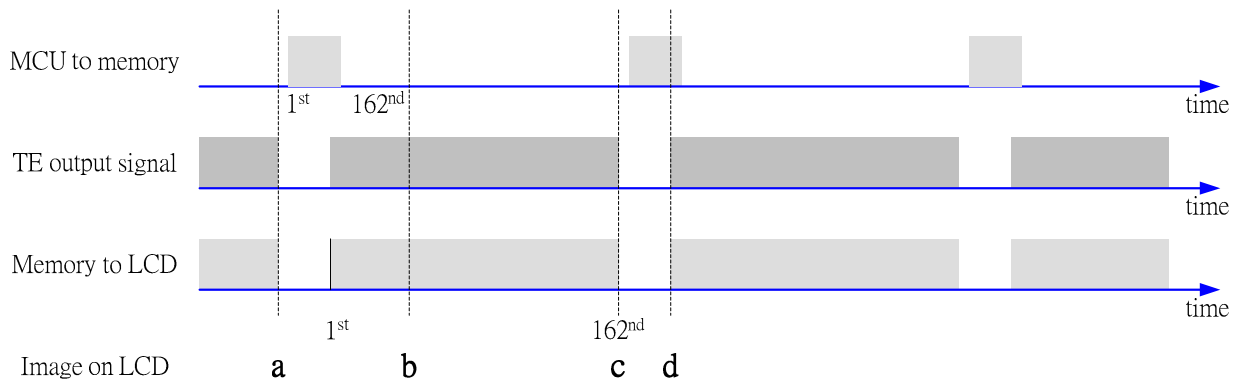

Data write to Frame Memory is now synchronized to the Panel Scan. It should be written during the vertical sync pulse of the Tearing Effect Output Line. This ensures that data is always written ahead of the panel scan and each Panel Frame refresh has a complete new image:

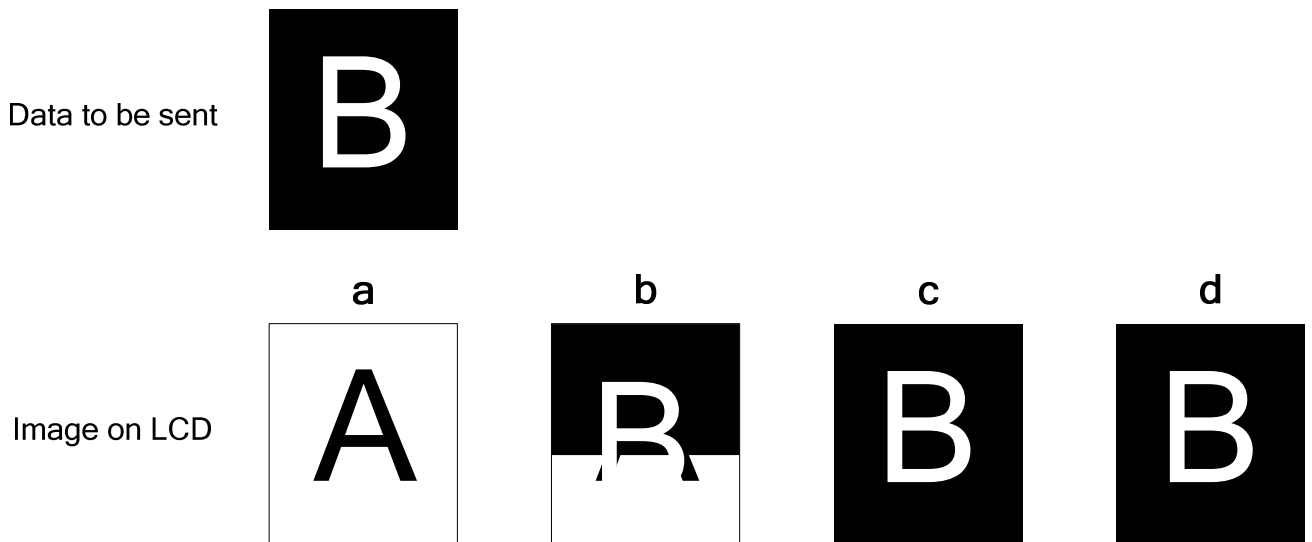

9.12.4 Example 2: MPU Write is slower than panel read

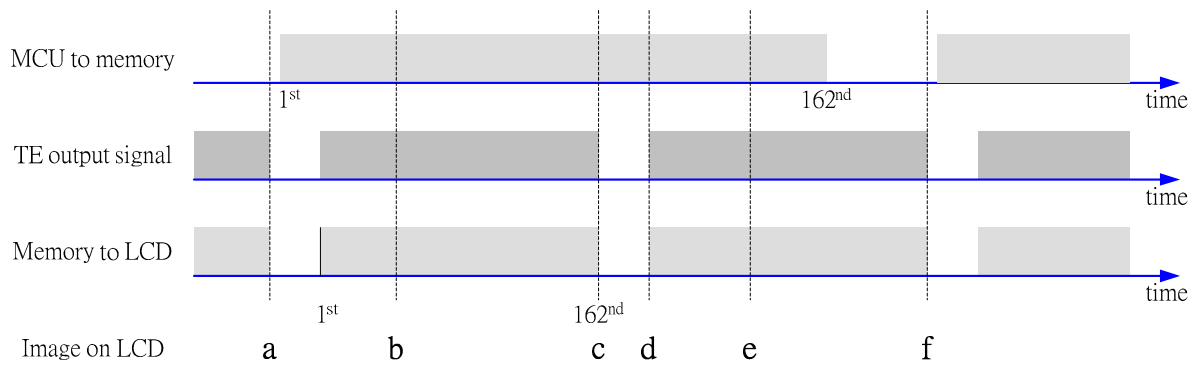

The MPU to Frame Memory write begins just after Panel Read has commenced i.e. after one horizontal sync pulse of the Tearing Effect Output Line. This allows time for the image to download behind the Panel Read pointer and finishing download during the subsequent Frame before the Read Pointer “catches” the MPU to Frame memory write position.

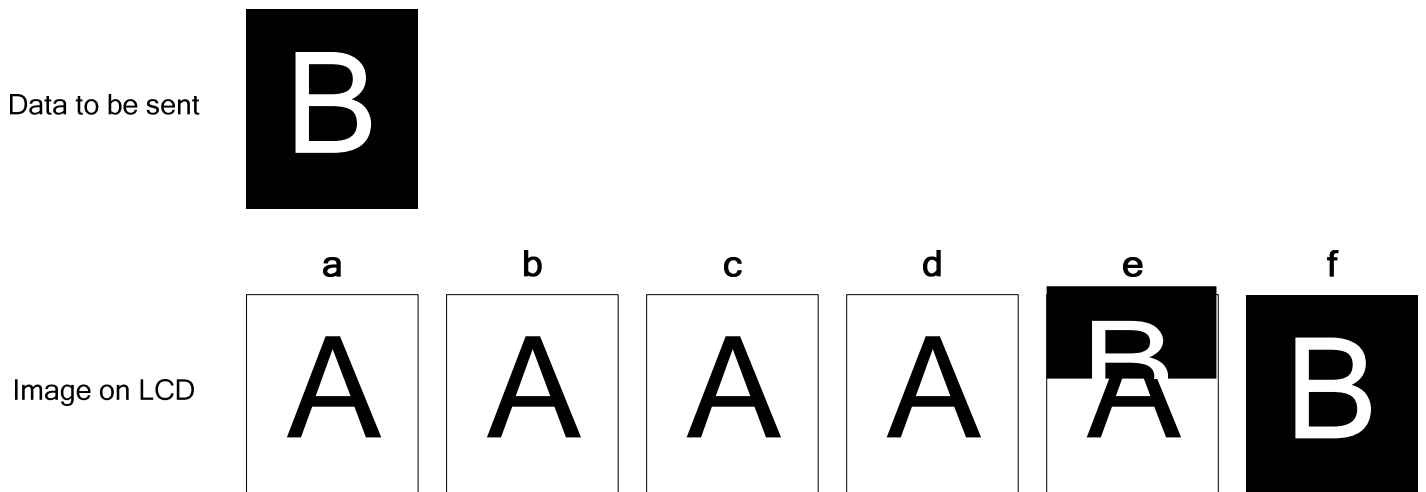

9.13 Power ON/OFF Sequence

VDDI and VDD can be applied in any order

VDD and VDDI can be powered down in any order

During power off, if LCD is in the Sleep Out mode, VDD and VDDI must be powered down minimum 120msec after RESX has been released.

During power off, if LCD is in the Sleep In mode, VDDI or VDD can be powered down minimum 0msec after RESX has been released.

CSX can be applied at any timing or can be permanently grounded. RESX has priority over CSX.

Note 1: There will be no damage to the display module if the power sequences are not met.

Note 2: There will be no abnormal visible effects on the display panel during the Power On/Off Sequences.

Note 3: There will be no abnormal visible effects on the display between end of Power On Sequence and before receiving Sleep Out command. Also between receiving Sleep In command and Power Off Sequence.

Note 4: If RESX line is not held stable by host during Power On Sequence as defined in the sequence below, then it will be necessary to apply a Hardware Reset (RESX) after Host Power On Sequence is complete to ensure correct operation. Otherwise function is not guaranteed.

The power on/off sequence is illustrated below

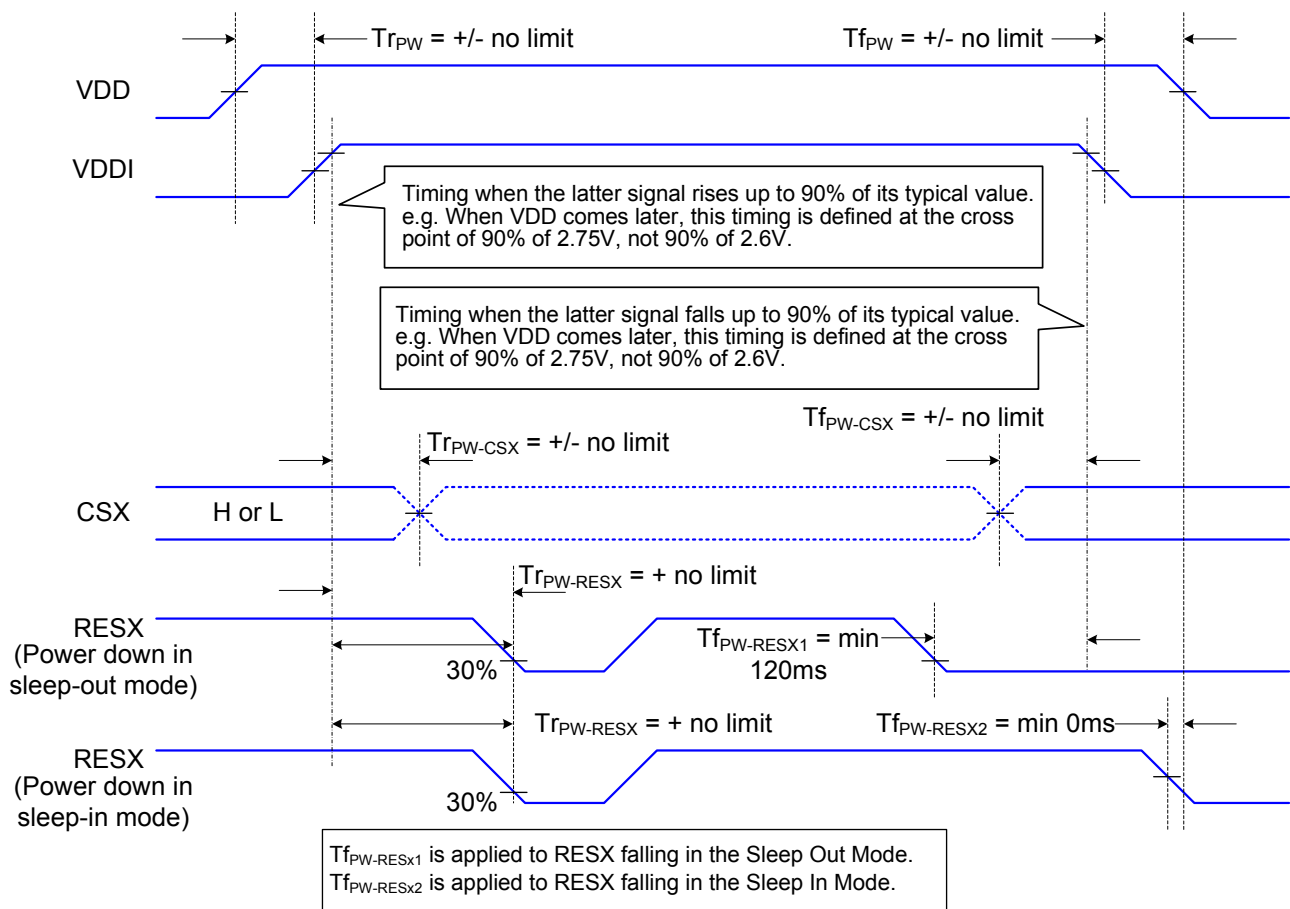

9.13.1 Uncontrolled Power Off

The uncontrolled power-off means a situation which removed a battery without the controlled power off sequence. It will neither damage the module or the host interface.

If uncontrolled power-off happened, the display will go blank and there will not any visible effect on the display (blank display) and remains blank until "Power On Sequence" powers it up.

9.14 Power Level Definition

9.14.1 Power Level

6 level modes are defined they are in order of Maximum Power consumption to Minimum Power Consumption

1. Normal Mode On (full display), Idle Mode Off, Sleep Out.

In this mode, the display is able to show maximum 262,144 colors.

2. Partial Mode On, Idle Mode Off, Sleep Out.

In this mode part of the display is used with maximum 262,144 colors.

3. Normal Mode On (full display), Idle Mode On, Sleep Out.

In this mode, the full display area is used but with 8 colors.

4. Partial Mode On, Idle Mode On, Sleep Out.

In this mode, part of the display is used but with 8 colors.

5. Sleep In Mode

In this mode, the DC: DC converter, internal oscillator and panel driver circuit are stopped. Only the MCU interface and memory works with VDDI power supply. Contents of the memory are safe.

6. Power Off Mode

In this mode, both VDD and VDDI are removed.

Note: Transition between modes 1-5 is controllable by MCU commands. Mode 6 is entered only when both Power supplies are removed.

9.14.2 Power Flow Chart

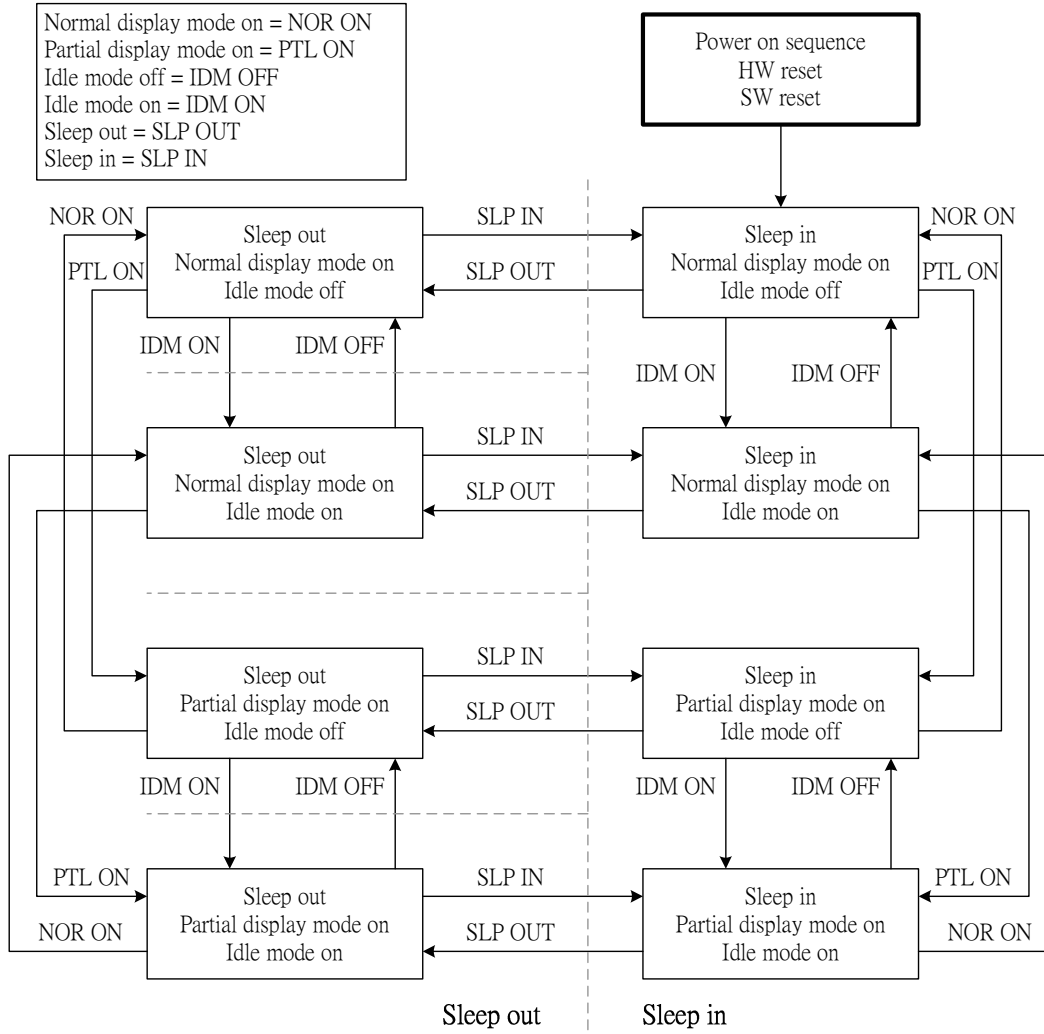

9.15 Reset Table

9.15.1 Reset Table(Default Value, GM[1:0]="11", 128RGB x 160)

| Item | After Power On | After H/W Reset | After S/W Reset |
|---|------------------|------------------|--|
| Frame Memory | Random | No Change | No Change |
| Sleep In/Out | In | In | In |
| Display On/Off | Off | Off | Off |
| Display Mode (Normal/Partial) | Normal | Normal | Normal |
| Display Inversion On/Off | Off | Off | Off |
| Display Idle Mode On/Off | Off | Off | Off |
| Column: Start Address (XS) | 0000h | 0000h | 0000h |
| Column: End Address (XE) | 007Fh | 007Fh | 007Fh (127d) (when MV=0) 009Fh (159d) (when MV=1) |
| Row: Start Address (YS) | 0000h | 0000h | 0000h |
| Row: End Address (YE) | 009Fh | 009Fh | 009Fh (159d) (when MV=0) 007Fh (127d) (when MV=1) |
| Gamma setting | GC0 | GC0 | GC0 |
| RGB for 4k and 65k Color Mode | Random values | Random values | No Change |
| Partial: Start Address (PSL) | 0000h | 0000h | 0000h |
| Partial: End Address (PEL) | 009Fh | 009Fh | 009Fh |
| Scroll: Top Fixed Area (TFA) | 0000h | 0000h | 0000h |
| Scroll: Scroll Area (VSA) | 00A0h | 00A0h | 00A0h |
| Scroll: Bottom Fixed Area (BFA) | 0000h | 0000h | 0000h |
| Scroll Start Address (SSA) | 0000h | 0000h | 0000h |
| Tearing: On/Off | Off | Off | Off |
| Tearing Effect Mode (*1) | 0 (Mode1) | 0 (Mode1) | 0 (Mode1) |
| Memory Data Access Control (MY/MX/MV/ML/RGB) | 0/0/0/0/0 | 0/0/0/0/0 | No Change |
| Interface Pixel Color Format | 6 (18-Bit/Pixel) | 6 (18-Bit/Pixel) | No Change |
| RDDPM | 08h | 08h | 08h |
| RDDMADCTL | 00h | 00h | No Change |
| RDDCOLMOD | 6 (18-Bit/Pixel) | 6 (18-Bit/Pixel) | No Change |
| RDDIM | 00h | 00h | 00h |
| RDDSM | 00h | 00h | 00h |
| ID2 | NV value | NV value | NV value |
| ID3 | NV value | NV value | NV value |

Note: TE Mode 1 means Tearing Effect Output Line consists of V-Blanking Information only

9.15.2 Reset Table (GM[1:0]= "01", 132RGB x 132)

| Item | After Power On | After H/W Reset | After S/W Reset |
|---|------------------|------------------|--|
| Frame memory | Random | No Change | No Change |
| Sleep In/Out | In | In | In |
| Display On/Off | Off | Off | Off |
| Display Mode (Normal/Partial) | Normal | Normal | Normal |
| Display Inversion On/Off | Off | Off | Off |
| Display Idle Mode On/Off | Off | Off | Off |
| Column: Start Address (XS) | 0000h | 0000h | 0000h |
| Column: End Address (XE) | 0083h | 0083h | 0083h (131d) (when MV=0) 0083h (131d) (when MV=1) |
| Row: Start Address (YS) | 0000h | 0000h | 0000h |
| Row: End Address (YE) | 0083h | 0083h | 0083h (131d) (when MV=0) 0083h (131d) (when MV=1) |
| Gamma Setting | GC0 | GC0 | GC0 |
| RGB for 4k and 65k Color Mode | See Section 9.17 | See Section 9.17 | No Change |
| Partial: Start Address (PSL) | 0000h | 0000h | 0000h |
| Partial: End Address (PEL) | 0083h | 0083h | 0083h |
| Tearing: On/Off | Off | Off | Off |
| Scroll: Top Fixed Area (TFA) | 0000h | 0000h | 0000h |
| Scroll: Scroll Area (VSA) | 0084h | 0084h | 0084h |
| Scroll: Bottom Fixed Area (BFA) | 0000h | 0000h | 0000h |
| Scroll Start Address (SSA) | 0000h | 0000h | 0000h |
| Tearing Effect Mode (*1) | 0 (Mode1) | 0 (Mode1) | 0 (Mode1) |
| Memory Data Access Control (MY/MX/MV/ML/RGB) | 0/0/0/0/0 | 0/0/0/0/0 | No Change |
| Interface Pixel Color Format | 6 (18-Bit/Pixel) | 6 (18-Bit/Pixel) | No Change |
| RDDPM | 08h | 08h | 08h |
| RDDMADCTL | 00h | 00h | No Change |
| RDDCOLMOD | 6 (18-Bit/Pixel) | 6 (18-Bit/Pixel) | No Change |
| RDDIM | 00h | 00h | 00h |
| RDDSM | 00h | 00h | 00h |
| ID2 | NV value | NV value | NV value |
| ID3 | NV value | NV value | NV value |

Note: TE Mode 1 means Tearing Effect Output Line consists of V-Blanking Information only

9.15.3 Reset Table (GM[1:0]= "00", 132RGB x 162)

| Item | After Power On | After H/W Reset | After S/W Reset |
|---|------------------|------------------|--|
| Frame memory | Random | No Change | No Change |
| Sleep In/Out | In | In | In |
| Display On/Off | Off | Off | Off |
| Display mode (normal/partial) | Normal | Normal | Normal |
| Display Inversion On/Off | Off | Off | Off |
| Display Idle Mode On/Off | Off | Off | Off |
| Column: Start Address (XS) | 0000h | 0000h | 0000h |
| Column: End Address (XE) | 0083h | 0083h | 0083h (131d) (when MV=0) 00A1h (161d) (when MV=1) |
| Row: Start Address (YS) | 0000h | 0000h | 0000h |
| Row: End Address (YE) | 00A1h | 00A1h | 00A1h (161d) (when MV=0) 0083h (131d) (when MV=1) |
| Gamma setting | GC0 | GC0 | GC0 |
| RGB for 4k and 65k Color Mode | Random values | Random values | No Change |
| Partial: Start Address (PSL) | 0000h | 0000h | 0000h |
| Partial: End Address (PEL) | 00A2h | 00A2h | 00A2h |
| Scroll: Top Fixed Area (TFA) | 0000h | 0000h | 0000h |
| Scroll: Scroll Area (VSA) | 0084h | 0084h | 0084h |
| Scroll: Bottom Fixed Area (BFA) | 0000h | 0000h | 0000h |
| Scroll Start Address (SSA) | 0000h | 0000h | 0000h |
| Tearing: On/Off | Off | Off | Off |
| Tearing Effect Mode (*1) | 0 (Mode1) | 0 (Mode1) | 0 (Mode1) |
| Memory Data Access Control (MY/MX/MV/ML/RGB) | 0/0/0/0/0 | 0/0/0/0/0 | No Change |
| Interface Pixel Color Format | 6 (18-Bit/Pixel) | 6 (18-Bit/Pixel) | No Change |
| RDDPM | 08h | 08h | 08h |
| RDDMADCTL | 00h | 00h | No Change |
| RDDCOLMOD | 6 (18-Bit/Pixel) | 6 (18-Bit/Pixel) | No Change |
| RDDIM | 00h | 00h | 00h |
| RDDSM | 00h | 00h | 00h |
| ID2 | NV value | NV value | NV value |
| ID3 | NV value | NV value | NV value |

Note: TE Mode 1 means Tearing Effect Output Line consists of V-Blanking Information only

9.16 Module Input/Output Pins

9.16.1 Output or Bi-directional (I/O) Pins

| Output or Bi-directional pins | After Power On | After Hardware Reset | After Software Reset |
|-------------------------------|-------------------|----------------------|----------------------|
| TE | Low | Low | Low |
| D7 to D0 (Output driver) | High-Z (Inactive) | High-Z (Inactive) | High-Z (Inactive) |

| Input pins | During Power On Process | After Power On | After Hardware Reset | After Software Reset | During Power Off Process |
|------------|-------------------------|----------------|----------------------|----------------------|--------------------------|
| RESX | See 9.14 | Input valid | Input valid | Input valid | See 9.14 |
| CSX | Input invalid | Input valid | Input valid | Input valid | Input invalid |
| D/CX | Input invalid | Input valid | Input valid | Input valid | Input invalid |
| WRX | Input invalid | Input valid | Input valid | Input valid | Input invalid |
| RDX | Input invalid | Input valid | Input valid | Input valid | Input invalid |
| D7 to D0 | Input invalid | Input valid | Input valid | Input valid | Input invalid |

Note: There will be no output from D7-D0 during Power On/Off sequence, Hardware Reset and Software Reset.

9.17 Reset Timing

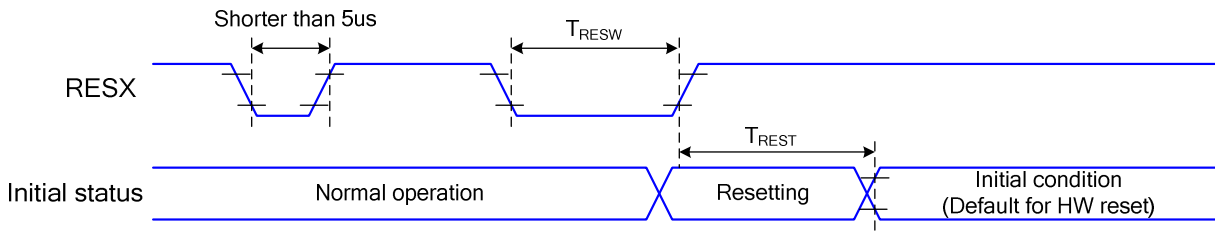

| Related Pins | Symbol | Parameter | MIN | MAX | Unit |
|--------------|--------|----------------------|-----|-----|------|
| RESX | tRESW | Reset Pulse Duration | 10 | - | us |
| | tREST | Reset Cancel | - | 5 | ms |
| | | | | 120 | ms |

Table 14 Reset Timing

Notes:

1. The reset cancel includes also required time for loading ID bytes, VCOM setting and other settings from NVM (or similar device) to registers. This loading is done every time when there is HW reset cancel time (t_{RT}) within 5 ms after a rising edge of RESX.
2. Spike due to an electrostatic discharge on RESX line does not cause irregular system reset according to the table below:

| RESX Pulse | Action |
|---------------------|----------------|
| Shorter than 5us | Reset Rejected |
| Longer than 9us | Reset |
| Between 5us and 9us | Reset Starts |

3. During the Resetting period, the display will be blanked (The display is entering blanking sequence, which maximum time is 120 ms, when Reset Starts in Sleep Out –mode. The display remains the blank state in Sleep In -mode.) and then return to Default condition for Hardware Reset.
4. Spike Rejection also applies during a valid reset pulse as shown below:

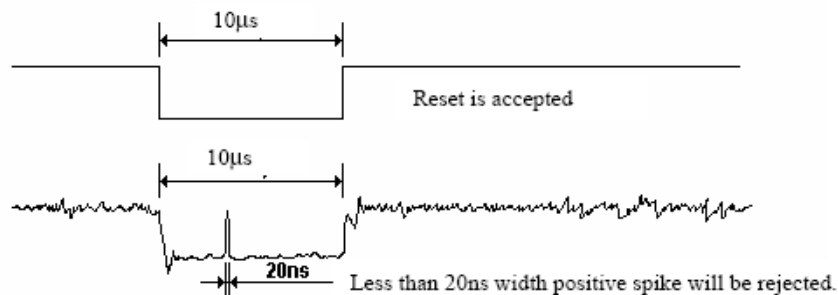

5. When Reset applied during Sleep In Mode.
6. When Reset applied during Sleep Out Mode.
7. It is necessary to wait 5msec after releasing RESX before sending commands. Also Sleep Out command cannot be sent for 120msec.

9.18 Color Depth Conversion Look Up Tables

9.18.1 65536 Color to 262,144 Color

| Color | Look Up Table Output Frame Memory Data (6-bits) | RGBSET Parameter | Look Up Table Input Data 65k Color (5-bits) |
|-------------------------------|--|-------------------------------|--|
| | RED | R005 R004 R003 R002 R001 R000 | 1 |
| R015 R014 R013 R012 R011 R010 | | 2 | 00001 |
| R025 R024 R023 R022 R021 R020 | | 3 | 00010 |
| R035 R034 R033 R032 R031 R030 | | 4 | 00011 |
| R045 R044 R043 R042 R041 R040 | | 5 | 00100 |
| R055 R054 R053 R052 R051 R050 | | 6 | 00101 |
| R065 R064 R063 R062 R061 R060 | | 7 | 00110 |
| R075 R074 R073 R072 R071 R070 | | 8 | 00111 |
| R085 R084 R083 R082 R081 R080 | | 9 | 01000 |
| R095 R094 R093 R092 R091 R090 | | 10 | 01001 |
| R105 R104 R103 R102 R101 R100 | | 11 | 01010 |
| R115 R114 R113 R112 R111 R110 | | 12 | 01011 |
| R125 R124 R123 R122 R121 R120 | | 13 | 01100 |
| R135 R134 R133 R132 R131 R130 | | 14 | 01101 |
| R145 R144 R143 R142 R141 R140 | | 15 | 01110 |
| R155 R154 R153 R152 R151 R150 | | 16 | 01111 |
| R165 R164 R163 R162 R161 R160 | | 17 | 10000 |
| R175 R174 R173 R172 R171 R170 | | 18 | 10001 |
| R185 R184 R183 R182 R181 R180 | | 19 | 10010 |
| R195 R194 R193 R192 R191 R190 | | 20 | 10011 |
| R205 R204 R203 R202 R201 R200 | | 21 | 10100 |
| R215 R214 R213 R212 R211 R210 | | 22 | 10101 |
| R225 R224 R223 R222 R221 R220 | | 23 | 10110 |
| R235 R234 R233 R232 R231 R230 | | 24 | 10111 |
| R245 R244 R243 R242 R241 R240 | | 25 | 11000 |
| R255 R254 R253 R252 R251 R250 | | 26 | 11001 |
| R265 R264 R263 R262 R261 R260 | | 27 | 11010 |
| R275 R274 R273 R272 R271 R270 | | 28 | 11011 |
| R285 R284 R283 R282 R281 R280 | | 29 | 11100 |
| R295 R294 R293 R292 R291 R290 | | 30 | 11101 |
| R305 R304 R303 R302 R301 R300 | | 31 | 11110 |
| R315 R314 R313 R312 R311 R310 | | 32 | 11111 |

| Color | Look Up Table Output | RGBSET | Look Up Table Input Data |
|-------------------------------|--------------------------------|-----------|--------------------------|
| | Frame Memory Data (6-bits) | Parameter | 65k Color (5-bits) |
| GREEN | G005 G004 G003 G002 G001 G000 | 33 | 000000 |
| | G015 G014 G013 G012 G011 G010 | 34 | 000001 |
| | G025 G024 G023 G022 G021 G020 | 35 | 000010 |
| | G035 G034 G033 G032 G031 G030 | 36 | 000011 |
| | G045 G044 G043 G042 G041 G040 | 37 | 000100 |
| | G055 G054 G053 G052 G051 G050 | 38 | 000101 |
| | G065 G064 G063 G062 G061 G060 | 39 | 000110 |
| | G075 G074 G073 G072 G071 G070 | 40 | 000111 |
| | G085 G084 G083 G082 G081 G080 | 41 | 001000 |
| | G095 G094 G093 G092 G091 G090 | 42 | 001001 |
| | G105 G104 G103 G102 G101 G100 | 43 | 001010 |
| | G115 G114 G113 G112 G111 G110 | 44 | 001011 |
| | G125 G124 G123 G122 G121 G120 | 45 | 001100 |
| | G135 G134 G133 G132 G131 G130 | 46 | 001101 |
| | G145 G144 G143 G142 G141 G140 | 47 | 001110 |
| | G155 G154 G153 G152 G151 G150 | 48 | 001111 |
| | G165 G164 G163 G162 G161 G160 | 49 | 010000 |
| | G175 G174 G173 G172 G171 G170 | 50 | 010001 |
| | G185 G184 G183 G182 G181 G180 | 51 | 010010 |
| | G195 G194 G193 G192 G191 G190 | 52 | 010011 |
| | G205 G204 G203 G202 G201 G200 | 53 | 010100 |
| | G215 G214 G213 G212 G211 G210 | 54 | 010101 |
| | G225 G224 G223 G222 G221 G220 | 55 | 010110 |
| | G235 G234 G233 G232 G231 G230 | 56 | 010111 |
| | G245 G244 G243 G242 G241 G240 | 57 | 011000 |
| | G255 G254 G253 G252 G251 G250 | 58 | 011001 |
| | G265 G264 G263 G262 G261 G260 | 59 | 011010 |
| | G275 G 274 G273 G272 G271 G270 | 60 | 011011 |
| | G285 G 284 G283 G282 G281 G280 | 61 | 011100 |
| | G295 G 294 G293 G292 G291 G290 | 62 | 011101 |
| | G305 G 304 G303 G302 G301 G300 | 63 | 011110 |
| | G315 G 314 G313 G312 G311 G310 | 64 | 011111 |
| G325 G324 G323 G322 G321 G320 | 65 | 100000 | |
| G335 G334 G333 G332 G331 G330 | 66 | 100001 | |
| G345 G344 G343 G342 G341 G340 | 67 | 100010 | |
| G355 G354 G353 G352 G351 G350 | 68 | 100011 | |

| | | |
|-------------------------------|----|--------|
| G365 G364 G363 G362 G361 G360 | 69 | 100100 |
| G375 G374 G373 G372 G371 G370 | 70 | 100101 |
| G385 G384 G383 G382 G381 G380 | 71 | 100110 |
| G395 G394 G393 G392 G391 G390 | 72 | 100111 |
| G405 G404 G403 G402 G401 G400 | 73 | 101000 |
| G415 G414 G413 G412 G411 G410 | 74 | 101001 |
| G425 G424 G423 G422 G421 G420 | 75 | 101010 |
| G435 G434 G433 G432 G431 G430 | 76 | 101011 |
| G445 G444 G443 G442 G441 G440 | 77 | 101100 |
| G455 G454 G453 G452 G451 G450 | 78 | 101101 |
| G465 G464 G463 G462 G461 G460 | 79 | 101110 |
| G475 G474 G473 G472 G471 G470 | 80 | 101111 |
| G485 G484 G483 G482 G481 G480 | 81 | 110000 |
| G495 G494 G493 G492 G491 G490 | 82 | 110001 |
| G505 G504 G503 G502 G501 G500 | 83 | 110010 |
| G515 G514 G513 G512 G511 G510 | 84 | 110011 |
| G525 G524 G523 G522 G521 G520 | 85 | 110100 |
| G535 G534 G533 G532 G531 G530 | 86 | 110101 |
| G545 G544 G543 G542 G541 G540 | 87 | 110110 |
| G555 G554 G553 G552 G551 G550 | 88 | 110111 |
| G565 G564 G563 G562 G561 G560 | 89 | 111000 |
| G575 G574 G573 G572 G571 G570 | 90 | 111001 |
| G585 G584 G583 G582 G581 G580 | 91 | 111010 |
| G595 G594 G593 G592 G591 G590 | 92 | 111011 |
| G605 G604 G603 G602 G601 G600 | 93 | 111100 |
| G615 G614 G613 G612 G611 G610 | 94 | 111101 |
| G625 G624 G623 G622 G621 G620 | 95 | 111110 |
| G635 G634 G633 G632 G631 G630 | 96 | 111111 |

| Color | Look Up Table Output Frame Memory Data (6-bits) | RGBSET Parameter | Look Up Table Input Data 65k Color (5-bits) |
|-------------------------------|--|-------------------------------|--|
| | BLUE | B005 B004 B003 B002 B001 B000 | 97 |
| B015 B014 B013 B012 B011 B010 | | 98 | 00001 |
| B025 B024 B023 B022 B021 B020 | | 99 | 00010 |
| B035 B034 B033 B032 B031 B030 | | 100 | 00011 |
| B045 B044 B043 B042 B041 B040 | | 101 | 00100 |
| B055 B054 B053 B052 B051 B050 | | 102 | 00101 |
| B065 B064 B063 B062 B061 B060 | | 103 | 00110 |

| | | |
|-------------------------------|-----|-------|
| B075 B074 B073 B072 B071 B070 | 104 | 00111 |
| B085 B084 B083 B082 B081 B080 | 105 | 01000 |
| B095 B094 B093 B092 B091 B090 | 106 | 01001 |
| B105 B104 B103 B102 B101 B100 | 107 | 01010 |
| B115 B114 B113 B112 B111 B110 | 108 | 01011 |
| B125 B124 B123 B122 B121 B120 | 109 | 01100 |
| B135 B134 B133 B132 B131 B130 | 110 | 01101 |
| B145 B144 B143 B142 B141 B140 | 111 | 01110 |
| B155 B154 B153 B152 B151 B150 | 112 | 01111 |
| B165 B164 B163 B162 B161 B160 | 113 | 10000 |
| B175 B174 B173 B172 B171 B170 | 114 | 10001 |
| B185 B184 B183 B182 B181 B180 | 115 | 10010 |
| B195 B194 B193 B192 B191 B190 | 116 | 10011 |
| B205 B204 B203 B202 B201 B200 | 117 | 10100 |
| B215 B214 B213 B212 B211 B210 | 118 | 10101 |
| B225 B224 B223 B222 B221 B220 | 119 | 10110 |
| B235 B234 B233 B232 B231 B230 | 120 | 10111 |
| B245 B244 B243 B242 B241 B240 | 121 | 11000 |
| B255 B254 B253 B252 B251 B250 | 122 | 11001 |
| B265 B264 B263 B262 B261 B260 | 123 | 11010 |
| B275 B274 B273 B272 B271 B270 | 124 | 11011 |
| B285 B284 B283 B282 B281 B280 | 125 | 11100 |
| B295 B294 B293 B292 B291 B290 | 126 | 11101 |
| B305 B304 B303 B302 B301 B300 | 127 | 11110 |
| B315 B314 B313 B312 B311 B310 | 128 | 11111 |

9.18.2 4096 Color to 262,144 Color

| Color | Look Up Table Output | RGBSET | Look Up Table Input Data |
|-------|-------------------------------|-----------|--------------------------|
| | Frame Memory Data (6-bits) | Parameter | 4k Color (4-bits) |
| RED | R005 R004 R003 R002 R001 R000 | 1 | 0000 |
| | R015 R014 R013 R012 R011 R010 | 2 | 0001 |
| | R025 R024 R023 R022 R021 R020 | 3 | 0010 |
| | R035 R034 R033 R032 R031 R030 | 4 | 0011 |
| | R045 R044 R043 R042 R041 R040 | 5 | 0100 |
| | R055 R054 R053 R052 R051 R050 | 6 | 0101 |
| | R065 R064 R063 R062 R061 R060 | 7 | 0110 |
| | R075 R074 R073 R072 R071 R070 | 8 | 0111 |
| | R085 R084 R083 R082 R081 R080 | 9 | 1000 |
| | R095 R094 R093 R092 R091 R090 | 10 | 1001 |
| | R105 R104 R103 R102 R101 R100 | 11 | 1010 |
| | R115 R114 R113 R112 R111 R110 | 12 | 1011 |
| | R125 R124 R123 R122 R121 R120 | 13 | 1100 |
| | R135 R134 R133 R132 R131 R130 | 14 | 1101 |
| | R145 R144 R143 R142 R141 R140 | 15 | 1110 |
| | R155 R154 R153 R152 R151 R150 | 16 | 1111 |
| | R165 R164 R163 R162 R161 R160 | 17 | Not used |
| | | | |
| | R315 R314 R313 R312 R311 R310 | 32 | |
| GREEN | G005 G004 G003 G002 G001 G000 | 33 | 0000 |
| | G015 G014 G013 G012 G011 G010 | 34 | 0001 |
| | G025 G024 G023 G022 G021 G020 | 35 | 0010 |
| | G035 G034 G033 G032 G031 G030 | 36 | 0011 |
| | G045 G044 G043 G042 G041 G040 | 37 | 0100 |
| | G055 G054 G053 G052 G051 G050 | 38 | 0101 |
| | G065 G064 G063 G062 G061 G060 | 39 | 0110 |
| | G075 G074 G073 G072 G071 G070 | 40 | 0111 |
| | G085 G084 G083 G082 G081 G080 | 41 | 1000 |
| | G095 G094 G093 G092 G091 G090 | 42 | 1001 |
| | G105 G104 G103 G102 G101 G100 | 43 | 1010 |
| | G115 G114 G113 G112 G111 G110 | 44 | 1011 |
| | G125 G124 G123 G122 G121 G120 | 45 | 1100 |
| | G135 G134 G133 G132 G131 G130 | 46 | 1101 |
| | G145 G144 G143 G142 G141 G140 | 47 | 1110 |
| | G155 G154 G153 G152 G151 G150 | 48 | 1111 |

| | | | |
|-------------------------------|-------------------------------|-----|----------|
| | G165 G164 G163 G162 G161 G160 | 49 | Not used |
| | | | |
| | G635 G634 G633 G632 G631 G630 | 96 | |
| BLUE | B005 B004 B003 B002 B001 B000 | 97 | 0000 |
| | B015 B014 B013 B012 B011 B010 | 98 | 0001 |
| | B025 B024 B023 B022 B021 B020 | 99 | 0010 |
| | B035 B034 B033 B032 B031 B030 | 100 | 0011 |
| | B045 B044 B043 B042 B041 B040 | 101 | 0100 |
| | B055 B054 B053 B052 B051 B050 | 102 | 0101 |
| | B065 B064 B063 B062 B061 B060 | 103 | 0110 |
| | B075 B074 B073 B072 B071 B070 | 104 | 0111 |
| | B085 B084 B083 B082 B081 B080 | 105 | 1000 |
| | B095 B094 B093 B092 B091 B090 | 106 | 1001 |
| | B105 B104 B103 B102 B101 B100 | 107 | 1010 |
| | B115 B114 B113 B112 B111 B110 | 108 | 1011 |
| | B125 B124 B123 B122 B121 B120 | 109 | 1100 |
| | B135 B134 B133 B132 B131 B130 | 110 | 1101 |
| | B145 B144 B143 B142 B141 B140 | 111 | 1110 |
| | B155 B154 B153 B152 B151 B150 | 112 | 1111 |
| | B165 B164 B163 B162 B161 B160 | 113 | Not used |
| | | | |
| B315 B314 B313 B312 B311 B310 | 128 | | |

9.19 Sleep Out-Command and Self-Diagnostic Functions of the Display Module

9.19.1 Register Loading Detection

Sleep Out-command (See section 0 “Sleep Out (11h)”) is a trigger for an internal function of the display module, which indicates, if the display module loading function of factory default values from MTP (or similar device) to registers of the display controller is working properly.

There are compared factory values of the MTP and register values of the display controller by the display controller. If those both values (MTP and register values) are same, there is inverted (=increased by 1) a bit, which is defined in command 0 “Read Display Self-Diagnostic Result (0Fh)” (=RDDSDR) (The used bit of this command is D7). If those both values are not same, this bit (D7) is not inverted (= increased by 1).

The flow chart for this internal function is following:

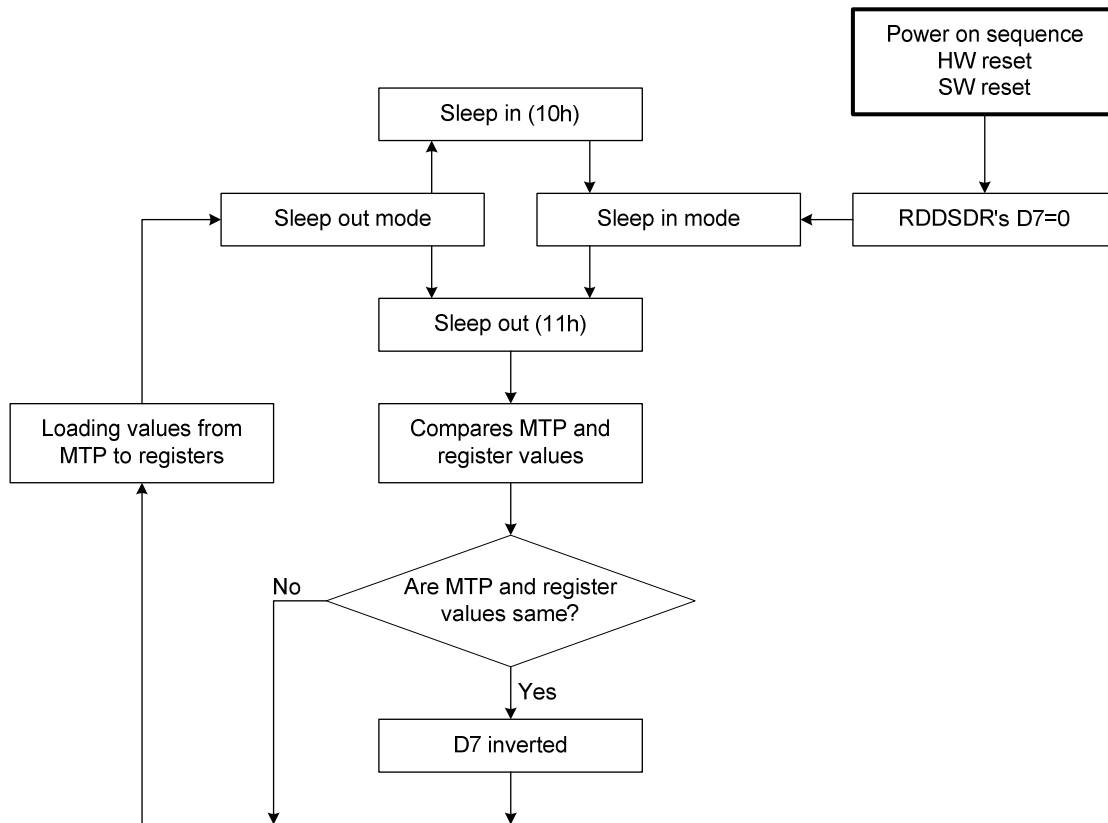

Note: There is not compared and loaded register values, which can be changed by user (00h to AFh and DAh to DDh), by the display module.

9.19.2 Functionality Detection

Sleep Out-command (See section 0 “Sleep Out (11h)”) is a trigger for an internal function of the display module, which indicates, if the display module is still running and meets functionality requirements.

The internal function (= the display controller) is comparing, if the display module is still meeting functionality requirements (only Booster voltage level). If functionality requirement is met, there is inverted (= increased by 1) a bit, which defined in command 0 “Read Display Self- Diagnostic Result (0Fh)” (= RDDSDR) (The used bit of this command is D6). If functionality requirement is not same, this bit (D6) is not inverted (= increased by 1).The flow chart for this internal function is following:

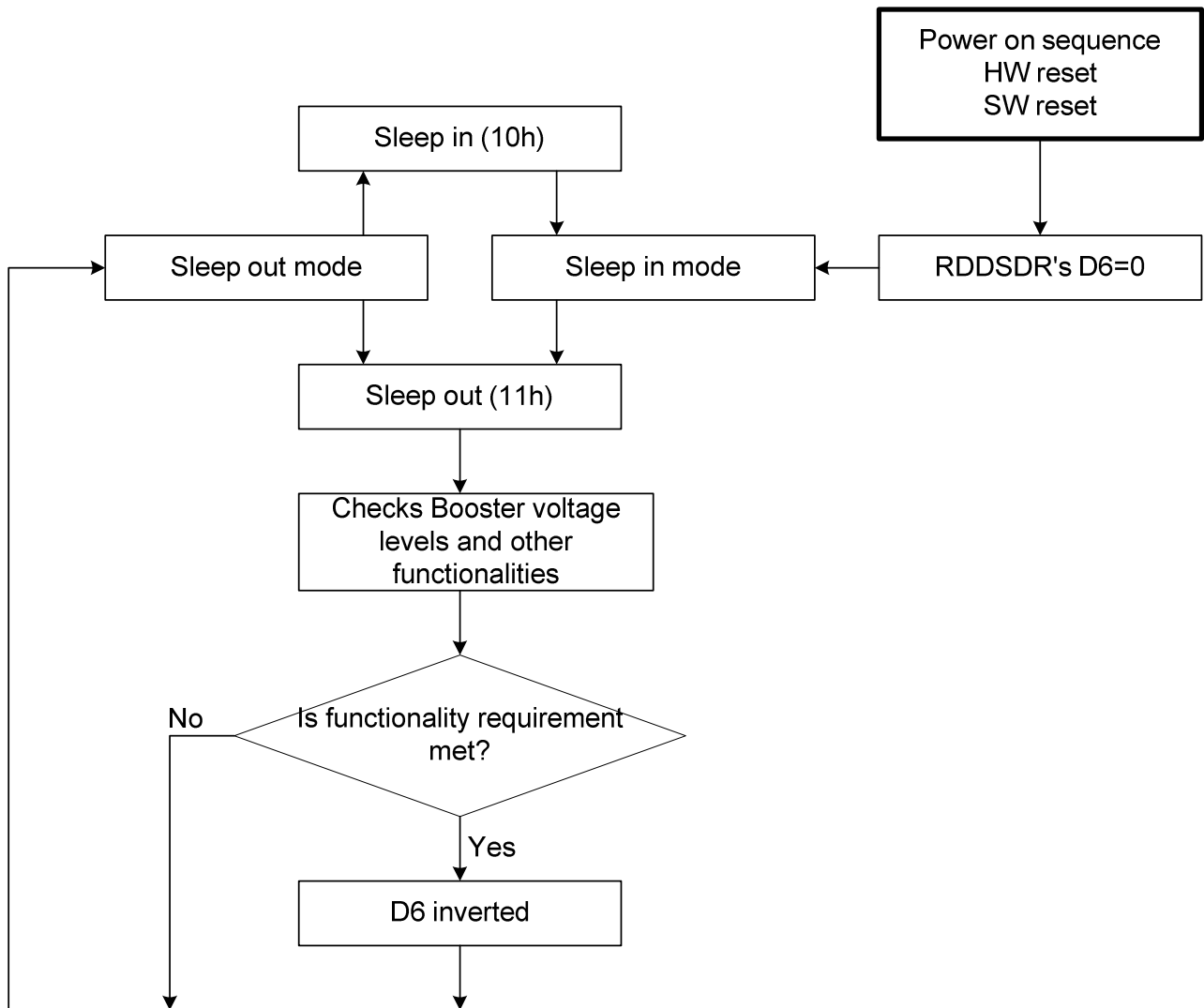

Note: There is needed 120msec after Sleep Out -command, when there is changing from Sleep In -mode to Sleep Out -mode, before there is possible to check if functionality requirements are met and a value of RDDSDR's D6 is valid. Otherwise, there is 5msec delay for D6's value, when Sleep Out -command is sent in Sleep Out -mode.

9.19.3 Chip Attachment Detection (Optional)

Sleep Out-command (See section 0 “Sleep Out (11h)”) is a trigger for an internal function of the display module, which indicates, if a chip or chips (e.g. driver, etc.) of the display module is/are attached to the circuit route of a flex foil or display glass ITO.

There is inverted (= increased by 1) a bit, which is defined in command 0 “Read Display Self- Diagnostic Result (0Fh)” (= RDDSDR) (The used bit of this command is D5), if the chip or chips is/are attached to the circuit route of the flex or display glass. If this chip is or those chips are not attached to the circuit route of the flex or display glass, this bit (D5) is not inverted (= increased by 1).

The following figure is for reference purposes; how this chip attachment can be implemented e.g. there are connected together 2 bumps via route of ITO or the flex foil on 4 corners of the driver (chip).

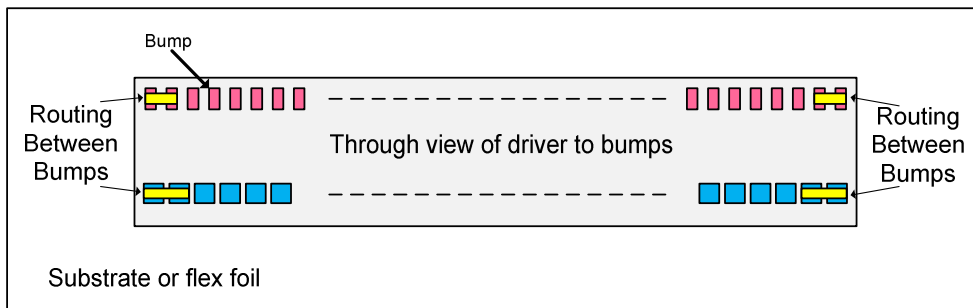

The flow chart for this internal function is following:

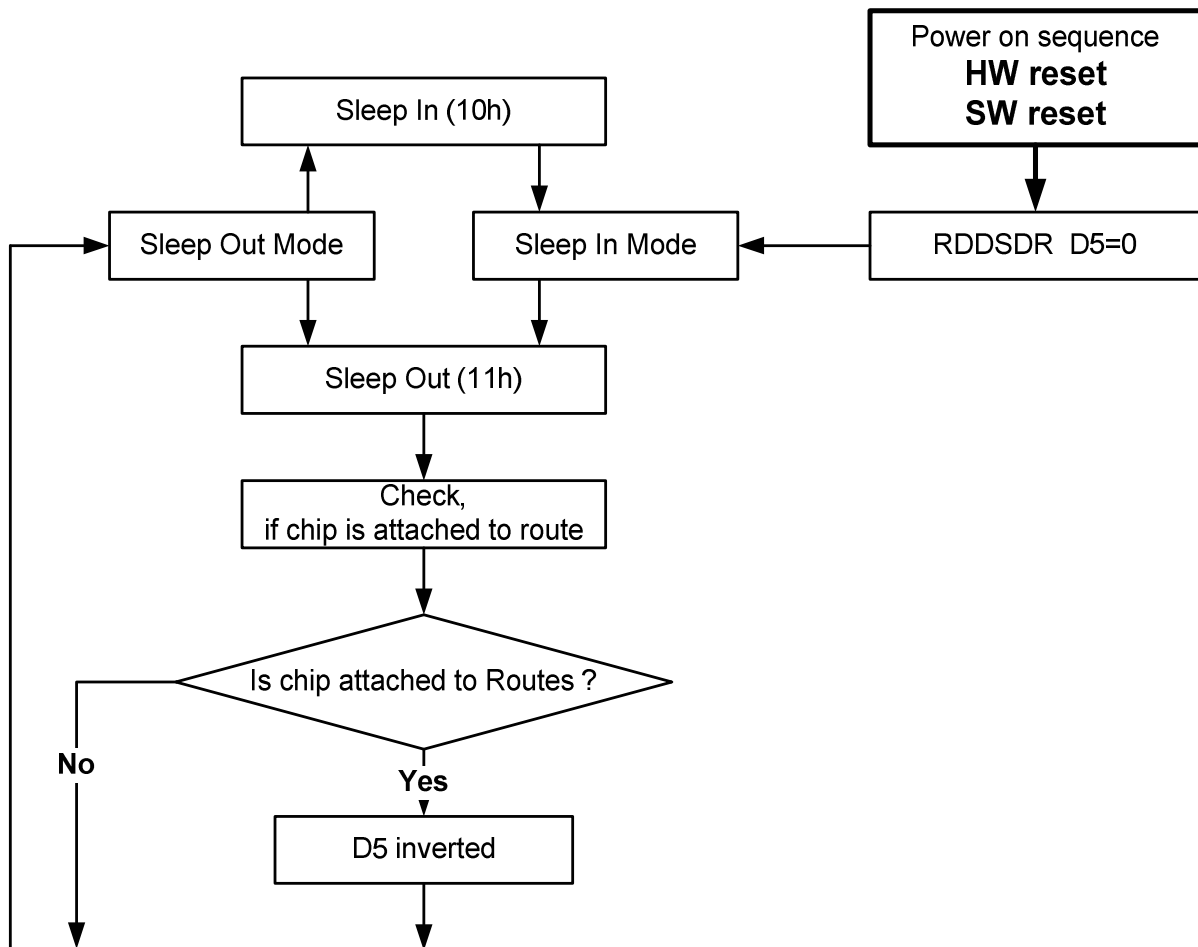

9.19.4 Display Glass Break Detection (Optional)

Sleep Out-command (See section 0 “Sleep Out (11h)”) is a trigger for an internal function of the display module, which indicates, if the display glass of the display module is broken or not.

There is inverted (= increased by 1) a bit, which is defined in command 0 “Read Display Self-Diagnostic Result (0Fh)” (= RDDSDR) (The used bit of this command is D4), if the display glass is not broken. If this display glass is broken, this bit (D4) is not inverted (= increased by 1).

The following figure is a reference, how this glass break detection can be implemented e.g. there is connected together 2 bumps via route of ITO. This route of ITO is the nearest route of the edge of the display glass.

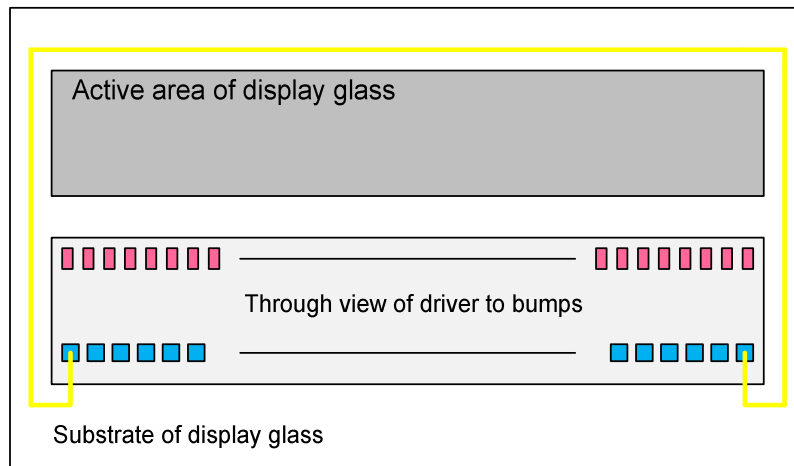

The flow chart for this internal function is following:

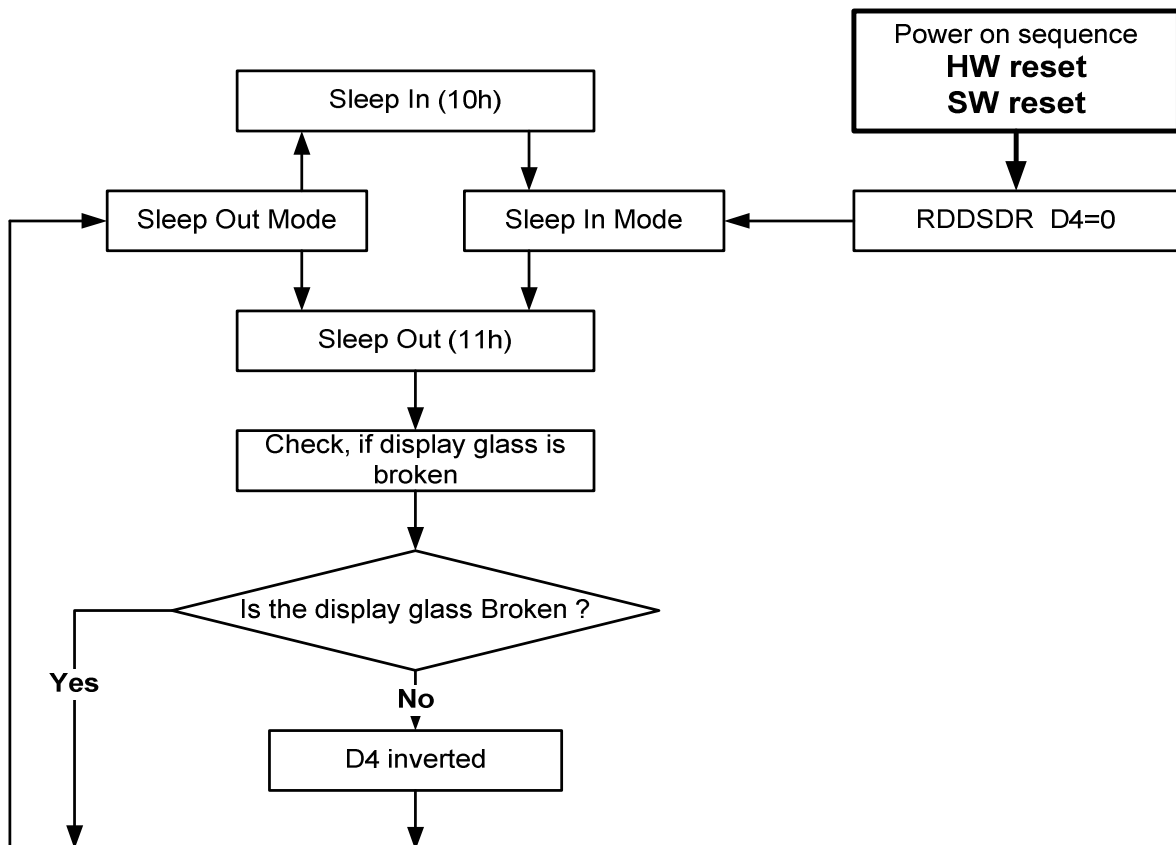

10 COMMAND

10.1 System Function Command List and Description

Table 15 System Function Command List (1)

| Instruction | Refer | D/CX | WRX | RDX | D17-8 | D7 | D6 | D5 | D4 | D3 | D2 | D1 | D0 | Hex | Function |
|---------------|-------|------|-----|-----|-------|-------|-------|-------|--------|-------|-------|-------|-------|-------|-------------------------------------|
| NOP | 0 | 0 | ↑ | 1 | - | 0 | 0 | 0 | 0 | 0 | 0 | 0 | 0 | (00h) | No Operation |
| SWRESET | 0 | 0 | ↑ | 1 | - | 0 | 0 | 0 | 0 | 0 | 0 | 0 | 1 | (01h) | Software Reset |
| RDDID | 0 | 0 | ↑ | 1 | - | 0 | 0 | 0 | 0 | 0 | 1 | 0 | 0 | (04h) | Read Display ID |
| | | 1 | 1 | ↑ | - | - | - | - | - | - | - | - | - | - | Dummy Read |
| | | 1 | 1 | ↑ | - | ID17 | ID16 | ID15 | ID14 | ID13 | ID12 | ID11 | ID10 | - | ID1 Read |
| | | 1 | 1 | ↑ | - | 1 | ID26 | ID25 | ID24 | ID23 | ID22 | ID21 | ID20 | - | ID2 Read |
| | | 1 | 1 | ↑ | - | ID37 | ID36 | ID35 | ID34 | ID33 | ID32 | ID31 | ID30 | - | ID3 Read |
| RDDST | 0 | 0 | ↑ | 1 | - | 0 | 0 | 0 | 0 | 1 | 0 | 0 | 1 | (09h) | Read Display Status |
| | | 1 | 1 | ↑ | - | - | - | - | - | - | - | - | - | - | Dummy Read |
| | | 1 | 1 | ↑ | - | BSTON | MY | MX | MV | ML | RGB | MH | ST24 | - | - |
| | | 1 | 1 | ↑ | - | ST23 | IFPF2 | IFPF1 | IFPF0 | IDMON | PTLON | SLOUT | NORON | - | - |
| | | 1 | 1 | ↑ | - | VSSON | ST14 | INVON | ST12 | ST11 | DISON | TEON | GCS2 | - | - |
| RDDPM | 0 | 0 | ↑ | 1 | - | 0 | 0 | 0 | 0 | 1 | 0 | 1 | 0 | (0Ah) | Read Display Power Mode |
| | | 1 | 1 | ↑ | - | - | - | - | - | - | - | - | - | - | Dummy Read |
| | | 1 | 1 | ↑ | - | BSTON | IDMON | PTLON | SLPOUT | NORON | DISON | - | - | - | - |
| RDD MADCTL | 0 | 0 | ↑ | 1 | - | 0 | 0 | 0 | 0 | 1 | 0 | 1 | 1 | (0Bh) | Read Display MADCTL |
| | | 1 | 1 | ↑ | - | - | - | - | - | - | - | - | - | - | Dummy Read |
| | | 1 | 1 | ↑ | - | MY | MX | MV | ML | RGB | MH | - | - | - | - |
| RDD COLMOD | 0 | 0 | ↑ | 1 | - | 0 | 0 | 0 | 0 | 1 | 1 | 0 | 0 | (0Ch) | Read Display Pixel Format |
| | | 1 | 1 | ↑ | - | - | - | - | - | - | - | - | - | - | Dummy Read |
| | | 1 | 1 | ↑ | - | 0 | 0 | 0 | 0 | - | IFPF2 | IFPF1 | IFPF0 | - | - |
| RDDIM | 0 | 0 | ↑ | 1 | - | 0 | 0 | 0 | 0 | 1 | 1 | 0 | 1 | (0Dh) | Read Display Image Mode |
| | | 1 | 1 | ↑ | - | - | - | - | - | - | - | - | - | - | Dummy Read |
| | | 1 | 1 | ↑ | - | VSSON | D6 | INVON | - | - | GCS2 | GCS1 | GCS0 | - | - |
| RDDSM | 0 | 0 | ↑ | 1 | - | 0 | 0 | 0 | 0 | 1 | 1 | 1 | 0 | (0Eh) | Read Display Signal Mode |
| | | 1 | 1 | ↑ | - | - | - | - | - | - | - | - | - | - | Dummy Read |
| | | 1 | 1 | ↑ | - | TEON | TEM | - | - | - | - | - | - | - | - |
| RDDSDR | 0 | 0 | ↑ | 1 | - | 0 | 0 | 0 | 0 | 1 | 1 | 1 | 1 | (0Fh) | Read Display Self-diagnostic result |
| | | 1 | 1 | ↑ | - | - | - | - | - | - | - | - | - | - | Dummy Read |
| | | 1 | 1 | ↑ | - | RELD | FUND | ATTD | BRD | - | - | - | - | - | - |

"-": Don't care

Table 16 System Function Command List (2)

| Instruction | Refer | D/CX | WRX | RDX | D17-8 | D7 | D6 | D5 | D4 | D3 | D2 | D1 | D0 | Hex | Function |
|-------------|-------|------|-----|-----|-------|------|------|------|------|------|------|------|------|-------|-------------------------------------|
| SLPIN | 0 | 0 | ↑ | 1 | - | 0 | 0 | 0 | 1 | 0 | 0 | 0 | 0 | (10h) | Sleep In & Booster Off |
| SLPOUT | 0 | 0 | ↑ | 1 | - | 0 | 0 | 0 | 1 | 0 | 0 | 0 | 1 | (11h) | Sleep Out & Booster On |
| PTLON | 0 | 0 | ↑ | 1 | - | 0 | 0 | 0 | 1 | 0 | 0 | 1 | 0 | (12h) | Partial Mode On |
| NORON | 0 | 0 | ↑ | 1 | - | 0 | 0 | 0 | 1 | 0 | 0 | 1 | 1 | (13h) | Partial Off (Normal) |
| INVOFF | 0 | 0 | ↑ | 1 | - | 0 | 0 | 1 | 0 | 0 | 0 | 0 | 0 | (20h) | Display Inversion Off (Normal) |
| INVON | 0 | 0 | ↑ | 1 | - | 0 | 0 | 1 | 0 | 0 | 0 | 0 | 1 | (21h) | Display Inversion On |
| GAMSET | 0 | 0 | ↑ | 1 | - | 0 | 0 | 1 | 0 | 0 | 1 | 1 | 0 | (26h) | Gamma Curve Select |
| | | 1 | ↑ | 1 | - | - | - | - | - | GC3 | GC2 | GC1 | GC0 | | - |
| DISPOFF | 0 | 0 | ↑ | 1 | - | 0 | 0 | 1 | 0 | 1 | 0 | 0 | 0 | (28h) | Display Off |
| DISPON | 0 | 0 | ↑ | 1 | - | 0 | 0 | 1 | 0 | 1 | 0 | 0 | 1 | (29h) | Display On |
| CASET | 0 | 0 | ↑ | 1 | - | 0 | 0 | 1 | 0 | 1 | 0 | 1 | 0 | (2Ah) | Column Address Set |
| | | 1 | ↑ | 1 | - | XS15 | XS14 | XS13 | XS12 | XS11 | XS10 | XS9 | XS8 | | X Address Start: $0 \leq XS \leq X$ |
| | | 1 | ↑ | 1 | - | XS7 | XS6 | XS5 | XS4 | XS3 | XS2 | XS1 | XS0 | | |
| | | 1 | ↑ | 1 | - | XE15 | XE14 | XE13 | XE12 | XE11 | XE10 | XE9 | XE8 | | X Address End: $S \leq XE \leq X$ |
| RASET | 0 | 0 | ↑ | 1 | - | 0 | 0 | 1 | 0 | 1 | 0 | 1 | 1 | (2Bh) | Row Address Set |
| | | 1 | ↑ | 1 | - | YS15 | YS14 | YS13 | YS12 | YS11 | YS10 | YS9 | YS8 | | Y Address Start: $0 \leq YS \leq Y$ |
| | | 1 | ↑ | 1 | - | YS7 | YS6 | YS5 | YS4 | YS3 | YS2 | YS1 | YS0 | | |
| | | 1 | ↑ | 1 | - | YE15 | YE14 | YE13 | YE12 | YE11 | YE10 | YE9 | YE8 | | Y Address End: $S \leq YE \leq Y$ |
| RAMWR | 0 | 0 | ↑ | 1 | - | 0 | 0 | 1 | 0 | 1 | 1 | 0 | 0 | (2Ch) | Memory Write |
| | | 1 | ↑ | 1 | - | D7 | D6 | D5 | D4 | D3 | D2 | D1 | D0 | | Write Data |
| RGBSET | 0 | 0 | ↑ | 1 | - | 0 | 0 | 1 | 0 | 1 | 1 | 0 | 1 | (2Dh) | LUT for 4k,65k,262k Color display |
| | | 1 | ↑ | 1 | - | - | - | R005 | R004 | R003 | R002 | R001 | R000 | | Red Tone 0 |
| | | 1 | ↑ | 1 | - | - | - | : | : | : | : | : | : | | : |
| | | 1 | ↑ | 1 | - | - | - | Ra5 | Ra4 | Ra3 | Ra2 | Ra1 | Ra0 | | Red Tone "a" |
| | | 1 | ↑ | 1 | - | - | - | G005 | G004 | G003 | G002 | G001 | G000 | | Green Tone 0 |
| | | 1 | ↑ | 1 | - | - | - | : | : | : | : | : | : | | : |
| | | 1 | ↑ | 1 | - | - | - | Gb5 | Gb4 | Gb3 | Gb2 | Gb1 | Gb0 | | Green Tone "b" |
| | | 1 | ↑ | 1 | - | - | - | B005 | B004 | B003 | B002 | B001 | B000 | | Blue Tone 0 |
| RAMRD | 0 | 0 | ↑ | 1 | - | 0 | 0 | 1 | 0 | 1 | 1 | 1 | 0 | (2Eh) | Memory Read |
| | | 1 | 1 | ↑ | - | - | - | - | - | - | - | - | - | | Dummy Read |
| | | 1 | 1 | ↑ | - | D7 | D6 | D5 | D4 | D3 | D2 | D1 | D0 | | Read Data |

"-": Don't care

Table 17 System Function command List (3)

| Instruction | Refer | D/CX | WRX | RDX | D17-8 | D7 | D6 | D5 | D4 | D3 | D2 | D1 | D0 | Hex | Function |
|-------------|---------|------|-----|-----|-------|-------|-------|-------|-------|-------|-------|-------|-------|-------|---|
| PTLAR | 10.1.25 | 0 | ↑ | 1 | - | 0 | 0 | 1 | 1 | 0 | 0 | 0 | 0 | (30h) | Partial Start/End Address Set |
| | | 1 | ↑ | 1 | - | PSL15 | PSL14 | PSL13 | PSL12 | PSL11 | PSL10 | PSL9 | PSL8 | | Partial Start Address (0,1,2, ..P) |
| | | 1 | ↑ | 1 | - | PSL7 | PSL6 | PSL5 | PSL4 | PSL3 | PSL2 | PSL1 | PSL0 | | |
| | | 1 | ↑ | 1 | - | PEL15 | PEL14 | PEL13 | PEL12 | PEL11 | PEL10 | PEL9 | PEL8 | | Partial End Address (0,1,2, ..., P) |
| SCRLAR | 10.1.26 | 0 | ↑ | 1 | - | 0 | 0 | 1 | 1 | 0 | 0 | 1 | 1 | (33h) | Scroll area set |
| | | 1 | ↑ | 1 | - | - | - | - | - | - | - | - | - | | Top fixed area (0,1, 2, ..., 161) |
| | | 1 | ↑ | 1 | - | TFA7 | TFA6 | TFA5 | TFA4 | TFA3 | TFA2 | TFA1 | TFA0 | | |
| | | 1 | ↑ | 1 | - | - | - | - | - | - | - | - | - | | Vertical scroll area (0,1, 2, ..., 161) |
| | | 1 | ↑ | 1 | - | VSA7 | VSA6 | VSA5 | VSA4 | VSA3 | VSA2 | VSA1 | VSA0 | | |
| | | 1 | ↑ | 1 | - | BFA7 | BFA6 | BFA5 | BFA4 | BFA3 | BFA2 | BFA1 | BFA0 | | Bottom fixed area (0,1, 2, ..., 161) |
| TEOFF | 10.1.27 | 0 | ↑ | 1 | - | 0 | 0 | 1 | 1 | 0 | 1 | 0 | 0 | (34h) | Tearing effect line off |
| TEON | 10.1.28 | 0 | ↑ | 1 | - | 0 | 0 | 1 | 1 | 0 | 1 | 0 | 1 | (35h) | Tearing Effect Mode Set & on |
| | | 1 | ↑ | 1 | - | - | - | - | - | - | - | - | TEM | | Mode1: TEM="0" Mode2: TEM="1" |
| MADCTL | 10.1.29 | 0 | ↑ | 1 | - | 0 | 0 | 1 | 1 | 0 | 1 | 1 | 0 | (36h) | Memory Data Access Control |
| | | 1 | ↑ | 1 | - | MY | MX | MV | ML | RGB | MH | - | - | | - |
| VSCSAD | 10.1.30 | 0 | ↑ | 1 | - | 0 | 0 | 1 | 1 | 0 | 1 | 1 | 1 | (37h) | Scroll Start Address of RAM |
| | | 1 | 1 | 1 | - | - | - | - | - | - | - | - | - | | SSA=0,1,2,....,161 |
| | | 1 | 1 | 1 | - | SSA7 | SSA6 | SSA5 | SSA4 | SSA3 | SSA2 | SSA1 | SSA0 | | |
| IDMOFF | 10.1.31 | 0 | ↑ | 1 | - | 0 | 0 | 1 | 1 | 1 | 0 | 0 | 0 | (38h) | Idle Mode Off |
| IDMON | 10.1.32 | 0 | ↑ | 1 | - | 0 | 0 | 1 | 1 | 1 | 0 | 0 | 1 | (39h) | Idle Mode On |
| COLMOD | 10.1.33 | 0 | ↑ | 1 | - | 0 | 0 | 1 | 1 | 1 | 0 | 1 | 0 | (3Ah) | Interface Pixel Format |
| | | 1 | ↑ | 1 | - | - | - | - | - | - | - | IFPF2 | IFPF1 | IFPF0 | |
| RDID1 | 10.1.34 | 0 | ↑ | 1 | - | 1 | 1 | 0 | 1 | 1 | 0 | 1 | 0 | (DAh) | Read ID1 |
| | | 1 | 1 | ↑ | - | - | - | - | - | - | - | - | - | | Dummy Read |
| | | 1 | 1 | ↑ | - | ID17 | ID16 | ID15 | ID14 | ID13 | ID12 | ID11 | ID10 | | Read Parameter |
| RDID2 | 10.1.35 | 0 | ↑ | 1 | - | 1 | 1 | 0 | 1 | 1 | 0 | 1 | 1 | (DBh) | Read ID2 |
| | | 1 | 1 | ↑ | - | - | - | - | - | - | - | - | - | | Dummy Read |
| | | 1 | 1 | ↑ | - | 1 | ID26 | ID25 | ID24 | ID23 | ID22 | ID21 | ID20 | | Read Parameter |
| RDID3 | 10.1.36 | 0 | ↑ | 1 | - | 1 | 1 | 0 | 1 | 1 | 1 | 0 | 0 | (DCh) | Read ID3 |
| | | 1 | 1 | ↑ | - | - | - | - | - | - | - | - | - | | Dummy Read |
| | | 1 | 1 | ↑ | - | ID37 | ID36 | ID35 | ID34 | ID33 | ID32 | ID31 | ID30 | | Read Parameter |

"-": Don't care

Note 1: After the H/W reset by RESX pin or S/W reset by SWRESET command, each internal register becomes default state (Refer "RESET TABLE" section)

Note 2: Undefined commands are treated as NOP (00 h) command.

Note 3: B0 to D9 and DA to F are for factory use of driver supplier.

Note 4: Commands 10h, 12h, 13h, 20h, 21h, 26h, 28h, 29h, 30h, 33h, 36h (ML parameter only), 37h, 38h and 39h are updated during V-sync when Module is in Sleep Out Mode to avoid abnormal visual effects. During Sleep In mode, these commands are updated immediately. Read status (09h), Read Display Power Mode (0Ah), Read Display MADCTL (0Bh), Read Display Pixel Format (0Ch), Read Display Image Mode (0Dh), Read Display Signal Mode (0Eh).

10.1.1 NOP (00h)

| 00H | | NOP (No Operation) | | | | | | | | | | | |
|-------------|--------------------------------|--------------------|-----|-------|----|----|----|----|----|----|----|----|-------|
| Inst / Para | D/CX | WRX | RDX | D17-8 | D7 | D6 | D5 | D4 | D3 | D2 | D1 | D0 | HEX |
| NOP | 0 | ↑ | 1 | - | 0 | 0 | 0 | 0 | 0 | 0 | 0 | 0 | (00h) |
| Parameter | No Parameter | | | | | | | | | | | | - |
| Description | This command is empty command. | | | | | | | | | | | | |

“-“ Don't care

10.1.2 SWRESET (01h): Software Reset

| 01H | SWRESET (Software Reset) | | | | | | | | | | | | |
|-------------|--|-----|-----|-------|----|----|----|----|----|----|----|----|-------|
| Inst / Para | D/CX | WRX | RDX | D17-8 | D7 | D6 | D5 | D4 | D3 | D2 | D1 | D0 | HEX |
| SWRESET | 0 | ↑ | 1 | - | 0 | 0 | 0 | 0 | 0 | 0 | 0 | 1 | (01h) |
| Parameter | No Parameter | | | | | | | | | | | | |
| Description | “-“ Don't care -If Software Reset is applied during Sleep In mode, it will be necessary to wait 120msec before sending next command. -The display module loads all default values to the registers during 120msec. -If Software Reset is applied during Sleep Out or Display On Mode, it will be necessary to wait 120msec before sending next command. | | | | | | | | | | | | |
| Flow Chart | <pre> graph TD A[SWRESET] --> B[Display whole blank screen] B --> C[Set Commands to S/W Default Value] C --> D[Sleep In Mode] </pre> | | | | | | | | | | | | |

10.1.3 RDDID (04h): Read Display ID

| 04H | RDDID (Read Display ID) | | | | | | | | | | | | | | | | | | | | | | | | | | | | | | | |
|---------------------------|--|----------|----------|-------|--------|---------------|------|------|------|------|------|-------------------|-------|----------|----------|----------|------|----------|----------|-----------|------|----------|----------|--|--|--|--|--|--|--|--|--|
| Inst / Para | D/CX | WRX | RDX | D17-8 | D7 | D6 | D5 | D4 | D3 | D2 | D1 | D0 | HEX | | | | | | | | | | | | | | | | | | | |
| RDDID | 0 | ↑ | 1 | - | 0 | 0 | 0 | 0 | 0 | 1 | 0 | 0 | (04h) | | | | | | | | | | | | | | | | | | | |
| 1 st Parameter | 1 | 1 | ↑ | - | - | - | - | - | - | - | - | - | - | | | | | | | | | | | | | | | | | | | |
| 2 nd Parameter | 1 | 1 | ↑ | - | ID17 | ID16 | ID15 | ID14 | ID13 | ID12 | ID11 | ID10 | | | | | | | | | | | | | | | | | | | | |
| 3 rd Parameter | 1 | 1 | ↑ | - | 1 | ID26 | ID25 | ID24 | ID23 | ID22 | ID21 | ID20 | | | | | | | | | | | | | | | | | | | | |
| 4 th Parameter | 1 | 1 | ↑ | - | ID37 | ID36 | ID35 | ID34 | ID33 | ID32 | ID31 | ID30 | | | | | | | | | | | | | | | | | | | | |
| Description | -This read byte returns 24-bit display identification information. -The 1st parameter is dummy data -The 2nd parameter (ID17 to ID10): LCD module's manufacturer ID. -The 3rd parameter (ID26 to ID20): LCD module/driver version ID -The 4th parameter (ID37 to UD30): LCD module/driver ID. -Commands RDID1/2/3(DAh, DBh, DCh) read data correspond to the parameters 2,3,4 of the command 04h, respectively. "- Don't care | | | | | | | | | | | | | | | | | | | | | | | | | | | | | | | |
| Default | <table border="1"> <thead> <tr> <th rowspan="2">Status</th> <th colspan="3">Default Value</th> </tr> <tr> <th>ID1</th> <th>ID2</th> <th>ID3</th> </tr> </thead> <tbody> <tr> <td>Power On Sequence</td> <td>0x7C</td> <td>NV Value</td> <td>NV Value</td> </tr> <tr> <td>SW Reset</td> <td>0x7C</td> <td>NV Value</td> <td>NV Value</td> </tr> <tr> <td>H/W Reset</td> <td>0x7C</td> <td>NV Value</td> <td>NV Value</td> </tr> </tbody> </table> | | | | Status | Default Value | | | ID1 | ID2 | ID3 | Power On Sequence | 0x7C | NV Value | NV Value | SW Reset | 0x7C | NV Value | NV Value | H/W Reset | 0x7C | NV Value | NV Value | | | | | | | | | |
| Status | Default Value | | | | | | | | | | | | | | | | | | | | | | | | | | | | | | | |
| | ID1 | ID2 | ID3 | | | | | | | | | | | | | | | | | | | | | | | | | | | | | |
| Power On Sequence | 0x7C | NV Value | NV Value | | | | | | | | | | | | | | | | | | | | | | | | | | | | | |
| SW Reset | 0x7C | NV Value | NV Value | | | | | | | | | | | | | | | | | | | | | | | | | | | | | |
| H/W Reset | 0x7C | NV Value | NV Value | | | | | | | | | | | | | | | | | | | | | | | | | | | | | |
| Flow Chart | <div style="display: flex; justify-content: space-around;"> <div style="text-align: center;"> <p>Serial I/F Mode</p> </div> <div style="text-align: center;"> <p>Parallel I/F Mode</p> </div> </div> <div style="margin-top: 20px;"> <p>Legend</p> <ul style="list-style-type: none"> Command Parameter Display Action Mode Sequential transfer </div> | | | | | | | | | | | | | | | | | | | | | | | | | | | | | | | |

10.1.4 RDDST (09h): Read Display Status

| 09H | RDDST (Read Display Status) | | | | | | | | | | | | |
|---------------------------|---|----------------------------|-----|--|-------|-------|-------|-------|-------|-------|-------|-------|-------|
| Inst / Para | D/CX | WRX | RDX | D17-8 | D7 | D6 | D5 | D4 | D3 | D2 | D1 | D0 | HEX |
| RDDST | 0 | ↑ | 1 | - | 0 | 0 | 0 | 0 | 1 | 0 | 0 | 1 | (09h) |
| 1 st Parameter | 1 | 1 | ↑ | - | - | - | - | - | - | - | - | - | - |
| 2 nd Parameter | 1 | 1 | ↑ | - | BSTON | MY | MX | MV | ML | RGB | MH | ST24 | |
| 3 rd Parameter | 1 | 1 | ↑ | - | ST23 | IFPF2 | IFPF1 | IFPF0 | IDMON | PTLON | SLOUT | NORON | |
| 4 th Parameter | 1 | 1 | ↑ | - | ST15 | ST14 | INVON | ST12 | ST11 | DISON | TEON | GCS2 | |
| 5 th Parameter | 1 | 1 | ↑ | - | GCS1 | GCS0 | TEM | ST4 | ST3 | ST2 | ST1 | ST0 | |
| Description | This command indicates the current status of the display as described in the table below: | | | | | | | | | | | | |
| | Bit | Description | | Value | | | | | | | | | |
| | BSTON | Booster Voltage Status | | '1' =Booster on, '0' =Booster off | | | | | | | | | |
| | MY | Row Address Order (MY) | | '1' =Decrement, (Bottom to Top, when MADCTL (36h) D7='1') '0' =Increment, (Top to Bottom, when MADCTL (36h) D7='0') | | | | | | | | | |
| | MX | Column Address Order (MX) | | '1' =Decrement, (Right to Left, when MADCTL (36h) D6='1') '0' =Increment, (Left to Right, when MADCTL (36h) D6='1') | | | | | | | | | |
| | MV | Row/Column Exchange (MV) | | '1' = Row/column exchange, (when MADCTL (36h) D5='1') '0' = Normal, (when MADCTL (36h) D5='0') | | | | | | | | | |
| | ML | Scan Address Order (ML) | | '0' =Decrement, (LCD refresh Top to Bottom, when MADCTL (36h) D4='0') '1' =Increment, (LCD refresh Bottom to Top, when MADCTL (36h) D4='1') | | | | | | | | | |
| | RGB | RGB/ BGR Order (RGB) | | '1' =BGR, (When MADCTL (36h) D3='1') '0' =RGB, (When MADCTL (36h) D3='0') | | | | | | | | | |
| | MH | Horizontal Order | | '0' =Decrement, (LCD refresh Left to Right, when MADCTL (36h) D2='0') '1' =Increment, (LCD refresh Right to Left, when MADCTL (36h) D2='1') | | | | | | | | | |
| | ST24 | For Future Use | | '0' | | | | | | | | | |
| | ST23 | For Future Use | | '0' | | | | | | | | | |
| | IFPF2 | Interface Color | | "011" = 12-bit / pixel, | | | | | | | | | |
| | IFPF1 | Pixel Format | | "101" = 16-bit / pixel, | | | | | | | | | |
| | IFPF0 | Definition | | "110" = 18-bit / pixel, others are no define | | | | | | | | | |
| | IDMON | Idle Mode On/Off | | '1' = On, "0" = Off | | | | | | | | | |
| | PTLON | Partial Mode | | '1' = On, "0" = Off | | | | | | | | | |
| | SLPOUT | Sleep In/Out | | '1' = Out, "0" = In | | | | | | | | | |
| | NORON | Display Normal Mode On/Off | | '1' = Normal Display, '0' = Partial Display | | | | | | | | | |
| | ST15 | Vertical Scrolling | | '1' = Scroll on,"0" = Scroll off | | | | | | | | | |
| | ST14 | Horizontal Scroll | | '0' | | | | | | | | | |
| | INVON | Inversion Status | | '1' = On, "0" = Off | | | | | | | | | |
| | ST12 | All Pixels On (Not | | '0' | | | | | | | | | |
| | ST11 | All Pixels Off (Not | | '0' | | | | | | | | | |
| | DISON | Display On/Off | | '1' = On, "0" = Off | | | | | | | | | |
| | TEON | Tearing effect line | | '1' = On, "0" = Off | | | | | | | | | |
| | GCSEL2 | Gamma Curve Selection | | "000" = GC0 | | | | | | | | | |
| | GCSEL1 | | | "001" = GC1 | | | | | | | | | |
| | GCSEL0 | | | "010" = GC2 "011" = GC3 | | | | | | | | | |

| | | |
|-----|---------------------|--------------------------|
| TEM | Tearing effect line | '0' = mode1, '1' = mode2 |
| ST4 | For Future Use | '0' |
| ST3 | For Future Use | '0' |
| ST2 | For Future Use | '0' |
| ST1 | For Future Use | '0' |
| ST0 | For Future Use | '0' |

"-" Don't care

| Status | Default Value (ST31 to ST0) | | | |
|-------------------|-----------------------------|-----------|-----------|-----------|
| | ST[31-24] | ST[23-16] | ST[15-8] | ST[7-0] |
| Power On Sequence | 0000-0000 | 0110-0001 | 0000-0000 | 0000-0000 |
| S/W Reset | 0xxx0xx00 | 0xxx-0001 | 0000-0000 | 0000-0000 |
| H/W Reset | 0000-0000 | 0110-0001 | 0000-0000 | 0000-0000 |

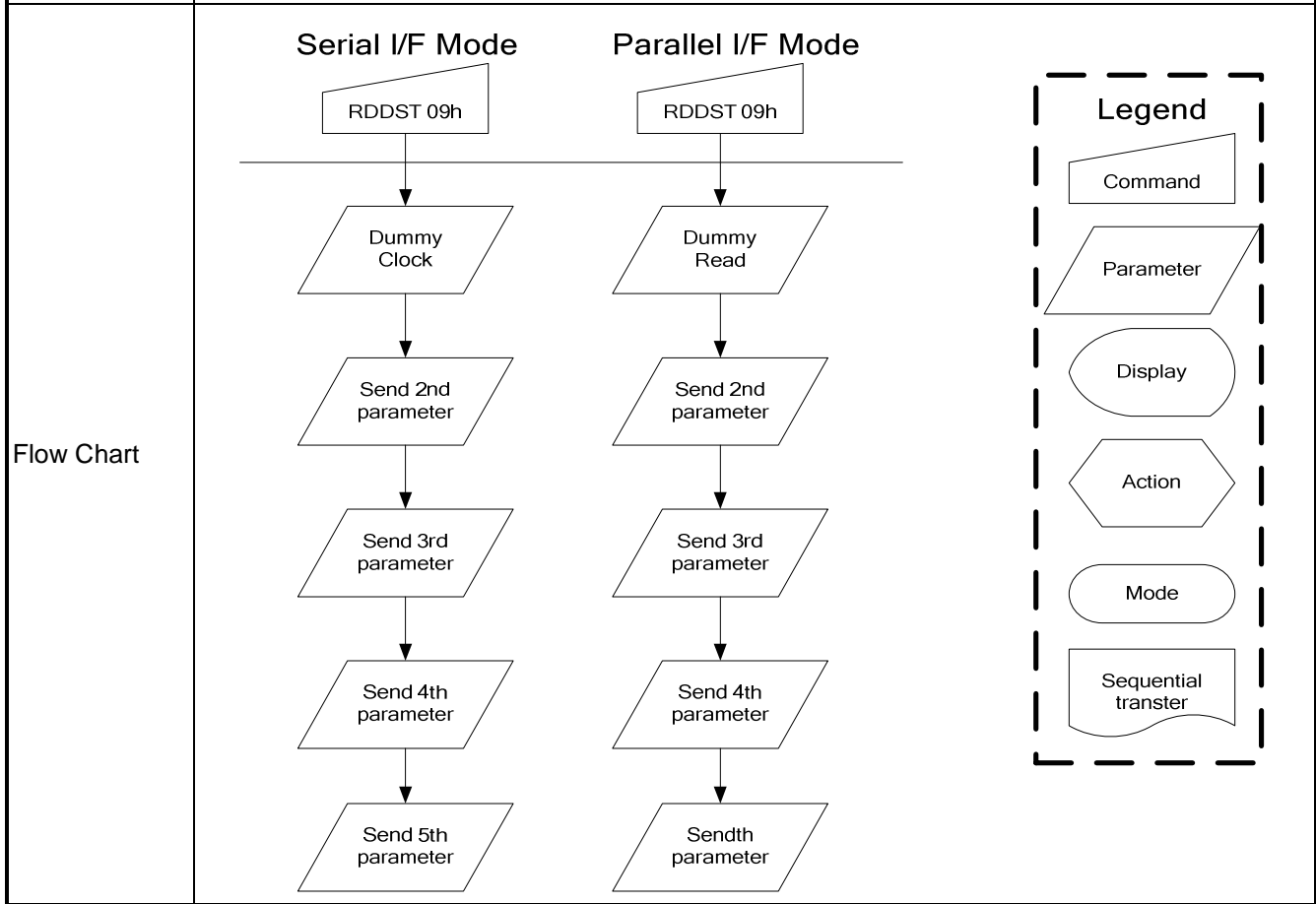

10.1.5 RDDPM (0Ah): Read Display Power Mode

| 0AH | RDDPM (Read Display Power Mode) | | | | | | | | | | | | |
|---------------------------|---------------------------------|-----|-----|-------|-------|-------|-------|--------|-------|-------|----|----|-------|
| Inst / Para | D/CX | WRX | RDX | D17-8 | D7 | D6 | D5 | D4 | D3 | D2 | D1 | D0 | HEX |
| RDDPM | 0 | ↑ | 1 | - | 0 | 0 | 0 | 0 | 1 | 0 | 1 | 0 | (0Ah) |
| 1 st Parameter | 1 | 1 | ↑ | - | - | - | - | - | - | - | - | - | - |
| 2 nd Parameter | 1 | 1 | ↑ | | BSTON | IDMON | PTLON | SLPOUT | NORON | DISON | D1 | D0 | |

This command indicates the current status of the display as described in the table below:
 “-“ Don't care

| Bit | Description | Value |
|-------|----------------------------|--|
| BSTON | Booster Voltage Status | '1' =Booster on, '0' =Booster off |
| IDMON | Idle Mode On/Off | '1' = Idle Mode On, '0' = Idle Mode Off |
| PTLON | Partial Mode On/Off | '1' = Partial Mode On, '0' = Partial Mode Off |
| SLPON | Sleep In/Out | '1' = Sleep Out, '0' = Sleep In |
| NORON | Display Normal Mode On/Off | '1' = Normal Display, '0' = Partial Display |
| DISON | Display On/Off | '1' = Display On, '0' = Display Off |
| D1 | Not Used | '0' |
| D0 | Not Used | '0' |

Default

| Status | Default Value (D7 to D0) |
|-------------------|--------------------------|
| Power On Sequence | 0000_1000(08h) |
| S/W Reset | 0000_1000(08h) |
| H/W Reset | 0000_1000(08h) |

Flow Chart

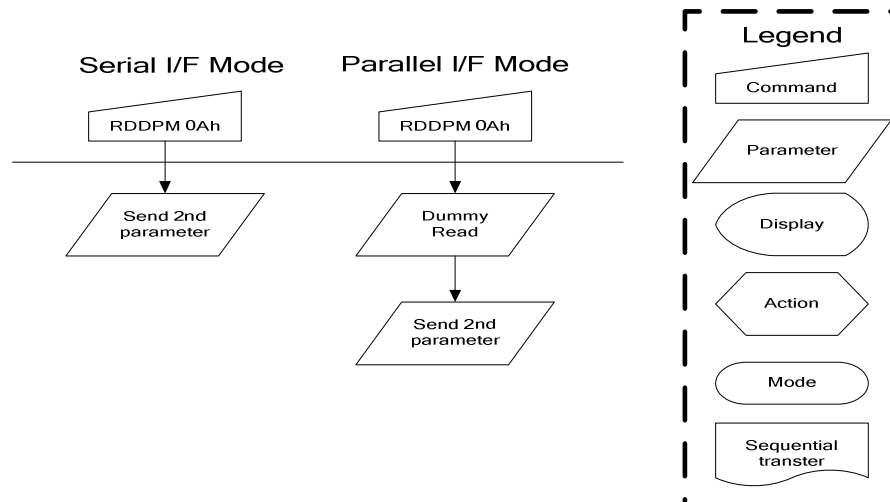

10.1.6 RDDMADCTL (0Bh): Read Display MADCTL

| 0BH | RDDMADCTL (Read Display MADCTL) | | | | | | | | | | | | |
|---------------------------|---------------------------------|-----|-----|-------|----|----|----|----|-----|----|----|----|-------|
| Inst / Para | D/CX | WRX | RDX | D17-8 | D7 | D6 | D5 | D4 | D3 | D2 | D1 | D0 | HEX |
| RDDMADCTL | 0 | ↑ | 1 | - | 0 | 0 | 0 | 0 | 1 | 0 | 1 | 1 | (0Bh) |
| 1 st Parameter | 1 | 1 | ↑ | - | - | - | - | - | - | - | - | - | - |
| 2 nd Parameter | 1 | 1 | ↑ | | MY | MX | MV | ML | RGB | MH | D1 | D0 | |

| | | | | | | | | | | | | | |
|-------------|---|--------------------------|-------------|--|--|--|--|-------|--|--|--|--|--|
| Description | This command indicates the current status of the display as described in the table below: “-“ Don't care | | | | | | | | | | | | |
| | Bit | | Description | | | | | Value | | | | | |
| | MX | Column Address Order | | | | | '1' = Right to Left (When MADCTL B6='1') '0' = Left to Right (When MADCTL B6='0') | | | | | | |
| | MY | Row Address Order | | | | | '1' = Bottom to Top (When MADCTL B7='1') '0' = Top to Bottom (When MADCTL B7='0') | | | | | | |
| | MV | Row/Column Order (MV) | | | | | '1' = Row/column exchange (MV=1) '0' = Normal (MV=0) | | | | | | |
| | ML | Vertical Refresh Order | | | | | '1' =LCD Refresh Bottom to Top '0' =LCD Refresh Top to Bottom | | | | | | |
| | RGB | RGB/BGR Order | | | | | '1' =BGR, "0"=RGB | | | | | | |
| | MH | Horizontal Refresh Order | | | | | LCD horizontal refresh direction control '0' = LCD horizontal refresh Left to right '1' = LCD horizontal refresh right to left | | | | | | |
| | D1 | Not Used | | | | | '0' | | | | | | |
| | D0 | Not Used | | | | | '0' | | | | | | |

| | | | | |
|---------|-------------------|--|--------------------------|--|
| Default | Status | | Default Value (D7 to D0) | |
| | Power On Sequence | | 0000_0000 (00h) | |
| | S/W Reset | | No change | |
| | H/W Reset | | 0000_0000 (00h) | |

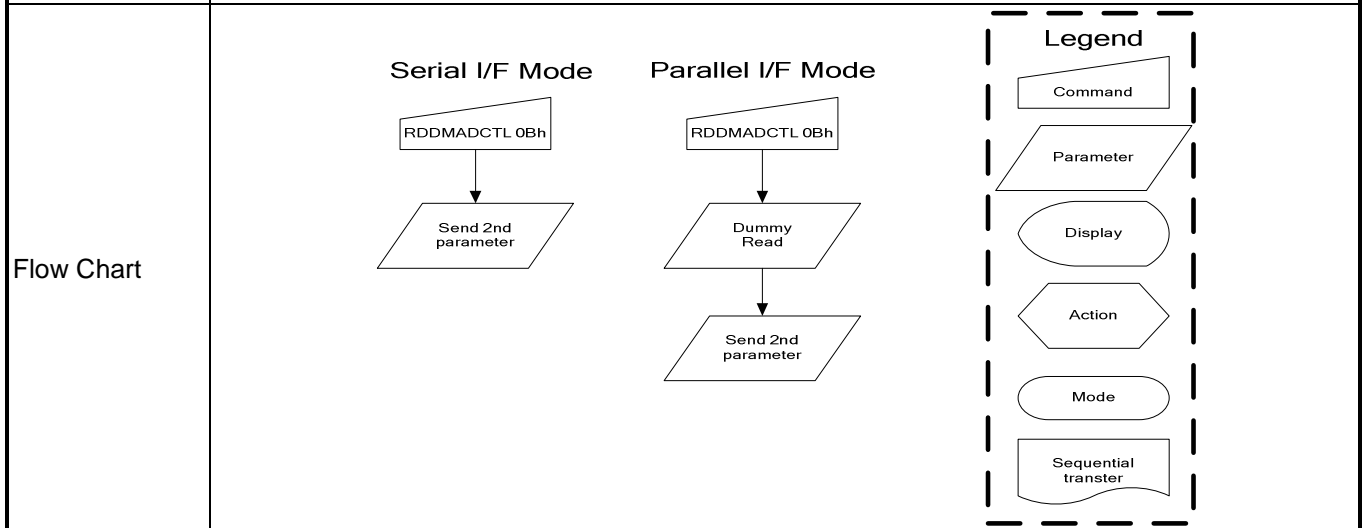

10.1.7 RDDCOLMOD (0Ch): Read Display Pixel Format

| 0CH | RDDCOLMOD (Read Display Pixel Format) | | | | | | | | | | | | |
|--|---|---------|----------------------------|-------|----|----|----|----|----|-------|-------|-------|-------|
| Inst / Para | D/CX | WRX | RDX | D17-8 | D7 | D6 | D5 | D4 | D3 | D2 | D1 | D0 | HEX |
| RDDCOLMOD | 0 | ↑ | 1 | - | 0 | 0 | 0 | 0 | 1 | 1 | 0 | 0 | (0Ch) |
| 1 st Parameter | 1 | 1 | ↑ | - | - | - | - | - | - | - | - | - | - |
| 2 nd Parameter | 1 | 1 | ↑ | - | 0 | 0 | 0 | 0 | - | IFPF2 | IFPF1 | IFPF0 | |
| Description | This command indicates the current status of the display as described in the table below: | | | | | | | | | | | | |
| | IFPF[2:0] | | MCU Interface Color Format | | | | | | | | | | |
| | 011 | | 12-bit/pixel | | | | | | | | | | |
| | 101 | | 16-bit/pixel | | | | | | | | | | |
| | 110 | | 18-bit/pixel | | | | | | | | | | |
| 111 | | No used | | | | | | | | | | | |
| Others are no define and invalid “-“ Don't care | | | | | | | | | | | | | |
| Default | Status | | Default Value | | | | | | | | | | |
| | | | IFPF[2:0] | | | | | | | | | | |
| | Power On Sequence | | 0110 (18 bits/pixel) | | | | | | | | | | |
| | S/W Reset | | No Change | | | | | | | | | | |
| | H/W Reset | | 0110 (18 bits/pixel) | | | | | | | | | | |
| Flow Chart | Serial I/F Mode | | Parallel I/F Mode | | | | | | | | | | |
| | | | | | | | | | | | | | |

10.1.8 RDDIM (0Dh): Read Display Image Mode

| 0DH | RDDIM (0Dh): Read Display Image Mode | | | | | | | | | | | | | | | | | | | | | | | | | | | | | | | | |
|---------------------------|--|---|-----|-------|-------|----|-------|----|----|------|------|------|-------|--------|-------------------------|-------------------|-----------------|-----------|-----------------|-----------|-----------------|-----|-------|------------------|--|----|---------------|----------------|----|----------------|----------------|----------------------|-----------------------|
| Inst / Para | D/CX | WRX | RDX | D17-8 | D7 | D6 | D5 | D4 | D3 | D2 | D1 | D0 | HEX | | | | | | | | | | | | | | | | | | | | |
| RDDIM | 0 | ↑ | 1 | - | 0 | 0 | 0 | 0 | 1 | 1 | 0 | 1 | (0Dh) | | | | | | | | | | | | | | | | | | | | |
| 1 st Parameter | 1 | 1 | ↑ | - | - | - | - | - | - | - | - | - | - | | | | | | | | | | | | | | | | | | | | |
| 2 nd Parameter | 1 | 1 | ↑ | - | VSSON | D6 | INVON | D4 | D3 | GCS2 | GCS1 | GCS0 | | | | | | | | | | | | | | | | | | | | | |
| Description | This command indicates the current status of the display as described in the table below: "-": Don't care | | | | | | | | | | | | | | | | | | | | | | | | | | | | | | | | |
| | <table border="1"> <thead> <tr> <th>Bit</th> <th>Description</th> <th>Value</th> </tr> </thead> <tbody> <tr> <td>VSSON</td> <td>Reversed</td> <td>"0"</td> </tr> <tr> <td>D6</td> <td>Reversed</td> <td>"0"</td> </tr> <tr> <td>INVON</td> <td>Inversion On/Off</td> <td>"1" = Inversion is On, "0" = Inversion is Off</td> </tr> <tr> <td>D4</td> <td>All Pixels On</td> <td>"0" (Not used)</td> </tr> <tr> <td>D3</td> <td>All Pixels Off</td> <td>"0" (Not used)</td> </tr> <tr> <td>GCS2 GCS1 GCS0</td> <td>Gamma Curve Selection</td> <td>"000" = GC0, "001" = GC1, "010" = GC2, "011" = GC3, "100" to "111" = Not defined</td> </tr> </tbody> </table> | | | | | | | | | | | | | Bit | Description | Value | VSSON | Reversed | "0" | D6 | Reversed | "0" | INVON | Inversion On/Off | "1" = Inversion is On, "0" = Inversion is Off | D4 | All Pixels On | "0" (Not used) | D3 | All Pixels Off | "0" (Not used) | GCS2 GCS1 GCS0 | Gamma Curve Selection |
| Bit | Description | Value | | | | | | | | | | | | | | | | | | | | | | | | | | | | | | | |
| VSSON | Reversed | "0" | | | | | | | | | | | | | | | | | | | | | | | | | | | | | | | |
| D6 | Reversed | "0" | | | | | | | | | | | | | | | | | | | | | | | | | | | | | | | |
| INVON | Inversion On/Off | "1" = Inversion is On, "0" = Inversion is Off | | | | | | | | | | | | | | | | | | | | | | | | | | | | | | | |
| D4 | All Pixels On | "0" (Not used) | | | | | | | | | | | | | | | | | | | | | | | | | | | | | | | |
| D3 | All Pixels Off | "0" (Not used) | | | | | | | | | | | | | | | | | | | | | | | | | | | | | | | |
| GCS2 GCS1 GCS0 | Gamma Curve Selection | "000" = GC0, "001" = GC1, "010" = GC2, "011" = GC3, "100" to "111" = Not defined | | | | | | | | | | | | | | | | | | | | | | | | | | | | | | | |
| Default | <table border="1"> <thead> <tr> <th>Status</th> <th>Default Value(D7 to D0)</th> </tr> </thead> <tbody> <tr> <td>Power On Sequence</td> <td>0000_0000 (00h)</td> </tr> <tr> <td>S/W Reset</td> <td>0000_0000 (00h)</td> </tr> <tr> <td>H/W Reset</td> <td>0000_0000 (00h)</td> </tr> </tbody> </table> | | | | | | | | | | | | | Status | Default Value(D7 to D0) | Power On Sequence | 0000_0000 (00h) | S/W Reset | 0000_0000 (00h) | H/W Reset | 0000_0000 (00h) | | | | | | | | | | | | |
| | Status | Default Value(D7 to D0) | | | | | | | | | | | | | | | | | | | | | | | | | | | | | | | |
| Power On Sequence | 0000_0000 (00h) | | | | | | | | | | | | | | | | | | | | | | | | | | | | | | | | |
| S/W Reset | 0000_0000 (00h) | | | | | | | | | | | | | | | | | | | | | | | | | | | | | | | | |
| H/W Reset | 0000_0000 (00h) | | | | | | | | | | | | | | | | | | | | | | | | | | | | | | | | |
| Flow Chart | <div style="display: flex; justify-content: space-around;"> <div style="text-align: center;"> <p>Serial I/F Mode</p> </div> <div style="text-align: center;"> <p>Parallel I/F Mode</p> </div> </div> <div style="margin-top: 20px;"> <p>Host Display</p> </div> <div style="border: 1px dashed black; padding: 5px; margin-top: 20px;"> <p>Legend</p> <ul style="list-style-type: none"> Command Parameter Display Action Mode Sequential transfer </div> | | | | | | | | | | | | | | | | | | | | | | | | | | | | | | | | |

10.1.9 RDDSM (0Eh): Read Display Signal Mode

| 0EH | RDDSM (0Eh): Read Display Signal Mode | | | | | | | | | | | | | | | | | | | | | | | | | | | | | | | | | | | | | | | |
|---------------------------|---|----------------------------|-----------------------------|-------|------|-----|----|----|----|----|----|----|-------|--------|----------------------|-------------------|-----------------|----------------------------|------------------------|-----------|--------------------------|-----------------------------|----|----------|------------------------|----|----------|------------------------|----|----------|------------------------|----|----------|------------------------|----|----------|------------------------|----|----------|------------------------|
| Inst / Para | D/CX | WRX | RDX | D17-8 | D7 | D6 | D5 | D4 | D3 | D2 | D1 | D0 | HEX | | | | | | | | | | | | | | | | | | | | | | | | | | | |
| RDDSM | 0 | ↑ | 1 | - | 0 | 0 | 0 | 0 | 1 | 1 | 1 | 0 | (0Eh) | | | | | | | | | | | | | | | | | | | | | | | | | | | |
| 1 st Parameter | 1 | 1 | ↑ | - | - | - | - | - | - | - | - | - | - | | | | | | | | | | | | | | | | | | | | | | | | | | | |
| 2 nd Parameter | 1 | 1 | ↑ | - | TEON | TEM | D5 | D4 | D3 | D2 | D1 | D0 | | | | | | | | | | | | | | | | | | | | | | | | | | | | |
| Description | This command indicates the current status of the display as described in the table below: “-“ Don't care | | | | | | | | | | | | | | | | | | | | | | | | | | | | | | | | | | | | | | | |
| | <table border="1"> <thead> <tr> <th>Bit</th> <th>Description</th> <th>Value</th> </tr> </thead> <tbody> <tr> <td>TEON</td> <td>Tearing Effect Line On/Off</td> <td>“1” = On, “0” = Off</td> </tr> <tr> <td>TEM</td> <td>Tearing effect line mode</td> <td>“1” = Mode2, “0” = Mode1</td> </tr> <tr> <td>D5</td> <td>Not Used</td> <td>“1” = On, “0” = Off</td> </tr> <tr> <td>D4</td> <td>Not Used</td> <td>“1” = On, “0” = Off</td> </tr> <tr> <td>D3</td> <td>Not Used</td> <td>“1” = On, “0” = Off</td> </tr> <tr> <td>D2</td> <td>Not Used</td> <td>“1” = On, “0” = Off</td> </tr> <tr> <td>D1</td> <td>Not Used</td> <td>“1” = On, “0” = Off</td> </tr> <tr> <td>D0</td> <td>Not Used</td> <td>“1” = On, “0” = Off</td> </tr> </tbody> </table> | | | | | | | | | | | | | Bit | Description | Value | TEON | Tearing Effect Line On/Off | “1” = On, “0” = Off | TEM | Tearing effect line mode | “1” = Mode2, “0” = Mode1 | D5 | Not Used | “1” = On, “0” = Off | D4 | Not Used | “1” = On, “0” = Off | D3 | Not Used | “1” = On, “0” = Off | D2 | Not Used | “1” = On, “0” = Off | D1 | Not Used | “1” = On, “0” = Off | D0 | Not Used | “1” = On, “0” = Off |
| | Bit | Description | Value | | | | | | | | | | | | | | | | | | | | | | | | | | | | | | | | | | | | | |
| | TEON | Tearing Effect Line On/Off | “1” = On, “0” = Off | | | | | | | | | | | | | | | | | | | | | | | | | | | | | | | | | | | | | |
| | TEM | Tearing effect line mode | “1” = Mode2, “0” = Mode1 | | | | | | | | | | | | | | | | | | | | | | | | | | | | | | | | | | | | | |
| | D5 | Not Used | “1” = On, “0” = Off | | | | | | | | | | | | | | | | | | | | | | | | | | | | | | | | | | | | | |
| | D4 | Not Used | “1” = On, “0” = Off | | | | | | | | | | | | | | | | | | | | | | | | | | | | | | | | | | | | | |
| | D3 | Not Used | “1” = On, “0” = Off | | | | | | | | | | | | | | | | | | | | | | | | | | | | | | | | | | | | | |
| | D2 | Not Used | “1” = On, “0” = Off | | | | | | | | | | | | | | | | | | | | | | | | | | | | | | | | | | | | | |
| | D1 | Not Used | “1” = On, “0” = Off | | | | | | | | | | | | | | | | | | | | | | | | | | | | | | | | | | | | | |
| D0 | Not Used | “1” = On, “0” = Off | | | | | | | | | | | | | | | | | | | | | | | | | | | | | | | | | | | | | | |
| Default | <table border="1"> <thead> <tr> <th>Status</th> <th>Default Value(D7~D0)</th> </tr> </thead> <tbody> <tr> <td>Power On Sequence</td> <td>0000_0000 (00h)</td> </tr> <tr> <td>S/W Reset</td> <td>0000_0000 (00h)</td> </tr> <tr> <td>H/W Reset</td> <td>0000_0000 (00h)</td> </tr> </tbody> </table> | | | | | | | | | | | | | Status | Default Value(D7~D0) | Power On Sequence | 0000_0000 (00h) | S/W Reset | 0000_0000 (00h) | H/W Reset | 0000_0000 (00h) | | | | | | | | | | | | | | | | | | | |
| | Status | Default Value(D7~D0) | | | | | | | | | | | | | | | | | | | | | | | | | | | | | | | | | | | | | | |
| | Power On Sequence | 0000_0000 (00h) | | | | | | | | | | | | | | | | | | | | | | | | | | | | | | | | | | | | | | |
| | S/W Reset | 0000_0000 (00h) | | | | | | | | | | | | | | | | | | | | | | | | | | | | | | | | | | | | | | |
| H/W Reset | 0000_0000 (00h) | | | | | | | | | | | | | | | | | | | | | | | | | | | | | | | | | | | | | | | |

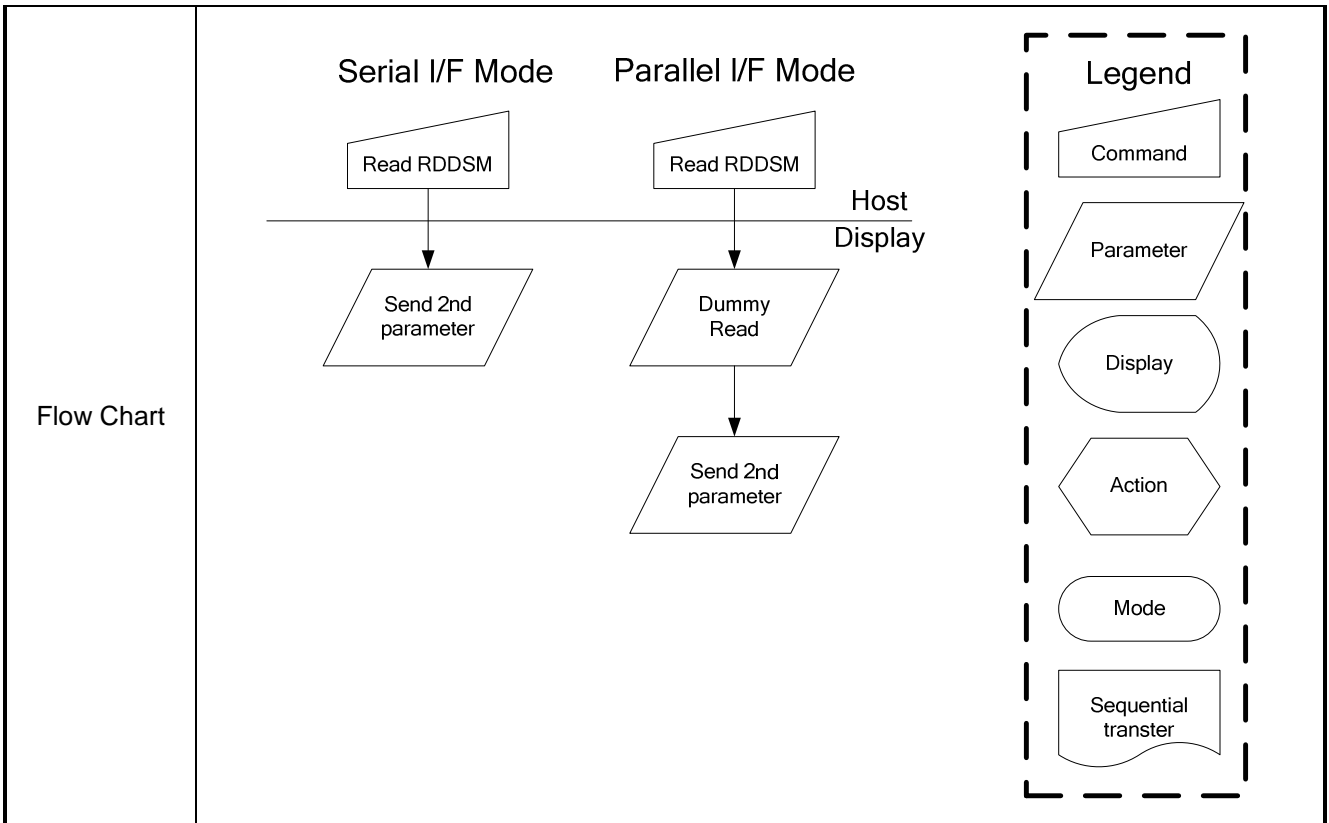

10.1.10 RDDSDR (0Fh): Read Display Self-Diagnostic Result

| 0FH | RDDSDR (0Fh): Read Display Self-Diagnostic Result | | | | | | | | | | | | |
|---------------------------|---|-----|-------------------------------|-------|--|----------------------|------|-----|---|--------------------|----|----|-------|
| Inst / Para | D/CX | WRX | RDX | D17-8 | D7 | D6 | D5 | D4 | D3 | D2 | D1 | D0 | HEX |
| RDDSDR | 0 | ↑ | 1 | - | 0 | 0 | 0 | 0 | 1 | 1 | 1 | 1 | (0Fh) |
| 1 st Parameter | 1 | 1 | ↑ | - | - | - | - | - | - | - | - | - | - |
| 2 nd Parameter | 1 | 1 | ↑ | - | RELD | FUND | ATTD | BRD | D3 | D2 | D1 | D0 | |
| Description | This command indicates the current status of the display as described in the table below: “-“ Don't care | | | | | | | | | | | | |
| | Bit | | Description | | | | | | | Value | | | |
| | RELD | | Register Loading Detection | | | | | | | See Section 9.19.1 | | | |
| | FUND | | Functionality Detection | | | | | | | See Section 9.19.2 | | | |
| | ATTD | | Chip Attachment Detection | | | | | | | See Section 9.19.3 | | | |
| | BRD | | Display Glass Break Detection | | | | | | | See Section 9.19.4 | | | |
| | D3 | | Not Used | | | | | | | "0" | | | |
| | D2 | | Not Used | | | | | | | "0" | | | |
| | D1 | | Not Used | | | | | | | "0" | | | |
| | D0 | | Not Used | | | | | | | "0" | | | |
| Default | Status | | | | | Default Value(D7~D0) | | | | | | | |
| | Power On Sequence | | | | | 0000_0000 (00h) | | | | | | | |
| | SW Reset | | | | | 0000_0000 (00h) | | | | | | | |
| | HW Reset | | | | | 0000_0000 (00h) | | | | | | | |
| Flow Chart | Serial I/F Mode | | | | Parallel I/F Mode | | | | <div style="border: 1px dashed black; padding: 5px;"> <p>Legend</p> <p>Command</p> <p>Parameter</p> <p>Display</p> <p>Action</p> <p>Mode</p> <p>Sequential transfer</p> </div> | | | | |
| | <p>Read RDDSDR</p> <p>↓</p> <p>Send 2nd parameter</p> | | | | <p>Read RDDSDR</p> <p>↓</p> <p>Dummy Read</p> <p>↓</p> <p>Send 2nd parameter</p> | | | | | | | | |

10.1.11 SLPIN (10h): Sleep In

| 10H | SLPIN (Sleep In) | | | | | | | | | | | | | | | | | | | |
|-------------------|---|-----|-----|-------|----|----|----|----|----|----|----|----|--------|---------------|-------------------|---------------|-----------|---------------|-----------|---------------|
| Inst / Para | D/CX | WRX | RDX | D17-8 | D7 | D6 | D5 | D4 | D3 | D2 | D1 | D0 | HEX | | | | | | | |
| SLPIN | 0 | ↑ | 1 | - | 0 | 0 | 0 | 1 | 0 | 0 | 0 | 0 | (10h) | | | | | | | |
| Parameter | No Parameter | | | | | | | | | | | | - | | | | | | | |
| Description | -This command causes the LCD module to enter the minimum power consumption mode. -In this mode the DC/DC converter is stopped, Internal display oscillator is stopped, and panel scanning is stopped. | | | | | | | | | | | | | | | | | | | |
| Restriction | -This command has no effect when module is already in Sleep In mode. Sleep In Mode can only be exit by the Sleep Out Command (11h). -When IC is in Sleep Out or Display On mode, it is necessary to wait 120msec before sending next command because of the stabilization timing for the supply voltages and clock circuits. | | | | | | | | | | | | | | | | | | | |
| Default | <table border="1"> <thead> <tr> <th>Status</th> <th>Default Value</th> </tr> </thead> <tbody> <tr> <td>Power On Sequence</td> <td>Sleep In Mode</td> </tr> <tr> <td>S/W Reset</td> <td>Sleep In Mode</td> </tr> <tr> <td>H/W Reset</td> <td>Sleep in Mode</td> </tr> </tbody> </table> | | | | | | | | | | | | Status | Default Value | Power On Sequence | Sleep In Mode | S/W Reset | Sleep In Mode | H/W Reset | Sleep in Mode |
| Status | Default Value | | | | | | | | | | | | | | | | | | | |
| Power On Sequence | Sleep In Mode | | | | | | | | | | | | | | | | | | | |
| S/W Reset | Sleep In Mode | | | | | | | | | | | | | | | | | | | |
| H/W Reset | Sleep in Mode | | | | | | | | | | | | | | | | | | | |
| Flow Chart | | | | | | | | | | | | | | | | | | | | |

10.1.12 SLPOUT (11h): Sleep Out

| 11H | SLPOUT (Sleep Out) | | | | | | | | | | | | | | | | | | | |
|-------------------|--|-----|-----|-------|----|----|----|----|----|----|----|----|--------|---------------|-------------------|---------------|----------|---------------|-----------|---------------|
| Inst / Para | D/CX | WRX | RDX | D17-8 | D7 | D6 | D5 | D4 | D3 | D2 | D1 | D0 | HEX | | | | | | | |
| SLPOUT | 0 | ↑ | 1 | - | 0 | 0 | 0 | 1 | 0 | 0 | 0 | 1 | (11h) | | | | | | | |
| Parameter | No Parameter | | | | | | | | | | | | - | | | | | | | |
| Description | -This command turns off sleep mode. -In this mode the DC/DC converter is enabled, Internal display oscillator is started, and panel scanning is started. | | | | | | | | | | | | | | | | | | | |
| Restriction | -This command has no effect when module is already in sleep out mode. Sleep Out Mode can only be exit by the Sleep In Command (10h). -When IC is in Sleep In mode, it is necessary to wait 120msec before sending next command because of the stabilization timing for the supply voltages and clock circuits. -When IC is in Sleep Out or Display On mode, it is necessary to wait 120msec before sending next command due to the download of default value of registers and the execution of self-diagnostic function. | | | | | | | | | | | | | | | | | | | |
| Default | <table border="1"> <thead> <tr> <th>Status</th> <th>Default Value</th> </tr> </thead> <tbody> <tr> <td>Power On Sequence</td> <td>Sleep In Mode</td> </tr> <tr> <td>SW Reset</td> <td>Sleep In Mode</td> </tr> <tr> <td>H/W Reset</td> <td>Sleep in Mode</td> </tr> </tbody> </table> | | | | | | | | | | | | Status | Default Value | Power On Sequence | Sleep In Mode | SW Reset | Sleep In Mode | H/W Reset | Sleep in Mode |
| Status | Default Value | | | | | | | | | | | | | | | | | | | |
| Power On Sequence | Sleep In Mode | | | | | | | | | | | | | | | | | | | |
| SW Reset | Sleep In Mode | | | | | | | | | | | | | | | | | | | |
| H/W Reset | Sleep in Mode | | | | | | | | | | | | | | | | | | | |
| Flow Chart | | | | | | | | | | | | | | | | | | | | |

10.1.13 PTLON (12h): Partial Display Mode On

| 12H | PTLON (12h): Partial Display Mode On | | | | | | | | | | | | |
|-------------|---|-----|-----|-------|----|----|----------------|----|----|----|----|----|-------|
| Inst / Para | D/CX | WRX | RDX | D17-8 | D7 | D6 | D5 | D4 | D3 | D2 | D1 | D0 | HEX |
| PTLON | 0 | ↑ | 1 | - | 0 | 0 | 0 | 1 | 0 | 0 | 1 | 0 | (12h) |
| Parameter | No Parameter | | | | | | | | | | | | - |
| Description | -This command turns on Partial mode. The partial mode window is described by the Partial Area command (30h) -To leave Partial mode, the Normal Display Mode On command (13h) should be written. "- Don't care | | | | | | | | | | | | |
| Default | Status | | | | | | Default Value | | | | | | |
| | Power On Sequence | | | | | | Normal Mode On | | | | | | |
| | S/W Reset | | | | | | Normal Mode On | | | | | | |
| | H/W Reset | | | | | | Normal Mode On | | | | | | |
| Flow Chart | See Partial Area (30h) | | | | | | | | | | | | |



10.1.14 NORON (13h): Normal Display Mode On

| 13H | NORON (Normal Display Mode On) | | | | | | | | | | | | |
|-------------|--|-----|-----|-------|----|----|----------------|----|----|----|----|----|-------|
| Inst / Para | D/CX | WRX | RDX | D17-8 | D7 | D6 | D5 | D4 | D3 | D2 | D1 | D0 | HEX |
| NORON | 0 | ↑ | 1 | - | 0 | 0 | 0 | 1 | 0 | 0 | 1 | 1 | (13h) |
| Parameter | No Parameter | | | | | | | | | | | | - |
| Description | -This command returns the display to normal mode. -Normal display mode on means Partial mode off. -Exit from NORON by the Partial mode On command (12h) "- Don't care | | | | | | | | | | | | |
| Default | Status | | | | | | Default Value | | | | | | |
| | Power On Sequence | | | | | | Normal Mode On | | | | | | |
| | S/W Reset | | | | | | Normal Mode On | | | | | | |
| | H/W Reset | | | | | | Normal Mode On | | | | | | |
| Flow Chart | See Partial Area Definition Descriptions for details of when to use this command | | | | | | | | | | | | |

10.1.15 INVOFF (20h): Display Inversion Off

| 20H | IVNOFF (Normal Display Mode Off) | | | | | | | | | | | | HEX |
|-------------|--|-----|-----|-------|----|----|-----------------------|----|----|----|----|----|-------|
| Inst / Para | D/CX | WRX | RDX | D17-8 | D7 | D6 | D5 | D4 | D3 | D2 | D1 | D0 | HEX |
| INVOFF | 0 | ↑ | 1 | - | 0 | 0 | 1 | 0 | 0 | 0 | 0 | 0 | (20h) |
| Parameter | No Parameter | | | | | | | | | | | | - |
| Description | <p>-This command is used to recover from display inversion mode. "- Don't care</p> <p>(Example)</p> | | | | | | | | | | | | |
| Default | Status | | | | | | Default Value | | | | | | |
| | Power On Sequence | | | | | | Display Inversion off | | | | | | |
| | S/W Reset | | | | | | Display Inversion off | | | | | | |
| | H/W Reset | | | | | | Display Inversion off | | | | | | |
| Flow Chart | | | | | | | | | | | | | |

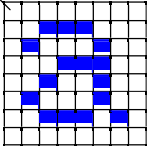
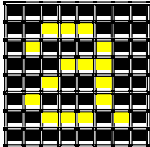
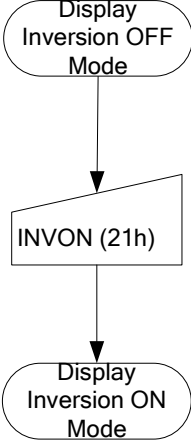
10.1.16 INVON (21h): Display Inversion On

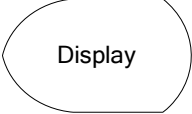
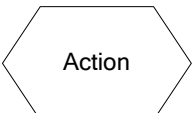
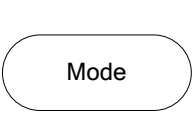
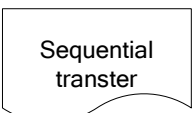
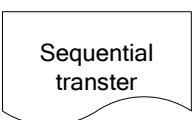
| 21H | IVNOFF (Display Inversion On) | | | | | | | | | | | | |
|-------------|---|-----|-----|-------|----|----|-----------------------|----|----|----|----|----|-------|
| Inst / Para | D/CX | WRX | RDX | D17-8 | D7 | D6 | D5 | D4 | D3 | D2 | D1 | D0 | HEX |
| INVON | 0 | ↑ | 1 | - | 0 | 0 | 1 | 0 | 0 | 0 | 0 | 1 | (21h) |
| Parameter | No Parameter | | | | | | | | | | | | |
| Description | <p>-This command is used to enter into display inversion mode -To exit from Display Inversion On, the Display Inversion Off command (20h) should be written. "- Don't care (Example)</p> <div style="display: flex; align-items: center; justify-content: center;"> <div style="text-align: center;"> <p>Top-Left (0,0)</p>  <p>Memory</p> </div> <div style="margin: 0 20px;">  </div> <div style="text-align: center;">  <p>Display</p> </div> </div> | | | | | | | | | | | | |
| Default | Status | | | | | | Default Value | | | | | | |
| | Power On Sequence | | | | | | Display Inversion off | | | | | | |
| | S/W Reset | | | | | | Display Inversion off | | | | | | |
| | H/W Reset | | | | | | Display Inversion off | | | | | | |
| Flow Chart | <div style="display: flex; justify-content: space-between;"> <div style="width: 45%;">  </div> <div style="width: 45%; border: 1px dashed black; padding: 5px;"> <p style="text-align: center;">Legend</p> <ul style="list-style-type: none">  Command  Parameter  Display  Action  Mode  Sequential transfer </div> </div> | | | | | | | | | | | | |

10.1.17 GAMSET (26h): Gamma Set

| 26H | GAMSET (Gamma Set) | | | | | | | | | | | | |
|-------------|--------------------|-----|-----|-------|----|----|----|----|-----|-----|-----|-----|-------|
| Inst / Para | D/CX | WRX | RDX | D17-8 | D7 | D6 | D5 | D4 | D3 | D2 | D1 | D0 | HEX |
| GAMSET | 0 | ↑ | 1 | - | 0 | 0 | 1 | 0 | 0 | 1 | 1 | 0 | (26h) |
| Parameter | 1 | ↑ | 1 | - | - | - | - | - | GC3 | GC2 | GC1 | GC0 | |

-This command is used to select the desired Gamma curve for the current display. A maximum of 4 curves can be selected. The curve is selected by setting the appropriate bit in the parameter as described in the Table.





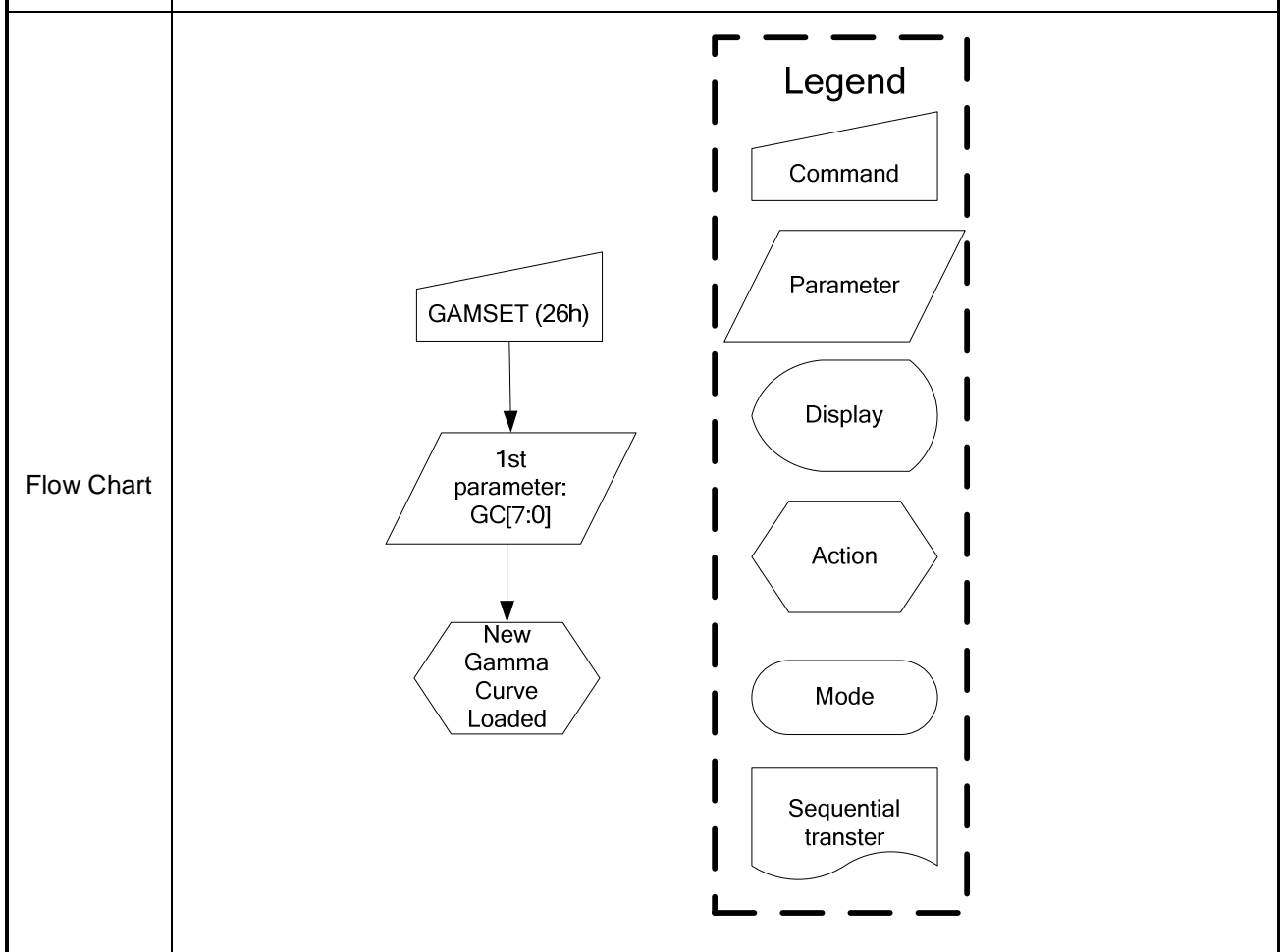

| GC [7:0] | Parameter | Curve Selected | |
|----------|-----------|----------------------|----------------------|
| | | GS=1 | GS=0 |
| 01h | GC0 | Gamma Curve 1 (G2.2) | Gamma Curve 1 (G1.0) |
| 02h | GC1 | Gamma Curve 2 (G1.8) | Gamma Curve 2 (G2.5) |
| 04h | GC2 | Gamma Curve 3 (G2.5) | Gamma Curve 3 (G2.2) |
| 08h | GC3 | Gamma Curve 4 (G1.0) | Gamma Curve 4 (G1.8) |

Note: All other values are undefined.

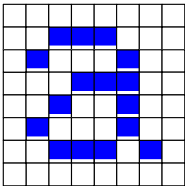
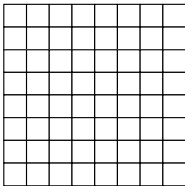
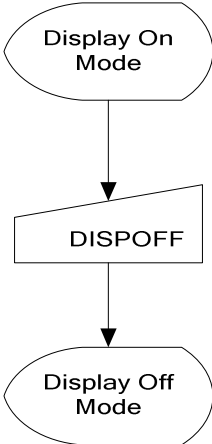
| Default | Status | Default Value |
|---------|-------------------|---------------|
| | Power On Sequence | 01h |
| | S/W Reset | 01h |
| | H/W Reset | 01h |

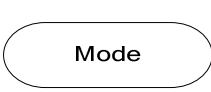

10.1.18 DISPOFF (28h): Display Off

| 28H | DISPOFF (Display Off) | | | | | | | | | | | | | | | | | | | |
|-------------------|---|-----|-----|-------|----|----|--------|---------------|-------------------|-------------|-----------|-------------|-----------|-------------|--|--|--|--|--|--|
| Inst / Para | D/CX | WRX | RDX | D17-8 | D7 | D6 | D5 | D4 | D3 | D2 | D1 | D0 | HEX | | | | | | | |
| DISPOFF | 0 | ↑ | 1 | - | 0 | 0 | 1 | 0 | 1 | 0 | 0 | 0 | (28h) | | | | | | | |
| Parameter | No Parameter | | | | | | | | | | | | - | | | | | | | |
| Description | <p>- This command is used to enter into DISPLAY OFF mode. In this mode, the output from Frame Memory is disabled and blank page inserted.</p> <p>- This command makes no change of contents of frame memory.</p> <p>- This command does not change any other status.</p> <p>- There will be no abnormal visible effect on the display.</p> <p>- Exit from this command by Display On (29h)</p> <p style="text-align: center;">(Example)</p> <div style="display: flex; justify-content: space-around; align-items: center;"> <div style="text-align: center;"> <p>Memory</p>  </div> <div style="font-size: 2em;">→</div> <div style="text-align: center;"> <p>Display</p>  </div> </div> | | | | | | | | | | | | | | | | | | | |
| Default | <table border="1" style="width: 100%; text-align: center;"> <thead> <tr style="background-color: #ffffcc;"> <th>Status</th> <th>Default Value</th> </tr> </thead> <tbody> <tr> <td>Power On Sequence</td> <td>Display off</td> </tr> <tr> <td>S/W Reset</td> <td>Display off</td> </tr> <tr> <td>H/W Reset</td> <td>Display off</td> </tr> </tbody> </table> | | | | | | Status | Default Value | Power On Sequence | Display off | S/W Reset | Display off | H/W Reset | Display off | | | | | | |
| Status | Default Value | | | | | | | | | | | | | | | | | | | |
| Power On Sequence | Display off | | | | | | | | | | | | | | | | | | | |
| S/W Reset | Display off | | | | | | | | | | | | | | | | | | | |
| H/W Reset | Display off | | | | | | | | | | | | | | | | | | | |
| Flow Chart | <div style="display: flex; justify-content: space-between;"> <div style="flex: 1;">  <pre> graph TD A([Display On Mode]) --> B[/DISPOFF/] B --> C([Display Off Mode]) </pre> </div> <div style="flex: 1; border: 1px dashed black; padding: 5px;"> <p style="text-align: center;">Legend</p> <ul style="list-style-type: none">  Command  Parameter  Display  Action  Mode  Sequential transfer </div> </div> | | | | | | | | | | | | | | | | | | | |

10.1.19 DISPON (29h): Display On

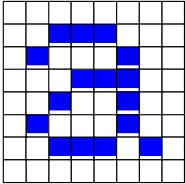
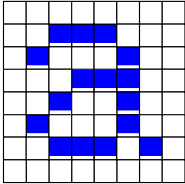
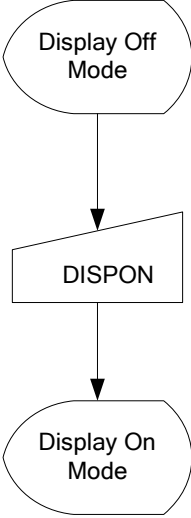
| 29H | DISPON (Display On) | | | | | | | | | | | | | | | | | | | |
|-------------------|--|-----|-----|-------|----|----|----|----|----|----|----|----|--------|---------------|-------------------|-------------|-----------|-------------|-----------|-------------|
| Inst / Para | D/CX | WRX | RDX | D17-8 | D7 | D6 | D5 | D4 | D3 | D2 | D1 | D0 | HEX | | | | | | | |
| DISPON | 0 | ↑ | 1 | - | 0 | 0 | 1 | 0 | 1 | 0 | 0 | 1 | (29h) | | | | | | | |
| Parameter | No Parameter | | | | | | | | | | | | - | | | | | | | |
| Description | <p>- This command is used to recover from DISPLAY OFF mode. - Output from the Frame Memory is enabled. - This command makes no change of contents of frame memory. - This command does not change any other status.</p> <p style="text-align: center;">(Example)</p> <div style="display: flex; justify-content: space-around; align-items: center;"> <div style="text-align: center;"> <p>Memory</p>  </div> <div style="font-size: 2em;">→</div> <div style="text-align: center;"> <p>Display</p>  </div> </div> | | | | | | | | | | | | | | | | | | | |
| Default | <table border="1" style="width: 100%; border-collapse: collapse;"> <thead> <tr> <th style="background-color: #ffffcc;">Status</th> <th style="background-color: #ffffcc;">Default Value</th> </tr> </thead> <tbody> <tr> <td>Power On Sequence</td> <td>Display off</td> </tr> <tr> <td>S/W Reset</td> <td>Display off</td> </tr> <tr> <td>H/W Reset</td> <td>Display off</td> </tr> </tbody> </table> | | | | | | | | | | | | Status | Default Value | Power On Sequence | Display off | S/W Reset | Display off | H/W Reset | Display off |
| Status | Default Value | | | | | | | | | | | | | | | | | | | |
| Power On Sequence | Display off | | | | | | | | | | | | | | | | | | | |
| S/W Reset | Display off | | | | | | | | | | | | | | | | | | | |
| H/W Reset | Display off | | | | | | | | | | | | | | | | | | | |
| Flow Chart | <div style="display: flex; align-items: center;"> <div style="flex: 1;">  <pre> graph TD A([Display Off Mode]) --> B[/DISPON/] B --> C([Display On Mode]) </pre> </div> <div style="flex: 1; border: 1px dashed black; padding: 5px;"> <p style="text-align: center; margin: 0;">Legend</p> <div style="display: flex; flex-direction: column; gap: 10px;"> <div style="border: 1px solid black; padding: 5px; width: 100px; height: 20px; margin: 0 auto;"></div> <p style="text-align: center; margin: 0;">Command</p> <div style="border: 1px solid black; padding: 5px; width: 100px; height: 40px; margin: 0 auto;"></div> <p style="text-align: center; margin: 0;">Parameter</p> <div style="border: 1px solid black; padding: 5px; width: 100px; height: 40px; margin: 0 auto;"></div> <p style="text-align: center; margin: 0;">Display</p> <div style="border: 1px solid black; padding: 5px; width: 100px; height: 40px; margin: 0 auto;"></div> <p style="text-align: center; margin: 0;">Action</p> <div style="border: 1px solid black; padding: 5px; width: 100px; height: 40px; margin: 0 auto;"></div> <p style="text-align: center; margin: 0;">Mode</p> <div style="border: 1px solid black; padding: 5px; width: 100px; height: 40px; margin: 0 auto;"></div> <p style="text-align: center; margin: 0;">Sequential transfer</p> </div> </div> </div> | | | | | | | | | | | | | | | | | | | |

10.1.20 CASET (2Ah): Column Address Set

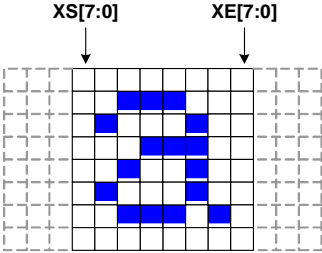
| 2AH | CASET(Column Address Set)_ | | | | | | | | | | | | |
|---------------------------|--|-----|-----|-------|------|------|------|------|------|------|-----|-----|-------|
| Inst / Para | D/CX | WRX | RDX | D17-8 | D7 | D6 | D5 | D4 | D3 | D2 | D1 | D0 | HEX |
| CASET(2Ah) | 0 | ↑ | 1 | - | 0 | 0 | 1 | 0 | 1 | 0 | 1 | 0 | (2Ah) |
| 1 st Parameter | 1 | ↑ | 1 | - | XS15 | XS14 | XS13 | XS12 | XS11 | XS10 | XS9 | XS8 | |
| 2 nd Parameter | 1 | ↑ | 1 | - | XS7 | XS6 | XS5 | XS4 | XS3 | XS2 | XS1 | XS0 | |
| 3 rd Parameter | 1 | ↑ | 1 | - | XE15 | XE14 | XE13 | XE12 | XE11 | XE10 | XE9 | XE8 | |
| 4 th Parameter | 1 | ↑ | 1 | - | XE7 | XE6 | XE5 | XE4 | XE3 | XE2 | XE1 | XE0 | |
| Description | <p>-The value of XS [7:0] and XE [7:0] are referred when RAMWR command comes. -Each value represents one column line in the Frame Memory.</p>  | | | | | | | | | | | | |
| Restriction | <p>XS [15:0] always must be equal to or less than XE [15:0] When XS [15:0] or XE [15:0] is greater than maximum address like below, data of out of range will be ignored.</p> <ol style="list-style-type: none"> 128X160 memory base (GM = '11') (Parameter range: 0 < XS [15:0] < XE [15:0] < 127 (007Fh)): MV="0" (Parameter range: 0 < XS [15:0] < XE [15:0] < 159 (009Fh)): MV="1" 132X132 memory base (GM = '01') (Parameter range: 0 < XS [15:0] < XE [15:0] < 131 (0083h)): MV="0" (Parameter range: 0 < XS [15:0] < XE [15:0] < 131 (0083h)): MV="1" 132X162 memory base (GM = '00') (Parameter range: 0 < XS [15:0] < XE [15:0] < 131 (0083h)): MV="0" (Parameter range: 0 < XS [15:0] < XE [15:0] < 161 (00A1h)): MV="1" | | | | | | | | | | | | |

| GM Status | Status | Default Value | | |
|-------------------------------------|-------------------|---------------|-------------------|-------------------|
| | | XS [7:0] | XE [7:0] (MV='0') | XE [7:0] (MV='1') |
| GM='11' (128x160 Memory Base) | Power On Sequence | 0000h | 007Fh (127) | |
| | S/W Reset | 0000h | 007Fh (127) | 009Fh (159) |
| | H/W Reset | 0000h | 007Fh (127) | |
| GM='01' (132x132 Memory Base) | Power On Sequence | 0000h | 0083h (131) | |
| | S/W Reset | 0000h | 0083h (131) | 0083h (131) |
| | H/W Reset | 0000h | 0083h (131) | |
| GM='00' (132x162 Memory Base) | Power On Sequence | 0000h | 0083h (131) | |
| | S/W Reset | 0000h | 0083h (131) | 00A1h (161) |
| | H/W Reset | 0000h | 0083h (131) | |

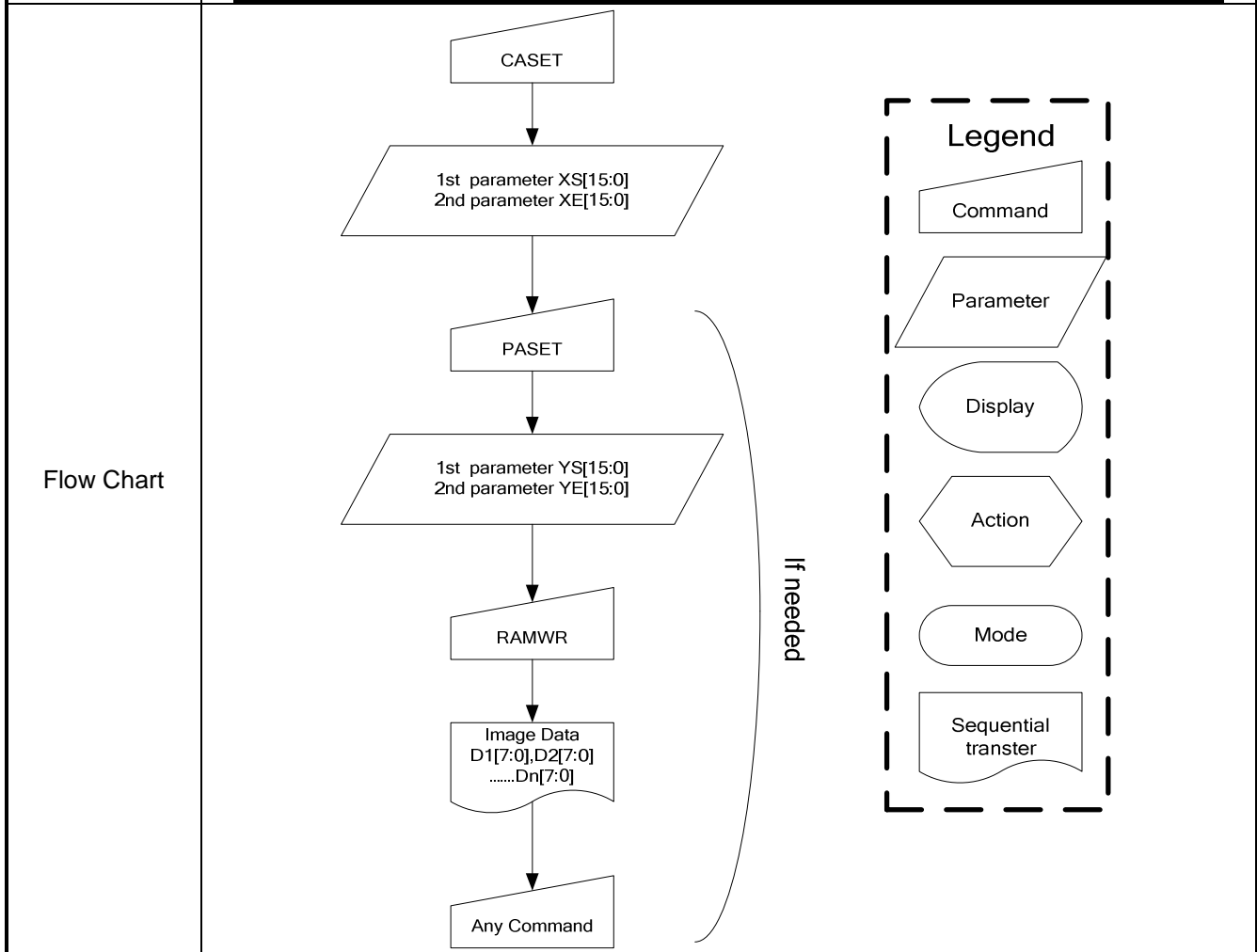

10.1.21 RASET (2Bh): Row Address Set

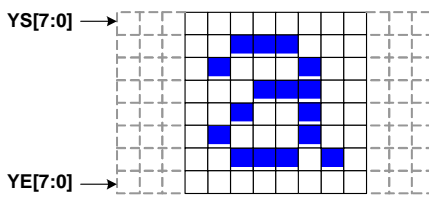
| 2BH | RASET (Row Address Set) | | | | | | | | | | | | HEX |
|---------------------------|---|-----|-----|-------|------|------|------|------|------|------|-----|-----|-------|
| Inst / Para | D/CX | WRX | RDX | D17-8 | D7 | D6 | D5 | D4 | D3 | D2 | D1 | D0 | HEX |
| RASET (2Bh) | 0 | ↑ | 1 | - | 0 | 0 | 1 | 0 | 1 | 0 | 1 | 1 | (2Bh) |
| 1 st Parameter | 1 | ↑ | 1 | - | YS15 | YS14 | YS13 | YS12 | YS11 | YS10 | YS9 | YS8 | |
| 2 nd Parameter | 1 | ↑ | 1 | - | YS7 | YS6 | YS5 | YS4 | YS3 | YS2 | YS1 | YS0 | |
| 3 rd Parameter | 1 | ↑ | 1 | - | YE15 | YE14 | YE13 | YE12 | YE11 | YE10 | YE9 | YE8 | |
| 4 th Parameter | 1 | ↑ | 1 | - | YE7 | YE6 | YE5 | YE4 | YE3 | YE2 | YE1 | YE0 | |
| Description | <p>The value of YS [7:0] and YE [7:0] are referred when RAMWR command comes. Each value represents one column line in the Frame Memory.</p>  | | | | | | | | | | | | |
| Restriction | <p>YS [15:0] always must be equal to or less than YE [15:0] When YS [15:0] or YE [15:0] are greater than maximum row address like below, data of out of range will be ignored.</p> <ol style="list-style-type: none"> 128X160 memory base (GM = '11') (Parameter range: 0 < YS [15:0] < YE [15:0] < 159 (009Fh)): MV="0" (Parameter range: 0 < YS [15:0] < YE [15:0] < 127 (007Fh)): MV="1" 132X132 memory base (GM = '00') (Parameter range: 0 < YS [15:0] < YE [15:0] < 131 (00A1h)): MV="0" (Parameter range: 0 < YS [15:0] < YE [15:0] < 131 (0083h)): MV="1" 132X162 memory base (GM = '00') (Parameter range: 0 < YS [15:0] < YE [15:0] < 161 (00A1h)): MV="0" (Parameter range: 0 < YS [15:0] < YE [15:0] < 131 (0083h)): MV="1" | | | | | | | | | | | | |

| | GM status | Status | Default Value | | |
|---------|-------------------------------------|----------------------|---------------|-----------------------|-----------------------|
| | | | YS [15:0] | YE [15:0] (MV='0') | YE [15:0] (MV='1') |
| Default | GM='11' (128x160 memory base) | Power On Sequence | 0000h | 009Fh (159) | |
| | | S/W Reset | 0000h | 009Fh (159) | 007Fh (127) |
| | | H/W Reset | 0000h | 009Fh (159) | |
| | GM='01' (132x132 Memory Base) | Power On Sequence | 0000h | 0083h (131) | |
| | | S/W Reset | 0000h | 0083h (131) | 0083h (131) |
| | | H/W Reset | 0000h | 0083h (131) | |
| | GM='00' (132x162 memory base) | Power On Sequence | 0000h | 00A1h (161) | |
| | | S/W Reset | 0000h | 00A1h (161) | 0083h (131) |
| | | H/W Reset | 0000h | 00A1h (161) | |

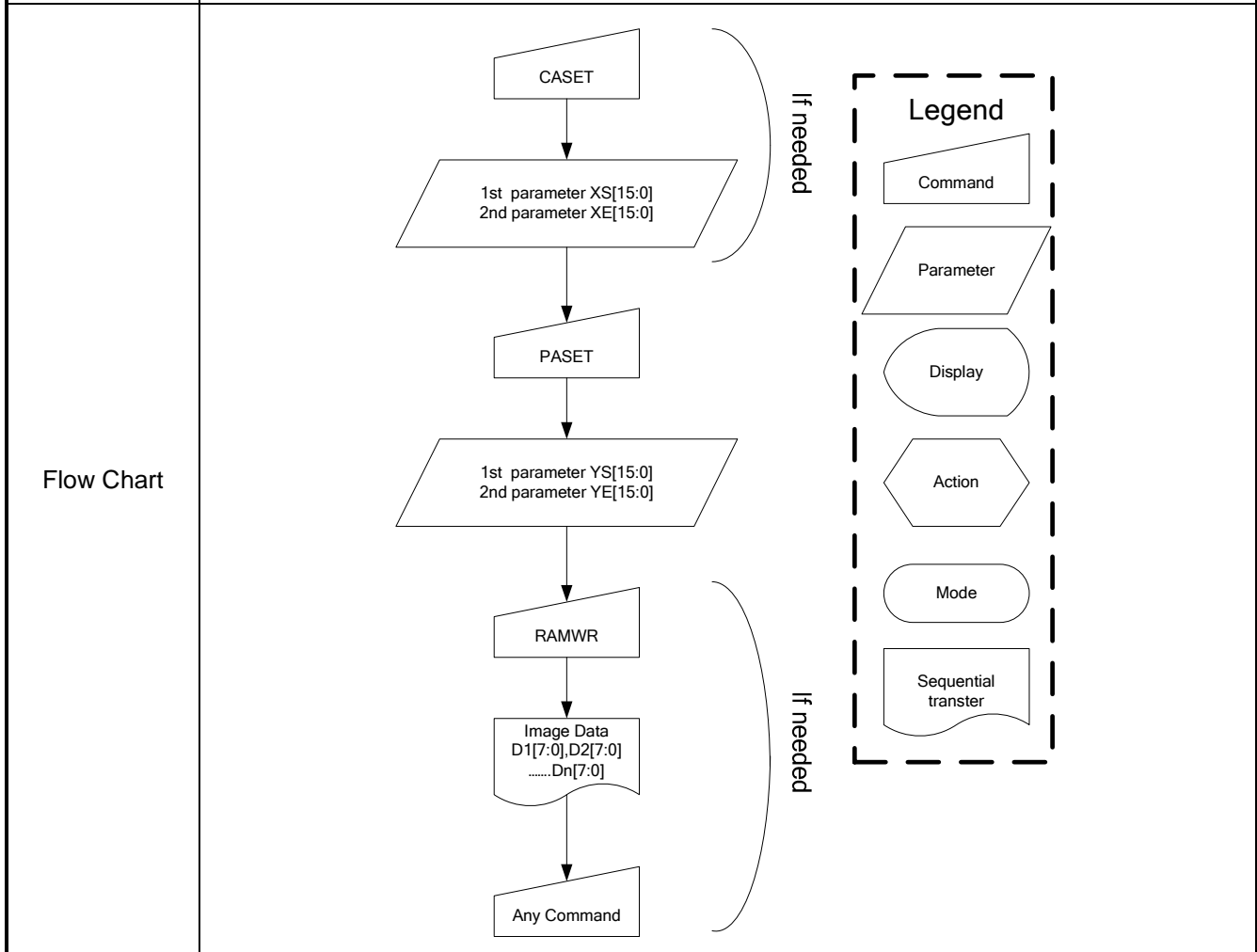

10.1.22 RAMWR (2Ch): Memory Write

| 2CH | RAMWR (Memory Write) | | | | | | | | | | | | | | | | | | | | |
|-------------------|---|-----|-----|-------|----|----|----|----|----|----|----|----|-------|--------|---------------|-------------------|------------------------------------|-----------|-----------------------------------|-----------|-----------------------------------|
| Inst / Para | D/CX | WRX | RDX | D17-8 | D7 | D6 | D5 | D4 | D3 | D2 | D1 | D0 | HEX | | | | | | | | |
| RAMWR | 0 | ↑ | 1 | - | 0 | 0 | 1 | 0 | 1 | 1 | 0 | 0 | (2Ch) | | | | | | | | |
| 1st Parameter | 1 | ↑ | 1 | D17-8 | D7 | D6 | D5 | D4 | D3 | D2 | D1 | D0 | | | | | | | | | |
| | 1 | ↑ | 1 | | | | | | | | | | | | | | | | | | |
| Nth Parameter | 1 | ↑ | 1 | D17-8 | D7 | D6 | D5 | D4 | D3 | D2 | D1 | D0 | | | | | | | | | |
| Description | <p>In all color modes, there is no restriction on length of parameters.</p> <p>1. 128X160 memory base (GM = '11') 128x160x18-bit memory can be written by this command Memory range: (0000h, 0000h) -> (007Fh, 09Fh)</p> <p>2. 132x132 memory base (GM = '01') 132x132x18-bit memory can be written on this command. Memory range: (0000h, 0000h) -> (0083h, 0083h)</p> <p>3. 132x162 memory base (GM = '00') 132x162x18-bit memory can be written on this command. Memory range: (0000h, 0000h) -> (0083h, 00A1h)</p> | | | | | | | | | | | | | | | | | | | | |
| Default | <table border="1"> <thead> <tr> <th>Status</th> <th>Default Value</th> </tr> </thead> <tbody> <tr> <td>Power On Sequence</td> <td>Contents of memory is set randomly</td> </tr> <tr> <td>S/W Reset</td> <td>Contents of memory is not cleared</td> </tr> <tr> <td>H/W Reset</td> <td>Contents of memory is not cleared</td> </tr> </tbody> </table> | | | | | | | | | | | | | Status | Default Value | Power On Sequence | Contents of memory is set randomly | S/W Reset | Contents of memory is not cleared | H/W Reset | Contents of memory is not cleared |
| Status | Default Value | | | | | | | | | | | | | | | | | | | | |
| Power On Sequence | Contents of memory is set randomly | | | | | | | | | | | | | | | | | | | | |
| S/W Reset | Contents of memory is not cleared | | | | | | | | | | | | | | | | | | | | |
| H/W Reset | Contents of memory is not cleared | | | | | | | | | | | | | | | | | | | | |
| Flow Chart | <pre> graph TD A[RAMWR] --> B[Image Data D1[7:0], D2[7:0] Dn[7:0]] B --> C[Any Command] </pre> <p>Legend</p> <ul style="list-style-type: none"> Command: Trapezoid Parameter: Parallelogram Display: Oval Action: Hexagon Mode: Rounded rectangle Sequential transfer: Wavy-bottom rectangle | | | | | | | | | | | | | | | | | | | | |

10.1.23 RGBSET (2Dh): Color Setting for 4K, 65K and 262K

| 2DH | RGBSET (Color Set for 4K, 65K, 262K and 16.7M) | | | | | | | | | | | | |
|-----------------|---|-----|-----|-------|----|----|---|------|------|------|------|------|-------|
| Inst / Para | D/CX | WRX | RDX | D17-8 | D7 | D6 | D5 | D4 | D3 | D2 | D1 | D0 | HEX |
| RGBSET | 0 | ↑ | 1 | - | 0 | 0 | 1 | 0 | 1 | 1 | 0 | 1 | (2Dh) |
| 1st Parameter | 1 | ↑ | 1 | - | - | - | R005 | R004 | R003 | R002 | R001 | R000 | |
| | 1 | ↑ | 1 | - | - | - | Rnn5 | Rnn4 | Rnn3 | Rnn2 | Rnn1 | Rnn0 | |
| | 1 | ↑ | 1 | - | - | - | R315 | R314 | R313 | R312 | R311 | R310 | |
| | 1 | ↑ | 1 | - | - | - | G005 | G004 | G003 | G002 | G001 | G000 | |
| | 1 | ↑ | 1 | - | - | - | Gnn5 | Gnn4 | Gnn3 | Gnn2 | Gnn1 | Gnn0 | |
| | 1 | ↑ | 1 | - | - | - | G635 | G634 | G633 | G632 | G631 | G630 | |
| | 1 | ↑ | 1 | - | - | - | B005 | B004 | B003 | B002 | B001 | B000 | |
| | 1 | ↑ | 1 | - | - | - | Bnn5 | Bnn4 | Bnn3 | Bnn2 | Bnn1 | Bnn0 | |
| 128th Parameter | 1 | ↑ | 1 | - | - | - | B315 | B314 | B313 | B312 | B311 | B310 | |
| Description | <p>This command is used to define the LUT for 12bits-to-16bits / 16-bit-to- 18bits color depth conversations. 128-Bytes must be written to the LUT regardless of the color mode. Only the values in Section 9.18 are referred. In this condition, 4K-color (4-4-4) and 65K-color(5-6-5) data input are transferred 6(R)-6(G)-6(B) through RGB LUT table. This command has no effect on other commands/parameters and Contents of frame memory. Visible change takes effect next time the Frame Memory is written to. Do not send any command before the last data is sent or LUT is not defined correctly.</p> | | | | | | | | | | | | |
| Default | Status | | | | | | Default Value | | | | | | |
| | Power On Sequence | | | | | | Random | | | | | | |
| | S/W Reset | | | | | | Contents of the look-up table protected | | | | | | |
| | | | | | | | | | | | | | |
| Flow Chart | <pre> graph TD A[RGBSET (2Dh)] --> B[1st parameter: 128th parameter:] </pre> | | | | | | | | | | | | |

10.1.24 RAMRD (2Eh): Memory Read

| 2EH | RAMHD (Memory Read) | | | | | | | | | | | | |
|---------------------------|---|-----|-----|-------|----|----|------------------------------------|----|----|----|----|----|-------|
| Inst / Para | D/CX | WRX | RDX | D17-8 | D7 | D6 | D5 | D4 | D3 | D2 | D1 | D0 | HEX |
| RAMHD | 0 | ↑ | 1 | - | 0 | 0 | 1 | 0 | 1 | 1 | 1 | 0 | (2Eh) |
| 1 st Parameter | 1 | 1 | ↑ | - | - | - | - | - | - | - | - | - | |
| 2 nd Parameter | 1 | 1 | ↑ | D17-8 | D7 | D6 | D5 | D4 | D3 | D2 | D1 | D0 | |
| | 1 | 1 | ↑ | | | | | | | | | | |
| (N+1)th Parameter | 1 | 1 | ↑ | D17-8 | D7 | D6 | D5 | D4 | D3 | D2 | D1 | D0 | |
| Description | <p>-This command is used to transfer data from frame memory to MCU. -When this command is accepted, the column register and the row register are reset to the Start Column/Start Row positions. -The Start Column/Start Row positions are different in accordance with MADCTL setting. -Then D[17:0] is read back from the frame memory and the column register and the row register incremented as section 9.10 -Frame Read can be cancelled by sending any other command. -The data color coding is fixed to 18-bit in reading function. Please see section 9.8 "Data color coding" for color coding (18-bit cases), when there is used 8, 9, 16 and 18-bit data lines for image data.</p> <p>Note1: The Command 3Ah should be set to 66h when reading pixel data from frame memory. Please check the LUT in chapter 9.17 when using memory read function.</p> | | | | | | | | | | | | |
| Default | Status | | | | | | Default Value | | | | | | |
| | Power On Sequence | | | | | | Contents of memory is set randomly | | | | | | |
| | S/W Reset | | | | | | Contents of memory is not cleared | | | | | | |
| | H/W Reset | | | | | | Contents of memory is not cleared | | | | | | |
| Flow Chart | <pre> graph TD RAMRD[RAMRD] --> Dummy[/Dummy/] Dummy --> ImageData[Image Data D1[7:0], D2[7:0]Dn[7:0]] ImageData --> AnyCommand[Any Command] </pre> <p>Legend</p> <ul style="list-style-type: none"> Command: Rectangle Parameter: Parallelogram Display: Oval Action: Hexagon Mode: Rounded rectangle Sequential transfer: Wavy rectangle | | | | | | | | | | | | |

10.1.25 PTLAR (30h): Partial Area

| 30H | PTLAR (Partial Area) | | | | | | | | | | | | |
|---------------|----------------------|-----|-----|-------|-------|-------|-------|-------|-------|-------|------|------|-------|
| Inst / Para | D/CX | WRX | RDX | D17-8 | D7 | D6 | D5 | D4 | D3 | D2 | D1 | D0 | HEX |
| PTLAR | 0 | ↑ | 1 | - | 0 | 0 | 1 | 1 | 0 | 0 | 0 | 0 | (30h) |
| 1st Parameter | 1 | ↑ | 1 | - | PSL15 | PSL14 | PSL13 | PSL12 | PSL11 | PSL10 | PSL9 | PSL8 | |
| 2nd Parameter | 1 | ↑ | 1 | - | PSL7 | PSL6 | PSL5 | PSL4 | PSL3 | PSL2 | PSL1 | PSL0 | |
| 3rd Parameter | 1 | ↑ | 1 | - | PEL15 | PEL14 | PEL13 | PEL12 | PEL11 | PEL10 | PEL9 | PEL8 | |
| 4th Parameter | 1 | ↑ | 1 | - | PEL7 | PEL6 | PEL5 | PEL4 | PEL3 | PEL2 | PEL1 | PEL0 | |

Description

- This command defines the partial mode's display area.
- There are 4 parameters associated with this command, the first defines the Start Row (PSL) and the second the End Row (PEL), as illustrated in the figures below. PSL and PEL refer to the Frame Memory row address counter.
- If End Row > Start Row, when MADCTL ML='0'

- If End Row > Start Row, when MADCTL ML='1'

- If End Row < Start Row, when MADCTL ML='0'

- If End Row = Start Row then the Partial Area will be one row deep.

| | | | | | |
|---------|-------------------|------------|---------------|--------------|--------------|
| Default | Status | | Default Value | | |
| | | PSL [15:0] | PEL [15:0] | | |
| | GM[1:0] | "xx" | GM[1:0]="11" | GM[1:0]="01" | GM[1:0]="00" |
| | Power On Sequence | 0000h | 009Fh | 0083h | 00A1h |
| | S/W Reset | 0000h | 009Fh | 0083h | 00A1h |
| | H/W Reset | 0000h | 009Fh | 0083h | 00A1h |

1. To Enter Partial Mode:

```

graph TD
    PLTAR[PLTAR] --> SR[SR[15:0]]
    SR --> ER[ER[15:0]]
    ER --> PTLON[PTLON]
    PTLON --> PM[Partial Mode]
            
```

2. Leave Partial Mode

```

graph TD
    PM([Partial Mode]) --> DISPOFF[/DISPOFF/]
    DISPOFF --> NORON[/NORON/]
    NORON --> PMOFF([Partial Mode OFF])
    PMOFF --> RAMRW[/RAMRW/]
    RAMRW --> ID[Image Data  
D1[7:0], D2[7:0]  
.....Dn[7:0]]
    ID --> DISPON[/DISPON/]
            
```

(optional)
To prevent
Tearing Effect
Image displayed

Legend

- ▭ Command
- ▱ Parameter
- Display
- ⬡ Action
- ⭕ Mode
- ⌋ Sequential transfer

10.1.26 SCRLAR (33h): Scroll Area Set

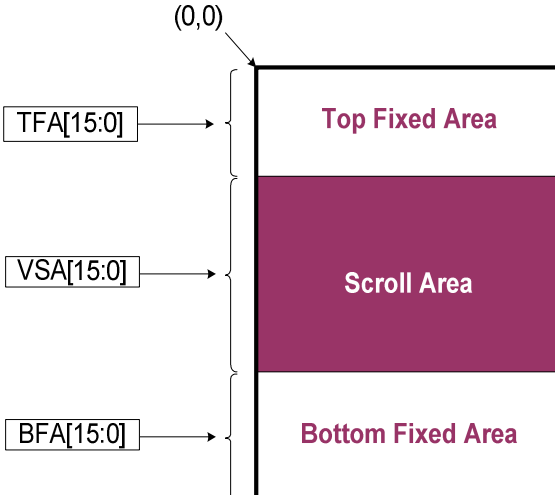
| 33H | SCRLAR (Scroll Area) | | | | | | | | | | | | HEX | | | | | | | | | | | |
|---|--|-----|-----|-------|-------|-------|-------|-------|-------|-------|------|------|--------|--------------|--|-----|---|-----|---|-----|--|-----|----------|-----|
| Inst / Para | D/CX | WRX | RDX | D17-8 | D7 | D6 | D5 | D4 | D3 | D2 | D1 | D0 | HEX | | | | | | | | | | | |
| SCRLAR | 0 | ↑ | 1 | - | 0 | 0 | 1 | 1 | 0 | 0 | 1 | 1 | (33h) | | | | | | | | | | | |
| 1 st parameter | 1 | ↑ | 1 | - | TFA15 | TFA14 | TFA13 | TFA12 | TFA11 | TFA10 | TFA9 | TFA8 | - | | | | | | | | | | | |
| 2 nd parameter | 1 | ↑ | 1 | - | TFA7 | TFA6 | TFA5 | TFA4 | TFA3 | TFA2 | TFA1 | TFA0 | - | | | | | | | | | | | |
| 3 rd parameter | 1 | ↑ | 1 | - | VSA15 | VSA14 | VSA13 | VSA12 | VSA11 | VSA10 | VSA9 | VSA8 | - | | | | | | | | | | | |
| 4 th parameter | 1 | ↑ | 1 | - | VSA7 | VSA6 | VSA5 | VSA4 | VSA3 | VSA2 | VSA1 | VSA0 | - | | | | | | | | | | | |
| 5 th parameter | 1 | ↑ | 1 | - | BFA15 | BFA14 | BFA13 | BFA12 | BFA11 | BFA10 | BFA9 | BFA8 | - | | | | | | | | | | | |
| 6 nd parameter | 1 | ↑ | 1 | - | BFA7 | BFA6 | BFA5 | BFA4 | BFA3 | BFA2 | BFA1 | BFA0 | - | | | | | | | | | | | |
| Description | <p>-This command just defines the Vertical Scrolling Area of the display and not performs vertical scroll</p> <p>-When MADCTR B4=0</p> <p>-The 1st & 2nd parameter TFA [15:0] describes the Top Fixed Area (in No. of lines from Top of the Frame Memory and Display).</p> <p>-The 3rd & 4th parameter VSA [15:0] describes the height of the Vertical Scrolling Area (in No. of lines of the Frame Memory [not the display] from the Vertical Scrolling Start Address) The first line appears immediately after the bottom most line of the Top Fixed Area.</p> <p>-The 4th & 5th parameter BFA [6:0] describes the Bottom Fixed Area (in No. of lines from Bottom of the Frame Memory and Display).</p> <p>TFA, VSA and BFA refer to the Frame Memory Line Pointer</p>  | | | | | | | | | | | | | | | | | | | | | | | |
| Restriction | <p>The condition is $(TFA+VSA+BFA) = 162$, otherwise Scrolling mode is undefined.</p> <p>In Vertical Scroll Mode, MADCTR parameter MV should be set to '0'-this only affects the Frame Memory Write.</p> <p>TFA[15:0], VSA[15:0] and BFA[15:0] is based on line unit.</p> <p>TFA[15:0]= 0000h, 0001h, 0002h, 0003h, ... , 00A2h</p> <p>VSA[15:0]= 0000h, 0001h, 0002h, 0003h, ... , 00A2h</p> <p>BFA[15:0]= 0000h, 0001h, 0002h, 0003h, ... , 00A2h</p> | | | | | | | | | | | | | | | | | | | | | | | |
| Register Availability | <table border="1"> <thead> <tr> <th>Status</th> <th>Availability</th> </tr> </thead> <tbody> <tr> <td>Normal Mode On, Idle Mode Off, Sleep Out</td> <td>Yes</td> </tr> <tr> <td>Normal Mode On, Idle Mode On, Sleep Out</td> <td>Yes</td> </tr> <tr> <td>Partial Mode On, Idle Mode Off, Sleep Out</td> <td>Yes</td> </tr> <tr> <td>Partial Mode On, Idle Mode On, Sleep Out</td> <td>Yes</td> </tr> <tr> <td>Sleep In</td> <td>Yes</td> </tr> </tbody> </table> | | | | | | | | | | | | Status | Availability | Normal Mode On, Idle Mode Off, Sleep Out | Yes | Normal Mode On, Idle Mode On, Sleep Out | Yes | Partial Mode On, Idle Mode Off, Sleep Out | Yes | Partial Mode On, Idle Mode On, Sleep Out | Yes | Sleep In | Yes |
| Status | Availability | | | | | | | | | | | | | | | | | | | | | | | |
| Normal Mode On, Idle Mode Off, Sleep Out | Yes | | | | | | | | | | | | | | | | | | | | | | | |
| Normal Mode On, Idle Mode On, Sleep Out | Yes | | | | | | | | | | | | | | | | | | | | | | | |
| Partial Mode On, Idle Mode Off, Sleep Out | Yes | | | | | | | | | | | | | | | | | | | | | | | |
| Partial Mode On, Idle Mode On, Sleep Out | Yes | | | | | | | | | | | | | | | | | | | | | | | |
| Sleep In | Yes | | | | | | | | | | | | | | | | | | | | | | | |

| Default | Status | Default Value GM[1:0]= "11" | | |
|-----------|-------------------|-----------------------------|-----------------|-----------------|
| | Power On Sequence | TFA[15:0]=0000h | VSA[15:0]=00A0h | BFA[15:0]=0000h |
| | S/W Reset | TFA[15:0]=0000h | VSA[15:0]=00A0h | BFA[15:0]=0000h |
| | H/W Reset | TFA[15:0]=0000h | VSA[15:0]=00A0h | BFA[15:0]=0000h |
| | Status | Default Value GM[1:0]= "01" | | |
| | Power On Sequence | TFA[15:0]=0000h | VSA[15:0]=0084h | BFA[15:0]=0000h |
| | S/W Reset | TFA[15:0]=0000h | VSA[15:0]=0084h | BFA[15:0]=0000h |
| | H/W Reset | TFA[15:0]=0000h | VSA[15:0]=0084h | BFA[15:0]=0000h |
| | Status | Default Value GM[1:0]= "00" | | |
| | Power On Sequence | TFA[15:0]=0000h | VSA[15:0]=00A2h | BFA[15:0]=0000h |
| S/W Reset | TFA[15:0]=0000h | VSA[15:0]=00A2h | BFA[15:0]=0000h | |
| H/W Reset | TFA[15:0]=0000h | VSA[15:0]=00A2h | BFA[15:0]=0000h | |

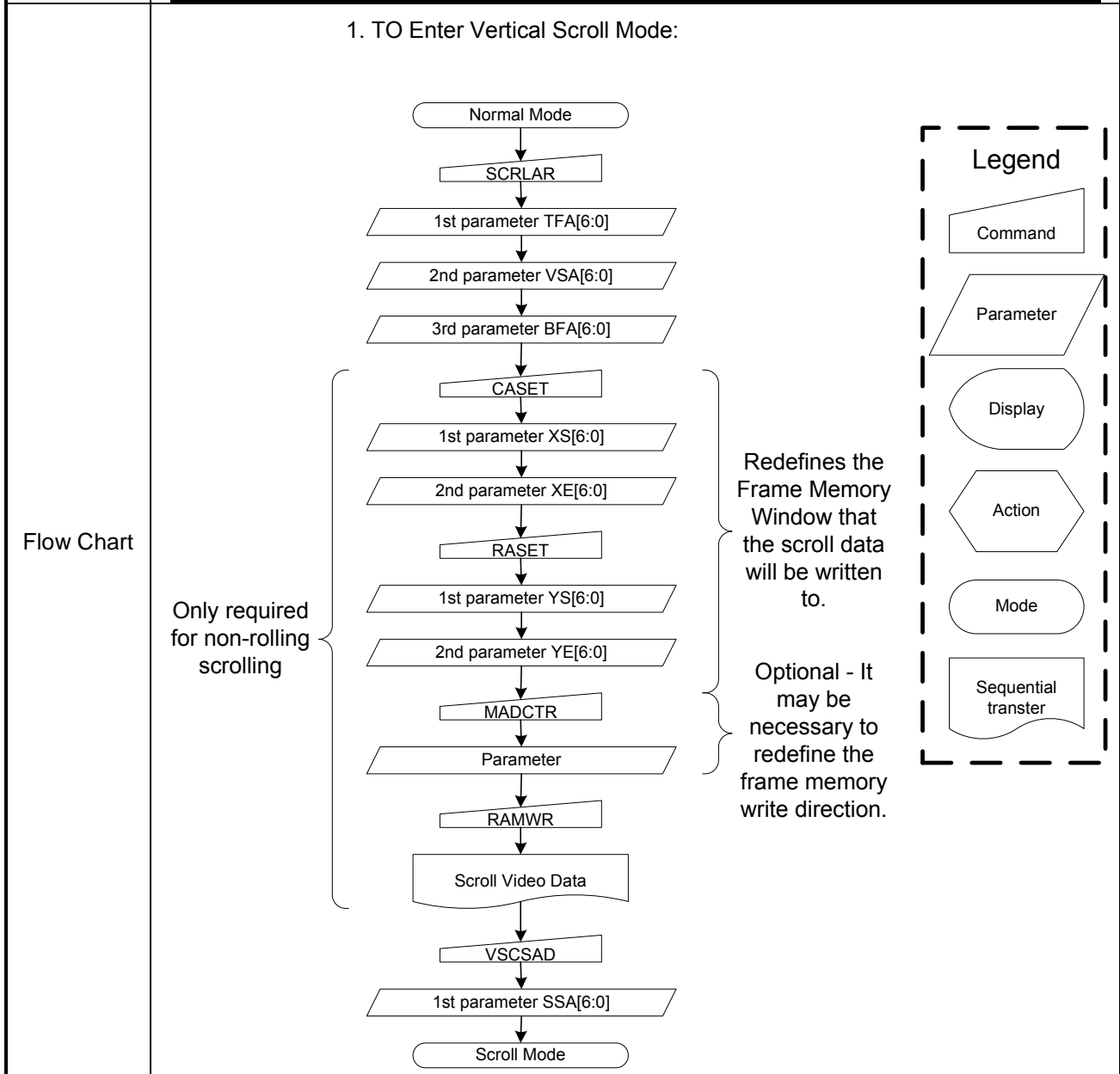

10.1.27 TEOFF (34h): Tearing Effect Line OFF

| 34H | TEOFF (Tearing Effect Line OFF) | | | | | | | | | | | | |
|-------------|--|-----|-----|-------|----|----|---------------|----|----|----|----|----|-------|
| Inst / Para | D/CX | WRX | RDX | D17-8 | D7 | D6 | D5 | D4 | D3 | D2 | D1 | D0 | HEX |
| TEOFF | 0 | ↑ | 1 | - | 0 | 0 | 1 | 1 | 0 | 1 | 0 | 0 | (34h) |
| Parameter | No Parameter | | | | | | | | | | | | - |
| Description | -This command is used to turn OFF (Active Low) the Tearing Effect output signal from the TE signal line. | | | | | | | | | | | | |
| Default | Status | | | | | | Default Value | | | | | | |
| | Power On Sequence | | | | | | OFF | | | | | | |
| | S/W Reset | | | | | | OFF | | | | | | |
| | H/W Reset | | | | | | OFF | | | | | | |
| Flow Chart | <pre> graph TD A([TE Line Output ON]) --> B[/TEOFF/] B --> C([TE Line Output OFF]) </pre> <p>Legend</p> <ul style="list-style-type: none"> Command: Trapezoid Parameter: Parallelogram Display: Oval Action: Hexagon Mode: Rounded rectangle Sequential transfer: Wavy bottom | | | | | | | | | | | | |

10.1.28 TEON (35h): Tearing Effect Line ON

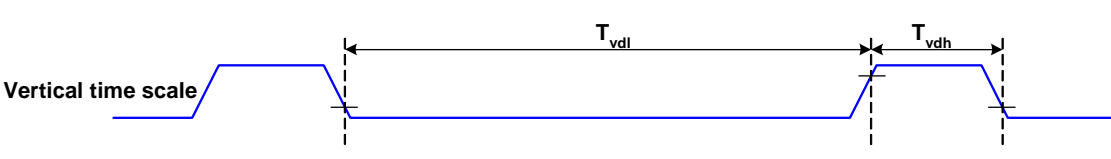
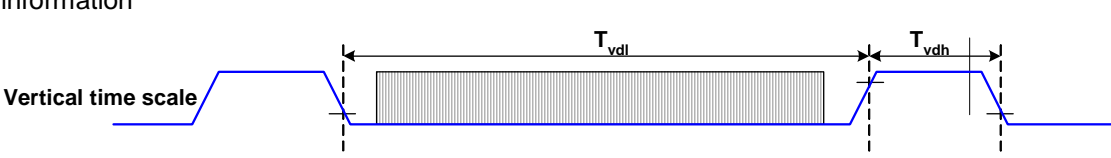
| 35H | TEON (Tearing Effect Line ON) | | | | | | | | | | | | | | | | | | | |
|-------------------|---|---|-----|-------|----|----|----|--------|---------------|-------------------|----------------------------|-----------|----------------------------|-----------|----------------------------|--|--|--|--|--|
| Inst / Para | D/CX | WRX | RDX | D17-8 | D7 | D6 | D5 | D4 | D3 | D2 | D1 | D0 | HEX | | | | | | | |
| TEON | 0 | ↑ | 1 | - | 0 | 0 | 1 | 1 | 0 | 1 | 0 | 1 | (35h) | | | | | | | |
| Parameter | 1 | ↑ | 1 | - | 0 | 0 | 0 | 0 | 0 | 0 | 0 | TEM | | | | | | | | |
| Description | <p>-This command is used to turn ON the Tearing Effect output signal from the TE signal line. -This output is not affected by changing MADCTL bit ML. -The Tearing Effect Line On has one parameter, which describes the mode of the Tearing Effect Output Line:</p> <p>-When TEM = '0': The Tearing Effect output line consists of V-Blanking information only</p>  <p>Vertical time scale</p> <p>-When TEM = '1': The Tearing Effect output Line consists of both V-Blanking and H-Blanking information</p>  <p>Vertical time scale</p> <p>Note: During Sleep In Mode with Tearing Effect Line On, Tearing Effect Output pin will be active Low.</p> | | | | | | | | | | | | | | | | | | | |
| | Default | <table border="1"> <thead> <tr> <th>Status</th> <th>Default Value</th> </tr> </thead> <tbody> <tr> <td>Power On Sequence</td> <td>Tearing effect off & TEM=0</td> </tr> <tr> <td>S/W Reset</td> <td>Tearing effect off & TEM=0</td> </tr> <tr> <td>H/W Reset</td> <td>Tearing effect off & TEM=0</td> </tr> </tbody> </table> | | | | | | Status | Default Value | Power On Sequence | Tearing effect off & TEM=0 | S/W Reset | Tearing effect off & TEM=0 | H/W Reset | Tearing effect off & TEM=0 | | | | | |
| Status | Default Value | | | | | | | | | | | | | | | | | | | |
| Power On Sequence | Tearing effect off & TEM=0 | | | | | | | | | | | | | | | | | | | |
| S/W Reset | Tearing effect off & TEM=0 | | | | | | | | | | | | | | | | | | | |
| H/W Reset | Tearing effect off & TEM=0 | | | | | | | | | | | | | | | | | | | |

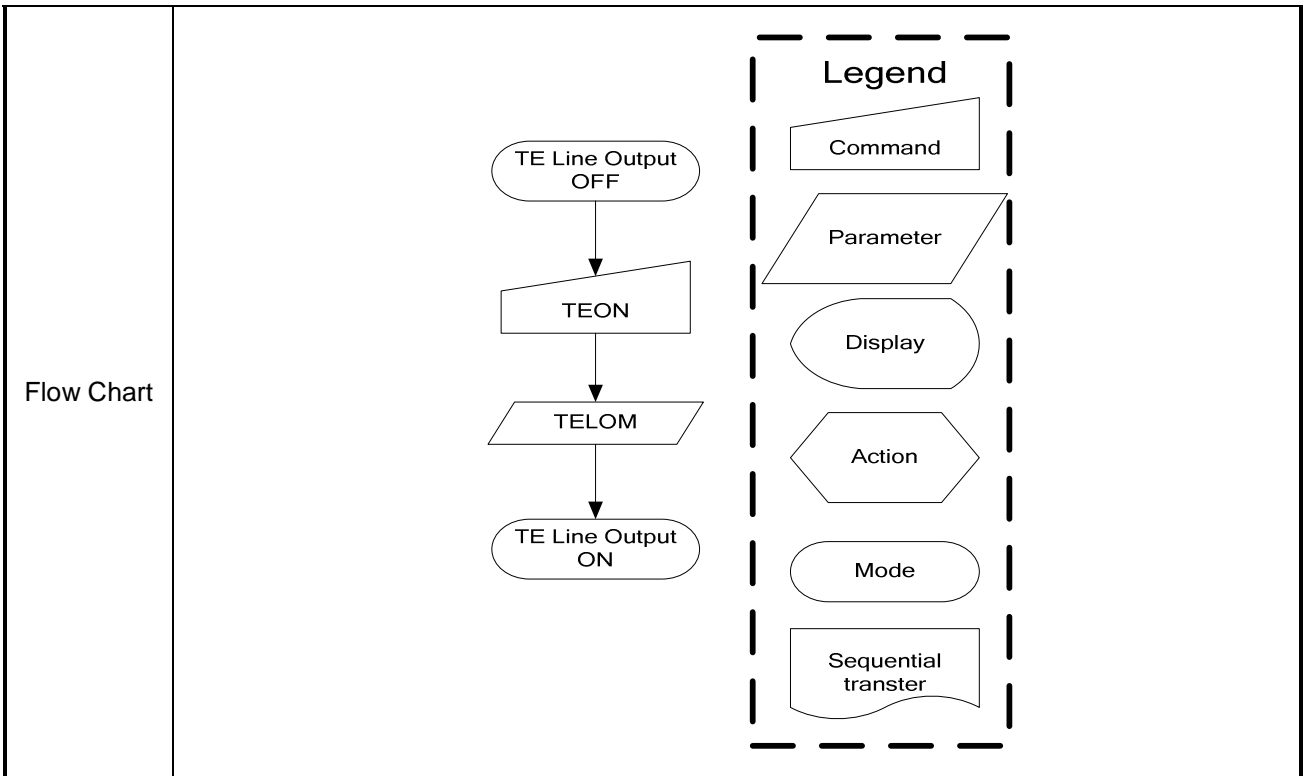

10.1.29 MADCTL (36h): Memory Data Access Control

| 36H | MADCTL (Memory Data Access Control) | | | | | | | | | | | | |
|-------------|-------------------------------------|-----|-----|-------|----|----|----|----|-----|----|----|----|-------|
| Inst / Para | D/CX | WRX | RDX | D17-8 | D7 | D6 | D5 | D4 | D3 | D2 | D1 | D0 | HEX |
| MADCTL | 0 | ↑ | 1 | - | 0 | 0 | 1 | 1 | 0 | 1 | 1 | 0 | (36h) |
| Parameter | 1 | ↑ | 1 | - | MY | MX | MV | ML | RGB | MH | - | - | |

-This command defines read/ write scanning direction of frame memory.

| Bit | NAME | DESCRIPTION |
|-----|--------------------------|--|
| MY | Row Address Order | These 3bits controls MCU to memory write/read direction. |
| MX | Column Address Order | |
| MV | Row/Column Exchange | |
| ML | Vertical Refresh Order | LCD vertical refresh direction control '0' = LCD vertical refresh Top to Bottom '1' = LCD vertical refresh Bottom to Top |
| RGB | RGB-BGR ORDER | Color selector switch control '0' =RGB color filter panel, '1' =BGR color filter panel) |
| MH | Horizontal Refresh Order | LCD horizontal refresh direction control '0' = LCD horizontal refresh Left to right '1' = LCD horizontal refresh right to left |

Description

-Bit Assignment

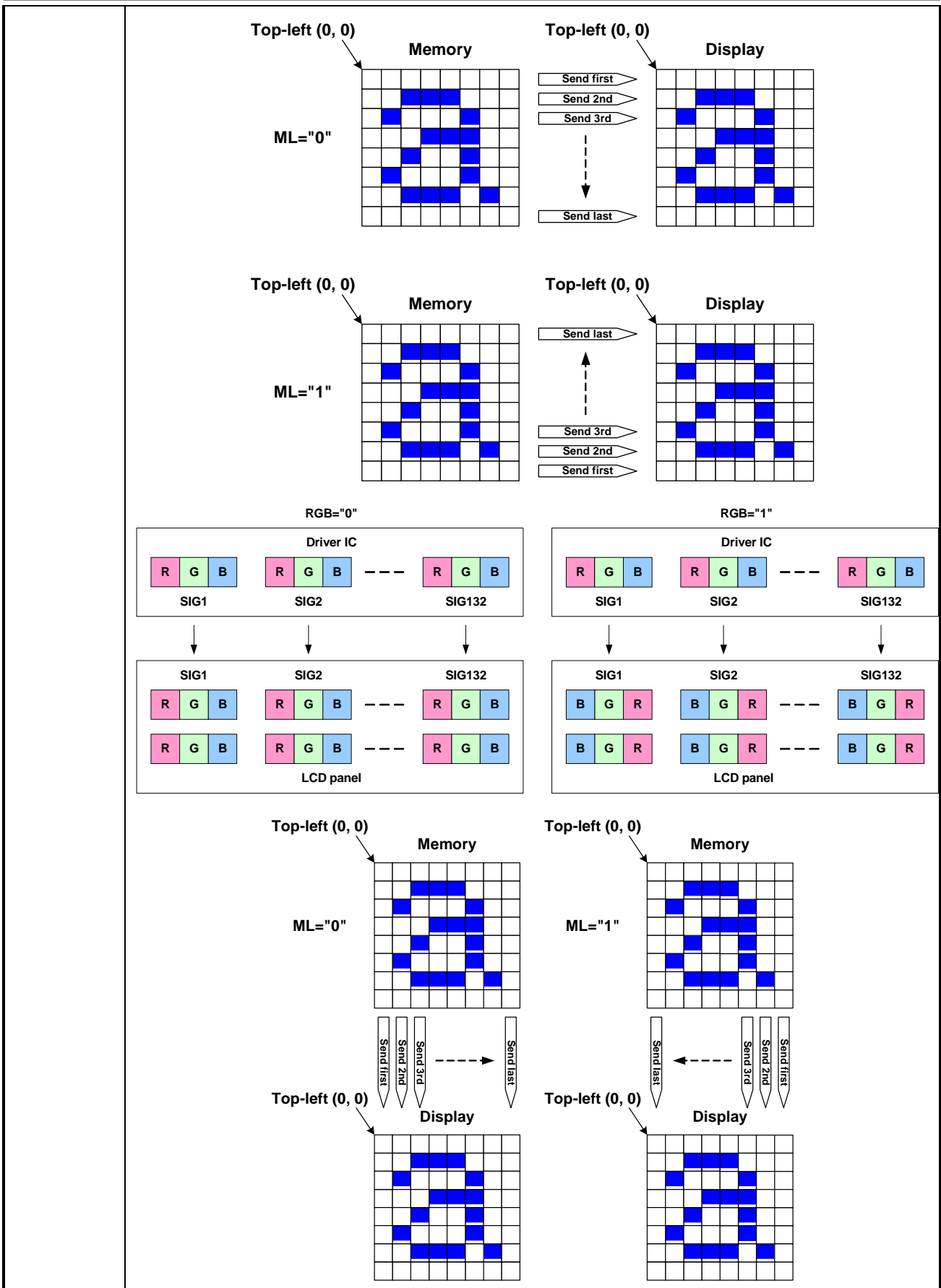

| | | |
|------------|---|--------------------------------|
| Default | Status | Default Value |
| | Power On Sequence | MY=0,MX=0,MV=0,ML=0,RGB=0,MH=0 |
| | S/W Reset | No Change |
| | H/W Reset | MY=0,MX=0,MV=0,ML=0,RGB=0,MH=0 |
| Flow Chart | <p>The flow chart shows a trapezoidal shape labeled 'MADCTL' with a downward arrow pointing to a parallelogram labeled '1st parameter B[7:0]'. To the right is a legend box containing six symbols: a trapezoid for 'Command', a parallelogram for 'Parameter', an oval for 'Display', a hexagon for 'Action', a rounded rectangle for 'Mode', and a wavy-bottom rectangle for 'Sequential transfer'.</p> | |

10.1.30 VSCSAD: Vertical Scroll Start Address of RAM (37h)

| 37H | SCRLAR (Scroll Area) | | | | | | | | | | | | HEX |
|-------------|----------------------|-----|-----|-------|------|------|------|------|------|------|------|------|-------|
| Inst / Para | D/CX | WRX | RDX | D17-8 | D7 | D6 | D5 | D4 | D3 | D2 | D1 | D0 | HEX |
| VSCSAD | 0 | ↑ | 1 | - | 0 | 0 | 1 | 1 | 0 | 1 | 1 | 1 | (37h) |
| Parameter1 | 1 | ↑ | 1 | - | 0 | 0 | 0 | 0 | 0 | 0 | 0 | 0 | |
| Parameter2 | 1 | ↑ | 1 | - | SSA7 | SSA6 | SSA5 | SSA4 | SSA3 | SSA2 | SSA1 | SSA0 | - |

-This command is used together with Vertical Scrolling Definition (33h).
 -These two commands describe the scrolling area and the scrolling mode.
 -The Vertical Scrolling Start Address command has one parameter which describes which line in the Frame Memory will be written as the first line after the last line of the Top Fixed Area on the display as illustrated below:
 -This command Start the scrolling.
 -Exit from V-scrolling mode by commands Partial mode On (12h) or Normal mode On (13h)

Description

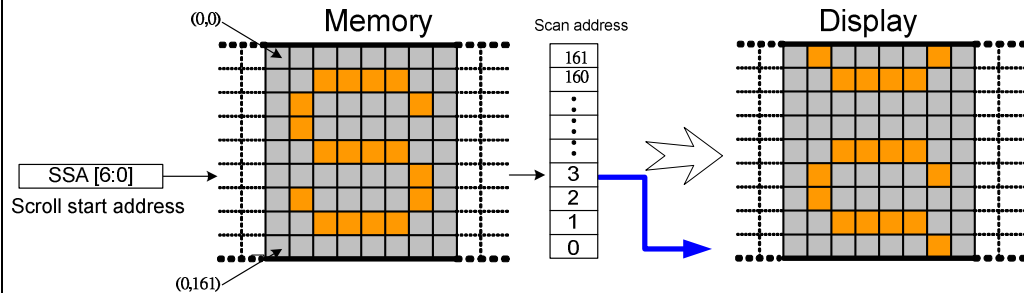
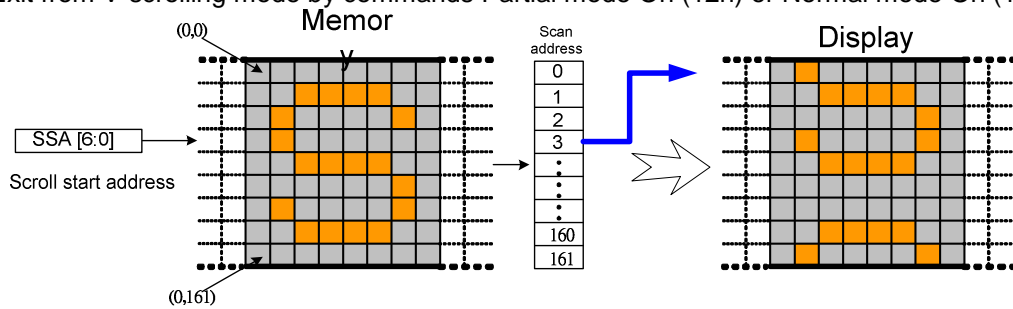

NOTE: When new Pointer position and Picture Data are sent, the result on the display will happen at the next Panel Scan to avoid tearing effect.
 SSA refers to the Frame Memory line Pointer

Restriction
 Since the value of the Vertical Scrolling Start Address is absolute (with reference to the Frame Memory), it must not enter the fixed area (defined by Vertical Scrolling Definition (33h))-otherwise undesirable image will be displayed on the Panel.
 SSA [6:0] is based on line unit.
 SSA [6:0] = 00h, 01h, 02h, 03h, ... , A1h

| Register Availability | Status | | Availability | |
|-----------------------|---|-----|--------------|--|
| | Normal Mode On, Idle Mode Off, Sleep Out | | Yes | |
| | Normal Mode On, Idle Mode On, Sleep Out | | Yes | |
| | Partial Mode On, Idle Mode Off, Sleep Out | | No | |
| | Partial Mode On, Idle Mode On, Sleep Out | | No | |
| Sleep In | | Yes | | |

| | | |
|------------|--|----------------------|
| Default | Status | Default Value |
| | Power On Sequence | 00h |
| | S/W Reset | 00h |
| | H/W Reset | 00h |
| Flow Chart | See Vertical Scrolling Definition (33h) description. | |

10.1.31 IDMOFF (38h): Idle Mode Off

| 38H | IDMOFF (Idle Mode Off) | | | | | | | | | | | | HEX |
|-------------|---|-----|-----|-------|----|----|---------------|----|----|----|----|----|-------|
| Inst / Para | D/CX | WRX | RDX | D17-8 | D7 | D6 | D5 | D4 | D3 | D2 | D1 | D0 | HEX |
| IDMOFF | 0 | ↑ | 1 | - | 0 | 0 | 1 | 1 | 1 | 0 | 0 | 0 | (38h) |
| Parameter | No Parameter | | | | | | | | | | | | - |
| Description | -This command is used to recover from Idle mode on. -In the idle off mode, 1. LCD can display 4096, 65k or 262k colors. 2. Normal frame frequency is applied. | | | | | | | | | | | | |
| Default | Status | | | | | | Default Value | | | | | | |
| | Power On Sequence | | | | | | Idle Mode Off | | | | | | |
| | S/W Reset | | | | | | Idle Mode Off | | | | | | |
| | | | | | | | Idle Mode Off | | | | | | |
| Flow Chart | <pre> graph TD A([Idle on mode]) --> B[/IDMOFF/] B --> C([Idle off mode]) </pre> <p>Legend</p> <ul style="list-style-type: none"> Command: Trapezoid Parameter: Parallelogram Display: Display shape Action: Hexagon Mode: Oval Sequential transfer: Wavy bottom | | | | | | | | | | | | |

10.1.32 IDMON (39h): Idle Mode On

| 39H | IDMON (Idle Mode On) | | | | | | | | | | | | HEX | | | | | | | | | | | | | | | | | | | | | | | |
|---|---|-------------------|-------------------|-------------------|-------------------|-------|--------|--------|--------|------|--------|--------|--------|--------------|--|--------|---|---------|---|--------|--|-------|----------|--------|--------|------|--------|--------|--------|--------|--------|--------|--------|-------|--------|--------|
| Inst / Para | D/CX | WRX | RDX | D17-8 | D7 | D6 | D5 | D4 | D3 | D2 | D1 | D0 | HEX | | | | | | | | | | | | | | | | | | | | | | | |
| IDMOFF | 0 | ↑ | 1 | - | 0 | 0 | 1 | 1 | 1 | 0 | 0 | 1 | (39h) | | | | | | | | | | | | | | | | | | | | | | | |
| Parameter | No Parameter | | | | | | | | | | | | - | | | | | | | | | | | | | | | | | | | | | | | |
| Description | <p>-This command is used to enter into Idle mode on. -There will be no abnormal visible effect on the display mode change transition. -In the idle on mode, 1. Color expression is reduced. The primary and the secondary colors using MSB of each R,G and B in the Frame Memory, 8 color depth data is displayed. 2. 8-Color mode frame frequency is applied. 3. Exit from IDMON by Idle Mode Off (38h) command</p> <p>(Example)</p> | | | | | | | | | | | | | | | | | | | | | | | | | | | | | | | | | | | |
| | <table border="1"> <thead> <tr> <th>Color</th> <th>R5 R4 R3 R2 R1 R0</th> <th>G5 G4 G3 G2 G1 G0</th> <th>B5 B4 B3 B4 B1 B0</th> </tr> </thead> <tbody> <tr> <td>Black</td> <td>0xxxxx</td> <td>0xxxxx</td> <td>0xxxxx</td> </tr> <tr> <td>Blue</td> <td>0xxxxx</td> <td>0xxxxx</td> <td>1xxxxx</td> </tr> <tr> <td>Red</td> <td>1xxxxx</td> <td>0xxxxx</td> <td>0xxxxx</td> </tr> <tr> <td>Magenta</td> <td>1xxxxx</td> <td>0xxxxx</td> <td>1xxxxx</td> </tr> <tr> <td>Green</td> <td>0xxxxx</td> <td>1xxxxx</td> <td>0xxxxx</td> </tr> <tr> <td>Cyan</td> <td>0xxxxx</td> <td>1xxxxx</td> <td>1xxxxx</td> </tr> <tr> <td>Yellow</td> <td>1xxxxx</td> <td>1xxxxx</td> <td>0xxxxx</td> </tr> <tr> <td>White</td> <td>1xxxxx</td> <td>1xxxxx</td> <td>1xxxxx</td> </tr> </tbody> </table> | Color | R5 R4 R3 R2 R1 R0 | G5 G4 G3 G2 G1 G0 | B5 B4 B3 B4 B1 B0 | Black | 0xxxxx | 0xxxxx | 0xxxxx | Blue | 0xxxxx | 0xxxxx | 1xxxxx | Red | 1xxxxx | 0xxxxx | 0xxxxx | Magenta | 1xxxxx | 0xxxxx | 1xxxxx | Green | 0xxxxx | 1xxxxx | 0xxxxx | Cyan | 0xxxxx | 1xxxxx | 1xxxxx | Yellow | 1xxxxx | 1xxxxx | 0xxxxx | White | 1xxxxx | 1xxxxx |
| Color | R5 R4 R3 R2 R1 R0 | G5 G4 G3 G2 G1 G0 | B5 B4 B3 B4 B1 B0 | | | | | | | | | | | | | | | | | | | | | | | | | | | | | | | | | |
| Black | 0xxxxx | 0xxxxx | 0xxxxx | | | | | | | | | | | | | | | | | | | | | | | | | | | | | | | | | |
| Blue | 0xxxxx | 0xxxxx | 1xxxxx | | | | | | | | | | | | | | | | | | | | | | | | | | | | | | | | | |
| Red | 1xxxxx | 0xxxxx | 0xxxxx | | | | | | | | | | | | | | | | | | | | | | | | | | | | | | | | | |
| Magenta | 1xxxxx | 0xxxxx | 1xxxxx | | | | | | | | | | | | | | | | | | | | | | | | | | | | | | | | | |
| Green | 0xxxxx | 1xxxxx | 0xxxxx | | | | | | | | | | | | | | | | | | | | | | | | | | | | | | | | | |
| Cyan | 0xxxxx | 1xxxxx | 1xxxxx | | | | | | | | | | | | | | | | | | | | | | | | | | | | | | | | | |
| Yellow | 1xxxxx | 1xxxxx | 0xxxxx | | | | | | | | | | | | | | | | | | | | | | | | | | | | | | | | | |
| White | 1xxxxx | 1xxxxx | 1xxxxx | | | | | | | | | | | | | | | | | | | | | | | | | | | | | | | | | |
| Register Availability | <table border="1"> <thead> <tr> <th>Status</th> <th>Availability</th> </tr> </thead> <tbody> <tr> <td>Normal Mode On, Idle Mode Off, Sleep Out</td> <td>Yes</td> </tr> <tr> <td>Normal Mode On, Idle Mode On, Sleep Out</td> <td>Yes</td> </tr> <tr> <td>Partial Mode On, Idle Mode Off, Sleep Out</td> <td>No</td> </tr> <tr> <td>Partial Mode On, Idle Mode On, Sleep Out</td> <td>No</td> </tr> <tr> <td>Sleep In</td> <td>Yes</td> </tr> </tbody> </table> | | | | | | | | | | | | Status | Availability | Normal Mode On, Idle Mode Off, Sleep Out | Yes | Normal Mode On, Idle Mode On, Sleep Out | Yes | Partial Mode On, Idle Mode Off, Sleep Out | No | Partial Mode On, Idle Mode On, Sleep Out | No | Sleep In | Yes | | | | | | | | | | | | |
| Status | Availability | | | | | | | | | | | | | | | | | | | | | | | | | | | | | | | | | | | |
| Normal Mode On, Idle Mode Off, Sleep Out | Yes | | | | | | | | | | | | | | | | | | | | | | | | | | | | | | | | | | | |
| Normal Mode On, Idle Mode On, Sleep Out | Yes | | | | | | | | | | | | | | | | | | | | | | | | | | | | | | | | | | | |
| Partial Mode On, Idle Mode Off, Sleep Out | No | | | | | | | | | | | | | | | | | | | | | | | | | | | | | | | | | | | |
| Partial Mode On, Idle Mode On, Sleep Out | No | | | | | | | | | | | | | | | | | | | | | | | | | | | | | | | | | | | |
| Sleep In | Yes | | | | | | | | | | | | | | | | | | | | | | | | | | | | | | | | | | | |

| | | |
|------------|--|---------------|
| Default | Status | Default Value |
| | Power On Sequence | Idle Mode Off |
| | S/W Reset | Idle Mode Off |
| | H/W Reset | Idle Mode Off |
| Flow Chart | <pre> graph TD A([Idle off mode]) --> B[/IDMON/] B --> C([Idle on mode]) </pre> | |
| | <div style="border: 1px dashed black; padding: 5px;"> <p>Legend</p> <ul style="list-style-type: none"> Command Parameter Display Action Mode Sequential transfer </div> | |

10.1.33 COLMOD (3Ah): Interface Pixel Format

| 3AH | COLMOD (3Ah): Interface Pixel Format | | | | | | | | | | | | |
|--|--|-----|--------------------|----------------------------|----|--------------------|--------------------|----|----|-------|-------|-------|-------|
| Inst / Para | D/CX | WRX | RDX | D17-8 | D7 | D6 | D5 | D4 | D3 | D2 | D1 | D0 | HEX |
| COLMOD | 0 | ↑ | 1 | - | 0 | 0 | 1 | 1 | 1 | 0 | 1 | 0 | (3Ah) |
| Parameter | 1 | ↑ | 1 | - | - | - | - | - | - | IFPF2 | IFPF1 | IFPF0 | |
| Description | This command is used to define the format of RGB picture data, which is to be transferred via the MCU interface. The formats are shown in the table: | | | | | | | | | | | | |
| | IFPF[2:0] | | | MCU Interface Color Format | | | | | | | | | |
| | 011 | 3 | 12-bit/pixel | | | | | | | | | | |
| | 101 | 5 | 16-bit/pixel | | | | | | | | | | |
| | 110 | 6 | 18-bit/pixel | | | | | | | | | | |
| | 111 | 7 | No used | | | | | | | | | | |
| <p>Note1: In 12-bit/Pixel, 16-bit/Pixel or 18-bit/Pixel mode, the LUT is applied to transfer data into the Frame Memory.</p> <p>Note2: The Command 3Ah should be set at 55h when writing 16-bit/pixel data into frame memory, but 3Ah should be re-set to 66h when reading pixel data from frame memory. Please check the LUT in chapter 9.17 when using memory read function.</p> | | | | | | | | | | | | | |
| Register Availability | Status | | | | | | Availability | | | | | | |
| | Normal Mode On, Idle Mode Off, Sleep Out | | | | | | Yes | | | | | | |
| | Normal Mode On, Idle Mode On, Sleep Out | | | | | | Yes | | | | | | |
| | Partial Mode On, Idle Mode Off, Sleep Out | | | | | | No | | | | | | |
| | Partial Mode On, Idle Mode On, Sleep Out | | | | | | No | | | | | | |
| Sleep In | | | | | | Yes | | | | | | | |
| Default | Status | | | Default Value | | | | | | | | | |
| | | | | IFPF[2:0] | | | VIPF[3:0] | | | | | | |
| | Power On Sequence | | | 0110(18-bit/Pixel) | | | 0110(18-bit/Pixel) | | | | | | |
| | S/W Reset | | | No Change | | | No Change | | | | | | |
| H/W Reset | | | 0110(18-bit/Pixel) | | | 0110(18-bit/Pixel) | | | | | | | |
| Flow Chart | <pre> graph TD A([18-bit/Pixel Mode]) --> B[/COLMOD/] B --> C[/1st Parameter/] C --> D([16-bit/Pixel Mode]) </pre> | | | | | | | | | | | | |

10.1.34 RDID1 (DAh): Read ID1 Value

| DAH | RDID1 (Read ID1 Value) | | | | | | | | | | | | |
|-----------------------|--|-----|-----|-------|------|------|---------------|------|------|------|------|------|-------|
| Inst / Para | D/CX | WRX | RDX | D17-8 | D7 | D6 | D5 | D4 | D3 | D2 | D1 | D0 | HEX |
| RDID1 | 0 | ↑ | 1 | - | 1 | 1 | 0 | 1 | 1 | 0 | 1 | 0 | (DAh) |
| 1st Parameter | 1 | 1 | ↑ | - | - | - | - | - | - | - | - | - | - |
| 2nd Parameter | 1 | 1 | ↑ | - | ID17 | ID16 | ID15 | ID14 | ID13 | ID12 | ID11 | ID10 | |
| Description | -This read byte returns 8-bit LCD module's manufacturer ID -The 1st parameter is dummy data -The 2nd parameter (ID17 to ID10): LCD module's manufacturer ID. NOTE: See command RDDID (04h), 2nd parameter. | | | | | | | | | | | | |
| Register Availability | Status | | | | | | Availability | | | | | | |
| | Normal Mode On, Idle Mode Off, Sleep Out | | | | | | Yes | | | | | | |
| | Normal Mode On, Idle Mode On, Sleep Out | | | | | | Yes | | | | | | |
| | Partial Mode On, Idle Mode Off, Sleep Out | | | | | | No | | | | | | |
| | Partial Mode On, Idle Mode On, Sleep Out | | | | | | No | | | | | | |
| Sleep In | | | | | | Yes | | | | | | | |
| Default | Status | | | | | | Default Value | | | | | | |
| | Power On Sequence | | | | | | 0x7C | | | | | | |
| | S/W Reset | | | | | | 0x7C | | | | | | |
| | H/W Reset | | | | | | 0x7C | | | | | | |
| Flow Chart | <div style="display: flex; justify-content: space-around;"> <div style="text-align: center;"> <p>Serial I/F Mode</p> </div> <div style="text-align: center;"> <p>Parallel I/F Mode</p> </div> </div> <div style="border: 1px dashed black; padding: 10px; margin-top: 20px;"> <p>Legend</p> <ul style="list-style-type: none"> Command Parameter Display Action Mode Sequential transfer </div> | | | | | | | | | | | | |

10.1.35 RDID2 (DBh): Read ID2 Value

| DBH | RDID2 (Read ID2 Value) | | | | | | | | | | | | |
|---|--|-----|-----|-------|---------|------|---------------|------|---------|------|------|------|-------|
| Inst / Para | D/CX | WRX | RDX | D17-8 | D7 | D6 | D5 | D4 | D3 | D2 | D1 | D0 | HEX |
| RDID2 | 0 | ↑ | 1 | - | 1 | 1 | 0 | 1 | 1 | 0 | 1 | 1 | (DBh) |
| 1 st Parameter | 1 | 1 | ↑ | - | - | - | - | - | - | - | - | - | - |
| 2 nd Parameter | 1 | 1 | ↑ | - | 1 | ID26 | ID25 | ID24 | ID23 | ID22 | ID21 | ID20 | |
| Description | -This read byte returns 8-bit LCD module/driver version ID -The 1 st parameter is dummy data -The 2 nd parameter (ID26 to ID20): LCD module/driver version ID -Parameter Range: ID=80h to FFh | | | | | | | | | | | | |
| | ID26 to ID20 | | | | Version | | | | Changes | | | | |
| | 80h | | | | | | | | | | | | |
| | 81h | | | | | | | | | | | | |
| | 82h | | | | | | | | | | | | |
| 83h | | | | | | | | | | | | | |
| NOTE: See command RDDID (04h), 3 rd parameter. | | | | | | | | | | | | | |
| Register Availability | Status | | | | | | Availability | | | | | | |
| | Normal Mode On, Idle Mode Off, Sleep Out | | | | | | Yes | | | | | | |
| | Normal Mode On, Idle Mode On, Sleep Out | | | | | | Yes | | | | | | |
| | Partial Mode On, Idle Mode Off, Sleep Out | | | | | | No | | | | | | |
| | Partial Mode On, Idle Mode On, Sleep Out | | | | | | No | | | | | | |
| Sleep In | | | | | | Yes | | | | | | | |
| Default | Status | | | | | | Default Value | | | | | | |
| | Power On Sequence | | | | | | NV Value | | | | | | |
| | S/W Reset | | | | | | NV Value | | | | | | |
| | H/W Reset | | | | | | NV Value | | | | | | |

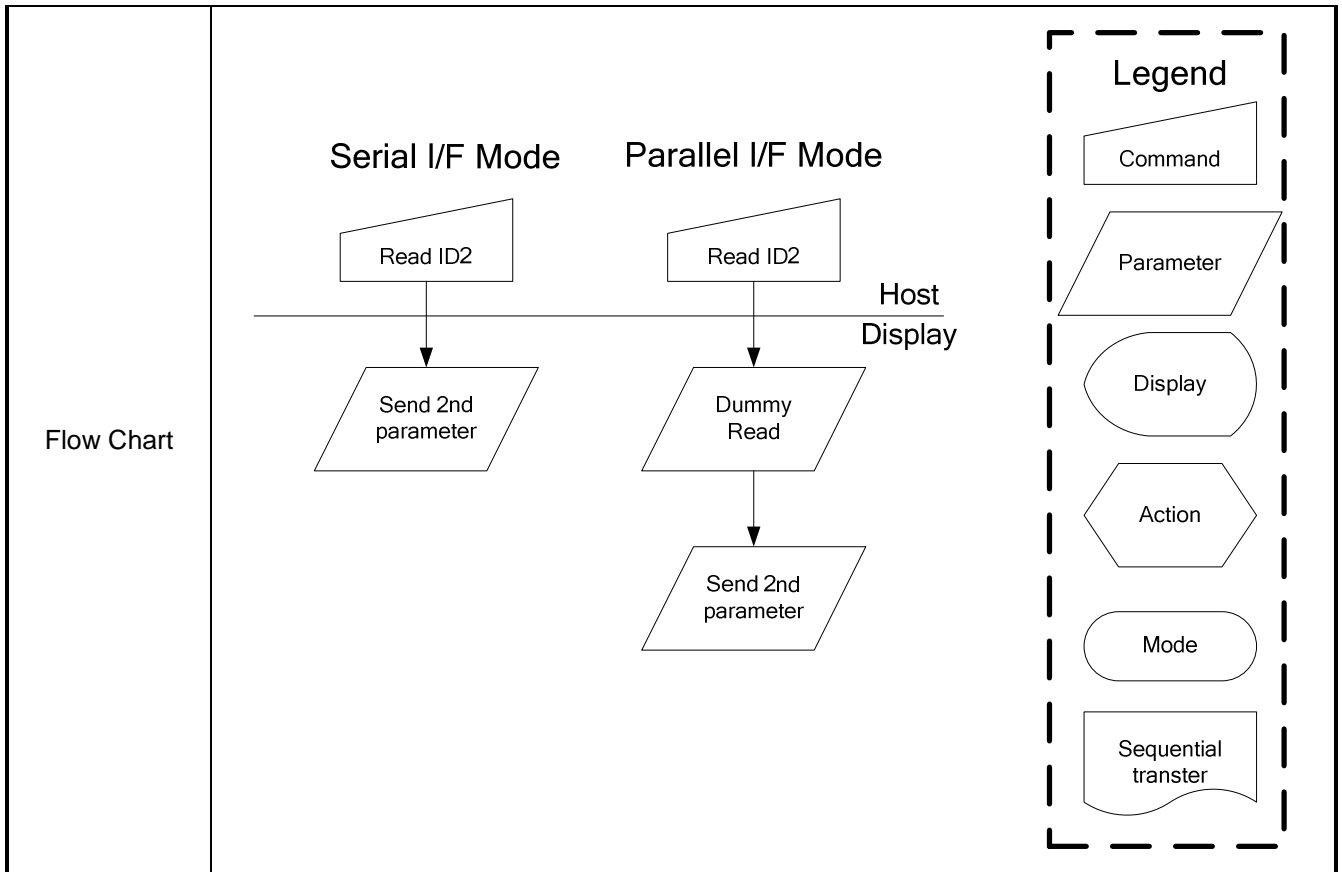

10.1.36 RDID3 (DCh): Read ID3 Value

| DCH | RDID3 (Read ID2 Value) | | | | | | | | | | | | |
|--|--|-----|-----|-------|------|------|-------------------|------|------|------|------|------|-------|
| Inst / Para | D/CX | WRX | RDX | D17-8 | D7 | D6 | D5 | D4 | D3 | D2 | D1 | D0 | HEX |
| RDID3 | 0 | ↑ | 1 | - | 1 | 1 | 0 | 1 | 1 | 1 | 0 | 0 | (DCh) |
| 1 st Parameter | 1 | 1 | ↑ | - | - | - | - | - | - | - | - | - | - |
| 2 nd Parameter | 1 | 1 | ↑ | - | ID37 | ID36 | ID35 | ID34 | ID33 | ID32 | ID31 | ID30 | |
| Description | -This read byte returns 8-bit LCD module/driver ID. -The 1 st parameter is dummy data -The 2 nd parameter (ID37 to ID30): LCD module/driver ID. NOTE: See command RDDID (04h), 4 th parameter. | | | | | | | | | | | | |
| Register Availability | Status | | | | | | Availability | | | | | | |
| | Normal Mode On, Idle Mode Off, Sleep Out | | | | | | Yes | | | | | | |
| | Normal Mode On, Idle Mode On, Sleep Out | | | | | | Yes | | | | | | |
| | Partial Mode On, Idle Mode Off, Sleep Out | | | | | | No | | | | | | |
| | Partial Mode On, Idle Mode On, Sleep Out | | | | | | No | | | | | | |
| Sleep In | | | | | | Yes | | | | | | | |
| Default | Status | | | | | | Default Value | | | | | | |
| | Power On Sequence | | | | | | NV Value | | | | | | |
| | S/W Reset | | | | | | NV Value | | | | | | |
| | H/W Reset | | | | | | NV Value | | | | | | |
| Flow Chart | Serial I/F Mode | | | | | | Parallel I/F Mode | | | | | | |
| | | | | | | | | | | | | | |
| <div style="border: 1px dashed black; padding: 5px;"> <p>Legend</p> <ul style="list-style-type: none"> Command Parameter Display Action Mode Sequential transfer </div> | | | | | | | | | | | | | |

10.2 Panel Function Command List and Description

Table 18 Panel Function Command List (1)

| Instruction | Refer | D/CX | WRX | RDX | D23-8 | D7 | D6 | D5 | D4 | D3 | D2 | D1 | D0 | Hex | Function |
|-------------|-------|------|-----|-----|-------|----|----|------|------|-------|-------|-------|-------|---------------------------|-------------------------------|
| FRMCTR1 | 0 | 0 | ↑ | 1 | - | 1 | 0 | 1 | 1 | 0 | 0 | 0 | 1 | (B1h) | In Normal Mode (Full Colors) |
| | | 1 | ↑ | 1 | - | | | | | RTNA3 | RTNA2 | RTNA1 | RTNA0 | | RTNA Set 1-line Period |
| | | 1 | ↑ | 1 | - | | | FPA5 | FPA4 | FPA3 | FPA2 | FPA1 | FPA0 | | FPA: Front Porch |
| | | 1 | ↑ | 1 | - | | | BPA5 | BPA4 | BPA3 | BPA2 | BPA1 | BPA0 | | BPA: Back Porch |
| FRMCTR2 | 0 | 0 | ↑ | 1 | - | 1 | 0 | 1 | 1 | 0 | 0 | 1 | 0 | (B2h) | In Idle Mode (8-colors) |
| | | 1 | ↑ | 1 | - | | | | | RTNB3 | RTNB2 | RTNB1 | RTNB0 | | RTNB: Set 1-line Period |
| | | 1 | ↑ | 1 | - | | | FPB5 | FPB4 | FPB3 | FPB2 | FPB1 | FPB0 | | FPB: Front Porch |
| | | 1 | ↑ | 1 | - | | | BPB5 | BPB4 | BPB3 | BPB2 | BPB1 | BPB0 | | BPB: Back Porch |
| FRMCTR3 | 0 | 0 | ↑ | 1 | - | 1 | 0 | 1 | 1 | 0 | 0 | 1 | 1 | (B3h) | In Partial Mode + Full Colors |
| | | 1 | ↑ | 1 | - | | | | | RTNC3 | RTNC2 | RTNC1 | RTNC0 | | RTNC,RTND: Set 1-line Period |
| | | 1 | ↑ | 1 | - | | | FPC5 | FPC4 | FPC3 | FPC2 | FPC1 | FPC0 | | FPC,FPD: Front Porch |
| | | 1 | ↑ | 1 | - | | | BPC5 | BPC4 | BPC3 | BPC2 | BPC1 | BPC0 | | BPC,BPD: Back Porch |
| | | 1 | ↑ | 1 | - | | | | | RTND3 | RTND2 | RTND1 | RTND0 | | |
| | | 1 | ↑ | 1 | - | | | FPD5 | FPD4 | FPD3 | FPD2 | FPD1 | FPD0 | | |
| | | 1 | ↑ | 1 | - | | | BPD5 | BPD4 | BPD3 | BPD2 | BPD1 | BPD0 | | |
| INVCTR | 0 | 0 | ↑ | 1 | - | 1 | 0 | 1 | 1 | 0 | 1 | 0 | 0 | (B4h) | Display Inversion Control |
| | | 1 | ↑ | 1 | - | 0 | 0 | 0 | 0 | 0 | NLA | NLB | NLC | NLA,NLB,NLC Set Inversion | |

Table 19 Panel Function Command List (2)

| Instruction | Refer | D/CX | WRX | RDX | D17-8 | D7 | D6 | D5 | D4 | D3 | D2 | D1 | D0 | Hex | Function |
|-------------|-------|------|-----|-----|-------|-----------|-----------|----------|---------|------------|------------|-----------|-----------------------|-------|--|
| PWCTR1 | 0 | 0 | ↑ | 1 | - | 1 | 1 | 0 | 0 | 0 | 0 | 0 | 0 | (C0h) | Power Control Setting |
| | | 1 | ↑ | 1 | - | AVDD [2] | AVDD [1] | AVDD [0] | VRHP 4 | VRHP 3 | VRHP 2 | VRHP 1 | VRHP 0 | | VRH: Set the GVDD Voltage |
| | | 1 | ↑ | 1 | - | 0 | 0 | 0 | VRHN 4 | VRHN 3 | VRHN 2 | VRHN 1 | VRHN 0 | | |
| | | 1 | ↑ | 1 | | MODE [1] | MODE [0] | 0 | 0 | 0 | 1 | 0 | 0 | | |
| 0 | ↑ | 1 | - | 1 | 1 | 0 | 0 | 0 | 0 | 0 | 1 | (C1h) | Power Control Setting | | |
| PWCTR2 | 0 | 1 | ↑ | 1 | - | VGH2 5[1] | VGH2 5[0] | - | - | VGLS EL[1] | VGLS EL[0] | VGHB T[1] | VGHB T[0] | | BT: Set VGH/ VGL Voltage |
| | | 0 | ↑ | 1 | - | 1 | 1 | 0 | 0 | 0 | 0 | 1 | 0 | (C2h) | In Normal Mode (Full Colors) |
| PWCTR3 | 0 | 1 | ↑ | 1 | - | DCA9 | DCA8 | SAPA 2 | SAPA 1 | SAPA 0 | APA2 | APA1 | APA0 | | APA: Adjust the Operational Amplifier DCA: Adjust the Booster Voltage |
| | | 0 | ↑ | 1 | - | DCA7 | DCA6 | DCA5 | DCA4 | DCA3 | DCA2 | DCA1 | DCA0 | | |
| PWCTR4 | 0 | 1 | ↑ | 1 | - | DCB9 | DCB8 | SAPB 2 | SAPB 1 | SAPB 0 | APB2 | APB1 | APB0 | | APB: Adjust the Operational Amplifier DCB: Adjust the Booster Voltage |
| | | 0 | ↑ | 1 | - | 1 | 1 | 0 | 0 | 0 | 0 | 1 | 1 | | |
| PWCTR5 | 0 | 1 | ↑ | 1 | - | DCC9 | DCC8 | SAPC 2 | SAPC 1 | SAPC 0 | APC2 | APC1 | APC0 | | APC: Adjust the Operational Amplifier DCC: Adjust the Booster Circuit for Idle mode |
| | | 1 | ↑ | 1 | - | DCC7 | DCC6 | DCC5 | DCC4 | DCC3 | DCC2 | DCC1 | DCC0 | | |
| | | 0 | ↑ | 1 | - | 1 | 1 | 0 | 0 | 0 | 1 | 0 | 0 | | |
| VMCTR1 | 0 | 1 | ↑ | 1 | - | - | - | VCOM S5 | VCOM S4 | VCOM S3 | VCOM S2 | VCOM S1 | VCOM S0 | | VCOM Voltage Control |
| | | 0 | ↑ | 1 | - | 1 | 1 | 0 | 0 | 0 | 1 | 1 | 1 | (C7h) | Set VCOM Offset control |
| VMOFCTR | 0 | 1 | ↑ | 1 | - | - | - | - | VMF4 | VMF3 | VMF2 | VMF1 | VMF0 | | |
| | | 0 | ↑ | 1 | - | 1 | 1 | 0 | 1 | 0 | 0 | 0 | 1 | (D1h) | |
| WRID2 | 0 | 1 | ↑ | 1 | - | - | ID2[6] | ID2[5] | ID2[4] | ID2[3] | ID2[2] | ID2[1] | ID2[0] | | Set LCM Version Code |

“-”: Don't care

Note 1: C0h to C7h are fixed for about power controller

Table 20 Panel Function Command List (3)

| Instruction | Refer | D/CX | WRX | RDX | D17-8 | D7 | D6 | D5 | D4 | D3 | D2 | D1 | D0 | Hex | Function |
|-------------|-------|------|-----|-----|-------|----------|----------|----------|----------|----------|----------|----------|----------|-------|-------------------------------|
| WRID3 | 0 | 0 | ↑ | 1 | - | 1 | 1 | 0 | 1 | 0 | 0 | 1 | 0 | (D2h) | Customer Project Code |
| | | 1 | ↑ | 1 | - | ID37 | ID36 | ID35 | ID34 | ID33 | ID32 | ID31 | ID30 | | Set the Project Code at ID3 |
| NVCTR1 | 0 | 0 | ↑ | 1 | - | 1 | 1 | 0 | 1 | 1 | 0 | 0 | 1 | (D9) | NVM Control Status |
| | | 1 | ↑ | 1 | - | 0 | VMF_EN | ID2_EN | 0 | 0 | 0 | 0 | EXT_R | | |
| NVCTR2 | 0 | 0 | ↑ | 1 | - | 1 | 1 | 0 | 1 | 1 | 1 | 1 | 0 | (Deh) | NVM Read Command |
| | | 1 | ↑ | 1 | - | 1 | 1 | 1 | 1 | 0 | 1 | 0 | 1 | F5 | |
| | | 1 | ↑ | 1 | - | 1 | 0 | 1 | 0 | 0 | 1 | 0 | 1 | A5 | Action Code |
| NVCTR3 | 0 | 0 | ↑ | 1 | - | 1 | 1 | 0 | 1 | 1 | 1 | 1 | 1 | (DFh) | NVM Write Command Action Code |
| | | 1 | ↑ | 1 | - | NVM_CMD7 | NVM_CMD6 | NVM_CMD5 | NVM_CMD4 | NVM_CMD3 | NVM_CMD2 | NVM_CMD1 | NVM_CMD0 | | |
| | | 1 | ↑ | 1 | - | 1 | 0 | 1 | 0 | 0 | 1 | 0 | 1 | A5 | |

“-“: Don't care

Note 1: The D1h to D3h registers are fixed for about ID code setting.

Note 2: The D9h, Deh and DFh registers are used for NV Memory function controller. (Ex: write, clear, etc.)

Table 21 Panel Function Command List (4)

| Instruction | Refer | D/CX | WRX | RDX | D17-8 | D7 | D6 | D5 | D4 | D3 | D2 | D1 | D0 | Hex | Function | |
|-------------|-------|----------|-----|-----|-------|-------------|-------------|-----------|-------------|-------------|-----------|-----------|-----------|-------------------------------|-------------------------------|----------|
| GAMCTRP1 | 0 | 0 | ↑ | 1 | - | 1 | 1 | 1 | 0 | 0 | 0 | 0 | 0 | (E0h) | Set | |
| | | 1 | ↑ | 1 | - | - | - | VRFP[5] | VRFP[4] | VRFP[3] | VRFP[2] | VRFP[1] | VRFP[0] | Gamma Adjustment (+ Polarity) | | |
| | | 1 | ↑ | 1 | - | - | - | VOS0P[5] | VOS0P[4] | VOS0P[3] | VOS0P[2] | VOS0P[1] | VOS0P[0] | | | |
| | | 1 | ↑ | 1 | - | - | - | PKP0[5] | PKP0[4] | PKP0[3] | PKP0[2] | PKP0[1] | PKP0[0] | | | |
| | | 1 | ↑ | 1 | - | - | - | PKP1[5] | PKP1[4] | PKP1[3] | PKP1[2] | PKP1[1] | PKP1[0] | | | |
| | | 1 | ↑ | 1 | - | - | - | PKP2[5] | PKP2[4] | PKP2[3] | PKP2[2] | PKP2[1] | PKP2[0] | | | |
| | | 1 | ↑ | 1 | - | - | - | PKP3[5] | PKP3[4] | PKP3[3] | PKP3[2] | PKP3[1] | PKP3[0] | | | |
| | | 1 | ↑ | 1 | - | - | - | PKP4[5] | PKP4[4] | PKP4[3] | PKP4[2] | PKP4[1] | PKP4[0] | | | |
| | | 1 | ↑ | 1 | - | - | - | PKP5[5] | PKP5[4] | PKP5[3] | PKP5[2] | PKP5[1] | PKP5[0] | | | |
| | | 1 | ↑ | 1 | - | - | - | PKP6[5] | PKP6[4] | PKP6[3] | PKP6[2] | PKP6[1] | PKP6[0] | | | |
| | | 1 | ↑ | 1 | - | - | - | PKP7[5] | PKP7[4] | PKP7[3] | PKP7[2] | PKP7[1] | PKP7[0] | | | |
| | | 1 | ↑ | 1 | - | - | - | PKP8[5] | PKP8[4] | PKP8[3] | PKP8[2] | PKP8[1] | PKP8[0] | | | |
| | | 1 | ↑ | 1 | - | - | - | PKP9[5] | PKP9[4] | PKP9[3] | PKP9[2] | PKP9[1] | PKP9[0] | | | |
| | | 1 | ↑ | 1 | - | - | - | SELV0P[5] | SELV0P[4] | SELV0P[3] | SELV0P[2] | SELV0P[1] | SELV0P[0] | | | |
| | | 1 | ↑ | 1 | - | - | - | SELV1P[5] | SELV1P[4] | SELV1P[3] | SELV1P[2] | SELV1P[1] | SELV1P[0] | | | |
| | | GAMCTRN1 | 0 | 0 | ↑ | 1 | - | 1 | 1 | 1 | 0 | 0 | 0 | | 0 | 1 |
| 1 | ↑ | | | 1 | - | - | - | VRF0N[5] | VRF0N[4] | VRF0N[3] | VRF0N[2] | VRF0N[1] | VRF0N[0] | | Gamma Adjustment (- Polarity) | |
| 1 | ↑ | | | 1 | - | - | - | VOS0N[5] | VOS0N[4] | VOS0N[3] | VOS0N[2] | VOS0N[1] | VOS0N[0] | | | |
| 1 | ↑ | | | 1 | - | - | - | PKN0[5] | PKN0[4] | PKN0[3] | PKN0[2] | PKN0[1] | PKN0[0] | | | |
| 1 | ↑ | | | 1 | - | - | - | PKN1[5] | PKN1[4] | PKN1[3] | PKN1[2] | PKN1[1] | PKN1[0] | | | |
| 1 | ↑ | | | 1 | - | - | - | PKN2[5] | PKN2[4] | PKN2[3] | PKN2[2] | PKN2[1] | PKN2[0] | | | |
| 1 | ↑ | | | 1 | - | - | - | PKN3[5] | PKN3[4] | PKN3[3] | PKN3[2] | PKN3[1] | PKN3[0] | | | |
| 1 | ↑ | | | 1 | - | - | - | PKN4[5] | PKN4[4] | PKN4[3] | PKN4[2] | PKN4[1] | PKN4[0] | | | |
| 1 | ↑ | | | 1 | - | - | - | PKN5[5] | PKN5[4] | PKN5[3] | PKN5[2] | PKN5[1] | PKN5[0] | | | |
| 1 | ↑ | | | 1 | - | - | - | PKN6[5] | PKN6[4] | PKN6[3] | PKN6[2] | PKN6[1] | PKN6[0] | | | |
| 1 | ↑ | | | 1 | - | - | - | PKN7[5] | PKN7[4] | PKN7[3] | PKN7[2] | PKN7[1] | PKN7[0] | | | |
| 1 | ↑ | | | 1 | - | - | - | PKN8[5] | PKN8[4] | PKN8[3] | PKN8[2] | PKN8[1] | PKN8[0] | | | |
| 1 | ↑ | | | 1 | - | - | - | PKN9[5] | PKN9[4] | PKN9[3] | PKN9[2] | PKN9[1] | PKN9[0] | | | |
| 1 | ↑ | | | 1 | - | - | - | SELV0N[5] | SELV0N[4] | SELV0N[3] | SELV0N[2] | SELV0N[1] | SELV0N[0] | | | |
| 1 | ↑ | | | 1 | - | - | - | SELV1N[5] | SELV1N[4] | SELV1N[3] | SELV1N[2] | SELV1N[1] | SELV1N[0] | | | |
| GCV | 0 | | | 1 | ↑ | 1 | - | 1 | 1 | 0 | 1 | 1 | 0 | 0 | | 0 |
| | | 1 | ↑ | 1 | - | GCV Enable1 | GCV Enable0 | 0 | Clk_Visible | Clk_Visible | | 0 | 0 | | | Variable |

“-”: Don't care

Note 1: E0-E1 registers are fixed for adjusting Gamma

10.2.1 FRMCTR1 (B1h): Frame Rate Control (In normal mode/ Full colors)

| B1H | FRMCTR1 (Frame Rate Control) | | | | | | | | | | | | |
|---------------------------|---|-----|----------------|----------------|----------------|----|------|------|-----------|-----------|-----------|-----------|-------|
| Inst / Para | D/CX | WRX | RDX | D17-8 | D7 | D6 | D5 | D4 | D3 | D2 | D1 | D0 | HEX |
| FRMCTR1 | 0 | ↑ | 1 | - | 1 | 0 | 1 | 1 | 0 | 0 | 0 | 1 | (B1h) |
| 1 st Parameter | 1 | ↑ | 1 | - | - | - | - | - | RTNA 3 | RTNA 2 | RTNA 1 | RTNA 0 | |
| 2 nd Parameter | 1 | ↑ | 1 | - | - | - | FPA5 | FPA4 | FPA3 | FPA2 | FPA1 | FPA0 | |
| 3 rd Parameter | 1 | ↑ | 1 | - | - | - | BPA5 | BPA4 | BPA3 | BPA2 | BPA1 | BPA0 | |
| Description | -Set the frame frequency of the full colors normal mode. - Frame rate=fosc/((RTNA x 2 + 40) x (LINE + FPA + BPA +2)) -fosc = 850kHz -FPA > 0, BPA > 0 | | | | | | | | | | | | |
| Default | Status | | Default Value | | | | | | | | | | |
| | | | GM[1:0] = "00" | GM[1:0] = "01" | GM[1:0] = "11" | | | | | | | | |
| | Power On Sequence | | 05h/3Ah/3Ah | 08h/3Bh/3Bh | 05h/3Ch/3Ch | | | | | | | | |
| | S/W Reset | | 05h/3Ah/3Ah | 08h/3Bh/3Bh | 05h/3Ch/3Ch | | | | | | | | |
| | H/W Reset | | 05h/3Ah/3Ah | 08h/3Bh/3Bh | 05h/3Ch/3Ch | | | | | | | | |
| Flow Chart | <pre> graph TD FRMCTR1[FRMCTR1] --> Param[1st Parameter 2nd parameter] </pre> <p>Legend</p> <ul style="list-style-type: none"> Command (Trapezoid) Parameter (Parallelogram) Display (Oval) Action (Hexagon) Mode (Rounded rectangle) Sequential transfer (Wavy-bottom rectangle) | | | | | | | | | | | | |

10.2.2 FRMCTR2 (B2h): Frame Rate Control (In Idle mode/ 8-colors)

| B2H | FRMCTR2 (Frame Rate Control) | | | | | | | | | | | | |
|---------------------------|---|-------------|----------------|----------------|----------------|----|------|------|-----------|-----------|-----------|-----------|-------|
| Inst / Para | D/CX | WRX | RDX | D17-8 | D7 | D6 | D5 | D4 | D3 | D2 | D1 | D0 | HEX |
| FRMCTR2 | 0 | ↑ | 1 | - | 1 | 0 | 1 | 1 | 0 | 0 | 1 | 0 | (B2h) |
| 1 st parameter | 1 | ↑ | 1 | - | - | - | - | - | RTNB 3 | RTNB 2 | RTNB 1 | RTNB 0 | |
| 2 nd parameter | 1 | ↑ | 1 | - | - | - | FPB5 | FPB4 | FPB3 | FPB2 | FPB1 | FPB0 | |
| 3 rd parameter | 1 | ↑ | 1 | - | - | - | BPB5 | BPB4 | BPB3 | BPB2 | BPB1 | BPB0 | |
| Description | -Set the frame frequency of the Idle mode. - Frame rate=fosc/((RTNA x 2 + 40) x (LINE + FPB + BPB +2)) -fosc = 850kHz -FPB > 0, BPB > 0 | | | | | | | | | | | | |
| Default | Status | | Default Value | | | | | | | | | | |
| | | | GM[1:0] = "00" | GM[1:0] = "01" | GM[1:0] = "11" | | | | | | | | |
| | Power On Sequence | | 05h/3Ah/3Ah | 08h/3Bh/3Bh | 05h/3Ch/3Ch | | | | | | | | |
| | S/W Reset | | 05h/3Ah/3Ah | 08h/3Bh/3Bh | 05h/3Ch/3Ch | | | | | | | | |
| H/W Reset | | 05h/3Ah/3Ah | 08h/3Bh/3Bh | 05h/3Ch/3Ch | | | | | | | | | |
| Flow Chart | <pre> graph TD FRMCTR2[FRMCTR2] --> Param[1st Parameter 2nd parameter] </pre> <p>Legend</p> <ul style="list-style-type: none"> Command (trapezoid) Parameter (parallelogram) Display (oval) Action (hexagon) Mode (rounded rectangle) Sequential transfer (wavy-bottom rectangle) | | | | | | | | | | | | |

10.2.3 FRMCTR3 (B3h): Frame Rate Control (In Partial mode/ full colors)

| B3H | FRMCTR3 (Frame Rate Control) | | | | | | | | | | | | |
|---------------------------|---|-------------|----------------|-------|-------------|----------------|------|-------------|----------------|------|------|------|-------|
| Inst / Para | D/CX | WRX | RDX | D17-8 | D7 | D6 | D5 | D4 | D3 | D2 | D1 | D0 | HEX |
| FRMCTR3 | 0 | ↑ | 1 | - | 1 | 0 | 1 | 1 | 0 | 0 | 1 | 1 | (B3h) |
| 1 st parameter | 1 | ↑ | 1 | - | - | - | - | - | RTNC | RTNC | RTNC | RTNC | |
| 2 nd parameter | 1 | ↑ | 1 | - | - | - | FPC5 | FPC4 | FPC3 | FPC2 | FPC1 | FPC0 | |
| 3 rd parameter | 1 | ↑ | 1 | - | - | - | BPC5 | BPC4 | BPC3 | BPC2 | BPC1 | BPC0 | |
| 4 th parameter | 1 | ↑ | 1 | - | - | - | - | - | RTND | RTND | RTND | RTND | |
| 5 th parameter | 1 | ↑ | 1 | - | - | - | FPD5 | FPD4 | FPD3 | FPD2 | FPD1 | FPD0 | |
| 6 th parameter | 1 | ↑ | 1 | - | - | - | BPD5 | BPD4 | BPD3 | BPD2 | BPD1 | BPD0 | |
| Description | -Set the frame frequency of the Partial mode/ full colors. - 1 st parameter to 3 rd parameter are used in dot inversion mode. - 4 th parameter to 6 th parameter are used in column inversion mode. - Frame rate=fosc/((RTNA x 2 + 40) x (LINE + FPC + BPC +2)) -fosc = 850kHz -FPC > 0, BPC > 0 | | | | | | | | | | | | |
| Default | Status | | Default Value | | | | | | | | | | |
| | | | GM[1:0] = "00" | | | GM[1:0] = "01" | | | GM[1:0] = "11" | | | | |
| | Power On Sequence | | 05h/3Ah/3Ah | | | 08h/3Bh/3Bh | | | 05h/3Ch/3Ch | | | | |
| | | | 05h/3Ah/3Ah | | | 08h/3Bh/3Bh | | | 05h/3Ch/3Ch | | | | |
| | S/W Reset | | 05h/3Ah/3Ah | | | 08h/3Bh/3Bh | | | 05h/3Ch/3Ch | | | | |
| | | 05h/3Ah/3Ah | | | 08h/3Bh/3Bh | | | 05h/3Ch/3Ch | | | | | |
| H/W Reset | | 05h/3Ah/3Ah | | | 08h/3Bh/3Bh | | | 05h/3Ch/3Ch | | | | | |
| | | 05h/3Ah/3Ah | | | 08h/3Bh/3Bh | | | 05h/3Ch/3Ch | | | | | |
| Flow Chart | <pre> graph TD FRMCTR3[FRMCTR3] --> Param[1st Parameter 6nd parameter] </pre> <p>Legend</p> <ul style="list-style-type: none"> Command (trapezoid) Parameter (parallelogram) Display (oval) Action (hexagon) Mode (rounded rectangle) Sequential transter (wavy-bottom rectangle) | | | | | | | | | | | | |

10.2.4 INVCTR (B4h): Display Inversion Control

| B4H | INVCTR (Display Inversion Control) | | | | | | | | | | | | |
|-------------|---|---|--|-------|----|----|----|---------------|----|-----|-----|-----|-------|
| Inst / Para | D/CX | WRX | RDX | D17-8 | D7 | D6 | D5 | D4 | D3 | D2 | D1 | D0 | HEX |
| INVCTR | 0 | ↑ | 1 | - | 1 | 0 | 1 | 1 | 0 | 1 | 0 | 0 | (B4h) |
| Parameter | 1 | ↑ | 1 | - | 0 | 0 | 0 | 0 | 0 | NLA | NLB | NLC | |
| Description | -Display Inversion mode control | | | | | | | | | | | | |
| | -NLA: Inversion setting in full colors normal mode (Normal mode on) | | | | | | | | | | | | |
| | NLA | | Inversion setting in full Colors normal mode | | | | | | | | | | |
| | 0 | | Dot Inversion | | | | | | | | | | |
| | 1 | | Column Inversion | | | | | | | | | | |
| | -NLB: Inversion setting in Idle mode (Idle mode on) | | | | | | | | | | | | |
| | NLB | | Inversion setting in Idle mode | | | | | | | | | | |
| | 0 | | Dot Inversion | | | | | | | | | | |
| | 1 | | Column Inversion | | | | | | | | | | |
| | -NLC: Inversion setting in full colors partial mode (Partial mode on / Idle mode off) | | | | | | | | | | | | |
| NLC | | Inversion setting in full Colors partial mode | | | | | | | | | | | |
| 0 | | Dot Inversion | | | | | | | | | | | |
| 1 | | Column Inversion | | | | | | | | | | | |
| Default | | | Status | | | | | Default Value | | | | | |
| | | | | | | | | B4h | | | | | |
| | | | Power On Sequence | | | | | 07h | | | | | |
| | | | S/W Reset | | | | | 07h | | | | | |
| | | | H/W Reset | | | | | 07h | | | | | |
| Flow Chart | <pre> graph TD INVCTR[INVCTR] --> Param[/1st Parameter/] </pre> | | | | | | | | | | | | |
| | <p>Legend</p> <ul style="list-style-type: none"> Command Parameter Display Action Mode Sequential transfer | | | | | | | | | | | | |

10.2.5 PWCTR1 (C0h): Power Control 1

| C0H | PWCTR1 (Power Control 1) | | | | | | | | | | | | | | | | | | | | | | | | | | | | | | | | | | | | | | | | | | | | | | | | | | | | | | | | | | | | | | | | | | | | | | | | | | | | | | | | | | | | | | | | | | | | | | | | | | | | | | | | | | | | | | | | | | | | | | | | | | | | | | | | | | | | | | | | | | | | | | | | | | | | | | | | | | | | | | | | | | | | | | | | | | | | | | | | | | | | | | | | | | | | | | | | | | | | | | | | | | | | | | | | | |
|---------------------------|--------------------------|--|--|-------|---|---------|---------|-----------|-------|-------|-------|-------|-------|-------|------|------|-------|-----|-----|-------|------|------|-------|-----|-----|-------|------|------|-------|---|--|-----------|----------|----|-------|-----|--|-------|------|----|--|-----|--|-------|------|--|-------|-----|--|-------|------|--|-------|---|--|-------|------|--|-------|-----|--|-------|------|--|-------|-----|--|-------|------|--|-------|-----|--|-------|------|--|-------|-----|--|-------|------|--|-------|-----|--|-------|------|--|-------|-----|--|-------|------|--|-------|-----|--|-------|------|--|-------|-----|--|-------|------|--|--|--|---------|---|---|-----------|------|------|-------|------|----|-------|-------|-------|-------|------|------|-------|-------|-------|-------|------|------|-------|-------|-------|-------|------|--|-------|-------|--|-------|------|--|-------|-------|--|-------|------|--|-------|-------|--|-------|------|--|-------|-------|--|-------|----|--|-------|-------|--|-------|------|--|-------|-------|--|-------|------|--|-------|-------|--|-------|------|--|-------|-------|--|-------|------|--|-------|-------|--|-------|------|--|-------|-------|--|-------|------|--|-------|-------|--|-------|------|--|-------|-------|--|-------|------|--|-------|-------|--|
| Inst / Para | D/CX | WRX | RDX | D17-8 | D7 | D6 | D5 | D4 | D3 | D2 | D1 | D0 | HEX | | | | | | | | | | | | | | | | | | | | | | | | | | | | | | | | | | | | | | | | | | | | | | | | | | | | | | | | | | | | | | | | | | | | | | | | | | | | | | | | | | | | | | | | | | | | | | | | | | | | | | | | | | | | | | | | | | | | | | | | | | | | | | | | | | | | | | | | | | | | | | | | | | | | | | | | | | | | | | | | | | | | | | | | | | | | | | | | | | | | | | | | | | | | | | | | | | | | | |
| PWCTR1 | 0 | ↑ | 1 | - | 1 | 1 | 0 | 0 | 0 | 0 | 0 | 0 | (C0h) | | | | | | | | | | | | | | | | | | | | | | | | | | | | | | | | | | | | | | | | | | | | | | | | | | | | | | | | | | | | | | | | | | | | | | | | | | | | | | | | | | | | | | | | | | | | | | | | | | | | | | | | | | | | | | | | | | | | | | | | | | | | | | | | | | | | | | | | | | | | | | | | | | | | | | | | | | | | | | | | | | | | | | | | | | | | | | | | | | | | | | | | | | | | | | | | | | | | | |
| 1 st parameter | 1 | ↑ | 1 | - | AVDD[2] | AVDD[1] | AVDD[0] | VRHP4 | VRHP3 | VRHP2 | VRHP1 | VRHP0 | | | | | | | | | | | | | | | | | | | | | | | | | | | | | | | | | | | | | | | | | | | | | | | | | | | | | | | | | | | | | | | | | | | | | | | | | | | | | | | | | | | | | | | | | | | | | | | | | | | | | | | | | | | | | | | | | | | | | | | | | | | | | | | | | | | | | | | | | | | | | | | | | | | | | | | | | | | | | | | | | | | | | | | | | | | | | | | | | | | | | | | | | | | | | | | | | | | | | | |
| 2 nd parameter | 1 | ↑ | 1 | - | 0 | 0 | 0 | VRHN4 | VRHN3 | VRHN2 | VRHN1 | VRHN0 | | | | | | | | | | | | | | | | | | | | | | | | | | | | | | | | | | | | | | | | | | | | | | | | | | | | | | | | | | | | | | | | | | | | | | | | | | | | | | | | | | | | | | | | | | | | | | | | | | | | | | | | | | | | | | | | | | | | | | | | | | | | | | | | | | | | | | | | | | | | | | | | | | | | | | | | | | | | | | | | | | | | | | | | | | | | | | | | | | | | | | | | | | | | | | | | | | | | | | |
| 3 rd parameter | 1 | ↑ | 1 | - | MODE[1] | MODE[0] | 0 | 0 | 0 | 1 | VRHN5 | VRHP5 | | | | | | | | | | | | | | | | | | | | | | | | | | | | | | | | | | | | | | | | | | | | | | | | | | | | | | | | | | | | | | | | | | | | | | | | | | | | | | | | | | | | | | | | | | | | | | | | | | | | | | | | | | | | | | | | | | | | | | | | | | | | | | | | | | | | | | | | | | | | | | | | | | | | | | | | | | | | | | | | | | | | | | | | | | | | | | | | | | | | | | | | | | | | | | | | | | | | | | |
| Description | | | | | <table border="1"> <thead> <tr> <th>AVDD[2:0]</th> <th>AVDD</th> </tr> </thead> <tbody> <tr><td>000</td><td>4.5</td></tr> <tr><td>001</td><td>4.6</td></tr> <tr><td>010</td><td>4.7</td></tr> <tr><td>011</td><td>4.8</td></tr> <tr><td>100</td><td>4.9</td></tr> <tr><td>101</td><td>5</td></tr> <tr><td>110</td><td>5.1</td></tr> <tr><td>111</td><td>5.2</td></tr> </tbody> </table> | | | AVDD[2:0] | AVDD | 000 | 4.5 | 001 | 4.6 | 010 | 4.7 | 011 | 4.8 | 100 | 4.9 | 101 | 5 | 110 | 5.1 | 111 | 5.2 | | | | | <table border="1"> <thead> <tr> <th>MODE[1:0]</th> <th>FUNCTION</th> </tr> </thead> <tbody> <tr><td>00</td><td>2X</td></tr> <tr><td>01</td><td>Don't use this setting, reserve for testing.</td></tr> <tr><td>10</td><td>AUTO</td></tr> <tr><td>11</td><td>Don't use this setting, reserve for testing.</td></tr> </tbody> </table> | | MODE[1:0] | FUNCTION | 00 | 2X | 01 | Don't use this setting, reserve for testing. | 10 | AUTO | 11 | Don't use this setting, reserve for testing. | | | | | | | | | | | | | | | | | | | | | | | | | | | | | | | | | | | | | | | | | | | | | | | | | | | | | | | | | | | | | | | | | | | | | | | | | | | | | | | | | | | | | | | | | | | | | | | | | | | | | | | | | | | | | | | | | | | | | | | | | | | | | | | | | | | | | | | | | | | | | | | | | | | | | | | | | | | | | | | | | | | | | | | | | |
| | AVDD[2:0] | AVDD | | | | | | | | | | | | | | | | | | | | | | | | | | | | | | | | | | | | | | | | | | | | | | | | | | | | | | | | | | | | | | | | | | | | | | | | | | | | | | | | | | | | | | | | | | | | | | | | | | | | | | | | | | | | | | | | | | | | | | | | | | | | | | | | | | | | | | | | | | | | | | | | | | | | | | | | | | | | | | | | | | | | | | | | | | | | | | | | | | | | | | | | | | | | | | | | | | | | | | | | | | | | | | | | |
| | 000 | 4.5 | | | | | | | | | | | | | | | | | | | | | | | | | | | | | | | | | | | | | | | | | | | | | | | | | | | | | | | | | | | | | | | | | | | | | | | | | | | | | | | | | | | | | | | | | | | | | | | | | | | | | | | | | | | | | | | | | | | | | | | | | | | | | | | | | | | | | | | | | | | | | | | | | | | | | | | | | | | | | | | | | | | | | | | | | | | | | | | | | | | | | | | | | | | | | | | | | | | | | | | | | | | | | | | | |
| | 001 | 4.6 | | | | | | | | | | | | | | | | | | | | | | | | | | | | | | | | | | | | | | | | | | | | | | | | | | | | | | | | | | | | | | | | | | | | | | | | | | | | | | | | | | | | | | | | | | | | | | | | | | | | | | | | | | | | | | | | | | | | | | | | | | | | | | | | | | | | | | | | | | | | | | | | | | | | | | | | | | | | | | | | | | | | | | | | | | | | | | | | | | | | | | | | | | | | | | | | | | | | | | | | | | | | | | | | |
| | 010 | 4.7 | | | | | | | | | | | | | | | | | | | | | | | | | | | | | | | | | | | | | | | | | | | | | | | | | | | | | | | | | | | | | | | | | | | | | | | | | | | | | | | | | | | | | | | | | | | | | | | | | | | | | | | | | | | | | | | | | | | | | | | | | | | | | | | | | | | | | | | | | | | | | | | | | | | | | | | | | | | | | | | | | | | | | | | | | | | | | | | | | | | | | | | | | | | | | | | | | | | | | | | | | | | | | | | | |
| | 011 | 4.8 | | | | | | | | | | | | | | | | | | | | | | | | | | | | | | | | | | | | | | | | | | | | | | | | | | | | | | | | | | | | | | | | | | | | | | | | | | | | | | | | | | | | | | | | | | | | | | | | | | | | | | | | | | | | | | | | | | | | | | | | | | | | | | | | | | | | | | | | | | | | | | | | | | | | | | | | | | | | | | | | | | | | | | | | | | | | | | | | | | | | | | | | | | | | | | | | | | | | | | | | | | | | | | | | |
| | 100 | 4.9 | | | | | | | | | | | | | | | | | | | | | | | | | | | | | | | | | | | | | | | | | | | | | | | | | | | | | | | | | | | | | | | | | | | | | | | | | | | | | | | | | | | | | | | | | | | | | | | | | | | | | | | | | | | | | | | | | | | | | | | | | | | | | | | | | | | | | | | | | | | | | | | | | | | | | | | | | | | | | | | | | | | | | | | | | | | | | | | | | | | | | | | | | | | | | | | | | | | | | | | | | | | | | | | | |
| | 101 | 5 | | | | | | | | | | | | | | | | | | | | | | | | | | | | | | | | | | | | | | | | | | | | | | | | | | | | | | | | | | | | | | | | | | | | | | | | | | | | | | | | | | | | | | | | | | | | | | | | | | | | | | | | | | | | | | | | | | | | | | | | | | | | | | | | | | | | | | | | | | | | | | | | | | | | | | | | | | | | | | | | | | | | | | | | | | | | | | | | | | | | | | | | | | | | | | | | | | | | | | | | | | | | | | | | |
| | 110 | 5.1 | | | | | | | | | | | | | | | | | | | | | | | | | | | | | | | | | | | | | | | | | | | | | | | | | | | | | | | | | | | | | | | | | | | | | | | | | | | | | | | | | | | | | | | | | | | | | | | | | | | | | | | | | | | | | | | | | | | | | | | | | | | | | | | | | | | | | | | | | | | | | | | | | | | | | | | | | | | | | | | | | | | | | | | | | | | | | | | | | | | | | | | | | | | | | | | | | | | | | | | | | | | | | | | | |
| | 111 | 5.2 | | | | | | | | | | | | | | | | | | | | | | | | | | | | | | | | | | | | | | | | | | | | | | | | | | | | | | | | | | | | | | | | | | | | | | | | | | | | | | | | | | | | | | | | | | | | | | | | | | | | | | | | | | | | | | | | | | | | | | | | | | | | | | | | | | | | | | | | | | | | | | | | | | | | | | | | | | | | | | | | | | | | | | | | | | | | | | | | | | | | | | | | | | | | | | | | | | | | | | | | | | | | | | | | |
| | MODE[1:0] | FUNCTION | | | | | | | | | | | | | | | | | | | | | | | | | | | | | | | | | | | | | | | | | | | | | | | | | | | | | | | | | | | | | | | | | | | | | | | | | | | | | | | | | | | | | | | | | | | | | | | | | | | | | | | | | | | | | | | | | | | | | | | | | | | | | | | | | | | | | | | | | | | | | | | | | | | | | | | | | | | | | | | | | | | | | | | | | | | | | | | | | | | | | | | | | | | | | | | | | | | | | | | | | | | | | | | | |
| | 00 | 2X | | | | | | | | | | | | | | | | | | | | | | | | | | | | | | | | | | | | | | | | | | | | | | | | | | | | | | | | | | | | | | | | | | | | | | | | | | | | | | | | | | | | | | | | | | | | | | | | | | | | | | | | | | | | | | | | | | | | | | | | | | | | | | | | | | | | | | | | | | | | | | | | | | | | | | | | | | | | | | | | | | | | | | | | | | | | | | | | | | | | | | | | | | | | | | | | | | | | | | | | | | | | | | | | |
| | 01 | Don't use this setting, reserve for testing. | | | | | | | | | | | | | | | | | | | | | | | | | | | | | | | | | | | | | | | | | | | | | | | | | | | | | | | | | | | | | | | | | | | | | | | | | | | | | | | | | | | | | | | | | | | | | | | | | | | | | | | | | | | | | | | | | | | | | | | | | | | | | | | | | | | | | | | | | | | | | | | | | | | | | | | | | | | | | | | | | | | | | | | | | | | | | | | | | | | | | | | | | | | | | | | | | | | | | | | | | | | | | | | | |
| | 10 | AUTO | | | | | | | | | | | | | | | | | | | | | | | | | | | | | | | | | | | | | | | | | | | | | | | | | | | | | | | | | | | | | | | | | | | | | | | | | | | | | | | | | | | | | | | | | | | | | | | | | | | | | | | | | | | | | | | | | | | | | | | | | | | | | | | | | | | | | | | | | | | | | | | | | | | | | | | | | | | | | | | | | | | | | | | | | | | | | | | | | | | | | | | | | | | | | | | | | | | | | | | | | | | | | | | | |
| | 11 | Don't use this setting, reserve for testing. | | | | | | | | | | | | | | | | | | | | | | | | | | | | | | | | | | | | | | | | | | | | | | | | | | | | | | | | | | | | | | | | | | | | | | | | | | | | | | | | | | | | | | | | | | | | | | | | | | | | | | | | | | | | | | | | | | | | | | | | | | | | | | | | | | | | | | | | | | | | | | | | | | | | | | | | | | | | | | | | | | | | | | | | | | | | | | | | | | | | | | | | | | | | | | | | | | | | | | | | | | | | | | | | |
| | | | <table border="1"> <thead> <tr> <th>VRHP[5]</th> <th>0</th> <th>1</th> </tr> </thead> <tbody> <tr> <th>VRHP[4:0]</th> <th>GVDD</th> <th>GVDD</th> </tr> <tr><td>00000</td><td>4.7</td><td>5</td></tr> <tr><td>00001</td><td>4.65</td><td>4.95</td></tr> <tr><td>00010</td><td>4.6</td><td>4.9</td></tr> <tr><td>00011</td><td>4.55</td><td>4.85</td></tr> <tr><td>00100</td><td>4.5</td><td>4.8</td></tr> <tr><td>00101</td><td>4.45</td><td>4.75</td></tr> <tr><td>00110</td><td>4.4</td><td></td></tr> <tr><td>00111</td><td>4.35</td><td></td></tr> <tr><td>01000</td><td>4.3</td><td></td></tr> <tr><td>01001</td><td>4.25</td><td></td></tr> <tr><td>01010</td><td>4.2</td><td></td></tr> <tr><td>01011</td><td>4.15</td><td></td></tr> <tr><td>01100</td><td>4.1</td><td></td></tr> <tr><td>01101</td><td>4.05</td><td></td></tr> <tr><td>01110</td><td>4</td><td></td></tr> <tr><td>01111</td><td>3.95</td><td></td></tr> <tr><td>10000</td><td>3.9</td><td></td></tr> <tr><td>10001</td><td>3.85</td><td></td></tr> <tr><td>10010</td><td>3.8</td><td></td></tr> <tr><td>10011</td><td>3.75</td><td></td></tr> <tr><td>10100</td><td>3.7</td><td></td></tr> <tr><td>10101</td><td>3.65</td><td></td></tr> <tr><td>10110</td><td>3.6</td><td></td></tr> <tr><td>10111</td><td>3.55</td><td></td></tr> <tr><td>11000</td><td>3.5</td><td></td></tr> <tr><td>11001</td><td>3.45</td><td></td></tr> <tr><td>11010</td><td>3.4</td><td></td></tr> <tr><td>11011</td><td>3.35</td><td></td></tr> <tr><td>11100</td><td>3.3</td><td></td></tr> <tr><td>11101</td><td>3.25</td><td></td></tr> <tr><td>11110</td><td>3.2</td><td></td></tr> <tr><td>11111</td><td>3.15</td><td></td></tr> </tbody> </table> | | VRHP[5] | 0 | 1 | VRHP[4:0] | GVDD | GVDD | 00000 | 4.7 | 5 | 00001 | 4.65 | 4.95 | 00010 | 4.6 | 4.9 | 00011 | 4.55 | 4.85 | 00100 | 4.5 | 4.8 | 00101 | 4.45 | 4.75 | 00110 | 4.4 | | 00111 | 4.35 | | 01000 | 4.3 | | 01001 | 4.25 | | 01010 | 4.2 | | 01011 | 4.15 | | 01100 | 4.1 | | 01101 | 4.05 | | 01110 | 4 | | 01111 | 3.95 | | 10000 | 3.9 | | 10001 | 3.85 | | 10010 | 3.8 | | 10011 | 3.75 | | 10100 | 3.7 | | 10101 | 3.65 | | 10110 | 3.6 | | 10111 | 3.55 | | 11000 | 3.5 | | 11001 | 3.45 | | 11010 | 3.4 | | 11011 | 3.35 | | 11100 | 3.3 | | 11101 | 3.25 | | 11110 | 3.2 | | 11111 | 3.15 | | <table border="1"> <thead> <tr> <th>VRHN[5]</th> <th>0</th> <th>1</th> </tr> </thead> <tbody> <tr> <th>VRHN[4:0]</th> <th>GVCL</th> <th>GVCL</th> </tr> <tr><td>00000</td><td>-4.7</td><td>-5</td></tr> <tr><td>00001</td><td>-4.65</td><td>-4.95</td></tr> <tr><td>00010</td><td>-4.6</td><td>-4.9</td></tr> <tr><td>00011</td><td>-4.55</td><td>-4.85</td></tr> <tr><td>00100</td><td>-4.5</td><td>-4.8</td></tr> <tr><td>00101</td><td>-4.45</td><td>-4.75</td></tr> <tr><td>00110</td><td>-4.4</td><td></td></tr> <tr><td>00111</td><td>-4.35</td><td></td></tr> <tr><td>01000</td><td>-4.3</td><td></td></tr> <tr><td>01001</td><td>-4.25</td><td></td></tr> <tr><td>01010</td><td>-4.2</td><td></td></tr> <tr><td>01011</td><td>-4.15</td><td></td></tr> <tr><td>01100</td><td>-4.1</td><td></td></tr> <tr><td>01101</td><td>-4.05</td><td></td></tr> <tr><td>01110</td><td>-4</td><td></td></tr> <tr><td>01111</td><td>-3.95</td><td></td></tr> <tr><td>10000</td><td>-3.9</td><td></td></tr> <tr><td>10001</td><td>-3.85</td><td></td></tr> <tr><td>10010</td><td>-3.8</td><td></td></tr> <tr><td>10011</td><td>-3.75</td><td></td></tr> <tr><td>10100</td><td>-3.7</td><td></td></tr> <tr><td>10101</td><td>-3.65</td><td></td></tr> <tr><td>10110</td><td>-3.6</td><td></td></tr> <tr><td>10111</td><td>-3.55</td><td></td></tr> <tr><td>11000</td><td>-3.5</td><td></td></tr> <tr><td>11001</td><td>-3.45</td><td></td></tr> <tr><td>11010</td><td>-3.4</td><td></td></tr> <tr><td>11011</td><td>-3.35</td><td></td></tr> <tr><td>11100</td><td>-3.3</td><td></td></tr> <tr><td>11101</td><td>-3.25</td><td></td></tr> <tr><td>11110</td><td>-3.2</td><td></td></tr> <tr><td>11111</td><td>-3.15</td><td></td></tr> </tbody> </table> | | VRHN[5] | 0 | 1 | VRHN[4:0] | GVCL | GVCL | 00000 | -4.7 | -5 | 00001 | -4.65 | -4.95 | 00010 | -4.6 | -4.9 | 00011 | -4.55 | -4.85 | 00100 | -4.5 | -4.8 | 00101 | -4.45 | -4.75 | 00110 | -4.4 | | 00111 | -4.35 | | 01000 | -4.3 | | 01001 | -4.25 | | 01010 | -4.2 | | 01011 | -4.15 | | 01100 | -4.1 | | 01101 | -4.05 | | 01110 | -4 | | 01111 | -3.95 | | 10000 | -3.9 | | 10001 | -3.85 | | 10010 | -3.8 | | 10011 | -3.75 | | 10100 | -3.7 | | 10101 | -3.65 | | 10110 | -3.6 | | 10111 | -3.55 | | 11000 | -3.5 | | 11001 | -3.45 | | 11010 | -3.4 | | 11011 | -3.35 | | 11100 | -3.3 | | 11101 | -3.25 | | 11110 | -3.2 | | 11111 | -3.15 | |
| | VRHP[5] | 0 | 1 | | | | | | | | | | | | | | | | | | | | | | | | | | | | | | | | | | | | | | | | | | | | | | | | | | | | | | | | | | | | | | | | | | | | | | | | | | | | | | | | | | | | | | | | | | | | | | | | | | | | | | | | | | | | | | | | | | | | | | | | | | | | | | | | | | | | | | | | | | | | | | | | | | | | | | | | | | | | | | | | | | | | | | | | | | | | | | | | | | | | | | | | | | | | | | | | | | | | | | | | | | | | | | | |
| | VRHP[4:0] | GVDD | GVDD | | | | | | | | | | | | | | | | | | | | | | | | | | | | | | | | | | | | | | | | | | | | | | | | | | | | | | | | | | | | | | | | | | | | | | | | | | | | | | | | | | | | | | | | | | | | | | | | | | | | | | | | | | | | | | | | | | | | | | | | | | | | | | | | | | | | | | | | | | | | | | | | | | | | | | | | | | | | | | | | | | | | | | | | | | | | | | | | | | | | | | | | | | | | | | | | | | | | | | | | | | | | | | | |
| | 00000 | 4.7 | 5 | | | | | | | | | | | | | | | | | | | | | | | | | | | | | | | | | | | | | | | | | | | | | | | | | | | | | | | | | | | | | | | | | | | | | | | | | | | | | | | | | | | | | | | | | | | | | | | | | | | | | | | | | | | | | | | | | | | | | | | | | | | | | | | | | | | | | | | | | | | | | | | | | | | | | | | | | | | | | | | | | | | | | | | | | | | | | | | | | | | | | | | | | | | | | | | | | | | | | | | | | | | | | | | |
| | 00001 | 4.65 | 4.95 | | | | | | | | | | | | | | | | | | | | | | | | | | | | | | | | | | | | | | | | | | | | | | | | | | | | | | | | | | | | | | | | | | | | | | | | | | | | | | | | | | | | | | | | | | | | | | | | | | | | | | | | | | | | | | | | | | | | | | | | | | | | | | | | | | | | | | | | | | | | | | | | | | | | | | | | | | | | | | | | | | | | | | | | | | | | | | | | | | | | | | | | | | | | | | | | | | | | | | | | | | | | | | | |
| | 00010 | 4.6 | 4.9 | | | | | | | | | | | | | | | | | | | | | | | | | | | | | | | | | | | | | | | | | | | | | | | | | | | | | | | | | | | | | | | | | | | | | | | | | | | | | | | | | | | | | | | | | | | | | | | | | | | | | | | | | | | | | | | | | | | | | | | | | | | | | | | | | | | | | | | | | | | | | | | | | | | | | | | | | | | | | | | | | | | | | | | | | | | | | | | | | | | | | | | | | | | | | | | | | | | | | | | | | | | | | | | |
| | 00011 | 4.55 | 4.85 | | | | | | | | | | | | | | | | | | | | | | | | | | | | | | | | | | | | | | | | | | | | | | | | | | | | | | | | | | | | | | | | | | | | | | | | | | | | | | | | | | | | | | | | | | | | | | | | | | | | | | | | | | | | | | | | | | | | | | | | | | | | | | | | | | | | | | | | | | | | | | | | | | | | | | | | | | | | | | | | | | | | | | | | | | | | | | | | | | | | | | | | | | | | | | | | | | | | | | | | | | | | | | | |
| | 00100 | 4.5 | 4.8 | | | | | | | | | | | | | | | | | | | | | | | | | | | | | | | | | | | | | | | | | | | | | | | | | | | | | | | | | | | | | | | | | | | | | | | | | | | | | | | | | | | | | | | | | | | | | | | | | | | | | | | | | | | | | | | | | | | | | | | | | | | | | | | | | | | | | | | | | | | | | | | | | | | | | | | | | | | | | | | | | | | | | | | | | | | | | | | | | | | | | | | | | | | | | | | | | | | | | | | | | | | | | | | |
| | 00101 | 4.45 | 4.75 | | | | | | | | | | | | | | | | | | | | | | | | | | | | | | | | | | | | | | | | | | | | | | | | | | | | | | | | | | | | | | | | | | | | | | | | | | | | | | | | | | | | | | | | | | | | | | | | | | | | | | | | | | | | | | | | | | | | | | | | | | | | | | | | | | | | | | | | | | | | | | | | | | | | | | | | | | | | | | | | | | | | | | | | | | | | | | | | | | | | | | | | | | | | | | | | | | | | | | | | | | | | | | | |
| | 00110 | 4.4 | | | | | | | | | | | | | | | | | | | | | | | | | | | | | | | | | | | | | | | | | | | | | | | | | | | | | | | | | | | | | | | | | | | | | | | | | | | | | | | | | | | | | | | | | | | | | | | | | | | | | | | | | | | | | | | | | | | | | | | | | | | | | | | | | | | | | | | | | | | | | | | | | | | | | | | | | | | | | | | | | | | | | | | | | | | | | | | | | | | | | | | | | | | | | | | | | | | | | | | | | | | | | | | | |
| 00111 | 4.35 | | | | | | | | | | | | | | | | | | | | | | | | | | | | | | | | | | | | | | | | | | | | | | | | | | | | | | | | | | | | | | | | | | | | | | | | | | | | | | | | | | | | | | | | | | | | | | | | | | | | | | | | | | | | | | | | | | | | | | | | | | | | | | | | | | | | | | | | | | | | | | | | | | | | | | | | | | | | | | | | | | | | | | | | | | | | | | | | | | | | | | | | | | | | | | | | | | | | | | | | | | | | | | | | | |
| 01000 | 4.3 | | | | | | | | | | | | | | | | | | | | | | | | | | | | | | | | | | | | | | | | | | | | | | | | | | | | | | | | | | | | | | | | | | | | | | | | | | | | | | | | | | | | | | | | | | | | | | | | | | | | | | | | | | | | | | | | | | | | | | | | | | | | | | | | | | | | | | | | | | | | | | | | | | | | | | | | | | | | | | | | | | | | | | | | | | | | | | | | | | | | | | | | | | | | | | | | | | | | | | | | | | | | | | | | | |
| 01001 | 4.25 | | | | | | | | | | | | | | | | | | | | | | | | | | | | | | | | | | | | | | | | | | | | | | | | | | | | | | | | | | | | | | | | | | | | | | | | | | | | | | | | | | | | | | | | | | | | | | | | | | | | | | | | | | | | | | | | | | | | | | | | | | | | | | | | | | | | | | | | | | | | | | | | | | | | | | | | | | | | | | | | | | | | | | | | | | | | | | | | | | | | | | | | | | | | | | | | | | | | | | | | | | | | | | | | | |
| 01010 | 4.2 | | | | | | | | | | | | | | | | | | | | | | | | | | | | | | | | | | | | | | | | | | | | | | | | | | | | | | | | | | | | | | | | | | | | | | | | | | | | | | | | | | | | | | | | | | | | | | | | | | | | | | | | | | | | | | | | | | | | | | | | | | | | | | | | | | | | | | | | | | | | | | | | | | | | | | | | | | | | | | | | | | | | | | | | | | | | | | | | | | | | | | | | | | | | | | | | | | | | | | | | | | | | | | | | | |
| 01011 | 4.15 | | | | | | | | | | | | | | | | | | | | | | | | | | | | | | | | | | | | | | | | | | | | | | | | | | | | | | | | | | | | | | | | | | | | | | | | | | | | | | | | | | | | | | | | | | | | | | | | | | | | | | | | | | | | | | | | | | | | | | | | | | | | | | | | | | | | | | | | | | | | | | | | | | | | | | | | | | | | | | | | | | | | | | | | | | | | | | | | | | | | | | | | | | | | | | | | | | | | | | | | | | | | | | | | | |
| 01100 | 4.1 | | | | | | | | | | | | | | | | | | | | | | | | | | | | | | | | | | | | | | | | | | | | | | | | | | | | | | | | | | | | | | | | | | | | | | | | | | | | | | | | | | | | | | | | | | | | | | | | | | | | | | | | | | | | | | | | | | | | | | | | | | | | | | | | | | | | | | | | | | | | | | | | | | | | | | | | | | | | | | | | | | | | | | | | | | | | | | | | | | | | | | | | | | | | | | | | | | | | | | | | | | | | | | | | | |
| 01101 | 4.05 | | | | | | | | | | | | | | | | | | | | | | | | | | | | | | | | | | | | | | | | | | | | | | | | | | | | | | | | | | | | | | | | | | | | | | | | | | | | | | | | | | | | | | | | | | | | | | | | | | | | | | | | | | | | | | | | | | | | | | | | | | | | | | | | | | | | | | | | | | | | | | | | | | | | | | | | | | | | | | | | | | | | | | | | | | | | | | | | | | | | | | | | | | | | | | | | | | | | | | | | | | | | | | | | | |
| 01110 | 4 | | | | | | | | | | | | | | | | | | | | | | | | | | | | | | | | | | | | | | | | | | | | | | | | | | | | | | | | | | | | | | | | | | | | | | | | | | | | | | | | | | | | | | | | | | | | | | | | | | | | | | | | | | | | | | | | | | | | | | | | | | | | | | | | | | | | | | | | | | | | | | | | | | | | | | | | | | | | | | | | | | | | | | | | | | | | | | | | | | | | | | | | | | | | | | | | | | | | | | | | | | | | | | | | | |
| 01111 | 3.95 | | | | | | | | | | | | | | | | | | | | | | | | | | | | | | | | | | | | | | | | | | | | | | | | | | | | | | | | | | | | | | | | | | | | | | | | | | | | | | | | | | | | | | | | | | | | | | | | | | | | | | | | | | | | | | | | | | | | | | | | | | | | | | | | | | | | | | | | | | | | | | | | | | | | | | | | | | | | | | | | | | | | | | | | | | | | | | | | | | | | | | | | | | | | | | | | | | | | | | | | | | | | | | | | | |
| 10000 | 3.9 | | | | | | | | | | | | | | | | | | | | | | | | | | | | | | | | | | | | | | | | | | | | | | | | | | | | | | | | | | | | | | | | | | | | | | | | | | | | | | | | | | | | | | | | | | | | | | | | | | | | | | | | | | | | | | | | | | | | | | | | | | | | | | | | | | | | | | | | | | | | | | | | | | | | | | | | | | | | | | | | | | | | | | | | | | | | | | | | | | | | | | | | | | | | | | | | | | | | | | | | | | | | | | | | | |
| 10001 | 3.85 | | | | | | | | | | | | | | | | | | | | | | | | | | | | | | | | | | | | | | | | | | | | | | | | | | | | | | | | | | | | | | | | | | | | | | | | | | | | | | | | | | | | | | | | | | | | | | | | | | | | | | | | | | | | | | | | | | | | | | | | | | | | | | | | | | | | | | | | | | | | | | | | | | | | | | | | | | | | | | | | | | | | | | | | | | | | | | | | | | | | | | | | | | | | | | | | | | | | | | | | | | | | | | | | | |
| 10010 | 3.8 | | | | | | | | | | | | | | | | | | | | | | | | | | | | | | | | | | | | | | | | | | | | | | | | | | | | | | | | | | | | | | | | | | | | | | | | | | | | | | | | | | | | | | | | | | | | | | | | | | | | | | | | | | | | | | | | | | | | | | | | | | | | | | | | | | | | | | | | | | | | | | | | | | | | | | | | | | | | | | | | | | | | | | | | | | | | | | | | | | | | | | | | | | | | | | | | | | | | | | | | | | | | | | | | | |
| 10011 | 3.75 | | | | | | | | | | | | | | | | | | | | | | | | | | | | | | | | | | | | | | | | | | | | | | | | | | | | | | | | | | | | | | | | | | | | | | | | | | | | | | | | | | | | | | | | | | | | | | | | | | | | | | | | | | | | | | | | | | | | | | | | | | | | | | | | | | | | | | | | | | | | | | | | | | | | | | | | | | | | | | | | | | | | | | | | | | | | | | | | | | | | | | | | | | | | | | | | | | | | | | | | | | | | | | | | | |
| 10100 | 3.7 | | | | | | | | | | | | | | | | | | | | | | | | | | | | | | | | | | | | | | | | | | | | | | | | | | | | | | | | | | | | | | | | | | | | | | | | | | | | | | | | | | | | | | | | | | | | | | | | | | | | | | | | | | | | | | | | | | | | | | | | | | | | | | | | | | | | | | | | | | | | | | | | | | | | | | | | | | | | | | | | | | | | | | | | | | | | | | | | | | | | | | | | | | | | | | | | | | | | | | | | | | | | | | | | | |
| 10101 | 3.65 | | | | | | | | | | | | | | | | | | | | | | | | | | | | | | | | | | | | | | | | | | | | | | | | | | | | | | | | | | | | | | | | | | | | | | | | | | | | | | | | | | | | | | | | | | | | | | | | | | | | | | | | | | | | | | | | | | | | | | | | | | | | | | | | | | | | | | | | | | | | | | | | | | | | | | | | | | | | | | | | | | | | | | | | | | | | | | | | | | | | | | | | | | | | | | | | | | | | | | | | | | | | | | | | | |
| 10110 | 3.6 | | | | | | | | | | | | | | | | | | | | | | | | | | | | | | | | | | | | | | | | | | | | | | | | | | | | | | | | | | | | | | | | | | | | | | | | | | | | | | | | | | | | | | | | | | | | | | | | | | | | | | | | | | | | | | | | | | | | | | | | | | | | | | | | | | | | | | | | | | | | | | | | | | | | | | | | | | | | | | | | | | | | | | | | | | | | | | | | | | | | | | | | | | | | | | | | | | | | | | | | | | | | | | | | | |
| 10111 | 3.55 | | | | | | | | | | | | | | | | | | | | | | | | | | | | | | | | | | | | | | | | | | | | | | | | | | | | | | | | | | | | | | | | | | | | | | | | | | | | | | | | | | | | | | | | | | | | | | | | | | | | | | | | | | | | | | | | | | | | | | | | | | | | | | | | | | | | | | | | | | | | | | | | | | | | | | | | | | | | | | | | | | | | | | | | | | | | | | | | | | | | | | | | | | | | | | | | | | | | | | | | | | | | | | | | | |
| 11000 | 3.5 | | | | | | | | | | | | | | | | | | | | | | | | | | | | | | | | | | | | | | | | | | | | | | | | | | | | | | | | | | | | | | | | | | | | | | | | | | | | | | | | | | | | | | | | | | | | | | | | | | | | | | | | | | | | | | | | | | | | | | | | | | | | | | | | | | | | | | | | | | | | | | | | | | | | | | | | | | | | | | | | | | | | | | | | | | | | | | | | | | | | | | | | | | | | | | | | | | | | | | | | | | | | | | | | | |
| 11001 | 3.45 | | | | | | | | | | | | | | | | | | | | | | | | | | | | | | | | | | | | | | | | | | | | | | | | | | | | | | | | | | | | | | | | | | | | | | | | | | | | | | | | | | | | | | | | | | | | | | | | | | | | | | | | | | | | | | | | | | | | | | | | | | | | | | | | | | | | | | | | | | | | | | | | | | | | | | | | | | | | | | | | | | | | | | | | | | | | | | | | | | | | | | | | | | | | | | | | | | | | | | | | | | | | | | | | | |
| 11010 | 3.4 | | | | | | | | | | | | | | | | | | | | | | | | | | | | | | | | | | | | | | | | | | | | | | | | | | | | | | | | | | | | | | | | | | | | | | | | | | | | | | | | | | | | | | | | | | | | | | | | | | | | | | | | | | | | | | | | | | | | | | | | | | | | | | | | | | | | | | | | | | | | | | | | | | | | | | | | | | | | | | | | | | | | | | | | | | | | | | | | | | | | | | | | | | | | | | | | | | | | | | | | | | | | | | | | | |
| 11011 | 3.35 | | | | | | | | | | | | | | | | | | | | | | | | | | | | | | | | | | | | | | | | | | | | | | | | | | | | | | | | | | | | | | | | | | | | | | | | | | | | | | | | | | | | | | | | | | | | | | | | | | | | | | | | | | | | | | | | | | | | | | | | | | | | | | | | | | | | | | | | | | | | | | | | | | | | | | | | | | | | | | | | | | | | | | | | | | | | | | | | | | | | | | | | | | | | | | | | | | | | | | | | | | | | | | | | | |
| 11100 | 3.3 | | | | | | | | | | | | | | | | | | | | | | | | | | | | | | | | | | | | | | | | | | | | | | | | | | | | | | | | | | | | | | | | | | | | | | | | | | | | | | | | | | | | | | | | | | | | | | | | | | | | | | | | | | | | | | | | | | | | | | | | | | | | | | | | | | | | | | | | | | | | | | | | | | | | | | | | | | | | | | | | | | | | | | | | | | | | | | | | | | | | | | | | | | | | | | | | | | | | | | | | | | | | | | | | | |
| 11101 | 3.25 | | | | | | | | | | | | | | | | | | | | | | | | | | | | | | | | | | | | | | | | | | | | | | | | | | | | | | | | | | | | | | | | | | | | | | | | | | | | | | | | | | | | | | | | | | | | | | | | | | | | | | | | | | | | | | | | | | | | | | | | | | | | | | | | | | | | | | | | | | | | | | | | | | | | | | | | | | | | | | | | | | | | | | | | | | | | | | | | | | | | | | | | | | | | | | | | | | | | | | | | | | | | | | | | | |
| 11110 | 3.2 | | | | | | | | | | | | | | | | | | | | | | | | | | | | | | | | | | | | | | | | | | | | | | | | | | | | | | | | | | | | | | | | | | | | | | | | | | | | | | | | | | | | | | | | | | | | | | | | | | | | | | | | | | | | | | | | | | | | | | | | | | | | | | | | | | | | | | | | | | | | | | | | | | | | | | | | | | | | | | | | | | | | | | | | | | | | | | | | | | | | | | | | | | | | | | | | | | | | | | | | | | | | | | | | | |
| 11111 | 3.15 | | | | | | | | | | | | | | | | | | | | | | | | | | | | | | | | | | | | | | | | | | | | | | | | | | | | | | | | | | | | | | | | | | | | | | | | | | | | | | | | | | | | | | | | | | | | | | | | | | | | | | | | | | | | | | | | | | | | | | | | | | | | | | | | | | | | | | | | | | | | | | | | | | | | | | | | | | | | | | | | | | | | | | | | | | | | | | | | | | | | | | | | | | | | | | | | | | | | | | | | | | | | | | | | | |
| VRHN[5] | 0 | 1 | | | | | | | | | | | | | | | | | | | | | | | | | | | | | | | | | | | | | | | | | | | | | | | | | | | | | | | | | | | | | | | | | | | | | | | | | | | | | | | | | | | | | | | | | | | | | | | | | | | | | | | | | | | | | | | | | | | | | | | | | | | | | | | | | | | | | | | | | | | | | | | | | | | | | | | | | | | | | | | | | | | | | | | | | | | | | | | | | | | | | | | | | | | | | | | | | | | | | | | | | | | | | | | | |
| VRHN[4:0] | GVCL | GVCL | | | | | | | | | | | | | | | | | | | | | | | | | | | | | | | | | | | | | | | | | | | | | | | | | | | | | | | | | | | | | | | | | | | | | | | | | | | | | | | | | | | | | | | | | | | | | | | | | | | | | | | | | | | | | | | | | | | | | | | | | | | | | | | | | | | | | | | | | | | | | | | | | | | | | | | | | | | | | | | | | | | | | | | | | | | | | | | | | | | | | | | | | | | | | | | | | | | | | | | | | | | | | | | | |
| 00000 | -4.7 | -5 | | | | | | | | | | | | | | | | | | | | | | | | | | | | | | | | | | | | | | | | | | | | | | | | | | | | | | | | | | | | | | | | | | | | | | | | | | | | | | | | | | | | | | | | | | | | | | | | | | | | | | | | | | | | | | | | | | | | | | | | | | | | | | | | | | | | | | | | | | | | | | | | | | | | | | | | | | | | | | | | | | | | | | | | | | | | | | | | | | | | | | | | | | | | | | | | | | | | | | | | | | | | | | | | |
| 00001 | -4.65 | -4.95 | | | | | | | | | | | | | | | | | | | | | | | | | | | | | | | | | | | | | | | | | | | | | | | | | | | | | | | | | | | | | | | | | | | | | | | | | | | | | | | | | | | | | | | | | | | | | | | | | | | | | | | | | | | | | | | | | | | | | | | | | | | | | | | | | | | | | | | | | | | | | | | | | | | | | | | | | | | | | | | | | | | | | | | | | | | | | | | | | | | | | | | | | | | | | | | | | | | | | | | | | | | | | | | | |
| 00010 | -4.6 | -4.9 | | | | | | | | | | | | | | | | | | | | | | | | | | | | | | | | | | | | | | | | | | | | | | | | | | | | | | | | | | | | | | | | | | | | | | | | | | | | | | | | | | | | | | | | | | | | | | | | | | | | | | | | | | | | | | | | | | | | | | | | | | | | | | | | | | | | | | | | | | | | | | | | | | | | | | | | | | | | | | | | | | | | | | | | | | | | | | | | | | | | | | | | | | | | | | | | | | | | | | | | | | | | | | | | |
| 00011 | -4.55 | -4.85 | | | | | | | | | | | | | | | | | | | | | | | | | | | | | | | | | | | | | | | | | | | | | | | | | | | | | | | | | | | | | | | | | | | | | | | | | | | | | | | | | | | | | | | | | | | | | | | | | | | | | | | | | | | | | | | | | | | | | | | | | | | | | | | | | | | | | | | | | | | | | | | | | | | | | | | | | | | | | | | | | | | | | | | | | | | | | | | | | | | | | | | | | | | | | | | | | | | | | | | | | | | | | | | | |
| 00100 | -4.5 | -4.8 | | | | | | | | | | | | | | | | | | | | | | | | | | | | | | | | | | | | | | | | | | | | | | | | | | | | | | | | | | | | | | | | | | | | | | | | | | | | | | | | | | | | | | | | | | | | | | | | | | | | | | | | | | | | | | | | | | | | | | | | | | | | | | | | | | | | | | | | | | | | | | | | | | | | | | | | | | | | | | | | | | | | | | | | | | | | | | | | | | | | | | | | | | | | | | | | | | | | | | | | | | | | | | | | |
| 00101 | -4.45 | -4.75 | | | | | | | | | | | | | | | | | | | | | | | | | | | | | | | | | | | | | | | | | | | | | | | | | | | | | | | | | | | | | | | | | | | | | | | | | | | | | | | | | | | | | | | | | | | | | | | | | | | | | | | | | | | | | | | | | | | | | | | | | | | | | | | | | | | | | | | | | | | | | | | | | | | | | | | | | | | | | | | | | | | | | | | | | | | | | | | | | | | | | | | | | | | | | | | | | | | | | | | | | | | | | | | | |
| 00110 | -4.4 | | | | | | | | | | | | | | | | | | | | | | | | | | | | | | | | | | | | | | | | | | | | | | | | | | | | | | | | | | | | | | | | | | | | | | | | | | | | | | | | | | | | | | | | | | | | | | | | | | | | | | | | | | | | | | | | | | | | | | | | | | | | | | | | | | | | | | | | | | | | | | | | | | | | | | | | | | | | | | | | | | | | | | | | | | | | | | | | | | | | | | | | | | | | | | | | | | | | | | | | | | | | | | | | | |
| 00111 | -4.35 | | | | | | | | | | | | | | | | | | | | | | | | | | | | | | | | | | | | | | | | | | | | | | | | | | | | | | | | | | | | | | | | | | | | | | | | | | | | | | | | | | | | | | | | | | | | | | | | | | | | | | | | | | | | | | | | | | | | | | | | | | | | | | | | | | | | | | | | | | | | | | | | | | | | | | | | | | | | | | | | | | | | | | | | | | | | | | | | | | | | | | | | | | | | | | | | | | | | | | | | | | | | | | | | | |
| 01000 | -4.3 | | | | | | | | | | | | | | | | | | | | | | | | | | | | | | | | | | | | | | | | | | | | | | | | | | | | | | | | | | | | | | | | | | | | | | | | | | | | | | | | | | | | | | | | | | | | | | | | | | | | | | | | | | | | | | | | | | | | | | | | | | | | | | | | | | | | | | | | | | | | | | | | | | | | | | | | | | | | | | | | | | | | | | | | | | | | | | | | | | | | | | | | | | | | | | | | | | | | | | | | | | | | | | | | | |
| 01001 | -4.25 | | | | | | | | | | | | | | | | | | | | | | | | | | | | | | | | | | | | | | | | | | | | | | | | | | | | | | | | | | | | | | | | | | | | | | | | | | | | | | | | | | | | | | | | | | | | | | | | | | | | | | | | | | | | | | | | | | | | | | | | | | | | | | | | | | | | | | | | | | | | | | | | | | | | | | | | | | | | | | | | | | | | | | | | | | | | | | | | | | | | | | | | | | | | | | | | | | | | | | | | | | | | | | | | | |
| 01010 | -4.2 | | | | | | | | | | | | | | | | | | | | | | | | | | | | | | | | | | | | | | | | | | | | | | | | | | | | | | | | | | | | | | | | | | | | | | | | | | | | | | | | | | | | | | | | | | | | | | | | | | | | | | | | | | | | | | | | | | | | | | | | | | | | | | | | | | | | | | | | | | | | | | | | | | | | | | | | | | | | | | | | | | | | | | | | | | | | | | | | | | | | | | | | | | | | | | | | | | | | | | | | | | | | | | | | | |
| 01011 | -4.15 | | | | | | | | | | | | | | | | | | | | | | | | | | | | | | | | | | | | | | | | | | | | | | | | | | | | | | | | | | | | | | | | | | | | | | | | | | | | | | | | | | | | | | | | | | | | | | | | | | | | | | | | | | | | | | | | | | | | | | | | | | | | | | | | | | | | | | | | | | | | | | | | | | | | | | | | | | | | | | | | | | | | | | | | | | | | | | | | | | | | | | | | | | | | | | | | | | | | | | | | | | | | | | | | | |
| 01100 | -4.1 | | | | | | | | | | | | | | | | | | | | | | | | | | | | | | | | | | | | | | | | | | | | | | | | | | | | | | | | | | | | | | | | | | | | | | | | | | | | | | | | | | | | | | | | | | | | | | | | | | | | | | | | | | | | | | | | | | | | | | | | | | | | | | | | | | | | | | | | | | | | | | | | | | | | | | | | | | | | | | | | | | | | | | | | | | | | | | | | | | | | | | | | | | | | | | | | | | | | | | | | | | | | | | | | | |
| 01101 | -4.05 | | | | | | | | | | | | | | | | | | | | | | | | | | | | | | | | | | | | | | | | | | | | | | | | | | | | | | | | | | | | | | | | | | | | | | | | | | | | | | | | | | | | | | | | | | | | | | | | | | | | | | | | | | | | | | | | | | | | | | | | | | | | | | | | | | | | | | | | | | | | | | | | | | | | | | | | | | | | | | | | | | | | | | | | | | | | | | | | | | | | | | | | | | | | | | | | | | | | | | | | | | | | | | | | | |
| 01110 | -4 | | | | | | | | | | | | | | | | | | | | | | | | | | | | | | | | | | | | | | | | | | | | | | | | | | | | | | | | | | | | | | | | | | | | | | | | | | | | | | | | | | | | | | | | | | | | | | | | | | | | | | | | | | | | | | | | | | | | | | | | | | | | | | | | | | | | | | | | | | | | | | | | | | | | | | | | | | | | | | | | | | | | | | | | | | | | | | | | | | | | | | | | | | | | | | | | | | | | | | | | | | | | | | | | | |
| 01111 | -3.95 | | | | | | | | | | | | | | | | | | | | | | | | | | | | | | | | | | | | | | | | | | | | | | | | | | | | | | | | | | | | | | | | | | | | | | | | | | | | | | | | | | | | | | | | | | | | | | | | | | | | | | | | | | | | | | | | | | | | | | | | | | | | | | | | | | | | | | | | | | | | | | | | | | | | | | | | | | | | | | | | | | | | | | | | | | | | | | | | | | | | | | | | | | | | | | | | | | | | | | | | | | | | | | | | | |
| 10000 | -3.9 | | | | | | | | | | | | | | | | | | | | | | | | | | | | | | | | | | | | | | | | | | | | | | | | | | | | | | | | | | | | | | | | | | | | | | | | | | | | | | | | | | | | | | | | | | | | | | | | | | | | | | | | | | | | | | | | | | | | | | | | | | | | | | | | | | | | | | | | | | | | | | | | | | | | | | | | | | | | | | | | | | | | | | | | | | | | | | | | | | | | | | | | | | | | | | | | | | | | | | | | | | | | | | | | | |
| 10001 | -3.85 | | | | | | | | | | | | | | | | | | | | | | | | | | | | | | | | | | | | | | | | | | | | | | | | | | | | | | | | | | | | | | | | | | | | | | | | | | | | | | | | | | | | | | | | | | | | | | | | | | | | | | | | | | | | | | | | | | | | | | | | | | | | | | | | | | | | | | | | | | | | | | | | | | | | | | | | | | | | | | | | | | | | | | | | | | | | | | | | | | | | | | | | | | | | | | | | | | | | | | | | | | | | | | | | | |
| 10010 | -3.8 | | | | | | | | | | | | | | | | | | | | | | | | | | | | | | | | | | | | | | | | | | | | | | | | | | | | | | | | | | | | | | | | | | | | | | | | | | | | | | | | | | | | | | | | | | | | | | | | | | | | | | | | | | | | | | | | | | | | | | | | | | | | | | | | | | | | | | | | | | | | | | | | | | | | | | | | | | | | | | | | | | | | | | | | | | | | | | | | | | | | | | | | | | | | | | | | | | | | | | | | | | | | | | | | | |
| 10011 | -3.75 | | | | | | | | | | | | | | | | | | | | | | | | | | | | | | | | | | | | | | | | | | | | | | | | | | | | | | | | | | | | | | | | | | | | | | | | | | | | | | | | | | | | | | | | | | | | | | | | | | | | | | | | | | | | | | | | | | | | | | | | | | | | | | | | | | | | | | | | | | | | | | | | | | | | | | | | | | | | | | | | | | | | | | | | | | | | | | | | | | | | | | | | | | | | | | | | | | | | | | | | | | | | | | | | | |
| 10100 | -3.7 | | | | | | | | | | | | | | | | | | | | | | | | | | | | | | | | | | | | | | | | | | | | | | | | | | | | | | | | | | | | | | | | | | | | | | | | | | | | | | | | | | | | | | | | | | | | | | | | | | | | | | | | | | | | | | | | | | | | | | | | | | | | | | | | | | | | | | | | | | | | | | | | | | | | | | | | | | | | | | | | | | | | | | | | | | | | | | | | | | | | | | | | | | | | | | | | | | | | | | | | | | | | | | | | | |
| 10101 | -3.65 | | | | | | | | | | | | | | | | | | | | | | | | | | | | | | | | | | | | | | | | | | | | | | | | | | | | | | | | | | | | | | | | | | | | | | | | | | | | | | | | | | | | | | | | | | | | | | | | | | | | | | | | | | | | | | | | | | | | | | | | | | | | | | | | | | | | | | | | | | | | | | | | | | | | | | | | | | | | | | | | | | | | | | | | | | | | | | | | | | | | | | | | | | | | | | | | | | | | | | | | | | | | | | | | | |
| 10110 | -3.6 | | | | | | | | | | | | | | | | | | | | | | | | | | | | | | | | | | | | | | | | | | | | | | | | | | | | | | | | | | | | | | | | | | | | | | | | | | | | | | | | | | | | | | | | | | | | | | | | | | | | | | | | | | | | | | | | | | | | | | | | | | | | | | | | | | | | | | | | | | | | | | | | | | | | | | | | | | | | | | | | | | | | | | | | | | | | | | | | | | | | | | | | | | | | | | | | | | | | | | | | | | | | | | | | | |
| 10111 | -3.55 | | | | | | | | | | | | | | | | | | | | | | | | | | | | | | | | | | | | | | | | | | | | | | | | | | | | | | | | | | | | | | | | | | | | | | | | | | | | | | | | | | | | | | | | | | | | | | | | | | | | | | | | | | | | | | | | | | | | | | | | | | | | | | | | | | | | | | | | | | | | | | | | | | | | | | | | | | | | | | | | | | | | | | | | | | | | | | | | | | | | | | | | | | | | | | | | | | | | | | | | | | | | | | | | | |
| 11000 | -3.5 | | | | | | | | | | | | | | | | | | | | | | | | | | | | | | | | | | | | | | | | | | | | | | | | | | | | | | | | | | | | | | | | | | | | | | | | | | | | | | | | | | | | | | | | | | | | | | | | | | | | | | | | | | | | | | | | | | | | | | | | | | | | | | | | | | | | | | | | | | | | | | | | | | | | | | | | | | | | | | | | | | | | | | | | | | | | | | | | | | | | | | | | | | | | | | | | | | | | | | | | | | | | | | | | | |
| 11001 | -3.45 | | | | | | | | | | | | | | | | | | | | | | | | | | | | | | | | | | | | | | | | | | | | | | | | | | | | | | | | | | | | | | | | | | | | | | | | | | | | | | | | | | | | | | | | | | | | | | | | | | | | | | | | | | | | | | | | | | | | | | | | | | | | | | | | | | | | | | | | | | | | | | | | | | | | | | | | | | | | | | | | | | | | | | | | | | | | | | | | | | | | | | | | | | | | | | | | | | | | | | | | | | | | | | | | | |
| 11010 | -3.4 | | | | | | | | | | | | | | | | | | | | | | | | | | | | | | | | | | | | | | | | | | | | | | | | | | | | | | | | | | | | | | | | | | | | | | | | | | | | | | | | | | | | | | | | | | | | | | | | | | | | | | | | | | | | | | | | | | | | | | | | | | | | | | | | | | | | | | | | | | | | | | | | | | | | | | | | | | | | | | | | | | | | | | | | | | | | | | | | | | | | | | | | | | | | | | | | | | | | | | | | | | | | | | | | | |
| 11011 | -3.35 | | | | | | | | | | | | | | | | | | | | | | | | | | | | | | | | | | | | | | | | | | | | | | | | | | | | | | | | | | | | | | | | | | | | | | | | | | | | | | | | | | | | | | | | | | | | | | | | | | | | | | | | | | | | | | | | | | | | | | | | | | | | | | | | | | | | | | | | | | | | | | | | | | | | | | | | | | | | | | | | | | | | | | | | | | | | | | | | | | | | | | | | | | | | | | | | | | | | | | | | | | | | | | | | | |
| 11100 | -3.3 | | | | | | | | | | | | | | | | | | | | | | | | | | | | | | | | | | | | | | | | | | | | | | | | | | | | | | | | | | | | | | | | | | | | | | | | | | | | | | | | | | | | | | | | | | | | | | | | | | | | | | | | | | | | | | | | | | | | | | | | | | | | | | | | | | | | | | | | | | | | | | | | | | | | | | | | | | | | | | | | | | | | | | | | | | | | | | | | | | | | | | | | | | | | | | | | | | | | | | | | | | | | | | | | | |
| 11101 | -3.25 | | | | | | | | | | | | | | | | | | | | | | | | | | | | | | | | | | | | | | | | | | | | | | | | | | | | | | | | | | | | | | | | | | | | | | | | | | | | | | | | | | | | | | | | | | | | | | | | | | | | | | | | | | | | | | | | | | | | | | | | | | | | | | | | | | | | | | | | | | | | | | | | | | | | | | | | | | | | | | | | | | | | | | | | | | | | | | | | | | | | | | | | | | | | | | | | | | | | | | | | | | | | | | | | | |
| 11110 | -3.2 | | | | | | | | | | | | | | | | | | | | | | | | | | | | | | | | | | | | | | | | | | | | | | | | | | | | | | | | | | | | | | | | | | | | | | | | | | | | | | | | | | | | | | | | | | | | | | | | | | | | | | | | | | | | | | | | | | | | | | | | | | | | | | | | | | | | | | | | | | | | | | | | | | | | | | | | | | | | | | | | | | | | | | | | | | | | | | | | | | | | | | | | | | | | | | | | | | | | | | | | | | | | | | | | | |
| 11111 | -3.15 | | | | | | | | | | | | | | | | | | | | | | | | | | | | | | | | | | | | | | | | | | | | | | | | | | | | | | | | | | | | | | | | | | | | | | | | | | | | | | | | | | | | | | | | | | | | | | | | | | | | | | | | | | | | | | | | | | | | | | | | | | | | | | | | | | | | | | | | | | | | | | | | | | | | | | | | | | | | | | | | | | | | | | | | | | | | | | | | | | | | | | | | | | | | | | | | | | | | | | | | | | | | | | | | | |

| | | | | | |
|-----------------------|---|----------|---------------|-----|--|
| Register Availability | Status | | Availability | | |
| | Normal Mode On, Idle Mode Off, Sleep Out | | Yes | | |
| | Normal Mode On, Idle Mode On, Sleep Out | | Yes | | |
| | Partial Mode On, Idle Mode Off, Sleep Out | | Yes | | |
| | Partial Mode On, Idle Mode On, Sleep Out | | Yes | | |
| | | Sleep In | | Yes | |
| Default | Status | | Default Value | | |
| | | | C0h | | |
| | Power On Sequence | | A8h/08h/84h | | |
| | S/W Reset | | A8h/08h/84h | | |
| | H/W Reset | | A8h/08h/84h | | |
| Flow Chart | <pre> graph TD PWCTR1[PWCTR1] --> Param[/1st Parameter 2nd parameter/] </pre> | | | | |
| | <p>Legend</p> <ul style="list-style-type: none"> Command Parameter Display Action Mode Sequential transfer | | | | |

10.2.6 PWCTR2 (C1h): Power Control 2

| C1H | PWCTR2 (Power Control 2) | | | | | | | | | | | | |
|---------------------------|---|-----|-----|-------|--|----------|---------------|----|-----------|-----------|----------|----------|-------|
| Inst / Para | D/CX | WRX | RDX | D17-8 | D7 | D6 | D5 | D4 | D3 | D2 | D1 | D0 | HEX |
| PWCTR2 | 0 | ↑ | 1 | - | 1 | 1 | 0 | 0 | 0 | 0 | 0 | 1 | (C1h) |
| 1 st parameter | 1 | ↑ | 1 | | VGH25[1] | VGH25[0] | - | - | VGLSEL[1] | VGLSEL[0] | VGHBT[1] | VGHBT[0] | |
| Description | -Set the VGH and VGL supply power level | | | | | | | | | | | | |
| | VGH25[1:0] | | | | V25 | | | | | | | | |
| | 00 | | | | 2.1 | | | | | | | | |
| | 01 | | | | 2.2 | | | | | | | | |
| | 10 | | | | 2.3 | | | | | | | | |
| | 11 | | | | 2.4 | | | | | | | | |
| | VGHBT[1:0] | | | | VGH | | | | | | | | |
| | 00 | | | | 2*AVDD+VGH25-0.5 | | | | | | | | |
| | 01 | | | | 3*AVDD-0.5 | | | | | | | | |
| | 10 | | | | 3*AVDD+VGH25-0.5 | | | | | | | | |
| | 11 | | | | Don't use this setting, reserve for testing. | | | | | | | | |
| | VGLSEL[1:0] | | | | VGL | | | | | | | | |
| | 00 | | | | -7.5 | | | | | | | | |
| | 01 | | | | -10 | | | | | | | | |
| | 10 | | | | -12.5 | | | | | | | | |
| 11 | | | | -13 | | | | | | | | | |
| Restriction | -The deviation value of VGH/ VGL between with Measurement and Specification: Max <= 1V -VGH-VGL <= 32V | | | | | | | | | | | | |
| Register Availability | Status | | | | | | Availability | | | | | | |
| | Normal Mode On, Idle Mode Off, Sleep Out | | | | | | Yes | | | | | | |
| | Normal Mode On, Idle Mode On, Sleep Out | | | | | | Yes | | | | | | |
| | Partial Mode On, Idle Mode Off, Sleep Out | | | | | | Yes | | | | | | |
| | Partial Mode On, Idle Mode On, Sleep Out | | | | | | Yes | | | | | | |
| Sleep In | | | | | | Yes | | | | | | | |
| Default | Status | | | | | | Default Value | | | | | | |
| | Power On Sequence | | | | | | C1h | | | | | | |
| | SW Reset | | | | | | C0h | | | | | | |
| | H/W Reset | | | | | | C0h | | | | | | |

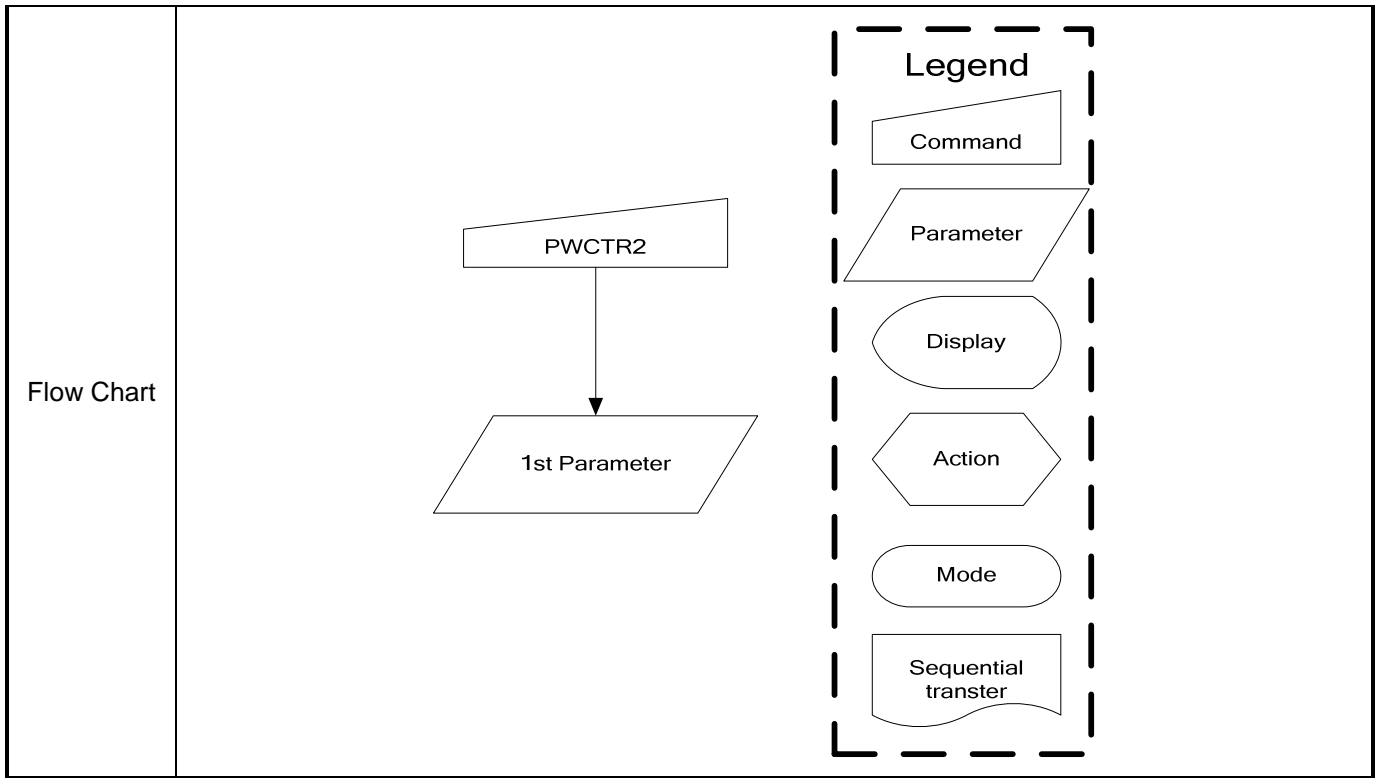

10.2.7 PWCTR3 (C2h): Power Control 3 (in Normal mode/ Full colors)

| C2H | PWCTR3 (Power Control 3) | | | | | | | | | | | | |
|---|--|--|--|----------|----------|----------|-------|-------|-------|------|------|------|-------|
| Inst / Para | D/CX | WRX | RDX | D17-8 | D7 | D6 | D5 | D4 | D3 | D2 | D1 | D0 | HEX |
| PWCTR3 | 0 | ↑ | 1 | - | 1 | 1 | 0 | 0 | 0 | 0 | 1 | 0 | (C2h) |
| 1 st | 1 | ↑ | 1 | - | DCA9 | DCA8 | SAPA2 | SAPA1 | SAPA0 | APA2 | APA1 | APA0 | |
| 2 nd | 1 | ↑ | 1 | - | DCA7 | DCA6 | DCA5 | DCA4 | DCA3 | DCA2 | DCA1 | DCA0 | |
| Description | -Set the amount of current in Operational amplifier in normal mode/full colors. -Adjust the amount of fixed current from the fixed current source in the operational amplifier for the source driver. | | | | | | | | | | | | |
| | AP[2:0] | | Amount of Current in Operational Amplifier | | | | | | | | | | |
| | 000 | | Operation of the operational amplifier stops | | | | | | | | | | |
| | 001 | | Small | | | | | | | | | | |
| | 010 | | Medium Low | | | | | | | | | | |
| | 011 | | Medium | | | | | | | | | | |
| | 100 | | Medium High | | | | | | | | | | |
| | 101 | | Large | | | | | | | | | | |
| | 110 | | Reserved | | | | | | | | | | |
| | 111 | | Reserved | | | | | | | | | | |
| SAP[2:0] | | Amount of Current in Operational Amplifier | | | | | | | | | | | |
| 000 | | Operation of the operational amplifier stops | | | | | | | | | | | |
| 001 | | Small | | | | | | | | | | | |
| 010 | | Medium Low | | | | | | | | | | | |
| 011 | | Medium | | | | | | | | | | | |
| 100 | | Medium High | | | | | | | | | | | |
| 101 | | Large | | | | | | | | | | | |
| 110 | | Reserved | | | | | | | | | | | |
| 111 | | Reserved | | | | | | | | | | | |
| -Set the Booster circuit Step-up cycle in Normal mode/ full colors. | | | | | | | | | | | | | |
| | | DCA[9:8] | DCA[7:6] | DCA[5:4] | DCA[3:2] | DCA[1:0] | | | | | | | |
| 00 | | BCLK/1 | BCLK/3 | BCLK/1 | BCLK/1 | BCLK/1 | | | | | | | |
| 01 | | BCLK/3 | BCLK/1 | BCLK/3 | BCLK/3 | BCLK/3 | | | | | | | |
| 10 | | BCLK/2 | BCLK/4 | BCLK/2 | BCLK/2 | BCLK/2 | | | | | | | |
| 11 | | BCLK/4 | BCLK/2 | BCLK/4 | BCLK/4 | BCLK/4 | | | | | | | |
| Note: BCLK is Clock frequency for Booster circuit | | | | | | | | | | | | | |

| Register Availability | <table border="1"> <thead> <tr> <th>Status</th> <th>Availability</th> </tr> </thead> <tbody> <tr> <td>Normal Mode On, Idle Mode Off, Sleep Out</td> <td>Yes</td> </tr> <tr> <td>Normal Mode On, Idle Mode On, Sleep Out</td> <td>Yes</td> </tr> <tr> <td>Partial Mode On, Idle Mode Off, Sleep Out</td> <td>Yes</td> </tr> <tr> <td>Partial Mode On, Idle Mode On, Sleep Out</td> <td>Yes</td> </tr> <tr> <td>Sleep In</td> <td>Yes</td> </tr> </tbody> </table> | | Status | Availability | Normal Mode On, Idle Mode Off, Sleep Out | Yes | Normal Mode On, Idle Mode On, Sleep Out | Yes | Partial Mode On, Idle Mode Off, Sleep Out | Yes | Partial Mode On, Idle Mode On, Sleep Out | Yes | Sleep In | Yes |
|--|--|---------------|--------|---------------|--|-------------------|---|-----------|---|-----------|--|-----|----------|-----|
| | Status | Availability | | | | | | | | | | | | |
| | Normal Mode On, Idle Mode Off, Sleep Out | Yes | | | | | | | | | | | | |
| | Normal Mode On, Idle Mode On, Sleep Out | Yes | | | | | | | | | | | | |
| | Partial Mode On, Idle Mode Off, Sleep Out | Yes | | | | | | | | | | | | |
| Partial Mode On, Idle Mode On, Sleep Out | Yes | | | | | | | | | | | | | |
| Sleep In | Yes | | | | | | | | | | | | | |
| Default | <table border="1"> <thead> <tr> <th rowspan="2">Status</th> <th>Default Value</th> </tr> </thead> <tbody> <tr> <td>C2h</td> </tr> <tr> <td>Power On Sequence</td> <td>0Ah/00h</td> </tr> <tr> <td>S/W Reset</td> <td>0A h/00h</td> </tr> <tr> <td>H/W Reset</td> <td>0A h/00h</td> </tr> </tbody> </table> | | Status | Default Value | C2h | Power On Sequence | 0Ah/00h | S/W Reset | 0A h/00h | H/W Reset | 0A h/00h | | | |
| | Status | Default Value | | | | | | | | | | | | |
| | | C2h | | | | | | | | | | | | |
| | Power On Sequence | 0Ah/00h | | | | | | | | | | | | |
| | S/W Reset | 0A h/00h | | | | | | | | | | | | |
| H/W Reset | 0A h/00h | | | | | | | | | | | | | |
| Flow Chart | <pre> graph TD PWCTR3[PWCTR3] --> Param[1st Parameter 2nd parameter] </pre> | | | | | | | | | | | | | |
| | <p>Legend</p> <ul style="list-style-type: none"> Command Parameter Display Action Mode Sequential transfer | | | | | | | | | | | | | |

10.2.8 PWCTR4 (C3h): Power Control 4 (in Idle mode/ 8-colors)

| C3H | PWCTR4 (Power Control 4) | | | | | | | | | | | | |
|---|---|-------------|--|----------|----------|----------|-------|-------|-------|------|------|------|-------|
| Inst / Para | D/CX | WRX | RDX | D17-8 | D7 | D6 | D5 | D4 | D3 | D2 | D1 | D0 | HEX |
| PWCTR4 | 0 | ↑ | 1 | - | 1 | 1 | 0 | 0 | 0 | 0 | 1 | 1 | (C3h) |
| 1 st parameter | 1 | ↑ | 1 | - | DCB9 | DCB8 | SAPB2 | SAPB1 | SAPB0 | APB2 | APB1 | APB0 | |
| 2 nd parameter | 1 | ↑ | 1 | - | DCB7 | DCB6 | DCB5 | DCB4 | DCB3 | DCB2 | DCB1 | DCB0 | |
| Description | -Set the amount of current in Operational amplifier in Idle mode/8 colors. -Adjust the amount of fixed current from the fixed current source in the operational amplifier for the source driver. | | | | | | | | | | | | |
| | AP[2:0] | | Amount of Current in Operational Amplifier | | | | | | | | | | |
| | 000 | | Operation of the operational amplifier stops | | | | | | | | | | |
| | 001 | | Small | | | | | | | | | | |
| | 010 | | Medium Low | | | | | | | | | | |
| | 011 | | Medium | | | | | | | | | | |
| | 100 | | Medium High | | | | | | | | | | |
| | 101 | | Large | | | | | | | | | | |
| | 110 | | Reserved | | | | | | | | | | |
| | 111 | | Reserved | | | | | | | | | | |
| | SAP[2:0] | | Amount of Current in Operational Amplifier | | | | | | | | | | |
| | 000 | | Operation of the operational amplifier stops | | | | | | | | | | |
| | 001 | | Small | | | | | | | | | | |
| | 010 | | Medium Low | | | | | | | | | | |
| | 011 | | Medium | | | | | | | | | | |
| 100 | | Medium High | | | | | | | | | | | |
| 101 | | Large | | | | | | | | | | | |
| 110 | | Reserved | | | | | | | | | | | |
| 111 | | Reserved | | | | | | | | | | | |
| -Set the Booster circuit Step-up cycle in Idle mode/8 colors. | | | | | | | | | | | | | |
| | | DCB[9:8] | DCB[7:6] | DCB[5:4] | DCB[3:2] | DCB[1:0] | | | | | | | |
| 00 | | BCLK/1 | BCLK/3 | BCLK/1 | BCLK/1 | BCLK/1 | | | | | | | |
| 01 | | BCLK/3 | BCLK/1 | BCLK/3 | BCLK/3 | BCLK/3 | | | | | | | |
| 10 | | BCLK/2 | BCLK/4 | BCLK/2 | BCLK/2 | BCLK/2 | | | | | | | |
| 11 | | BCLK/4 | BCLK/2 | BCLK/4 | BCLK/4 | BCLK/4 | | | | | | | |
| Note: BCLK is Clock frequency for Booster circuit | | | | | | | | | | | | | |

| | | | | | |
|-----------------------|---|----------|---------------|-----|--|
| Register Availability | Status | | Availability | | |
| | Normal Mode On, Idle Mode Off, Sleep Out | | Yes | | |
| | Normal Mode On, Idle Mode On, Sleep Out | | Yes | | |
| | Partial Mode On, Idle Mode Off, Sleep Out | | Yes | | |
| | Partial Mode On, Idle Mode On, Sleep Out | | Yes | | |
| | | Sleep In | | Yes | |
| Default | Status | | Default Value | | |
| | | | C3h | | |
| | Power On Sequence | | 8Ah/26h | | |
| | S/W Reset | | 8Ah/26h | | |
| | H/W Reset | | 8Ah/26h | | |
| Flow Chart | <pre> graph TD PWCTR4[PWCTR4] --> Param[/1st Parameter 2nd parameter/] </pre> | | | | |
| | <div style="border: 1px dashed black; padding: 5px;"> <p style="text-align: center;">Legend</p> <div style="display: flex; flex-direction: column; gap: 10px;"> <div style="border: 1px solid black; padding: 2px; width: 100px; height: 20px; margin-bottom: 5px;"></div> <div style="border: 1px solid black; padding: 2px; width: 100px; height: 20px; transform: rotate(-15deg); margin-bottom: 5px;"></div> <div style="border: 1px solid black; padding: 2px; width: 100px; height: 20px; border-radius: 10px; margin-bottom: 5px;"></div> <div style="border: 1px solid black; padding: 2px; width: 100px; height: 20px; margin-bottom: 5px;"></div> <div style="border: 1px solid black; padding: 2px; width: 100px; height: 20px; border-radius: 10px; margin-bottom: 5px;"></div> <div style="border: 1px solid black; padding: 2px; width: 100px; height: 20px; margin-bottom: 5px;"></div> </div> </div> | | | | |

10.2.9 PWCTR5 (C4h): Power Control 5 (in Partial mode/ full-colors)

| C4H | PWCTR5 (Power Control 5) | | | | | | | | | | | | |
|--|--|-------------|--|----------|----------|----------|-------|-------|-------|------|------|------|-------|
| Inst / Para | D/CX | WRX | RDX | D17-8 | D7 | D6 | D5 | D4 | D3 | D2 | D1 | D0 | HEX |
| PWCTR5 | 0 | ↑ | 1 | - | 1 | 1 | 0 | 0 | 0 | 1 | 0 | 0 | (C4h) |
| 1 st parameter | 1 | ↑ | 1 | - | DCC9 | DCC8 | SAPC2 | SAPC1 | SAPC0 | APC2 | APC1 | APC0 | |
| 2 nd parameter | 1 | ↑ | 1 | - | DCC7 | DCC6 | DCC5 | DCC4 | DCC3 | DCC2 | DCC1 | DCC0 | |
| Description | -Set the amount of current in Operational amplifier in Partial mode/ full-colors. -Adjust the amount of fixed current from the fixed current source in the operational amplifier for the source driver. | | | | | | | | | | | | |
| | AP[2:0] | | Amount of Current in Operational Amplifier | | | | | | | | | | |
| | 000 | | Operation of the operational amplifier stops | | | | | | | | | | |
| | 001 | | Small | | | | | | | | | | |
| | 010 | | Medium Low | | | | | | | | | | |
| | 011 | | Medium | | | | | | | | | | |
| | 100 | | Medium High | | | | | | | | | | |
| | 101 | | Large | | | | | | | | | | |
| | 110 | | Reserved | | | | | | | | | | |
| | 111 | | Reserved | | | | | | | | | | |
| | SAP[2:0] | | Amount of Current in Operational Amplifier | | | | | | | | | | |
| | 000 | | Operation of the operational amplifier stops | | | | | | | | | | |
| | 001 | | Small | | | | | | | | | | |
| | 010 | | Medium Low | | | | | | | | | | |
| | 011 | | Medium | | | | | | | | | | |
| 100 | | Medium High | | | | | | | | | | | |
| 101 | | Large | | | | | | | | | | | |
| 110 | | Reserved | | | | | | | | | | | |
| 111 | | Reserved | | | | | | | | | | | |
| -Set the Booster circuit Step-up cycle in Partial mode/ full-colors. | | | | | | | | | | | | | |
| | | DCC[9:8] | DCC[7:6] | DCC[5:4] | DCC[3:2] | DCC[1:0] | | | | | | | |
| | 00 | BCLK/1 | BCLK/3 | BCLK/1 | BCLK/1 | BCLK/1 | | | | | | | |
| | 01 | BCLK/3 | BCLK/1 | BCLK/3 | BCLK/3 | BCLK/3 | | | | | | | |
| | 10 | BCLK/2 | BCLK/4 | BCLK/2 | BCLK/2 | BCLK/2 | | | | | | | |
| | 11 | BCLK/4 | BCLK/2 | BCLK/4 | BCLK/4 | BCLK/4 | | | | | | | |
| Note: BCLK is Clock frequency for Booster circuit | | | | | | | | | | | | | |

| | | | | | |
|-----------------------|---|----------|---------------|-----|--|
| Register Availability | Status | | Availability | | |
| | Normal Mode On, Idle Mode Off, Sleep Out | | Yes | | |
| | Normal Mode On, Idle Mode On, Sleep Out | | Yes | | |
| | Partial Mode On, Idle Mode Off, Sleep Out | | Yes | | |
| | Partial Mode On, Idle Mode On, Sleep Out | | Yes | | |
| | | Sleep In | | Yes | |
| Default | Status | | Default Value | | |
| | | | C4h | | |
| | Power On Sequence | | 8Ah/Eeh | | |
| | S/W Reset | | 8Ah/Eeh | | |
| | H/W Reset | | 8Ah/Eeh | | |
| Flow Chart | <pre> graph TD PWCTR5[PWCTR5] --> Param[1st Parameter 2nd parameter] </pre> | | | | |
| | <div style="border: 1px dashed black; padding: 5px;"> <p style="text-align: center;">Legend</p> <div style="display: flex; flex-direction: column; gap: 10px;"> <div style="border: 1px solid black; width: 100px; height: 20px; margin-bottom: 5px;"></div> <div style="border: 1px solid black; width: 100px; height: 20px; transform: rotate(-15deg); margin-bottom: 5px;"></div> <div style="border: 1px solid black; width: 100px; height: 20px; border-radius: 10px; margin-bottom: 5px;"></div> <div style="border: 1px solid black; width: 100px; height: 20px; margin-bottom: 5px;"></div> <div style="border: 1px solid black; width: 100px; height: 20px; border-radius: 10px; margin-bottom: 5px;"></div> <div style="border: 1px solid black; width: 100px; height: 20px; margin-bottom: 5px;"></div> </div> </div> | | | | |

10.2.10 VMCTR1 (C5h): VCOM Control 1

| C5H | | VMCTR1 (VCOM Control 1) | | | | | | | | | | | |
|---------------------------|---|-------------------------|--------|--------|----------------|--------|---------------|----------------|------------|------------|----------------|------------|-------|
| Inst / Para | D/CX | WRX | RDX | D17-8 | D7 | D6 | D5 | D4 | D3 | D2 | D1 | D0 | HEX |
| VMCTR1 | 0 | ↑ | 1 | - | 1 | 1 | 0 | 0 | 0 | 1 | 0 | 1 | (C5h) |
| 1 st parameter | 1 | ↑ | 1 | - | - | - | VCOMS 5 | VCOMS 4 | VCOMS 3 | VCOMS 2 | VCOMS 1 | VCOMS 0 | |
| Description | VCOM voltage setting. | | | | | | | | | | | | |
| | | VCOMS [5:0] | VCOM | | VCOMS [5:0] | VCOM | | VCOMS [5:0] | VCOM | | VCOMS [5:0] | VCOM | |
| | 0 | 000000 | -0.425 | 16 | 010000 | -0.825 | 32 | 100000 | -1.225 | 48 | 110000 | -1.625 | |
| | 1 | 000001 | -0.45 | 17 | 010001 | -0.85 | 33 | 100001 | -1.25 | 49 | 110001 | -1.65 | |
| | 2 | 000010 | -0.475 | 18 | 010010 | -0.875 | 34 | 100010 | -1.275 | 50 | 110010 | -1.675 | |
| | 3 | 000011 | -0.5 | 19 | 010011 | -0.9 | 35 | 100011 | -1.3 | 51 | 110011 | -1.7 | |
| | 4 | 000100 | -0.525 | 20 | 010100 | -0.925 | 36 | 100100 | -1.325 | 52 | 110100 | -1.725 | |
| | 5 | 000101 | -0.55 | 21 | 010101 | -0.95 | 37 | 100101 | -1.35 | 53 | 110101 | -1.75 | |
| | 6 | 000110 | -0.575 | 22 | 010110 | -0.975 | 38 | 100110 | -1.375 | 54 | 110110 | -1.775 | |
| | 7 | 000111 | -0.6 | 23 | 010111 | -1 | 39 | 100111 | -1.4 | 55 | 110111 | -1.8 | |
| | 8 | 001000 | -0.625 | 24 | 011000 | -1.025 | 40 | 101000 | -1.425 | 56 | 111000 | -1.825 | |
| | 9 | 001001 | -0.65 | 25 | 011001 | -1.05 | 41 | 101001 | -1.45 | 57 | 111001 | -1.85 | |
| | 10 | 001010 | -0.675 | 26 | 011010 | -1.075 | 42 | 101010 | -1.475 | 58 | 111010 | -1.875 | |
| | 11 | 001011 | -0.7 | 27 | 011011 | -1.1 | 43 | 101011 | -1.5 | 59 | 111011 | -1.9 | |
| | 12 | 001100 | -0.725 | 28 | 011100 | -1.125 | 44 | 101100 | -1.525 | 60 | 111100 | -1.925 | |
| | 13 | 001101 | -0.75 | 29 | 011101 | -1.15 | 45 | 101101 | -1.55 | 61 | 111101 | -1.95 | |
| | 14 | 001110 | -0.775 | 30 | 011110 | -1.175 | 46 | 101110 | -1.575 | 62 | 111110 | -1.975 | |
| 15 | 001111 | -0.8 | 31 | 011111 | -1.2 | 47 | 101111 | -1.6 | 63 | 111111 | -2 | | |
| Register Availability | Status | | | | | | Availability | | | | | | |
| | Normal Mode On, Idle Mode Off, Sleep Out | | | | | | Yes | | | | | | |
| | Normal Mode On, Idle Mode On, Sleep Out | | | | | | Yes | | | | | | |
| | Partial Mode On, Idle Mode Off, Sleep Out | | | | | | Yes | | | | | | |
| | Partial Mode On, Idle Mode On, Sleep Out | | | | | | Yes | | | | | | |
| | Sleep In | | | | | | Yes | | | | | | |
| Default | Status | | | | | | Default Value | | | | | | |
| | | | | | | | C5h | | | | | | |
| | Power On Sequence | | | | | | 05h | | | | | | |
| | S/W Reset | | | | | | 05h | | | | | | |
| | H/W Reset | | | | | | 05h | | | | | | |

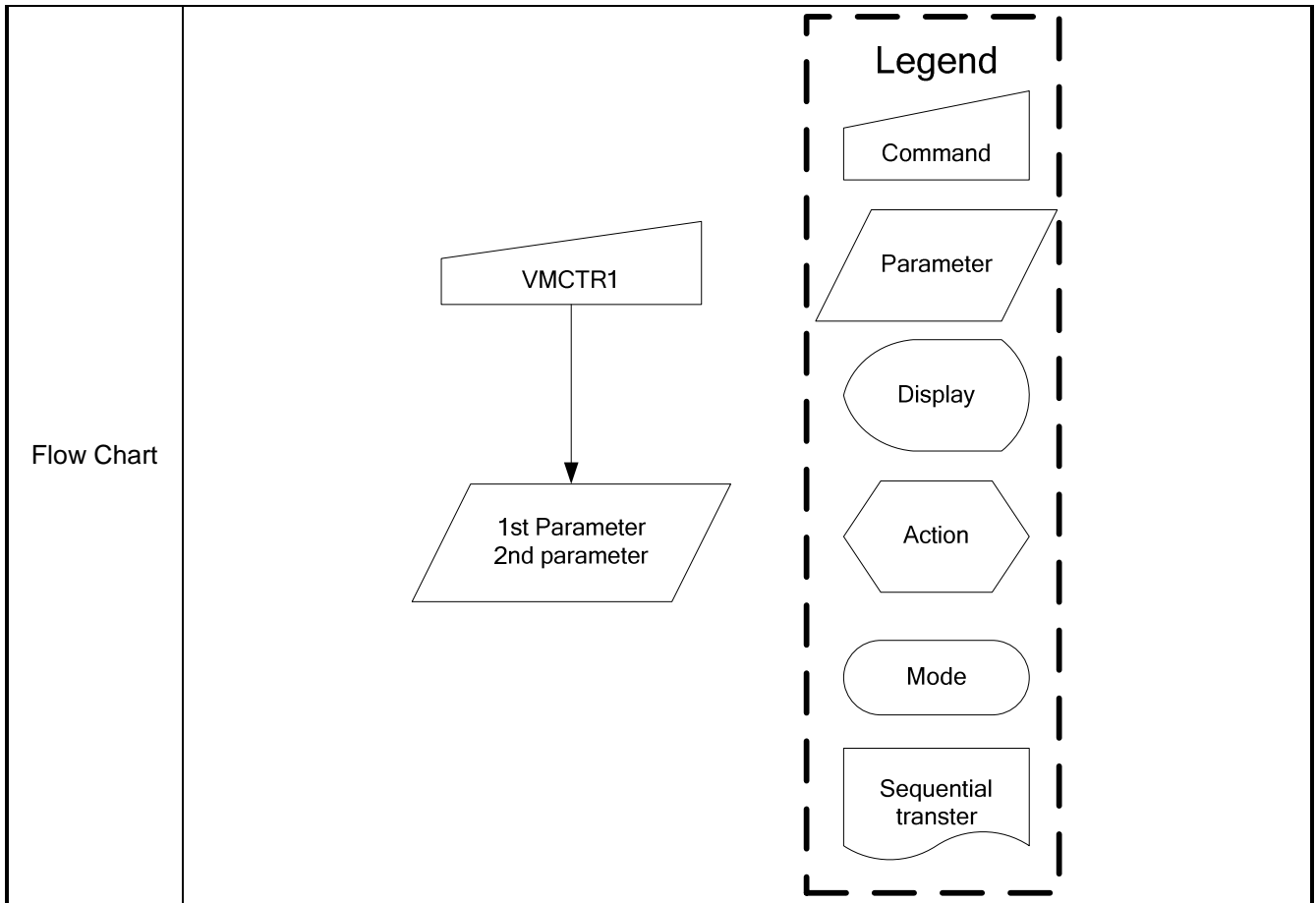

10.2.11 VMOFCTR (C7h): VCOM Offset Control

| C7H | | VMOFCTR (VCOM Offset Control) | | | | | | | | | | | |
|--------------------------------|--|-------------------------------|----------|-------|---------------|-------------------|----|------|--------------|------|------|------|-------|
| Inst / Para | D/CX | WRX | RDX | D17-8 | D7 | D6 | D5 | D4 | D3 | D2 | D1 | D0 | HEX |
| VMOFCTR | 0 | ↑ | 1 | - | 1 | 1 | 0 | 0 | 0 | 1 | 1 | 1 | (C7h) |
| Parameter | 1 | ↑ | 1 | - | - | - | - | VMF4 | VMF3 | VMF2 | VMF1 | VMF0 | |
| Description | -Set VCOM Voltage level for reduce the flicker issue -Before use command 0xC7, the bit VMF_EN of command 0xD9 must be enabled (set to 1). | | | | | | | | | | | | |
| | VMF[4] | | VMF[3:0] | | | VCOM Output Level | | | | | | | |
| | 0 | | 0000 | | | "VCOMS"+16d | | | | | | | |
| | 0 | | 0001 | | | "VCOMS"+15d | | | | | | | |
| | 0 | | | | | | | | | | | | |
| | 0 | | 1110 | | | "VCOMS"+2d | | | | | | | |
| | 0 | | 1111 | | | "VCOMS"+1d | | | | | | | |
| | 1 | | 0000 | | | "VCOMS" | | | | | | | |
| | 1 | | 0001 | | | "VCOMS"-1d | | | | | | | |
| | 1 | | 0010 | | | "VCOMS"-2d | | | | | | | |
| | 1 | | | | | | | | | | | | |
| | 1 | | 1110 | | | "VCOMS"-14d | | | | | | | |
| | 1 | | 1111 | | | "VCOMS"-15d | | | | | | | |
| - 1d=25mV, 2d=50mV 3d=75mv.... | | | | | | | | | | | | | |
| Register Availability | Status | | | | | | | | Availability | | | | |
| | Normal Mode On, Idle Mode Off, Sleep Out | | | | | | | | Yes | | | | |
| | Normal Mode On, Idle Mode On, Sleep Out | | | | | | | | Yes | | | | |
| | Partial Mode On, Idle Mode Off, Sleep Out | | | | | | | | Yes | | | | |
| | Partial Mode On, Idle Mode On, Sleep Out | | | | | | | | Yes | | | | |
| | Sleep In | | | | | | | | Yes | | | | |
| Default | Status | | | | Default Value | | | | | | | | |
| | | | | | C7h | | | | | | | | |
| | Power On Sequence | | | | 10h | | | | | | | | |
| | S/W Reset | | | | 10h | | | | | | | | |
| | H/W Reset | | | | 10h | | | | | | | | |

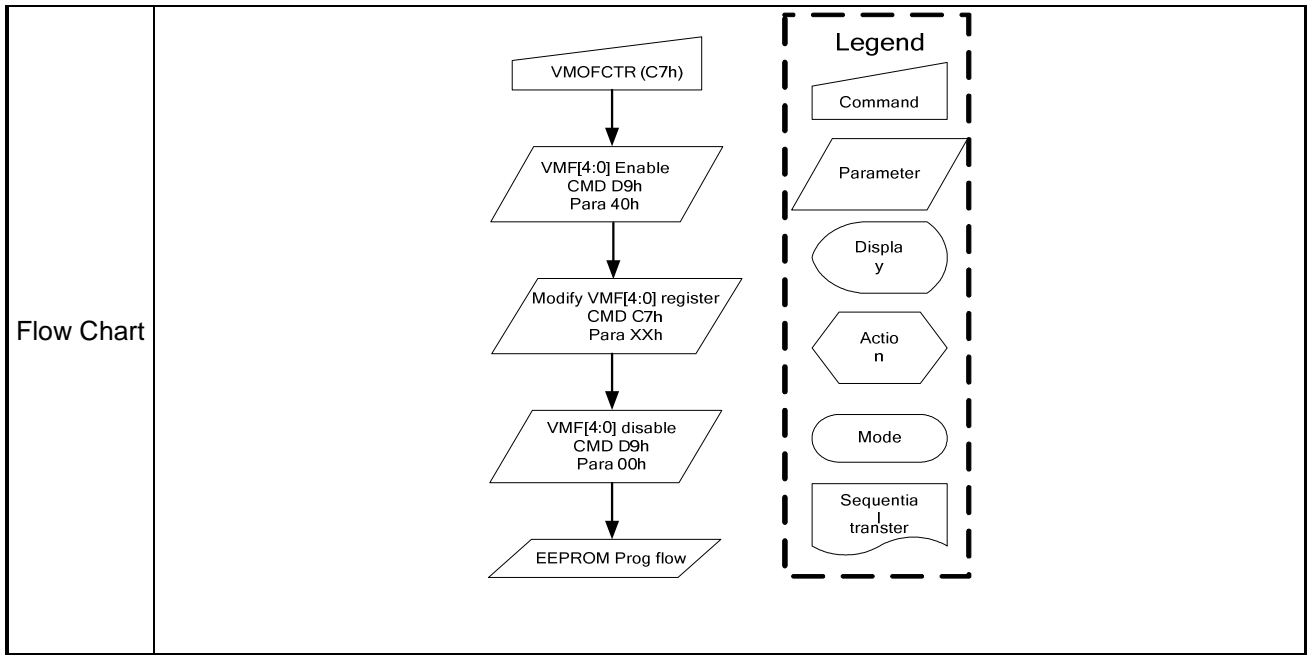

10.2.12 WRID2 (D1h): Write ID2 Value

| D1H | WRID2 (Write ID2 Value) | | | | | | | | | | | | |
|-------------|--|-----|-----|-------|----|------|------|------|------|------|------|------|-------|
| Inst / Para | D/CX | WRX | RDX | D17-8 | D7 | D6 | D5 | D4 | D3 | D2 | D1 | D0 | HEX |
| WRID2 | 0 | ↑ | 1 | - | 1 | 1 | 0 | 1 | 0 | 0 | 0 | 1 | (D1h) |
| Parameter | 1 | ↑ | 1 | - | - | ID26 | ID25 | ID24 | ID23 | ID22 | ID21 | ID20 | - |
| Description | -Write 7-bit data of LCD module version to save it to NVM. -The parameter ID2[6:0] is LCD Module version ID. | | | | | | | | | | | | |
| Flow Chart | <pre> graph TD A[NVCTR3 (D1h)] --> B[/ID2[6:0] Enable CMD D9h Para 10h/] B --> C[/Modify ID2[6:0] register CMD D1h Para XXh/] C --> D[/ID2[6:0] disable CMD D9h Para 00h/] D --> E[/EEPROM Prog flow/] </pre> <p>Legend</p> <ul style="list-style-type: none"> Command: trapezoid Parameter: parallelogram Display: oval Action: hexagon Mode: rounded rectangle Sequential transfer: wavy-bottom rectangle | | | | | | | | | | | | |

10.2.13 WRID3 (D2h): Write ID3 Value

| D2H | WRID3 (Write ID3 Value) | | | | | | | | | | | | |
|-------------|---|-----|-----|-------|------|------|------|------|------|------|------|------|-------|
| Inst / Para | D/CX | WRX | RDX | D17-8 | D7 | D6 | D5 | D4 | D3 | D2 | D1 | D0 | HEX |
| WRID3 | 0 | ↑ | 1 | - | 1 | 1 | 0 | 1 | 0 | 0 | 1 | 0 | (D2h) |
| Parameter | 1 | ↑ | 1 | - | ID37 | ID36 | ID35 | ID34 | ID33 | ID32 | ID31 | ID30 | - |
| Description | -Write 8-bit data of project code module to save it to NVM. -The parameter ID3[7:0] is product project ID. | | | | | | | | | | | | |
| Flow Chart | <p>The flow chart shows a trapezoidal symbol labeled 'WRID3 (D2h)' with an arrow pointing down to a parallelogram symbol labeled '1st Parameter'. To the right, a dashed box contains a legend with the following items:</p> <ul style="list-style-type: none"> Command: trapezoid Parameter: parallelogram Display: oval Action: hexagon Mode: rounded rectangle Sequential transfer: wavy rectangle | | | | | | | | | | | | |

10.2.14 NVFCTR1 (D9h): NVM Control Status

| D9H | NVFCTR1 (NV Memory Function Controller 1) | | | | | | | | | | | | |
|-------------|---|---|--|-------|----|--------|--------|----|----|----|----|-------|-------|
| Inst / Para | D/CX | WRX | RDX | D17-8 | D7 | D6 | D5 | D4 | D3 | D2 | D1 | D0 | HEX |
| NVFCTR1 | 0 | ↑ | 1 | - | 1 | 1 | 0 | 0 | 1 | 0 | 0 | 1 | (D9h) |
| Parameter | 1 | 1 | ↑ | - | 0 | VMF_EN | ID2_EN | 0 | 0 | 0 | 0 | EXT_R | |
| Description | -NVM control status | | | | | | | | | | | | |
| | Bit | | Value | | | | | | | | | | |
| | VMF_EN | | "1" = Command C7h Enable ; "0" = Command C7h Disable | | | | | | | | | | |
| | ID2_EN | | "1" = Command D1h Enable ; "0" = Command D1h Disable | | | | | | | | | | |
| EXT_R | | Read: Extension Command Status, "1" for Enable, "0" for Disable. | | | | | | | | | | | |
| Default | Status | | Default Value (D9h) | | | | | | | | | | |
| | Power On Sequence | | 00h | | | | | | | | | | |
| | S/W Reset | | 00h | | | | | | | | | | |
| | H/W Reset | | 00h | | | | | | | | | | |
| Flow Chart | <pre> graph TD A[NVFCTR (D9h)] --> B[1st Parameter] </pre> <p>Legend</p> <ul style="list-style-type: none"> Command: Trapezoid Parameter: Parallelogram Display: Oval Action: Hexagon Mode: Rounded rectangle Sequential transfer: Wavy rectangle | | | | | | | | | | | | |

10.2.15 NVFCTR2 (Deh): NVM Read Command

| DEH | NVFCTR1 (NV Memory Function Controller 2) | | | | | | | | | | | | |
|---------------------------|--|-----|-----|-------|----|----|----|----|----|----|----|----|-------|
| Inst / Para | D/CX | WRX | RDX | D17-8 | D7 | D6 | D5 | D4 | D3 | D2 | D1 | D0 | HEX |
| NVFCTR2 | 0 | ↑ | 1 | - | 1 | 1 | 0 | 1 | 1 | 1 | 1 | 0 | (Deh) |
| 1 st Parameter | 1 | ↑ | 1 | | 1 | 1 | 1 | 1 | 0 | 1 | 0 | 1 | F5 |
| 2 nd Parameter | 1 | ↑ | 1 | | 1 | 0 | 1 | 0 | 0 | 1 | 0 | 1 | A5 |
| Description | NVM Read Command NOTE: "-" Don't care | | | | | | | | | | | | |
| Flow Chart | <p>The flow chart shows a trapezoidal box labeled 'NVFCTR2' with a downward arrow pointing to a parallelogram box containing '1st Para : F5h' and '2nd Para : A5h'. To the right is a legend box with a dashed border containing six symbols: a trapezoid for 'Command', a parallelogram for 'Parameter', an oval for 'Display', a hexagon for 'Action', a rounded rectangle for 'Mode', and a wavy rectangle for 'Sequential transfer'.</p> | | | | | | | | | | | | |

10.2.16 NVFCTR3 (DFh): NVM Write Command

| DFH | NVFCTR1 (NV Memory Function Controller 3) | | | | | | | | | | | | |
|---------------------------|---|-----|-----|-------|----------|----------|----------|----------|----------|----------|----------|----------|-------|
| Inst / Para | D/CX | WRX | RDX | D17-8 | D7 | D6 | D5 | D4 | D3 | D2 | D1 | D0 | HEX |
| NVFCTR1 | 0 | ↑ | 1 | - | 1 | 1 | 0 | 1 | 1 | 1 | 1 | 1 | (DFh) |
| 1 st Parameter | 1 | ↑ | 1 | | NVM_CMD7 | NVM_CMD6 | NVM_CMD5 | NVM_CMD4 | NVM_CMD3 | NVM_CMD2 | NVM_CMD1 | NVM_CMD0 | |
| 2 nd Parameter | 1 | ↑ | 1 | | 1 | 0 | 1 | 0 | 0 | 1 | 0 | 1 | A5 |
| Description | -NVM Write Command -NVM_CMD[7:0] : Select to Program/Erase ; Program command : 3Ah ; Erase command : C5h NOTE: “-“ Don't care | | | | | | | | | | | | |

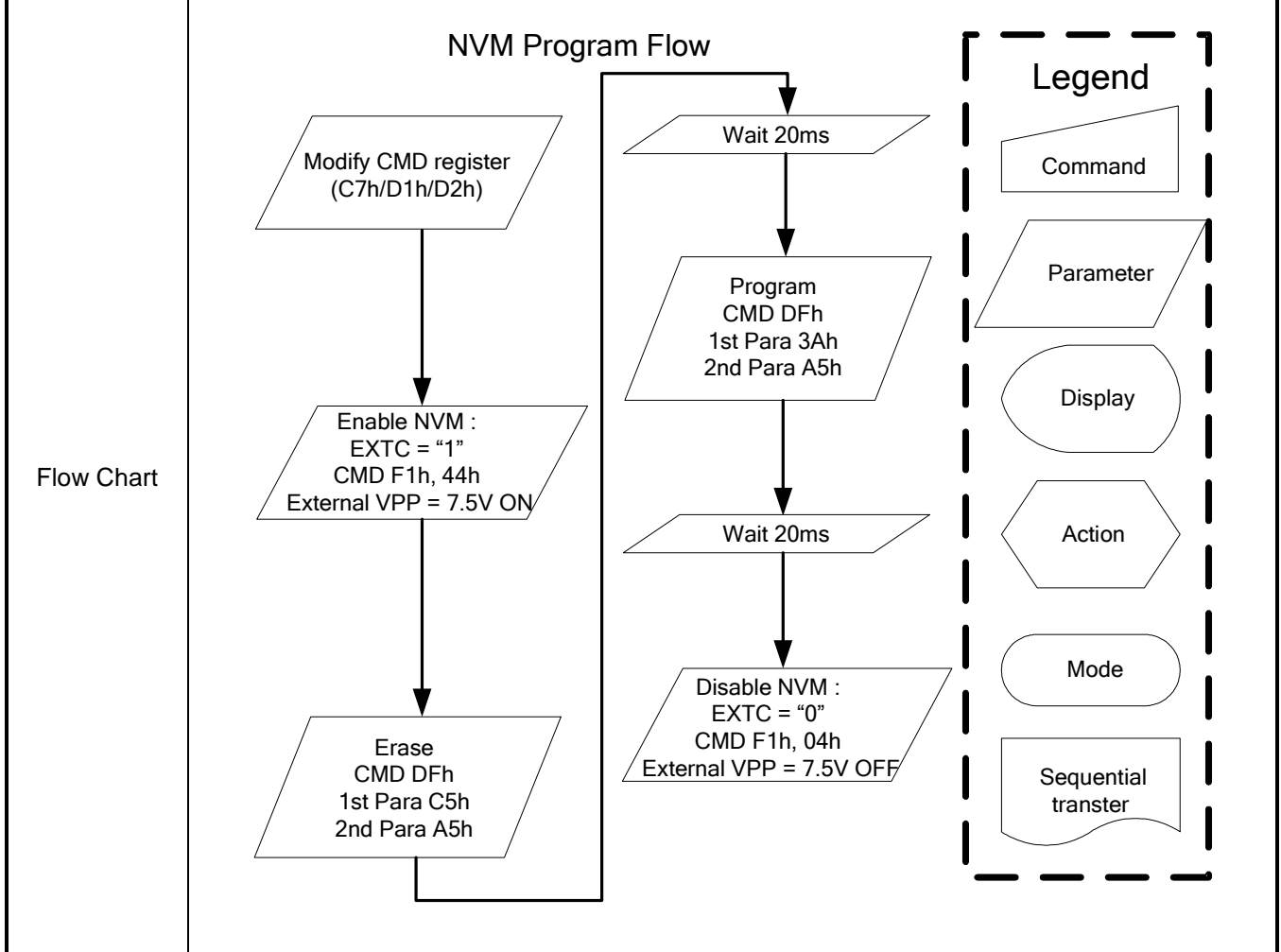

10.2.17 GMCTRP1 (E0h): Gamma ('+'polarity) Correction Characteristics Setting

| E0H | | GMCTRP0 (Gamma '+'Polarity Correction Characteristics Setting) | | | | | | | | | | | |
|----------------------------|-----------------------|--|---|------------------------|---|----|------------|------------|------------|------------|------------|------------|-------|
| Inst / Para | D/CX | WRX | RDX | D17-8 | D7 | D6 | D5 | D4 | D3 | D2 | D1 | D0 | HEX |
| GMCTRP1 | 0 | ↑ | 1 | - | 1 | 1 | 1 | 0 | 0 | 0 | 0 | 0 | (E0h) |
| 1 st Parameter | 1 | ↑ | 1 | - | - | - | VRF0P[5] | VRF0P[4] | VRF0P[3] | VRF0P[2] | VRF0P[1] | VRF0P[0] | |
| 2 nd Parameter | 1 | ↑ | 1 | - | - | - | VOS0P[5] | VOS0P[4] | VOS0P[3] | VOS0P[2] | VOS0P[1] | VOS0P[0] | |
| 3 rd Parameter | 1 | ↑ | 1 | - | - | - | PK0P[5] | PK0P[4] | PK0P[3] | PK0P[2] | PK0P[1] | PK0P[0] | |
| 4 th Parameter | 1 | ↑ | 1 | - | - | - | PK1P[5] | PK1P[4] | PK1P[3] | PK1P[2] | PK1P[1] | PK1P[0] | |
| 5 th Parameter | 1 | ↑ | 1 | - | - | - | PK2P[5] | PK2P[4] | PK2P[3] | PK2P[2] | PK2P[1] | PK2P[0] | |
| 6 th Parameter | 1 | ↑ | 1 | - | - | - | PK3P[5] | PK3P[4] | PK3P[3] | PK3P[2] | PK3P[1] | PK3P[0] | |
| 7 th Parameter | 1 | ↑ | 1 | - | - | - | PK4P[5] | PK4P[4] | PK4P[3] | PK4P[2] | PK4P[1] | PK4P[0] | |
| 8 th Parameter | 1 | ↑ | 1 | - | - | - | PK5P[5] | PK5P[4] | PK5P[3] | PK5P[2] | PK5P[1] | PK5P[0] | |
| 9 th Parameter | 1 | ↑ | 1 | - | - | - | PK6P[5] | PK6P[4] | PK6P[3] | PK6P[2] | PK6P[1] | PK6P[0] | |
| 10 th Parameter | 1 | ↑ | 1 | - | - | - | PK7P[5] | PK7P[4] | PK7P[3] | PK7P[2] | PK7P[1] | PK7P[0] | |
| 11 th Parameter | 1 | ↑ | 1 | - | - | - | PK8P[5] | PK8P[4] | PK8P[3] | PK8P[2] | PK8P[1] | PK8P[0] | |
| 12 th Parameter | 1 | ↑ | 1 | - | - | - | PK9P[5] | PK9P[4] | PK9P[3] | PK9P[2] | PK9P[1] | PK9P[0] | |
| 13 th Parameter | 1 | ↑ | 1 | - | - | - | SELV0P[5] | SELV0P[4] | SELV0P[3] | SELV0P[2] | SELV0P[1] | SELV0P[0] | |
| 14 th Parameter | 1 | ↑ | 1 | - | - | - | SELV1P[5] | SELV1P[4] | SELV1P[3] | SELV1P[2] | SELV1P[1] | SELV1P[0] | |
| 15 th Parameter | 1 | ↑ | 1 | - | - | - | SELV62P[5] | SELV62P[4] | SELV62P[3] | SELV62P[2] | SELV62P[1] | SELV62P[0] | |
| 16 th Parameter | 1 | ↑ | 1 | - | - | - | SELV63P[5] | SELV63P[4] | SELV63P[3] | SELV63P[2] | SELV63P[1] | SELV63P[0] | |
| Description | Register Group | | Positive Polarity | | Set-up Contents | | | | | | | | |
| | High Level adjustment | | VRF0P[5:0] | | Variable resistor VRHP | | | | | | | | |
| | Mid Level Adjustment | | SELV0P[5:0] | | The voltage of V0 grayscale is selected by the 64 to 1 | | | | | | | | |
| | | | SELV1P[5:0] | | The voltage of V1 grayscale is selected by the 64 to 1 | | | | | | | | |
| | | | PK0P[5:0] | | The voltage of V3 grayscale is selected by the 64 to 1 | | | | | | | | |
| | | | PK1P[5:0] | | The voltage of V4 grayscale is selected by the 64 to 1 | | | | | | | | |
| | | | PK2P[5:0] | | The voltage of V12 grayscale is selected by the 64 to 1 | | | | | | | | |
| | | | PK3P[5:0] | | The voltage of V20 grayscale is selected by the 64 to 1 | | | | | | | | |
| | | | PK4P[5:0] | | The voltage of V28 grayscale is selected by the 64 to 1 | | | | | | | | |
| | | | PK5P[5:0] | | The voltage of V36 grayscale is selected by the 64 to 1 | | | | | | | | |
| | | | PK6P[5:0] | | The voltage of V44 grayscale is selected by the 64 to 1 | | | | | | | | |
| | | | PK7P[5:0] | | The voltage of V52 grayscale is selected by the 64 to 1 | | | | | | | | |
| | | | PK8P[5:0] | | The voltage of V56 grayscale is selected by the 64 to 1 | | | | | | | | |
| | | | PK9P[5:0] | | The voltage of V60 grayscale is selected by the 64 to 1 | | | | | | | | |
| | SELV62P[5:0] | | The voltage of V62 grayscale is selected by the 64 to 1 | | | | | | | | | | |
| SELV63P[5:0] | | The voltage of V63 grayscale is selected by the 64 to 1 | | | | | | | | | | | |
| Low Level Adjustment | | VOS0P[5:0] | | Variable Resistor VRLP | | | | | | | | | |

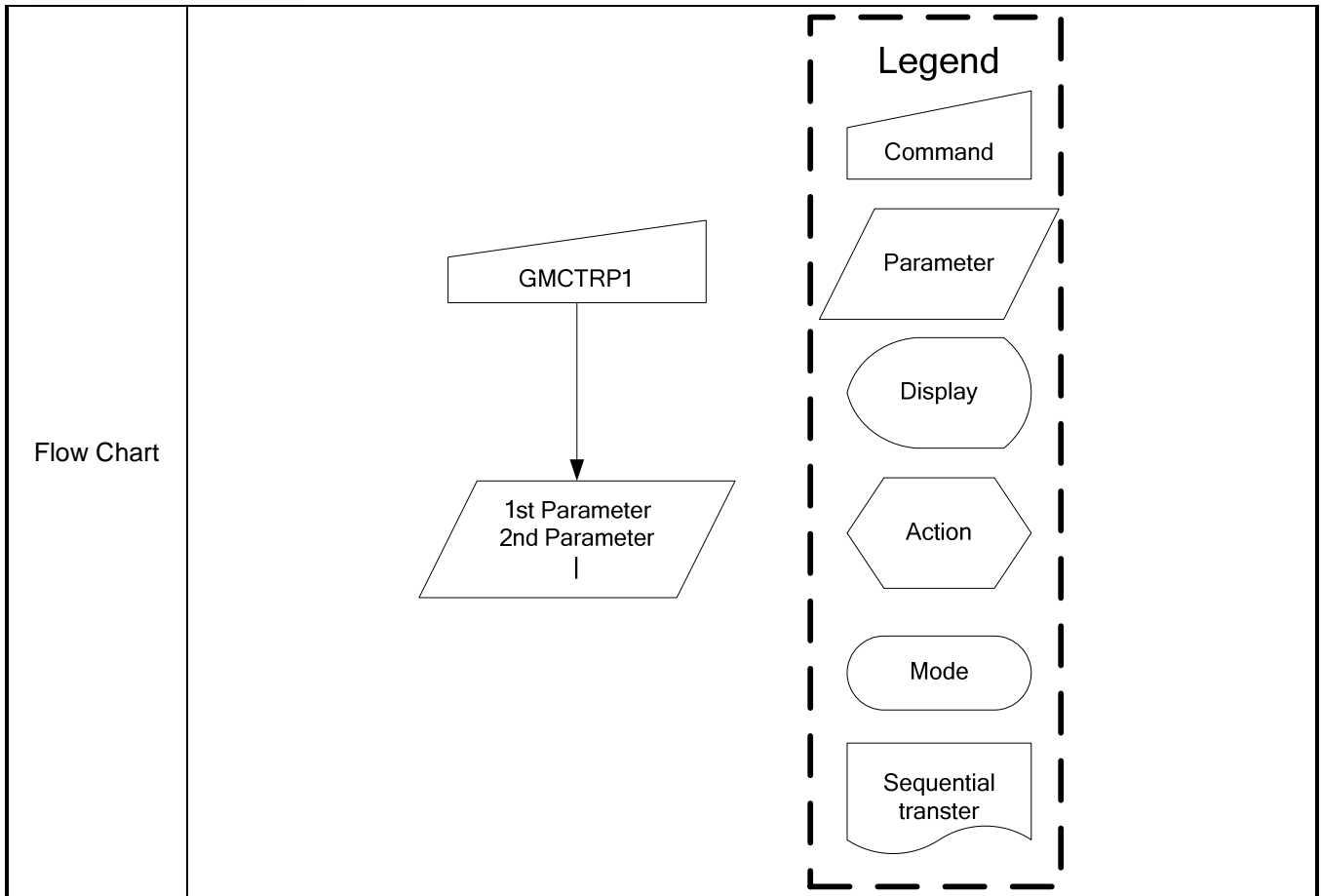

10.2.18 GMCTRN1 (E1h): Gamma '-' polarity Correction Characteristics Setting

| E1H | GMCTRP0 (Gamma '+' Polarity Correction Characteristics Setting) | | | | | | | | | | | | |
|----------------------------|---|---|---|---|----|----|------------|------------|------------|------------|------------|------------|-------|
| Inst / Para | D/CX | WRX | RDX | D17-8 | D7 | D6 | D5 | D4 | D3 | D2 | D1 | D0 | HEX |
| GMCTRP1 | 0 | ↑ | 1 | - | 1 | 1 | 1 | 0 | 0 | 0 | 0 | 1 | (E1h) |
| 1 st Parameter | 1 | ↑ | 1 | - | - | - | VRF0N[5] | VRF0N[4] | VF0N[3] | VRF0N[2] | VRF0N[1] | VRF0N[0] | |
| 2 nd Parameter | 1 | ↑ | 1 | - | - | - | VOS0N[5] | VOS0N[4] | VOS0N[3] | VOS0N[2] | VOS0N[1] | VOS0N[0] | |
| 3 rd Parameter | 1 | ↑ | 1 | - | - | - | PK0N[5] | PK0N[4] | PK0N[3] | PK0N[2] | PK0N[1] | PK0N[0] | |
| 4 th Parameter | 1 | ↑ | 1 | - | - | - | PK1N[5] | PK1N[4] | PK1N[3] | PK1N[2] | PK1N[1] | PK1N[0] | |
| 5 th Parameter | 1 | ↑ | 1 | - | - | - | PK2N[5] | PK2N[4] | PK2N[3] | PK2N[2] | PK2N[1] | PK2N[0] | |
| 6 th Parameter | 1 | ↑ | 1 | - | - | - | PK3N[5] | PK3N[4] | PK3N[3] | PK3N[2] | PK3N[1] | PK3N[0] | |
| 7 th Parameter | 1 | ↑ | 1 | - | - | - | PK4N[5] | PK4N[4] | PK4N[3] | PK4N[2] | PK4N[1] | PK4N[0] | |
| 8 th Parameter | 1 | ↑ | 1 | - | - | - | PK5N[5] | PK5N[4] | PK5N[3] | PK5N[2] | PK5N[1] | PK5N[0] | |
| 9 th Parameter | 1 | ↑ | 1 | - | - | - | PK6N[5] | PK6N[4] | PK6N[3] | PK6N[2] | PK6N[1] | PK6N[0] | |
| 10 th Parameter | 1 | ↑ | 1 | - | - | - | PK7N[5] | PK7N[4] | PK7N[3] | PK7N[2] | PK7N[1] | PK7N[0] | |
| 11 th Parameter | 1 | ↑ | 1 | - | - | - | PK8N[5] | PK8N[4] | PK8N[3] | PK8N[2] | PK8N[1] | PK8N[0] | |
| 12 th Parameter | 1 | ↑ | 1 | - | - | - | PK9[5] | PK9N[4] | PK9N[3] | PK9N[2] | PK9N[1] | PK9N[0] | |
| 13 th Parameter | 1 | ↑ | 1 | - | - | - | SELV0N[5] | SELV0N[4] | SELV0N[3] | SELV0N[2] | SELV0N[1] | SELV0N[0] | |
| 14 th Parameter | 1 | ↑ | 1 | - | - | - | SELV1N[5] | SELV1N[4] | SELV1N[3] | SELV1N[2] | SELV1N[1] | SELV1N[0] | |
| 15 th Parameter | 1 | ↑ | 1 | - | - | - | SELV62N[5] | SELV62N[4] | SELV62N[3] | SELV62N[2] | SELV62N[1] | SELV62N[0] | |
| 16 th Parameter | 1 | ↑ | 1 | - | - | - | SELV63N[5] | SELV63N[4] | SELV63N[3] | SELV63N[2] | SELV63N[1] | SELV63N[0] | |
| Description | Register Group | | Negative Polarity | Set-up Contents | | | | | | | | | |
| | High level adjustment | | VRF0N[5:0] | Variable resistor VRHN | | | | | | | | | |
| | Mid Level Adjustment | | SELV0N[5:0] | The voltage of V0 grayscale is selected by the 64 to 1 | | | | | | | | | |
| | | | SELV1N[5:0] | The voltage of V1 grayscale is selected by the 64 to 1 | | | | | | | | | |
| | | | PK0N[5:0] | The voltage of V3 grayscale is selected by the 64 to 1 | | | | | | | | | |
| | | | PK1N[5:0] | The voltage of V4 grayscale is selected by the 64 to 1 | | | | | | | | | |
| | | | PK2N[5:0] | The voltage of V12 grayscale is selected by the 64 to 1 | | | | | | | | | |
| | | | PK3N[5:0] | The voltage of V20 grayscale is selected by the 64 to 1 | | | | | | | | | |
| | | | PK4N[5:0] | The voltage of V28 grayscale is selected by the 64 to 1 | | | | | | | | | |
| | | | PK5N[5:0] | The voltage of V36 grayscale is selected by the 64 to 1 | | | | | | | | | |
| | | | PK6N[5:0] | The voltage of V44 grayscale is selected by the 64 to 1 | | | | | | | | | |
| | | | PK7N[5:0] | The voltage of V52 grayscale is selected by the 64 to 1 | | | | | | | | | |
| | | | PK8N[5:0] | The voltage of V56 grayscale is selected by the 64 to 1 | | | | | | | | | |
| | PK9N[5:0] | The voltage of V60 grayscale is selected by the 64 to 1 | | | | | | | | | | | |
| Low Level Adjustment | | SELV62N[5:0] | The voltage of V62 grayscale is selected by the 64 to 1 | | | | | | | | | | |
| | | SELV63N[5:0] | The voltage of V63 grayscale is selected by the 64 to 1 | | | | | | | | | | |
| Low Level Adjustment | | VOS0N[5:0] | Variable Resistor VRLN | | | | | | | | | | |

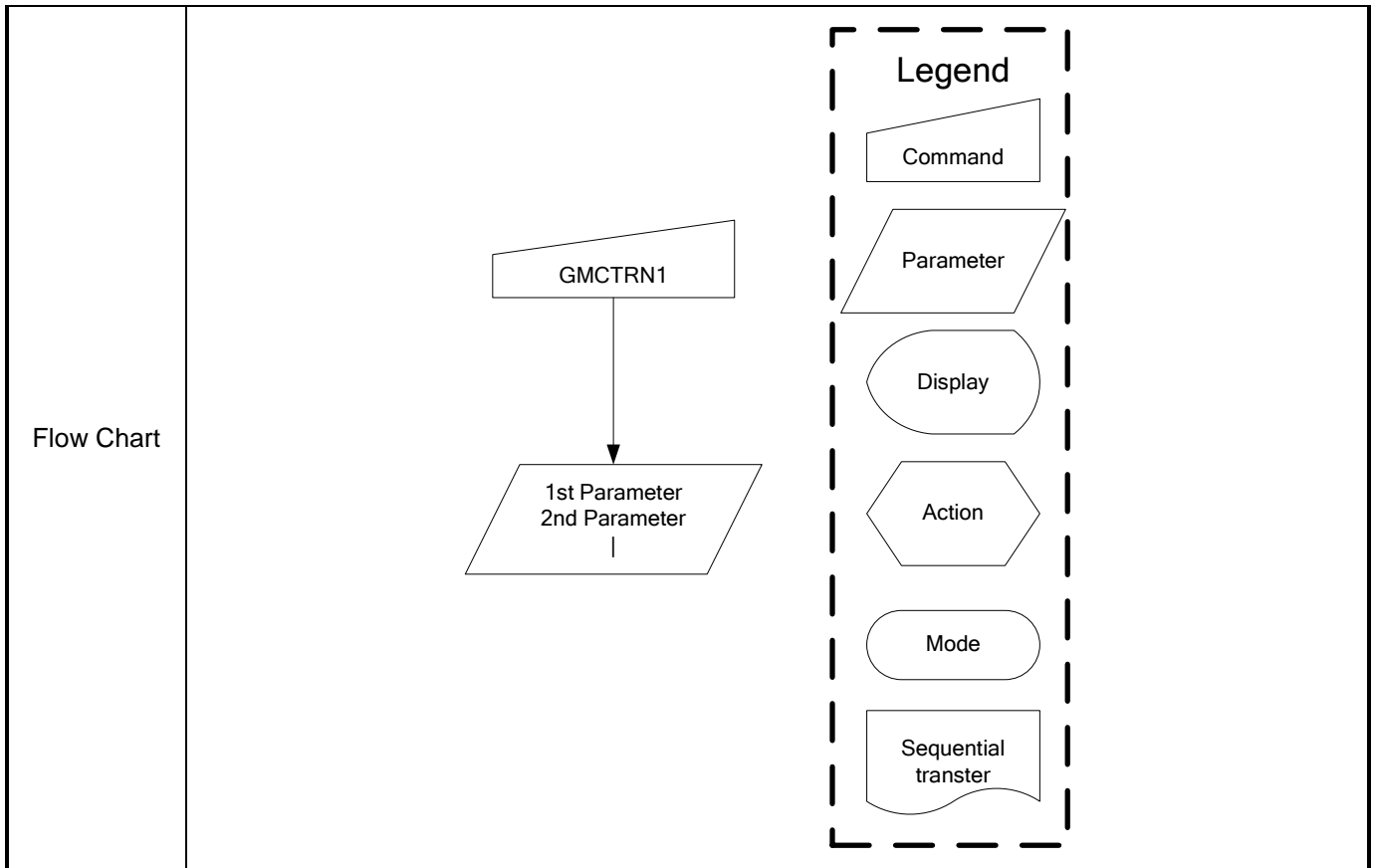

10.2.19 GCV(FCh): Gate Pump Clock Frequency Variable

| FCH | Gate Pump Clock Frequency Variable | | | | | | | | | | | | | | | | | | | | | | |
|---|---|---------------------------|-----|-------|--------------|--------------|----|--------------|--------------|----|----|----|-------------------|--------------------|---------------------------|-------------------|---------|-----------|----------|-----------|----------|-------|--------|
| Inst / Para | D/CX | WRX | RDX | D17-8 | D7 | D6 | D5 | D4 | D3 | D2 | D1 | D0 | HEX | | | | | | | | | | |
| NVFCR1 | 0 | ↑ | 1 | - | 1 | 1 | 0 | 1 | 1 | 0 | 0 | 1 | (FCh) | | | | | | | | | | |
| Parameter | 1 | 1 | ↑ | - | GCV_Enabled1 | GCV_Enabled0 | 0 | Clk_Variable | Clk_Variable | | 0 | 0 | | | | | | | | | | | |
| Description | -Automatic adjust gate pumping clock for saving power consumption. | | | | | | | | | | | | | | | | | | | | | | |
| | <table border="1"> <thead> <tr> <th>GCV_Enable[1:0]</th> <th>Gate Pump Clock Frequency</th> </tr> </thead> <tbody> <tr> <td>00</td> <td>Disable</td> </tr> <tr> <td>01</td> <td>Reserved</td> </tr> <tr> <td>10</td> <td>Reserved</td> </tr> <tr> <td>11</td> <td>Enable</td> </tr> </tbody> </table> | | | | | | | | | | | | | GCV_Enable[1:0] | Gate Pump Clock Frequency | 00 | Disable | 01 | Reserved | 10 | Reserved | 11 | Enable |
| | GCV_Enable[1:0] | Gate Pump Clock Frequency | | | | | | | | | | | | | | | | | | | | | |
| 00 | Disable | | | | | | | | | | | | | | | | | | | | | | |
| 01 | Reserved | | | | | | | | | | | | | | | | | | | | | | |
| 10 | Reserved | | | | | | | | | | | | | | | | | | | | | | |
| 11 | Enable | | | | | | | | | | | | | | | | | | | | | | |
| <table border="1"> <thead> <tr> <th>Clk_Variable[1:0]</th> <th>Save Power Ability</th> </tr> </thead> <tbody> <tr> <td>00</td> <td>Small</td> </tr> <tr> <td>01</td> <td>Medium</td> </tr> <tr> <td>10</td> <td>High</td> </tr> <tr> <td>11</td> <td>Large</td> </tr> </tbody> </table> | | | | | | | | | | | | | Clk_Variable[1:0] | Save Power Ability | 00 | Small | 01 | Medium | 10 | High | 11 | Large | |
| Clk_Variable[1:0] | Save Power Ability | | | | | | | | | | | | | | | | | | | | | | |
| 00 | Small | | | | | | | | | | | | | | | | | | | | | | |
| 01 | Medium | | | | | | | | | | | | | | | | | | | | | | |
| 10 | High | | | | | | | | | | | | | | | | | | | | | | |
| 11 | Large | | | | | | | | | | | | | | | | | | | | | | |
| Default | <table border="1"> <thead> <tr> <th>Status</th> <th>Default Value (FCh)</th> </tr> </thead> <tbody> <tr> <td>Power On Sequence</td> <td>80h</td> </tr> <tr> <td>S/W Reset</td> <td>80h</td> </tr> <tr> <td>H/W Reset</td> <td>80h</td> </tr> </tbody> </table> | | | | | | | | | | | | | Status | Default Value (FCh) | Power On Sequence | 80h | S/W Reset | 80h | H/W Reset | 80h | | |
| | Status | Default Value (FCh) | | | | | | | | | | | | | | | | | | | | | |
| Power On Sequence | 80h | | | | | | | | | | | | | | | | | | | | | | |
| S/W Reset | 80h | | | | | | | | | | | | | | | | | | | | | | |
| H/W Reset | 80h | | | | | | | | | | | | | | | | | | | | | | |
| Flow Chart | <pre> graph TD GCV[Command] --> Param[/1st Parameter/] </pre> | | | | | | | | | | | | | | | | | | | | | | |
| | <p>Legend</p> <ul style="list-style-type: none"> Command (trapezoid) Parameter (parallelogram) Display (oval) Action (hexagon) Mode (rounded rectangle) Sequential transfer (wavy rectangle) | | | | | | | | | | | | | | | | | | | | | | |

11 Power Sturcture

11.1 Driver IC Operating Voltage Specification

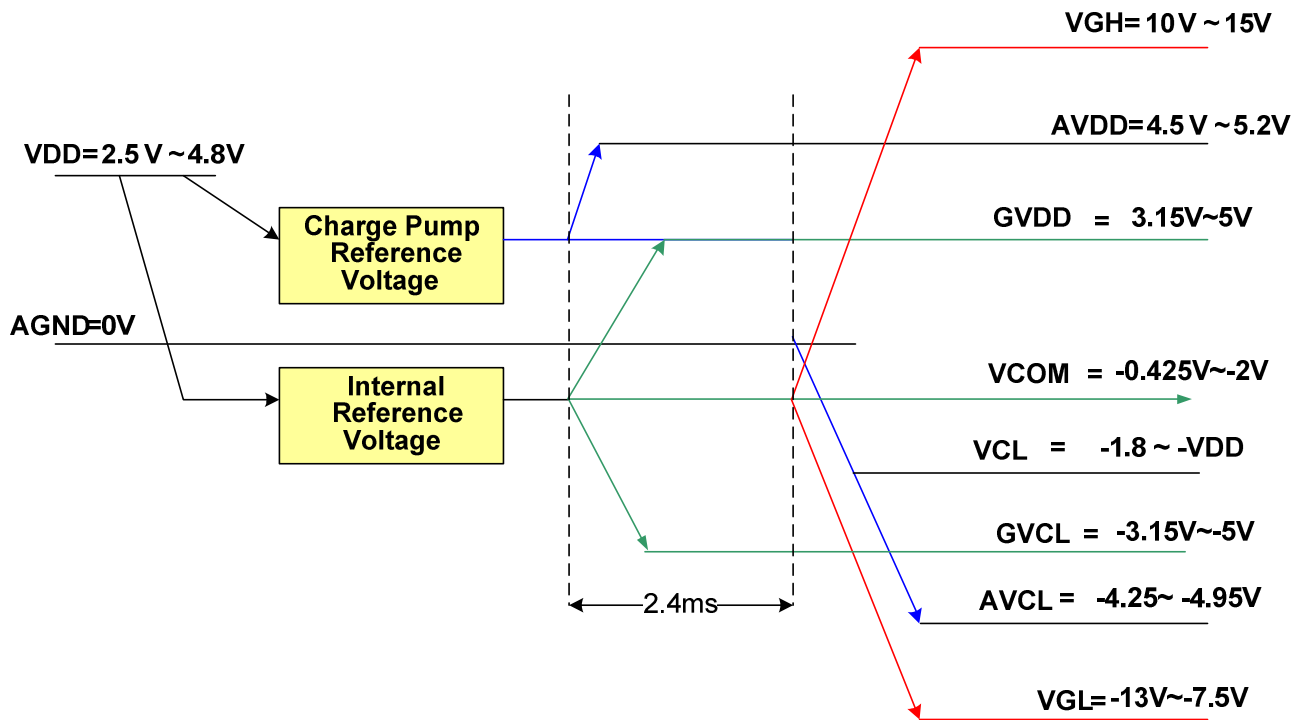

Fig 15 Power Booster Level

Note:

Sleep out flow: AVDD, GVDD, GVCL, VCOM switch on -> 2.4ms -> AVCL, VGH, VGL, VCL switch on -> 78.6ms

scan 2 blank frames

Sleep in flow: Scan 2 blank frames -> All analog power

11.2 Power Booster Circuit

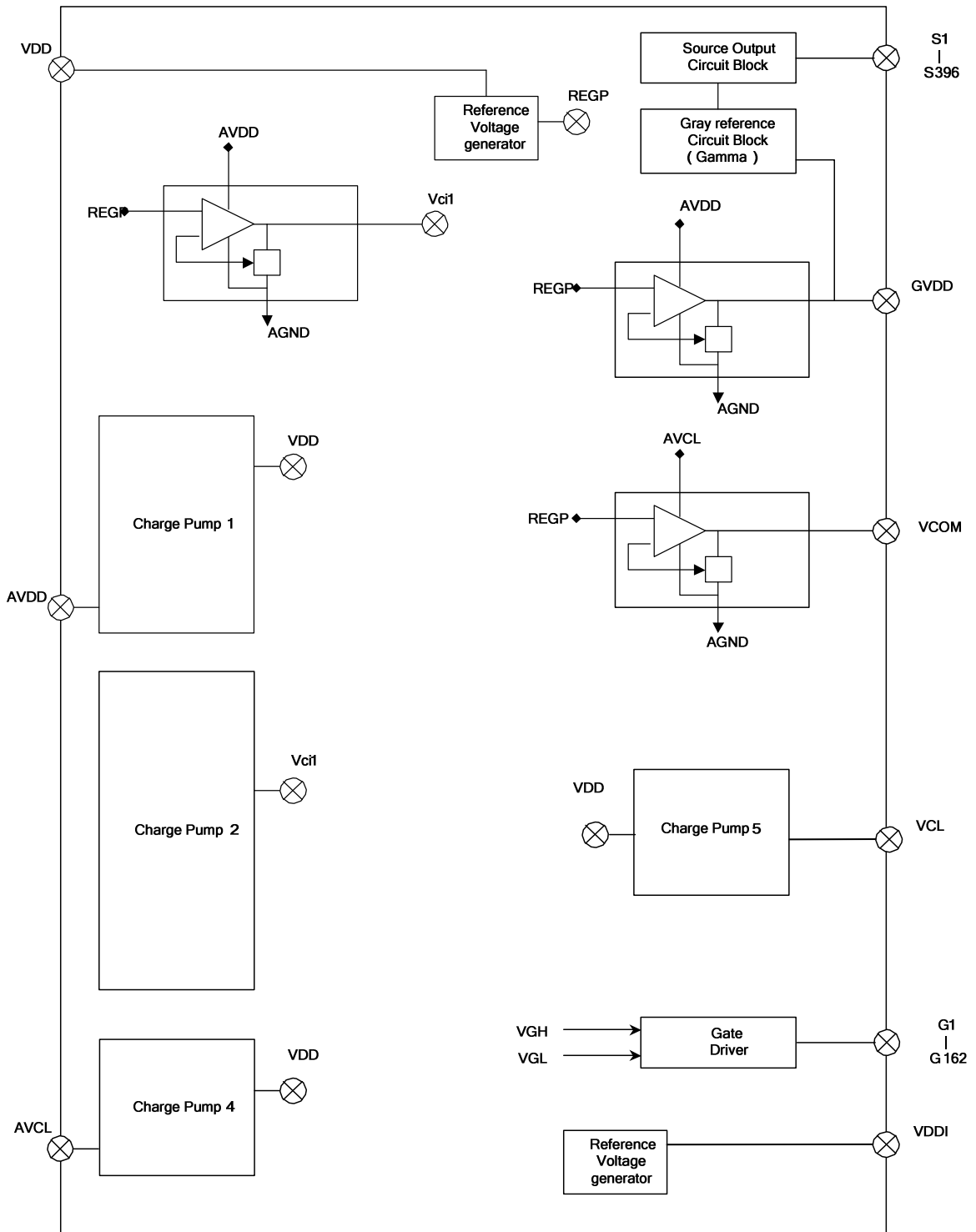

12 Gamma Structure

12.1 Structure of Grayscale Amplifier

16 voltage levels (VIN0-VIN15) between GVDD(GVCL) and VSS are determined by the high/ mid/ low level adjustment registers. Each mid-adjustment level is split into 64 levels again by the internal ladder resistor network. As a result, grayscale amplifier generates 64 voltage levels ranging from V0 to V63 and outputs one of 64 levels.

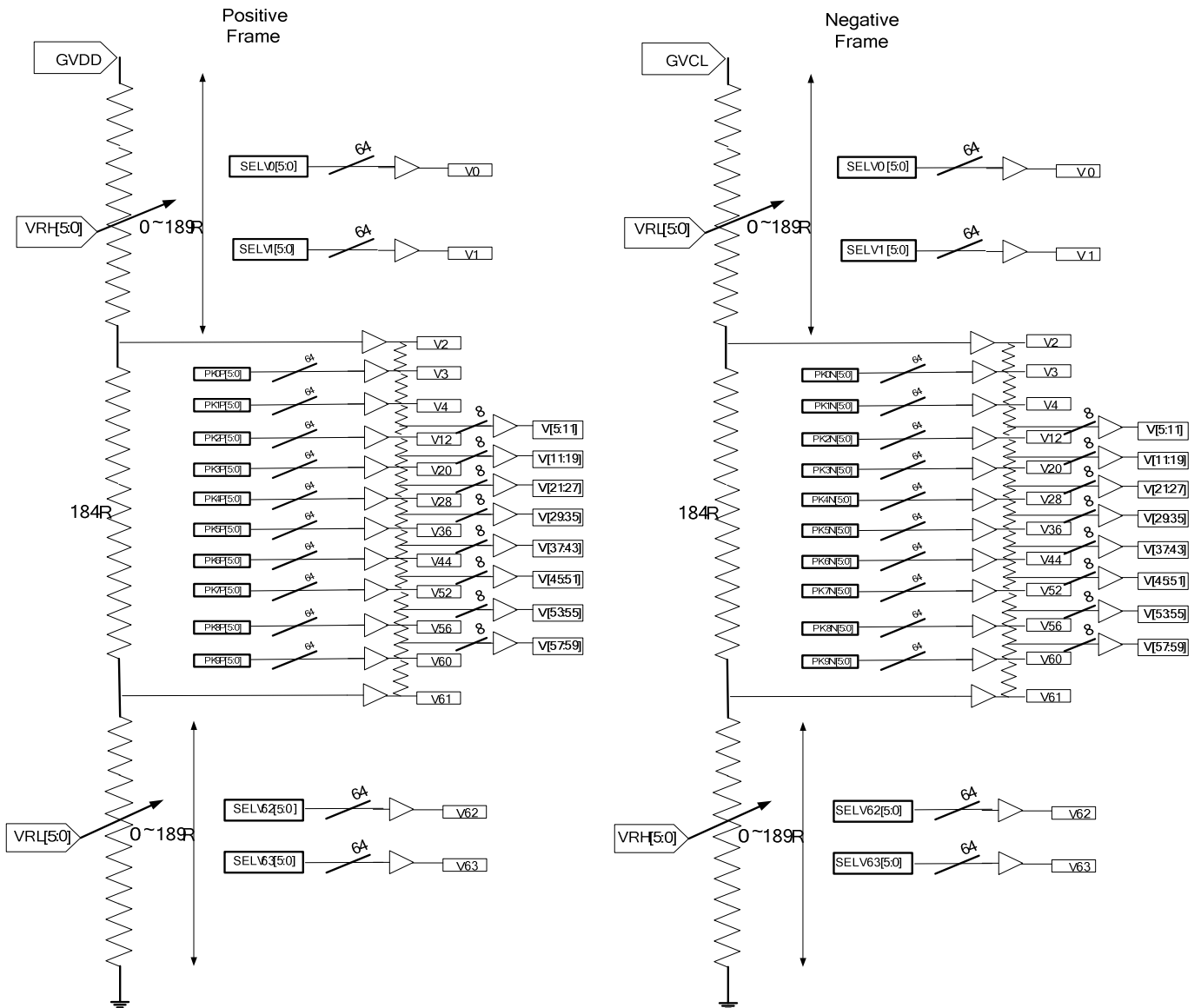

12.2 Gamma Voltage Formula (Positive/ Negative Polarity)

| Gray Level | Voltage Formula (Positive) | Voltage Formula (Negative) |
|------------|----------------------------|----------------------------|
| 0 | VINP0 | VINP0 |
| 1 | VINP1 | VINP1 |
| 2 | VINP2 | VINP2 |
| 3 | VINP3 | VINP3 |
| 4 | VINP4 | VINP4 |
| 5 | $V4-(V4-V12)*(4/32)$ | $V4-(V4-V12)*(4/32)$ |
| 6 | $V4-(V4-V12)*(8/32)$ | $V4-(V4-V12)*(8/32)$ |
| 7 | $V4-(V4-V12)*(12/32)$ | $V4-(V4-V12)*(12/32)$ |
| 8 | $V4-(V4-V12)*(16/32)$ | $V4-(V4-V12)*(16/32)$ |
| 9 | $V4-(V4-V12)*(20/32)$ | $V4-(V4-V12)*(20/32)$ |
| 10 | $V4-(V4-V12)*(24/32)$ | $V4-(V4-V12)*(24/32)$ |
| 11 | $V4-(V4-V12)*(28/32)$ | $V4-(V4-V12)*(28/32)$ |
| 12 | VINP5 | VINP5 |
| 13 | $V12-(V12-V20)*(4/32)$ | $V12-(V12-V20)*(4/32)$ |
| 14 | $V12-(V12-V20)*(8/32)$ | $V12-(V12-V20)*(8/32)$ |
| 15 | $V12-(V12-V20)*(12/32)$ | $V12-(V12-V20)*(12/32)$ |
| 16 | $V12-(V12-V20)*(16/32)$ | $V12-(V12-V20)*(16/32)$ |
| 17 | $V12-(V12-V20)*(20/32)$ | $V12-(V12-V20)*(20/32)$ |
| 18 | $V12-(V12-V20)*(24/32)$ | $V12-(V12-V20)*(24/32)$ |
| 19 | $V12-(V12-V20)*(28/32)$ | $V12-(V12-V20)*(28/32)$ |
| 20 | VINP6 | VINP6 |
| 21 | $V20-(V20-V28)*(4/32)$ | $V20-(V20-V28)*(4/32)$ |
| 22 | $V20-(V20-V28)*(8/32)$ | $V20-(V20-V28)*(8/32)$ |
| 23 | $V20-(V20-V28)*(12/32)$ | $V20-(V20-V28)*(12/32)$ |
| 24 | $V20-(V20-V28)*(16/32)$ | $V20-(V20-V28)*(16/32)$ |
| 25 | $V20-(V20-V28)*(20/32)$ | $V20-(V20-V28)*(20/32)$ |
| 26 | $V20-(V20-V28)*(24/32)$ | $V20-(V20-V28)*(24/32)$ |
| 27 | $V20-(V20-V28)*(28/32)$ | $V20-(V20-V28)*(28/32)$ |
| 28 | VINP7 | VINP7 |
| 29 | $V28-(V28-V36)*(4/32)$ | $V28-(V28-V36)*(4/32)$ |
| 30 | $V28-(V28-V36)*(8/32)$ | $V28-(V28-V36)*(8/32)$ |
| 31 | $V28-(V28-V36)*(12/32)$ | $V28-(V28-V36)*(12/32)$ |
| 32 | $V28-(V28-V36)*(16/32)$ | $V28-(V28-V36)*(16/32)$ |
| 33 | $V28-(V28-V36)*(20/32)$ | $V28-(V28-V36)*(20/32)$ |
| 34 | $V28-(V28-V36)*(24/32)$ | $V28-(V28-V36)*(24/32)$ |
| 35 | $V28-(V28-V36)*(28/32)$ | $V28-(V28-V36)*(28/32)$ |

| | | |
|----|-----------------------|-----------------------|
| 36 | VINP8 | VINP8 |
| 37 | V36-(V36-V44)*(4/32) | V36-(V36-V44)*(4/32) |
| 38 | V36-(V36-V44)*(8/32) | V36-(V36-V44)*(8/32) |
| 39 | V36-(V36-V44)*(12/32) | V36-(V36-V44)*(12/32) |
| 40 | V36-(V36-V44)*(16/32) | V36-(V36-V44)*(16/32) |
| 41 | V36-(V36-V44)*(20/32) | V36-(V36-V44)*(20/32) |
| 42 | V36-(V36-V44)*(24/32) | V36-(V36-V44)*(24/32) |
| 43 | V36-(V36-V44)*(28/32) | V36-(V36-V44)*(28/32) |
| 44 | VINP9 | VINP9 |
| 45 | V44-(V44-V52)*(4/32) | V44-(V44-V52)*(4/32) |
| 46 | V44-(V44-V52)*(8/32) | V44-(V44-V52)*(8/32) |
| 47 | V44-(V44-V52)*(12/32) | V44-(V44-V52)*(12/32) |
| 48 | V44-(V44-V52)*(16/32) | V44-(V44-V52)*(16/32) |
| 49 | V44-(V44-V52)*(20/32) | V44-(V44-V52)*(20/32) |
| 50 | V44-(V44-V52)*(24/32) | V44-(V44-V52)*(24/32) |
| 51 | V44-(V44-V52)*(28/32) | V44-(V44-V52)*(28/32) |
| 52 | VINP10 | VINP10 |
| 53 | V52-(V52-V56)*(1/4) | V52-(V52-V56)*(1/4) |
| 54 | V52-(V52-V56)*(2/4) | V52-(V52-V56)*(2/4) |
| 55 | V52-(V52-V56)*(3/4) | V52-(V52-V56)*(3/4) |
| 56 | VINP11 | VINP11 |
| 57 | V56-(V56-V60)*(1/4) | V56-(V56-V60)*(1/4) |
| 58 | V56-(V56-V60)*(2/4) | V56-(V56-V60)*(2/4) |
| 59 | V56-(V56-V60)*(3/4) | V56-(V56-V60)*(3/4) |
| 60 | VINP12 | VINP12 |
| 61 | VINP13 | VINP13 |
| 62 | VINP14 | VINP14 |
| 63 | VINP15 | VINP15 |

13 Example Connection with Panel Direction and Different Resolution

13.1 Application of Connection with Panel Direction

Case 1: (This is default case)

- 1st Pixel is at Left Top of the panel
- RGB Filter Order = RGB

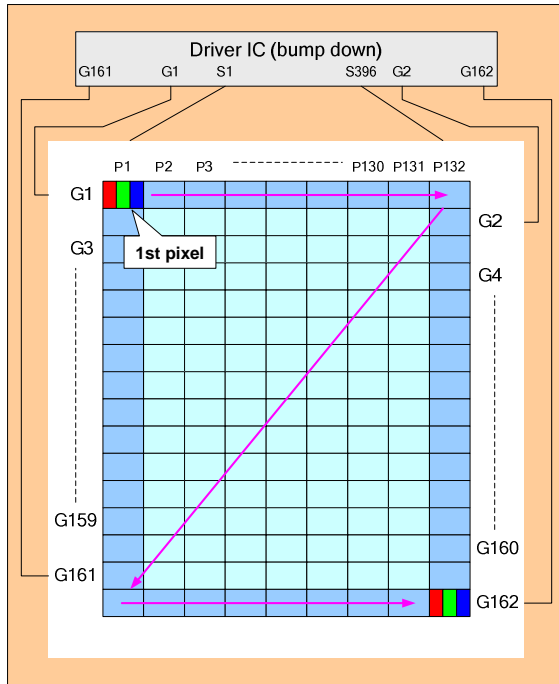

- Direction default setting (H/W)
- SMX = '0'
- SMY = '0'
- SRGB = '0'
- S1 = Filter R
- S2 = Filter G
- S3 = Filter B
- Display direction control (S/W)
- X-Mirror control by MX
- Y-Mirror control by MY
- XY-Exchange control by MV

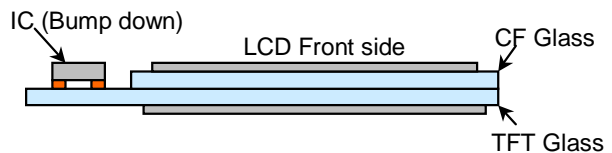

Case 2:

- 1st Pixel is at Left Top of the panel
- RGB Filter Order = BGR

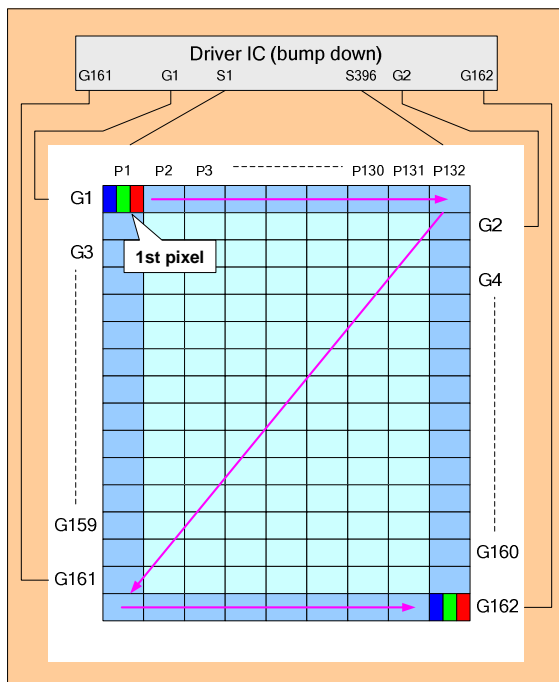

- Direction default setting (H/W)
- SMX = '0'
- SMY = '0'
- SRGB = '1'
- S1 = Filter B
- S2 = Filter G
- S3 = Filter R
- Display direction control (S/W)
- X-Mirror control by MX
- Y-Mirror control by MY
- XY-Exchange control by MV

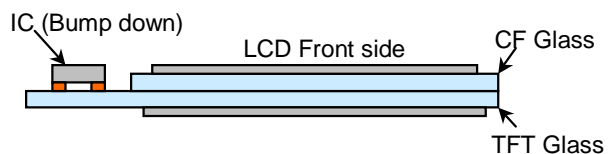

Case 3:

- 1st Pixel is at Right Bottom of the panel
- RGB Filter Order = RGB

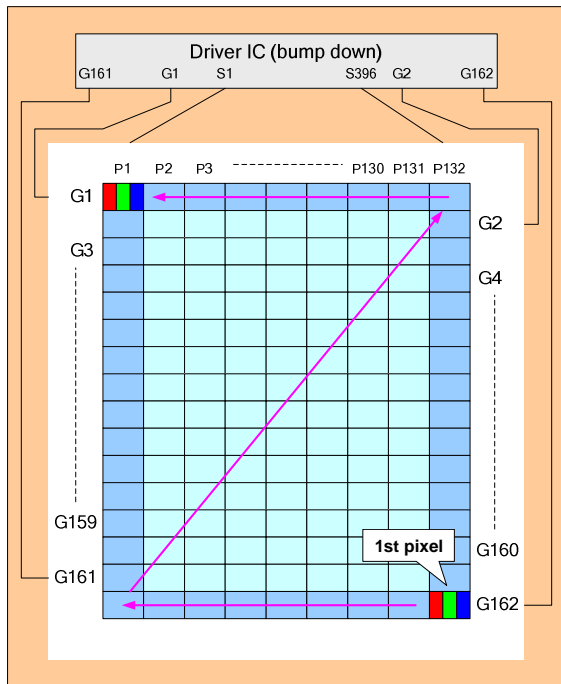

- Direction default setting (H/W)
- SMX = '1'
- SMY = '1'
- SRGB = '0'
- S1 = Filter R
- S2 = Filter G
- S3 = Filter B
- Display direction control (S/W)
- X-Mirror control by MX
- Y-Mirror control by MY
- XY-Exchange control by MV

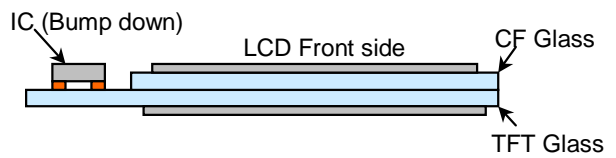

Case 4:

- 1st Pixel is at Right Bottom of the panel
- RGB Filter Order = BGR

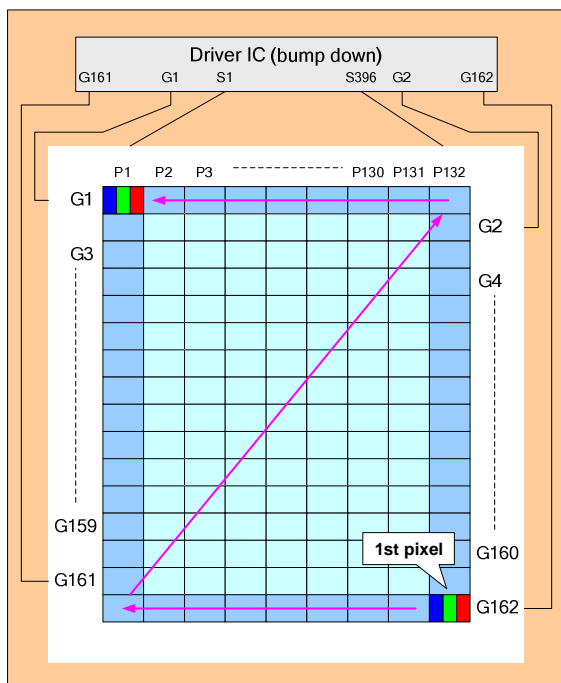

- Direction default setting (H/W)
- SMX = '1'
- SMY = '1'
- SRGB = '1'
- S1 = Filter B
- S2 = Filter G
- S3 = Filter R
- Display direction control (S/W)
- X-Mirror control by MX
- Y-Mirror control by MY
- XY-Exchange control by MV

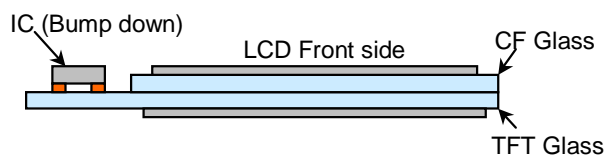

13.2 Application of Connection with Different Resolution

Case1 of Resolution (128RGB x 160) (GM[1:0] = "11")

RAM Size=128 x 160 x 18-bit (Used)

Display Size = 128RGB x 160

1). Example for SMX=SMY='0'

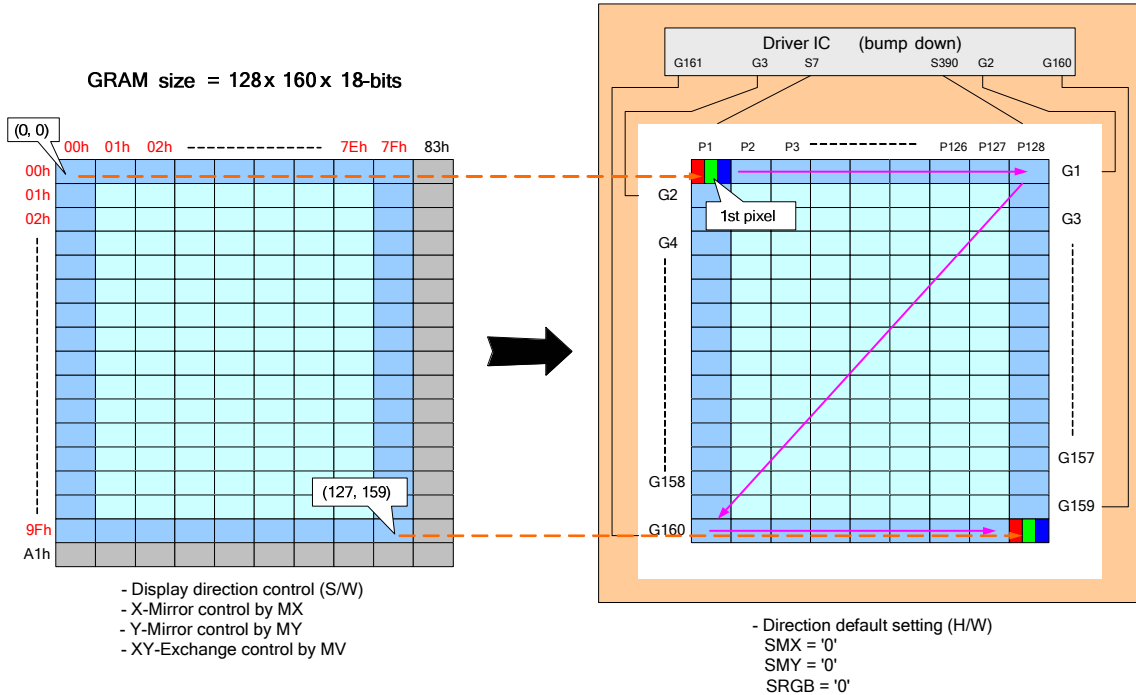

2). Example for SMX=SMY='1'

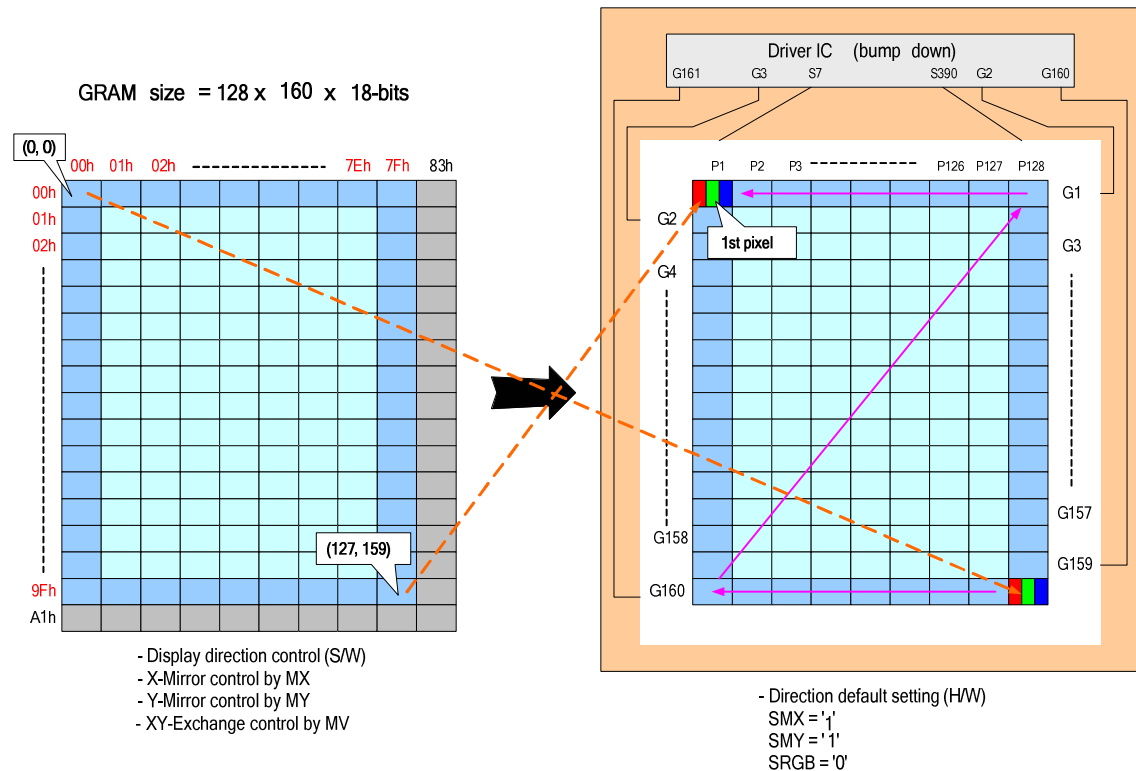

Case2 of Resolution (132RGB x 132) (GM[1:0] = "01")

RAM size=132 x 132 x 18-bit (Used)

Display size = 132RGB x 132

1). Example for SMX=SMY='0'

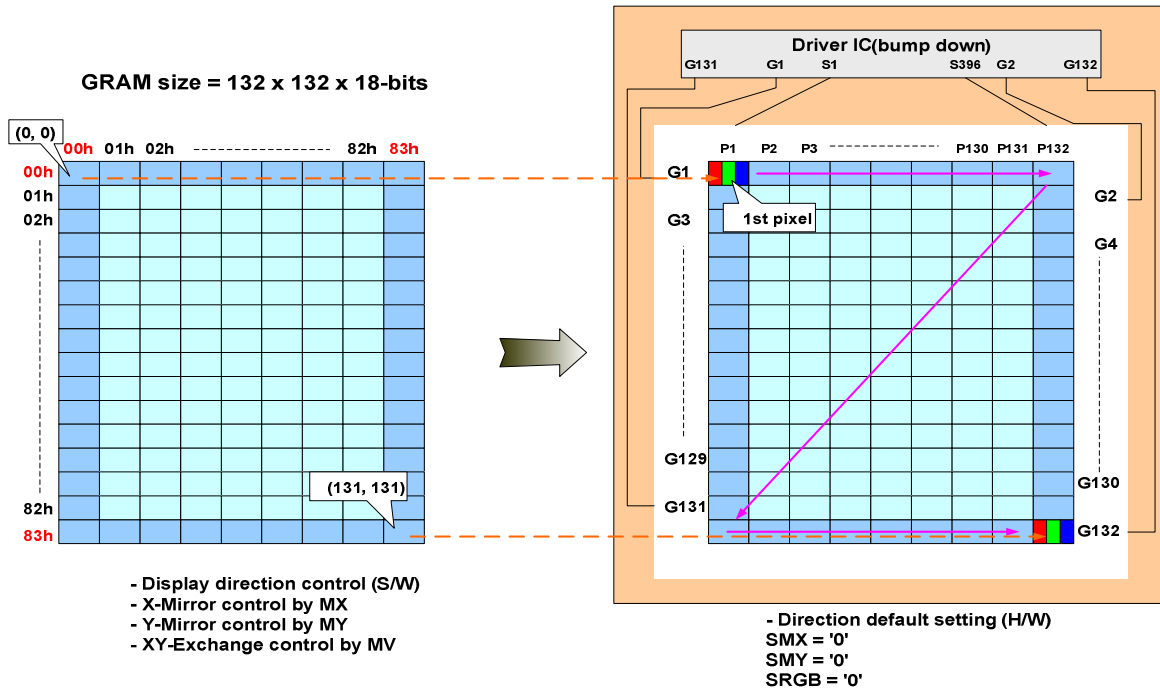

2). Example for SMX=SMY='1'

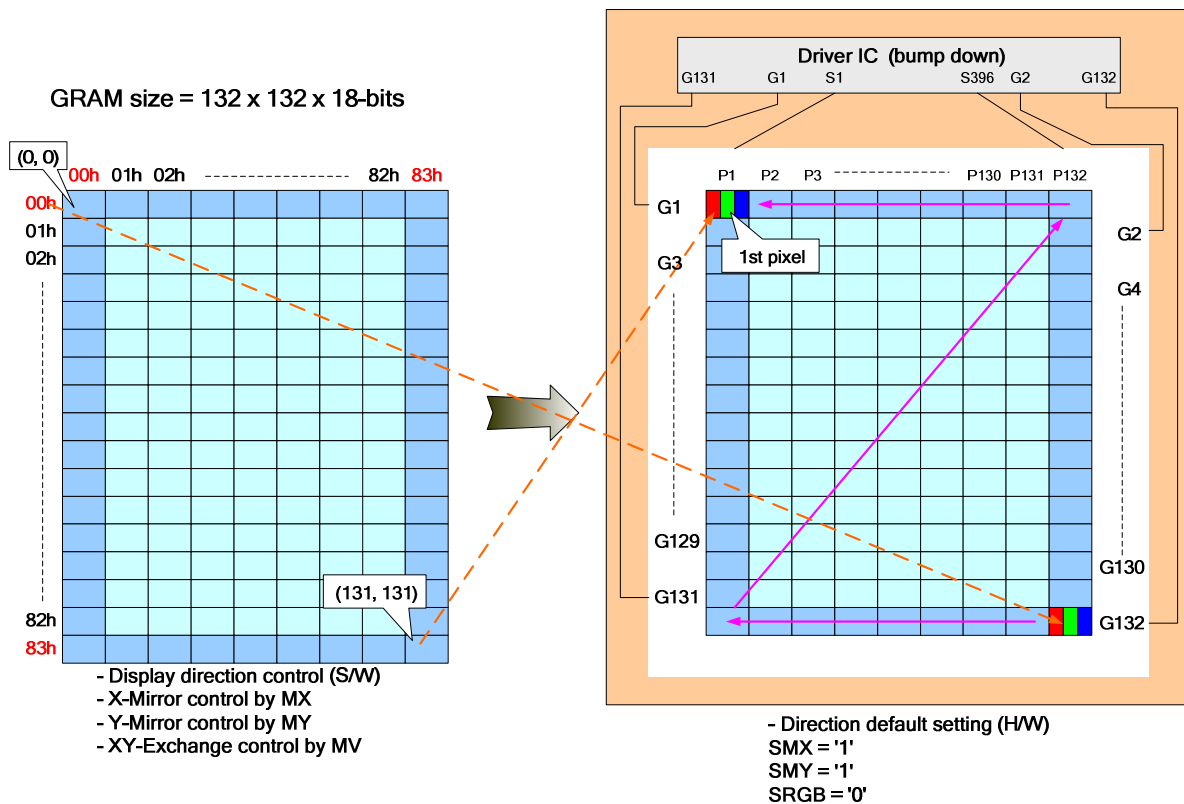

Case3 of Resolution (132RGB x 162) (GM[1:0] = "00")

RAM Size=132 x 162 x 18-bit (Used)

Display Size = 132RGB x 162

1). Example for SMX=SMY='0'

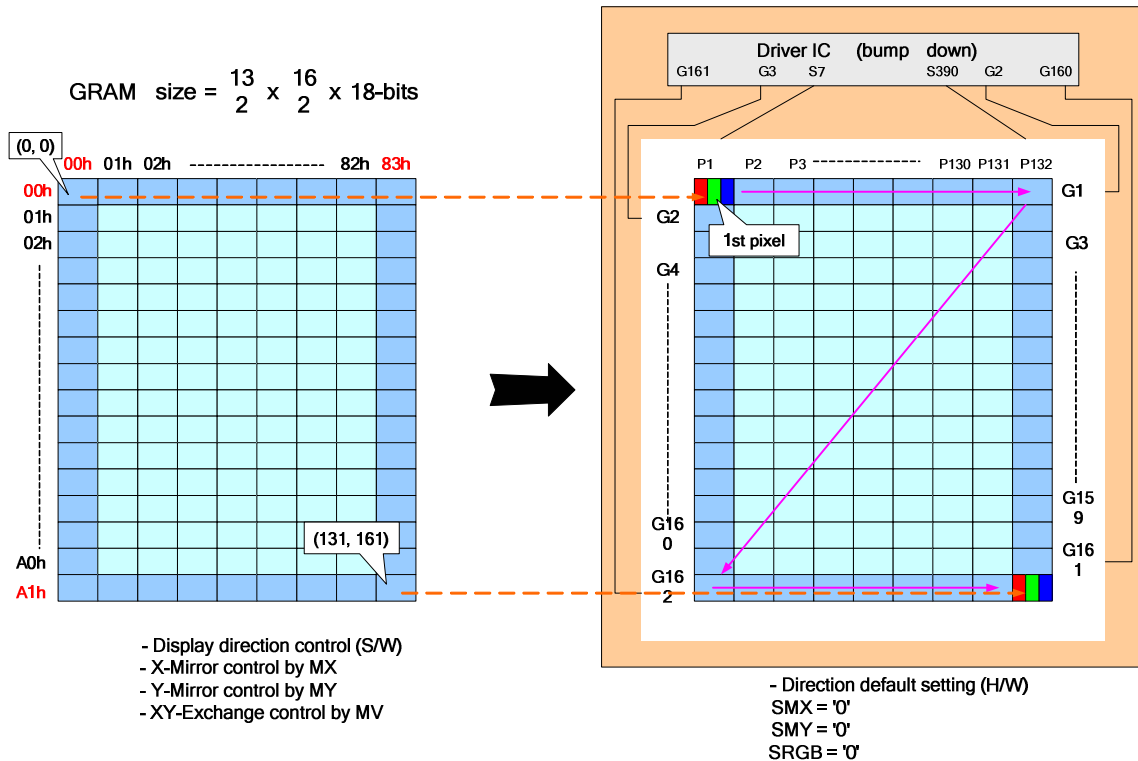

2). Example for SMX=SMY='1'

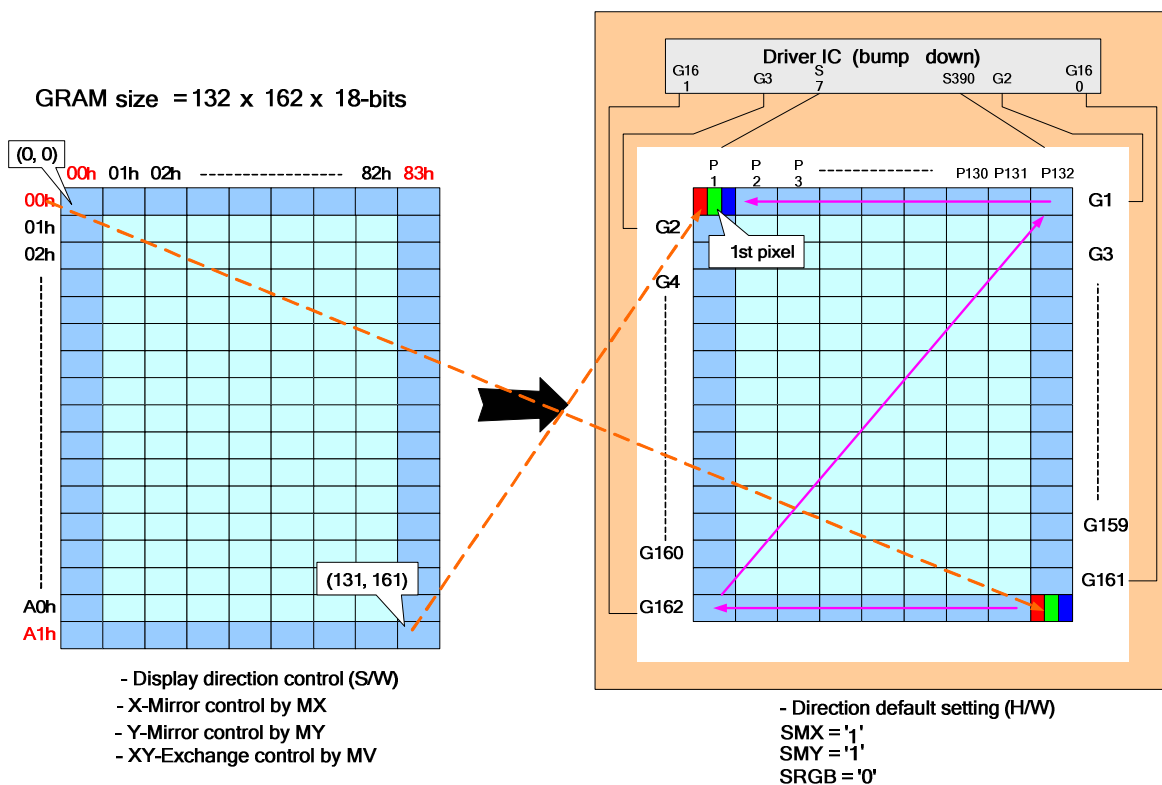

13.3 Microprocessor Interface Applications

13.3.1 8080-Series MCU Interface for 8-bit Data Bus (P68=0, IM2, IM1, IM0="100")

80 Serial MPU 8-Bit Bus

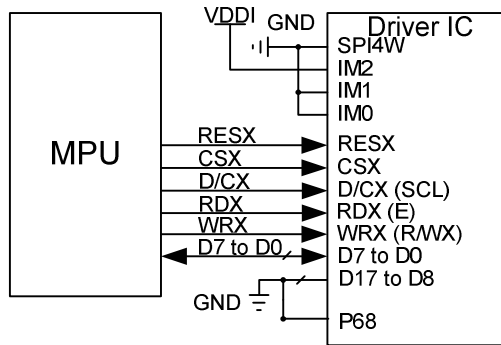

13.3.2 8080-Series MCU Interface for 16-bit Data Bus (P68=0, IM2, IM1, IM0="101")

80 Serial MPU 16-Bit Bus

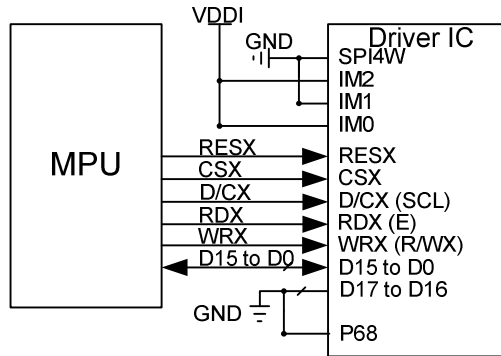

13.3.3 8080-Series MCU Interface for 9-bit Data Bus (P68=0, IM2, IM1, IM0="110")

80 Serial MPU 9-Bit Bus

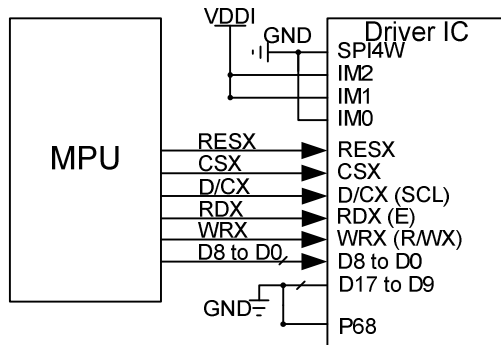

13.3.4 8080-Series MCU Interface for 18-bit Data Bus (P68=0, IM2, IM1, IM0="111")

80 Serial MPU 18-Bit Bus

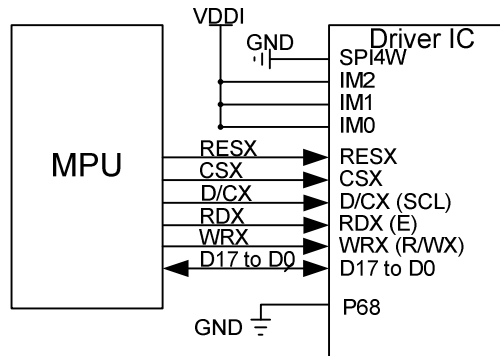

13.3.5 6800-Series MCU Interface for 8-bit Data Bus (P68=1, IM2, IM1, IM0="100")

68 Serial MPU 8-Bit Bus

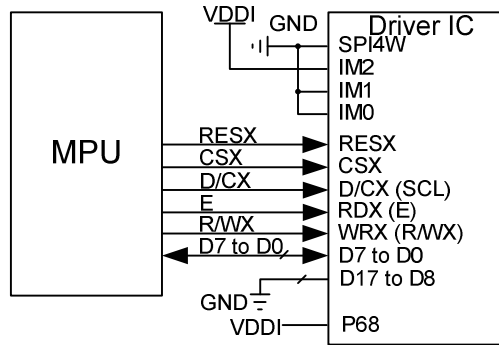

13.3.6 6800-Series MCU Interface for 16-bit Data Bus (P68=1, IM2, IM1, IM0="101")

68 Serial MPU 16-Bit Bus

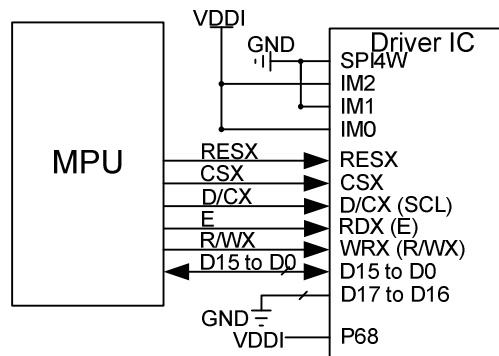

13.3.7 6800-Series MCU Interface for 9-bit Data Bus (P68=1, IM2, IM1, IM0="110")

68 Serial MPU 9-Bit Bus

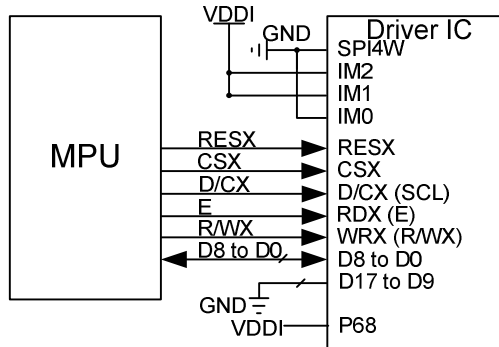

13.3.8 6800-Series MCU Interface for 18-bit Data Bus (P68=1, IM2, IM1, IM0="111")

68 Serial MPU 18-Bit Bus

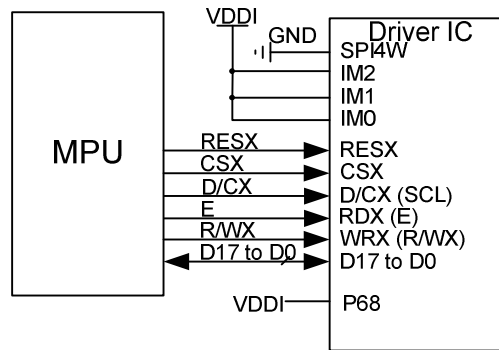

13.3.9 3-Line Serial MCU Interface (IM2, IM1, IM0="000", SPI4W=0)

3-Pin Serial Mode

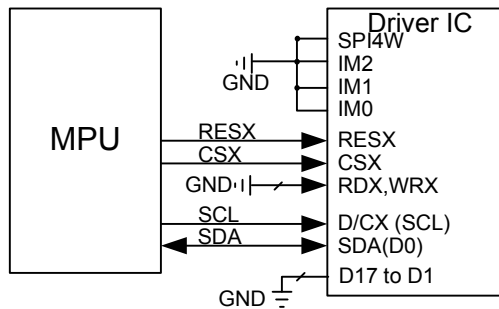

13.3.10 4-Line Serial MCU Interface (IM2, IM1, IM0="000", SPI4W=1)

4-Pin Serial Mode

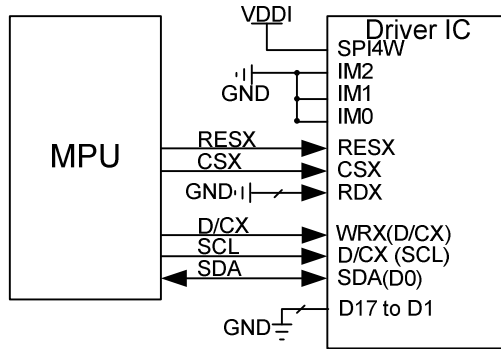

14 Revision History

| ST7735S Specification Revision History | | |
|--|------------|-------------------|
| Version | Date | Description |
| 1.0 | 2011/06/10 | First issue. |
| 1.1 | 2011/11/21 | Modify ID1 Value. |