

1

2

3

4

A

A

B

B

C

C

D

D

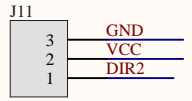
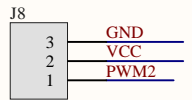
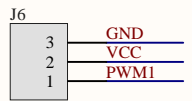
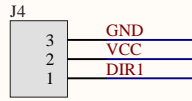
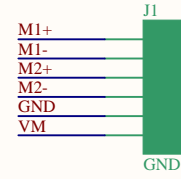
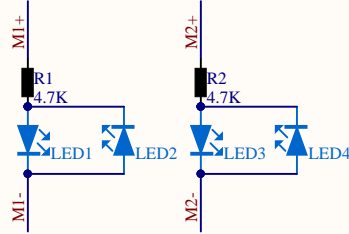

Title: Expansion Shield for Driver(TB6612)	SKU: 019.00256
Drawn: Lf-CD	Revision: V1.0
Page: 1 of 1	Size: A4
Date: 2017/11/17	Time: 14:23:27

1

2

3

4

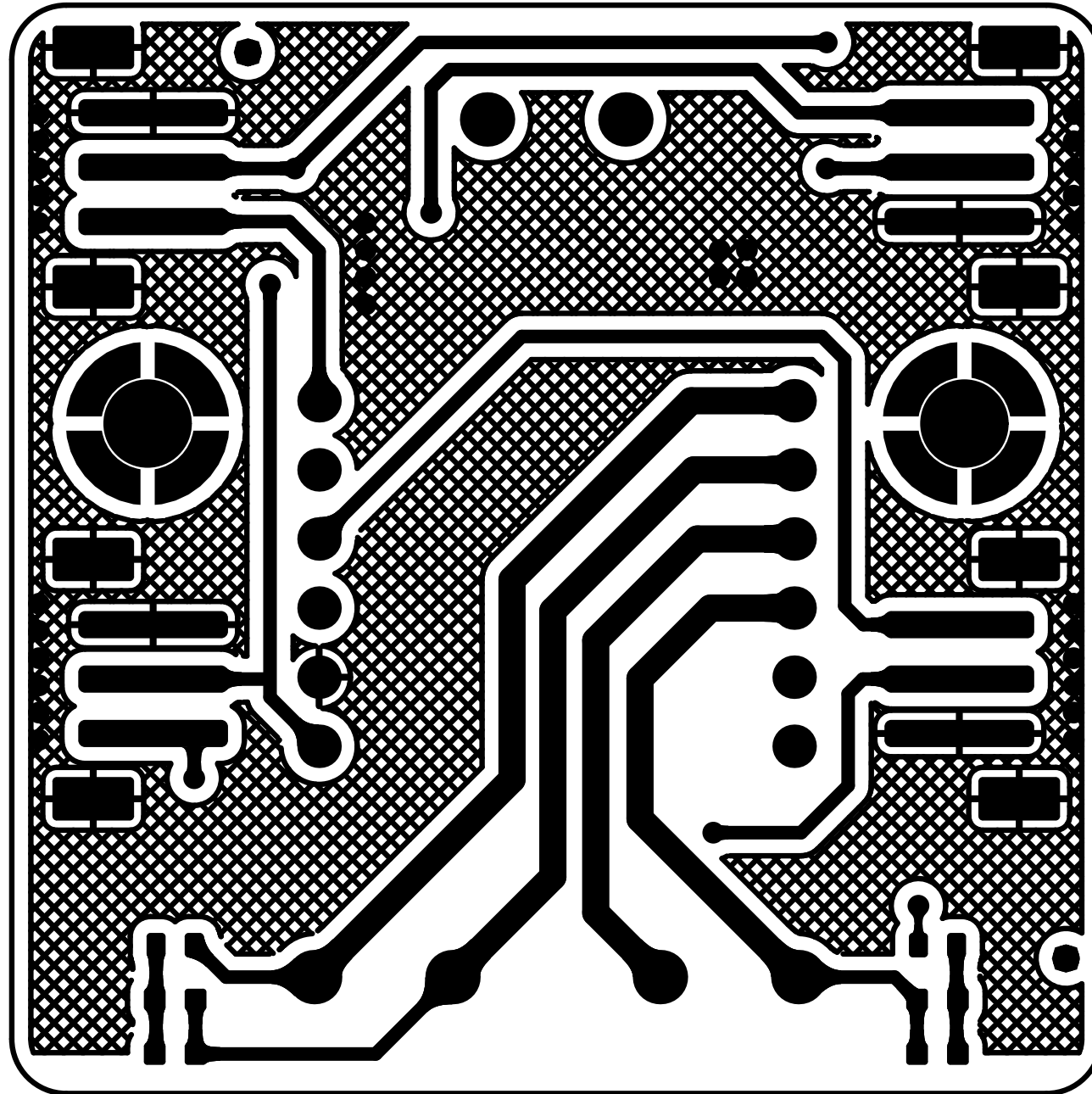

PCB Information	Name:019.00256[V1.0]	Thickness: 1.6mm
Engineer:lf CO	Top SolderMask: Black	Bottom SolderMask: Black
Date:20171117	Top Silkscreen: White	Bottom Silkscreen: White

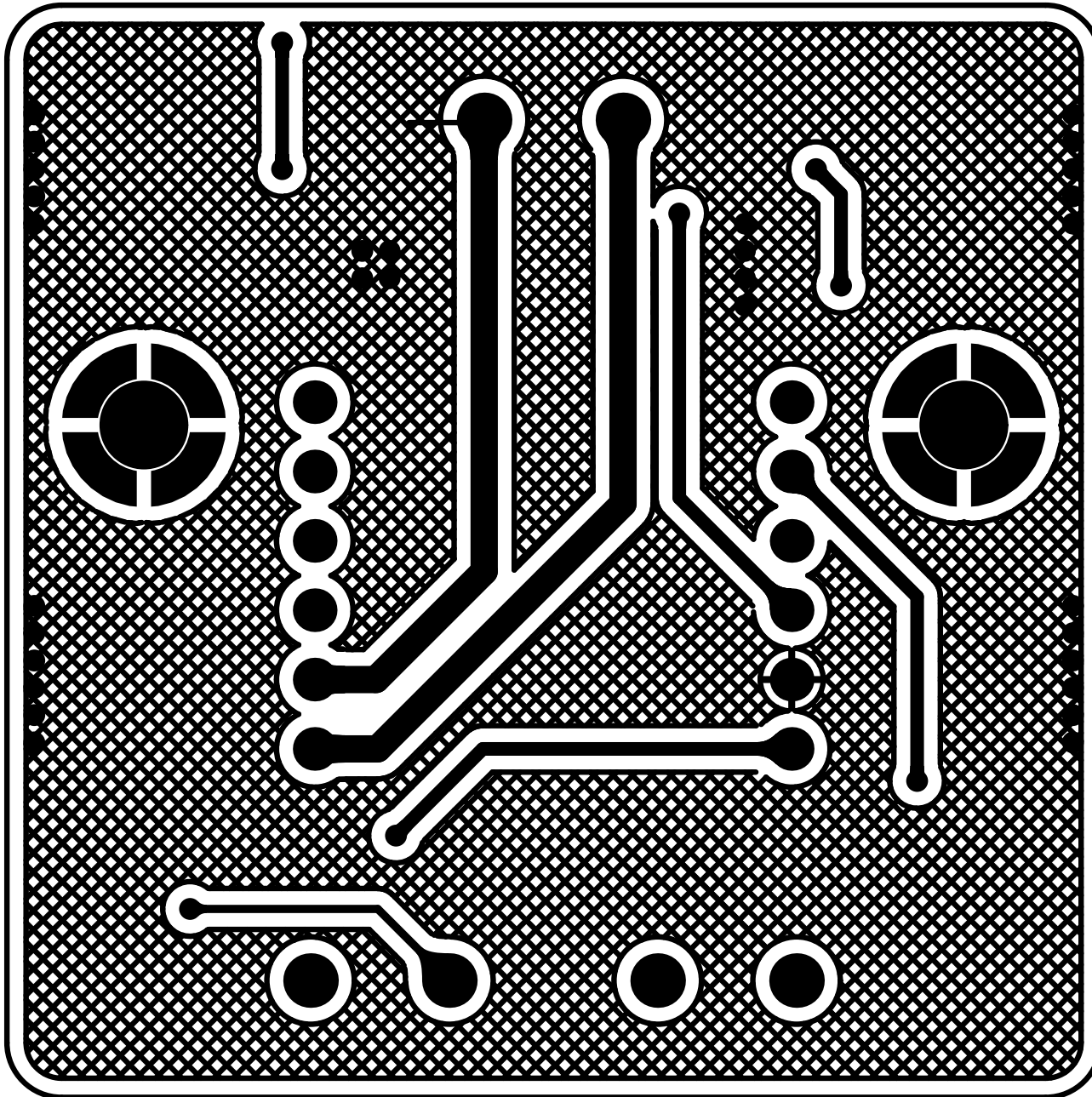

PCB Information	Name:019.00256(V1.0)	Thickness: 1.6mm
Engineer: lf CD	Top SolderMask: Black	Bottom SolderMask: Black
Date:2017/11/7	Top Silkscreen: White	Bottom Silkscreen: White

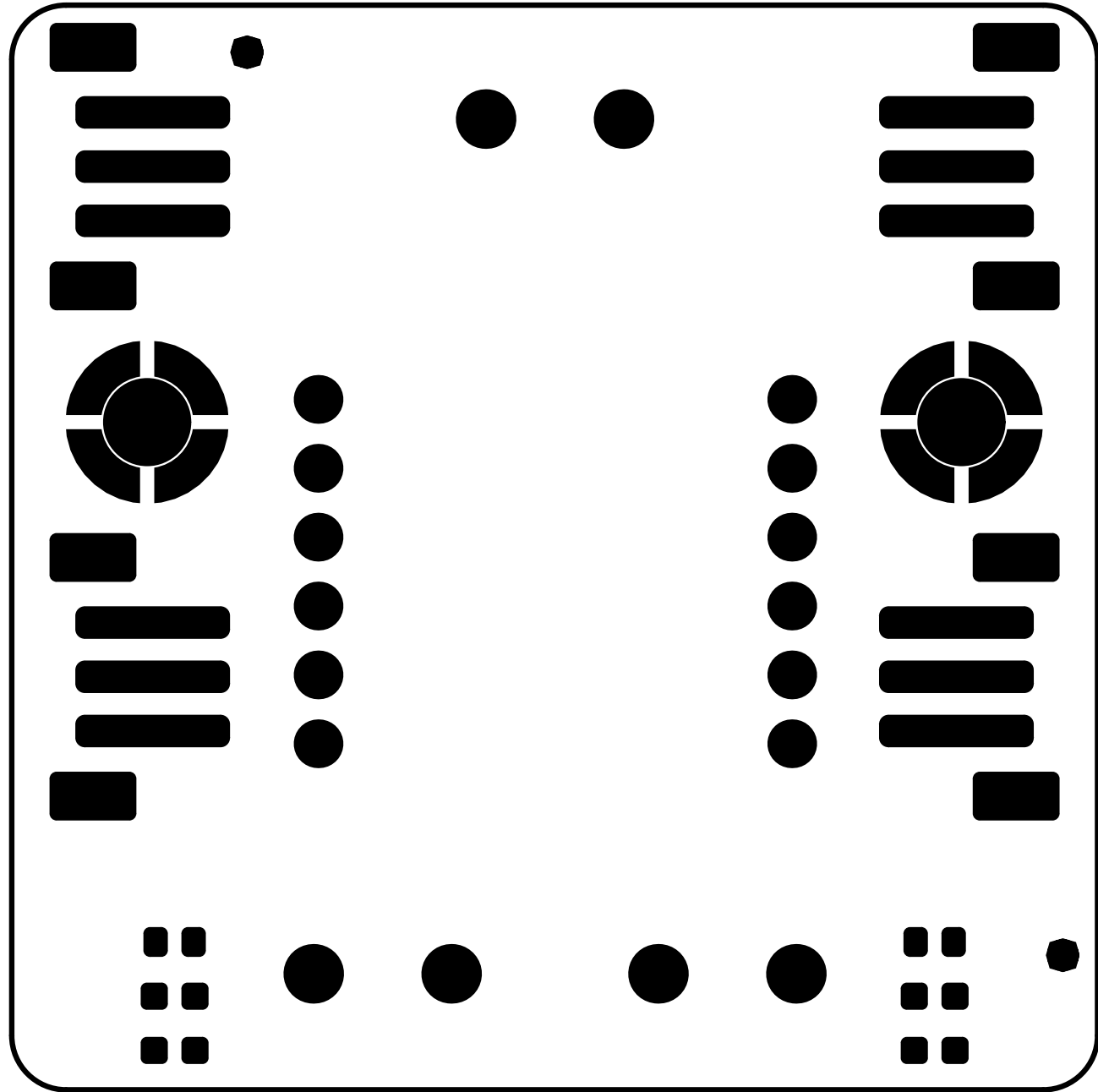

PCB Information	Name: 019.00256[V1.0]	Thickness: 1.6mm
Engineer: f CO	Top SolderMask: Black	Bottom SolderMask: Black
Date: 20171117	Top Silkscreen: White	Bottom Silkscreen: White

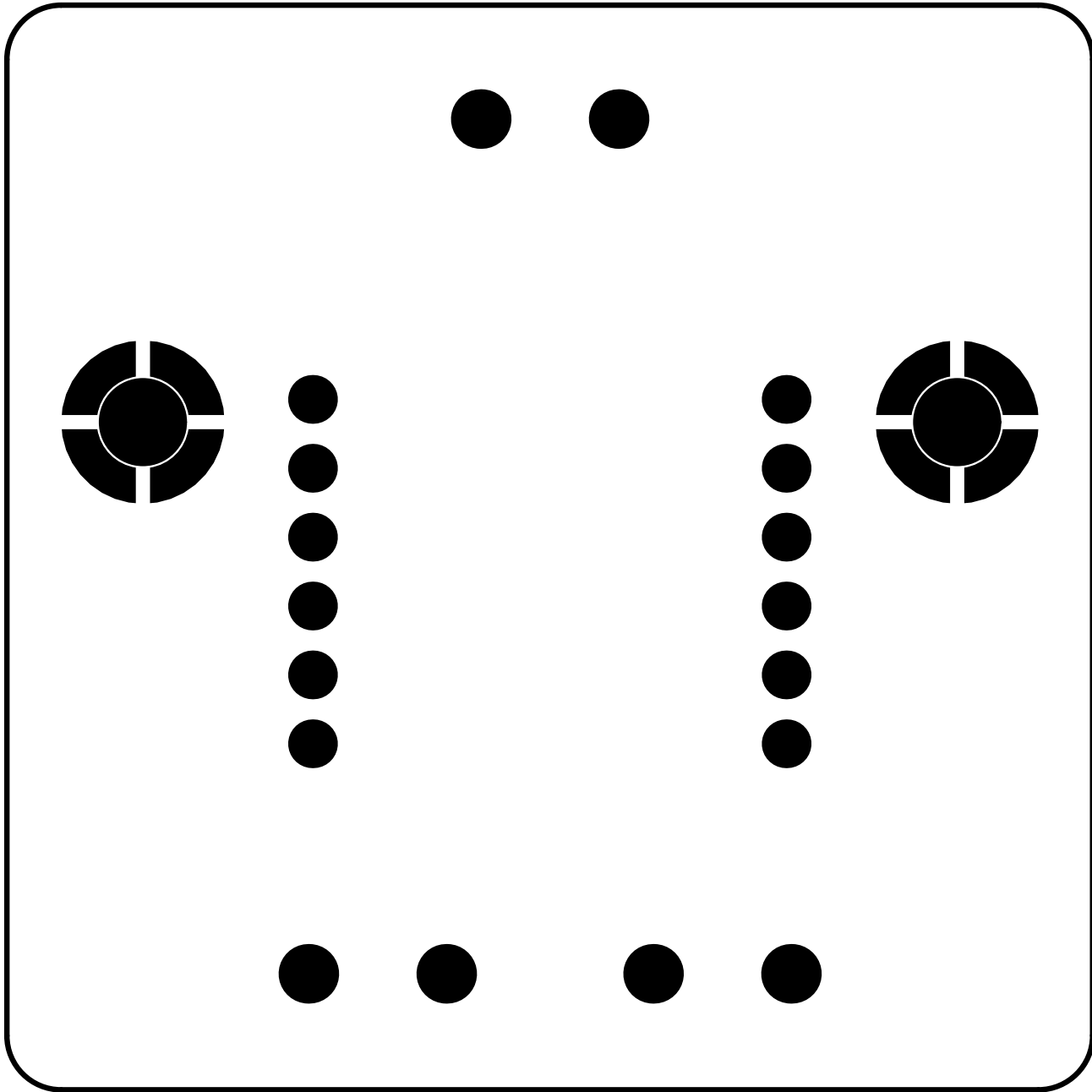

PCB Information	Name:019.00256[V1.0]	Thickness: 1.6mm
Engineer: lf CD	Top SolderMask: Black	Bottom SolderMask: Black
Date:s2017/11/7	Top Silkscreen: White	Bottom Silkscreen: White

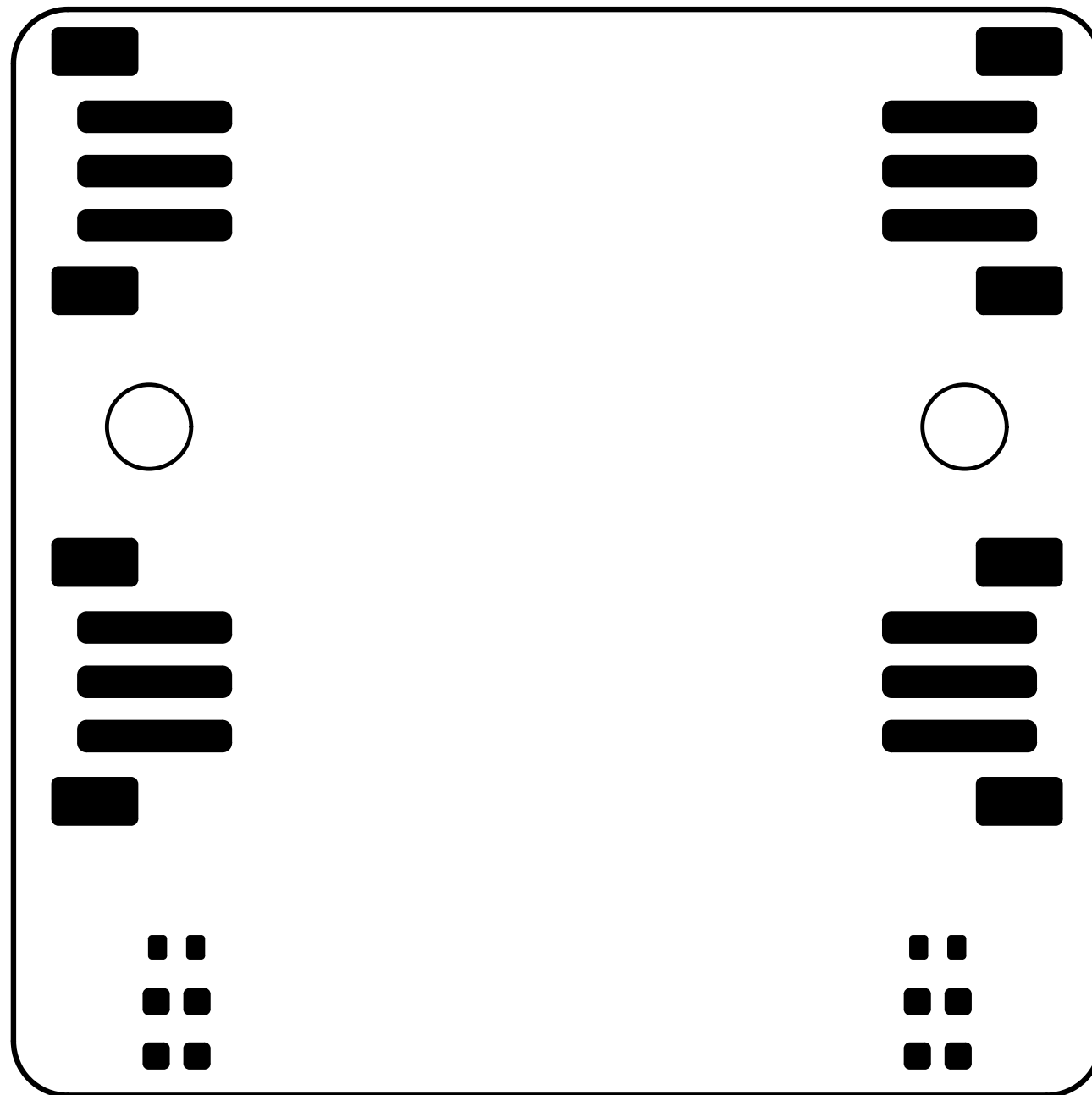

PCB Information	Name:019.00256[V1.0]	Thickness: 1.6mm
Engineer:f CD	Top SolderMask: Black	Bottom SolderMask: Black
Date:20171117	Top Silkscreen: White	Bottom Silkscreen: White

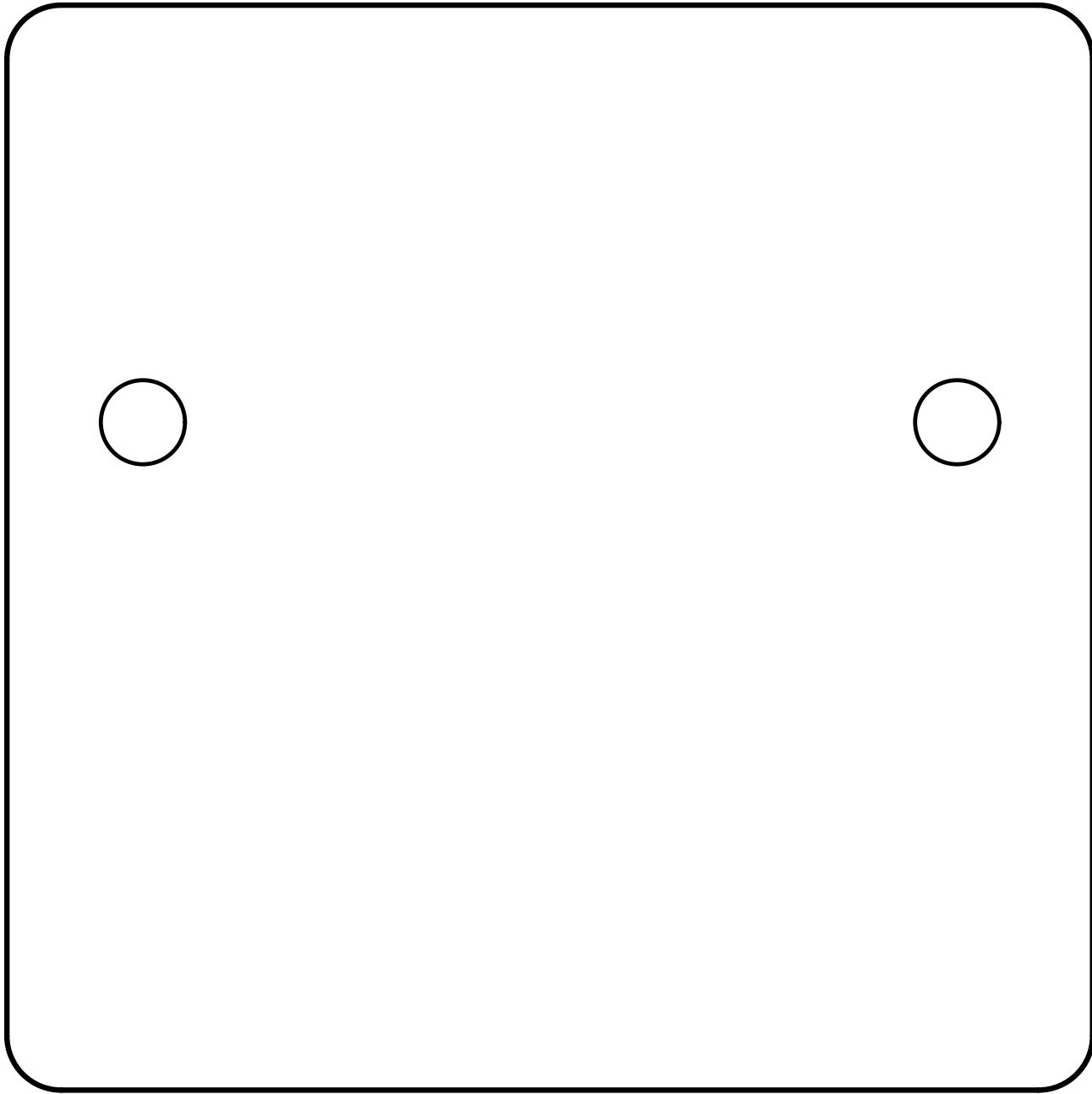

PCB Information	Name:019.00256(V1.0)	Thickness:1.6mm
Engineer: lf_CD	Top SolderMask: Black	Bottom SolderMask: Black
Date:2017/11/7	Top Silkscreen: White	Bottom Silkscreen: White

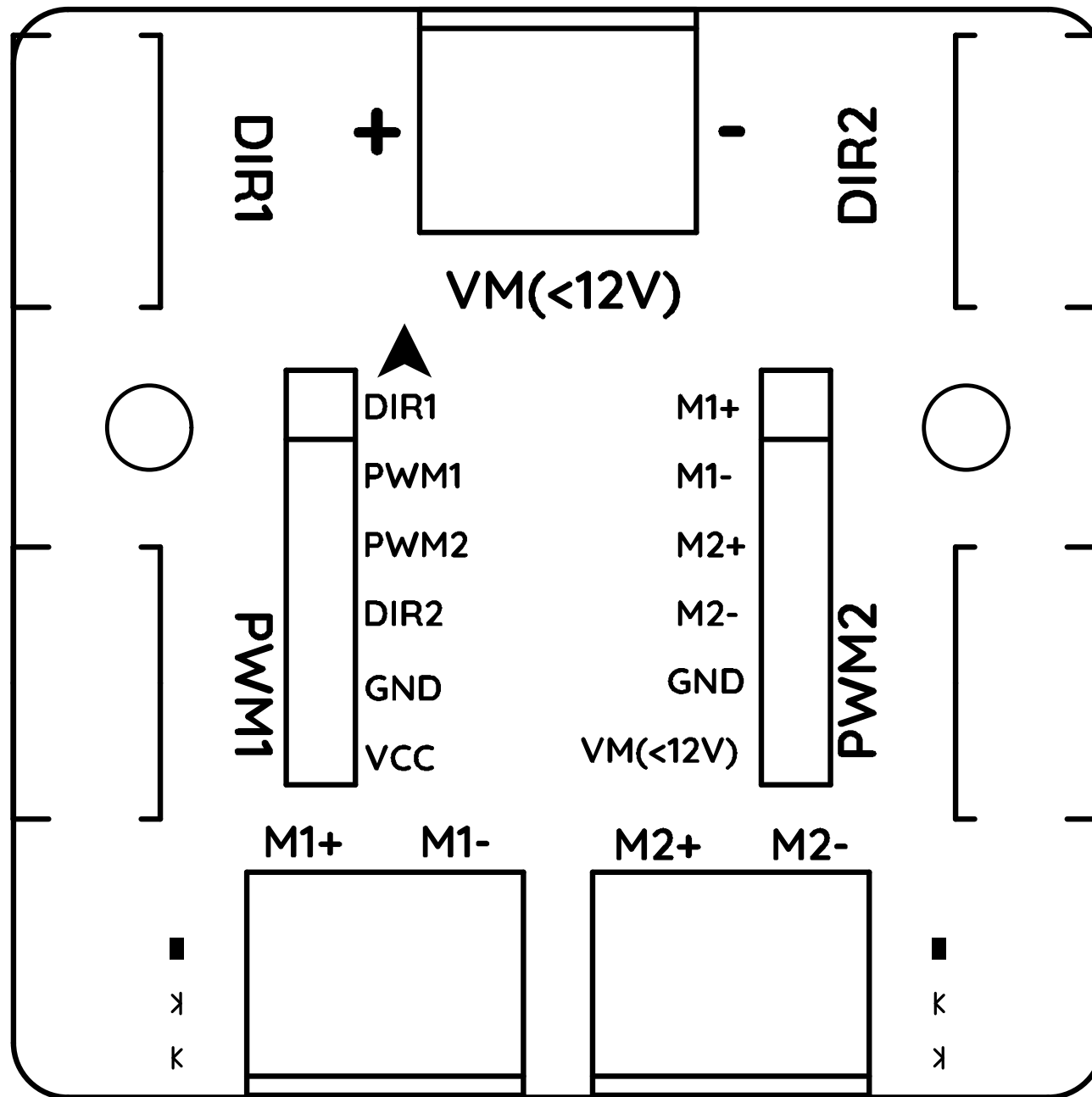

PCB Information	Name:DIR.00256[V1.0]	Thickness: 1.6mm
Engineer:f CD	Top SolderMask: Black	Bottom SolderMask: Black
Date:20171117	Top Silkscreen: White	Bottom Silkscreen: White

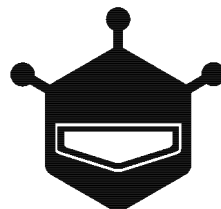
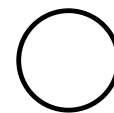
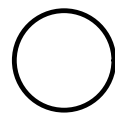

DFROBOT

Expansion Shield for Driver(TB6612) V1.0

PCB Information	Name:019.00256[V1.0]	Thickness: 1.6mm
Engineer: lf_CD	Top SolderMask: Black	Bottom SolderMask: Black
Date:s2017/11/7	Top Silkscreen: White	Bottom Silkscreen: White

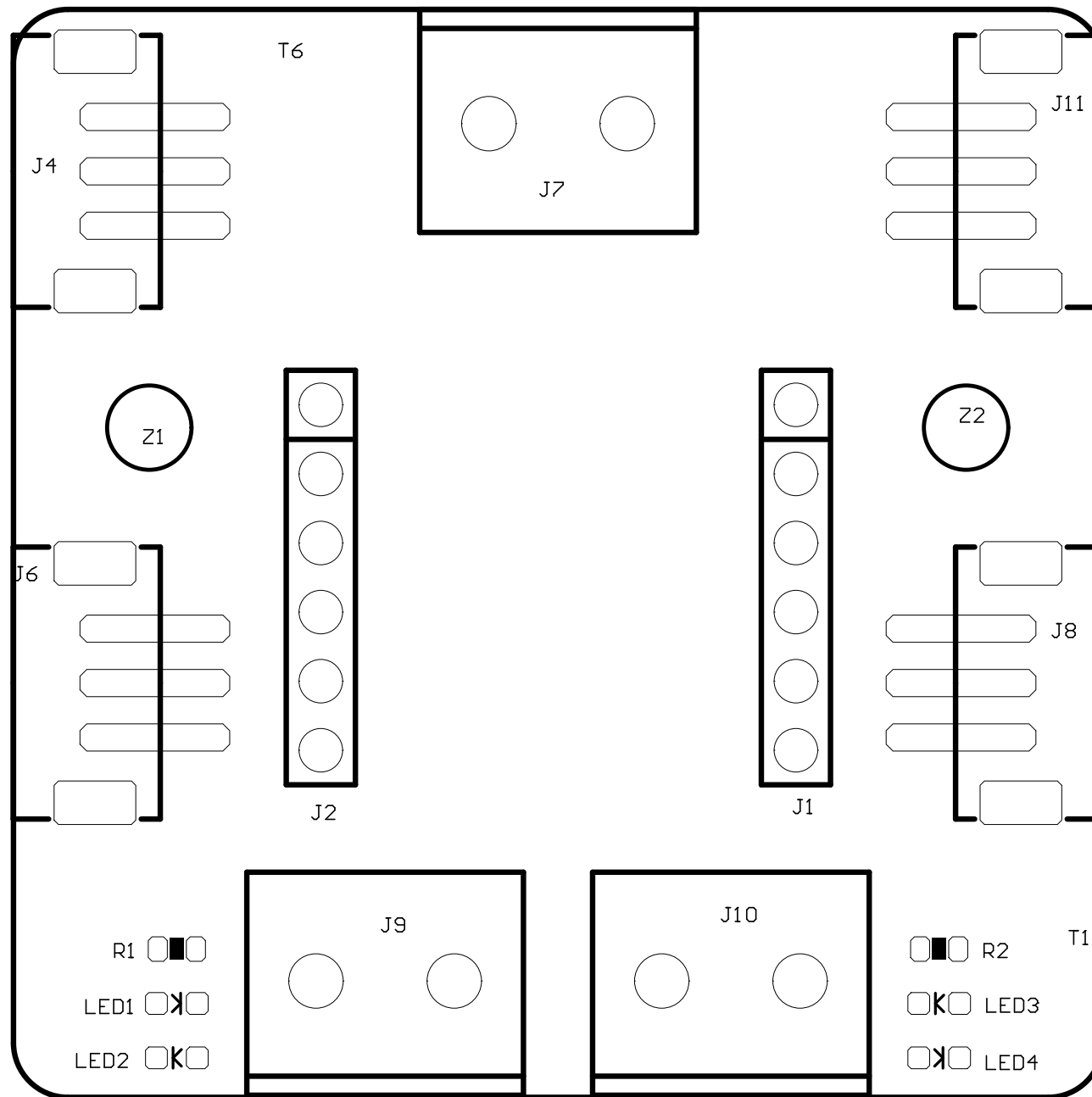

PCB Information		
Name: 019.00256[V1.0]	Thickness: 1.6mm	
Engineer: f CO	Top SolderMask: Black	Bottom SolderMask: Black
Date: 2017/11/7	Top Silkscreen: White	Bottom Silkscreen: White

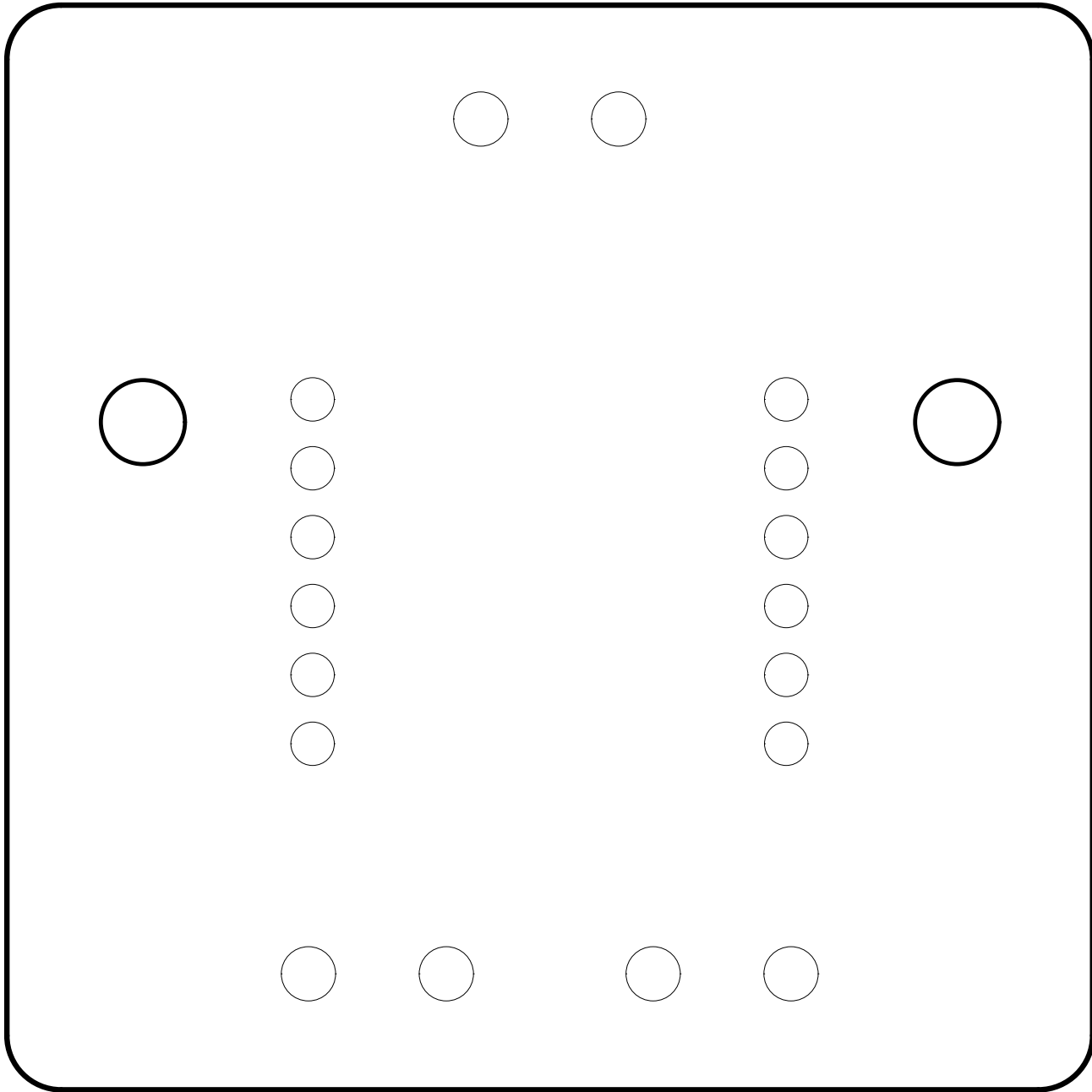

PCB Information	Name:019.00256[V1.0]	Thickness: 1.6mm
Engineer: lf CD	Top SolderMask: Black	Bottom SolderMask: Black
Date:s2017/11/7	Top Silkscreen: White	Bottom Silkscreen: White

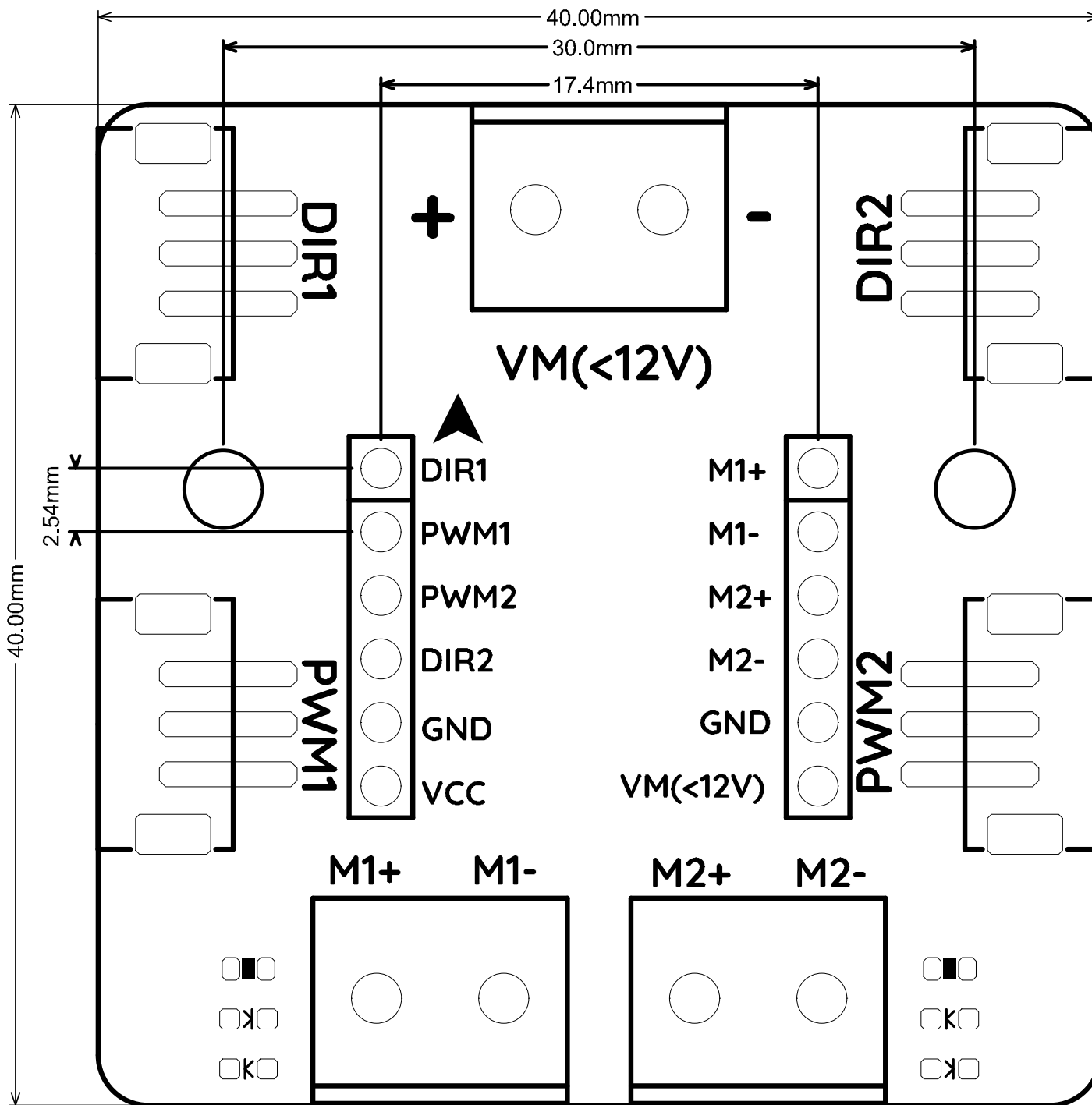

PCB Information		Name: D19.00256[V1.0]	Thickness: 1.6mm
Engineer: f CD	Top SolderMask: Black	Bottom SolderMask: Black	
Date: 2017/11/7	Top Silkscreen: White	Bottom Silkscreen: White	

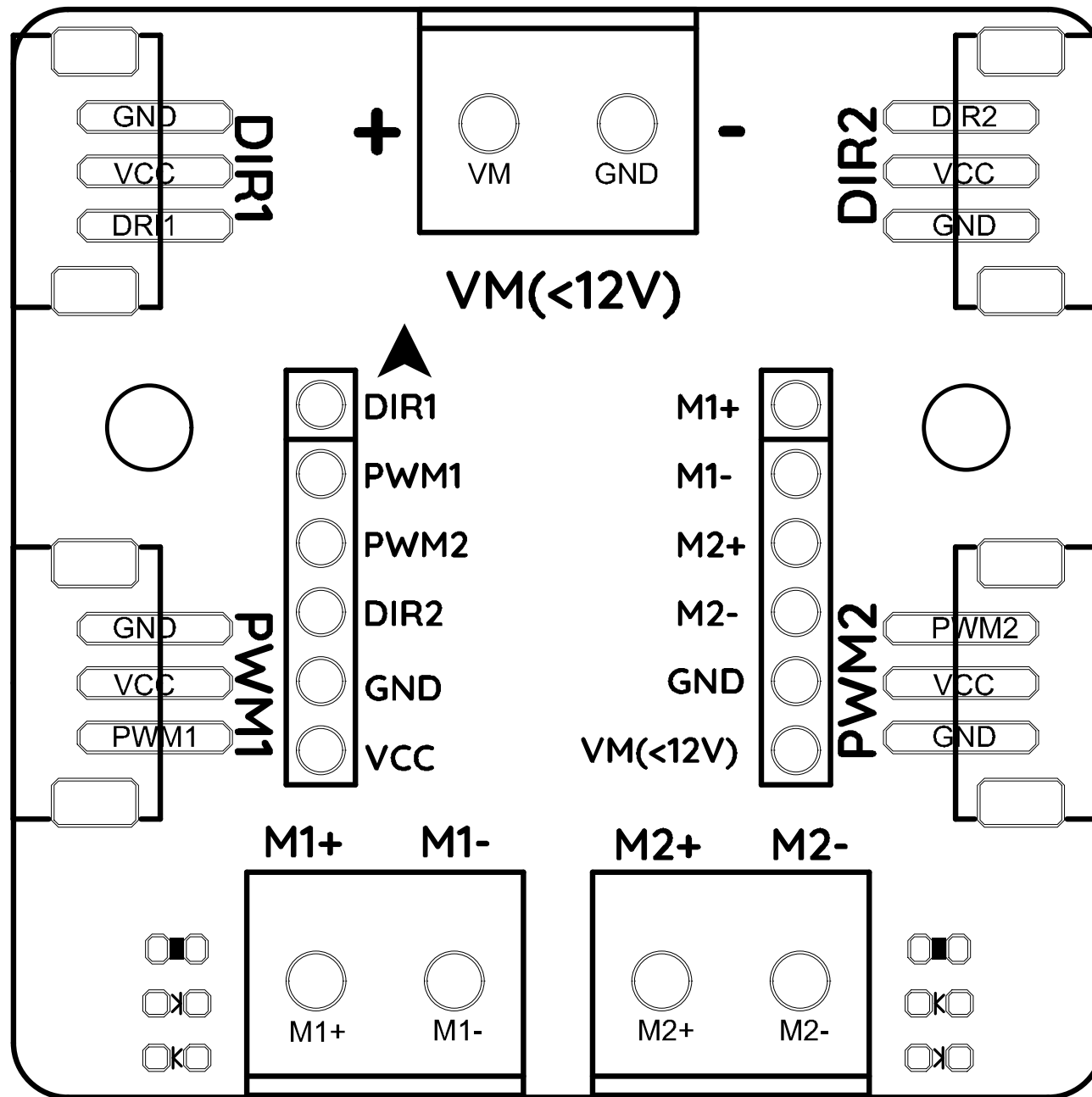

PCB Information	Name: D19.00256[V1.0]	Thickness: 1.6mm
Engineer: f CO	Top SolderMask: Black	Bottom SolderMask: Black
Date: 20171117	Top Silkscreen: White	Bottom Silkscreen: White

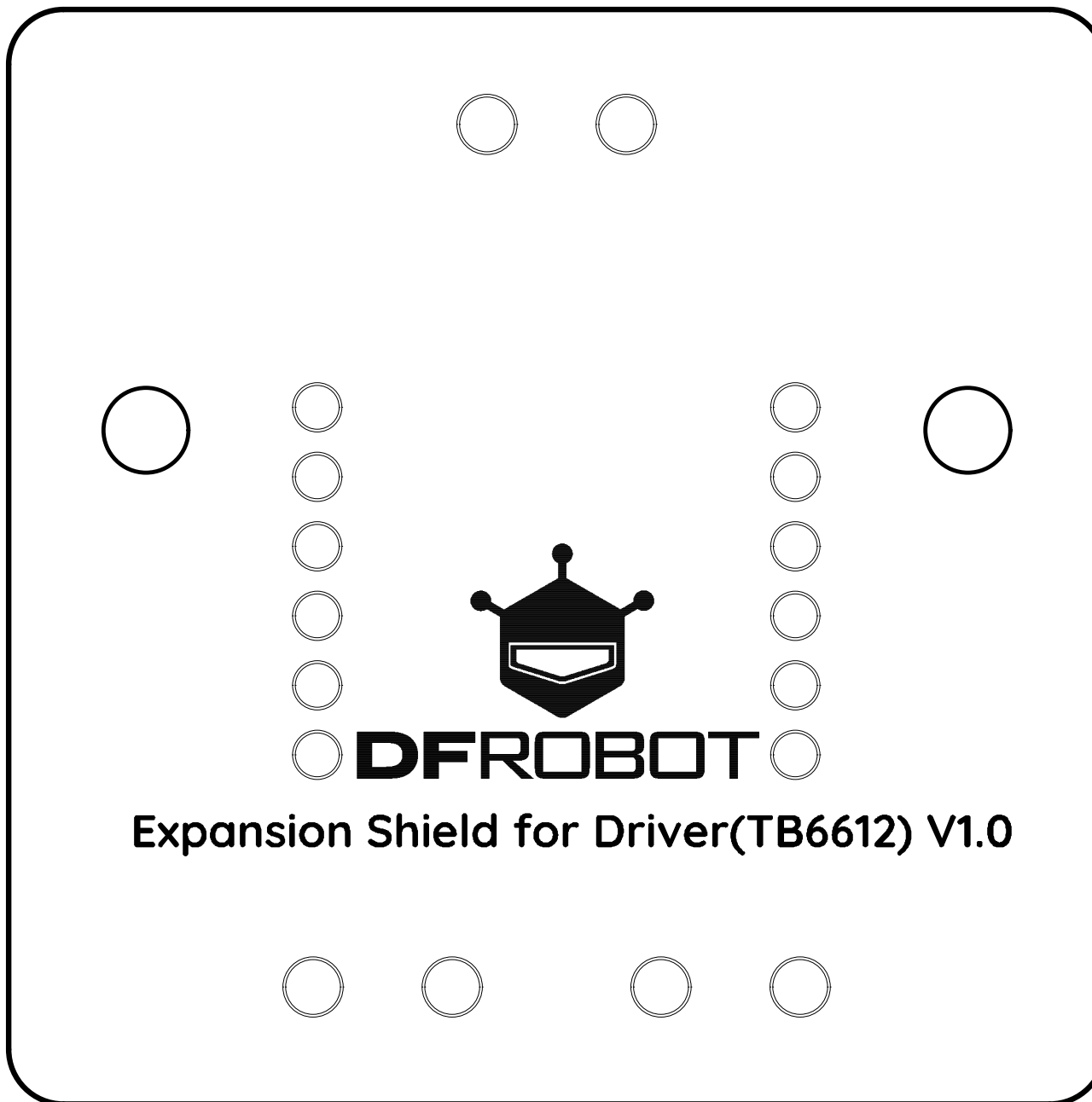

Expansion Shield for Driver(TB6612) V1.0

PCB Information	Name:019.00256[V1.0]	Thickness: 1.6mm
Engineer: lf CD	Top SolderMask: Black	Bottom SolderMask: Black
Date:s2017/11/7	Top Silkscreen: White	Bottom Silkscreen: White