

# HCR-Mobile Robot Platform (Omni-Directional)

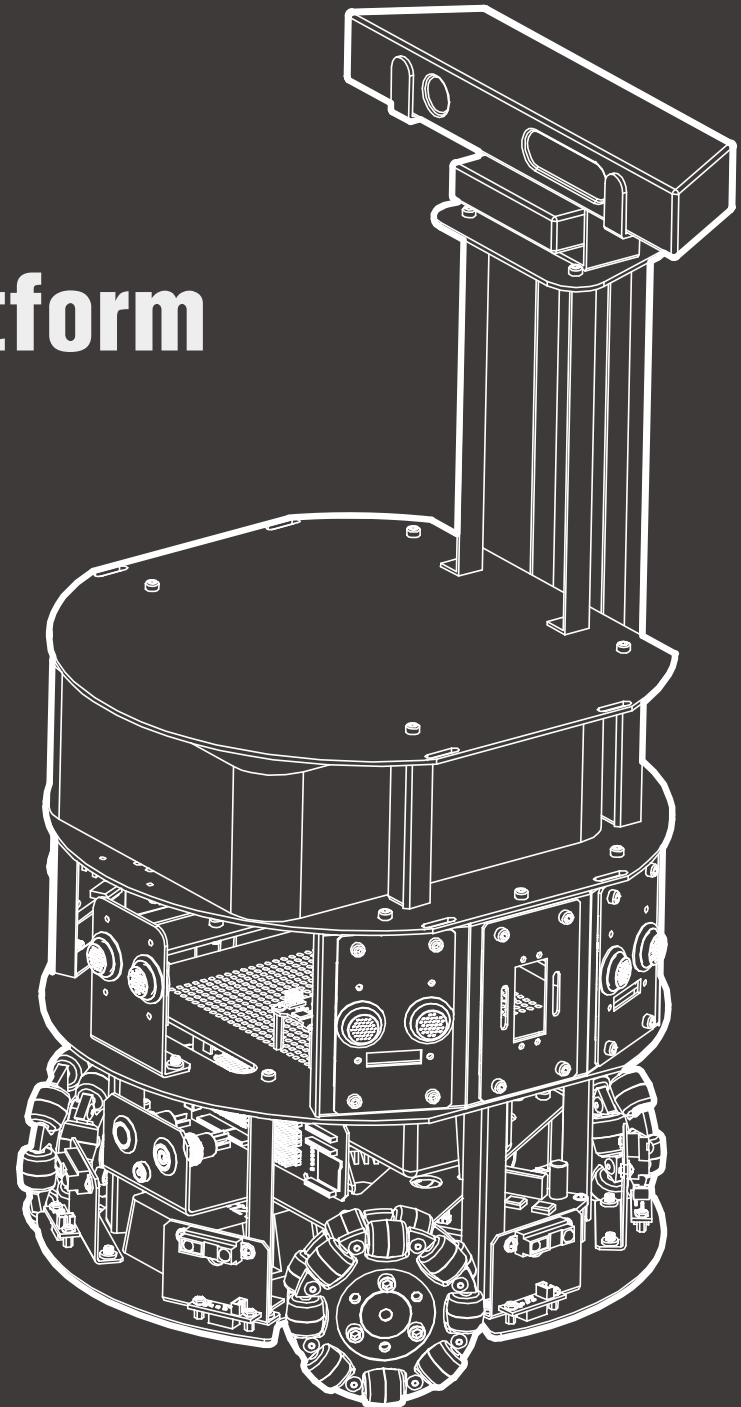

# Essential Parts

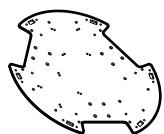

**A1** x1



**A2** x3



**A3** x3



**A4** x3



**A5** x6

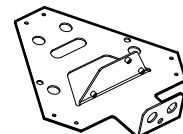

**A6** x1



**A7** x2



**A8** x1



**A9** x1



**A10** x1



**A11** x1



**A12** x6

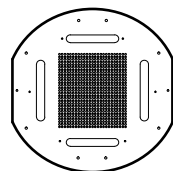

**A13** x1

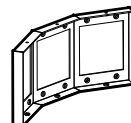

**A14** x2

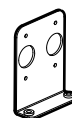

**A15** x2

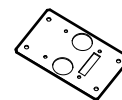

**A16** x4

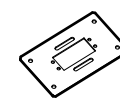

**A17** x2

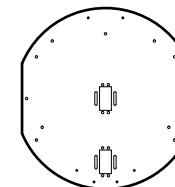

**A18** x1



**A19** x4

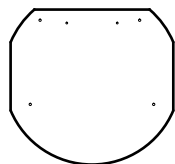

**A20** x1



**A21** x2



**A22** x2



**A23** x1

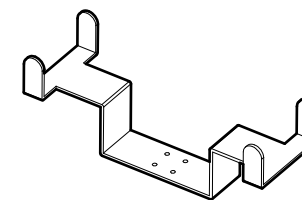

**A24** x1

# Fastenings



**B1** x72  
M3x6mm  
Pan Head Screws



**B2** x96  
M4x10mm  
Inner Hexagon Screw



**B3** x3  
M4  
Nut



**B4** x8  
M5x12mm  
Pan Head Machine Screw



**B5** x12  
M6x12mm  
Inner Hexagon Screw



**B6** x12  
M6  
Flat Washer



**B7** x12  
M6  
Split Lock Washer



**B8** x12  
M6  
Nut

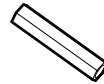

**B9** x4  
M3x20mm  
Standoff



**B10** x12  
M3x6mm  
Standoff



**B11** x22  
M3  
Nut



**B12** x8  
M3  
Nylon Flat Washer



**B13** x10  
M3x22mm  
Pan Head Machine Screw

# Optional Accessories

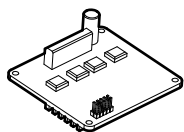

**C1** x2



**C2** x1

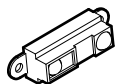

**C3** x6



**C4** x6

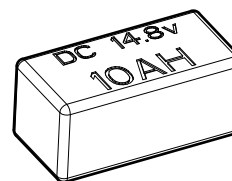

**C5** x1

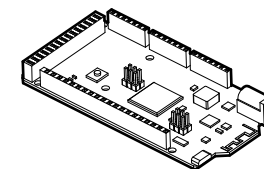

**C6** x1

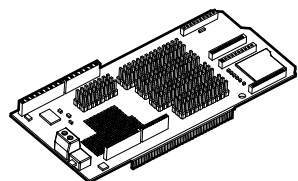

**C7** x1

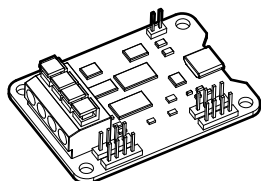

**C8** x1

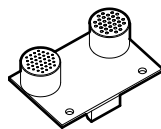

**C9** x6



**C10** x12

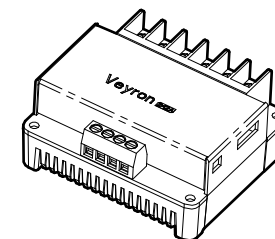

**A11** x2

# Tools List

<b>Essential Tools</b>	Multi-Purpose Screw	Open Spanner	Allen Wrench
<b>Optional Tool</b>	Electric Soldering Iron	Wire Stripper	Piler

# 1

## Mount Motor Brackets

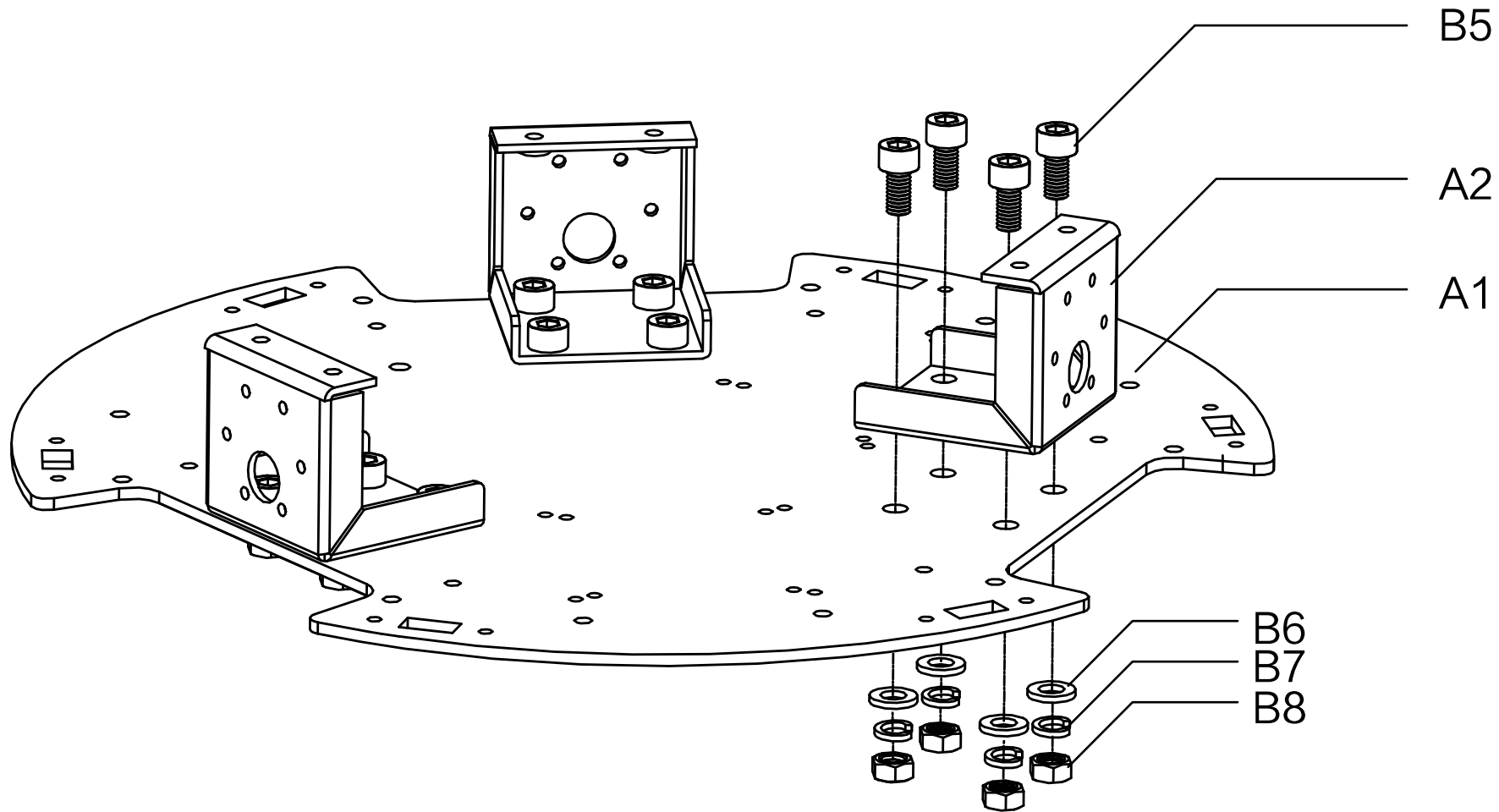

The vertical plane of the motor mount (A2) should strictly match the edge of the base (A1) to ensure further installation of A6.

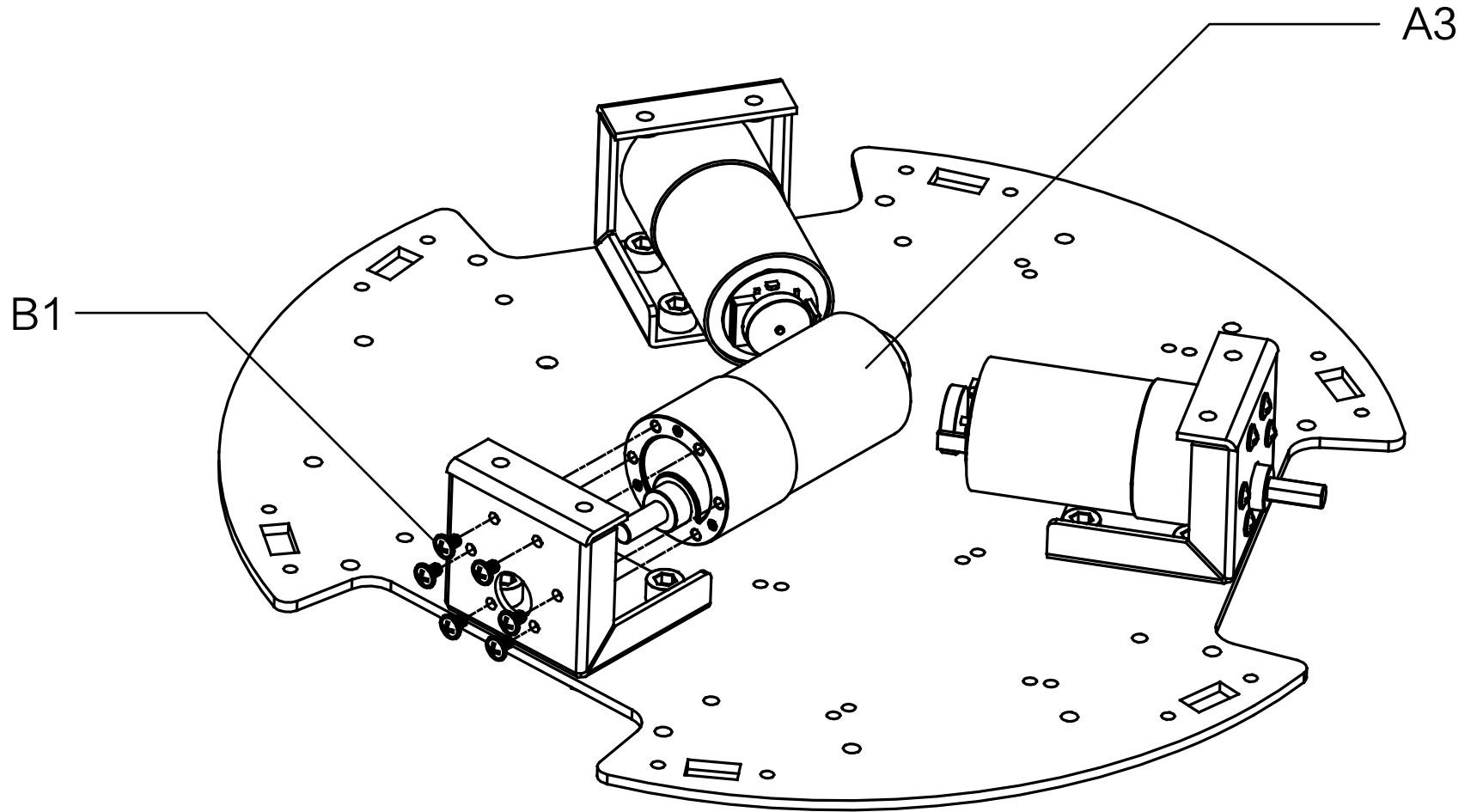

### 3 Install Omni-Wheels

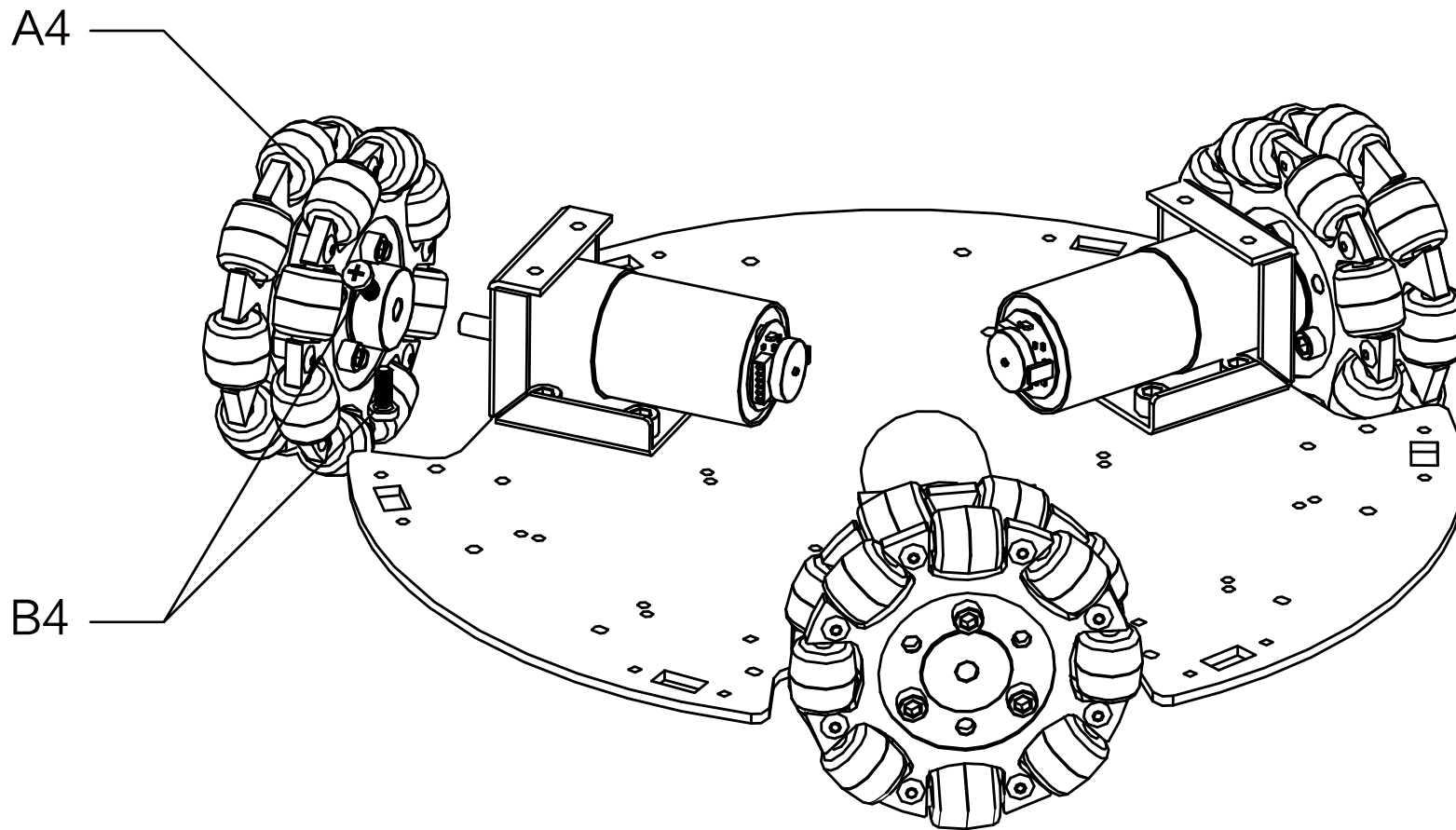



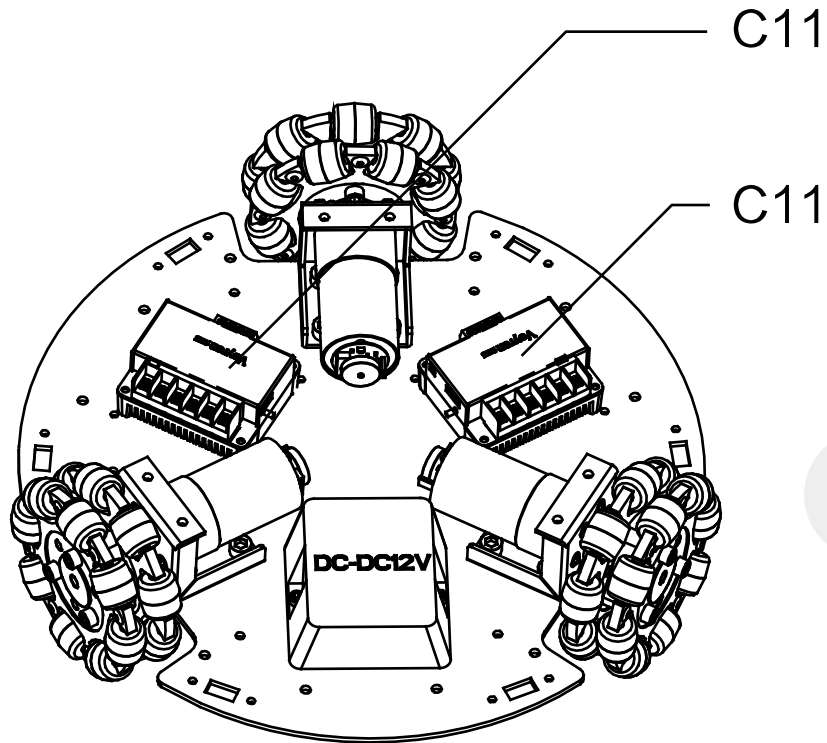

OR

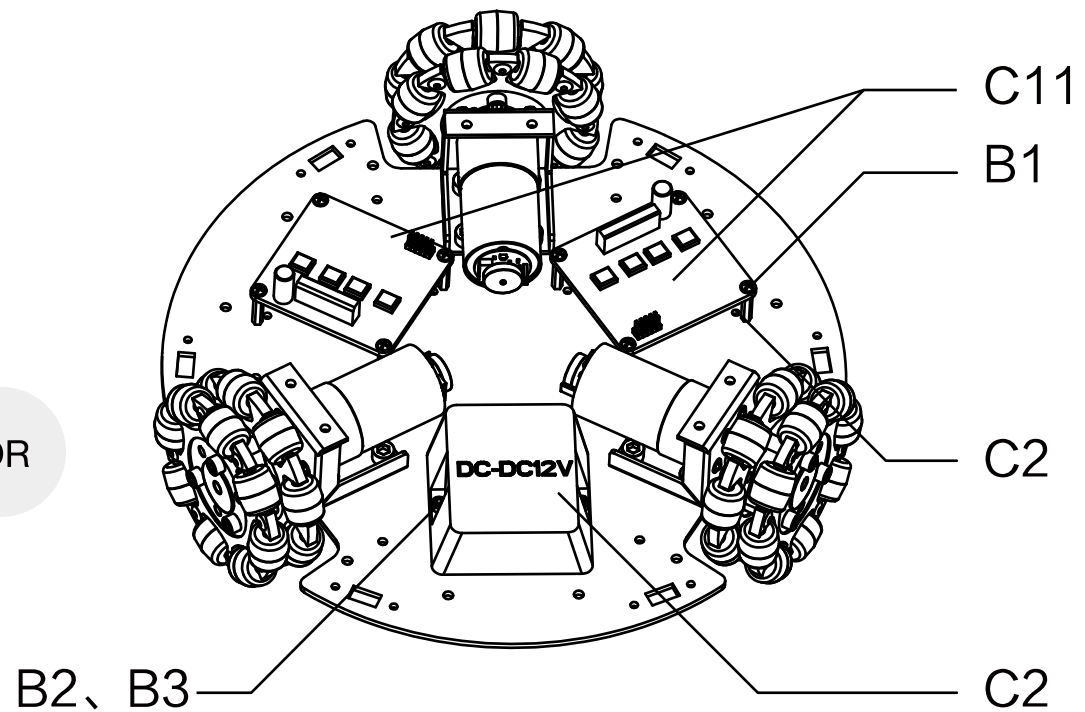

C11(Veyron 12A motor drive)  
Use M3x25mm screws(B14) Secure with M3 nuts(B3)

B1 ( Use M3\*6 Screws to connect both sides of the secure standoff )  
B2,B3(secure with M4 nuts from bottom side)

# 5

## Install Infrared Brackets

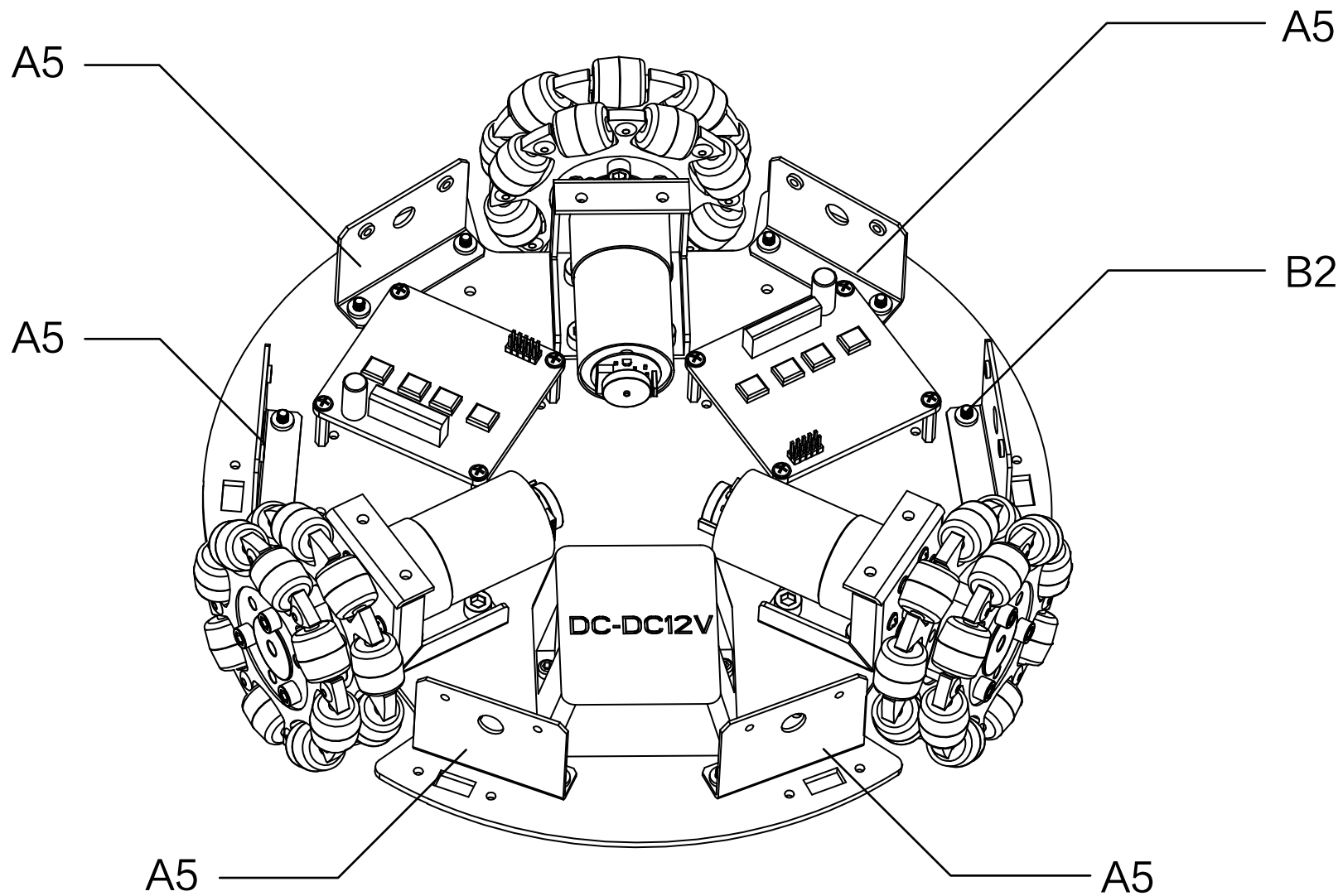

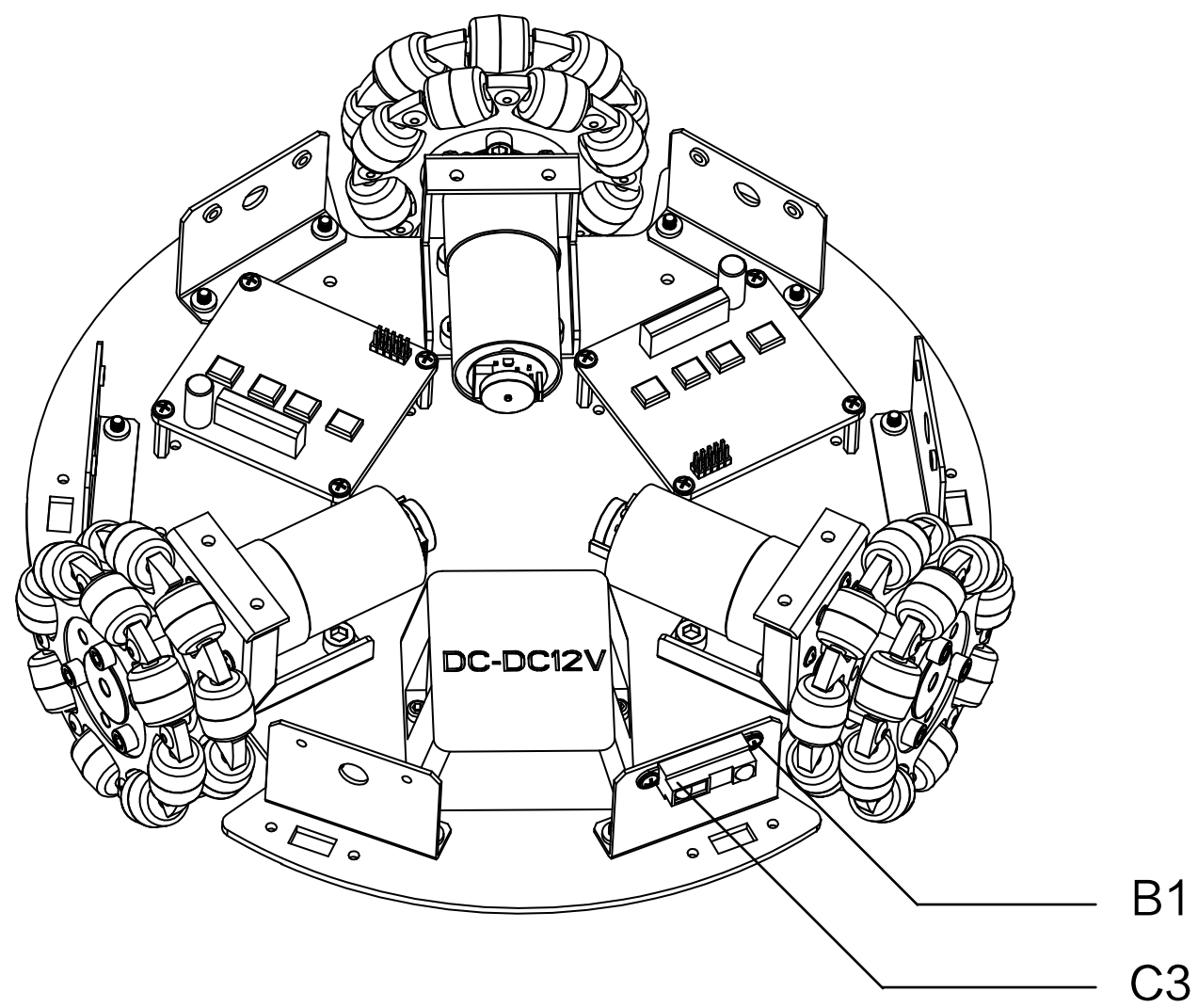

# 7

## Install Anti-Drop Sensors(Optional Parts)

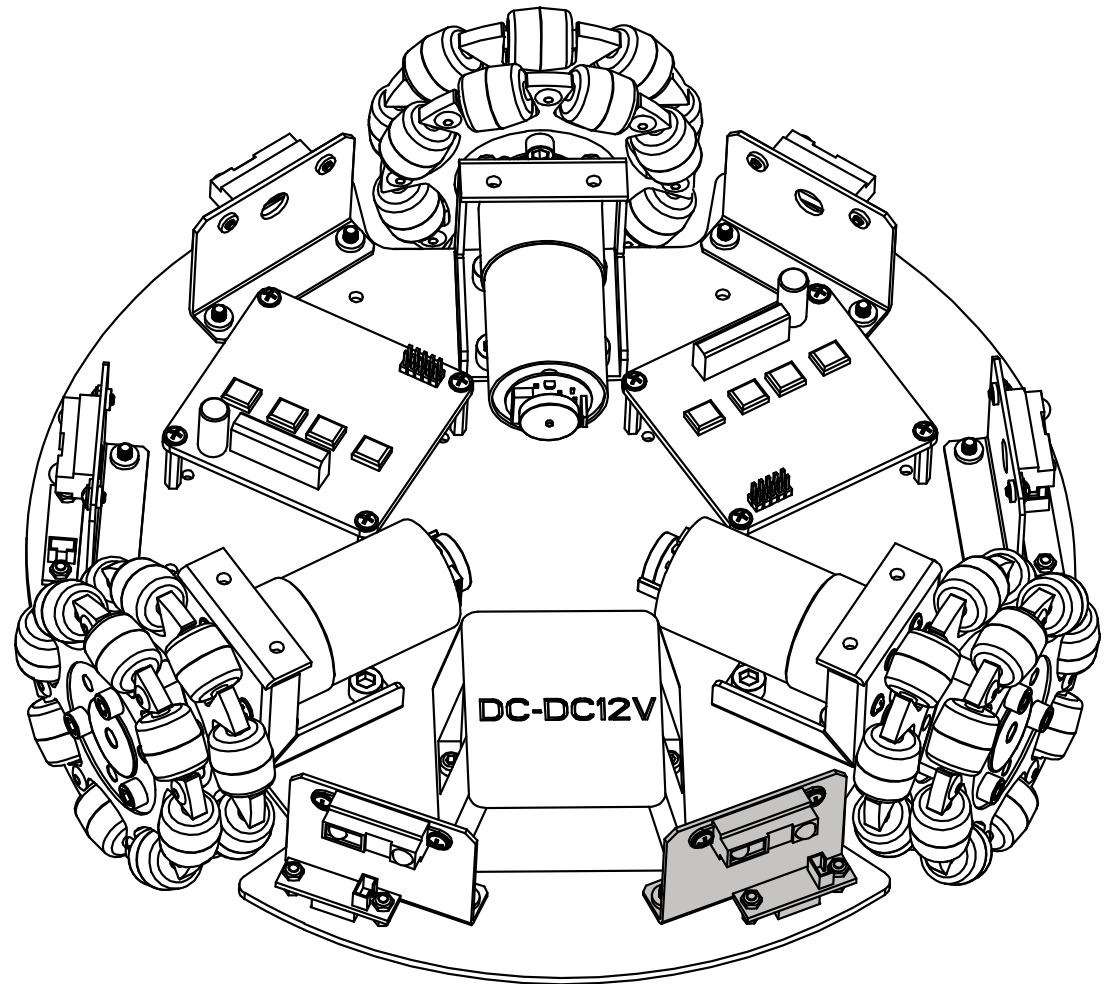
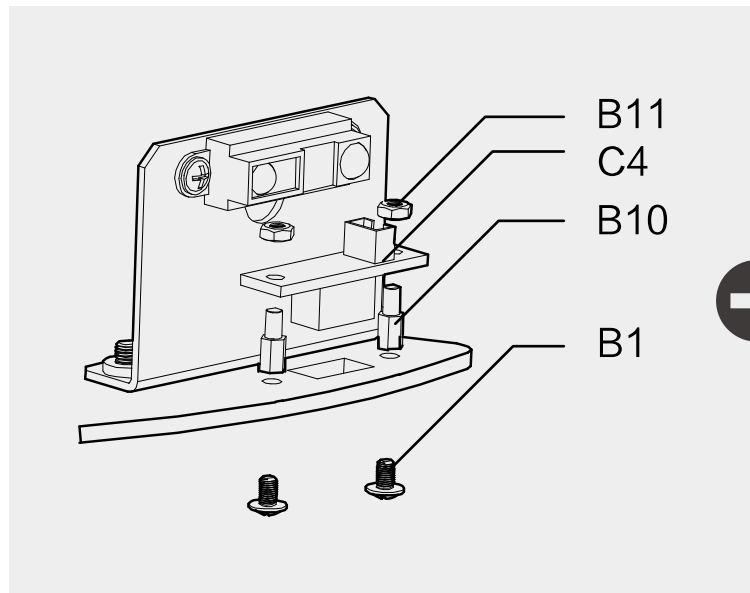

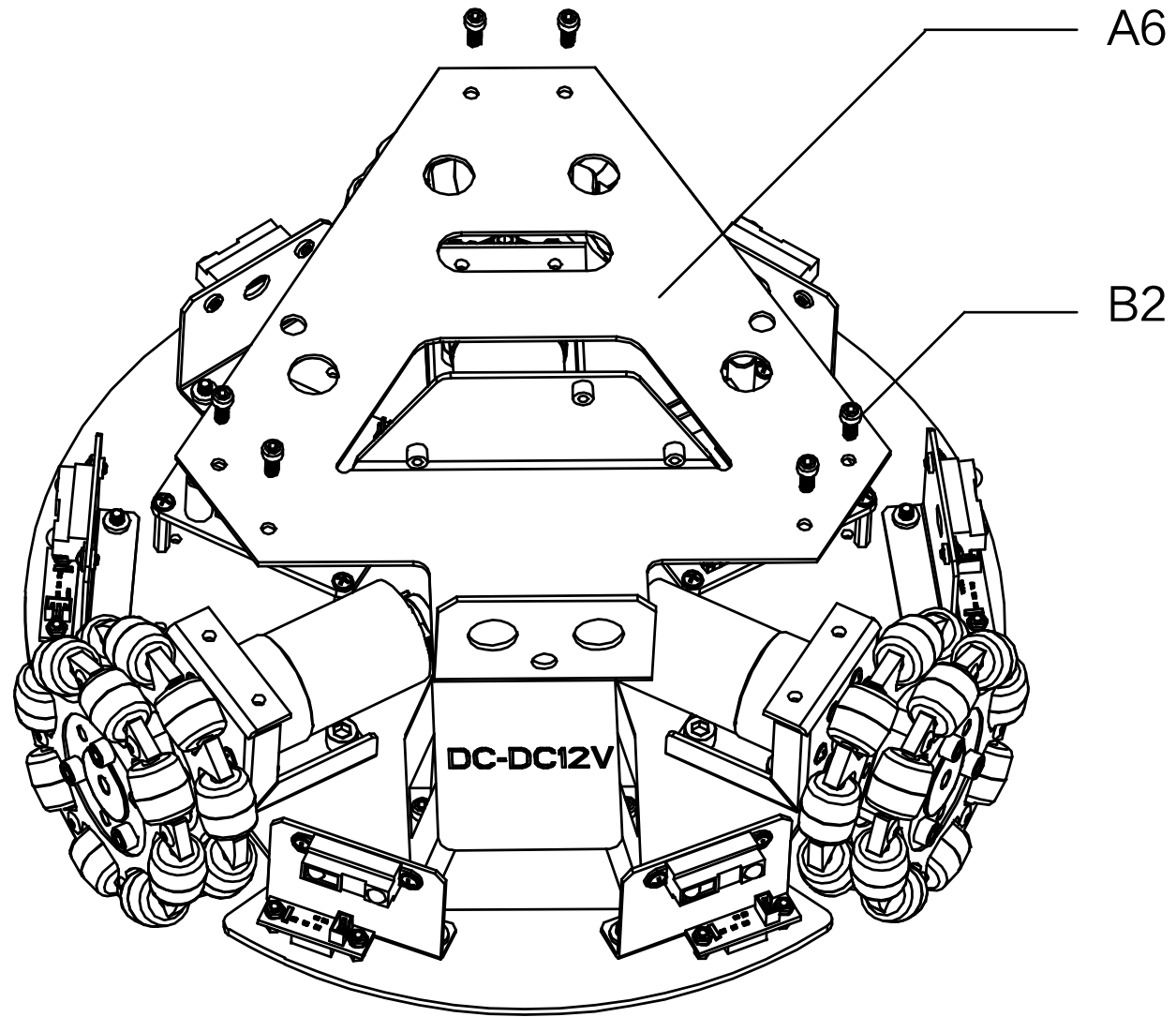

9

# Install Battery(Optional Parts)

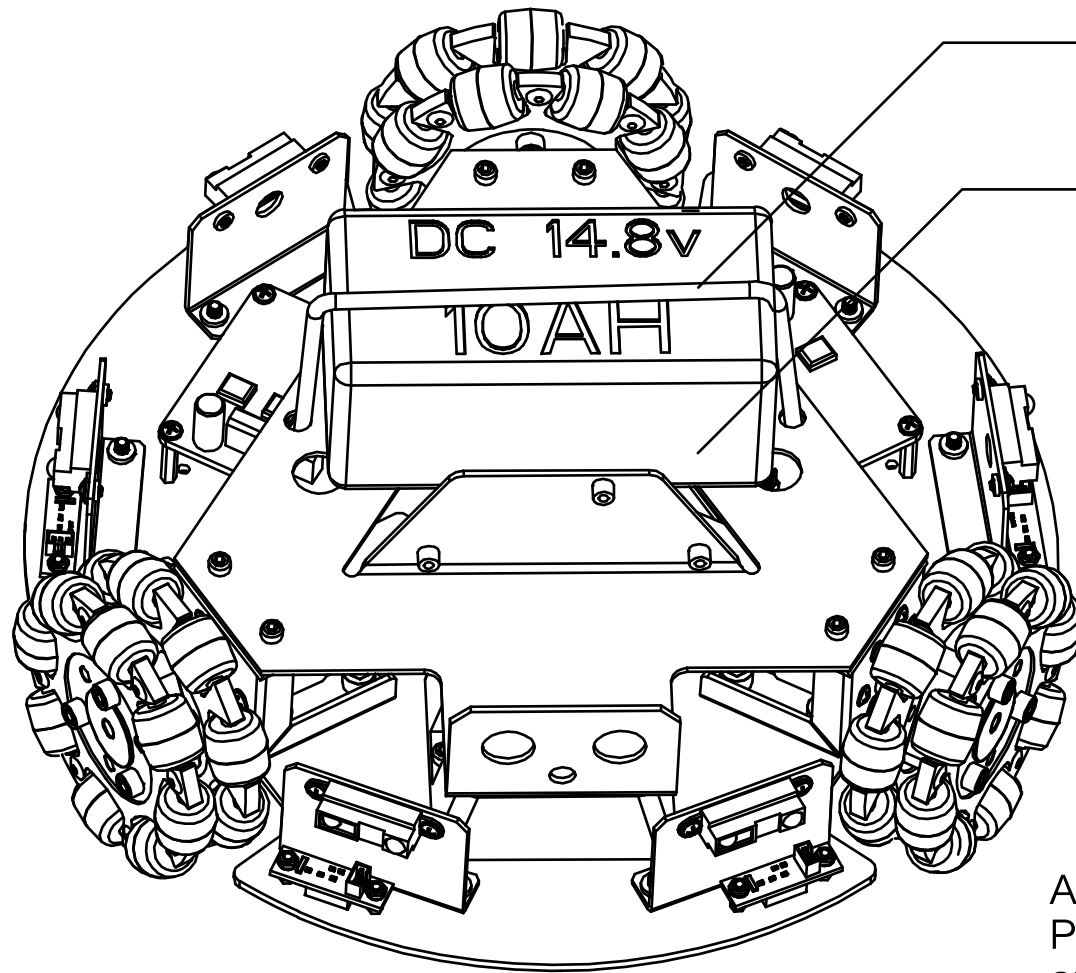

A8

B2、A7

A8 (Elastic Rope)  
Put Velcro stickers onto the back side of the battery holder  
and the upper side of the base plate)

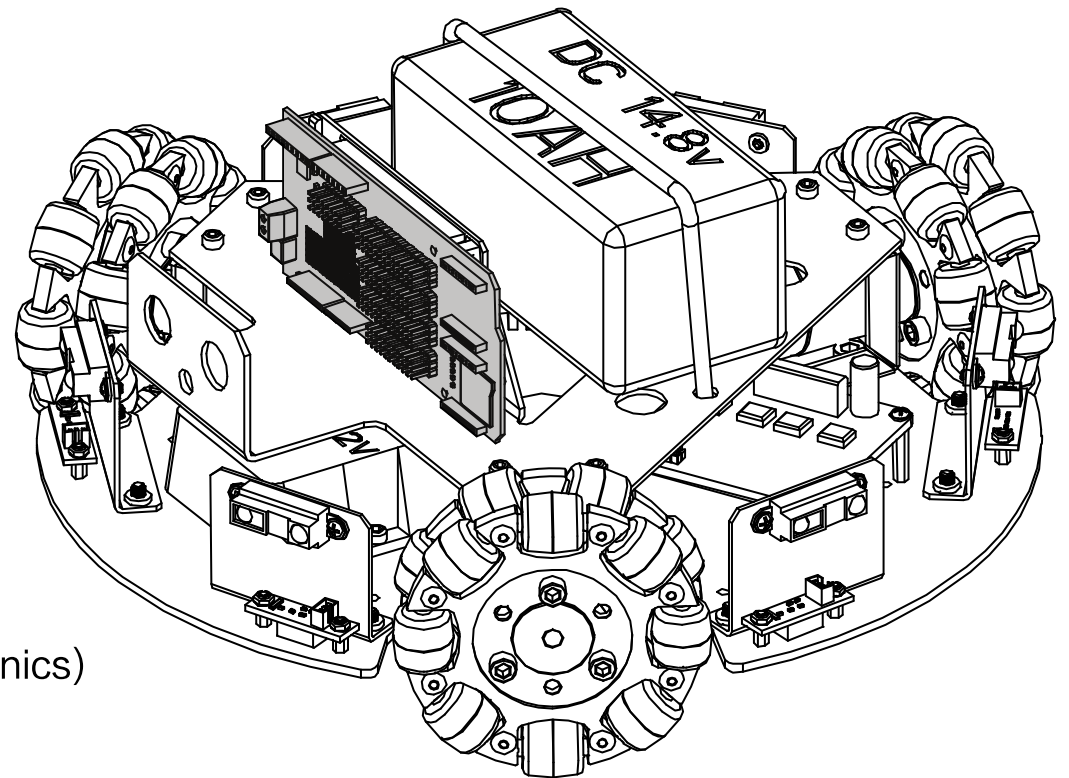
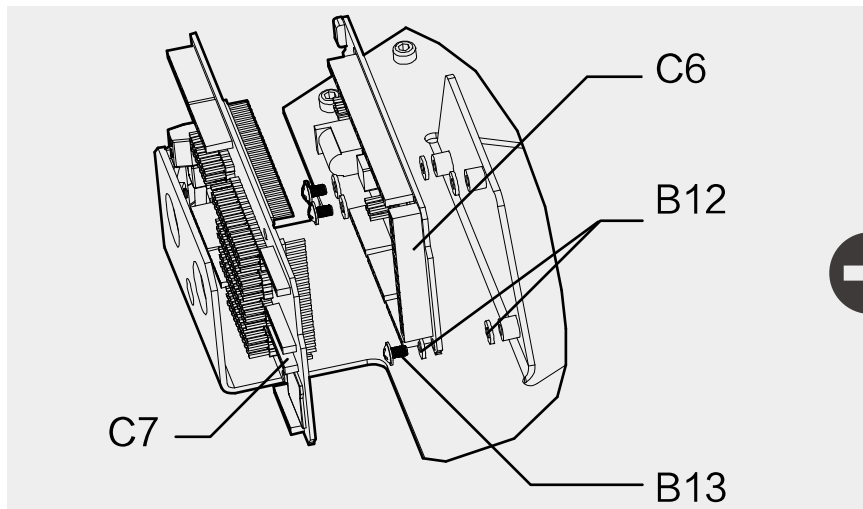

B12(Use nylon spacers to prevent damage to electronics)

# 11 Install Switches and Sockets

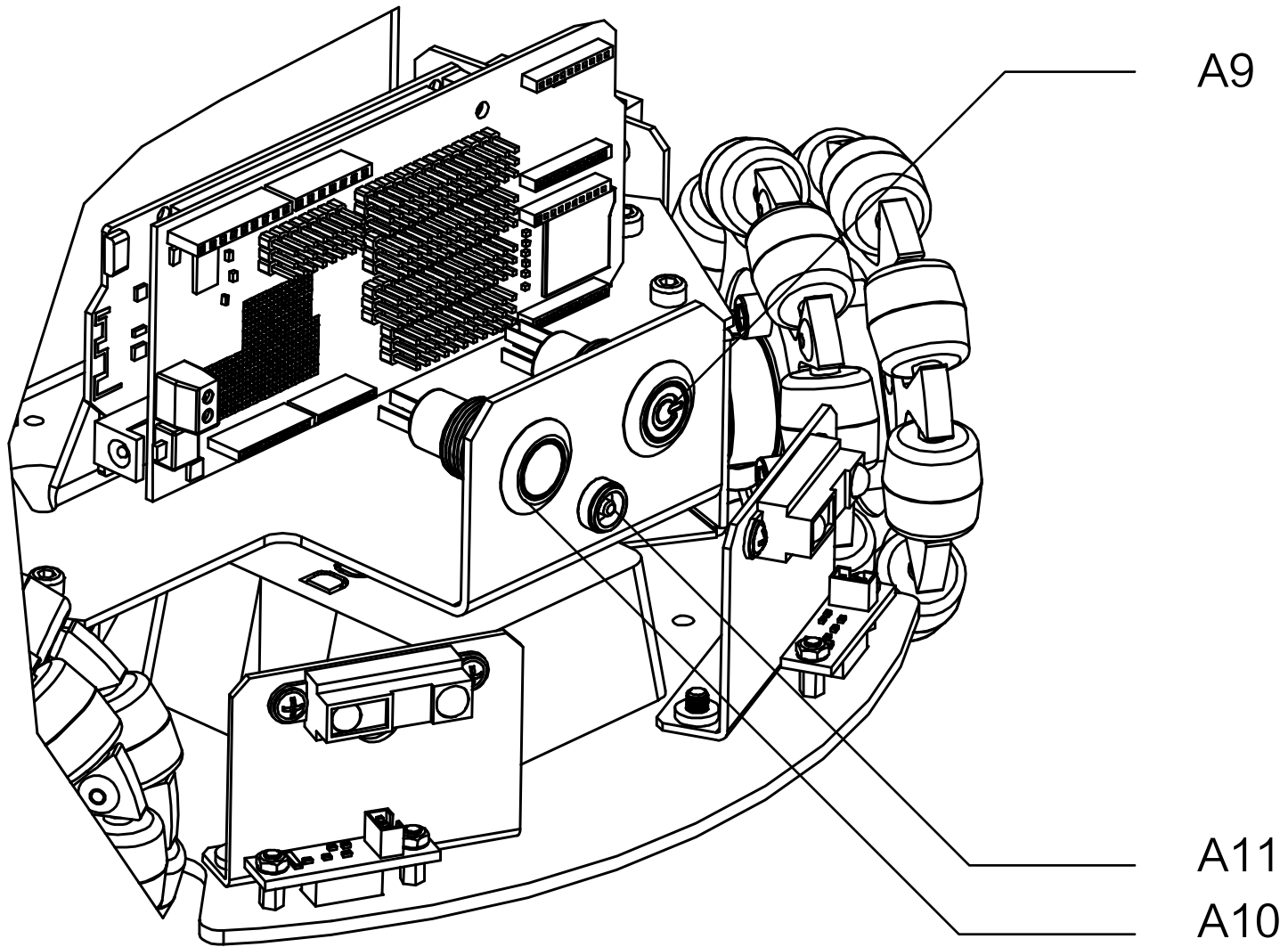



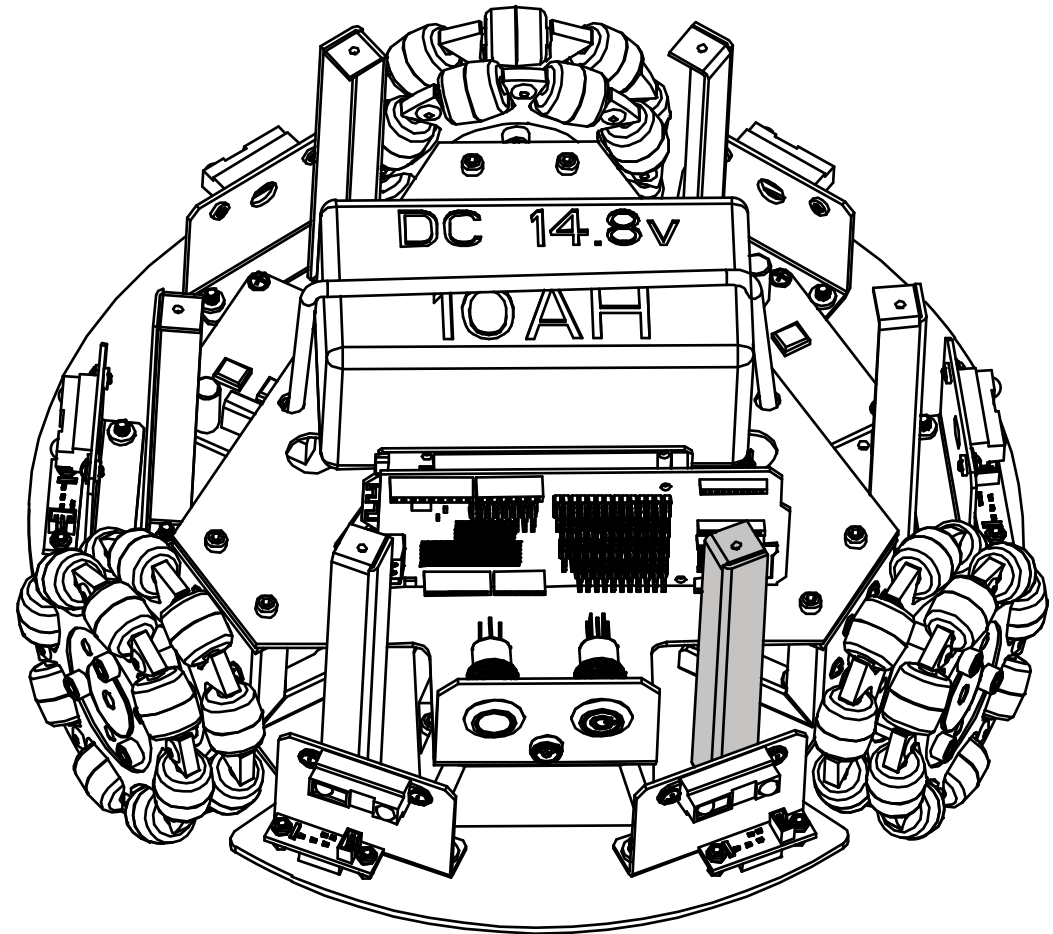
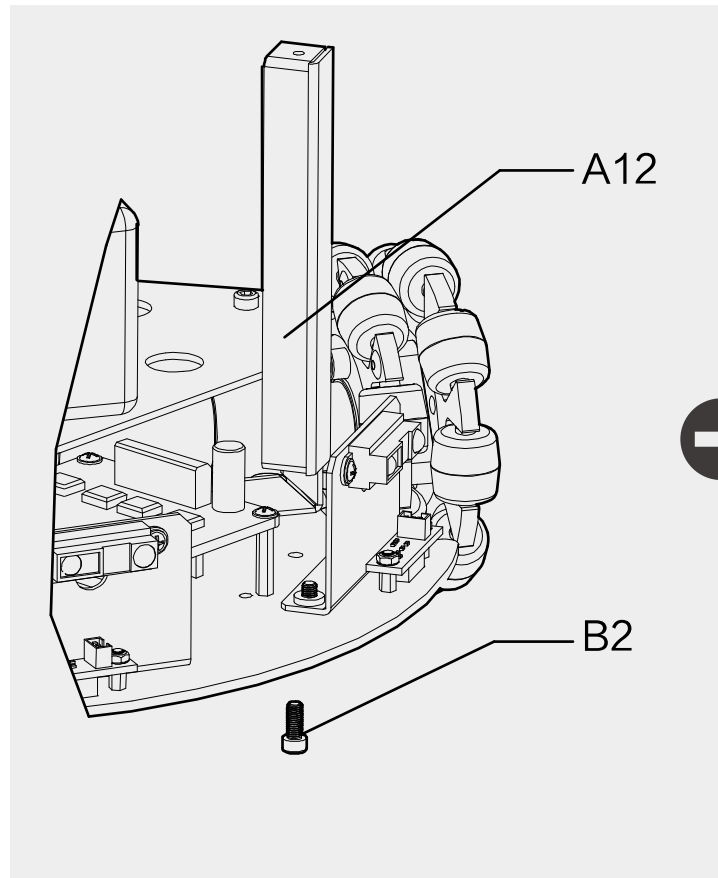

Before installing any further structural parts, you need to install a few electric components in advance.

# 13 Install Plate

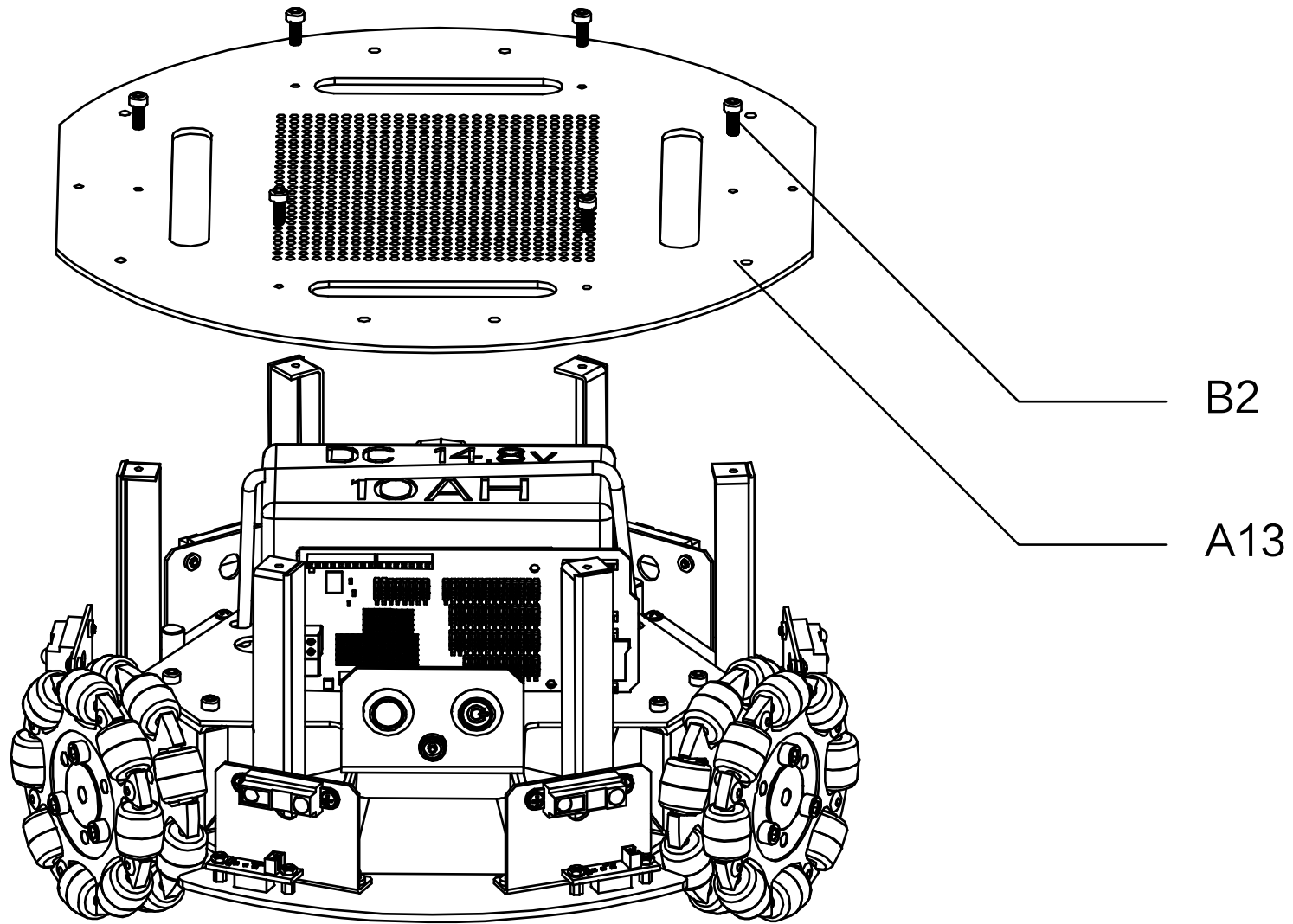

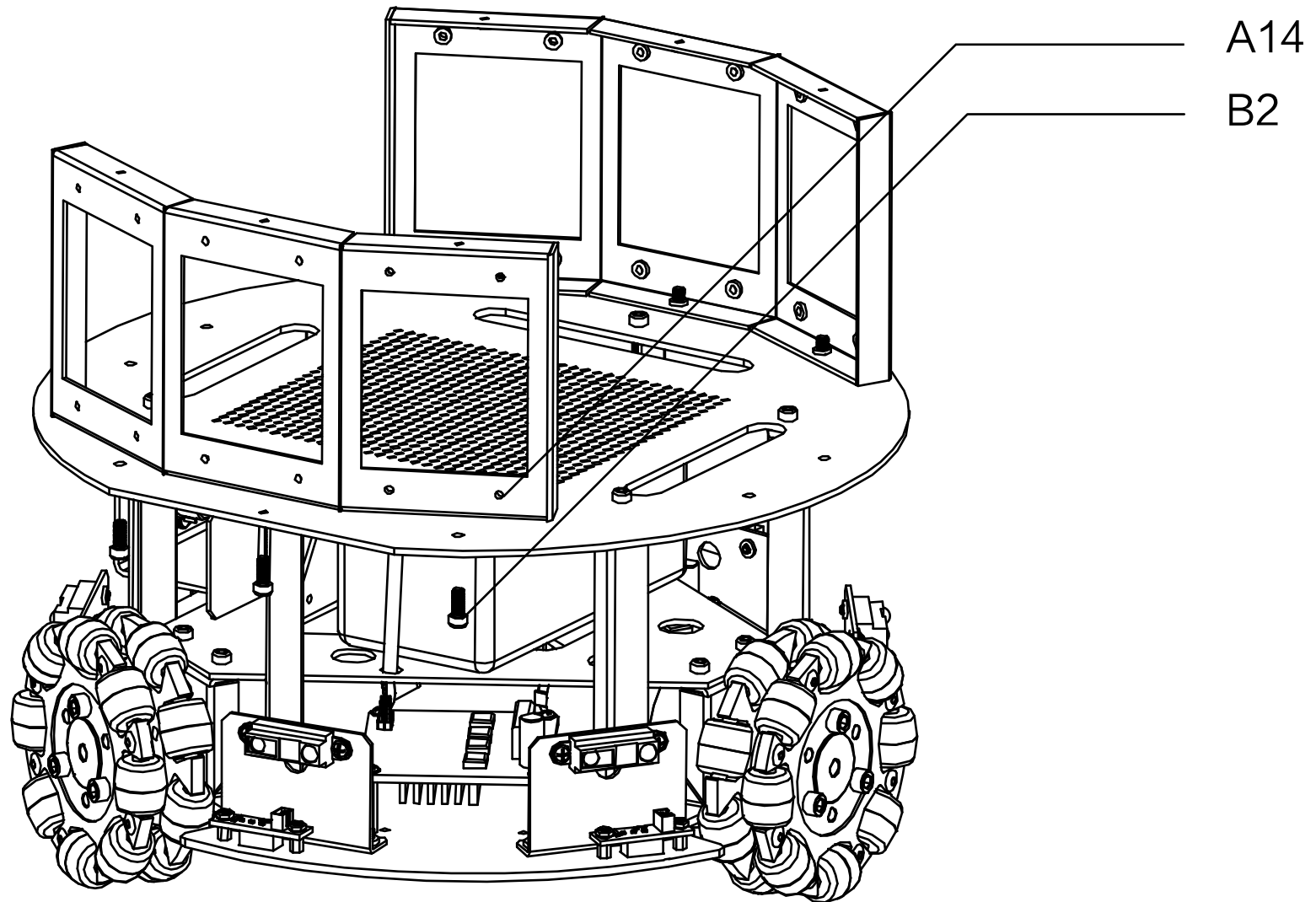

# 15 Install Conversion Board(Optional Parts)

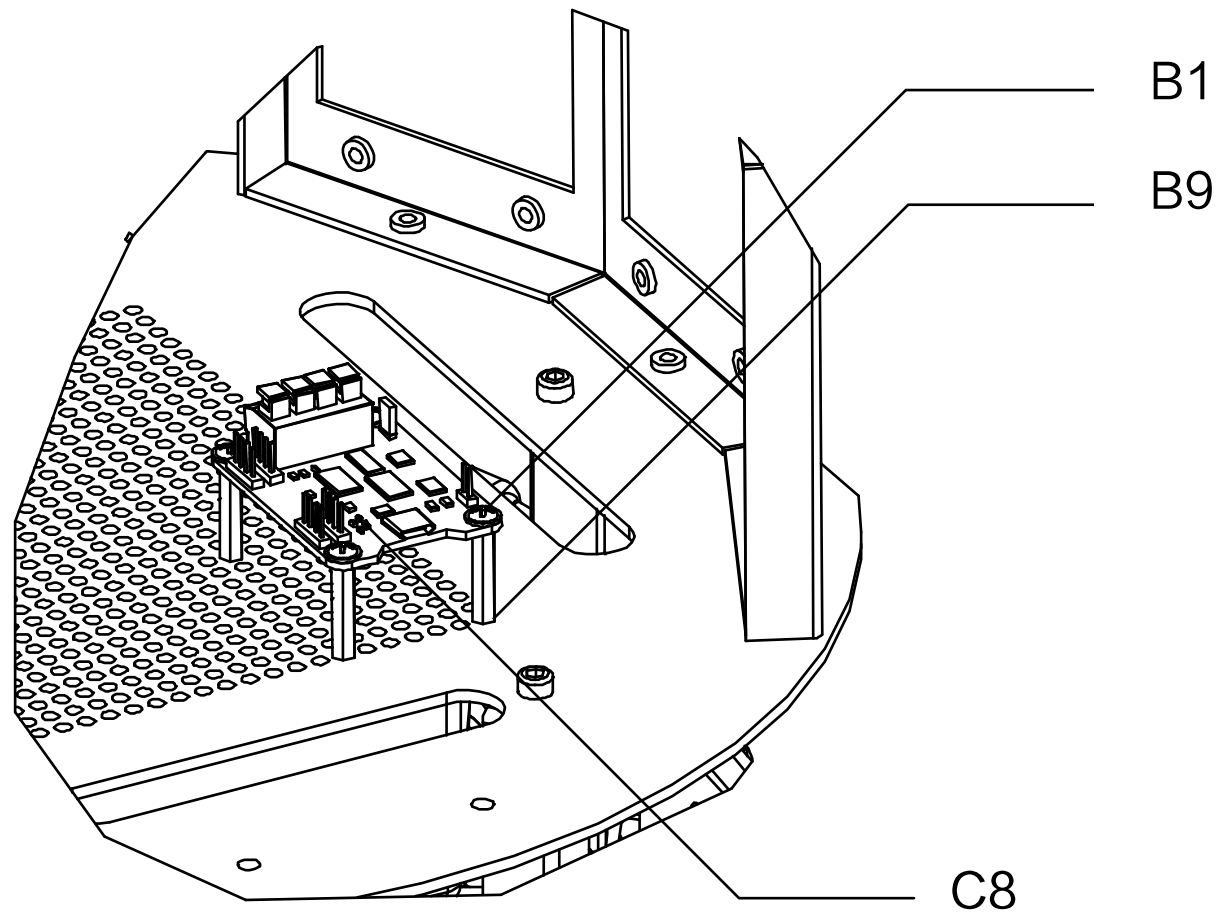

B1(Secure standoffs from top and bottom )

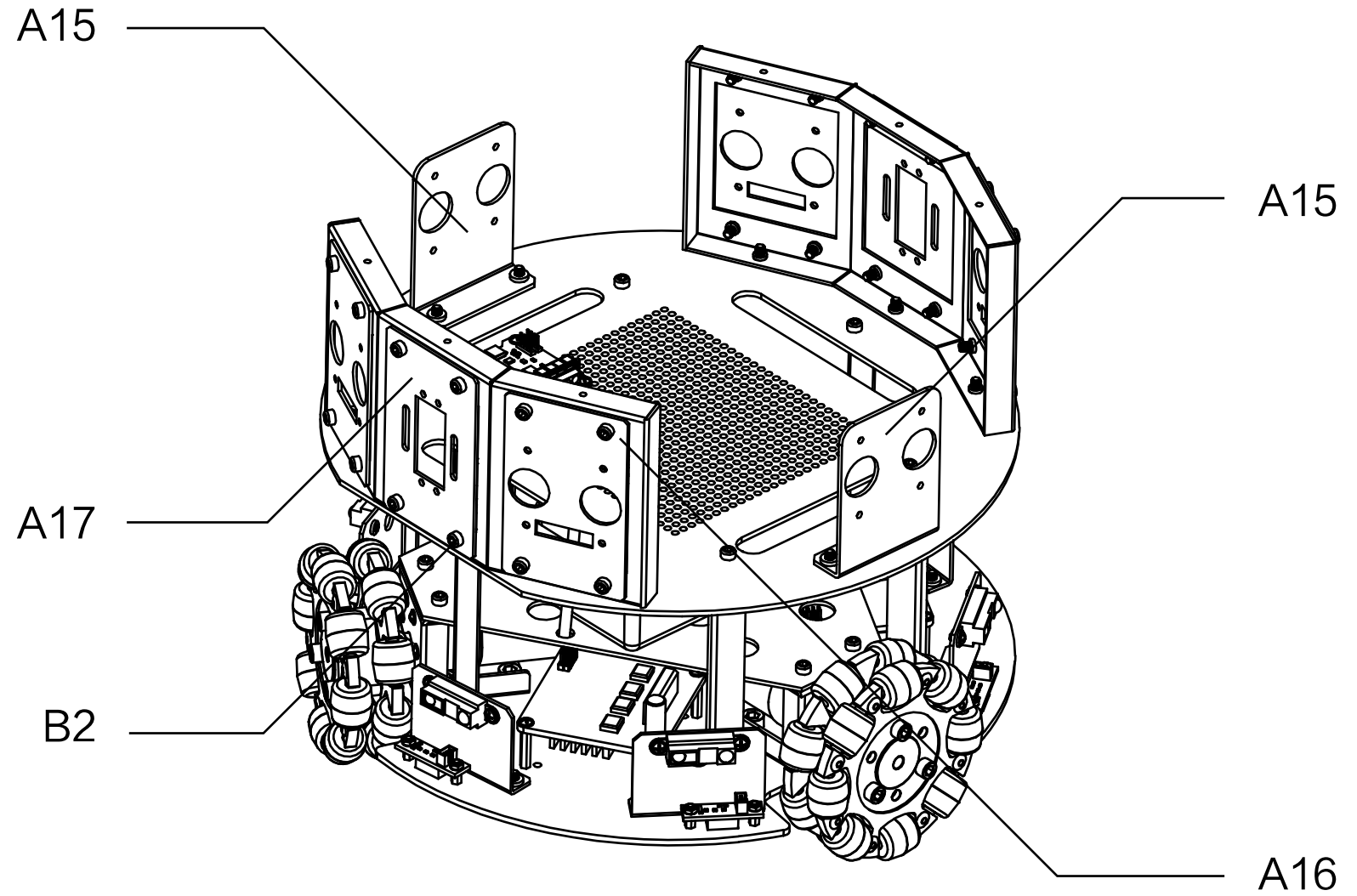

# 17 Install Ultrasonic Sensors(Optional Parts)

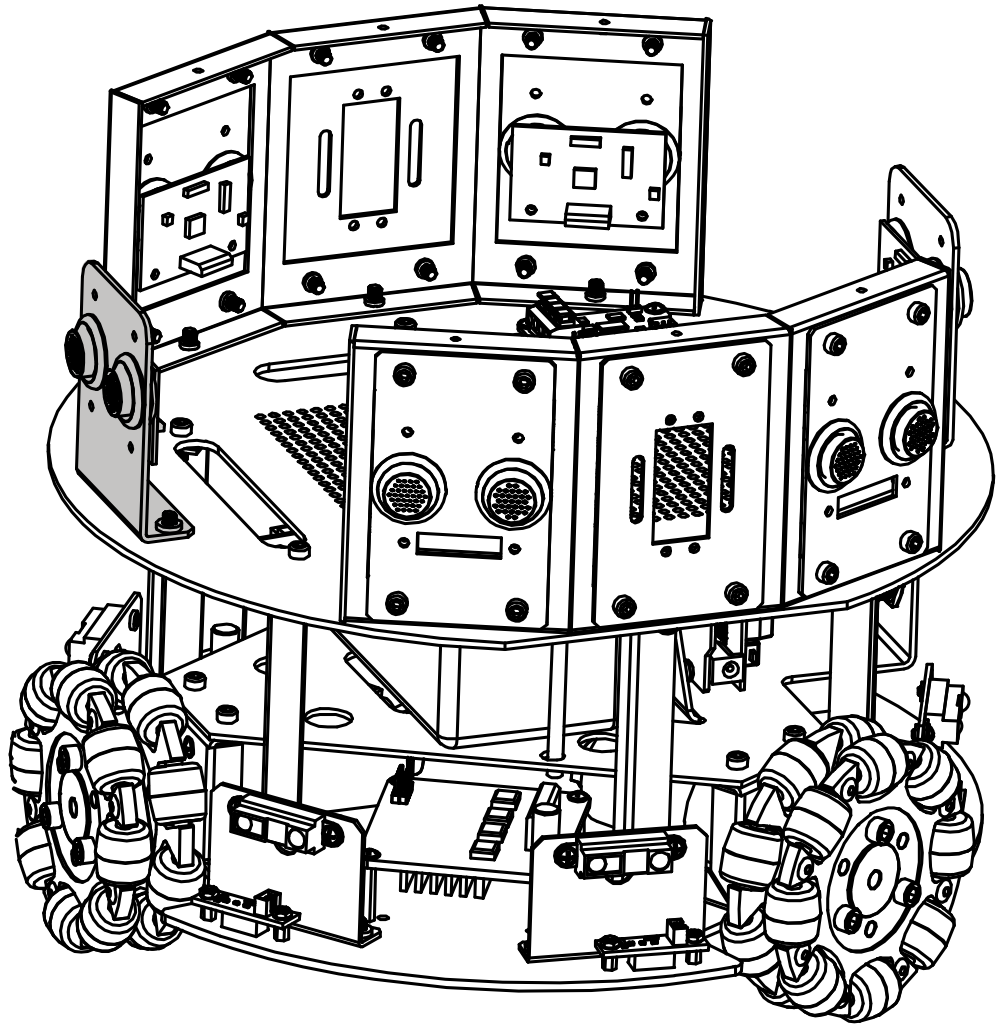
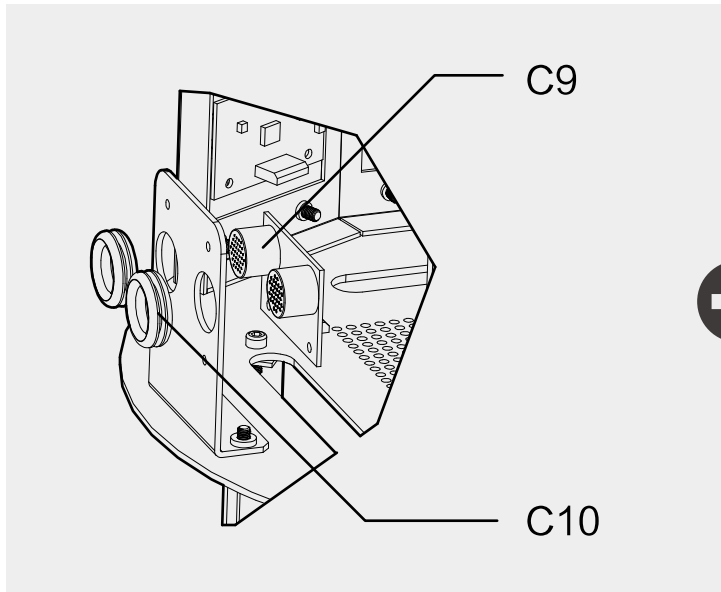

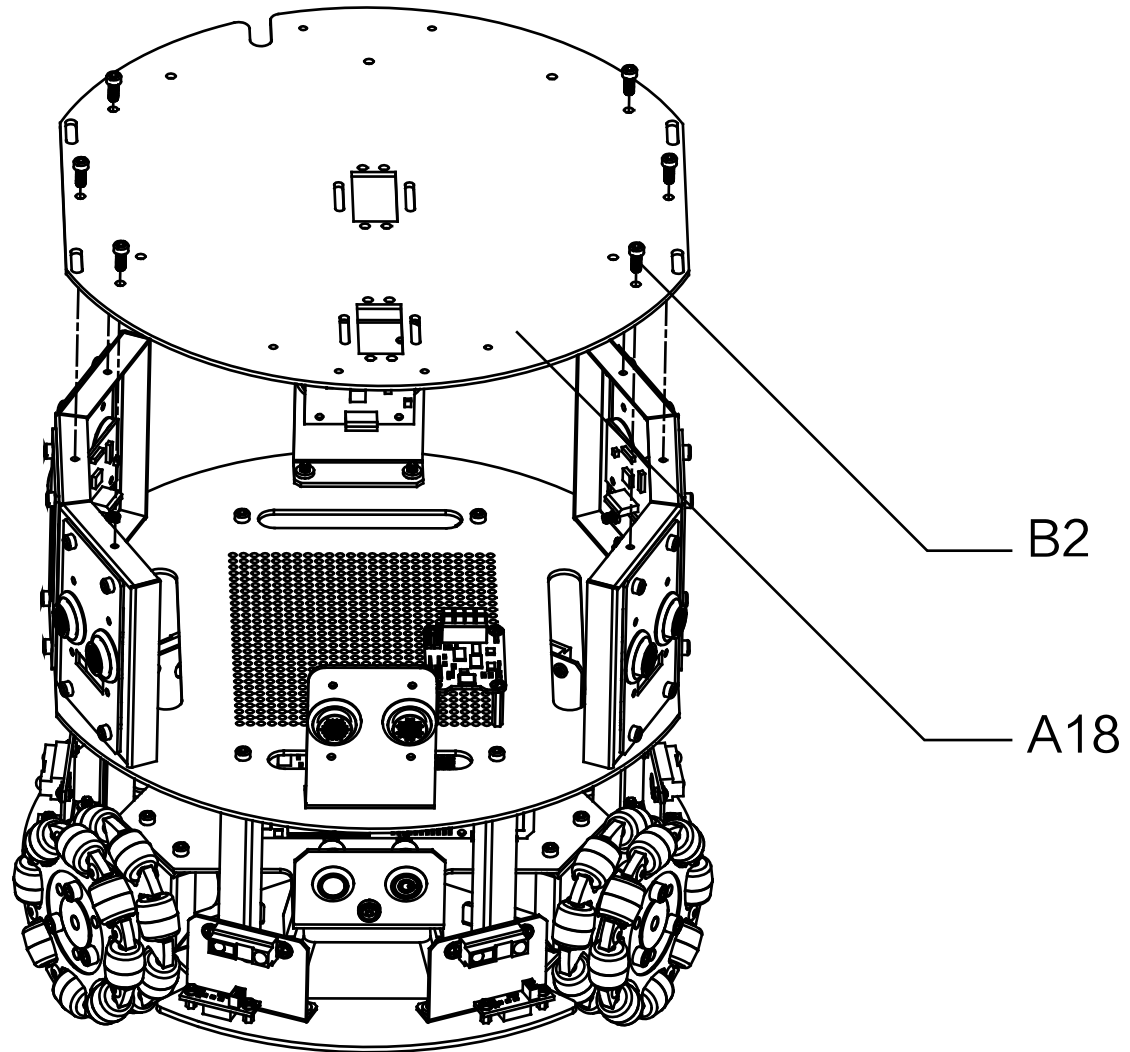

# 19 Attach Pillars and Plate

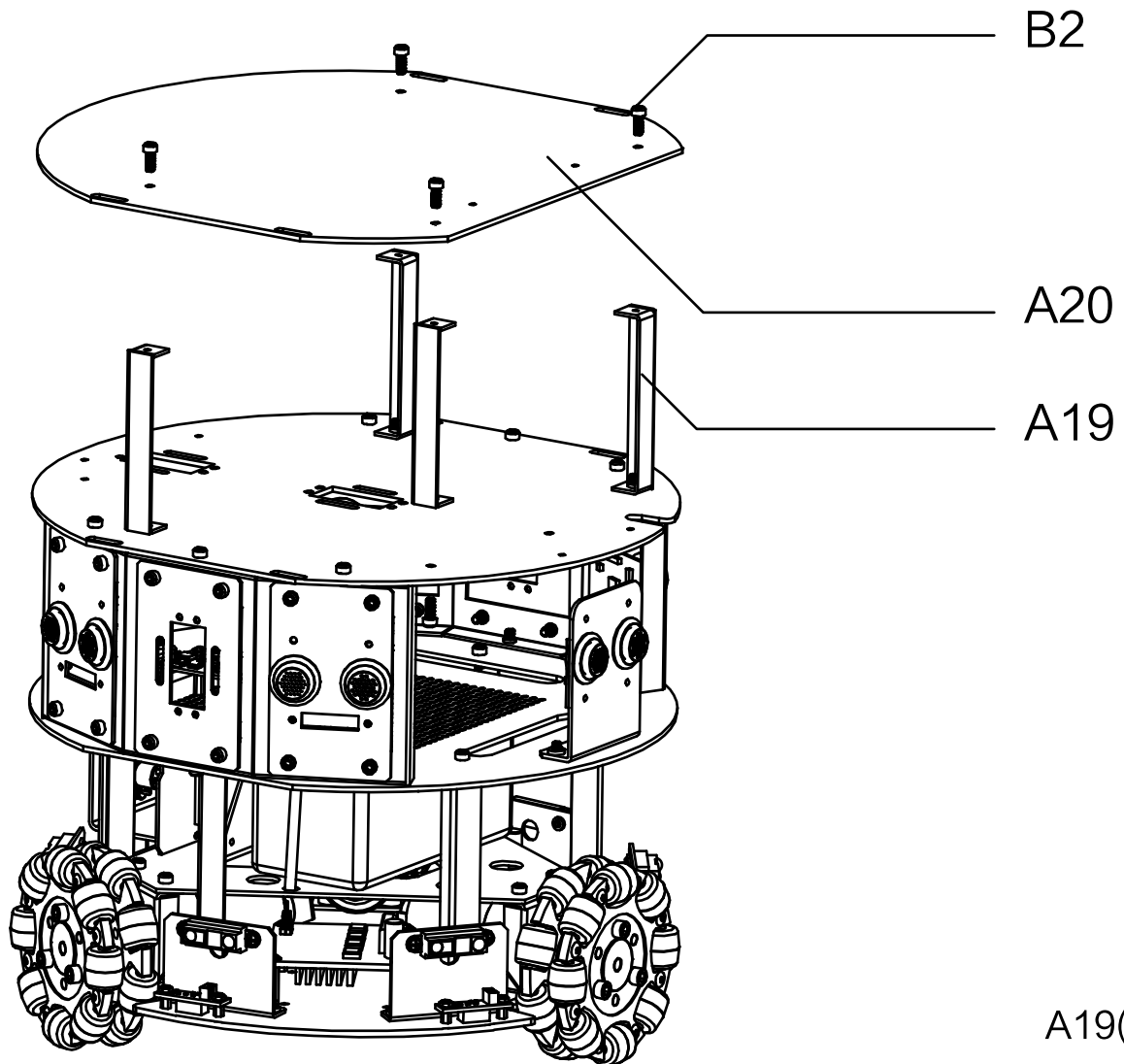

A19(Secure from top and bottom )



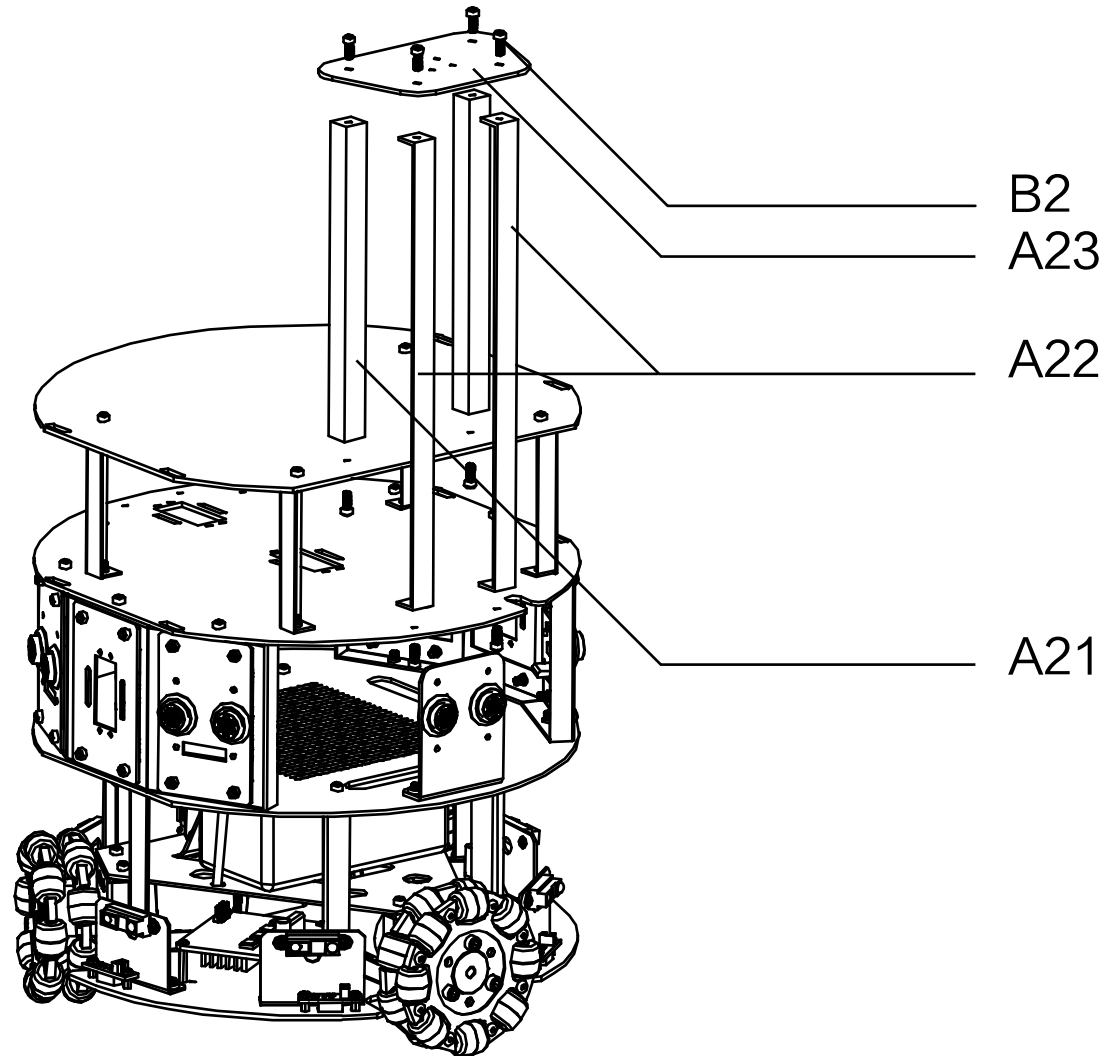

# 21 Install Kinect Bracket

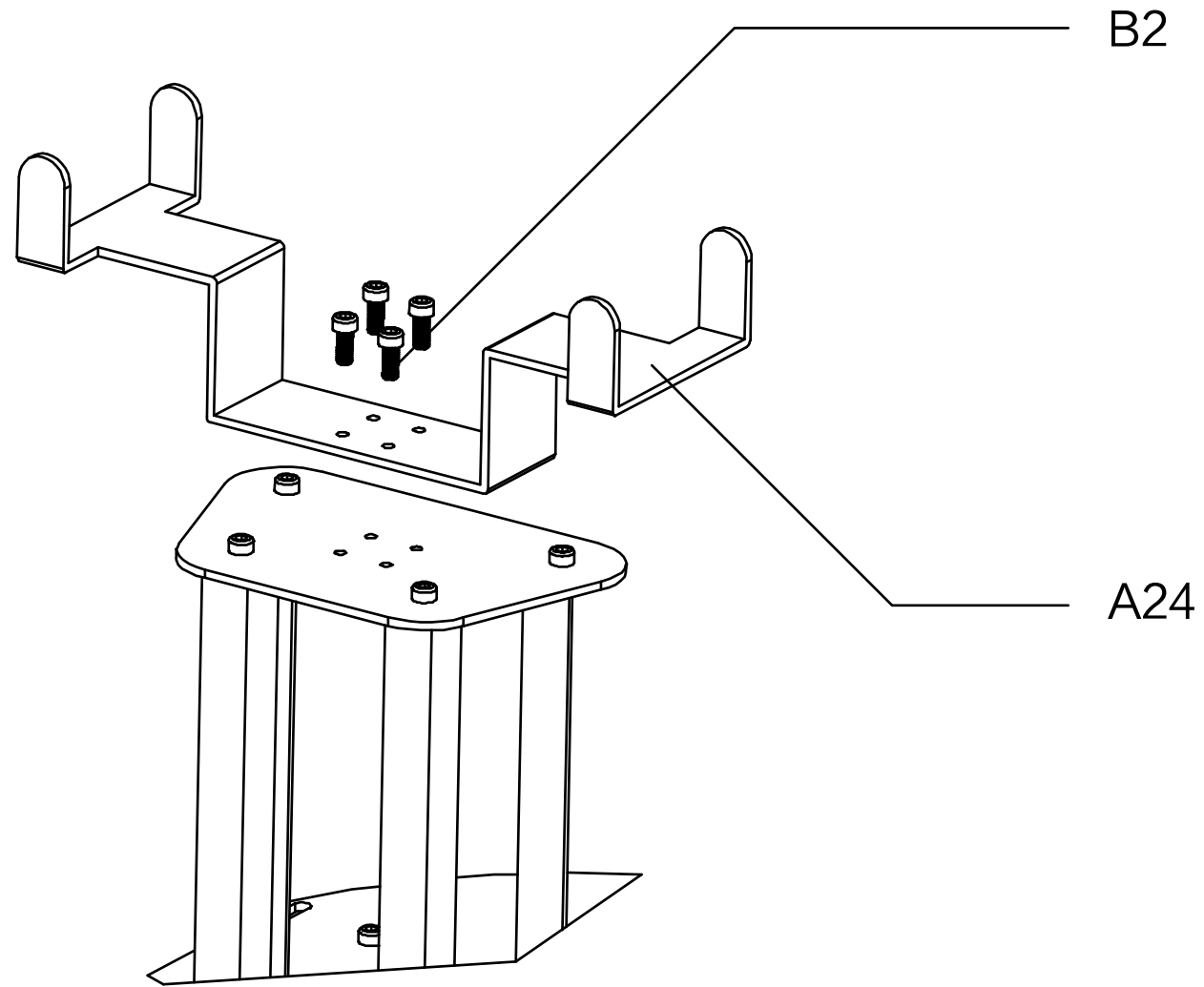

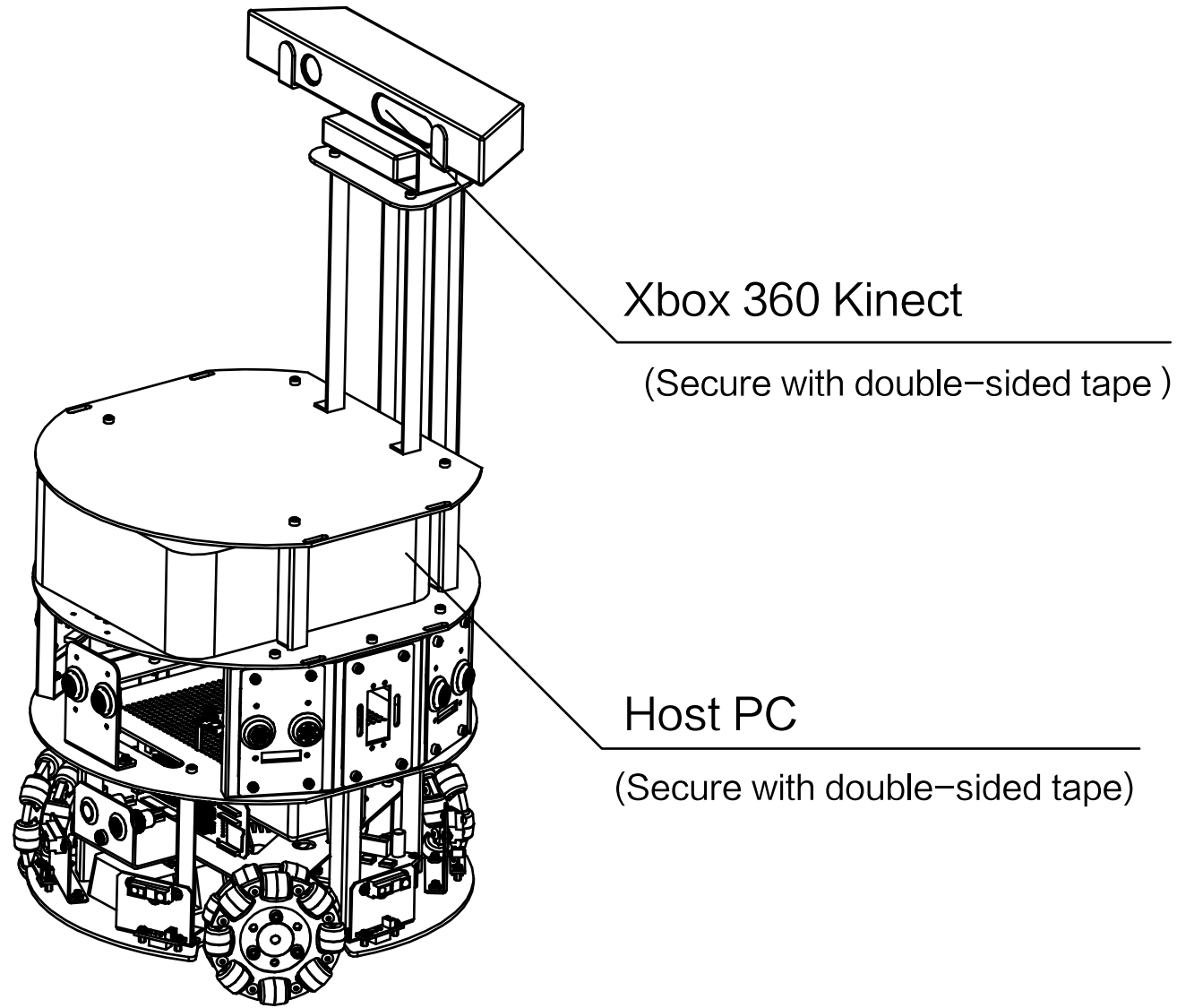

Website: [www.dfrobot.com](http://www.dfrobot.com)

Tel: 86-21-61620183

Service: [Techsupport@dfrobot.com](mailto:Techsupport@dfrobot.com)

Address: Rm. 615, Bldg Y1, NO.112, Liangxiu Rd., Pudong, China

© DFRobot has the final authority of interpretation on this manual.