

ST25TA NFC Forum Type 4 Tag IC evaluation board

Introduction

The CLOUD-ST25TA is an evaluation board based on the ST25TA02K-P device, allowing to assess the features and capabilities of the ST25TA circuit series.

The kit consists in a ready-to-use printed circuit board equipped with an ST25TA02K-P NFC/RFID Tag and a 19 mm single layer inductive antenna etched on the PCB.

The ST25TA is NFC/RFID Tag IC with a General Purpose Output (GPO) that features a 256 Bytes (2 Kbit) EEPROM with NDEF data support. Provision for a connector to operate the ST25TA GPO is also provided.

The EEPROM is powered and operated through its contactless interface, compliant with NFC Forum Type 4 Tag and ISO/IEC 14443 Type A.

An external power supply is needed to use the ST25TA GPO.

Figure 1. CLOUD-ST25TA board



Table 1. Ordering info

| Reference | Order code |
|----------------|------------------|
| CLOUD – ST25TA | CLOUDST25TA02K-P |

Contents

- 1 Features 5**
- 2 Description 6**
- 3 Hardware and layout description 7**
- 4 CLOUD-ST25TA powering and startup 9**
 - 4.1 Startup 9
 - 4.2 Using the GPO 9
- 5 Federal Communications Commission (FCC) and
Industry Canada (IC) compliance statements 11**
 - 5.1 FCC Compliance Statement11
 - 5.1.1 Part 15.19 11
 - 5.1.2 Part 15.105 11
 - 5.1.3 Part 15.21 11
 - 5.2 IC Compliance Statement11
 - 5.2.1 Compliance Statement 11
 - 5.2.2 Déclaration de conformité 11
- 6 Revision history 13**

List of tables

| | | |
|----------|-------------------------------------|----|
| Table 1. | Ordering info | 1 |
| Table 2. | Bill of material | 8 |
| Table 3. | Document revision history | 13 |

List of figures

| | | |
|-----------|--|---|
| Figure 1. | CLOUD-ST25TA board..... | 1 |
| Figure 2. | CLOUD-ST25TA functional block diagram..... | 6 |
| Figure 3. | CLOUD-ST25TA board description | 7 |
| Figure 4. | CLOUD-ST25TA schematics | 8 |
| Figure 5. | Using the GPO | 9 |

1 Features

- Ready-to-use printed circuit board including:
 - ST25TA02K-P NFC/RFID Tag in UDFPN5 ECOPACK2[®] package
 - 19 mm single layer inductive antenna etched on the PCB
- Contactless interface:
 - NFC Forum Type 4 Tag
 - ISO/IEC 14443 Type A
 - 106 kbps data rate
 - Internal 50 pF tuning capacitance allowing small inductive antenna design
- Memory:
 - 256 Bytes (2 Kbit) EEPROM with NDEF data support
 - 200 years data retention
 - 1 million erase-write cycles endurance
 - 128 bit password data protection
 - 20 bit events counter for read or write access with anti-tearing feature
- Digital pad
 - GPO: configurable General Purpose Output, indicating e.g. RF Field Detection
- Associated Android application for smartphone used as a NFC Reader, available on dedicated web pages on google.com and www.st.com.

2 Description

The CLOUD- ST25TA is a ready-to-use demo board intended to evaluate the ST25TA02K-P.

The ST25TA02K-P device is a dynamic NFC/RFID tag IC with a digital GPO embedding a 2 Kbit EEPROM that supports NDEF Tag Application for NFC Forum Type 4.

The device communicates using the ISO/IEC 14443 Type A protocol, and it's fully powered by the RF field. When the GPO output is used, an external reference voltage is required to set the high level voltage of the GPO signal: this allows to be directly compatible with the I/O voltage of the MCU or Host, without the need for any level shifter.

The GPO signal of the ST25TA02K-P is active (HIGH) when asserted and thus can be used as a rising edge interrupt. It may be configured through the RF interface for various functions, such as indicating Field Detection (by default) amongst others to wake-up an MCU or Host like Bluetooth or Wi-Fi chipset.

Figure 2. CLOUD-ST25TA functional block diagram

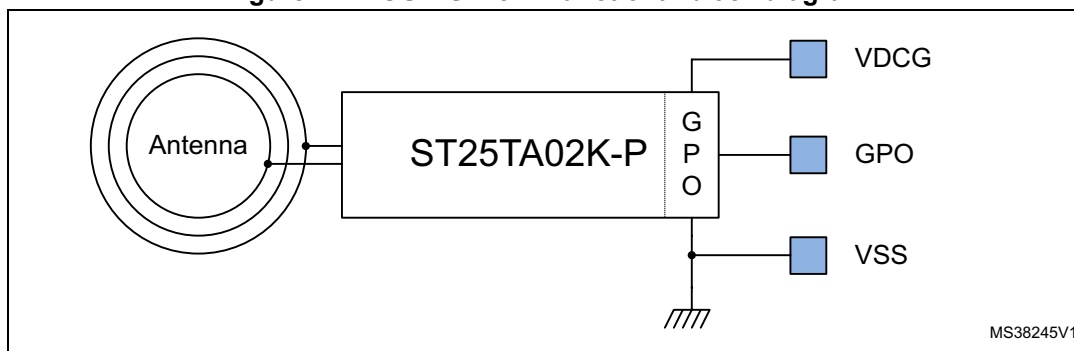

3 Hardware and layout description

The CLOUD-ST25TA board contains the ST25TA02K-P. It features a 2 Kbit EEPROM memory with NDEF data support. The memory is only powered and accessed from the RF interface, based on the ISO/IEC 14443 Type A standard.

The ST25TA02K-P is compatible with the NFC Forum Type 4 Tag specifications and supports all corresponding commands.

Additionally, the ST25TA02K-P features a GPO which is configurable through the RF interface and which indicates Tag activity. The GPO pad requests an external supply to operate.

The antenna has a 19 mm diameter, and it's etched only on one side of the PCB, as shown in [Figure 3](#).

Figure 3. CLOUD-ST25TA board description

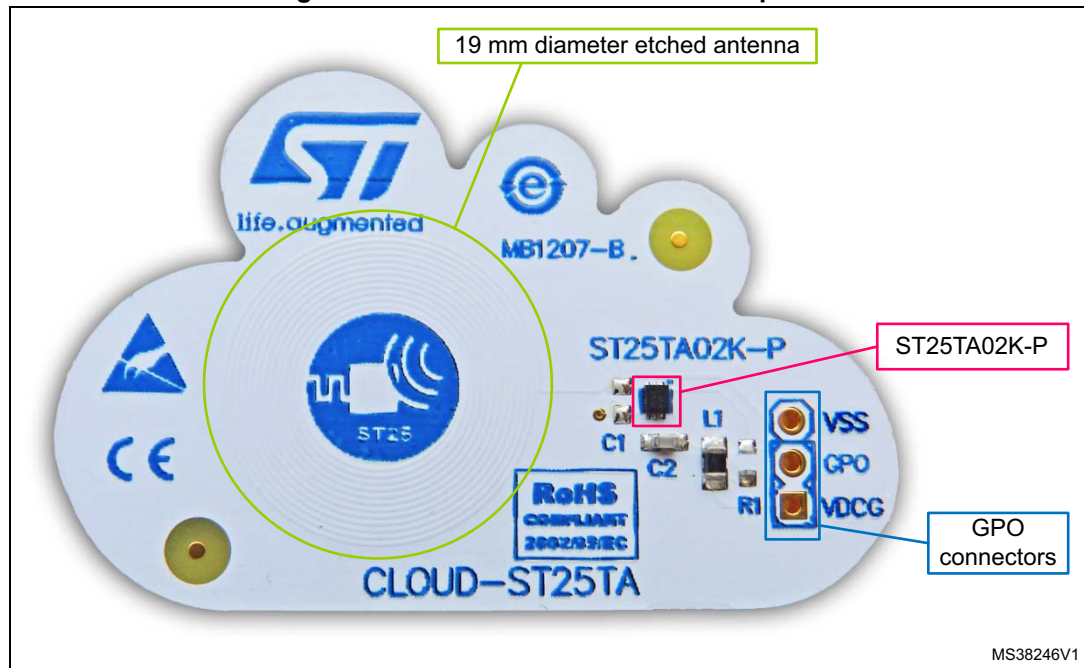

The electrical schematic diagram is shown in [Figure 4](#), while [Table 2](#) provides the list of used parts.

Figure 4. CLOUD-ST25TA schematics

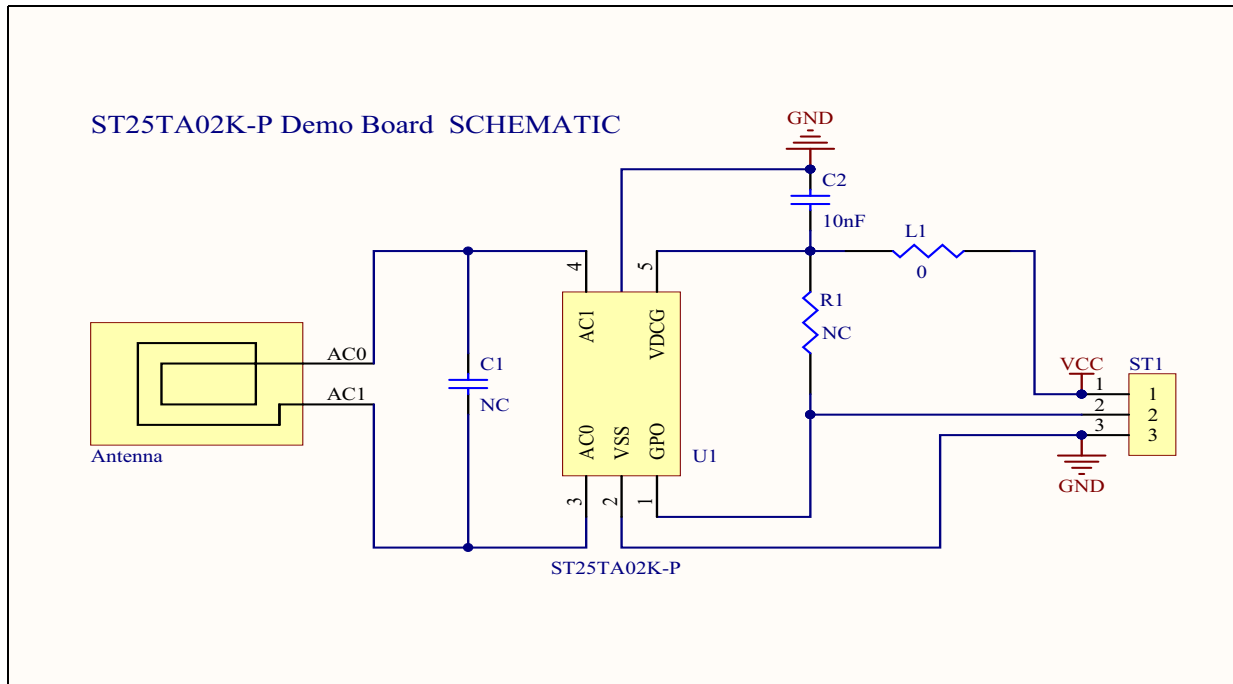

Table 2. Bill of material

| Quantity | Description | Reference | Package | Manufacturer | Part | Fitted |
|----------|--|-----------|----------------|--------------------|----------------|--------|
| 1 | Capacitor MLCC 0603 NP0 50V 2% NC | C1 | 0603 | - | - | No |
| 1 | Capacitor MLCC 0603 X7R 16V 10% 10nF | C2 | 0603 | - | - | - |
| 1 | Resistor CMS 0805 0 ohm | L1 | 0805 | - | - | - |
| 1 | Resistor CMS 0603 0,1W 5% NC | R1 | 0605 | - | - | No |
| 1 | ST25TA02K-P | U1 | UFDFPN5 | STMicroelectronics | - | - |
| 1 | Connector 3PTS 2,54, NC | ST1 | CON_3PTS_P2.54 | FCI | 77311-401-36LF | No |

4 CLOUD-ST25TA powering and startup

The CLOUD-ST25TA is powered by the RF field which means that users do not need external power supply for either reading or writing the memory. However, an external power is needed to use the GPO.

4.1 Startup

The CLOUD-ST25TA is already programmed with an URI which will automatically redirect to the associated ST web page. User needs to:

- enable NFC on the phone (Settings → Wireless and Networks → NFC) and make sure it is also connected to the Internet;
- bring the phone close to the CLOUD-ST25 antenna to be redirected to ST25TA web page.

Various uses of the CLOUD-ST25TA with a smartphone are allowed with application for Android.

To download the application and for more use cases and details user should visit the dedicated pages on google.com and www.st.com.

4.2 Using the GPO

By default the GPO is not powered on the CLOUD-ST25TA board, however the GPO output voltage can easily accommodate supply voltage of associated Host. To use the GPO, users must provide the relevant supply (voltage ranging from 1.65 to 5.5 V) between VSS and VDCG pins, then probe the GPO behavior with an oscilloscope connected to the GPO pin (see [Figure 5](#)).

Figure 5. Using the GPO

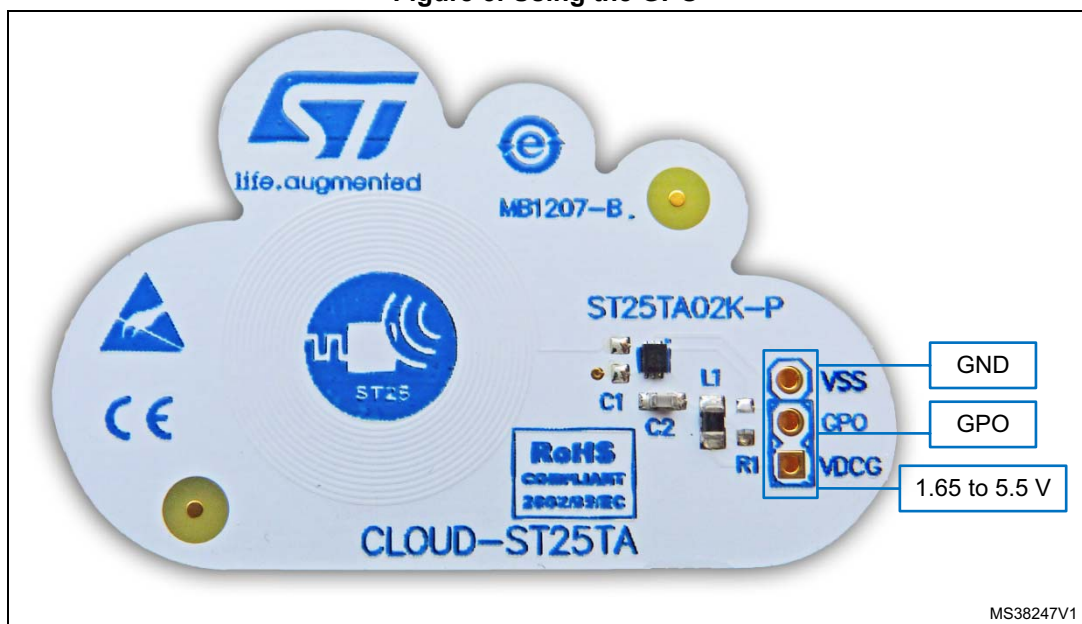

The GPO pin is active positive and by default configured as Field Detection which means that GPO voltage varies from LOW to HIGH when a field is sufficient to power the ST25TA02K-P.

User should enable the NFC on the phone, and bring it close to the CLOUD-ST25 antenna (2 centimeters or less), GPO goes HIGH. Taking the phone away from the Tag, GPO goes back to LOW.

5 Federal Communications Commission (FCC) and Industry Canada (IC) compliance statements

5.1 FCC Compliance Statement

5.1.1 Part 15.19

This device complies with Part 15 of the FCC Rules. Operation is subject to the following two conditions: (1) this device may not cause harmful interference, and (2) this device must accept any interference received, including interference that may cause undesired operation.

5.1.2 Part 15.105

This equipment has been tested and found to comply with the limits for a Class B digital device, pursuant to part 15 of the FCC Rules. These limits are designed to provide reasonable protection against harmful interference in a residential installation. This equipment generates uses and can radiate radio frequency energy and, if not installed and used in accordance with the instructions, may cause harmful interference to radio communications. However, there is no guarantee that interference will not occur in a particular installation. If this equipment does cause harmful interference to radio or television reception, which can be determined by turning the equipment off and on, the user is encouraged to try to correct the interference's by one or more of the following measures:

- Reorient or relocate the receiving antenna.
- Increase the separation between the equipment and the receiver.
- Connect the equipment into an outlet on a circuit different from that to which the receiver is connected.
- Consult the dealer or an experienced radio/TV technician for help.

5.1.3 Part 15.21

Any changes or modifications to this equipment not expressly approved by STMicroelectronics may cause harmful interference and void the user's authority to operate this equipment.

5.2 IC Compliance Statement

5.2.1 Compliance Statement

This device complies with Industry Canada licence-exempt RSS standard(s). Operation is subject to the following two conditions: (1) this device may not cause interference, and (2) this device must accept any interference, including interference that may cause undesired operation.

5.2.2 Déclaration de conformité

Le présent appareil est conforme aux CNR d'Industrie Canada applicables aux appareils radio exempts de licence. L'exploitation est autorisée aux deux conditions suivantes: (1)

Federal Communications Commission (FCC) and Industry Canada (IC) compliance statements

l'appareil ne doit pas produire de brouillage, et (2) l'utilisateur de l'appareil doit accepter tout brouillage radioélectrique subi, même si le brouillage est susceptible d'en compromettre le fonctionnement.

6 Revision history

Table 3. Document revision history

| Date | Revision | Changes |
|-------------|----------|------------------|
| 18-Jun-2015 | 1 | Initial release. |

IMPORTANT NOTICE – PLEASE READ CAREFULLY

STMicroelectronics NV and its subsidiaries ("ST") reserve the right to make changes, corrections, enhancements, modifications, and improvements to ST products and/or to this document at any time without notice. Purchasers should obtain the latest relevant information on ST products before placing orders. ST products are sold pursuant to ST's terms and conditions of sale in place at the time of order acknowledgement.

Purchasers are solely responsible for the choice, selection, and use of ST products and ST assumes no liability for application assistance or the design of Purchasers' products.

No license, express or implied, to any intellectual property right is granted by ST herein.

Resale of ST products with provisions different from the information set forth herein shall void any warranty granted by ST for such product.

ST and the ST logo are trademarks of ST. All other product or service names are the property of their respective owners.

Information in this document supersedes and replaces information previously supplied in any prior versions of this document.

© 2015 STMicroelectronics – All rights reserved