

DEO-Nano-Soc

USER MANUAL

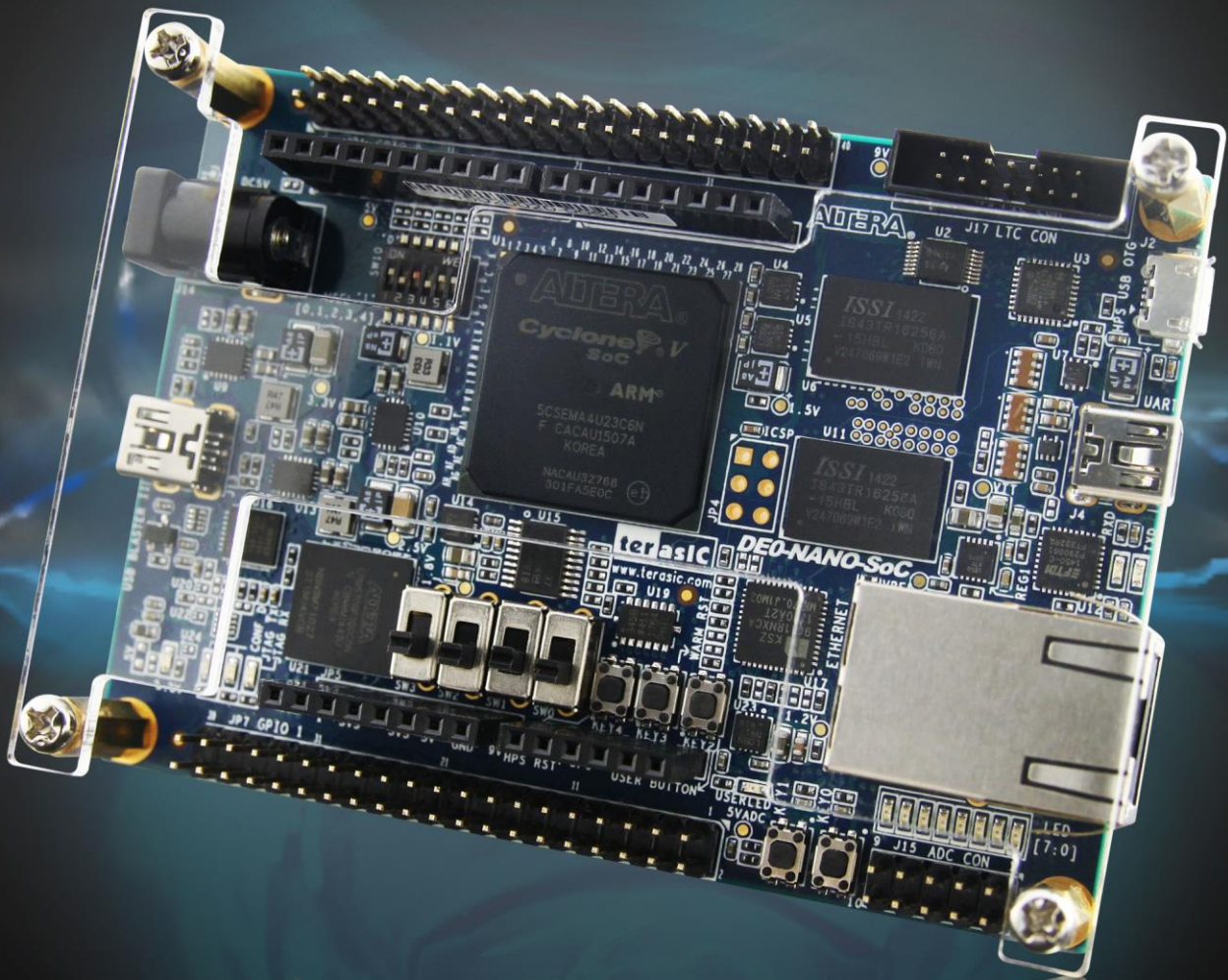

Chapter 1	DE0-Nano-SoC Development Kit	4
1.1	Package Contents	5
1.2	DE0-Nano-SoC System CD	5
1.3	Getting Help	6
Chapter 2	Introduction of the DE0-Nano-SoC Board	7
2.1	Layout and Components.....	7
2.2	Block Diagram of the DE0-Nano-SoC Board.....	9
Chapter 3	Using the DE0-Nano-SoC Board.....	12
3.1	Settings of FPGA Configuration Mode	12
3.2	Configuration of Cyclone V SoC FPGA on DE0-Nano-SoC.....	14
3.3	Board Status Elements	19
3.4	Board Reset Elements	20
3.5	Clock Circuitry	21
3.6	Peripherals Connected to the FPGA.....	22
3.6.1	User Push-buttons, Switches and LEDs	23
3.6.2	2x20 GPIO Expansion Headers.....	26
3.6.3	Arduino Uno R3 Expansion Header.....	29
3.6.4	A/D Converter and Analog Input	31
3.7	Peripherals Connected to Hard Processor System (HPS).....	33
3.7.1	User Push-buttons and LEDs	33
3.7.2	Gigabit Ethernet	33
3.7.3	UART	35
3.7.4	DDR3 Memory.....	36

3.7.5	Micro SD Card Socket	38
3.7.6	USB 2.0 OTG PHY	39
3.7.7	G-sensor	40
3.7.8	LTC Connector	40
Chapter 4	DE0-Nano-SoC System Builder	42
4.1	Introduction	42
4.2	Design Flow	42
4.3	Using DE0-Nano-SoC System Builder	43
Chapter 5	Examples For FPGA	49
5.1	DE0-Nano-SoC Factory Configuration.....	49
5.2	ADC Reading	50
Chapter 6	Examples for HPS SoC	53
6.1	Hello Program	53
6.2	Users LED and KEY	55
6.3	I2C Interfaced G-sensor	61
Chapter 7	Examples for using both HPS SoC and FGPA.....	65
7.1	HPS Control FPGA LED.....	65
Chapter 8	Programming the EPCS Device.....	69
8.1	Before Programming Begins	69
8.2	Convert .SOF File to .JIC File.....	70
8.3	Write JIC File into the EPCS Device	74
8.4	Erase the EPCS Device	75
8.5	EPCS Programming via nios-2-flash-programmer	76
8.6	Nios II Boot from EPCS Device in Quartus II v13.1 or later	77
Chapter 9	Appendix A	78

9.1 What's different between the DE0-Nano-SoC kit and the Atlas-SoC kit?..... 78

Chapter 10 Appendix B79

10.1 Revision History 79

10.2 Copyright Statement..... 79

Chapter 1

DE0-Nano-SoC Development Kit

The DE0-Nano-SoC Development Kit presents a robust hardware design platform built around the Altera System-on-Chip (SoC) FPGA, which combines the latest dual-core Cortex-A9 embedded cores with industry-leading programmable logic for ultimate design flexibility. Users can now leverage the power of tremendous re-configurability paired with a high-performance, low-power processor system. Altera's SoC integrates an ARM-based hard processor system (HPS) consisting of processor, peripherals and memory interfaces tied seamlessly with the FPGA fabric using a high-bandwidth interconnect backbone. The DE0-Nano-SoC development board is equipped with high-speed DDR3 memory, analog to digital capabilities, Ethernet networking, and much more that promise many exciting applications.

The DE0-Nano-SoC Development Kit contains all the tools needed to use the board in conjunction with a computer that runs the Microsoft Windows XP or later.

In addition, DE0-Nano-SoC Kit is also called Atlas-SoC Kit in Altera's Rockboard.org Linux community (<http://www.rocketboards.org/atlas-soc>). The hardware of DE0-Nano-SoC Kit and Atlas-SoC Kit are exactly the same, however, this community provides different development resource from DE0-Nano-SoC Kit. The details of kit contents can be found in the Appendix chapter.

1.1 Package Contents

Figure 1-1 shows a photograph of the DE0-Nano-SoC package.

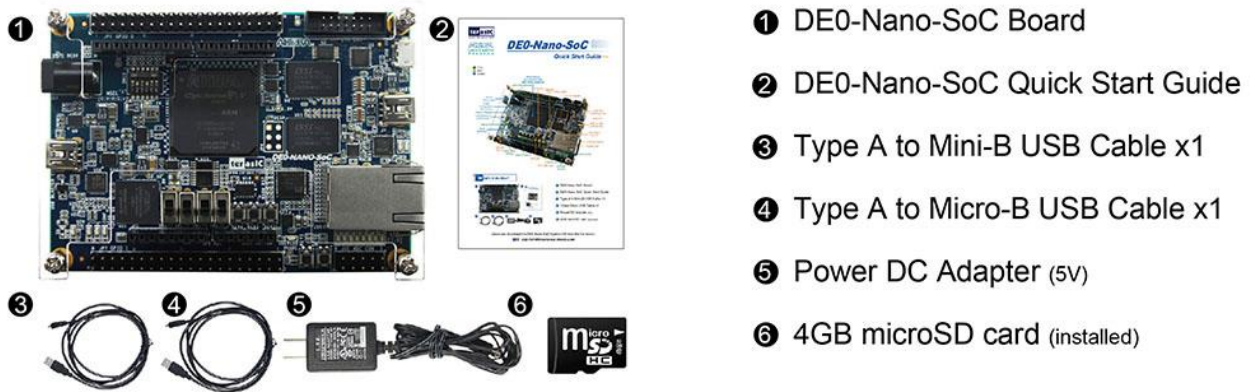

Figure 1-1 The DE0-Nano-SoC package contents

The DE0-Nano-SoC package includes:

- The DE0-Nano-SoC development board
- DE0-Nano-SoC Quick Start Guide
- USB cable Type A to Mini-B for FPGA programming or UART control
- USB cable Type A to Micro-B for USB OTG connect to PC
- 5V/2A DC power adapter
- 4GB microSD Card (Installed)

1.2 DE0-Nano-SoC System CD

The DE0-Nano-SoC System CD contains all the documents and supporting materials associated with DE0-Nano-SoC, including the user manual, system builder, reference designs, and device datasheets. Users can download this system CD from the link: <http://cd-de0-nano-soc.terasic.com>.

1.3 Getting Help

Here are the addresses where you can get help if you encounter any problems:

Altera Corporation

101 Innovation Drive San Jose, California, 95134 USA

Email: university@altera.com

Terasic Technologies

9F., No.176, Sec.2, Gongdao 5th Rd, East Dist, Hsinchu City, 30070. Taiwan

Email: support@terasic.com

Tel.: +886-3-575-0880

Website: de0-nano-soc.terasic.com

Chapter 2

Introduction of the DE0-Nano-SoC Board

This chapter provides an introduction to the features and design characteristics of the board.

2.1 Layout and Components

Figure 2-1 and Figure 2-2 shows a photograph of the board. It depicts the layout of the board and indicates the location of the connectors and key components.

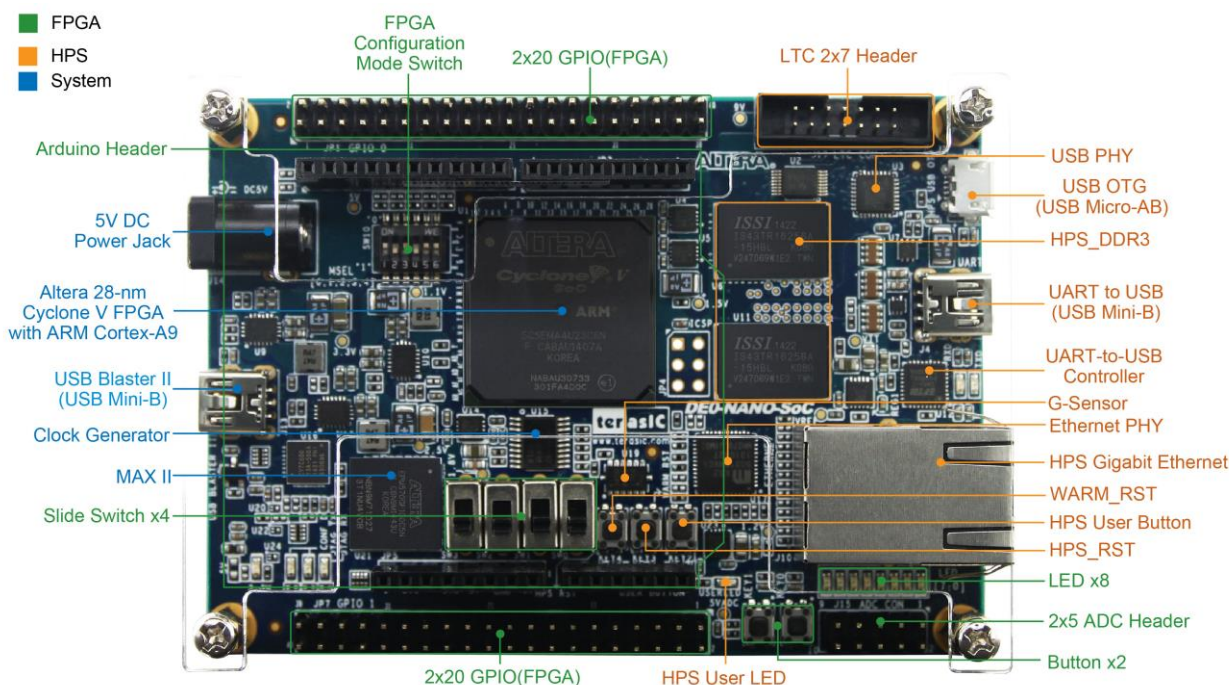

Figure 2-1 DE0-Nano-SoC development board (top view)

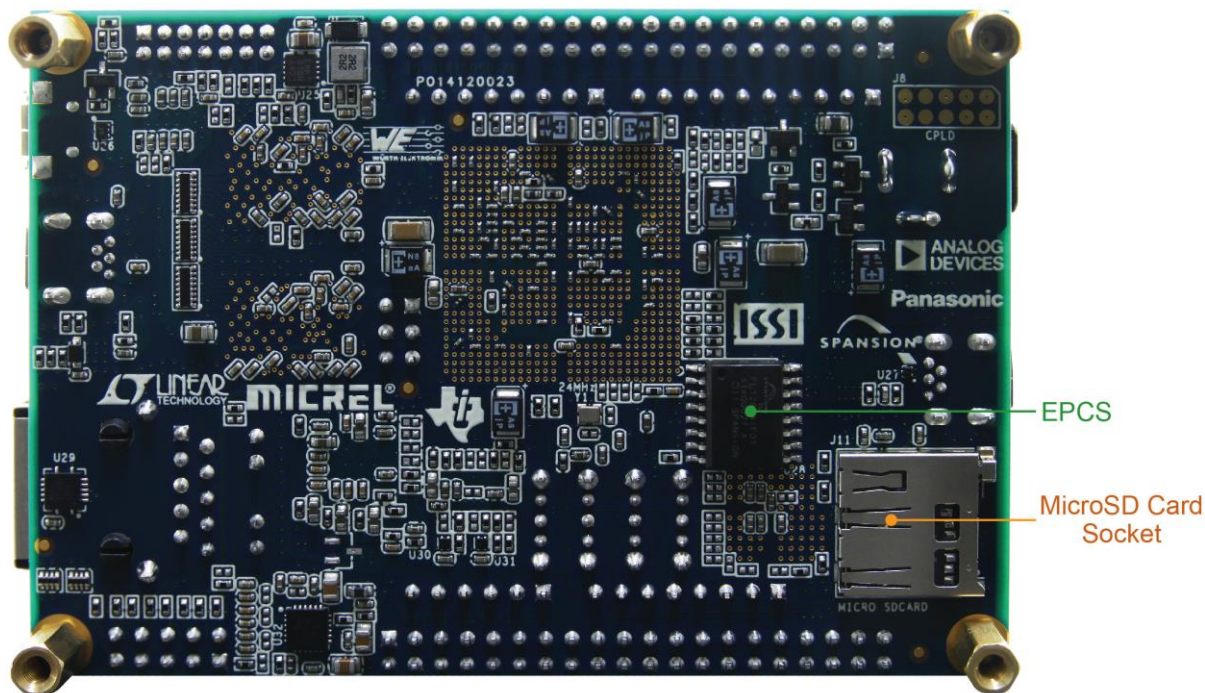

Figure 2-2 DE0-Nano-SoC development board (bottom view)

The DE0-Nano-SoC board has many features that allow users to implement a wide range of designed circuits, from simple circuits to various multimedia projects.

The following hardware is provided on the board:

■ FPGA

- Altera Cyclone® V SE 5CSEMA4U23C6N device
- Serial configuration device – EPCS
- USB-Blaster II onboard for programming; JTAG Mode
- 2 push-buttons
- 4 slide switches
- 8 green user LEDs
- Three 50MHz clock sources from the clock generator
- Two 40-pin expansion header
- One Arduino expansion header (Uno R3 compatibility), can connect with Arduino shields.
- One 10-pin Analog input expansion header. (shared with Arduino Analog input)
- A/D converter, 4-wire SPI interface with FPGA

■ HPS (Hard Processor System)

- 925MHz Dual-core ARM Cortex-A9 processor
- 1GB DDR3 SDRAM (32-bit data bus)
- 1 Gigabit Ethernet PHY with RJ45 connector
- port USB OTG, USB Micro-AB connector
- Micro SD card socket
- Accelerometer (I2C interface + interrupt)
- UART to USB, USB Mini-B connector
- Warm reset button and cold reset button
- One user button and one user LED
- LTC 2x7 expansion header

2.2 Block Diagram of the DE0-Nano-SoC Board

Figure 2-3 is the block diagram of the board. All the connections are established through the Cyclone V SoC FPGA device to provide maximum flexibility for users. Users can configure the FPGA to implement any system design.

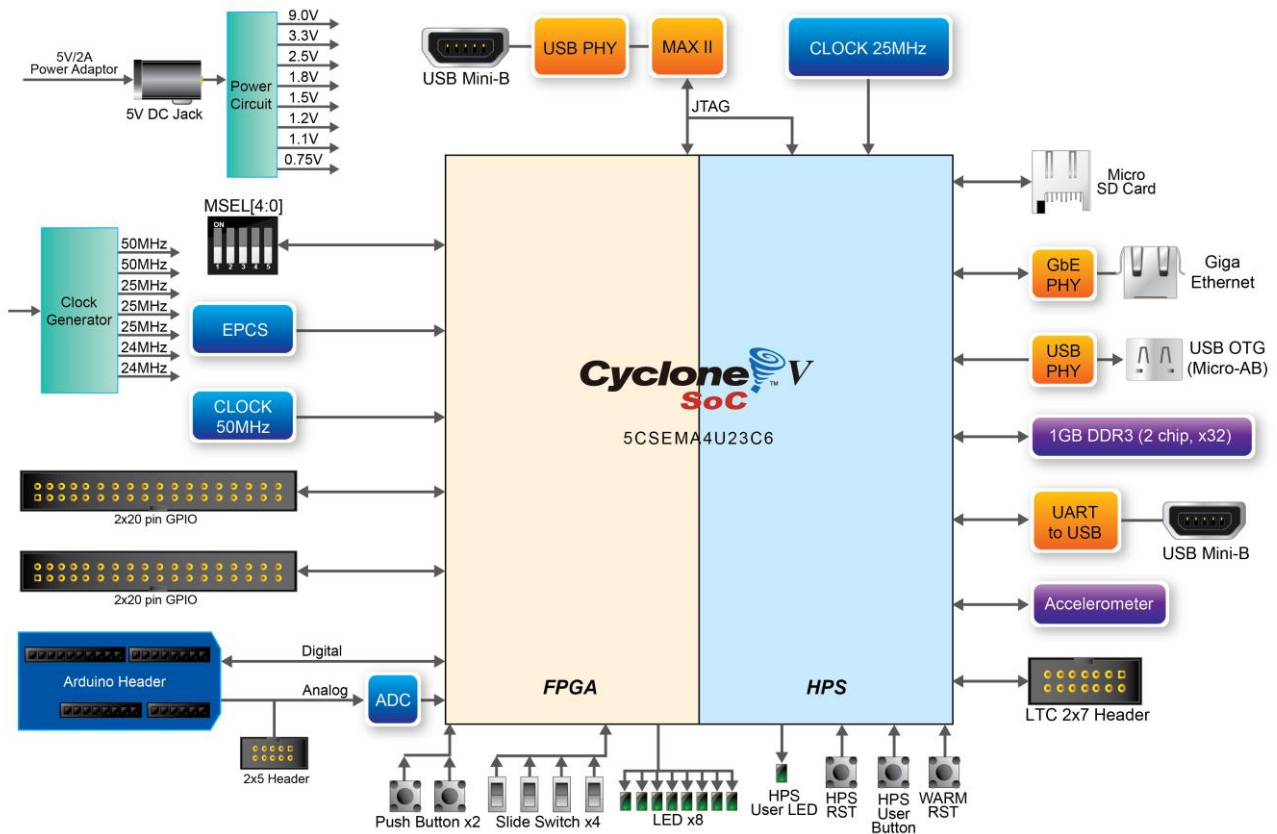

Figure 2-3 Block diagram of DE0-Nano-SoC

Detailed information about **Figure 2-3** are listed below.

FPGA Device

- Cyclone V SoC 5CSEMA4U23C6N Device
- Dual-core ARM Cortex-A9 (HPS)
- 40K programmable logic elements
- 2,460 Kbits embedded memory
- 5 fractional PLLs
- 2 hard memory controllers

Configuration and Debug

- Serial configuration device – EPCS on FPGA
- Onboard USB-Blaster II (Mini-B USB connector)

Memory Device

- 1GB (2x256Mx16) DDR3 SDRAM on HPS
- Micro SD card socket on HPS

Communication

- One USB 2.0 OTG (ULPI interface with USB Micro-AB connector)
- UART to USB (USB Mini-B connector)
- 10/100/1000 Ethernet

Connectors

- Two 40-pin expansion headers
- Arduino expansion header
- One 10-pin ADC input header
- One LTC connector (one Serial Peripheral Interface (SPI) Master ,one I2C and one GPIO interface)

ADC

- 12-Bit Resolution, 500Ksps Sampling Rate. SPI Interface.
- 8-Channel Analog Input. Input Range : 0V ~ 4.096V.

Switches, Buttons, and Indicators

- 3 user Keys (FPGA x2, HPS x1)
- 4 user switches (FPGA x4)
- 9 user LEDs (FPGA x8, HPS x 1)
- 2 HPS reset buttons (HPS_RESET_n and HPS_WARM_RST_n)

Sensors

- G-Sensor on HPS

Power

- 5V DC input

Chapter 3

Using the

DE0-Nano-SoC Board

This chapter provides an instruction to use the board and describes the peripherals.

3.1 Settings of FPGA Configuration Mode

When the DE0-Nano-SoC board is powered on, the FPGA can be configured from EPCS or HPS.

The MSEL[4:0] pins are used to select the configuration scheme. It is implemented as a 6-pin DIP switch **SW10** on the DE0-Nano-SoC board, as shown in **Figure 3-1**.

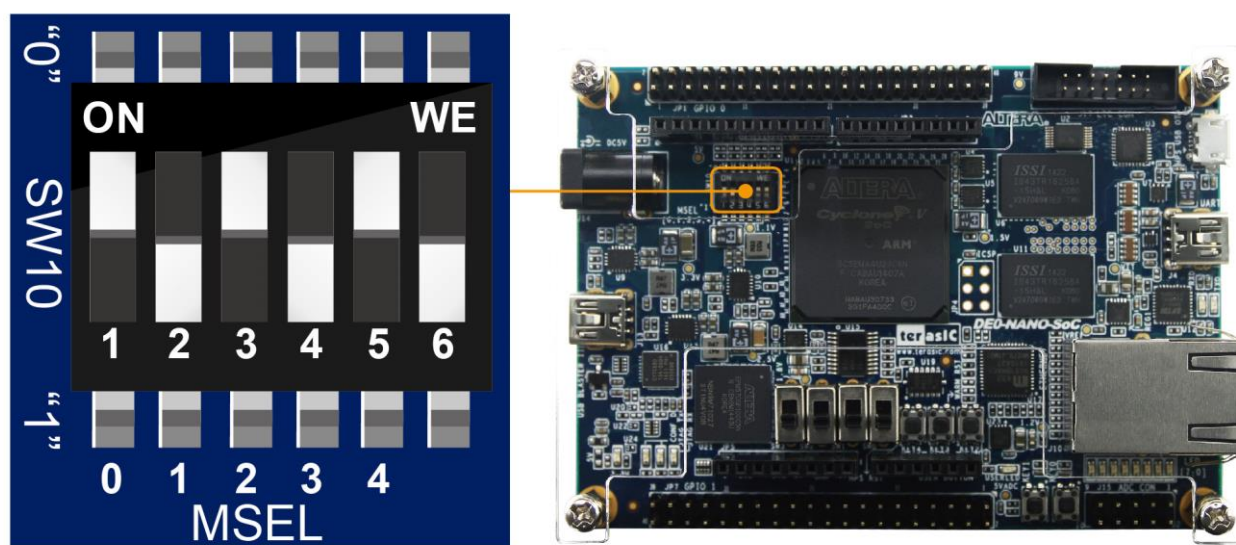

Figure 3-1 DIP switch (SW10) setting of FPP x32 mode

Table 3-1 shows the relation between MSEL[4:0] and DIP switch (SW10).

Table 3-1 FPGA Configuration Mode Switch (SW10)

Board Reference	Signal Name	Description	Default
SW10.1	MSEL0	Use these pins to set the FPGA Configuration scheme	ON ("0")
SW10.2	MSEL1		OFF ("1")
SW10.3	MSEL2		ON ("0")
SW10.4	MSEL3		OFF ("1")
SW10.5	MSEL4		ON ("0")
SW10.6	N/A	N/A	N/A

Table 3-2 shows MSEL[4:0] setting for FPGA configure, and default setting is FPPx32 mode on DE0-Nano-SoC.

When the board is powered on and MSEL[4:0] set to "10010", the FPGA is configured from EPCS, which is pre-programmed with the default code. If developers wish to configure FPGA from an application software running on Linux, the MSEL[4:0] needs to be set to "01010" before the programming process begins. If developers using the "Linux Console with frame buffer" or "Linux LXDE Desktop" SD Card image, the MSEL[4:0] needs to be set to "00000" before the board is powered on.

Table 3-2 MSEL Pin Settings for FPGA Configure of DE0-Nano-SoC

Configuration	SW10.1 MSEL0	SW10.2 MSEL1	SW10.3 MSEL2	SW10.4 MSEL3	SW10.5 MSEL4	SW10.6	Description
AS	ON	OFF	ON	ON	OFF	N/A	FPGA configured from EPCS
FPPx32 (Default)	ON	OFF	ON	OFF	ON	N/A	FPGA configured from HPS software: Linux (default)
FPPx16	ON	ON	ON	ON	ON	N/A	FPGA configured from HPS software: U-Boot, with image stored on the SD card, like LXDE Desktop or console Linux with frame buffer edition.

3.2 Configuration of Cyclone V SoC FPGA on DE0-Nano-SoC

There are two types of programming method supported by DE0-Nano-SoC:

1. JTAG programming: It is named after the IEEE standards Joint Test Action Group.

The configuration bit stream is downloaded directly into the Cyclone V SoC FPGA. The FPGA will retain its current status as long as the power keeps applying to the board; the configuration information will be lost when the power is off.

2. AS programming: The other programming method is Active Serial configuration.

The configuration bit stream is downloaded into the serial configuration device (EPCS), which provides non-volatile storage for the bit stream. The information is retained within EPCS even if the DE0-Nano-SoC board is turned off. When the board is powered on, the configuration data in the EPCS device is automatically loaded into the Cyclone V SoC FPGA.

■ JTAG Chain on DE0-Nano-SoC Board

The FPGA device can be configured through JTAG interface on DE0-Nano-SoC board, but the JTAG chain must form a closed loop, which allows Quartus II programmer to detect FPGA device. **Figure 3-2** illustrates the JTAG chain on DE0-Nano-SoC board.

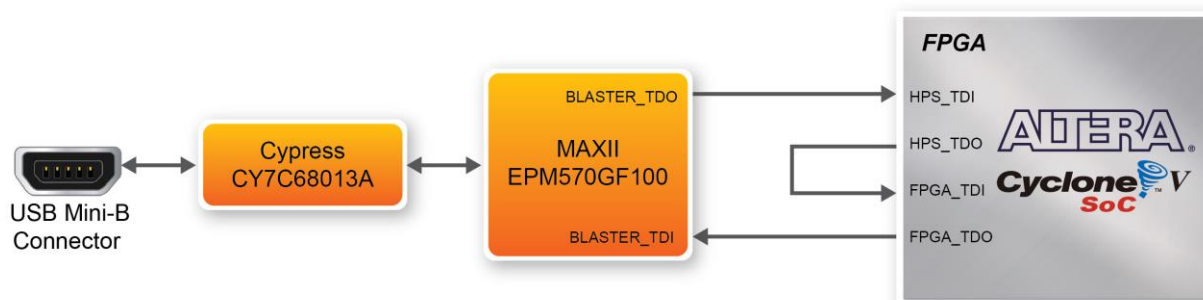

Figure 3-2 Path of the JTAG chain

■ Configure the FPGA in JTAG Mode

There are two devices (FPGA and HPS) on the JTAG chain. The following shows how the FPGA is programmed in JTAG mode step by step.

Open the Quartus II programmer and click “Auto Detect”, as circled in **Figure 3-3**

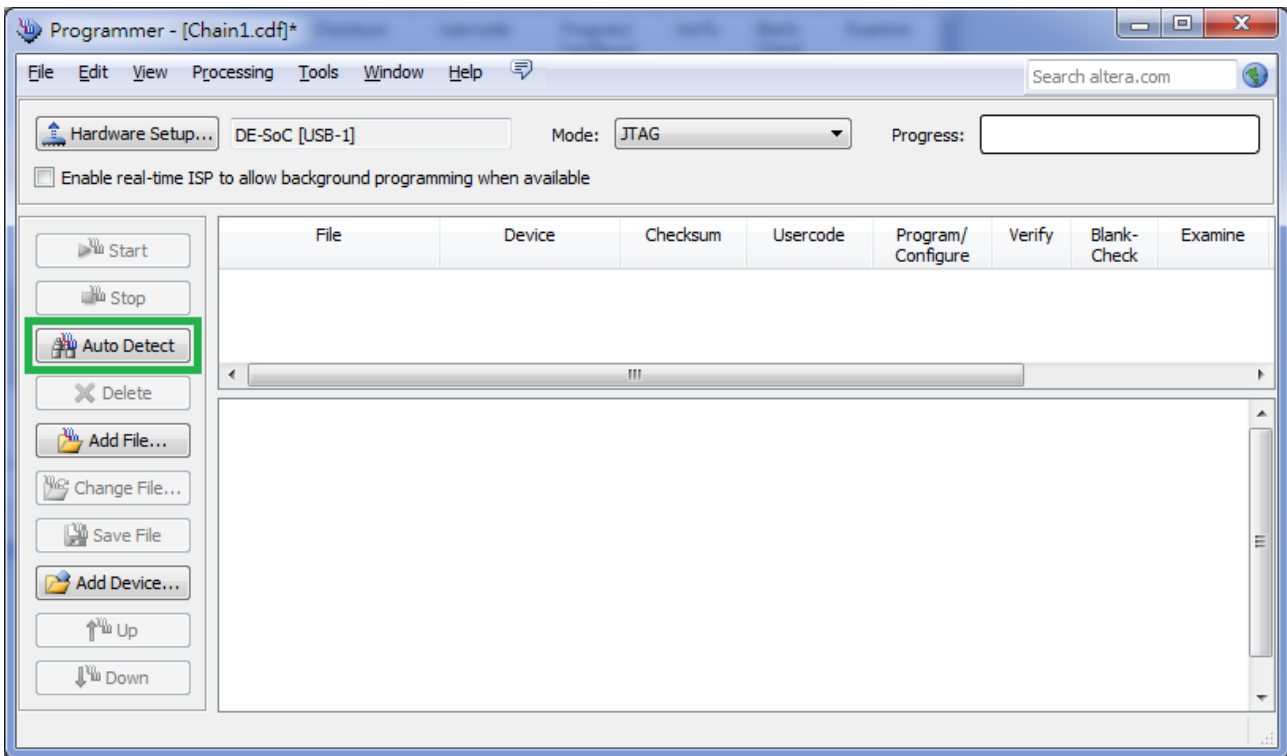

Figure 3-3 Detect FPGA device in JTAG mode

Select detected device associated with the board, as circled in **Figure 3-4**.

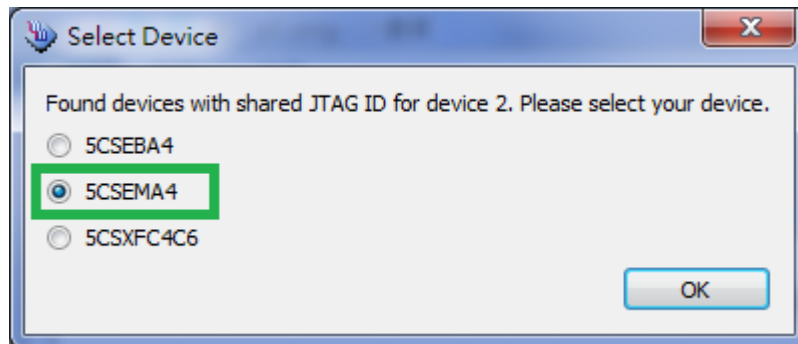

Figure 3-4 Select 5CSEMA4 device

Both FPGA and HPS are detected, as shown in **Figure 3-5**.

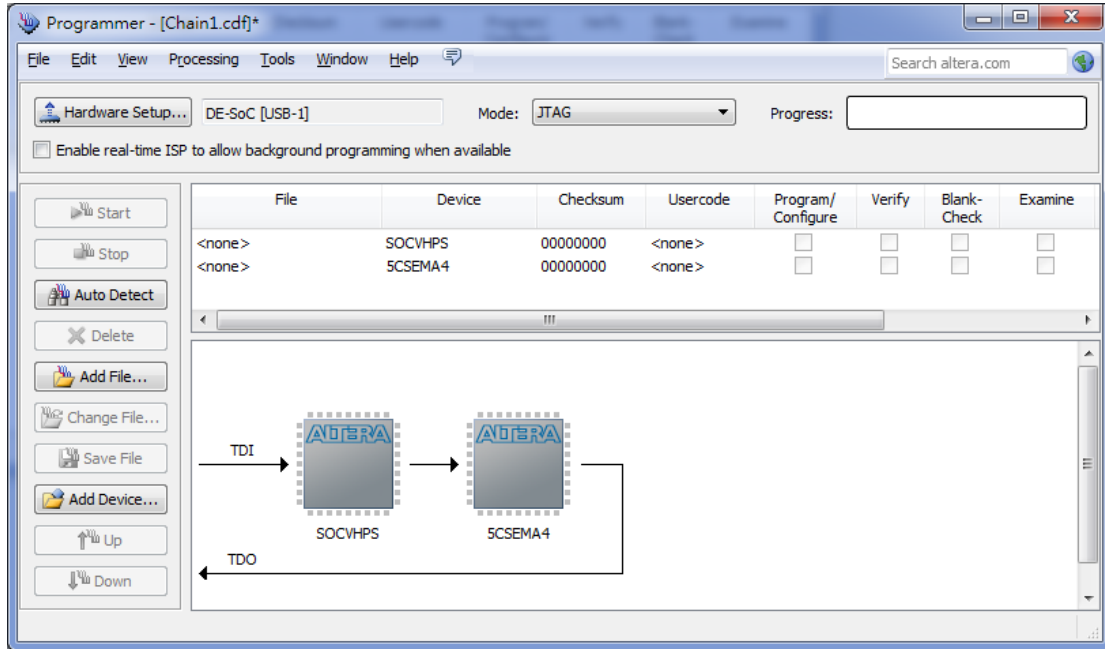

Figure 3-5 FPGA and HPS detected in Quartus programmer

Right click on the FPGA device and open the .sof file to be programmed, as highlighted in **Figure 3-6**.

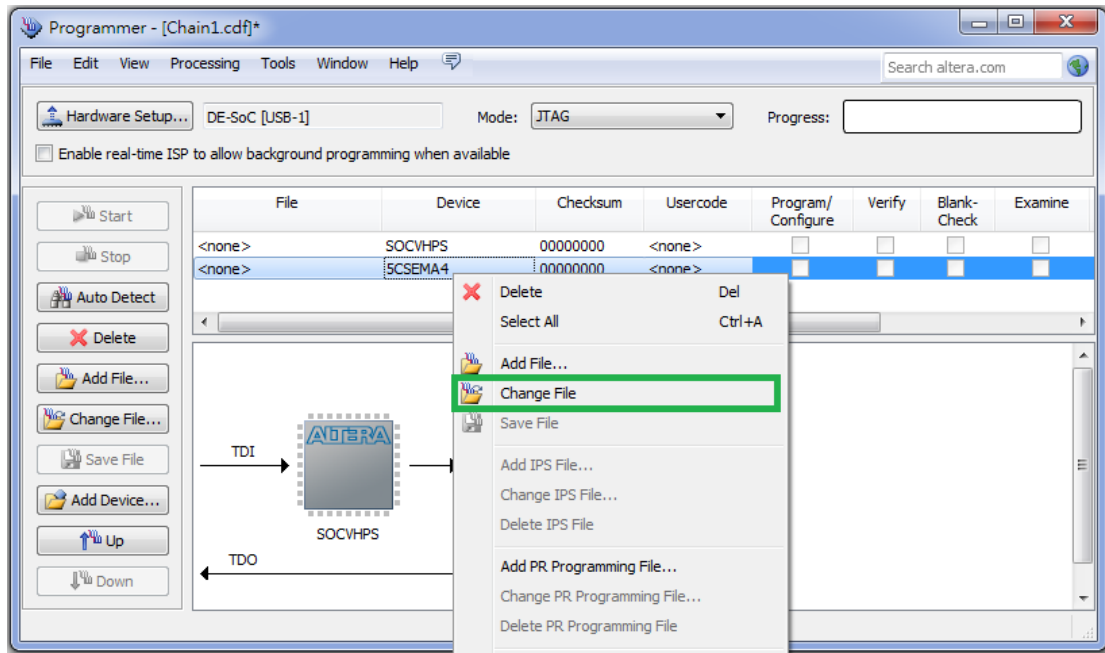

Figure 3-6 Open the .sof file to be programmed into the FPGA device

Select the .sof file to be programmed, as shown in **Figure 3-7**.

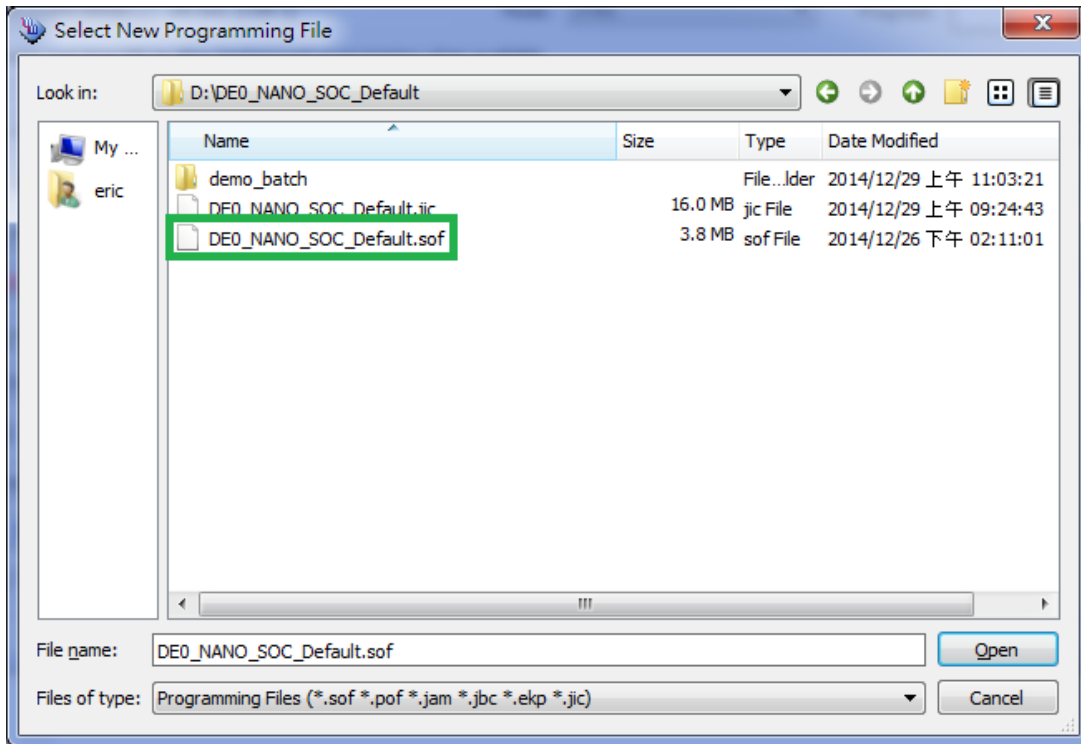

Figure 3-7 Select the .sof file to be programmed into the FPGA device

Click “Program/Configure” check box and then click “Start” button to download the .sof file into the FPGA device, as shown in **Figure 3-8**.

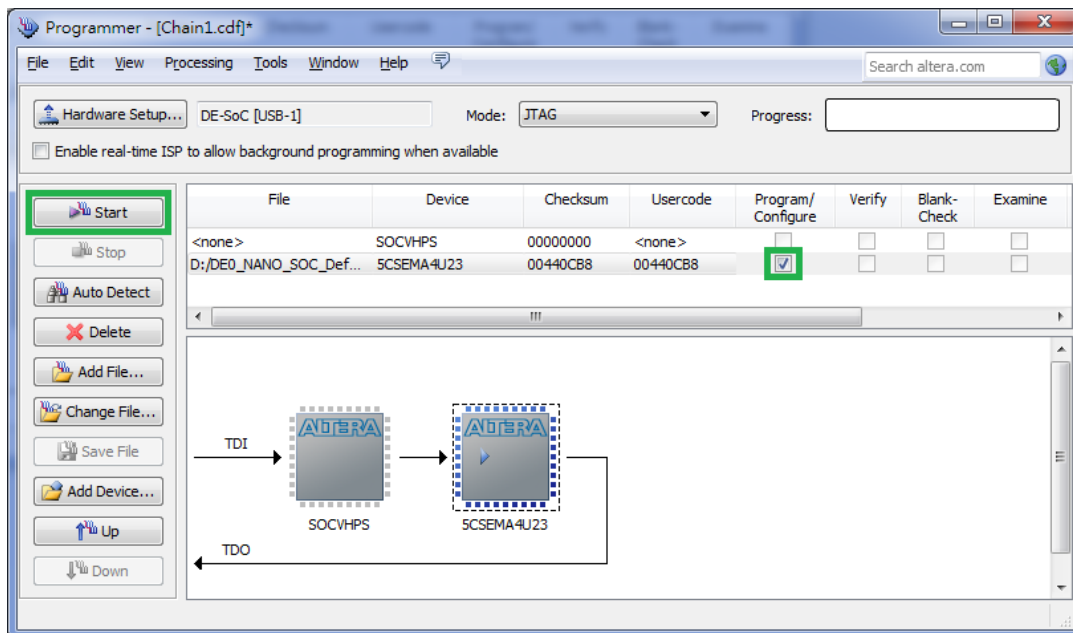

Figure 3-8 Program .sof file into the FPGA device

■ Configure the FPGA in AS Mode

The DE0-Nano-SoC board uses a serial configuration device (EPCS) to store configuration data for the Cyclone V SoC FPGA. This configuration data is automatically loaded from the serial configuration device chip into the FPGA when the board is powered up.

Users need to use Serial Flash Loader (SFL) to program the serial configuration device via JTAG interface. The FPGA-based SFL is a soft intellectual property (IP) core within the FPGA that bridge the JTAG and Flash interfaces. The SFL Megafunction is available in Quartus II. **Figure 3-9** shows the programming method when adopting SFL solution.

Please refer to Chapter 8: Steps of Programming the Serial Configuration Device for the basic programming instruction on the serial configuration device.

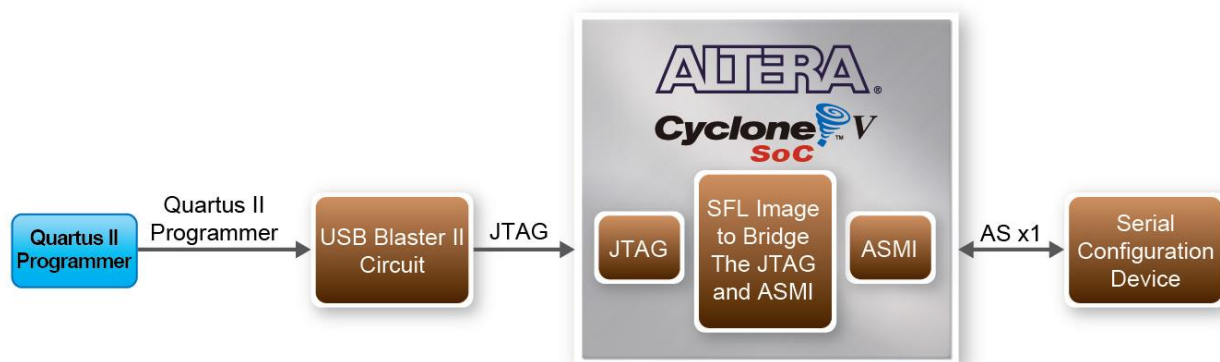

Figure 3-9 Programming a serial configuration device with SFL solution

3.3 Board Status Elements

In addition to the 9 LEDs that FPGA/HPS device can control, there are 6 indicators which can indicate the board status (See **Figure 3-10**), please refer the details in **Table 3-3**

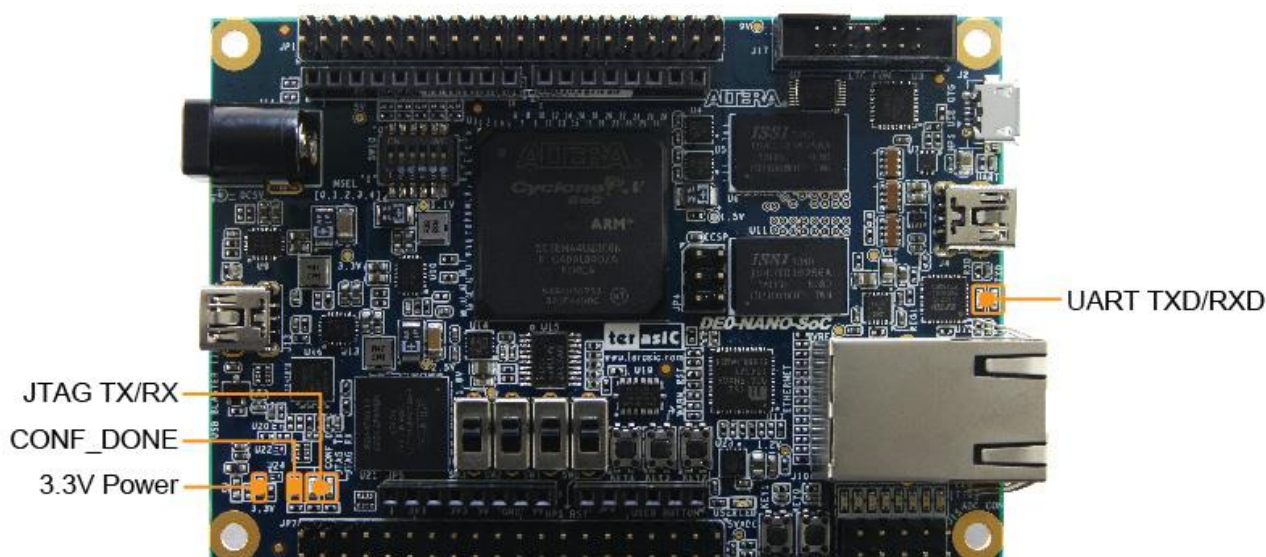

Figure 3-10 LED Indicators on DE0-Nano-SoC

Table 3-3 LED Indicators

<i>Board Reference</i>	<i>LED Name</i>	<i>Description</i>
LED9	3.3-V Power	Illuminate when 3.3V power is active.
LED10	CONF_DONE	Illuminates when the FPGA is successfully configured.
LED11	JTAG_TX	Illuminate when data is transferred from JTAG to USB Host.
LED12	JTAG_RX	Illuminate when data is transferred from USB Host to JTAG.
TXD	UART TXD	Illuminate when data is transferred from FT232R to USB Host.
RXD	UART RXD	Illuminate when data is transferred from USB Host to FT232R.

3.4 Board Reset Elements

There are two HPS reset buttons on DE0-Nano-SoC, HPS (cold) reset and HPS warm reset, as shown in **Figure 3-11**. **Table 3-4** describes the purpose of these two HPS reset buttons. **Figure 3-12** is the reset tree for DE0-Nano-SoC.

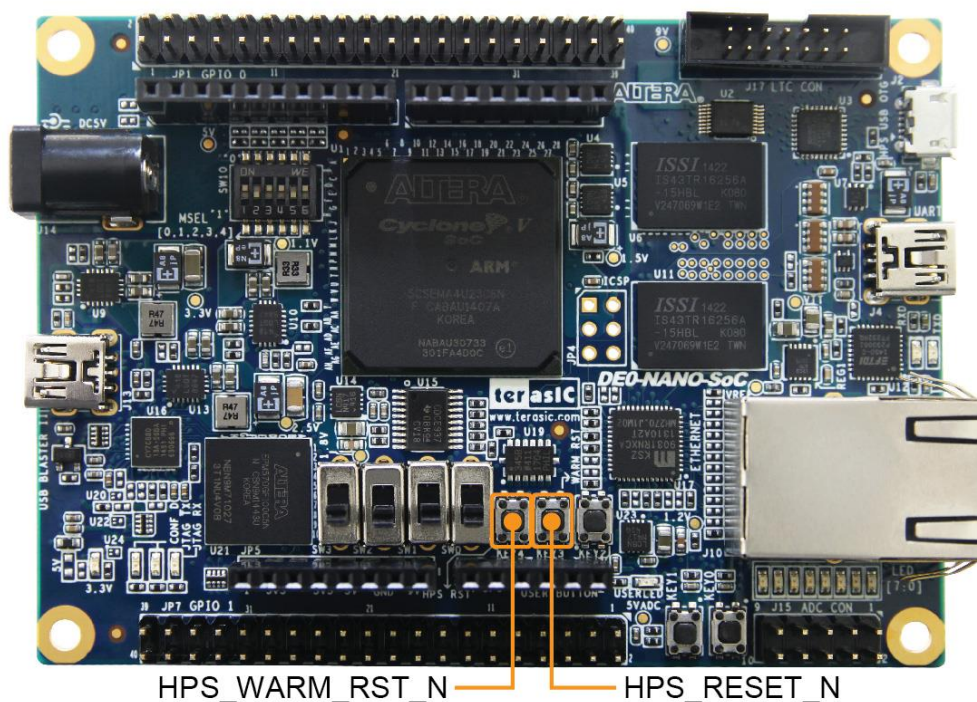

Figure 3-11 HPS cold reset and warm reset buttons on DE0-Nano-SoC

Table 3-4 Description of Two HPS Reset Buttons on DE0-Nano-SoC

<i>Board Reference</i>	<i>Signal Name</i>	<i>Description</i>
KEY4	HPS_RESET_N	Cold reset to the HPS, Ethernet PHY and USB host device. Active low input which resets all HPS logics that can be reset.
KEY3	HPS_WARM_RST_N	Warm reset to the HPS block. Active low input affects the system reset domain for debug purpose.

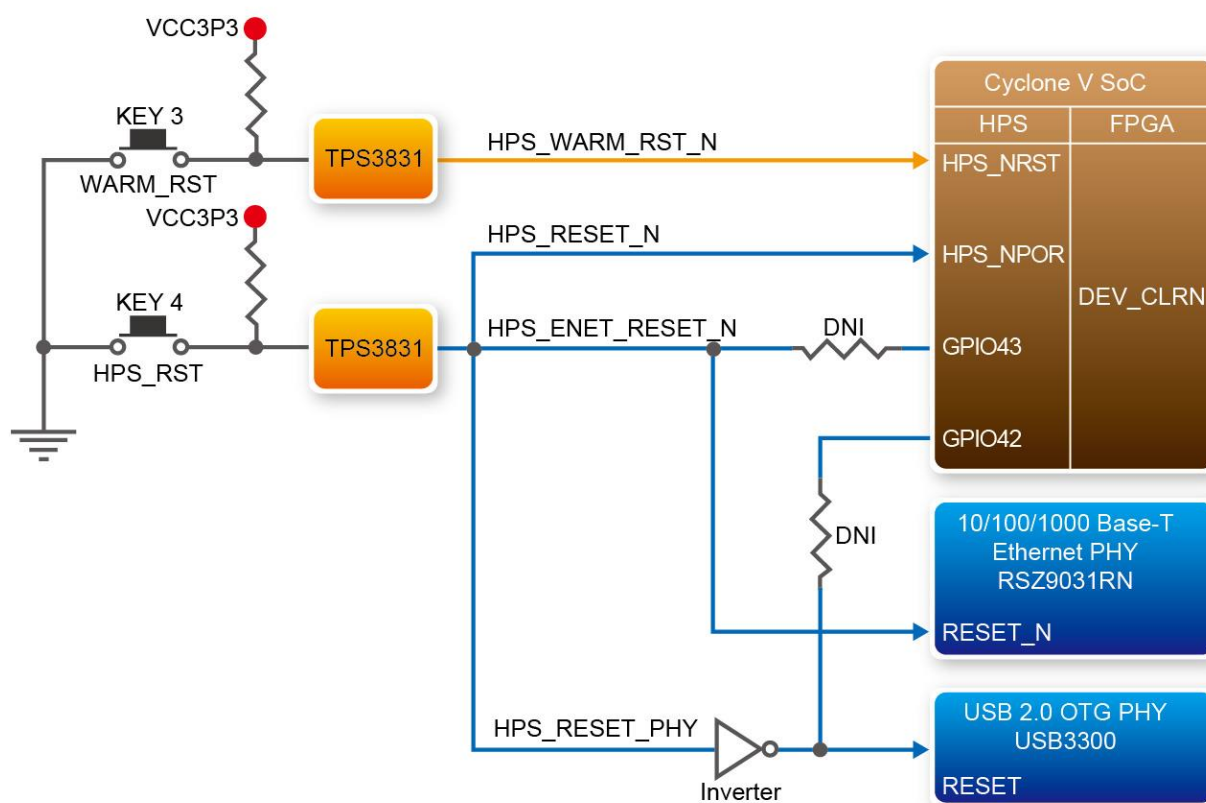

Figure 3-12 HPS reset tree on DE0-Nano-SoC board

3.5 Clock Circuitry

Figure 3-13 shows the default frequency of all external clocks to the Cyclone V SoC FPGA. A clock generator is used to distribute clock signals with low jitter. The two 50MHz clock signals connected to the FPGA are used as clock sources for user logic. Three 25MHz clock signal are connected to two HPS clock inputs, and the other one is connected to the clock input of Gigabit Ethernet Transceiver. One 24MHz clock signal is connected to the USB controller for USB Blaster II circuit and FPGA. One 24MHz clock signals are connected to the clock inputs of USB OTG PHY. The associated pin assignment for clock inputs to FPGA I/O pins is listed in Table 3-5.

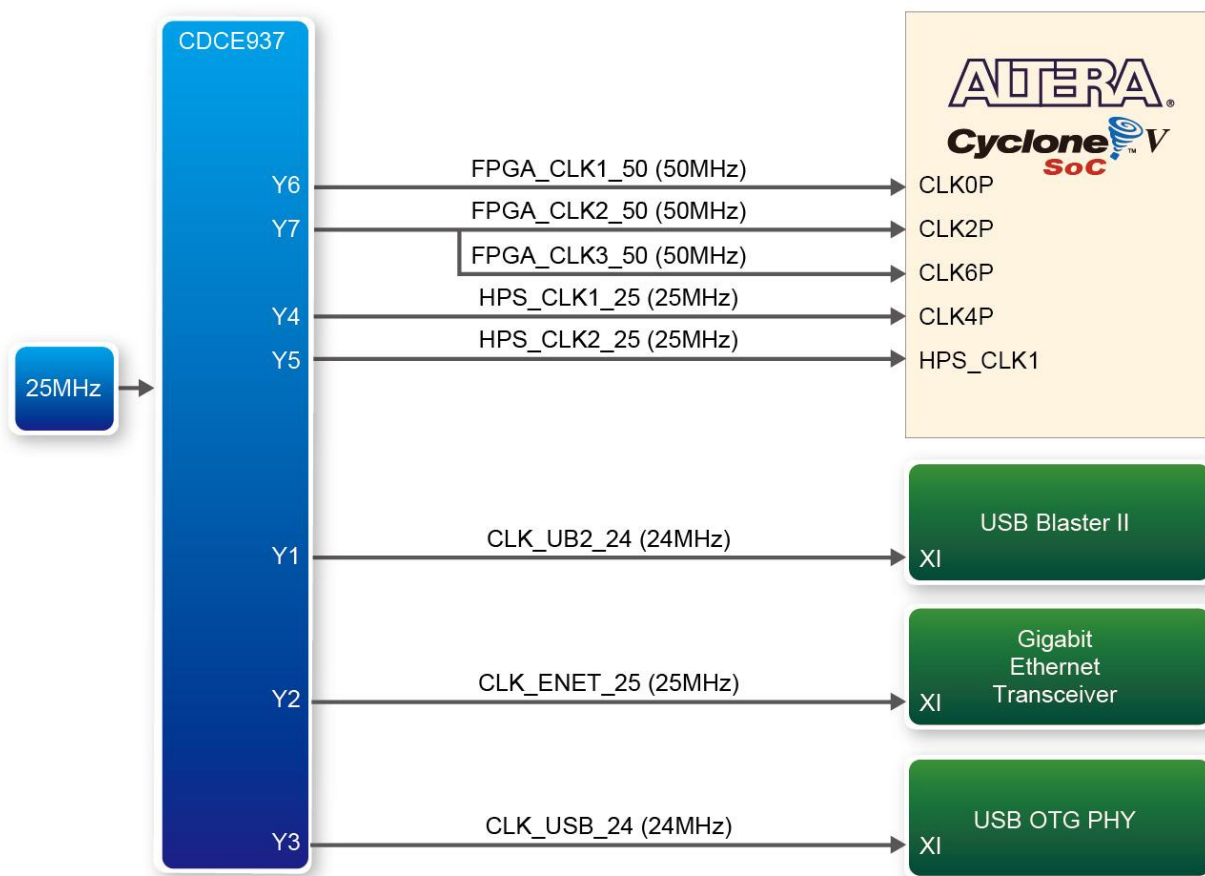

Figure 3-13 Block diagram of the clock distribution on DE0-Nano-SoC

Table 3-5 Pin Assignment of Clock Inputs

Signal Name	FPGA Pin No.	Description	I/O Standard
FPGA_CLK1_50	PIN_V11	50 MHz clock input	3.3V
FPGA_CLK2_50	PIN_Y13	50 MHz clock input	3.3V
FPGA_CLK3_50	PIN_E11	50 MHz clock input (share with FPGA_CLK1_50)	3.3V
HPS_CLK1_25	PIN_E20	25 MHz clock input	3.3V
HPS_CLK2_25	PIN_D20	25 MHz clock input	3.3V

3.6 Peripherals Connected to the FPGA

This section describes the interfaces connected to the FPGA. Users can control or monitor different interfaces with user logic from the FPGA.

3.6.1 User Push-buttons, Switches and LEDs

The board has two push-buttons connected to the FPGA, as shown in **Figure 3-14** Connections between the push-buttons and the Cyclone V SoC FPGA. Schmitt trigger circuit is implemented and act as switch debounce in **Figure 3-15** for the push-buttons connected. The two push-buttons named KEY0 and KEY1 coming out of the Schmitt trigger device are connected directly to the Cyclone V SoC FPGA. The push-button generates a low logic level or high logic level when it is pressed or not, respectively. Since the push-buttons are debounced, they can be used as clock or reset inputs in a circuit.

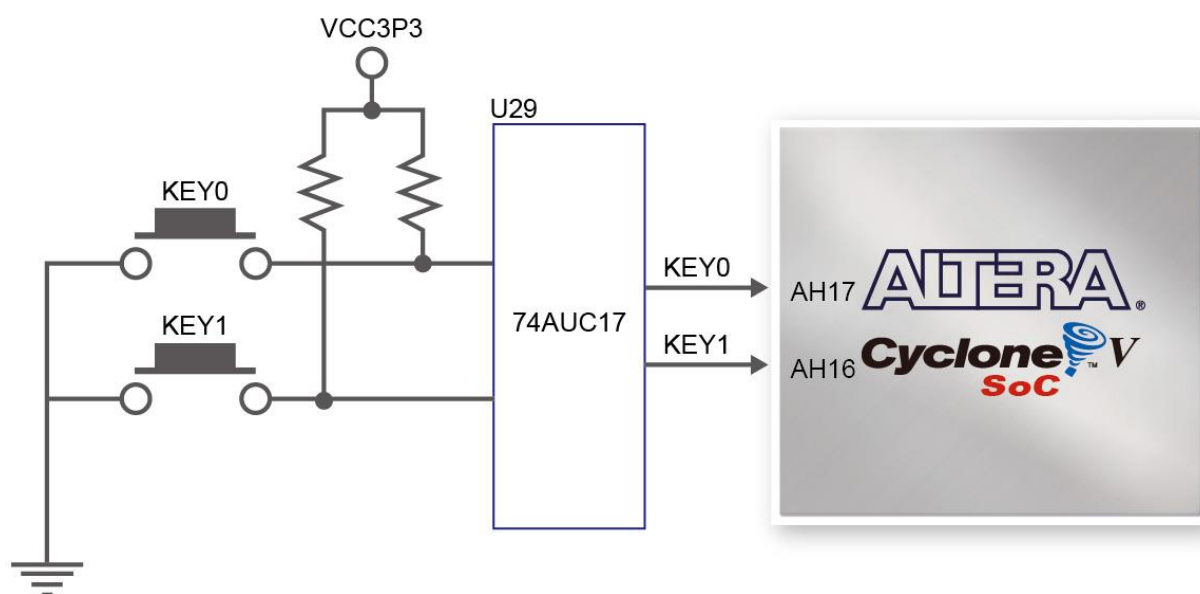

Figure 3-14 Connections between the push-buttons and the Cyclone V SoC FPGA

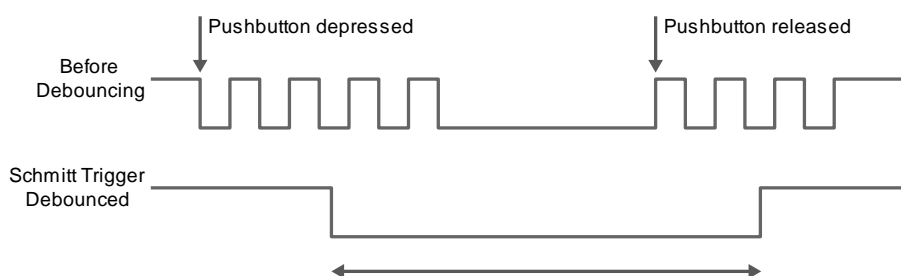

Figure 3-15 Switch debouncing

There are four slide switches connected to the FPGA, as shown in **Figure 3-16**. These switches are

not debounced and to be used as level-sensitive data inputs to a circuit. Each switch is connected directly and individually to the FPGA. When the switch is set to the DOWN position (towards the edge of the board), it generates a low logic level to the FPGA. When the switch is set to the UP position, a high logic level is generated to the FPGA.

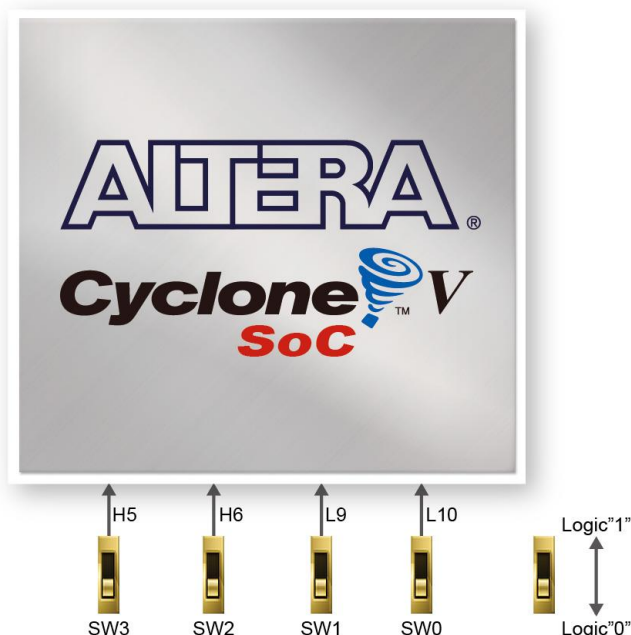

Figure 3-16 Connections between the slide switches and the Cyclone V SoC FPGA

There are also eight user-controllable LEDs connected to the FPGA. Each LED is driven directly and individually by the Cyclone V SoC FPGA; driving its associated pin to a high logic level or low level to turn the LED on or off, respectively. **Figure 3-17** shows the connections between LEDs and Cyclone V SoC FPGA. **Table 3-6**, **Table 3-7** and **Table 3-8** list the pin assignment of user push-buttons, switches, and LEDs.

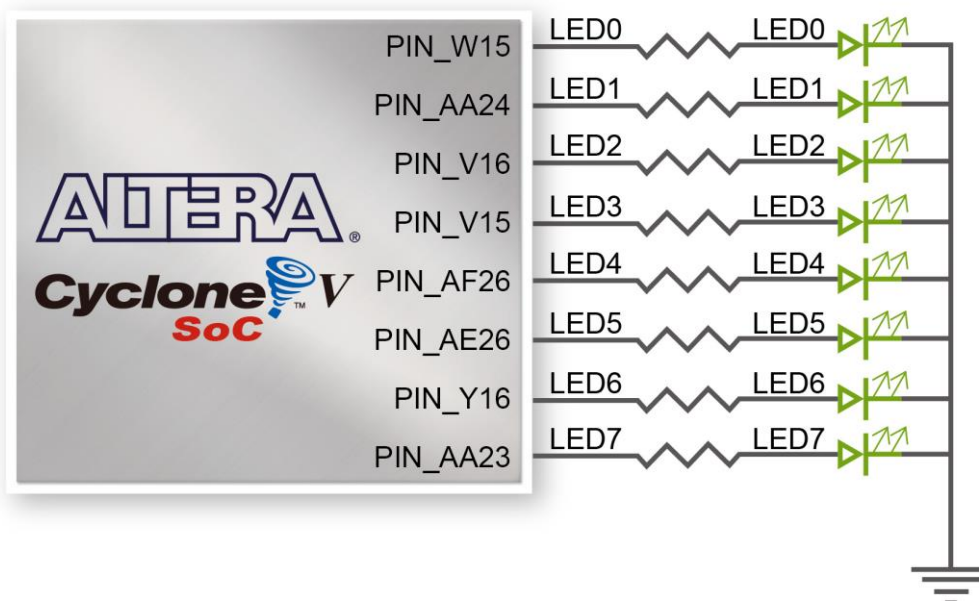

Figure 3-17 Connections between the LEDs and the Cyclone V SoC FPGA

Table 3-6 Pin Assignment of Slide Switches

Signal Name	FPGA Pin No.	Description	I/O Standard
SW[0]	PIN_L10	Slide Switch[0]	3.3V
SW[1]	PIN_L9	Slide Switch[1]	3.3V
SW[2]	PIN_H6	Slide Switch[2]	3.3V
SW[3]	PIN_H5	Slide Switch[3]	3.3V

Table 3-7 Pin Assignment of Push-buttons

Signal Name	FPGA Pin No.	Description	I/O Standard
KEY[0]	PIN_AH17	Push-button[0]	3.3V
KEY[1]	PIN_AH16	Push-button[1]	3.3V

Table 3-8 Pin Assignment of LEDs

Signal Name	FPGA Pin No.	Description	I/O Standard
LED[0]	PIN_W15	LED [0]	3.3V
LED[1]	PIN_AA24	LED [1]	3.3V
LED[2]	PIN_V16	LED [2]	3.3V
LED[3]	PIN_V15	LED [3]	3.3V
LED[4]	PIN_AF26	LED [4]	3.3V
LED[5]	PIN_AE26	LED [5]	3.3V
LED[6]	PIN_Y16	LED [6]	3.3V
LED[7]	PIN_AA23	LED [7]	3.3V

3.6.2 2x20 GPIO Expansion Headers

The board has two 40-pin expansion headers. Each header has 36 user pins connected directly to the Cyclone V SoC FPGA. It also comes with DC +5V (VCC5), DC +3.3V (VCC3P3), and two GND pins. **Figure 3-18** shows the I/O distribution of the GPIO connector. The maximum power consumption allowed for a daughter card connected to one or two GPIO ports is shown in **Table 3-9** and **Table 3-10** shows all the pin assignments of the GPIO connector.

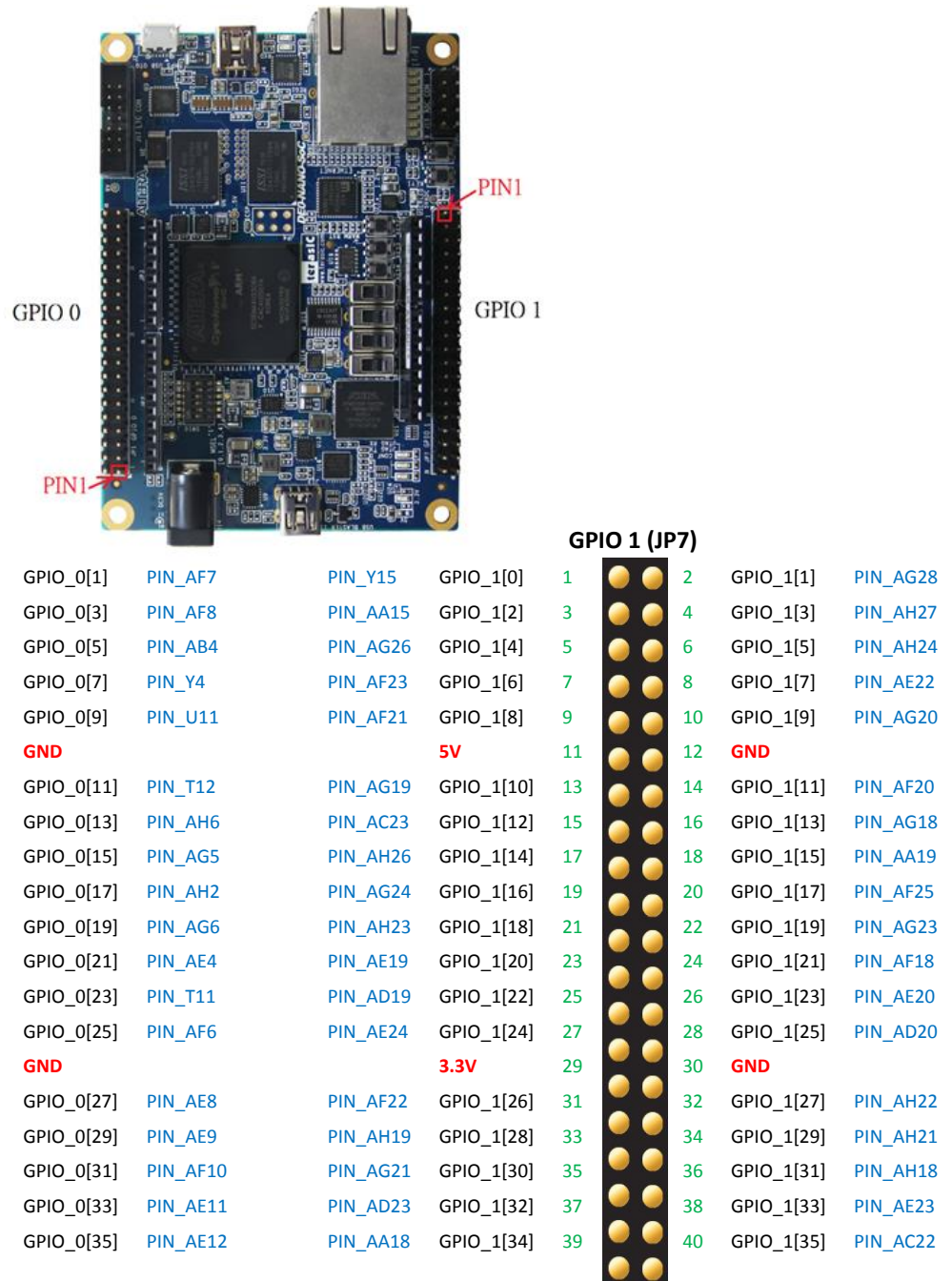

Figure 3-18 GPIO Pin Arrangement

Table 3-9 Voltage and Max. Current Limit of Expansion Header(s)

<i>Supplied Voltage</i>	<i>Max. Current Limit</i>
5V	1A (depend on the power adapter specification.)
3.3V	1.5A

Table 3-10 Show all Pin Assignment of Expansion Headers

<i>Signal Name</i>	<i>FPGA Pin No.</i>	<i>Description</i>	<i>I/O Standard</i>
GPIO_0[0]	PIN_V12	GPIO Connection 0[0]	3.3V
GPIO_0[1]	PIN_AF7	GPIO Connection 0[1]	3.3V
GPIO_0[2]	PIN_W12	GPIO Connection 0[2]	3.3V
GPIO_0[3]	PIN_AF8	GPIO Connection 0[3]	3.3V
GPIO_0[4]	PIN_Y8	GPIO Connection 0[4]	3.3V
GPIO_0[5]	PIN_AB4	GPIO Connection 0[5]	3.3V
GPIO_0[6]	PIN_W8	GPIO Connection 0[6]	3.3V
GPIO_0[7]	PIN_Y4	GPIO Connection 0[7]	3.3V
GPIO_0[8]	PIN_Y5	GPIO Connection 0[8]	3.3V
GPIO_0[9]	PIN_U11	GPIO Connection 0[9]	3.3V
GPIO_0[10]	PIN_T8	GPIO Connection 0[10]	3.3V
GPIO_0[11]	PIN_T12	GPIO Connection 0[11]	3.3V
GPIO_0[12]	PIN_AH5	GPIO Connection 0[12]	3.3V
GPIO_0[13]	PIN_AH6	GPIO Connection 0[13]	3.3V
GPIO_0[14]	PIN_AH4	GPIO Connection 0[14]	3.3V
GPIO_0[15]	PIN_AG5	GPIO Connection 0[15]	3.3V
GPIO_0[16]	PIN_AH3	GPIO Connection 0[16]	3.3V
GPIO_0[17]	PIN_AH2	GPIO Connection 0[17]	3.3V
GPIO_0[18]	PIN_AF4	GPIO Connection 0[18]	3.3V
GPIO_0[19]	PIN_AG6	GPIO Connection 0[19]	3.3V
GPIO_0[20]	PIN_AF5	GPIO Connection 0[20]	3.3V
GPIO_0[21]	PIN_AE4	GPIO Connection 0[21]	3.3V
GPIO_0[22]	PIN_T13	GPIO Connection 0[22]	3.3V
GPIO_0[23]	PIN_T11	GPIO Connection 0[23]	3.3V
GPIO_0[24]	PIN_AE7	GPIO Connection 0[24]	3.3V
GPIO_0[25]	PIN_AF6	GPIO Connection 0[25]	3.3V
GPIO_0[26]	PIN_AF9	GPIO Connection 0[26]	3.3V
GPIO_0[27]	PIN_AE8	GPIO Connection 0[27]	3.3V
GPIO_0[28]	PIN_AD10	GPIO Connection 0[28]	3.3V
GPIO_0[29]	PIN_AE9	GPIO Connection 0[29]	3.3V
GPIO_0[30]	PIN_AD11	GPIO Connection 0[30]	3.3V
GPIO_0[31]	PIN_AF10	GPIO Connection 0[31]	3.3V
GPIO_0[32]	PIN_AD12	GPIO Connection 0[32]	3.3V
GPIO_0[33]	PIN_AE11	GPIO Connection 0[33]	3.3V
GPIO_0[34]	PIN_AF11	GPIO Connection 0[34]	3.3V
GPIO_0[35]	PIN_AE12	GPIO Connection 0[35]	3.3V

GPIO_1[0]	PIN_Y15	GPIO Connection 1[0]	3.3V
GPIO_1[1]	PIN_AG28	GPIO Connection 1[1]	3.3V
GPIO_1[2]	PIN_AA15	GPIO Connection 1[2]	3.3V
GPIO_1[3]	PIN_AH27	GPIO Connection 1[3]	3.3V
GPIO_1[4]	PIN_AG26	GPIO Connection 1[4]	3.3V
GPIO_1[5]	PIN_AH24	GPIO Connection 1[5]	3.3V
GPIO_1[6]	PIN_AF23	GPIO Connection 1[6]	3.3V
GPIO_1[7]	PIN_AE22	GPIO Connection 1[7]	3.3V
GPIO_1[8]	PIN_AF21	GPIO Connection 1[8]	3.3V
GPIO_1[9]	PIN_AG20	GPIO Connection 1[9]	3.3V
GPIO_1[10]	PIN_AG19	GPIO Connection 1[10]	3.3V
GPIO_1[11]	PIN_AF20	GPIO Connection 1[11]	3.3V
GPIO_1[12]	PIN_AC23	GPIO Connection 1[12]	3.3V
GPIO_1[13]	PIN_AG18	GPIO Connection 1[13]	3.3V
GPIO_1[14]	PIN_AH26	GPIO Connection 1[14]	3.3V
GPIO_1[15]	PIN_AA19	GPIO Connection 1[15]	3.3V
GPIO_1[16]	PIN_AG24	GPIO Connection 1[16]	3.3V
GPIO_1[17]	PIN_AF25	GPIO Connection 1[17]	3.3V
GPIO_1[18]	PIN_AH23	GPIO Connection 1[18]	3.3V
GPIO_1[19]	PIN_AG23	GPIO Connection 1[19]	3.3V
GPIO_1[20]	PIN_AE19	GPIO Connection 1[20]	3.3V
GPIO_1[21]	PIN_AF18	GPIO Connection 1[21]	3.3V
GPIO_1[22]	PIN_AD19	GPIO Connection 1[22]	3.3V
GPIO_1[23]	PIN_AE20	GPIO Connection 1[23]	3.3V
GPIO_1[24]	PIN_AE24	GPIO Connection 1[24]	3.3V
GPIO_1[25]	PIN_AD20	GPIO Connection 1[25]	3.3V
GPIO_1[26]	PIN_AF22	GPIO Connection 1[26]	3.3V
GPIO_1[27]	PIN_AH22	GPIO Connection 1[27]	3.3V
GPIO_1[28]	PIN_AH19	GPIO Connection 1[28]	3.3V
GPIO_1[29]	PIN_AH21	GPIO Connection 1[29]	3.3V
GPIO_1[30]	PIN_AG21	GPIO Connection 1[30]	3.3V
GPIO_1[31]	PIN_AH18	GPIO Connection 1[31]	3.3V
GPIO_1[32]	PIN_AD23	GPIO Connection 1[32]	3.3V
GPIO_1[33]	PIN_AE23	GPIO Connection 1[33]	3.3V
GPIO_1[34]	PIN_AA18	GPIO Connection 1[34]	3.3V
GPIO_1[35]	PIN_AC22	GPIO Connection 1[35]	3.3V

3.6.3 Arduino Uno R3 Expansion Header

The board provides Arduino Uno revision 3 compatibility expansion header which comes with four independent headers. The expansion header has 17 user pins (16pins GPIO and 1pin Reset) connected directly to the Cyclone V SoC FPGA. 6-pins Analog input connects to ADC, and also provides DC +9V (VCC9), DC +5V (VCC5), DC +3.3V (VCC3P3 and IOREF), and three GND pins.

Please refer to **Figure 3-19** for detailed pin-out information. The blue font represents the Arduino Uno R3 board pin-out definition.

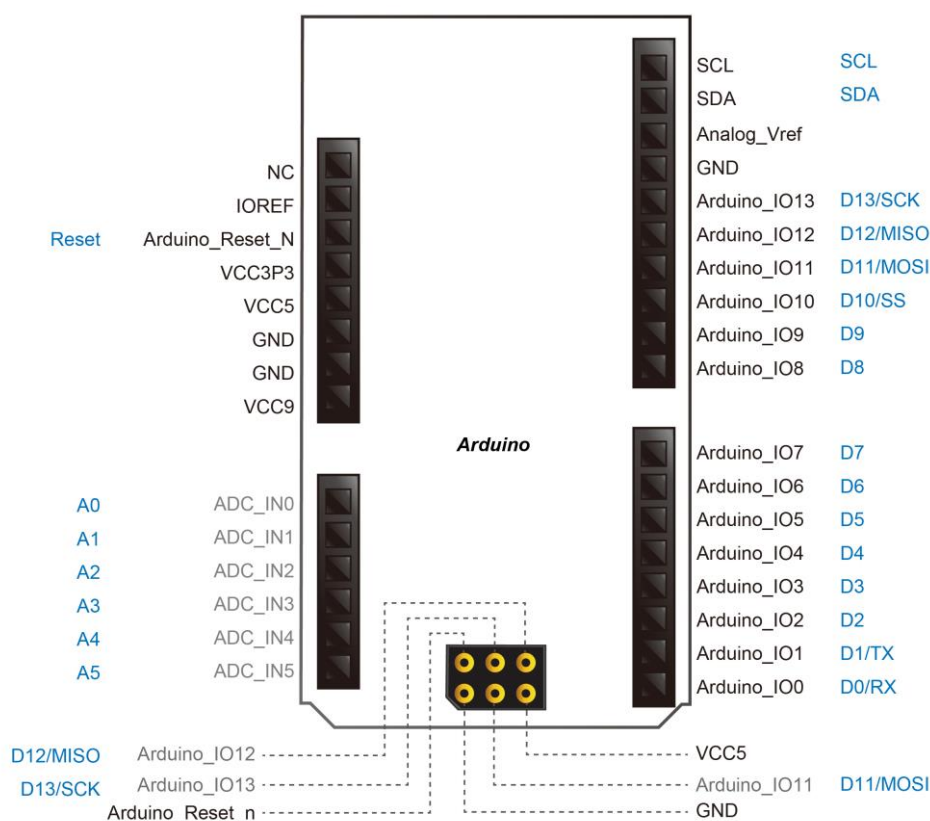

Figure 3-19 lists the all the pin-out signal name of the Arduino Uno connector. The blue font represents the Arduino pin-out definition.

The 16 GPIO pins are provided to the Arduino Header for digital I/O. **Table 3-11** lists the all the pin assignments of the Arduino Uno connector (digital), signal names relative to the Cyclone V SoC FPGA.

Table 3-11 Pin Assignments for Arduino Uno Expansion Header connector

<i>Schematic Signal Name</i>	<i>FPGA Pin No.</i>	<i>Description</i>	<i>Specific features For Arduino</i>	<i>I/O Standard</i>
Arduino_IO0	PIN_AG13	Arduino IO0	RXD	3.3-V
Arduino_IO1	PIN_AF13	Arduino IO1	TXD	3.3-V
Arduino_IO2	PIN_AG10	Arduino IO2		3.3-V
Arduino_IO3	PIN_AG9	Arduino IO3		3.3-V
Arduino_IO4	PIN_U14	Arduino IO4		3.3-V
Arduino_IO5	PIN_U13	Arduino IO5		3.3-V
Arduino_IO6	PIN_AG8	Arduino IO6		3.3-V
Arduino_IO7	PIN_AH8	Arduino IO7		3.3-V
Arduino_IO8	PIN_AF17	Arduino IO8		3.3-V
Arduino_IO9	PIN_AE15	Arduino IO9		3.3-V
Arduino_IO10	PIN_AF15	Arduino IO10	SS	3.3-V
Arduino_IO11	PIN_AG16	Arduino IO11	MOSI	3.3-V
Arduino_IO12	PIN_AH11	Arduino IO12	MISO	3.3-V
Arduino_IO13	PIN_AH12	Arduino IO13	SCK	3.3-V
Arduino_IO14	PIN_AH9	Arduino IO14	SDA	3.3-V
Arduino_IO15	PIN_AG11	Arduino IO15	SCL	3.3-V
Arduino_Reset_n	PIN_AH7	Reset signal, low active.		3.3-V

Besides 16 pins for digital GPIO, there are also 6 analog inputs on the Arduino Uno R3 Expansion Header (ADC_IN0 ~ ADC_IN5). Consequently, we use ADC LTC2308 from Linear Technology on the board for possible future analog-to-digital applications. We will introduce in the next section.

3.6.4 A/D Converter and Analog Input

The DE0-Nano-SoC has an analog-to-digital converter (LTC2308).

The LTC2308 is a low noise, 500ksps, 8-channel, 12-bit ADC with a SPI/MICROWIRE compatible serial interface. This ADC includes an internal reference and a fully differential sample-and-hold circuit to reduce common mode noise. The internal conversion clock allows the external serial output data clock (SCK) to operate at any frequency up to 40MHz.

It can be configured to accept eight input signals at inputs ADC_IN0 through ADC_IN7. These eight input signals are connected to a 2x5 header, as shown in **Figure 3-20**.

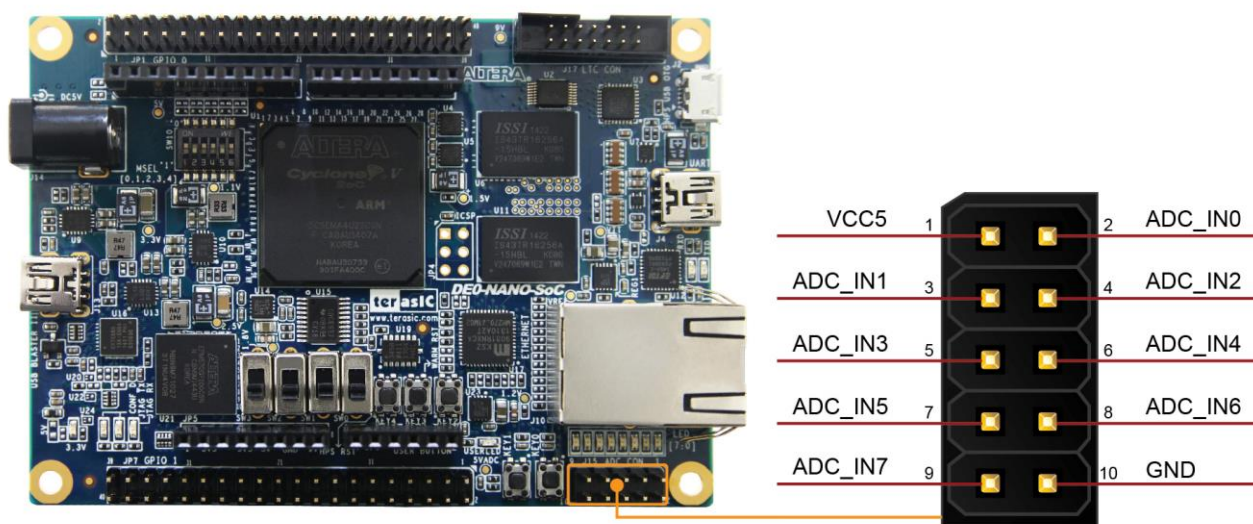

Figure 3-20 Signals of the 2x5 Header

These Analog inputs are shared with the Arduino's analog input pin (ADC_IN0 ~ ADC_IN5), **Figure 3-21** shows the connections between the FPGA, 2x5 header, Arduino Analog input, and the A/D converter.

More information about the A/D converter chip is available in its datasheet. It can be found on manufacturer's website or in the directory \Datasheet\ADC of DE0-Nano-SoC system CD.

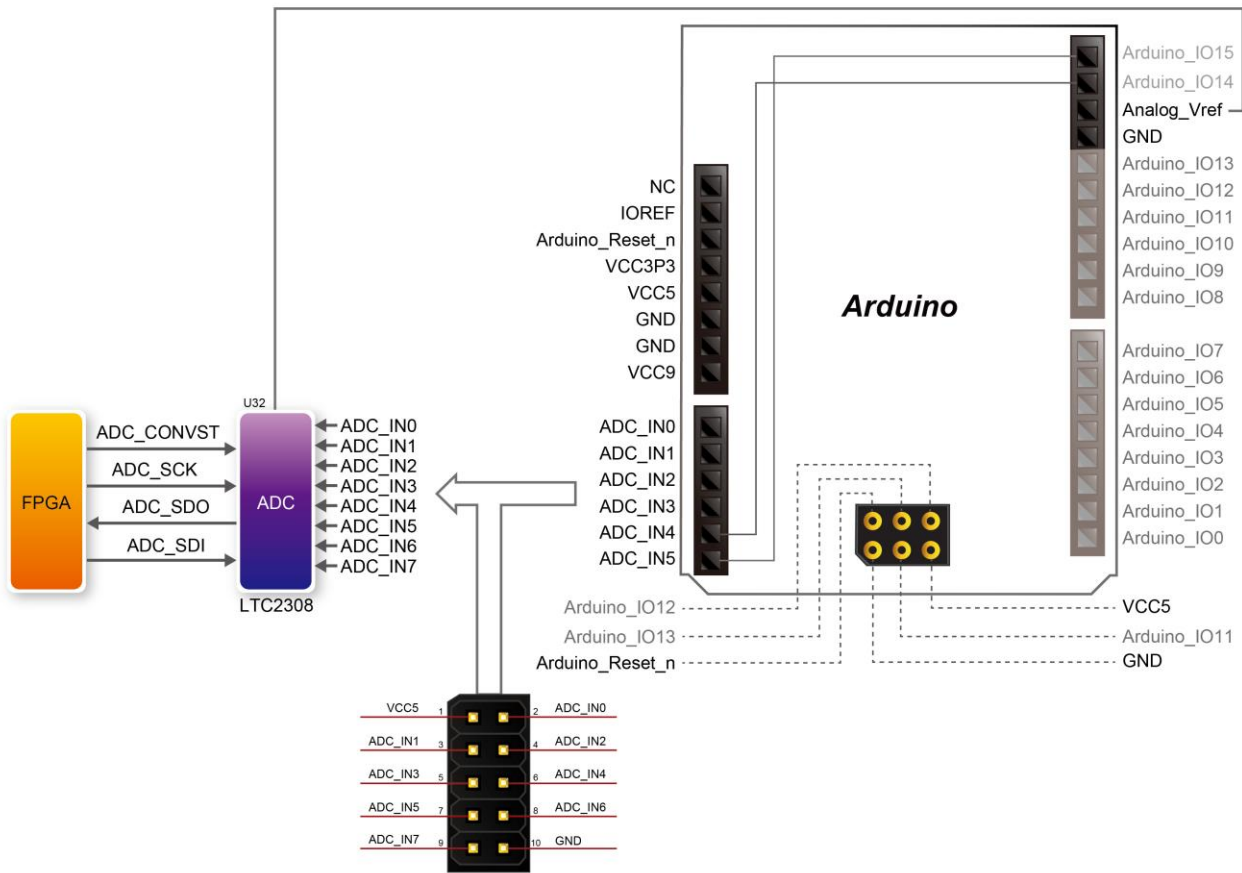

Figure 3-21 Connections between the FPGA, 2x5 header, and the A/D converter

Table 3-12 Pin Assignment of ADC

Signal Name	FPGA Pin No.	Description	I/O Standard
ADC_CONVST	PIN_U9	Conversion Start	3.3V
ADC_SCK	PIN_V10	Serial Data Clock	3.3V
ADC_SDI	PIN_AC4	Serial Data Input (FPGA to ADC)	3.3V
ADC_SDO	PIN_AD4	Serial Data Out (ADC to FPGA)	3.3V

3.7 Peripherals Connected to Hard Processor System (HPS)

This section introduces the interfaces connected to the HPS section of the Cyclone V SoC FPGA. Users can access these interfaces via the HPS processor.

3.7.1 User Push-buttons and LEDs

Similar to the FPGA, the HPS also has its set of switches, buttons, LEDs, and other interfaces connected exclusively. Users can control these interfaces to monitor the status of HPS.

Table 3-13 gives the pin assignment of all the LEDs, switches, and push-buttons.

Table 3-13 Pin Assignment of LEDs, Switches and Push-buttons

<i>Signal Name</i>	<i>FPGA Pin No.</i>	<i>HPS GPIO</i>	<i>Register/bit</i>	<i>Function</i>
HPS_KEY	PIN_J18	GPIO54	GPIO1[25]	I/O
HPS_LED	PIN_A20	GPIO53	GPIO1[24]	I/O

3.7.2 Gigabit Ethernet

The board supports Gigabit Ethernet transfer by an external Micrel KSZ9031RN PHY chip and HPS Ethernet MAC function. The KSZ9031RN chip with integrated 10/100/1000 Mbps Gigabit Ethernet transceiver also supports RGMII MAC interface. **Figure 3-22** shows the connections between the HPS, Gigabit Ethernet PHY, and RJ-45 connector.

The pin assignment associated to Gigabit Ethernet interface is listed in **Table 3-14**. More information about the KSZ9031RN PHY chip and its datasheet, as well as the application notes, which are available on the manufacturer's website.

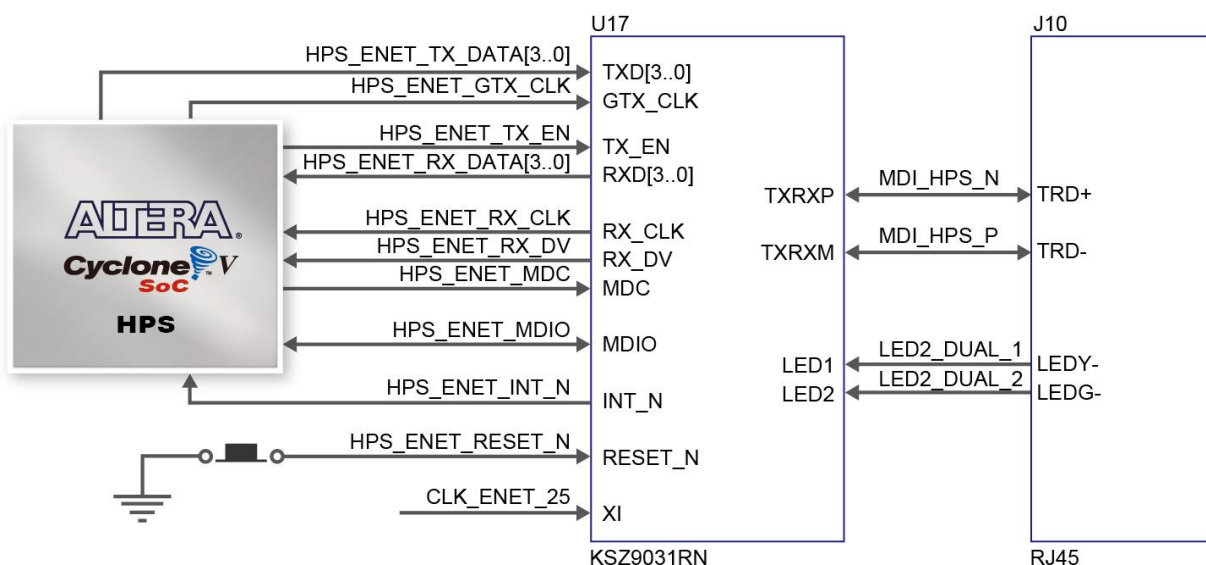

Figure 3-22 Connections between the HPS and Gigabit Ethernet

Table 3-14 Pin Assignment of Gigabit Ethernet PHY

Signal Name	FPGA Pin No.	Description	I/O Standard
HPS_ENET_TX_EN	PIN_A12	GMII and MII transmit enable	3.3V
HPS_ENET_TX_DATA[0]	PIN_A16	MII transmit data[0]	3.3V
HPS_ENET_TX_DATA[1]	PIN_J14	MII transmit data[1]	3.3V
HPS_ENET_TX_DATA[2]	PIN_A15	MII transmit data[2]	3.3V
HPS_ENET_TX_DATA[3]	PIN_D17	MII transmit data[3]	3.3V
HPS_ENET_RX_DV	PIN_J13	GMII and MII receive data valid	3.3V
HPS_ENET_RX_DATA[0]	PIN_A14	GMII and MII receive data[0]	3.3V
HPS_ENET_RX_DATA[1]	PIN_A11	GMII and MII receive data[1]	3.3V
HPS_ENET_RX_DATA[2]	PIN_C15	GMII and MII receive data[2]	3.3V
HPS_ENET_RX_DATA[3]	PIN_A9	GMII and MII receive data[3]	3.3V
HPS_ENET_RX_CLK	PIN_J12	GMII and MII receive clock	3.3V
HPS_ENET_RESET_N	PIN_B14	Hardware Reset Signal	3.3V
HPS_ENET_MDIO	PIN_E16	Management Data	3.3V
HPS_ENET_MDC	PIN_A13	Management Data Clock Reference	3.3V
HPS_ENET_INT_N	PIN_B14	Interrupt Open Drain Output	3.3V
HPS_ENET_GTX_CLK	PIN_J15	GMII Transmit Clock	3.3V

There are two LEDs, green LED (LEDG) and yellow LED (LEDY), which represent the status of Ethernet PHY (KSZ9031RN). The LED control signals are connected to the LEDs on the RJ45 connector. The state and definition of LEDG and LEDY are listed in [Table 3-15](#). For instance, the connection from board to Gigabit Ethernet is established once the LEDG lights on.

Table 3-15 State and Definition of LED Mode Pins

LED (State)		LED (Definition)		Link /Activity
LEDG	LEDY	LEDG	LEDY	
H	H	OFF	OFF	Link off
L	H	ON	OFF	1000 Link / No Activity
Toggle	H	Blinking	OFF	1000 Link / Activity (RX, TX)
H	L	OFF	ON	100 Link / No Activity
H	Toggle	OFF	Blinking	100 Link / Activity (RX, TX)
L	L	ON	ON	10 Link/ No Activity
Toggle	Toggle	Blinking	Blinking	10 Link / Activity (RX, TX)

3.7.3 UART

The board has one UART interface connected for communication with the HPS. This interface doesn't support HW flow control signals. The physical interface is implemented by UART-USB onboard bridge from a FT232R chip to the host with an USB Mini-B connector. More information about the chip is available on the manufacturer's website, or in the directory \Datasheets\UART_TO_USB of DE0-Nano-SoC system CD. **Figure 3-23** shows the connections between the HPS, FT232R chip, and the USB Mini-B connector. **Table 3-16** lists the pin assignment of UART interface connected to the HPS.

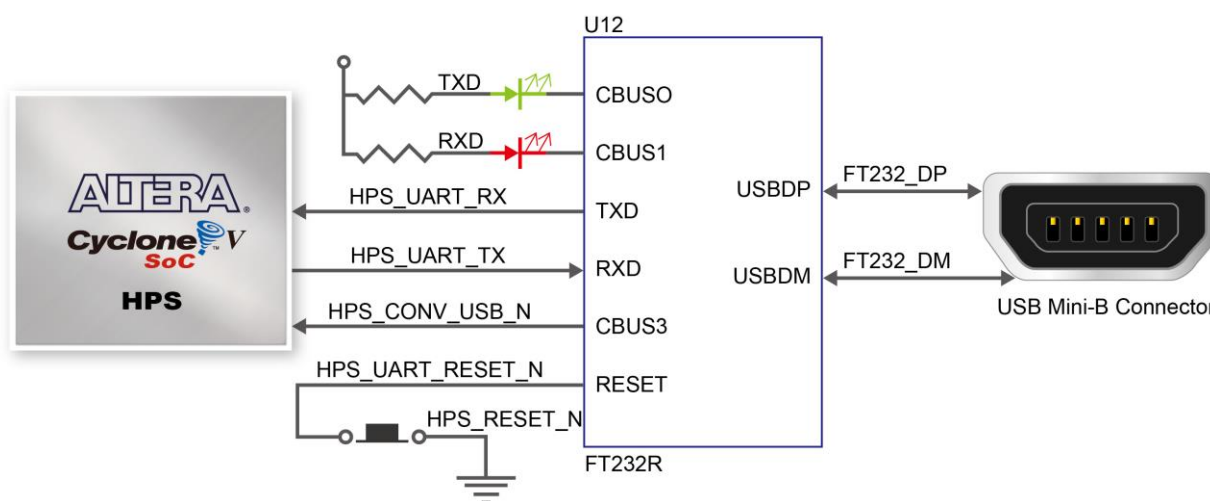

Figure 3-23 Connections between the HPS and FT232R Chip

Table 3-16 Pin Assignment of UART Interface

<i>Signal Name</i>	<i>FPGA Pin No.</i>	<i>Description</i>	<i>I/O Standard</i>
HPS_UART_RX	PIN_A22	HPS UART Receiver	3.3V
HPS_UART_TX	PIN_B21	HPS UART Transmitter	3.3V
HPS_CONV_USB_N	PIN_C6	Reserve	3.3V

3.7.4 DDR3 Memory

The DDR3 devices connected to the HPS are the exact same model as the ones connected to the FPGA. The capacity is 1GB and the data bandwidth is in 32-bit, comprised of two x16 devices with a single address/command bus. The signals are connected to the dedicated Hard Memory Controller for HPS I/O banks and the target speed is 400 MHz. **Table 3-17** lists the pin assignment of DDR3 and its description with I/O standard.

Table 3-17 Pin Assignment of DDR3 Memory

<i>Signal Name</i>	<i>FPGA Pin No.</i>	<i>Description</i>	<i>I/O Standard</i>
HPS_DDR3_A[0]	PIN_C28	HPS DDR3 Address[0]	SSTL-15 Class I
HPS_DDR3_A[1]	PIN_B28	HPS DDR3 Address[1]	SSTL-15 Class I
HPS_DDR3_A[2]	PIN_E26	HPS DDR3 Address[2]	SSTL-15 Class I
HPS_DDR3_A[3]	PIN_D26	HPS DDR3 Address[3]	SSTL-15 Class I
HPS_DDR3_A[4]	PIN_J21	HPS DDR3 Address[4]	SSTL-15 Class I
HPS_DDR3_A[5]	PIN_J20	HPS DDR3 Address[5]	SSTL-15 Class I
HPS_DDR3_A[6]	PIN_C26	HPS DDR3 Address[6]	SSTL-15 Class I
HPS_DDR3_A[7]	PIN_B26	HPS DDR3 Address[7]	SSTL-15 Class I
HPS_DDR3_A[8]	PIN_F26	HPS DDR3 Address[8]	SSTL-15 Class I
HPS_DDR3_A[9]	PIN_F25	HPS DDR3 Address[9]	SSTL-15 Class I
HPS_DDR3_A[10]	PIN_A24	HPS DDR3 Address[10]	SSTL-15 Class I
HPS_DDR3_A[11]	PIN_B24	HPS DDR3 Address[11]	SSTL-15 Class I
HPS_DDR3_A[12]	PIN_D24	HPS DDR3 Address[12]	SSTL-15 Class I
HPS_DDR3_A[13]	PIN_C24	HPS DDR3 Address[13]	SSTL-15 Class I
HPS_DDR3_A[14]	PIN_G23	HPS DDR3 Address[14]	SSTL-15 Class I
HPS_DDR3_BA[0]	PIN_A27	HPS DDR3 Bank Address[0]	SSTL-15 Class I
HPS_DDR3_BA[1]	PIN_H25	HPS DDR3 Bank Address[1]	SSTL-15 Class I
HPS_DDR3_BA[2]	PIN_G25	HPS DDR3 Bank Address[2]	SSTL-15 Class I
HPS_DDR3_CAS_n	PIN_A26	DDR3 Column Address Strobe	SSTL-15 Class I
HPS_DDR3_CKE	PIN_L28	HPS DDR3 Clock Enable	SSTL-15 Class I
HPS_DDR3_CK_n	PIN_N20	HPS DDR3 Clock	Differential 1.5-V SSTL Class I
HPS_DDR3_CK_p	PIN_N21	HPS DDR3 Clock p	Differential 1.5-V SSTL Class I
HPS_DDR3_CS_n	PIN_L21	HPS DDR3 Chip Select	SSTL-15 Class I
HPS_DDR3_DM[0]	PIN_G28	HPS DDR3 Data Mask[0]	SSTL-15 Class I
HPS_DDR3_DM[1]	PIN_P28	HPS DDR3 Data Mask[1]	SSTL-15 Class I
HPS_DDR3_DM[2]	PIN_W28	HPS DDR3 Data Mask[2]	SSTL-15 Class I

HPS_DDR3_DM[3]	PIN_AB28	HPS DDR3 Data Mask[3]	SSTL-15 Class I
HPS_DDR3_DQ[0]	PIN_J25	HPS DDR3 Data[0]	SSTL-15 Class I
HPS_DDR3_DQ[1]	PIN_J24	HPS DDR3 Data[1]	SSTL-15 Class I
HPS_DDR3_DQ[2]	PIN_E28	HPS DDR3 Data[2]	SSTL-15 Class I
HPS_DDR3_DQ[3]	PIN_D27	HPS DDR3 Data[3]	SSTL-15 Class I
HPS_DDR3_DQ[4]	PIN_J26	HPS DDR3 Data[4]	SSTL-15 Class I
HPS_DDR3_DQ[5]	PIN_K26	HPS DDR3 Data[5]	SSTL-15 Class I
HPS_DDR3_DQ[6]	PIN_G27	HPS DDR3 Data[6]	SSTL-15 Class I
HPS_DDR3_DQ[7]	PIN_F28	HPS DDR3 Data[7]	SSTL-15 Class I
HPS_DDR3_DQ[8]	PIN_K25	HPS DDR3 Data[8]	SSTL-15 Class I
HPS_DDR3_DQ[9]	PIN_L25	HPS DDR3 Data[9]	SSTL-15 Class I
HPS_DDR3_DQ[10]	PIN_J27	HPS DDR3 Data[10]	SSTL-15 Class I
HPS_DDR3_DQ[11]	PIN_J28	HPS DDR3 Data[11]	SSTL-15 Class I
HPS_DDR3_DQ[12]	PIN_M27	HPS DDR3 Data[12]	SSTL-15 Class I
HPS_DDR3_DQ[13]	PIN_M26	HPS DDR3 Data[13]	SSTL-15 Class I
HPS_DDR3_DQ[14]	PIN_M28	HPS DDR3 Data[14]	SSTL-15 Class I
HPS_DDR3_DQ[15]	PIN_N28	HPS DDR3 Data[15]	SSTL-15 Class I
HPS_DDR3_DQ[16]	PIN_N24	HPS DDR3 Data[16]	SSTL-15 Class I
HPS_DDR3_DQ[17]	PIN_N25	HPS DDR3 Data[17]	SSTL-15 Class I
HPS_DDR3_DQ[18]	PIN_T28	HPS DDR3 Data[18]	SSTL-15 Class I
HPS_DDR3_DQ[19]	PIN_U28	HPS DDR3 Data[19]	SSTL-15 Class I
HPS_DDR3_DQ[20]	PIN_N26	HPS DDR3 Data[20]	SSTL-15 Class I
HPS_DDR3_DQ[21]	PIN_N27	HPS DDR3 Data[21]	SSTL-15 Class I
HPS_DDR3_DQ[22]	PIN_R27	HPS DDR3 Data[22]	SSTL-15 Class I
HPS_DDR3_DQ[23]	PIN_V27	HPS DDR3 Data[23]	SSTL-15 Class I
HPS_DDR3_DQ[24]	PIN_R26	HPS DDR3 Data[24]	SSTL-15 Class I
HPS_DDR3_DQ[25]	PIN_R25	HPS DDR3 Data[25]	SSTL-15 Class I
HPS_DDR3_DQ[26]	PIN_AA28	HPS DDR3 Data[26]	SSTL-15 Class I
HPS_DDR3_DQ[27]	PIN_W26	HPS DDR3 Data[27]	SSTL-15 Class I
HPS_DDR3_DQ[28]	PIN_R24	HPS DDR3 Data[28]	SSTL-15 Class I
HPS_DDR3_DQ[29]	PIN_T24	HPS DDR3 Data[29]	SSTL-15 Class I
HPS_DDR3_DQ[30]	PIN_Y27	HPS DDR3 Data[30]	SSTL-15 Class I
HPS_DDR3_DQ[31]	PIN_AA27	HPS DDR3 Data[31]	SSTL-15 Class I
HPS_DDR3_DQS_n[0]	PIN_R16	HPS DDR3 Data Strobe n[0]	Differential 1.5-V SSTL Class I
HPS_DDR3_DQS_n[1]	PIN_R18	HPS DDR3 Data Strobe n[1]	Differential 1.5-V SSTL Class I
HPS_DDR3_DQS_n[2]	PIN_T18	HPS DDR3 Data Strobe n[2]	Differential 1.5-V SSTL Class I
HPS_DDR3_DQS_n[3]	PIN_T20	HPS DDR3 Data Strobe n[3]	Differential 1.5-V SSTL Class I
HPS_DDR3_DQS_p[0]	PIN_R17	HPS DDR3 Data Strobe p[0]	Differential 1.5-V SSTL Class I
HPS_DDR3_DQS_p[1]	PIN_R19	HPS DDR3 Data Strobe p[1]	Differential 1.5-V SSTL Class I
HPS_DDR3_DQS_p[2]	PIN_T19	HPS DDR3 Data Strobe p[2]	Differential 1.5-V SSTL Class I
HPS_DDR3_DQS_p[3]	PIN_U19	HPS DDR3 Data Strobe p[3]	Differential 1.5-V SSTL Class I
HPS_DDR3_ODT	PIN_D28	HPS DDR3 On-die Termination	SSTL-15 Class I
HPS_DDR3_RAS_n	PIN_A25	DDR3 Row Address Strobe	SSTL-15 Class I
HPS_DDR3_RESET_n	PIN_V28	HPS DDR3 Reset	SSTL-15 Class I

HPS_DDR3_WE_n	PIN_E25	HPS DDR3 Write Enable	SSTL-15 Class I
HPS_DDR3_RZQ	PIN_D25	External reference ball for output drive calibration	1.5 V

3.7.5 Micro SD Card Socket

The board supports Micro SD card interface with x4 data lines. It serves not only an external storage for the HPS, but also an alternative boot option for DE0-Nano0-SoC board. **Figure 3-24** shows signals connected between the HPS and Micro SD card socket.

Table 3-18 lists the pin assignment of Micro SD card socket to the HPS.

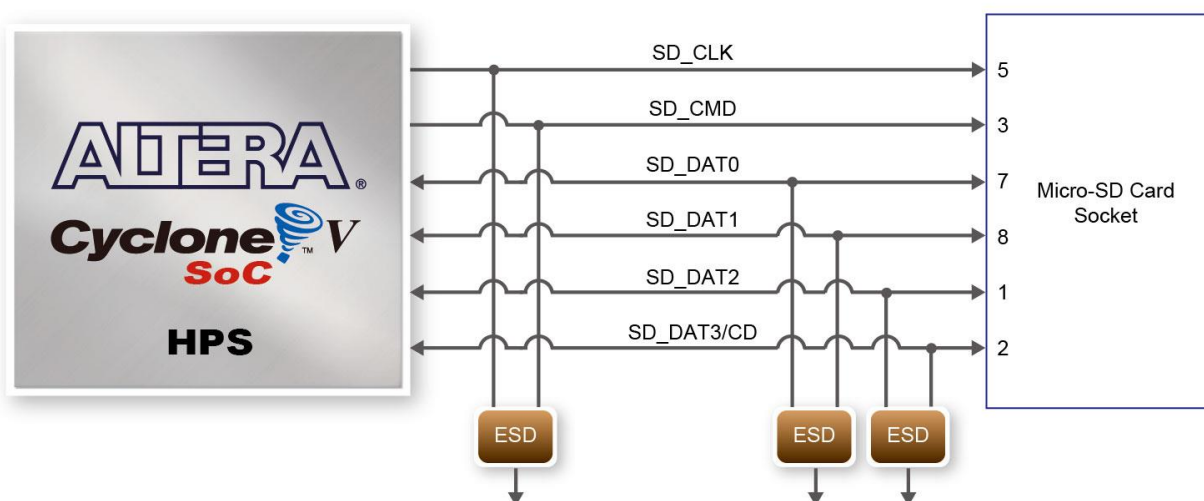

Figure 3-24 Connections between the FPGA and SD card socket

Table 3-18 Pin Assignment of Micro SD Card Socket

Signal Name	FPGA Pin No.	Description	I/O Standard
HPS_SD_CLK	PIN_B8	HPS SD Clock	3.3V
HPS_SD_CMD	PIN_D14	HPS SD Command Line	3.3V
HPS_SD_DATA[0]	PIN_C13	HPS SD Data[0]	3.3V
HPS_SD_DATA[1]	PIN_B6	HPS SD Data[1]	3.3V
HPS_SD_DATA[2]	PIN_B11	HPS SD Data[2]	3.3V
HPS_SD_DATA[3]	PIN_B9	HPS SD Data[3]	3.3V

3.7.6 USB 2.0 OTG PHY

The board provides USB interfaces using the SMSC USB3300 controller. A SMSC USB3300 device in a 32-pin QFN package device is used to interface to a single Type AB Micro-USB connector. This device supports UTMI+ Low Pin Interface (ULPI) to communicate to USB 2.0 controller in HPS. As defined by OTG mode, the PHY can operate in Host or Device modes. When operating in Host mode, the interface will supply the power to the device through the Micro-USB interface. **Figure 3-25** shows the connections of USB PTG PHY to the HPS. **Table 3-19** lists the pin assignment of USB OTG PHY to the HPS.

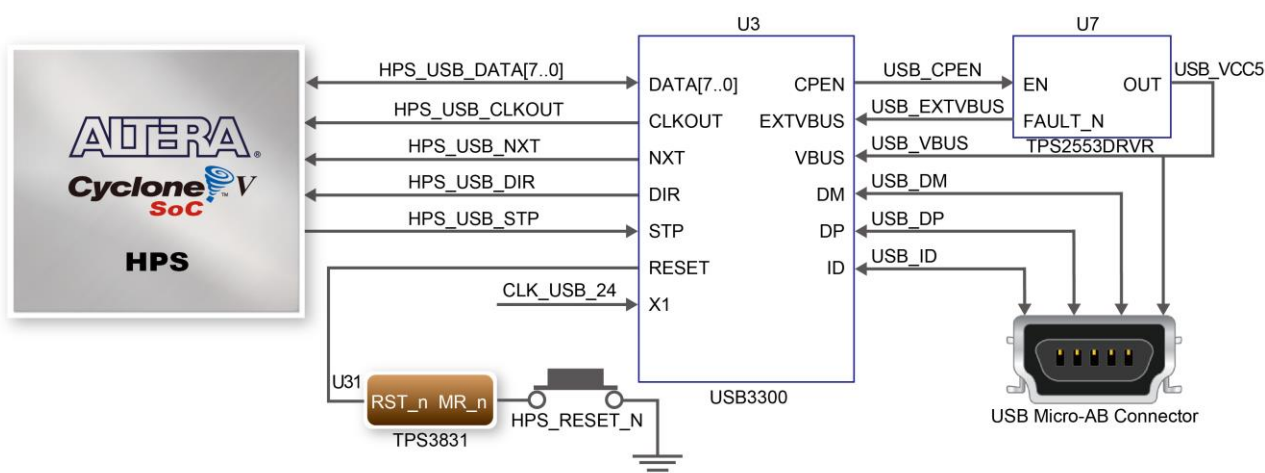

Figure 3-25 Connections between the HPS and USB OTG PHY

Table 3-19 Pin Assignment of USB OTG PHY

Signal Name	FPGA Pin No.	Description	I/O Standard
HPS_USB_CLKOUT	PIN_G4	60MHz Reference Clock Output	3.3V
HPS_USB_DATA[0]	PIN_C10	HPS USB_DATA[0]	3.3V
HPS_USB_DATA[1]	PIN_F5	HPS USB_DATA[1]	3.3V
HPS_USB_DATA[2]	PIN_C9	HPS USB_DATA[2]	3.3V
HPS_USB_DATA[3]	PIN_C4	HPS USB_DATA[3]	3.3V
HPS_USB_DATA[4]	PIN_C8	HPS USB_DATA[4]	3.3V
HPS_USB_DATA[5]	PIN_D4	HPS USB_DATA[5]	3.3V
HPS_USB_DATA[6]	PIN_C7	HPS USB_DATA[6]	3.3V
HPS_USB_DATA[7]	PIN_F4	HPS USB_DATA[7]	3.3V
HPS_USB_DIR	PIN_E5	Direction of the Data Bus	3.3V
HPS_USB_NXT	PIN_D5	Throttle the Data	3.3V
HPS_USB_RESET	PIN_H12	HPS USB PHY Reset	3.3V
HPS_USB_STP	PIN_C5	Stop Data Stream on the Bus	3.3V

3.7.7 G-sensor

The board comes with a digital accelerometer sensor module (ADXL345), commonly known as G-sensor. This G-sensor is a small, thin, ultralow power assumption 3-axis accelerometer with high-resolution measurement. Digitalized output is formatted as 16-bit in two's complement and can be accessed through I2C interface. The I2C address of G-sensor is 0xA6/0xA7. More information about this chip can be found in its datasheet, which is available on manufacturer's website or in the directory \Datasheet\G-Sensor folder of DE0-Nano-SoC system CD. **Figure 3-26** shows the connections between the HPS and G-sensor. **Table 3-20** lists the pin assignment of G-sensor to the HPS.

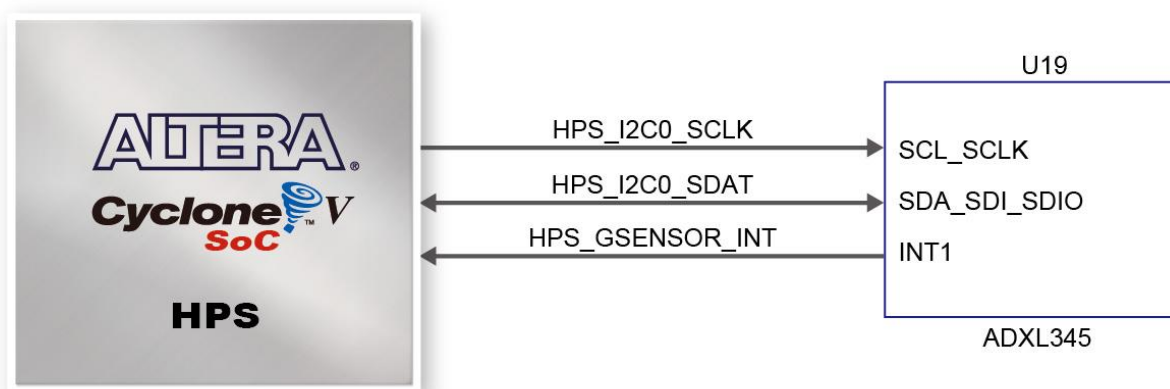

Figure 3-26 Connections between Cyclone V SoC FPGA and G-Sensor

Table 3-20 Pin Assignment of G-sensor

Signal Name	FPGA Pin No.	Description	I/O Standard
HPS_GSENSOR_INT	PIN_A17	HPS GSENSOR Interrupt Output	3.3V
HPS_I2C0_SCLK	PIN_C18	HPS I2C0 Clock	3.3V
HPS_I2C0_SDAT	PIN_A19	HPS I2C0 Data	3.3V

3.7.8 LTC Connector

The board has a 14-pin header, which is originally used to communicate with various daughter cards from Linear Technology. It is connected to the SPI Master and I2C ports of HPS. The communication with these two protocols is bi-directional. The 14-pin header can also be used for GPIO, SPI, or I2C based communication with the HPS. Connections between the HPS and LTC

connector are shown in **Figure 3-27**, and the pin assignment of LTC connector is listed in **Table 3-21**.

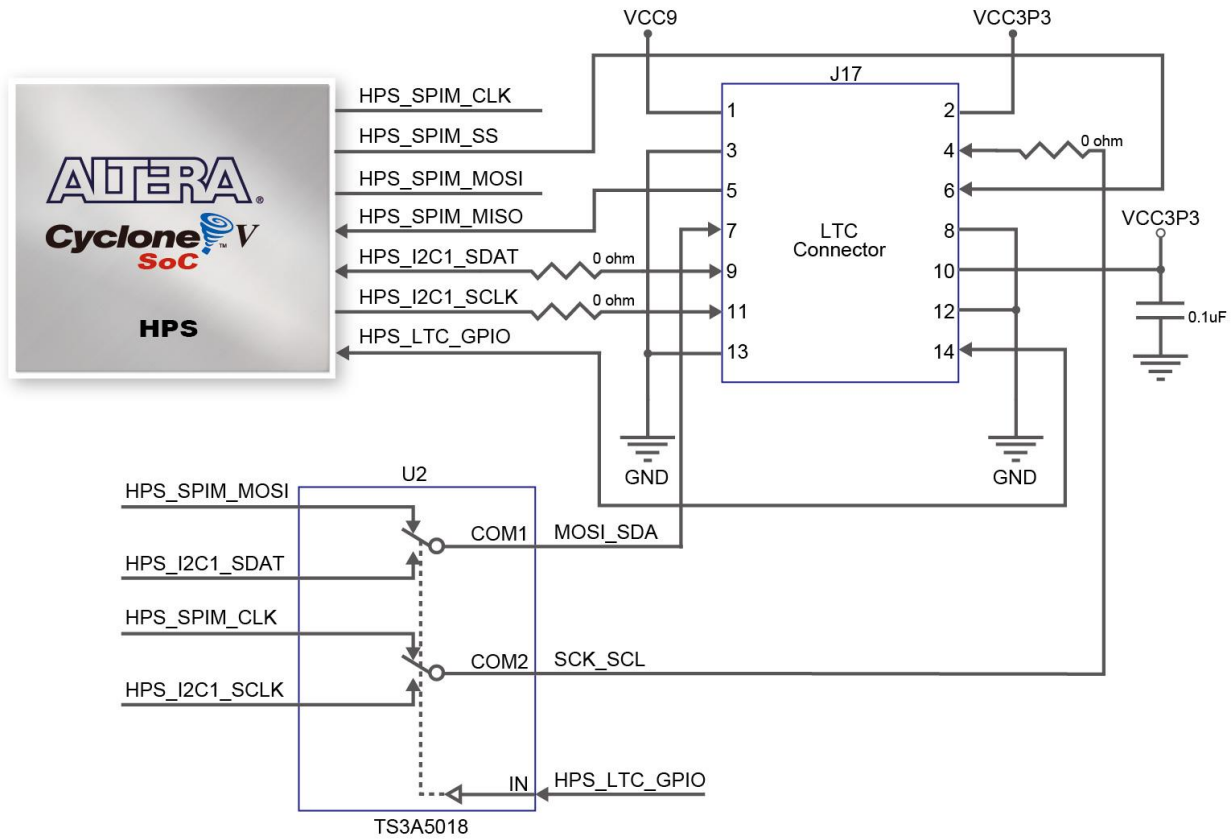

Figure 3-27 Connections between the HPS and LTC connector

Table 3-21 Pin Assignment of LTC Connector

<i>Signal Name</i>	<i>FPGA Pin No.</i>	<i>Description</i>	<i>I/O Standard</i>
HPS_LTC_GPIO	PIN_H13	HPS LTC GPIO	3.3V
HPS_I2C1_SCLK	PIN_B21	HPS I2C1 Clock	3.3V
HPS_I2C1_SDAT	PIN_A21	HPS I2C1 Data	3.3V
HPS_SPIM_CLK	PIN_C19	SPI Clock	3.3V
HPS_SPIM_MISO	PIN_B19	SPI Master Input/Slave Output	3.3V
HPS_SPIM_MOSI	PIN_B16	SPI Master Output /Slave Input	3.3V
HPS_SPIM_SS	PIN_C16	SPI Slave Select	3.3V

Chapter 4

DE0-Nano-SoC System Builder

This chapter describes how users can create a custom design project with the tool named DE0-Nano-SoC System Builder.

4.1 Introduction

The DE0-Nano-SoC System Builder is a Windows-based utility. It is designed to help users create a Quartus II project for DE0-Nano-SoC within minutes. The generated Quartus II project files include:

- Quartus II project file (.qpf)
- Quartus II setting file (.qsf)
- Top-level design file (.v)
- Synopsis design constraints file (.sdc)
- Pin assignment document (.htm)

The above files generated by the DE0-Nano-SoC System Builder can also prevent occurrence of situations that are prone to compilation error when users manually edit the top-level design file or place pin assignment. The common mistakes that users encounter are:

- Board is damaged due to incorrect bank voltage setting or pin assignment.
- Board is malfunctioned because of wrong device chosen, declaration of pin location or direction is incorrect or forgotten.
- Performance degradation due to improper pin assignment.

4.2 Design Flow

This section provides an introduction to the design flow of building a Quartus II project for

DE0-Nano-SoC under the DE0-Nano-SoC System Builder. The design flow is illustrated in **Figure 4-1**.

The DE0-Nano-SoC System Builder will generate two major files, a top-level design file (.v) and a Quartus II setting file (.qsf) after users launch the DE0-Nano-SoC System Builder and create a new project according to their design requirements.

The top-level design file contains a top-level Verilog HDL wrapper for users to add their own design/logic. The Quartus II setting file contains information such as FPGA device type, top-level pin assignment, and the I/O standard for each user-defined I/O pin.

Finally, the Quartus II programmer is used to download .sof file to the development board via JTAG interface.

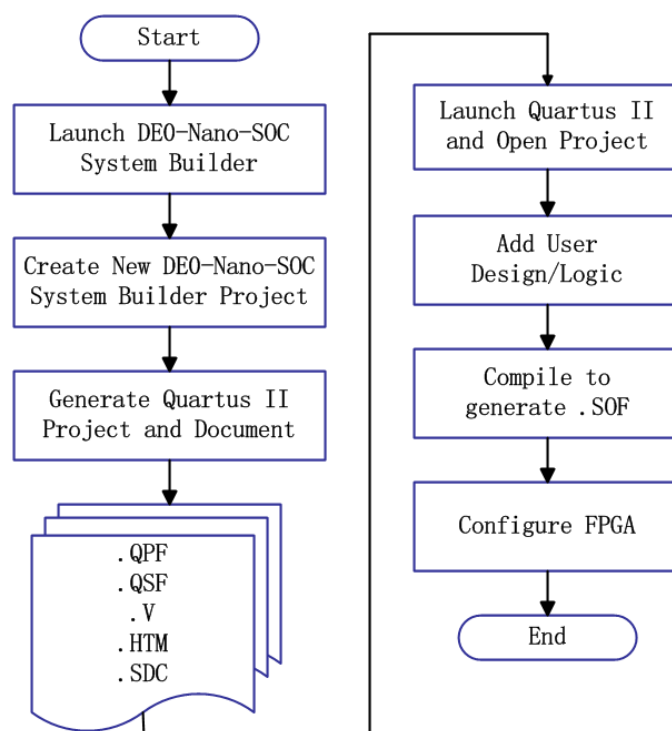

Figure 4-1 Design flow of building a project from the beginning to the end

4.3 Using DE0-Nano-SoC System Builder

This section provides the procedures in details on how to use the DE0-Nano-SoC System Builder.

■ Install and Launch the DE0-Nano-SoC System Builder

The DE0-Nano-SoC System Builder is located in the directory: “Tools\SystemBuilder” of the DE0-Nano-SoC System CD. Users can copy the entire folder to a host computer without installing the utility. A window will pop up, as shown in **Figure 4-2**, after executing the DE0-Nano-SoC SystemBuilder.exe on the host computer.

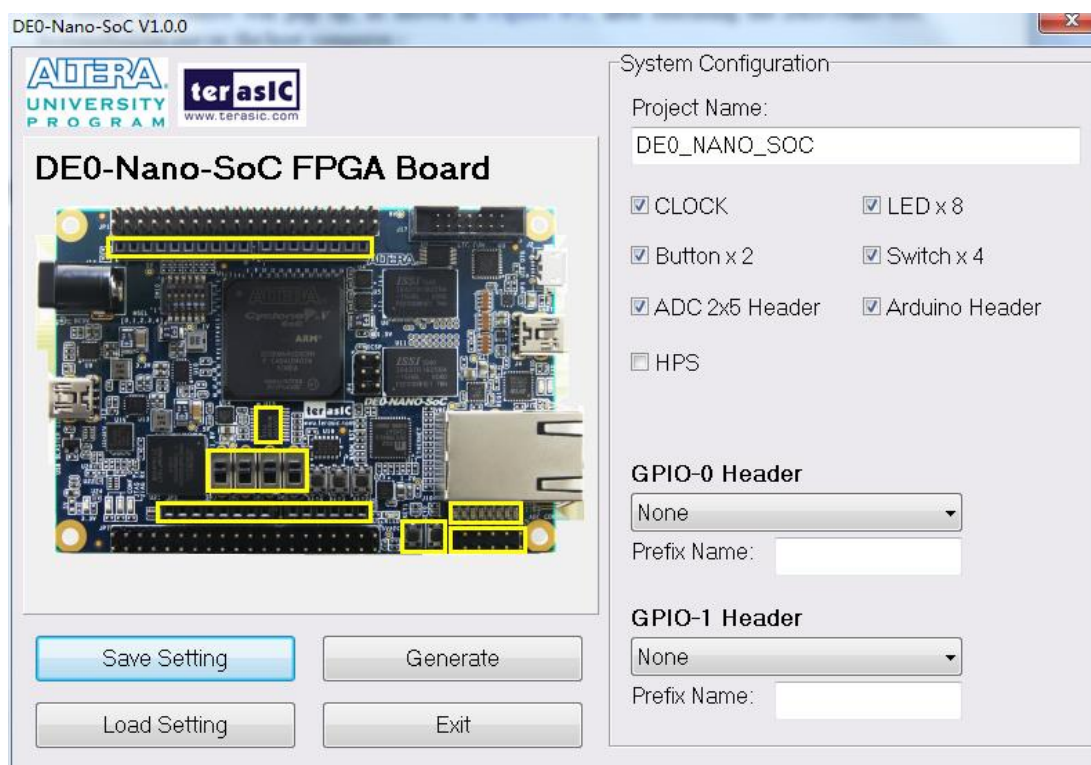

Figure 4-2 The GUI of DE0-Nano-SoC System Builder

■ Enter Project Name

Enter the project name in the circled area, as shown in **Figure 4-3**.

The project name typed in will be assigned automatically as the name of your top-level design entity.

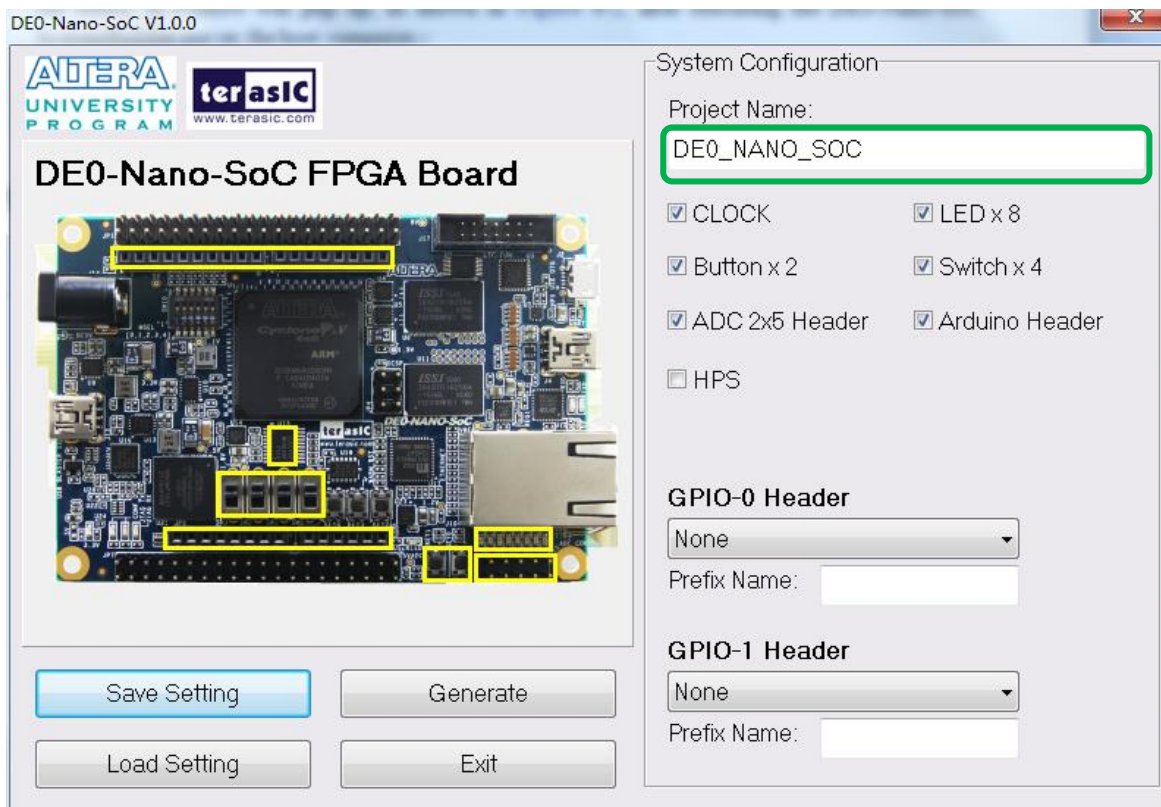

Figure 4-3 Enter the project name

■ System Configuration

Users are given the flexibility in the System Configuration to include their choice of components in the project, as shown in **Figure 4-4**. Each component onboard is listed and users can enable or disable one or more components at will. If a component is enabled, the DE0-Nano-SoC System Builder will automatically generate its associated pin assignment, including the pin name, pin location, pin direction, and I/O standard.

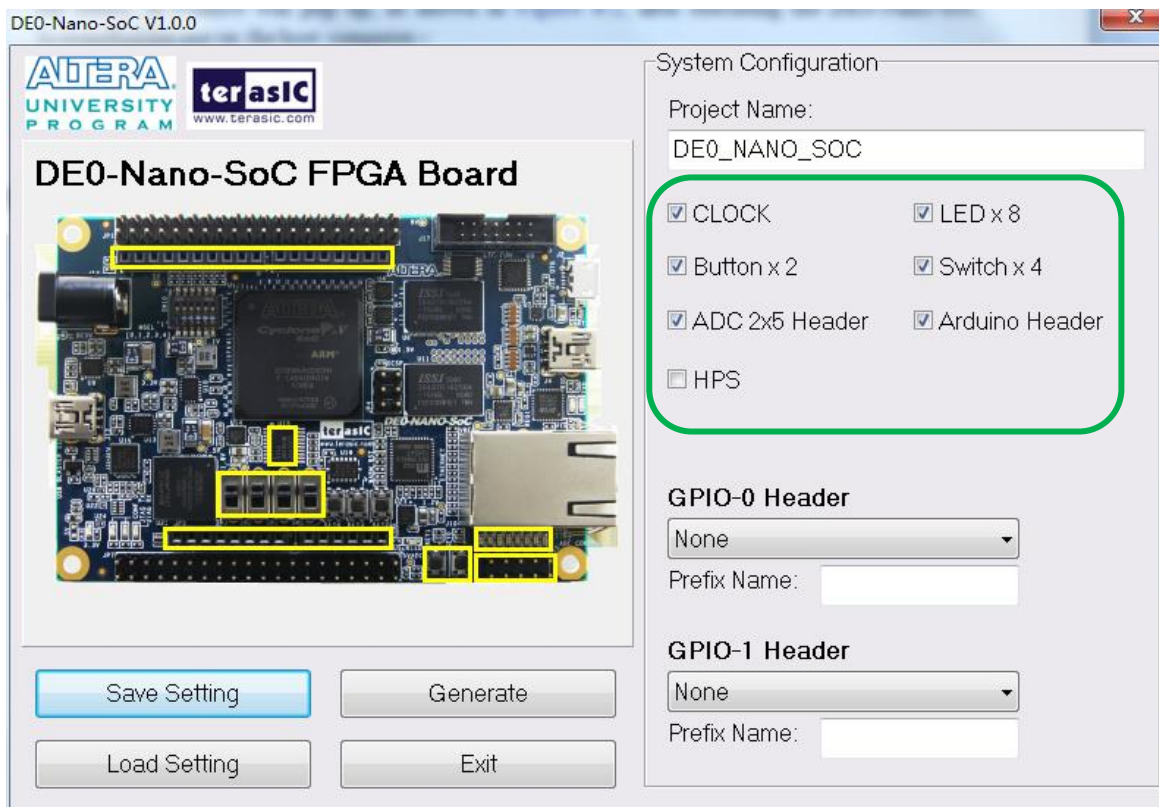

Figure 4-4 System configuration group

■ GPIO Expansion

If users connect any Terasic GPIO-based daughter card to the GPIO connector(s) on DE0-Nano-SoC, the DE0-Nano-SoC System Builder can generate a project that include the corresponding module, as shown in **Figure 4-5**. It will also generate the associated pin assignment automatically, including pin name, pin location, pin direction, and I/O standard.

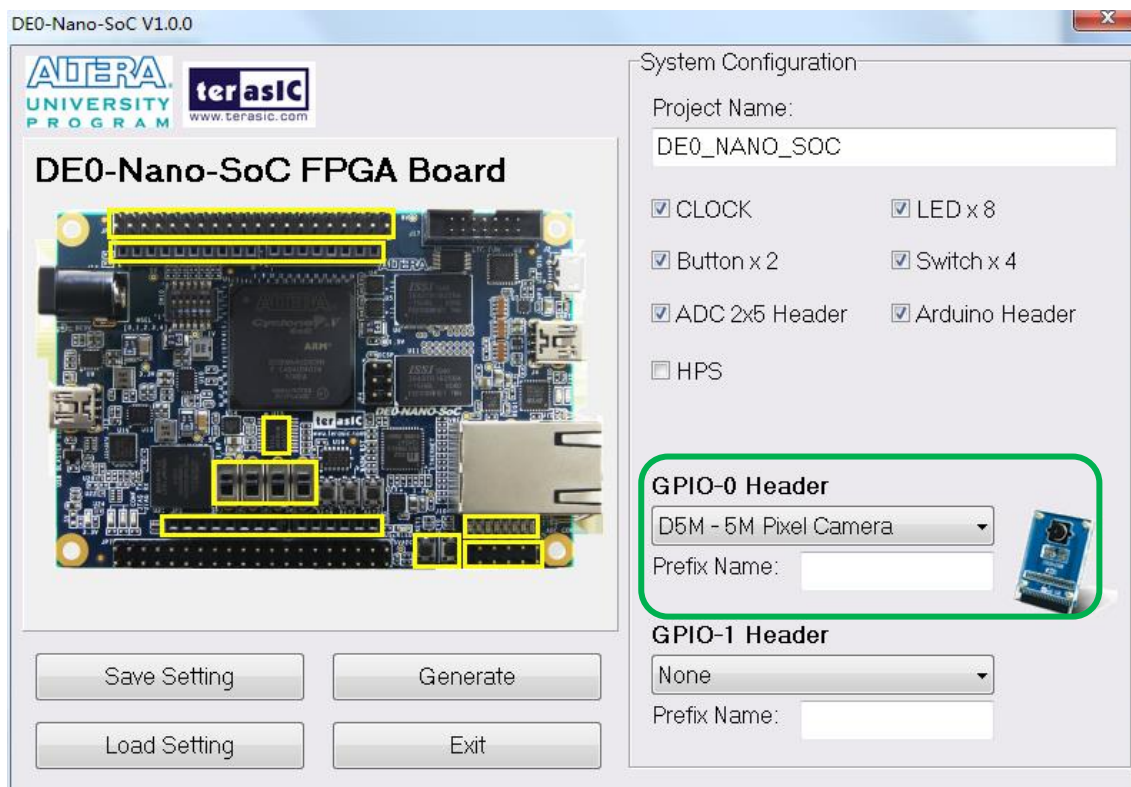

Figure 4-5 GPIO expansion group

The “Prefix Name” is an optional feature that denote the pin name of the daughter card assigned in your design. Users may leave this field blank.

■ Project Setting Management

The DE0-Nano-SoC System Builder also provides the option to load a setting or save users’ current board configuration in .cfg file, as shown in **Figure 4-6**.

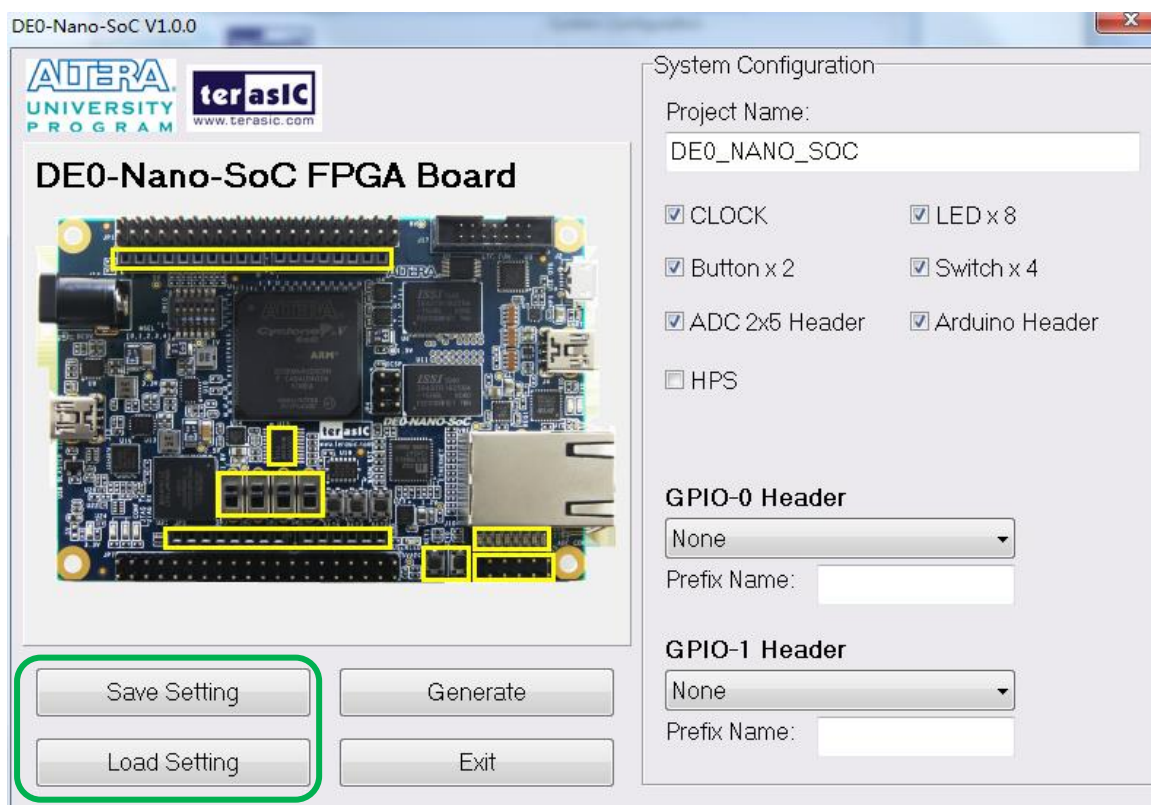

Figure 4-6 Project Settings

■ **Project Generation**

When users press the *Generate* button, the DE0-Nano-SoC System Builder will generate the corresponding Quartus II files and documents, as listed in **Table 4-1**:

Table 4-1 Files generated by the DE0-Nano-SoC System Builder

No.	Filename	Description
1	<Project name>.v	Top level Verilog HDL file for Quartus II
2	<Project name>.qpf	Quartus II Project File
3	<Project name>.qsf	Quartus II Setting File
4	<Project name>.sdc	Synopsis Design Constraints file for Quartus II
5	<Project name>.htm	Pin Assignment Document

Users can add custom logic into the project in Quartus II and compile the project to generate the SRAM Object File (.sof).

Chapter 5

Examples For FPGA

This chapter provides examples of advanced designs implemented by RTL or Qsys on the DE0-Nano-SoC board. These reference designs cover the features of peripherals connected to the FPGA, such as A/D Converter. All the associated files can be found in the directory \Demonstrations\FPGA of DE0-Nano-SoC System CD.

■ Installation of Demonstrations

Install the demonstrations on your computer:

Copy the folder Demonstrations to a local directory of your choice. It is important to make sure the path to your local directory contains NO space. Otherwise it will lead to error in Nios II.

Note Quartus II v14.0 or later is required for all DE0-Nano-SoC demonstrations to support Cyclone V SoC device.

5.1 DE0-Nano-SoC Factory Configuration

The DE0-Nano-SoC board has a default configuration bit-stream pre-programmed, which demonstrates some of the basic features on board. The setup required for this demonstration and the location of its files are shown below.

■ Demonstration Setup, File Locations, and Instructions

- Project directory: DE0_NANO_SOC_Default
- Bitstream used: DE0_NANO_SOC_Default.sof or DE0_NANO_SOC_Default.jic
- Power on the DE0-Nano-SoC board with the USB cable connected to the USB-Blaster II port.
If necessary (that is, if the default factory configuration is not currently stored in the EPCS device), download the bit stream to the board via JTAG interface.
- You should now be able to observe the LEDs are blinking.
- For the ease of execution, a demo_batch folder is provided in the project. It is able to not only

load the bit stream into the FPGA in command line, but also program or erase .jic file to the EPCS by executing the test.bat file shown in **Figure 5-1**

If users want to program a new design into the EPCS device, the easiest method is to copy the new .sof file into the demo_batch folder and execute the test.bat. Option “2” will convert the .sof to .jic and option “3” will program .jic file into the EPCS device.

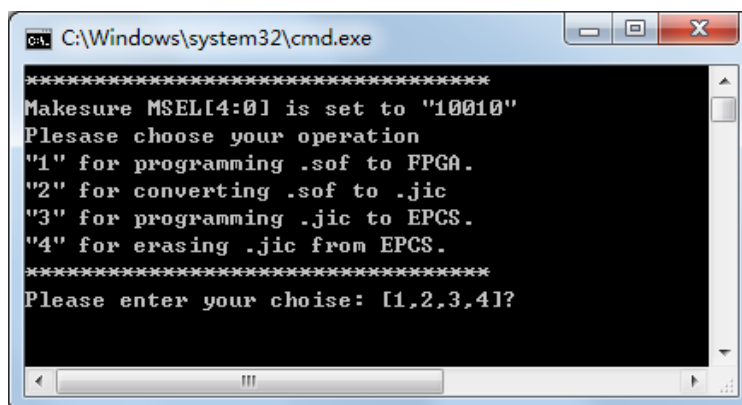

Figure 5-1 Command line of the batch file to program the FPGA and EPCS device

5.2 ADC Reading

This demonstration illustrates steps to evaluate the performance of the 8-channel 12-bit A/D Converter LTC2308. The DC 5.0V on the 2x5 header is used to drive the analog signals by a trimmer potentiometer. The voltage can be adjusted within the range between 0 and 4.096V. The 12-bit voltage measurement is displayed on the NIOS II console. **Figure 5-2** shows the block diagram of this demonstration.

If the input voltage is -2.0V ~ 2.0V, a pre-scale circuit can be used to adjust it to 0 ~ 4V.

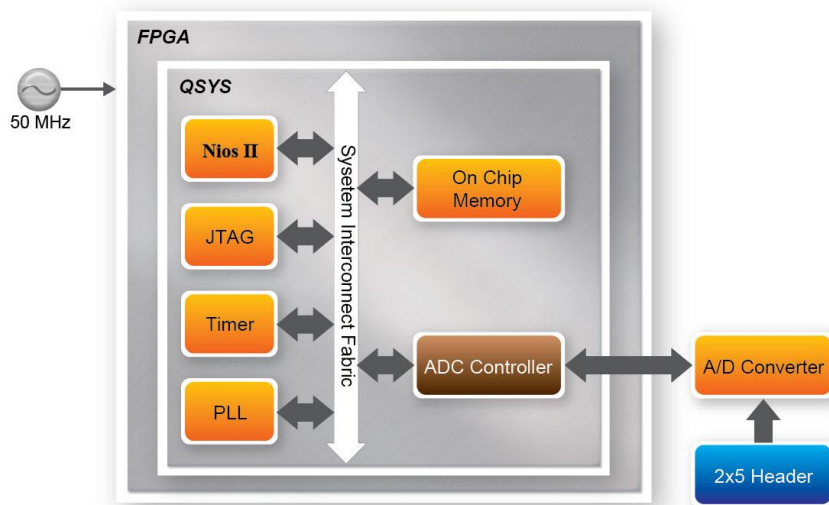

Figure 5-2 Block diagram of ADC reading

Figure 5-3 depicts the pin arrangement of the 2x5 header. This header is the input source of ADC convertor in this demonstration. Users can connect a trimmer to the specified ADC channel (ADC_IN0 ~ ADC_IN7) that provides voltage to the ADC convert. The FPGA will read the associated register in the convertor via serial interface and translates it to voltage value to be displayed on the Nios II console.

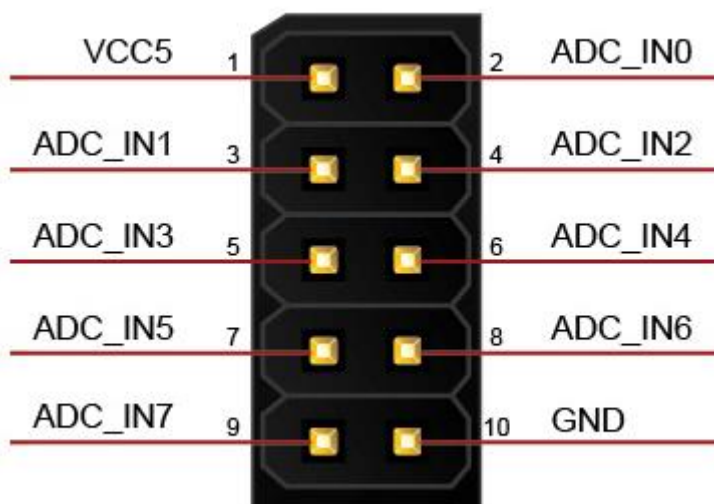

Figure 5-3 Pin distribution of the 2x5 Header for the ADC

■ System Requirements

The following items are required for this demonstration.

- DE0-Nano-SoC board x1
- Trimmer Potentiometer x1
- Wire Strip x3

■ Demonstration File Locations

- Hardware project directory: DE0_NANO_SOC_ADC
- Bitstream used: DE0_NANO_SOC_ADC.sof
- Software project directory: DE0_NANO_SOC_ADC \software
- Demo batch file : DE0_NANO_SOC_ADC \demo_batch\ DE0_NANO_SOC_ADC.bat

■ Demonstration Setup and Instructions

- Connect the trimmer to corresponding ADC channel on the 2x5 header, as shown in **Figure 5-4**, as well as the +5V and GND signals. The setup shown above is connected to ADC channel 0.
- Execute the demo batch file DE0_NANO_SOC_ADC.bat to load the bitstream and software execution file to the FPGA.
- The Nios II console will display the voltage of the specified channel voltage result information

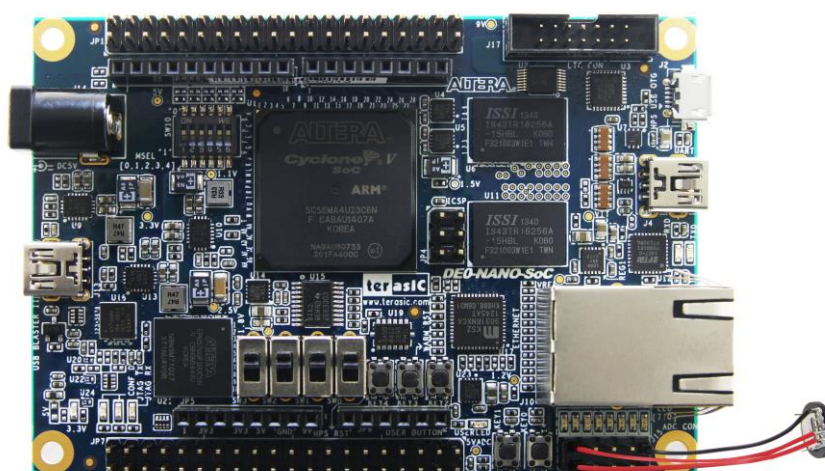

Figure 5-4 Hardware setup for the ADC reading demonstration

Chapter 6

Examples for HPS SoC

This chapter provides several C-code examples based on the Altera SoC Linux built by Yocto project. These examples demonstrate major features of peripherals connected to HPS interface on DE0-Nano-SoC board such as users LED/KEY, I2C interfaced G-sensor. All the associated files can be found in the directory *Demonstrations/SOC* of the DE0-Nano-SoC System CD. Please refer to Chapter 5 "**Running Linux on the DE0-Nano-SoC board**" from the *DE0-Nano-SoC_Getting_Started_Guide.pdf* to run Linux on DE0-Nano-SoC board.

■ Installation of the Demonstrations

To install the demonstrations on the host computer:

Copy the directory *Demonstrations* into a local directory of your choice. **Altera SoC EDS v14.0 is required for users to compile the c-code project.**

6.1 Hello Program

This demonstration shows how to develop first HPS program with Altera SoC EDS tool. Please refer to *My_First_HPS.pdf* from the system CD for more details.

The major procedures to develop and build HPS project are:

- Install Altera SoC EDS on the host PC.
- Create program .c/.h files with a generic text editor
- Create a "Makefile" with a generic text editor
- Build the project under Altera SoC EDS

■ Program File

The main program for the Hello World demonstration is:

```
#include <stdio.h>

int main(int argc, char **argv) {
    printf("Hello World!\r\n");
    return( 0 );
}
```

■ Makefile

A Makefile is required to compile a project. The Makefile used for this demo is:

```
#
TARGET = my_first_hps

#
CROSS_COMPILE = arm-linux-gnueabi-
CFLAGS = -g -Wall -I $(SOCEDS_DEST_ROOT)/ip/altera/hps/altera_hps/hwlib/include
LDFLAGS = -g -Wall
CC = $(CROSS_COMPILE)gcc
ARCH= arm

build: $(TARGET)

$(TARGET): main.o
    $(CC) $(LDFLAGS) $^ -o $@

%.o : %.c
    $(CC) $(CFLAGS) -c $< -o $@

.PHONY: clean
clean:
    rm -f $(TARGET) *.a *.o *~
```

■ Compile

Please launch Altera SoC EDS Command Shell to compile a project by executing

C:\altera\14.0\embedded\Embedded_Command_Shell.bat

The "cd" command can change the current directory to where the Hello World project is located.

The "make" command will build the project. The executable file "**my_first_hps**" will be generated after the compiling process is successful. The "clean all" command removes all temporary files.

■ Demonstration Source Code

- Build tool: Altera SoC EDS v14.0
- Project directory: \Demonstration\SoC\my_first_hps
- Binary file: my_first_hps
- Build command: make ("**make clean**" to remove all temporary files)
- Execute command: ./my_first_hps

■ Demonstration Setup

- Connect a USB cable to the USB-to-UART connector (J4) on the DE0-Nano-SoC board and the host PC.
- Copy the demo file "**my_first_hps**" into a microSD card under the "**/home/root**" folder in Linux.
- Insert the booting microSD card into the DE0-Nano-SoC board.
- Power on the DE0-Nano-SoC board.
- Launch PuTTY and establish connection to the UART port of Putty. Type "**root**" to login Altera Yocto Linux.
- Type "**./my_first_hps**" in the UART terminal of PuTTY to start the program, and the "Hello World!" message will be displayed in the terminal.

```
root@socfpga:~# ./my_first_hps
Hello World!
root@socfpga:~#
```

6.2 Users LED and KEY

This demonstration shows how to control the users LED and KEY by accessing the register of GPIO controller through the memory-mapped device driver. The memory-mapped device driver allows developer to access the system physical memory.

■ Function Block Diagram

Figure 6-1 shows the function block diagram of this demonstration. The users LED and KEY are connected to the **GPIO1** controller in HPS. The behavior of GPIO controller is controlled by the register in GPIO controller. The registers can be accessed by application software through the memory-mapped device driver, which is built into Altera SoC Linux.

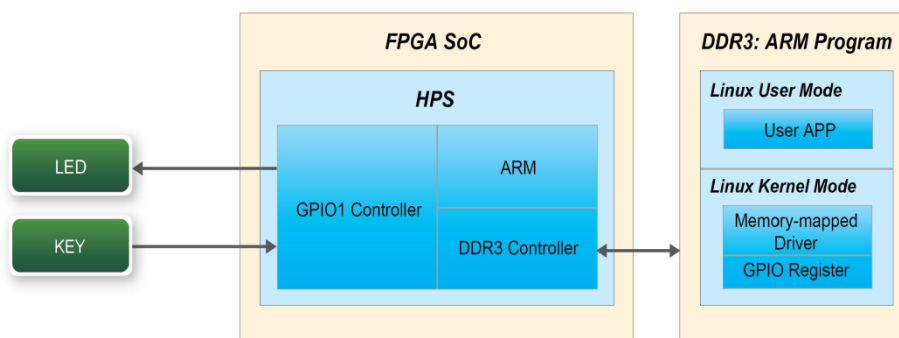

Figure 6-1 Block diagram of GPIO demonstration

■ Block Diagram of GPIO Interface

The HPS provides three general-purpose I/O (GPIO) interface modules. **Figure 6-2** shows the block diagram of GPIO Interface. GPIO[28..0] is controlled by the GPIO0 controller and GPIO[57..29] is controlled by the GPIO1 controller. GPIO[70..58] and input-only GPI[13..0] are controlled by the GPIO2 controller.

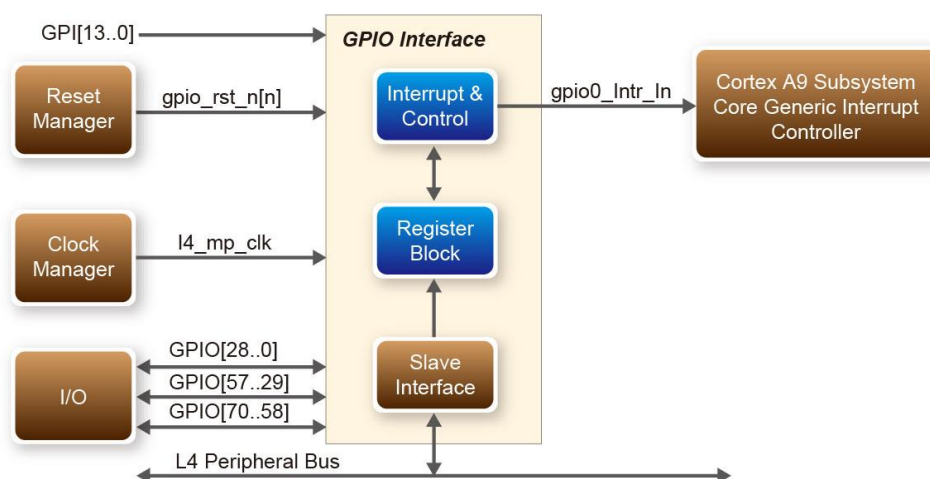

Figure 6-2 Block diagram of GPIO Interface

■ GPIO Register Block

The behavior of I/O pin is controlled by the registers in the register block. There are three 32-bit registers in the GPIO controller used in this demonstration. The registers are:

- **gpio_swporta_dr**: write output data to output I/O pin
- **gpio_swporta_ddr**: configure the direction of I/O pin
- **gpio_ext_porta**: read input data of I/O input pin

The **gpio_swporta_ddr** configures the LED pin as output pin and drives it high or low by writing data to the **gpio_swporta_dr** register. The first bit (least significant bit) of **gpio_swporta_dr** controls the direction of first IO pin in the associated GPIO controller and the second bit controls the direction of second IO pin in the associated GPIO controller and so on. The value "1" in the register bit indicates the I/O direction is output, while the value "0" in the register bit indicates the I/O direction is input.

The first bit of **gpio_swporta_dr** register controls the output value of first I/O pin in the associated GPIO controller, the second bit controls the output value of second I/O pin in the associated GPIO controller and so on. The value "1" in the register bit indicates the output value is high, and the value "0" indicates the output value is low.

The status of KEY can be queried by reading the value of **gpio_ext_porta** register. The first bit represents the input status of first IO pin in the associated GPIO controller, and the second bit represents the input status of second IO pin in the associated GPIO controller and so on. The value "1" in the register bit indicates the input state is high, and the value "0" indicates the input state is low.

■ GPIO Register Address Mapping

The registers of HPS peripherals are mapped to HPS base address space 0xFC000000 with 64KB size. The registers of the GPIO1 controller are mapped to the base address 0xFF708000 with 4KB size, and the registers of the GPIO2 controller are mapped to the base address 0xFF70A000 with 4KB size, as shown in **Figure 6-3**.

HPS

Identifier: HPS
Access: R/W
Description: Address map for the HHP HPS system-domain

Title	Identifier	Offset
Reserved		0x0
QSPI Flash Controller Module	QSPIREGS	0xFF705000
Register		0xFF705100
...
...
ACPI ID Mapper Registers	ACPIDMAP	...
GPIO Module	GPIO0	0xFF708000
Reserved		0xFF708080
GPIO Module	GPIO1	0xFF709000
Reserved		0xFF709080
GPIO Module	GPIO2	0xFF70A000
Reserved		0xFF70A080
L3 Cache	...	0xFF800000
...	...	0xFF880000
NAND Controller Module Data (AXI Slave)	NANDE	...
EMAC Module	EMAC1	0xFF702000

Figure 6-3 GPIO address map

■ Software API

Developers can use the following software API to access the register of GPIO controller.

- open: open memory mapped device driver
- mmap: map physical memory to user space
- alt_read_word: read a value from a specified register
- alt_write_word: write a value into a specified register
- munmap: clean up memory mapping
- close: close device driver.

Developers can also use the following MACRO to access the register

- alt_setbits_word: set specified bit value to one for a specified register
- alt_clrbits_word: set specified bit value to zero for a specified register

The program must include the following header files to use the above API to access the registers of GPIO controller.

```
#include <stdio.h>
#include <unistd.h>
#include <fcntl.h>
```

```
#include <sys/mman.h>
#include "hwlib.h"
#include "social/social.h"
#include "social/hps.h"
#include "social/alt_gpio.h"
```

■ **LED and KEY Control**

Figure 6-4 shows the HPS users LED and KEY pin assignment for the DE0-NANO-SoC board. The LED is connected to HPS_GPIO53 and the KEY is connected to HPS_GPIO54. They are controlled by the GPIO1 controller, which also controls HPS_GPIO29 ~ HPS_GPIO57.

HPS_GPIO53	A20	HPS_LED
HPS_GPIO54	J18	HPS_KEY

Figure 6-4 Pin assignment of LED and KEY

Figure 6-5 shows the **gpio_swporta_ddr** register of the GPIO1 controller. The bit-0 controls the pin direction of HPS_GPIO29. The bit-24 controls the pin direction of HPS_GPIO53, which connects to HPS_LED, the bit-25 controls the pin direction of HPS_GPIO54, which connects to HPS_KEY, and so on. The pin direction of HPS_LED and HPS_KEY are controlled by the bit-24 and bit-25 in the **gpio_swporta_ddr** register of the GPIO1 controller, respectively. Similarly, the output status of HPS_LED is controlled by the bit-24 in the **gpio_swporta_dr** register of the GPIO1 controller. The status of KEY can be queried by reading the value of the bit-24 in the **gpio_ext_porta** register of the GPIO1 controller.

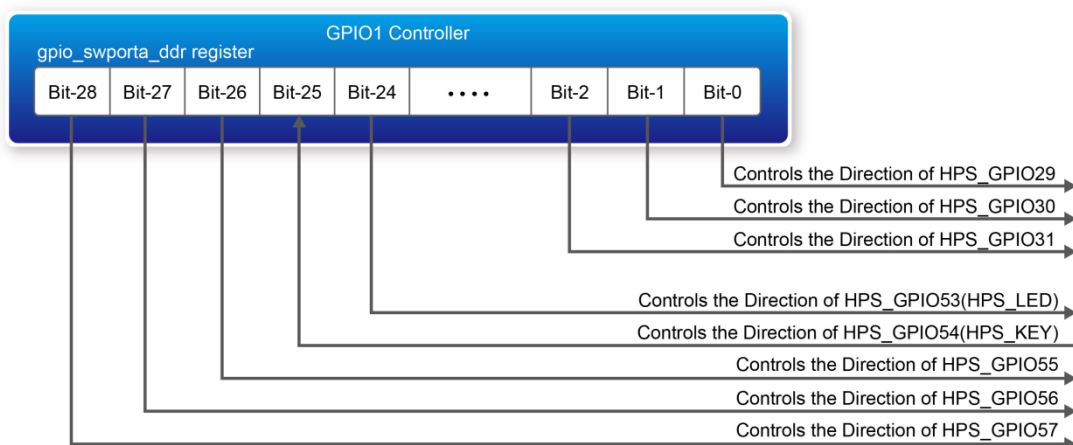

Figure 6-5 gpio_swporta_ddr register in the GPIO1 controller

The following mask is defined in the demo code to control LED and KEY direction and LED's output value.

```
#define USER_IO_DIR      (0x01000000)

#define BIT_LED          (0x01000000)

#define BUTTON_MASK     (0x02000000)
```

The following statement is used to configure the LED associated pins as output pins.

```
alt_setbits_word( ( virtual_base +
( ( uint32_t)( ALT_GPIO1_SWPORTA_DDR_ADDR ) &
( uint32_t)( HW_REGS_MASK ) ), USER\_IO\_DIR );
```

The following statement is used to turn on the LED.

```
alt_setbits_word( ( virtual_base +
( ( uint32_t)( ALT_GPIO1_SWPORTA_DR_ADDR ) &
( uint32_t)( HW_REGS_MASK ) ), BIT\_LED );
```

The following statement is used to read the content of **gpio_ext_porta** register. The bit mask is used to check the status of the key.

```
alt_read_word( ( virtual_base +
( ( uint32_t)( ALT_GPIO1_EXT_PORTA_ADDR ) &
( uint32_t)( HW_REGS_MASK ) ) );
```

■ Demonstration Source Code

- Build tool: Altera SoC EDS V14.0
- Project directory: \Demonstration\SoC\hps_gpio
- Binary file: hps_gpio
- Build command: make ('make clean' to remove all temporal files)
- Execute command: ./hps_gpio

■ Demonstration Setup

- Connect a USB cable to the USB-to-UART connector (J4) on the DE0-Nano-SoC board and the host PC.
- Copy the executable file "**hps_gpio**" into the microSD card under the **"/home/root"** folder in Linux.

- Insert the booting micro SD card into the DE0-Nano-SoC board.
- Power on the DE0-Nano-SoC board.
- Launch PuTTY and establish connection to the UART port of Putty. Type "root" to login Altera Yocto Linux.
- Type `"/hps_gpio "` in the UART terminal of PuTTY to start the program.

```
root@socfpga:~# ./hps_gpio
led test
the led flash 2 times
user key test
press key to control led
```

- HPS_LED will flash twice and users can control the user LED with push-button.
- Press HPS_KEY to light up HPS_LED.
- Press "CTRL + C" to terminate the application.

6.3 I2C Interfaced G-sensor

This demonstration shows how to control the G-sensor by accessing its registers through the built-in I2C kernel driver in [Altera Soc Yocto Powered Embedded Linux](#).

■ Function Block Diagram

Figure 6-6 shows the function block diagram of this demonstration. The G-sensor on the DE0-Nano-SoC board is connected to the **I2C0** controller in HPS. The G-Sensor I2C 7-bit device address is 0x53. The system I2C bus driver is used to access the register files in the G-sensor. The G-sensor interrupt signal is connected to the PIO controller. This demonstration uses polling method to read the register data.

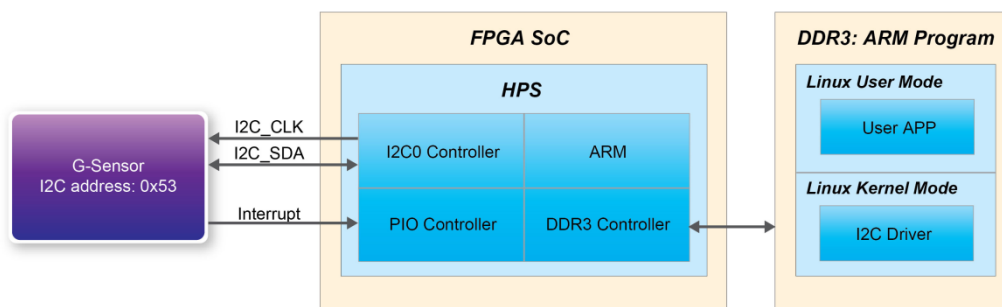

Figure 6-6 Block diagram of the G-sensor demonstration

■ I2C Driver

The procedures to read a register value from G-sensor register files by the existing I2C bus driver in the system are:

1. Open I2C bus driver "/dev/i2c-0": `file = open("/dev/i2c-0", O_RDWR);`
2. Specify G-sensor's I2C address 0x53: `ioctl(file, I2C_SLAVE, 0x53);`
3. Specify desired register index in g-sensor: `write(file, &Addr8, sizeof(unsigned char));`
4. Read one-byte register value: `read(file, &Data8, sizeof(unsigned char));`

The G-sensor I2C bus is connected to the I2C0 controller, as shown in the **Figure 6-7**. The driver name given is '/dev/i2c-0'.

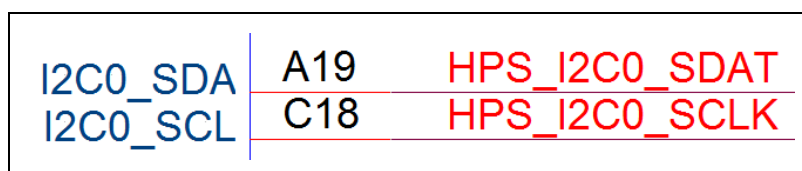

Figure 6-7 Connection of HPS I2C signals

The step 4 above can be changed to the following to write a value into a register.

`write(file, &Data8, sizeof(unsigned char));`

The step 4 above can also be changed to the following to read multiple byte values.

`read(file, &szData8, sizeof(szData8)); // where szData is an array of bytes`

The step 4 above can be changed to the following to write multiple byte values.

write(file, &szData8, sizeof(szData8)); // where szData is an array of bytes

■ G-sensor Control

The ADI ADXL345 provides I2C and SPI interfaces. I2C interface is selected by setting the CS pin to high on the DE0-Nano-SoC board.

The ADI ADXL345 G-sensor provides user-selectable resolution up to 13-bit \pm 16g. The resolution can be configured through the DATA_FORMAT(0x31) register. The data format in this demonstration is configured as:

- Full resolution mode
- \pm 16g range mode
- Left-justified mode

The X/Y/Z data value can be derived from the DATA0(0x32), DATA1(0x33), DATAY0(0x34), DATAY1(0x35), DATAZ0(0x36), and DATA1(0x37) registers. The DATA0 represents the least significant byte and the DATA1 represents the most significant byte. It is recommended to perform multiple-byte read of all registers to prevent change in data between sequential registers read. The following statement reads 6 bytes of X, Y, or Z value.

read(file, szData8, sizeof(szData8)); // where szData is an array of six-bytes

■ Demonstration Source Code

- Build tool: Altera SoC EDS v14.0
- Project directory: \Demonstration\SoC\hps_gsensor
- Binary file: gsensor
- Build command: make ('make clean' to remove all temporal files)
- Execute command: ./gsensor [loop count]

■ Demonstration Setup

- Connect a USB cable to the USB-to-UART connector (J4) on the DE0-Nano-SoC board and the host PC.
- Copy the executable file "**gsensor**" into the microSD card under the "**/home/root**" folder in Linux.
- Insert the booting microSD card into the DE0-Nano-SoC board.
- Power on the DE0-Nano-SoC board.

- Launch PuTTY to establish connection to the UART port of DE0-Nano-SoC board. Type "root" to login Yocto Linux.
- Execute `./gsensor` in the UART terminal of PuTTY to start the G-sensor polling.
- The demo program will show the X, Y, and Z values in the PuTTY, as shown in **Figure 6-8**.

```
root@socfpga:~# ./gsensor
===== gsensor test =====
id=E5h
[1]X=80 mg, Y=-40 mg, Z=924 mg
[2]X=76 mg, Y=-32 mg, Z=972 mg
[3]X=76 mg, Y=-36 mg, Z=964 mg
[4]X=84 mg, Y=-36 mg, Z=976 mg
[5]X=76 mg, Y=-40 mg, Z=964 mg
[6]X=76 mg, Y=-40 mg, Z=972 mg
```

Figure 6-8 Terminal output of the G-sensor demonstration

- Press "CTRL + C" to terminate the program.

Chapter 7

Examples for using both HPS SoC and FPGA

Although HPS and FPGA can operate independently, they are tightly coupled via a high-bandwidth system interconnect built from high-performance ARM AMBA® AXITM bus bridges. Both FPGA fabric and HPS can access to each other via these interconnect bridges. This chapter provides demonstrations on how to achieve superior performance and lower latency through these interconnect bridges when comparing to solutions containing a separate FPGA and discrete processor.

7.1 HPS Control FPGA LED

This demonstration shows how HPS controls the FPGA LED through Lightweight HPS-to-FPGA Bridge. The FPGA is configured by HPS through FPGA manager in HPS.

■ **A brief view on FPGA manager**

The FPGA manager in HPS configures the FPGA fabric from HPS. It also monitors the state of FPGA and drives or samples signals to or from the FPGA fabric. The command is provided to configure FPGA through the FPGA manager. The FPGA configuration data is stored in the file with .rbf extension. The MSEL[4:0] must be set to 00000 before executing the command on HPS.

■ **Function Block Diagram**

Figure 7-1 shows the block diagram of this demonstration. The HPS uses Lightweight HPS-to-FPGA AXI Bridge to communicate with FPGA. The hardware in FPGA part is built into Qsys. The data transferred through Lightweight HPS-to-FPGA Bridge is converted into Avalon-MM

master interface. The PIO Controller works as Avalon-MM slave in the system. They control the associated pins to change the state of LED. This is similar to a system using Nios II processor to control LED.

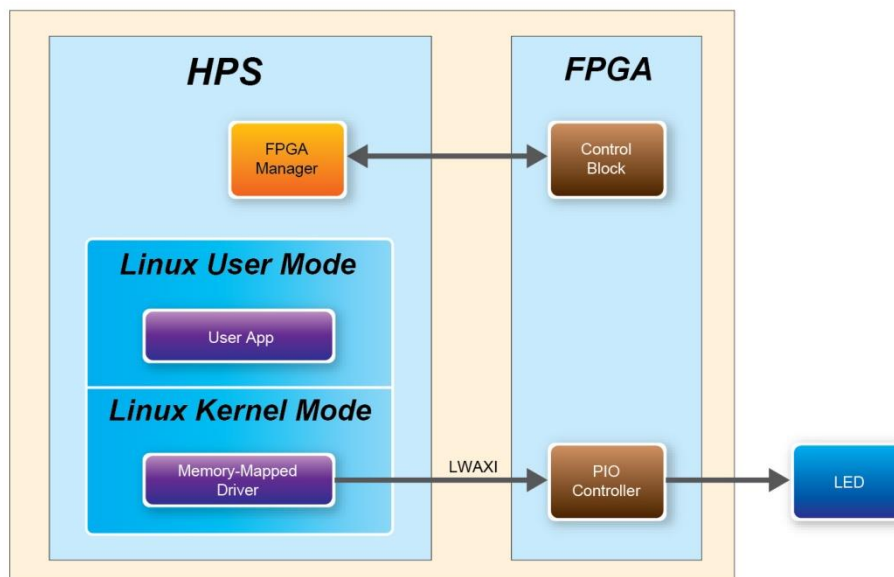

Figure 7-1 FPGA LED are controlled by HPS

■ LED Control Software Design

The Lightweight HPS-to-FPGA Bridge is a peripheral of HPS. The software running on Linux cannot access the physical address of the HPS peripheral. The physical address must be mapped to the user space before the peripheral can be accessed. Alternatively, a customized device driver module can be added to the kernel. The entire CSR span of HPS is mapped to access various registers within that span. The mapping function and the macro defined below can be reused if any other peripherals whose physical address is also in this span.

```
#define HW_REGS_BASE ( ALT_STM_OFST )
#define HW_REGS_SPAN ( 0x04000000 )
#define HW_REGS_MASK ( HW_REGS_SPAN - 1 )
```

The start address of Lightweight HPS-to-FPGA Bridge after mapping can be retrieved by ALT_LWFPGASLVS_OFST, which is defined in altera_hps hardware library. The slave IP connected to the bridge can then be accessed through the base address and the register offset in these IPs. For instance, the base address of the PIO slave IP in this system is 0x0001_0040, the direction control register offset is 0x01, and the data register offset is 0x00. The following statement is used to retrieve the base address of PIO slave IP.

```
h2p_lw_led_addr=virtual_base+( ( unsigned long  )( ALT_LWFPGASLVS_OFST
+ LED_PIO_BASE ) & ( unsigned long)( HW_REGS_MASK ) );
```

Considering this demonstration only needs to set the direction of PIO as output, which is the default direction of the PIO IP, the step above can be skipped. The following statement is used to set the output state of the PIO.

```
alt_write_word(h2p_lw_led_addr, Mask );
```

The Mask in the statement decides which bit in the data register of the PIO IP is high or low. The bits in data register decide the output state of the pins connected to the LED.

■ Demonstration Source Code

- Build tool: Altera SoC EDS V14.0
- Project directory: \Demonstration\ SoC_FPGA\HPS_CONTROL_FPGA_LED
- FPGA configuration file : HPS_CONTROL_FPGA_LED.rbf
- Binary file: HPS_CONTROL_FPGA_LED
- Build app command: make ('make clean' to remove all temporal files)
- Execute app command:./ HPS_CONTROL_FPGA_LED

■ Demonstration Setup

- Quartus II and SoCEDs must be installed on the host PC.
- The MSEL[4:0] is set to 00000.
- Connect a USB cable to the USB-to-UART connector (J4) on the DE0-Nano-SoC board and the host PC.
- Copy the executable files "HPS_CONTROL_FPGA_LED" and the FPGA configuration file " HPS_CONTROL_FPGA_LED.rbf " into the microSD card under the **"/home/root"** folder in Linux.
- Insert the booting microSD card into the DE0-Nano-SoC board. Please refer to the chapter 5 "Running Linux on the DE0-Nano-SoC board" on *DE0-Nano-SoC _Getting_Started_Guide.pdf* on how to build a booting microSD card image.
- Power on the DE0-Nano-SoC board.
- Launch PuTTY to establish connection to the UART port of the DE0-Nano-SoC board. Type **"root"** to login Altera Yocto Linux.
- Execute "dd if= HPS_CONTROL_FPGA_LED.rbf of=/dev/fpga0 bs=1M" in the UART terminal of PuTTY to configure the FPGA through the FPGA manager. After the configuration is successful, the message shown in **Figure 7-2** will be displayed in the

terminal.

```
root@socfpga:~# dd if=HPS_CONTROL_FPGA_LED.rbf of=/dev/fpga0 bs=1M
4+1 records in
4+1 records out
root@socfpga:~#
root@socfpga:~#
```

Figure 7-2 Running command to configure the FPGA

- Execute `"/HPS_CONTROL_FPGA_LED"` in the UART terminal of PuTTY to start the program.
- The message shown in **Figure 7-3**, will be displayed in the terminal. The LED[7:0] will be flashing.

```
root@socfpga:~# ./HPS_CONTROL_FPGA_LED
LED ON
LED OFF
LED ON
LED OFF
LED ON
LED OFF
LED ON
LED OFF
LED ON
LED OFF
LED ON
LED OFF
LED ON
LED OFF
```

Figure 7-3 Running result in the terminal of PuTTY

- Press "CTRL + C" to terminate the program.

Programming the EPCS Device

This chapter describes how to program the serial configuration (EPCS) device with Serial Flash Loader (SFL) function via the JTAG interface. Users can program EPCS devices with a JTAG indirect configuration (.jic) file, which is converted from a user-specified SRAM object file (.sof) in Quartus. The .sof file is generated after the project compilation is successful. The steps of converting .sof to .jic in Quartus II are listed below.

8.1 Before Programming Begins

The FPGA should be set to AS x1 mode i.e. MSEL[4..0] = “10010” to use the Flash as a FPGA configuration device, as shown in **Figure 8-1**.

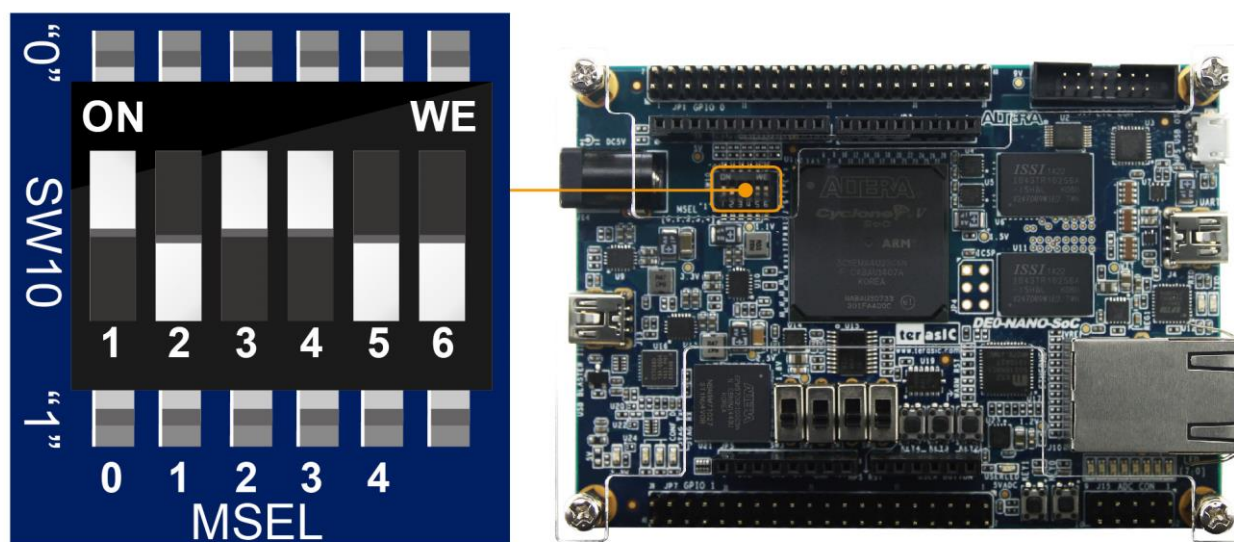

Figure 8-1 DIP switch (SW10) setting of Active Serial (AS) mode

8.2 Convert .SOF File to .JIC File

1. Choose **Convert Programming Files** from the File menu of Quartus II, as shown in **Figure 8-2**.

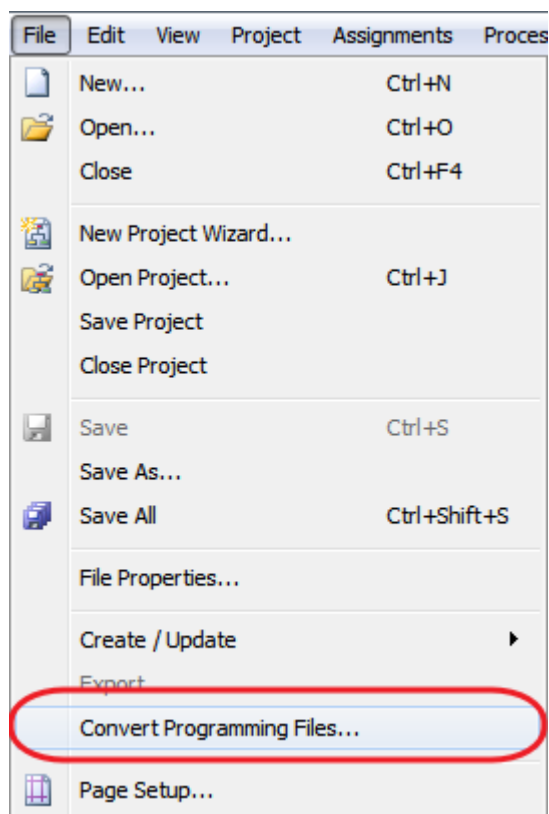

Figure 8-2 File menu of Quartus II

2. Select **JTAG Indirect Configuration File (.jic)** from the **Programming file type** field in the dialog of Convert Programming Files.
3. Choose **EPCS64**
4. from the **Configuration device** field.
5. Choose **Active Serial** from the **Mode** field.
6. Browse to the target directory from the **File name** field and specify the name of output file.
7. Click on the **SOF data** in the section of **Input files to convert**, as shown in **Figure 8-3**.

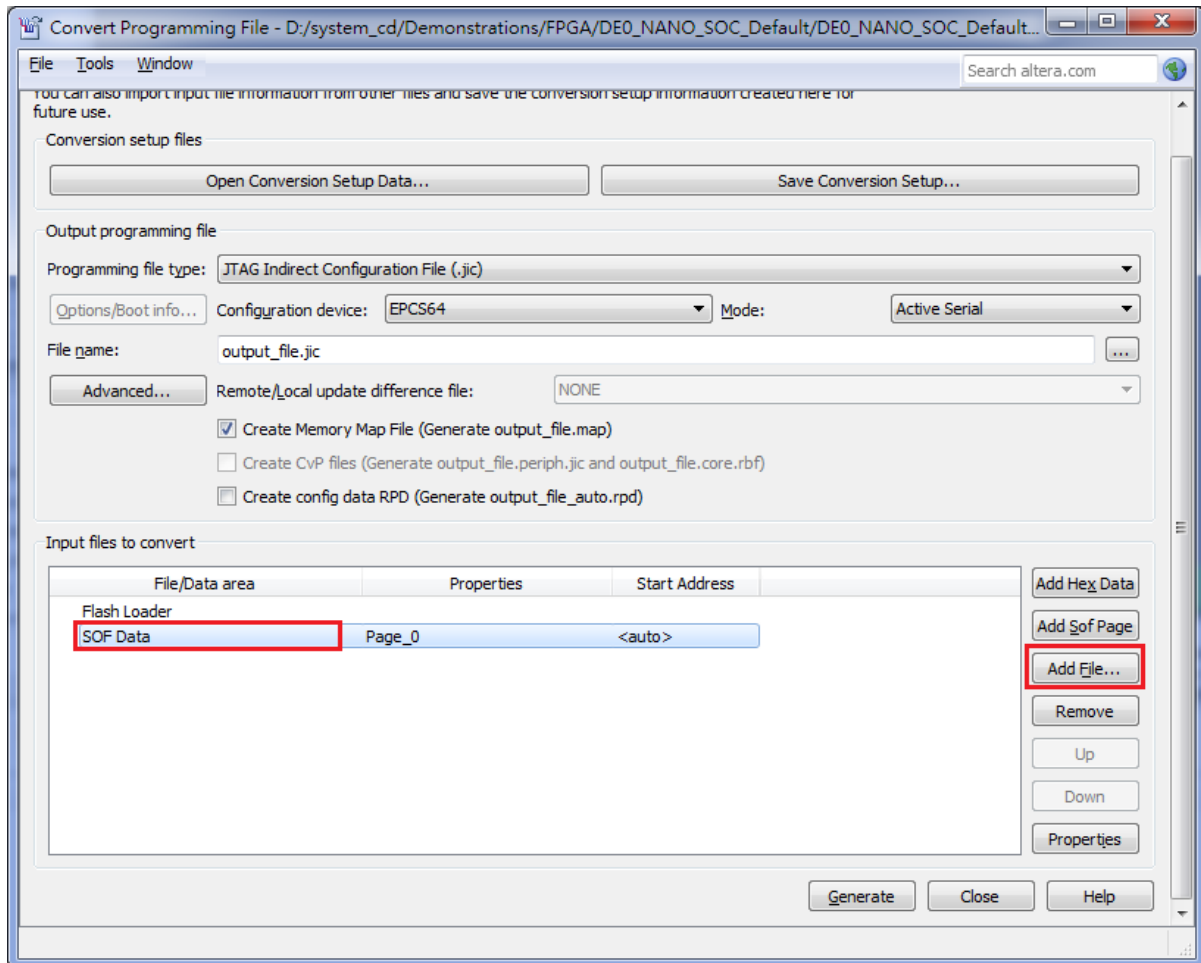

Figure 8-3 Dialog of “Convert Programming Files”

8. Click **Add File**.
9. Select the .sof to be converted to a .jic file from the Open File dialog.
10. Click **Open**.
11. Click on the **Flash Loader** and click **Add Device**, as shown in **Figure 8-4**.
12. Click **OK** and the **Select Devices** page will appear.

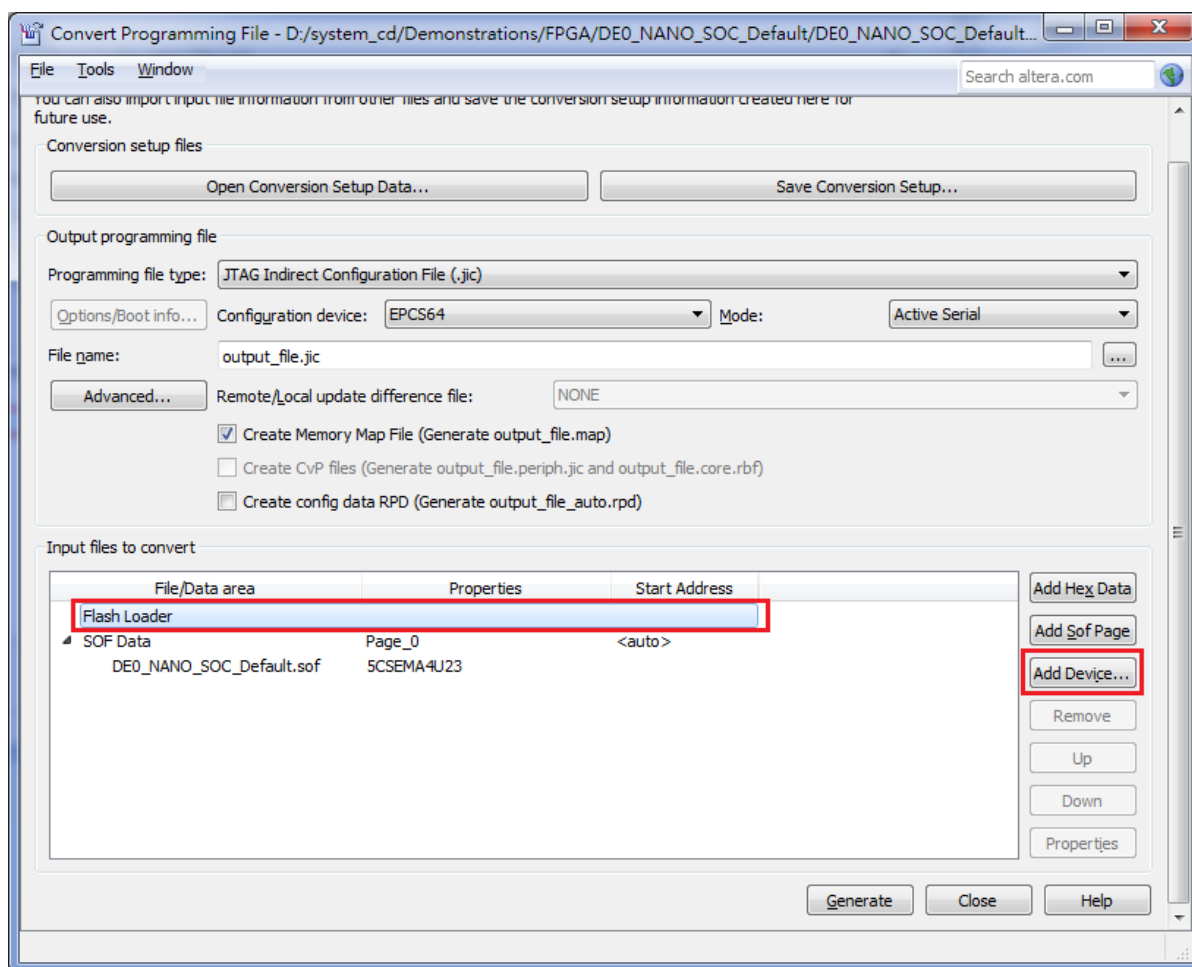

Figure 8-4 Click on the “Flash Loader”

13. Select the targeted FPGA to be programmed into the Flash Loader, as shown in **Figure 8-5**.
14. Click **OK** and the **Convert Programming Files** page will appear, as shown in **Figure 8-6**.
15. Click **Generate**.

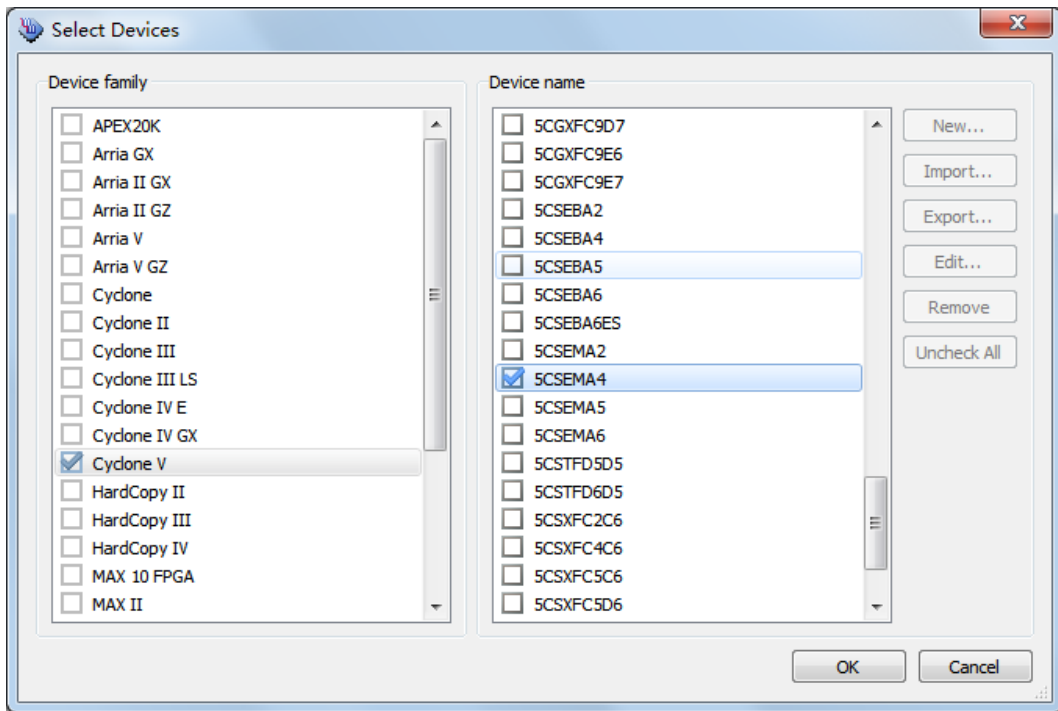

Figure 8-5 “Select Devices” page

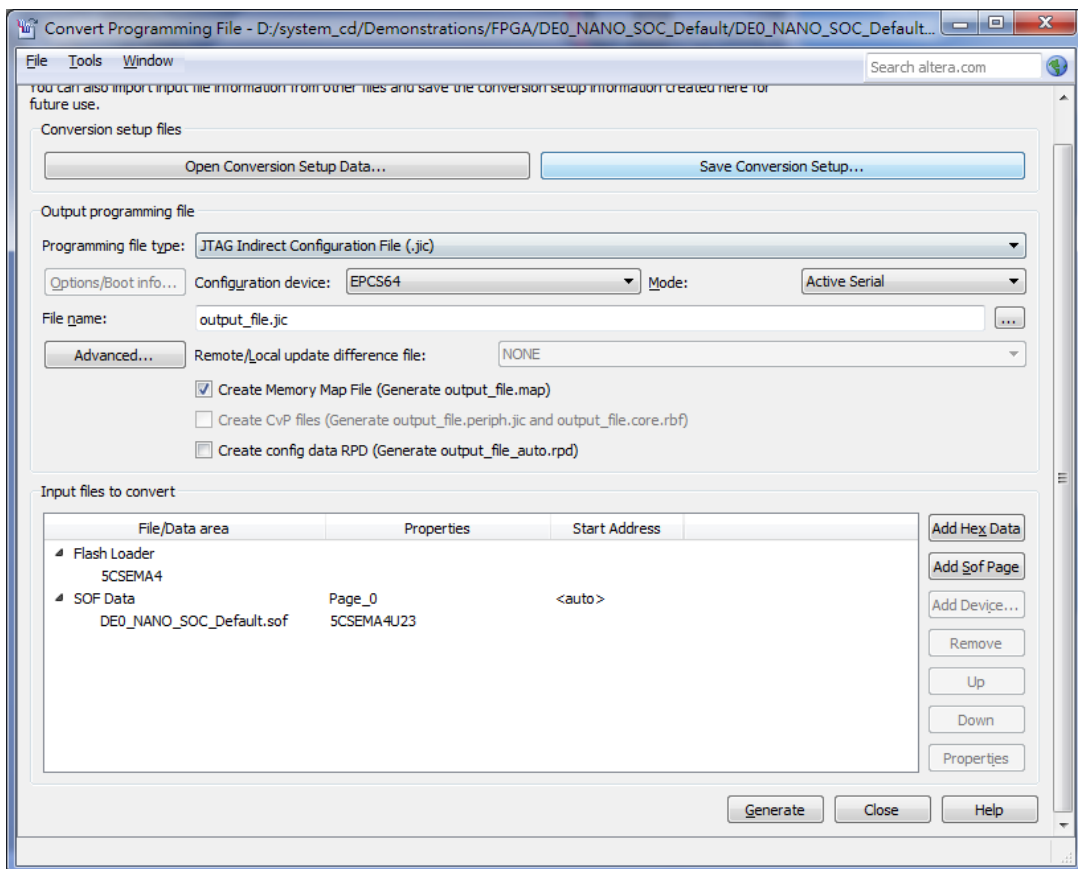

Figure 8-6 “Convert Programming Files” page after selecting the device

8.3 Write JIC File into the EPCS Device

When the conversion of SOF-to-JIC file is complete, please follow the steps below to program the EPCS device with the .jic file created in Quartus II Programmer.

1. Set MSEL[4..0] = "10010"
2. Choose **Programmer** from the Tools menu and the **Chain.cdf** window will appear.
3. Click **Auto Detect** and then select the correct device(SCSEMA4). Both FPGA device and HPS should be detected, as shown in **Figure 8-7**.
4. Double click the red rectangle region shown in **Figure 8-7** and the **Select New Programming File** page will appear. Select the .jic file to be programmed.
5. Program the EPCS device by clicking the corresponding **Program/Configure** box. A factory default SFL image will be loaded, as shown in **Figure 8-8**.
6. Click **Start** to program the EPCS device.

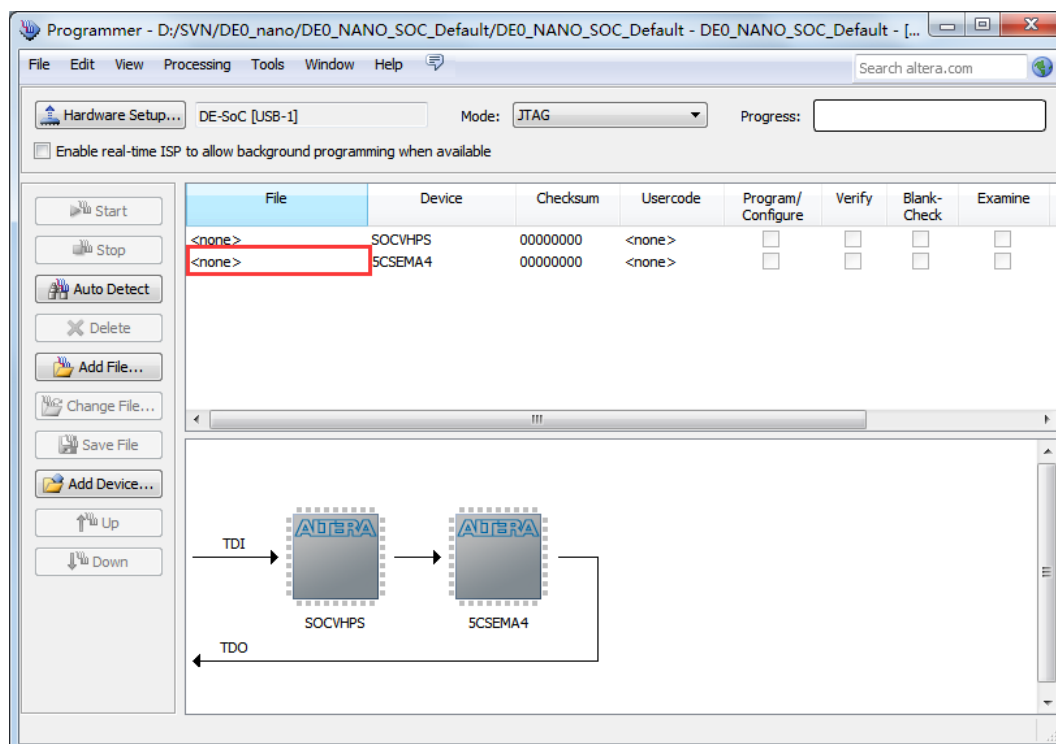

Figure 8-7 Two devices are detected in the Quartus II Programmer

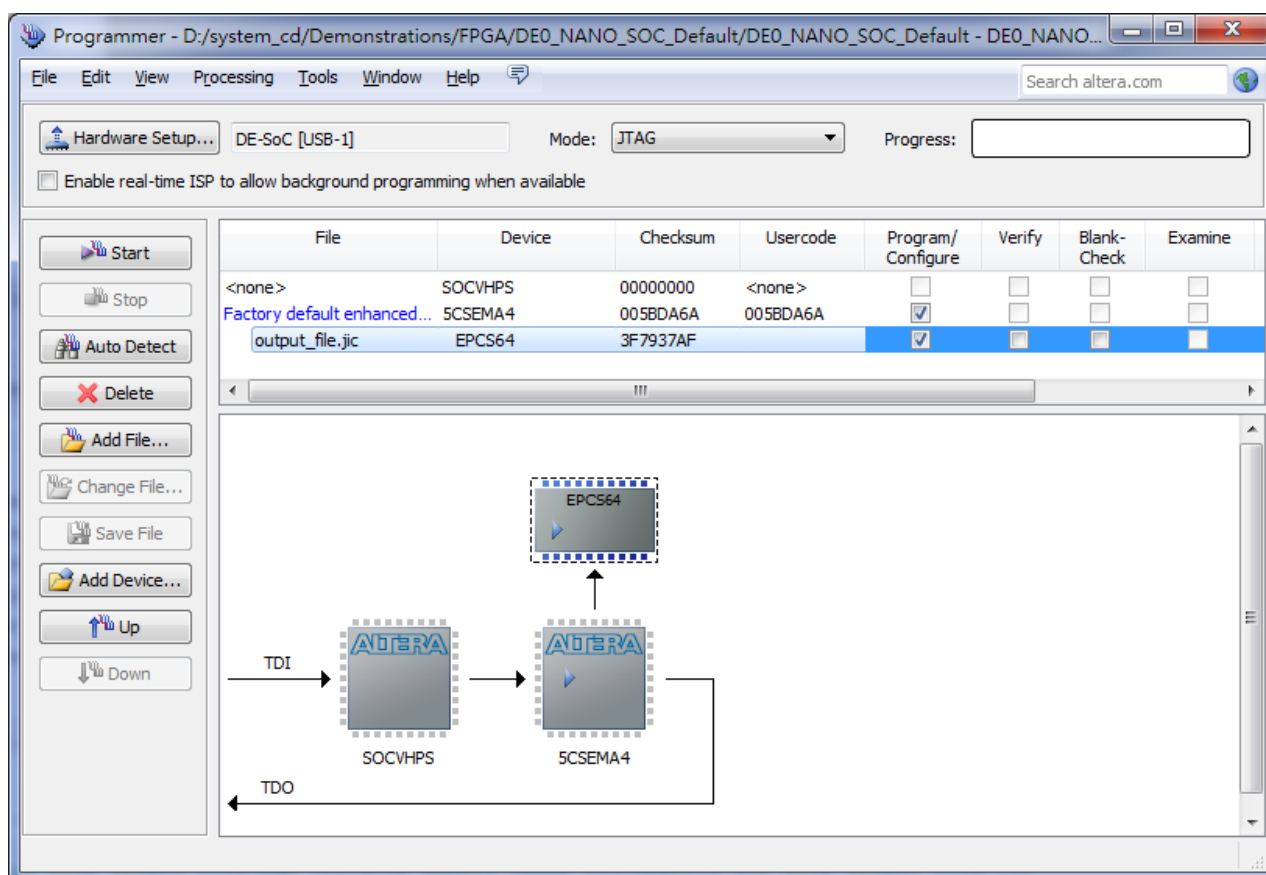

Figure 8-8 Quartus II programmer window with one .jic file

8.4 Erase the EPCS Device

The steps to erase the existing file in the EPCS device are:

1. Set MSEL[4..0] = "10010"
2. Choose **Programmer** from the **Tools** menu and the **Chain.cdf** window will appear.
3. Click **Auto Detect**, and then select correct device, both FPGA device and HPS will be detected. (See **Figure 8-7**)
4. Double click the red rectangle region shown in **Figure 8-7**, and the **Select New Programming File** page will appear. Select the correct .jic file.
5. Erase the EPCS device by clicking the corresponding **Erase** box. A factory default SFL image will be loaded, as shown in **Figure 8-9**.

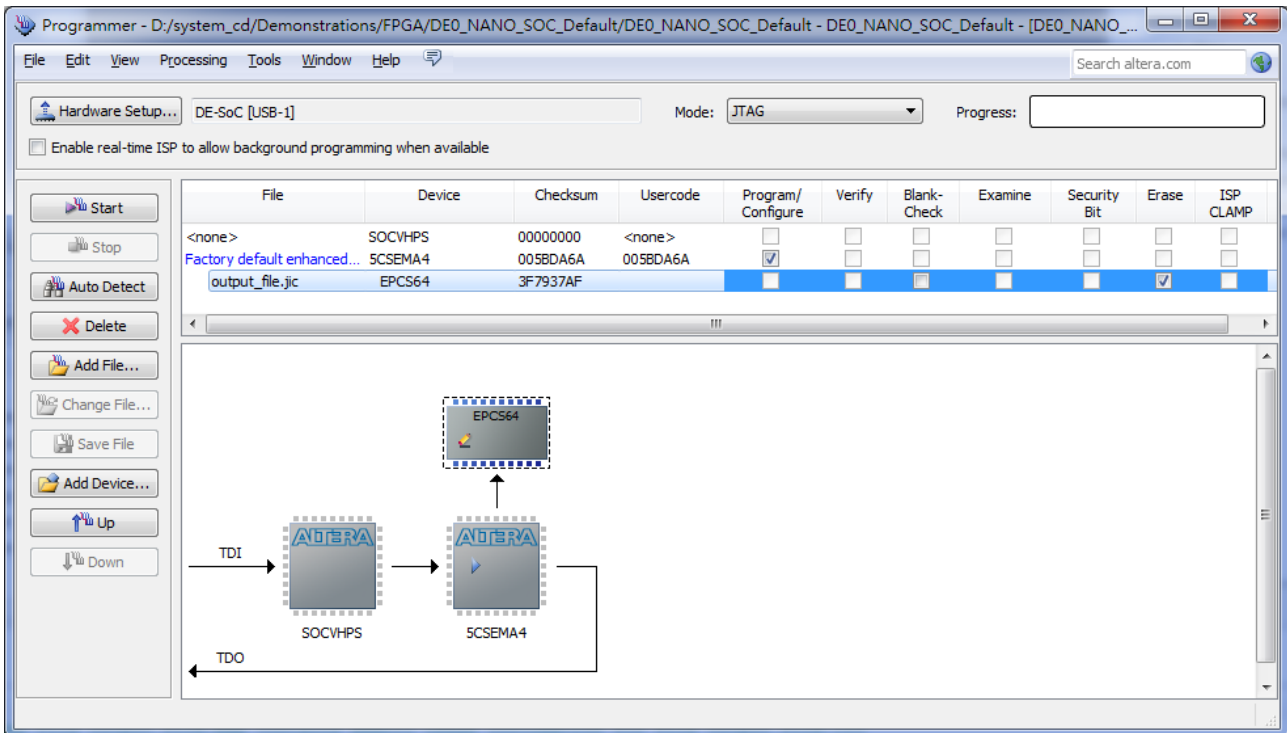

Figure 8-9 Erase the EPCS device in Quartus II Programmer

- Click **Start** to erase the EPCS device.

8.5 EPCS Programming via nios-2-flash-programmer

Before programming the EPCS via nios-2-flash-programmer, users must add an EPCS patch file nios-flash-override.txt into the Nios II EDS folder. The patch file is available in the folder Demonstation\EPCS_Patch of DE0-Nano-SoC System CD. Please copy this file to the folder [QuartusInstalledFolder]\nios2eds\bin (e.g. C:\altera\14.0\nios2eds\bin)

If the patch file is not included into the Nios II EDS folder, an error will occur as shown in **Figure 8-10**.

```
Using cable "USB-Blaster [USB-01]", device 1, instance 0x00
Resetting and pausing target processor: OK
No EPCS layout data - looking for section [EPCS-010216]
Unable to use EPCS device
Leaving target processor paused
```

Figure 8-10 Error Message “No EPCS Layout Data”.

8.6 Nios II Boot from EPCS Device in Quartus II v13.1 or later

There is a known problem in Quartus II software that the Quartus Programmer must be used to program the EPCS device on DE0-Nano-SoC board.

Please refer to Altera's website [here](#) with details step by step.

9.1 What's different between the DE0-Nano-SoC kit and the Atlas-SoC kit?

The hardware is the same for the DE0-Nano-SoC kit and the Atlas-SoC kit. The only difference is the getting-started process for the two kits. Users can freely use the DE0-Nano-SoC kit resources on the Atlas-SoC kit and vice versa. For more details on the Atlas-SoC kit, please visit:

<http://www.rocketboards.org/atlas-soc>

10.1 Revision History

<i>Version</i>	<i>Change Log</i>
V1.0	Initial Version (Preliminary)
V1.1	Minor corrections: fixing typos and broken links
V1.2	Minor corrections: fixing typos and broken links and adding Altera Atlas kit's description
V1.3	Minor corrections: fixing Table 3-2.
V1.4	Add GPIO pin Arrangement (Figure 3-18)
V1.5	Minor corrections: fixing typos and broken links
V1.6	Change EPCS Device

Copyright © 2015 Terasic Inc. All rights reserved.