

SECTION A-A

**Dimensions:**  
mm  
[inches]

**NOTES:**

1. PURCHASED ITEM INCLUDES CASE, RUBBER FEET AND SCREWS (FOR SECURING OPTIONAL CAMERA).
2. DETAILED ASSEMBLY INSTRUCTIONS AVAILABLE FOR CASE AND OPTIONAL CAMERA CARD.



MC-RP002

[www.farnell.com](http://www.farnell.com)

**INSTALLING THE RASPBERRY PI B+ INTO THE MC-RP002 ENCLOSURE**

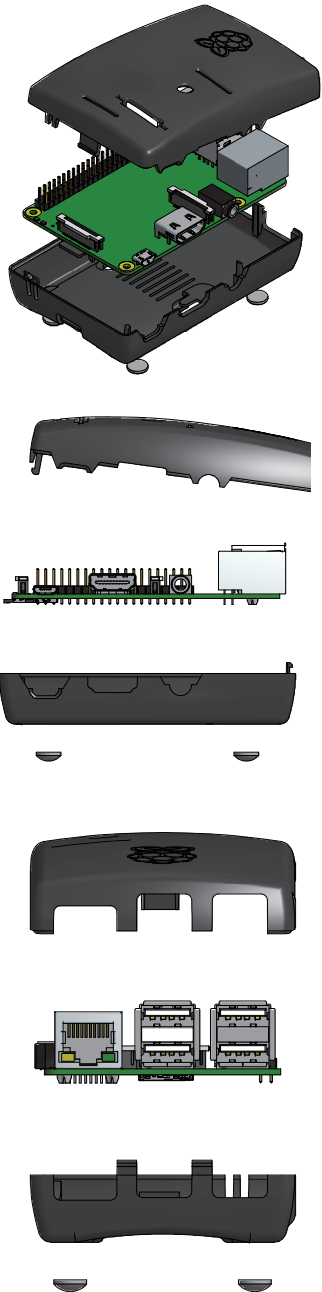

**STEP 1**  
TAKE THE BOTTOM PART OF THE ENCLOSURE AND INSERT THE DEVELOPMENT BOARD ON AN ANGLE AGAINST THE STATIONARY CLIPS.

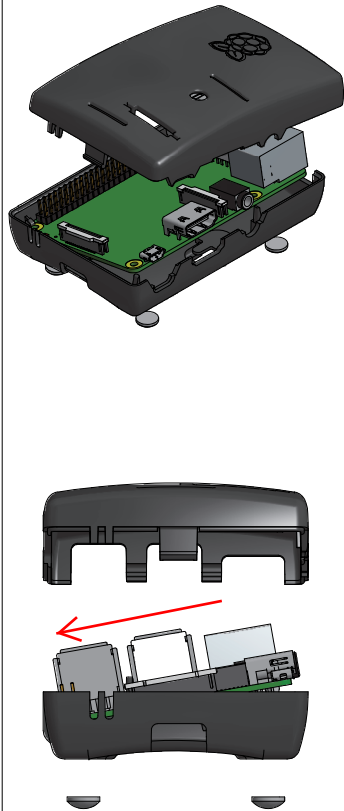

**STEP 2**  
PUSH DOWN FIRMLY ON THE HDMI PORT UNTIL YOU HEAR THE BOARD CLICK IN PLACE.

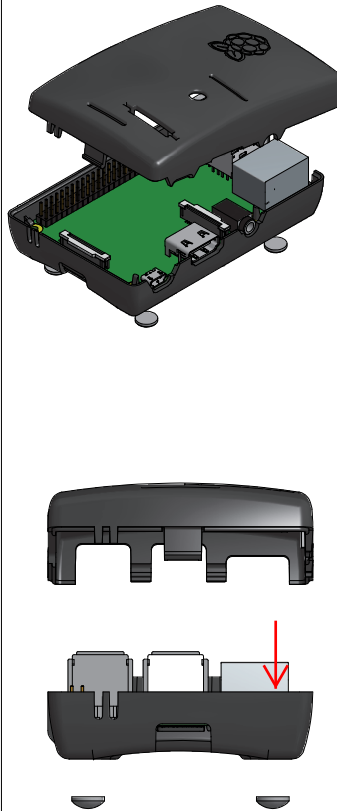

**STEP 3**  
TAKE THE TOP PART OF THE ENCLOSURE AND LINE UP THE TWO CLIPS ON THE USB SIDE ON AN ANGLE.



**STEP 4**  
TO SECURE ENCLOSURE PUSH DOWN ON THE OUTER TOP EDGE UNTIL YOU HEAR A CLICKING SOUND.  
  
ON THE BOTTOM OF THE ENCLOSURE, PLACE RUBBER ADHESIVE FEET IN THE CIRCLES



TO DISASSEMBLE, PUSH IN THE TWO TABS ON THE BOTTOM CASE (ON THE USB SIDE) AND PULL THE TOP CASE UP.



**multicomp**

MC-RP002 ASSEMBLY

## OPTION #1

AFTER THE PI BOARD HAS BEEN CONNECTED TO THE BOTTOM PORTION OF THE CASE, TAKE THE CAMERA AND RUN IT THROUGH THE TOP OF THE CASE CONNECTING IT TO THE PROPER PORT ON THE PI.

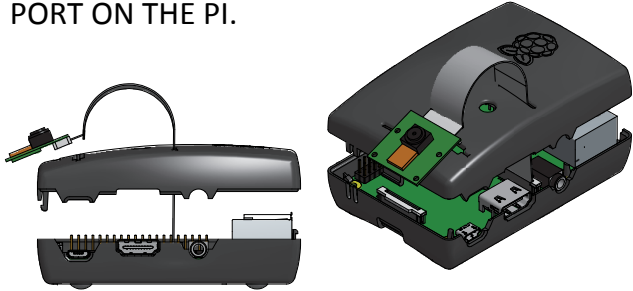

YOU CAN NOW CLOSE THE CASE, MAKING SURE THE CABLE AND CAMERA ARE CLEAR SO YOU DO NOT DAMAGE THEM WHEN CLOSING THE CASE.



TAKE THE CAMERA AND INSERT IT INTO THE SLOT SO THE CAMERA IS ORIENTATED AS SEEN IN THE PICTURE.



## OPTION #2

YOU WILL NEED THE TOP OF THE CASE, YOUR PI CAMERA, TWO SUPPLIED SELF-TAPPING SCREWS #2X3/16" OR (M2X4.5mm) AND A #1 SCREW DRIVER.

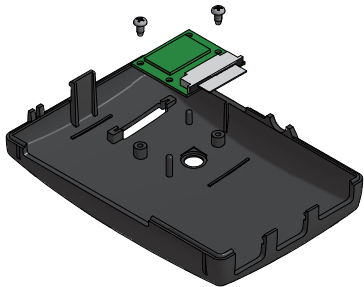

PLACE THE CAMERA ON THE POSTS MAKING SURE THE CAMERA LENS SITS IN THE CUTOUT OF THE CASE.

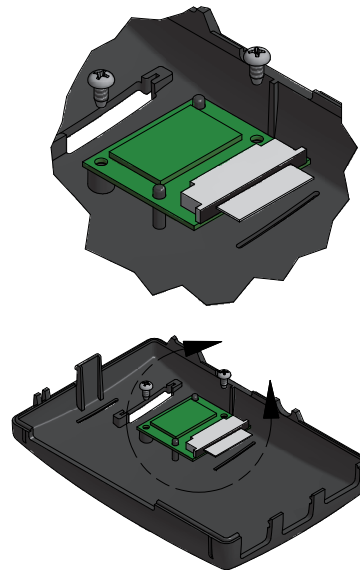

INSTALL THE TWO SCREWS INTO THE OTHER TWO POSTS, SECURING THE CAMERA INTO PLACE.

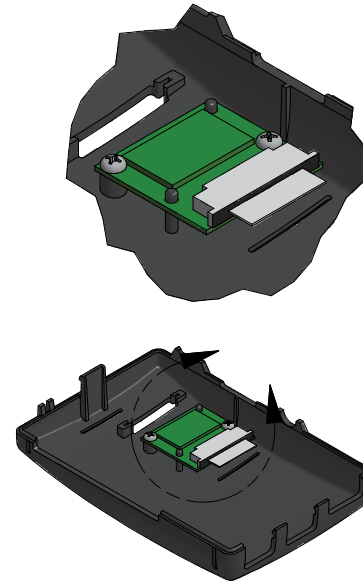

CONNECT THE CAMERA CABLE TO THE PI

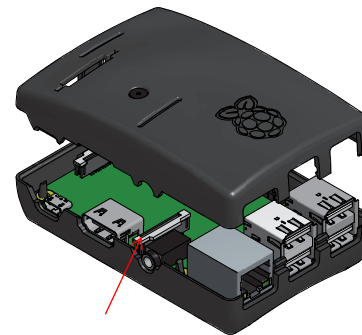

YOU CAN NOW CLOSE THE CASE, MAKING SURE THE CAMERA CABLE IS CLEAR SO YOU DO NOT DAMAGE IT WHEN CLOSING THE CASE.



multicom

MC-RP002

CAMERA ASSEMBLY