

# FRDM-KE04Z User's Guide

## User Guide

by: Wang Peng

### 1 Overview

The Freescale Freedom development platform is an ideal evaluation and development tool for rapid prototyping of microcontroller-based applications. The hardware design is form-factor compatible with popular third-party hardware designed to work with Arduino™ and Arduino-compatible boards.

The Freescale KE04Z Freedom board (FRDM-KE04Z) is a simple, yet sophisticated design featuring a Kinetis E series microcontroller KE04Z, a 5 V microcontroller built on the ARM® Cortex®-M0+ core.

The Kinetis E series is the most scalable portfolio of low-power, high-robustness, mixed signal 32-bit ARM Cortex-M0+ MCUs running up to 48 MHz in the industry. It supports power supply voltage range from 2.7 V to 5.5 V, ambient operating temperature ranges from -40 °C to 105 °C and includes up to 128 KB flash.

The FRDM-KE04Z board includes the Freescale open standard embedded serial and debug adapter known as OpenSDA. This circuit offers several options for serial communications, flash programming and run-control debugging to the user.

There are also many software development tool options available to the user. Choices include CodeWarrior for Microcontrollers, IAR Embedded Workbench, Keil MDK

### Contents

1	Overview.....	1
2	Getting started.....	2
3	FRDM-KE04Z hardware overview.....	2
4	FRDM-KE04Z hardware description.....	4
4.1	Power supply.....	4
4.2	Serial and Debug Adapter (OpenSDA).....	5
4.2.1	Debugging interface.....	6
4.2.2	Virtual serial port.....	7
4.3	KE04Z microcontroller.....	7
4.3.1	Clock Source.....	7
4.4	Infrared port.....	8
4.5	Capacitive touch slider.....	9
4.6	Three-axis accelerometer.....	10
4.7	RGB LED.....	11
4.8	Input/Output headers.....	12
4.9	Arduino compatibility.....	13
5	References.....	13
6	Revision history.....	14

## Getting started

featuring the  $\mu$ Vision IDE, Red Suite from Code Red Technologies, Atollic TrueSTUDIO, Rowley Crossworks, and more.

All of these features are combined to give freedom to the user to rapidly prototype the embedded designs: a powerful microcontroller built on a very low-power core and SoC platform, easy-access to I/O with a large ecosystem of compatible hardware, a flexible programming and debug interface, and a large ecosystem of software development environments.

## 2 Getting started

Refer to the FRDM-KE04Z *Quick Start Package* for step-by-step instructions for getting started with the Freedom board. See *Quick Start Package and Software Lab* guides available on [freescale.com](http://freescale.com).

## 3 FRDM-KE04Z hardware overview

The FRDM-KE04Z hardware is a Freescale Freedom development platform microcontroller board assembled with the following features:

- Kinetis E Series KE04 family MCU MKE04Z8VFK4 in an 24 QFN package
- Onboard serial and debug adapter (OpenSDA)
- I/O headers for easy access to MCU I/O pins
- Freescale inertial sensor, MMA8451Q
- Capacitive touch slider
- Reset pushbutton
- RGB LED
- Infrared communication
- Motor control header for simple BLDC motor control on APMOTOR56F8000E

[Figure 1](#) shows the block diagram of FRDM-KE04Z board.

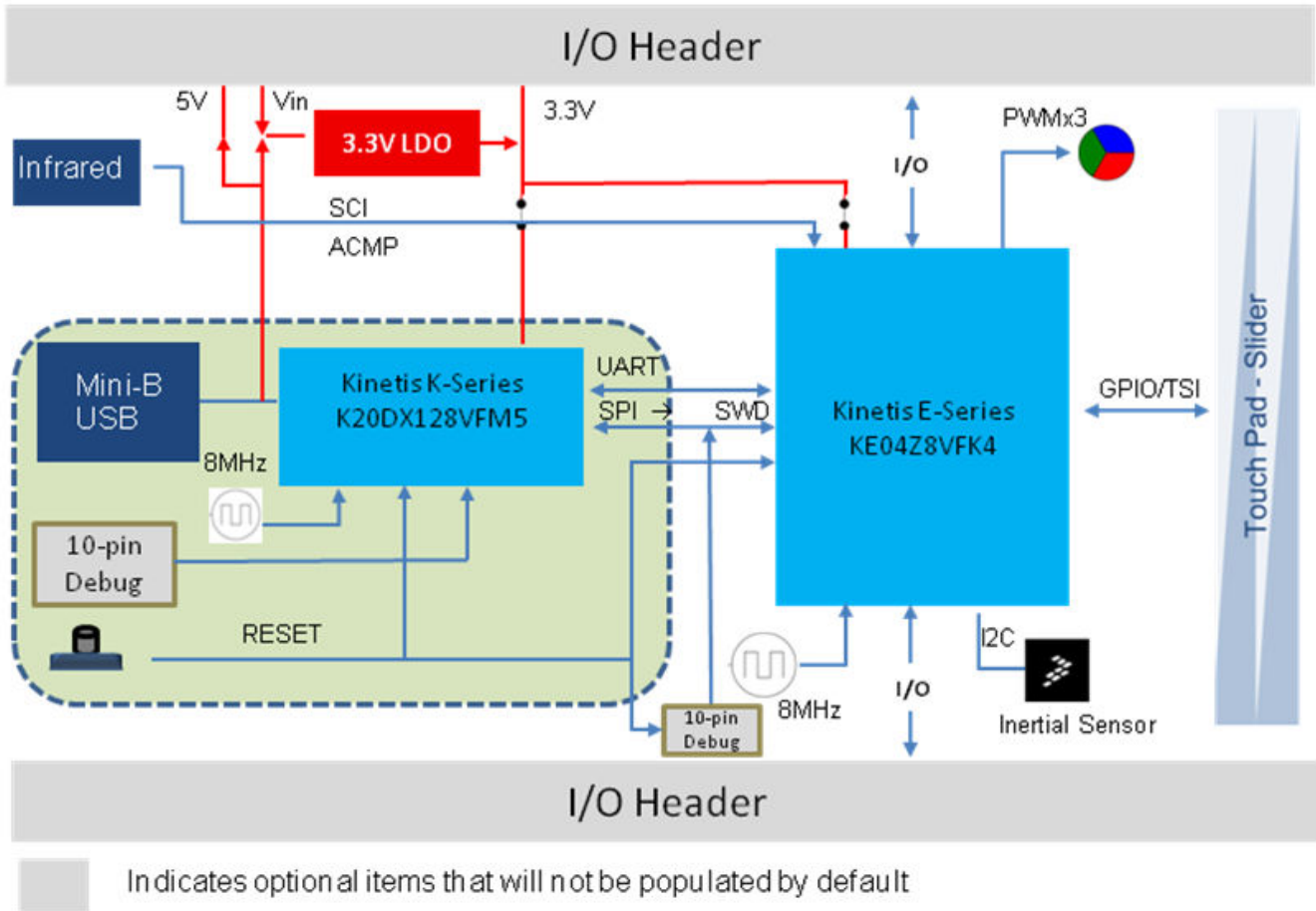

**Figure 1. FRDM-KE04Z block diagram**

The FRDM-KE04Z features two microcontrollers (MCUs): the target MCU and the serial and debug adapter (OpenSDA) MCU. The target MCU is a Kinetis E series KE04 family device, the KE04Z8VFK4. The OpenSDA MCU is a Kinetis K series K20 family device, the K20DX128VFM5.

Features of the KE04Z8VFK4 target MCU include:

- 32-bit [ARM Cortex-M0+](#) core
  - Up to 48 MHz operation
  - Single-cycle fast I/O access port
  - Aliased SRAM bitband region
- Memories
  - 8 KB flash
  - 1 KB SRAM
- System integration
  - Power management and mode controllers
  - Low-leakage wakeup unit
  - Bit manipulation engine (BME) for read-modify-write peripheral operations
- Clock
  - Clock generation module with FLL for system and CPU clock generation
  - 32 kHz internal reference clock
  - System oscillator supporting external crystal or resonator
  - Low-power 1 kHz RC oscillator for RTC and watchdog
- Analog peripherals
  - 12-bit SAR ADC
  - Two analog comparators

## FRDM-KE04Z hardware description

- Communication peripherals
  - One 8-bit serial peripheral interface (SPI)
  - One I<sup>2</sup>C module
  - One UART module
- Timers
  - One 6-channel FlexTimer module (FTM)
  - One 2-channel timer/PWM module
  - One 2-channel periodic interrupt timer (PIT)
  - Real-time clock (RTC)
  - System tick timer
  - One watchdog module
- Security
  - One CRC
- Human-Machine Interfaces (HMI)
  - General purpose input/output controller
  - Two 8-bit keyboard interrupt modules (KBI)
  - External interrupt (IRQ)

## 4 FRDM-KE04Z hardware description

### 4.1 Power supply

The FRDM-KE04Z offers a design with multiple power supply options. It can be powered from the USB connector, the VIN pin on the I/O header, an off-board 1.71–3.6 V supply from the 3.3 V pin on the I/O header or 3.3 V from motor control header. The USB and VIN supplies are regulated on-board using a 3.3 V linear regulator to produce the main power supply. The other two sources are not regulated onboard. [Figure 2](#) shows the schematic drawing for the power supply inputs and the onboard voltage regulator.

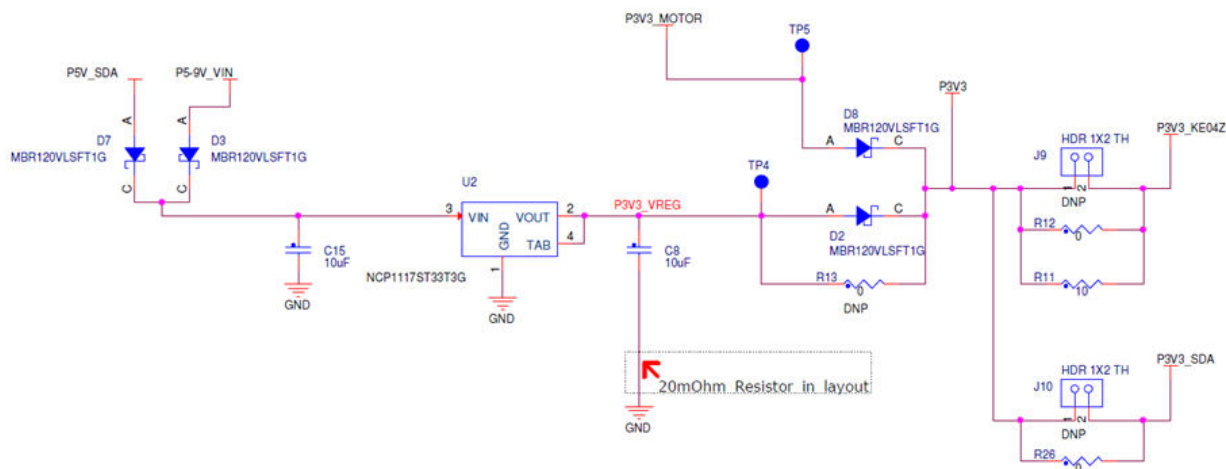

Figure 2. FRDM-KE04Z block diagram

[Table 1](#) provides operational details and requirements for the power supplies.

**Table 1. Power supply requirements**

Supply source	Valid range	OpenSDA operational?	Regulated onboard?
OpenSDA USB (J7)	5 V	>Yes	Yes
VIN pin on I/O header	4.3–9 V	Yes	Yes
3.3V pin on I/O header	1.71–3.6 V	Yes	No
3.3V pin on motor control header	3.3 V	Yes	No

**NOTE**

The OpenSDA circuit is only operational when a USB cable is connected and supplying power to J6. However, the protection circuitry is in place to enable multiple sources to be powered at once.

**Table 2. FRDM-KE04Z power supplies**

Power supply name	Description
P5–9V_VIN	Power supplied from the <b>V<sub>IN</sub> pin of the I/O headers</b> (J4 pin 16).
P5V_SDA	Power supplied from the <b>OpenSDA USB</b> connector (J6).
P3V3_VREG	<b>Regulated 3.3 V supply.</b> Sources power to the P3V3 supply rail through a back drive protection Schottky diode.
P3V3	<b>Main supply rail</b> for the FRDM-KE04Z. Can be sourced from P3V3_VREG, or directly from the I/O headers (J4 pin 8), or from P3V3_MOTOR.
P3V3_KE04Z	<b>KE04Z MCU power supply.</b> Header J9 provides a convenient means for KE04Z energy consumption measurements.
P3V3_SDA	<b>OpenSDA circuit power supply.</b> Header J10 provides a convenient means for K20 energy consumption measurements.
P5V_USB	Nominal <b>5 V supplied to the I/O headers</b> (J4 pin 10). Sourced from P5V_SDA supply through a back drive protection Schottky diode.
P3V3_MOTOR	3.3 V supply from motor control header.

**NOTE**

- J9 and J10 are not populated by default on the production version. The two pins of these headers are shorted together using the 0 Ω resistors R12 and R26 on the PCB. To measure the energy consumption of either KE04Z or OpenSDA MCU, the 0 Ω resistor between these pins must first be cut. A current probe or a shunt resistor and voltage meter can then be applied to measure the energy consumption on these rails. When the MCU current measurement is done complete and no longer required, the 0 Ω resistors can be soldered on again.
- To get ADC accuracy on KE04Z, it is recommended that a 0 Ω resistor R13 be soldered on and ensure there is no power supply from P3V3\_MOTOR and P3V3 sourced from I/O headers.

## 4.2 Serial and Debug Adapter (OpenSDA)

OpenSDA is an open-standard serial and debug adapter. It bridges serial and debug communications between a USB host and an embedded target processor as shown in [Figure 3](#). The hardware circuit is based on a Freescale Kinetis K20 family microcontroller (MCU) with 128 KB of embedded flash and an integrated USB controller. OpenSDA features a mass storage

device (MSD) bootloader, which provides a quick and easy mechanism for loading different OpenSDA applications such as flash programmers, run-control debug interfaces, serial-to-USB converters, and more. Two or more OpenSDA applications can run simultaneously. For example, run-control debug application and serial-to-USB converter runs in parallel to provide a virtual COM communication interface while allowing code debugging via OpenSDA with just a single USB connection. These two applications are provided in a single code package.

For more details, refer to the *OpenSDA User's Guide* available on [freescale.com](http://freescale.com).

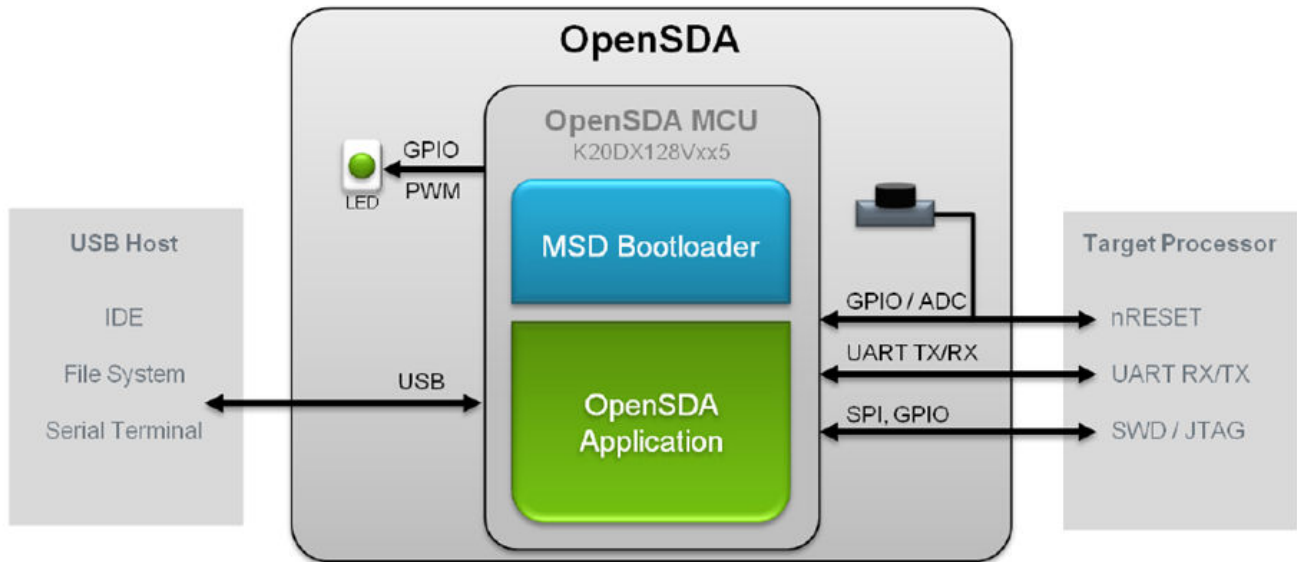

**Figure 3. OpenSDA block diagram**

OpenSDA is managed by a Kinetis K20 MCU built on the ARM Cortex-M4 core. The OpenSDA circuit includes a status LED (D4) and a RESET pushbutton (SW1). The pushbutton asserts the reset signal to the KE04Z target MCU. It can also be used to place the OpenSDA circuit into bootloader mode by holding down the RESET pushbutton while plugging the USB cable to USB connector J6. After the OpenSDA enters bootloader mode, other OpenSDA applications such as the debug application can be programmed.

SPI and GPIO signals provide an interface to the SWD debug port of KE04Z. Additionally, signal connections are available to implement a UART serial channel. The OpenSDA circuit receives power when the USB connector J6 is plugged into a USB host.

### 4.2.1 Debugging interface

Signals with SPI and GPIO capability are used to connect directly to the SWD of KE04Z. These signals are also brought out to a standard 10-pin (0.05”) Cortex debug connector (J7) as shown in [Figure 4](#). It is possible to isolate the KE04Z MCU from the OpenSDA circuit and use J7 to connect to an off-board MCU. To accomplish this, cut the 0 Ω resistor R58. This will disconnect the SWD\_CLK pin to the KE04Z so that it will not interfere with the communications to an off-board MCU connected to J7.

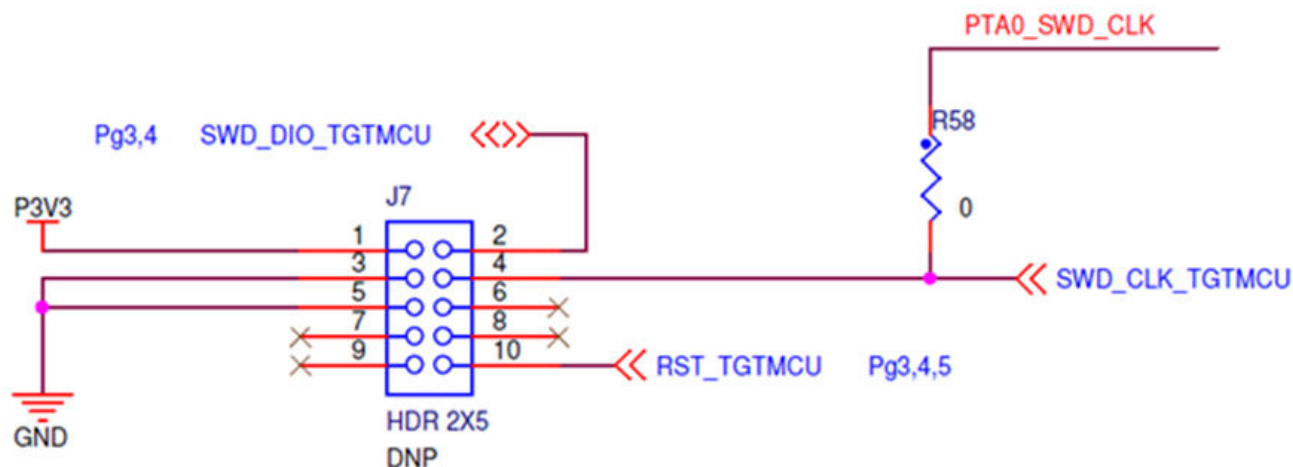

Figure 4. FRDM-KE04Z block diagram

## 4.2.2 Virtual serial port

A serial port connection is available between the OpenSDA MCU and UART0 pin PTB1 (TXD) and PTB0 (RXD) of KE04Z. Freescale provides several default OpenSDA applications, such as the MSD Flash Programmer and the P&E Debug Application which provide a USB communication Device Class (CDC) interface that bridges serial communication between the USB host and its serial interface on KE04Z MCU.

## 4.3 KE04Z microcontroller

### 4.3.1 Clock Source

The Kinetis KE04 microcontrollers feature an on-chip oscillator compatible with two ranges of input crystal or resonator frequencies: 32 kHz (low-frequency mode) and 4–20 MHz (high-frequency mode).

The KE04Z on the FRDM-KE04Z is clocked from a 8 MHz crystal.

#### 4.3.1.1 Serial port

The serial port interface signals used with OpenSDA are UART0 pin PTB1 (TXD) and PTB0 (RXD). These signals are also connected to I/O header J1.

#### 4.3.1.2 Reset

The PTA5/RESET signal on the KE04Z is externally connected to a pushbutton, SW1. The reset button can be used to force an external reset event in the target MCU. It can also be used to force the OpenSDA circuit into bootloader mode when plugging the USB cable to J6. For more details, see [Serial and Debug Adapter \(OpenSDA\)](#) section.

### 4.3.1.3 Debug

The sole debug interface on all Kinetis E series devices is a Serial Wire Debug (SWD) port. The primary controller of this interface on the FRDM-KE04Z is the onboard [OpenSDA](#) circuit. However, a 2x5-pin (0.05”) [Cortex Debug connector](#), J7, provides access to the SWD signals for the KE04Z MCU. The following table shows SWD connector signals description for KE04Z:

**Table 3. ARM JTAG/SWD mini connector description**

Pin	Function	Connection to KE04Z
1	VTref	3.3V system power supply (V_BRD)
2	SWDIO/TMS	PTA4/SWD_DIO
3	GND	GND
4	SWDCLK/TCK	PTA0/SWD_CLK
5	GND	GND
6	SWO/TDO	NC
7	NC	NC
8	TDI	NC
9	NC	NC
10	RESET	PTA5/RESET

## 4.4 Infrared port

One infrared Rx port and one Tx port, as shown in [Figure 5](#), are connected to ACMP0 input pin (ACMP0\_IN1) and UART0 TXD0 pin of KE04Z to demonstrate the capability of UART0 modulated by the Flextimer module for generating infrared signals and use ACMP0 as a filter to receive the SCI data via infrared signal.



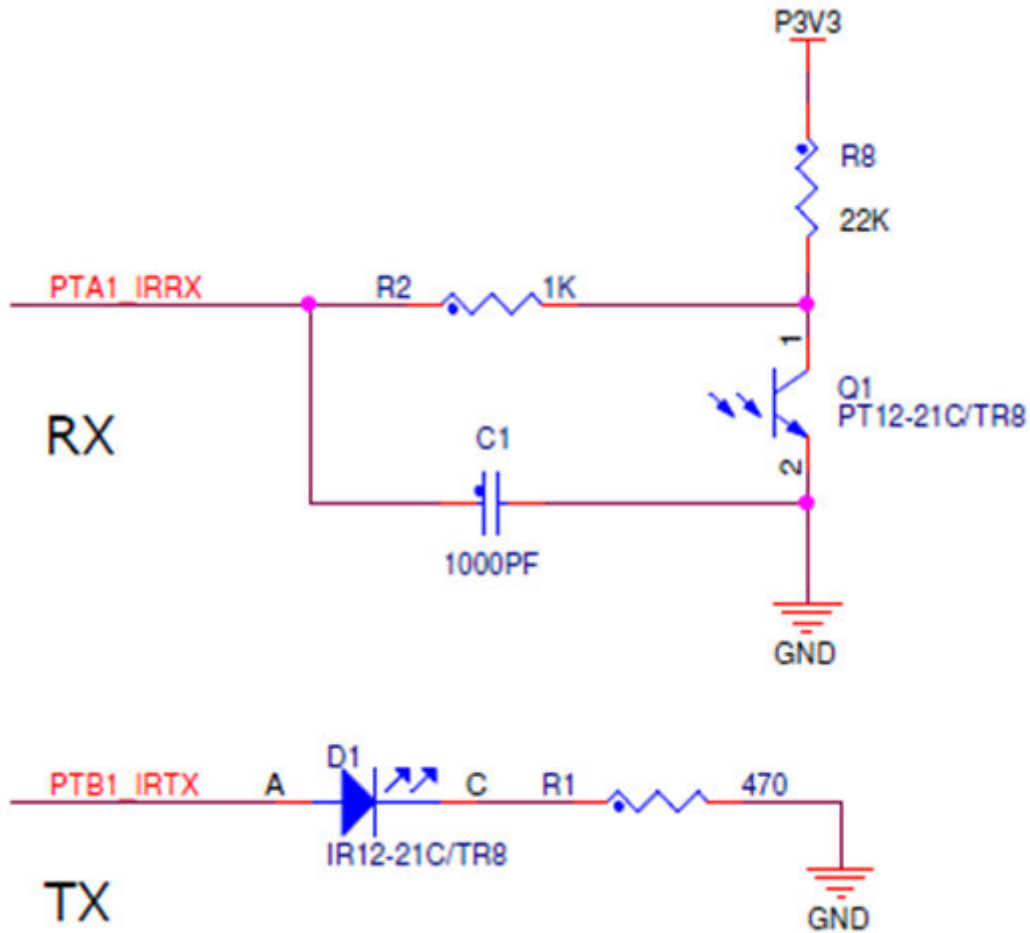

Figure 5. Infrared connection

## 4.5 Capacitive touch slider

Two GPIO pins, functioning as Touch Sense Input (TSI) signals, are connected to capacitive electrodes configured as a touch slider as shown in the following figure:

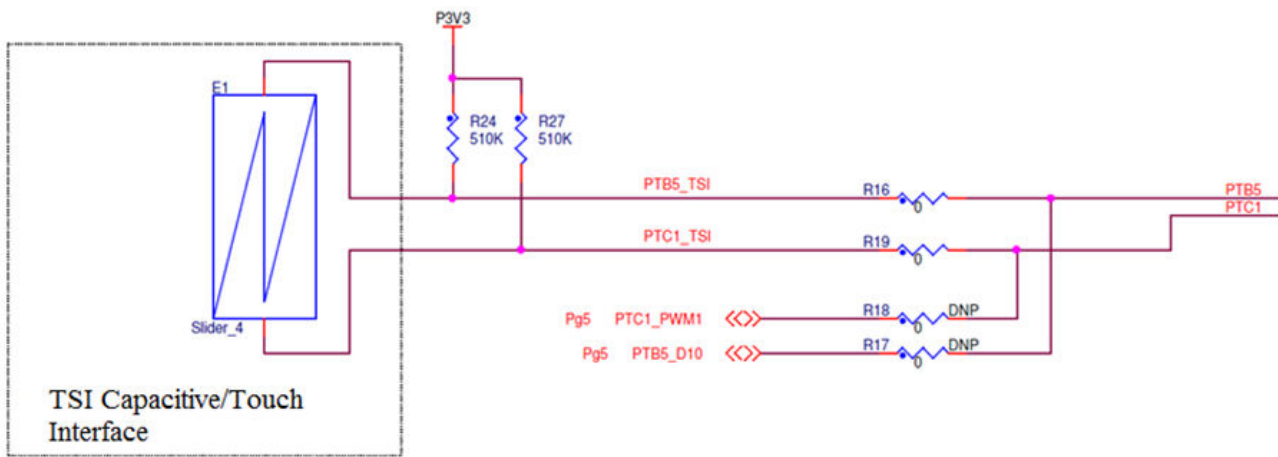

Figure 6. Touch slider connection

## 4.6 Three-axis accelerometer

A Freescale MMA8451Q low-power, and three-axis accelerometer is interfaced through an I<sup>2</sup>C bus and two GPIO signals, as shown in Table 4. By default, the I<sup>2</sup>C address is 0x1D (SA0 pulled high).

Table 4. Accelerometer signal connections

MMA8451Q	KE04Z
SCL	PTA3
SDA	PTA2
INT1	PTC0
INT2	-

The application circuit of MMA8451 is represented as follows:

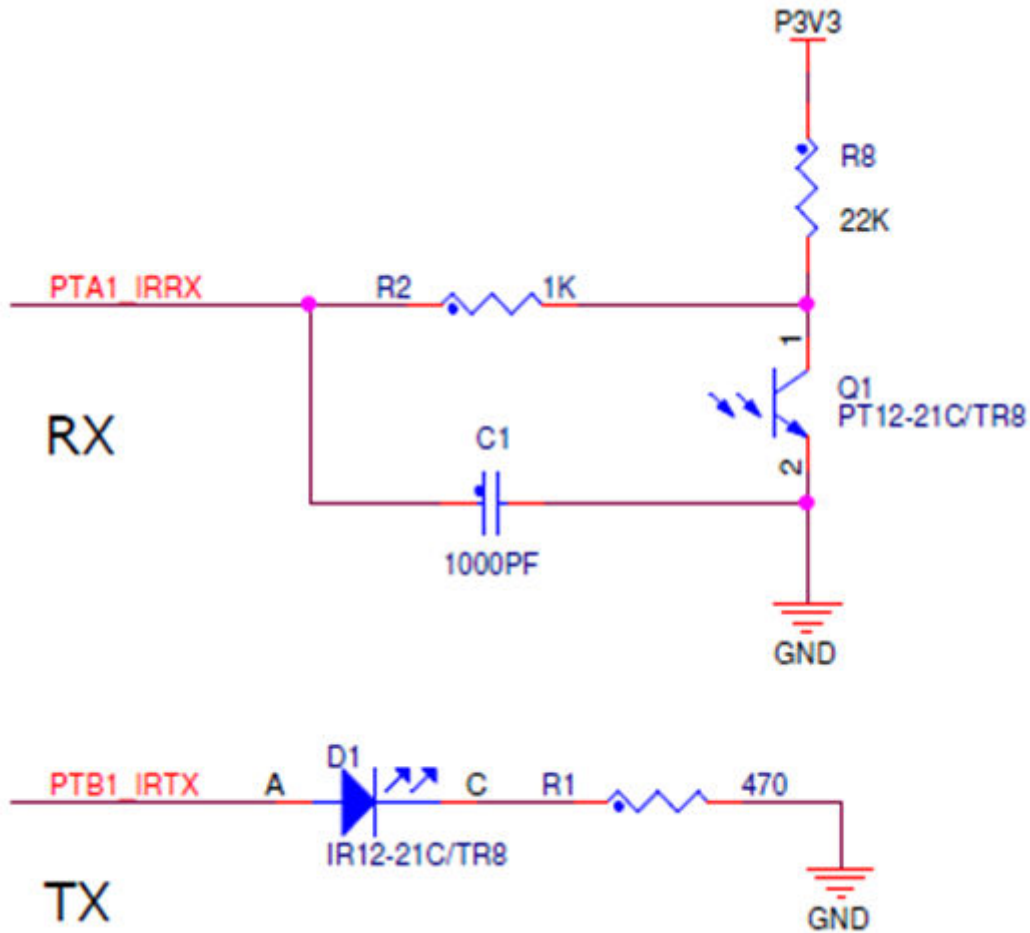

Figure 7. Accelerometer connection

## 4.7 RGB LED

Three PWM-capable KE04Z signals are connected to red, green, and blue LED. The signal connections are shown in [Table 5](#).

Table 5. RGB LED signal connections

RGB LED	KE04Z
Red Cathode	PTC5/FTM2CH3/BUSOUT
Green Cathode	PTC4/FTM2CH2
Blue Cathode	PTB3/FTM0CH0

The following figure represents the RGB LED circuit:

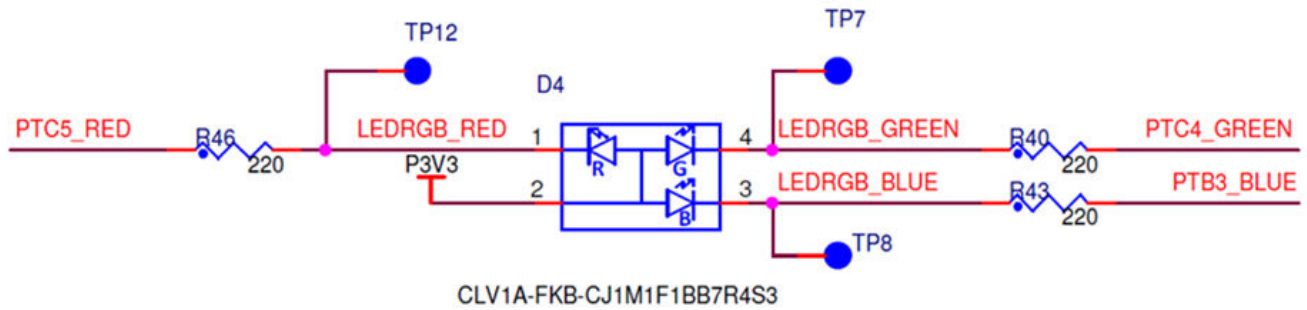

Figure 8. RGB LED connection

## 4.8 Input/Output headers

The MKE04Z8VFK4 microcontroller is packaged in a 24-pin QFN. Some pins are utilized in onboard circuitry, but many are directly connected to one of four I/O headers (J1, J2, J3, and J4). J1 and J2 also function as motor control headers to provide access to a motor control board, such as simple BLDC motor driving board APMOTOR56F8000E.

The following figure provides all the details of input/output headers:

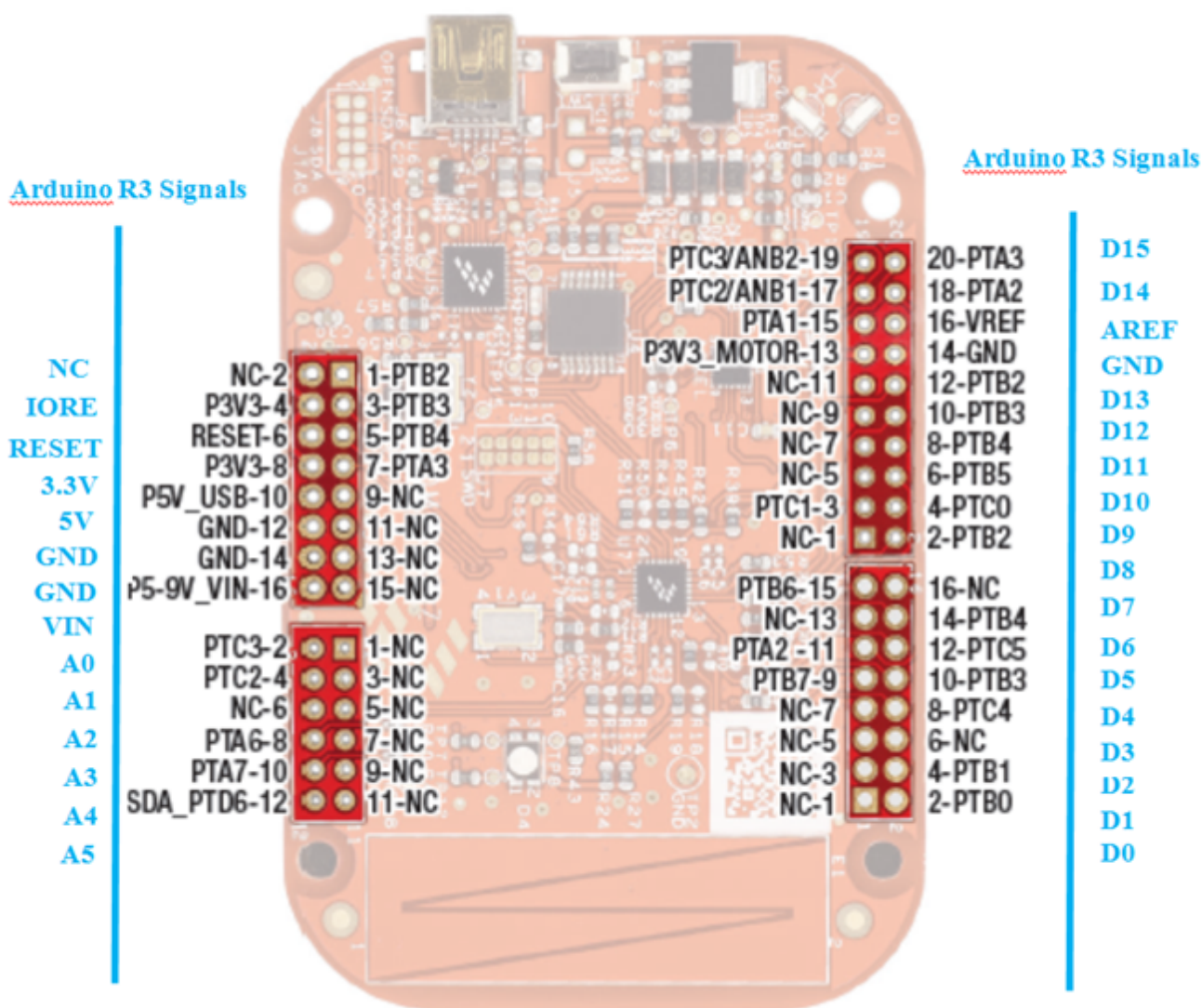

Figure 9. I/O headers

## 4.9 Arduino compatibility

The I/O headers on the FRDM-KE04Z are arranged to enable compatibility with peripheral boards (known as shields) that connect to Arduino and Arduino-compatible microcontroller boards. The pins on the headers share the same mechanical spacing and placement as the I/O headers on the Arduino Uno Revision 3 board design. See [Figure 9](#) for compatible signals.

## 5 References

- *OpenSDA User's Guide* (document OSD AUG), available at [freescale.com](http://freescale.com)
- *KE04 Sub-Family Reference Manual*, available at [freescale.com](http://freescale.com)

## Revision history

- *Arduino Overview*, available at [wikipedia.com](http://wikipedia.com)
- *Arduino Uno*, available at [www.arduino.cc/en/Main/arduinoBoardUno](http://www.arduino.cc/en/Main/arduinoBoardUno)

## 6 Revision history

Table 6. Revision history

Revision number	Date	Substantial changes
0	02/2014	Initial release

**How to Reach Us:**

**Home Page:**

[freescale.com](http://freescale.com)

**Web Support:**

[freescale.com/support](http://freescale.com/support)

Information in this document is provided solely to enable system and software implementers to use Freescale products. There are no express or implied copyright licenses granted hereunder to design or fabricate any integrated circuits based on the information in this document.

Freescale reserves the right to make changes without further notice to any products herein. Freescale makes no warranty, representation, or guarantee regarding the suitability of its products for any particular purpose, nor does Freescale assume any liability arising out of the application or use of any product or circuit, and specifically disclaims any and all liability, including without limitation consequential or incidental damages. "Typical" parameters that may be provided in Freescale data sheets and/or specifications can and do vary in different applications, and actual performance may vary over time. All operating parameters, including "typicals," must be validated for each customer application by customer's technical experts. Freescale does not convey any license under its patent rights nor the rights of others. Freescale sells products pursuant to standard terms and conditions of sale, which can be found at the following address: [freescale.com/SalesTermsandConditions](http://freescale.com/SalesTermsandConditions).

Freescale, the Freescale logo, Altivec, C-5, CodeTest, CodeWarrior, ColdFire, ColdFire+, C-Ware, Energy Efficient Solutions logo, Kinetis, mobileGT, PowerQUICC, Processor Expert, QorIQ, Qorivva, StarCore, Symphony, and VortiQa are trademarks of Freescale Semiconductor, Inc., Reg. U.S. Pat. & Tm. Off. Airfast, BeeKit, BeeStack, CoreNet, Flexis, Layerscape, MagniV, MXC, Platform in a Package, QorIQ Qonverge, QUICC Engine, Ready Play, SafeAssure, SafeAssure logo, SMARTMOS, Tower, TurboLink, Vybrid, and Xtrinsic are trademarks of Freescale Semiconductor, Inc. All other product or service names are the property of their respective owners.

© 2014 Freescale Semiconductor, Inc.

Document Number FRDMKE04ZUM  
Revision 0, 02/2014



**How to Reach Us:**

**Home Page:**  
[freescale.com](http://freescale.com)

**Web Support:**  
[freescale.com/support](http://freescale.com/support)

Information in this document is provided solely to enable system and software implementers to use Freescale products. There are no express or implied copyright licenses granted hereunder to design or fabricate any integrated circuits based on the information in this document.

Freescale reserves the right to make changes without further notice to any products herein. Freescale makes no warranty, representation, or guarantee regarding the suitability of its products for any particular purpose, nor does Freescale assume any liability arising out of the application or use of any product or circuit, and specifically disclaims any and all liability, including without limitation consequential or incidental damages. "Typical" parameters that may be provided in Freescale data sheets and/or specifications can and do vary in different applications, and actual performance may vary over time. All operating parameters, including "typicals," must be validated for each customer application by customer's technical experts. Freescale does not convey any license under its patent rights nor the rights of others. Freescale sells products pursuant to standard terms and conditions of sale, which can be found at the following address: [freescale.com/SalesTermsandConditions](http://freescale.com/SalesTermsandConditions).

Freescale, the Freescale logo, and Kinetis are trademarks of Freescale Semiconductor, Inc., Reg. U.S. Pat. & Tm. Off. All other product or service names are the property of their respective owners. ARM and Cortex are registered trademarks of ARM Limited (or its subsidiaries) in the EU and/or elsewhere. All rights reserved.

© 2014 Freescale Semiconductor, Inc.



Document Number: FRDMKE04ZUM  
Rev. 0  
02/2014

