

AME5142/5142A/5142B

General Description

The AME5142/5142A/5142B is a Boost DC/DC converter specifically designed to drive white LEDs with a constant current. The device can drive 1 to 6 LEDs in series or multiple strings from a Li-Ion cell. Series connection of the LEDs provides identical LED currents resulting in uniform brightness and eliminating the need for ballast resistors. The AME5142/5142A/5142B switches at 1.2MHz, allowing the use of tiny external components. The input and output capacitor can be as small as 1 μ F (or 4.7 μ F), saving space and cost versus alternative solutions. A low feedback voltage minimizes power loss in the current setting resistor for better efficiency. The AME5142/5142A/5142B is available in SOT-26/TSOT-26 & SOT-25/TSOT-25 packages.

The only difference between AME5142, AME5142A and AME5142B is feedback trip point. The AME5142 is 0.15V and AME5142A/5142B is 0.104V.

Features

- 1.2MHz Fixed Switching Frequency
- 28V Over Voltage Protection
- Over Temperature Protection
- Under Voltage Lockout Protection
- Internal Soft Start
- 30V Internal Switch
- Drives Up to 6 LEDs from a 2.7V Supply at 20mA
- Only small external Capacitors and Inductor required
- Cycle-by-Cycle Current Limiting
- Up to 88% Efficiency
- Meet RoHS Standards

Applications

- LCD Bias
- Hand-held Computers
- Battery Backup
- Digital Cameras
- Personal Navigation Device
- Digital Picture Frame
- Smart Phone

Typical Application

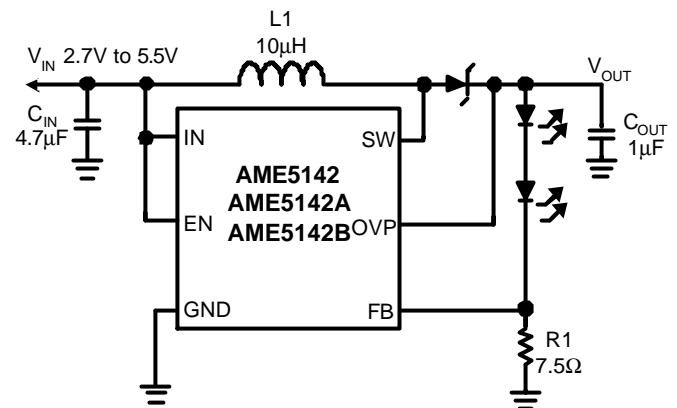

Figure 1: Circuit For Driving 2 White LEDs

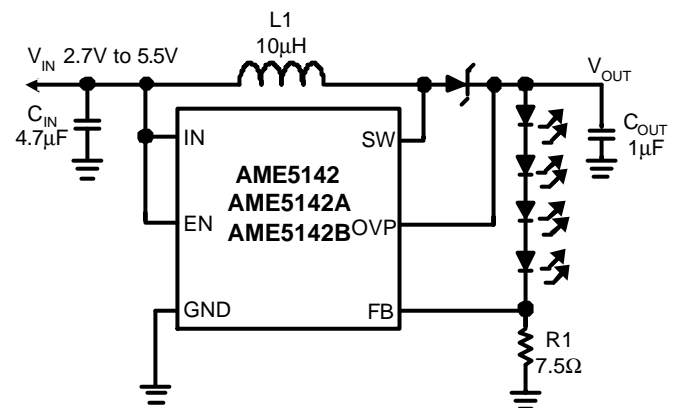

Figure 2: Circuit For Driving 4 White LEDs

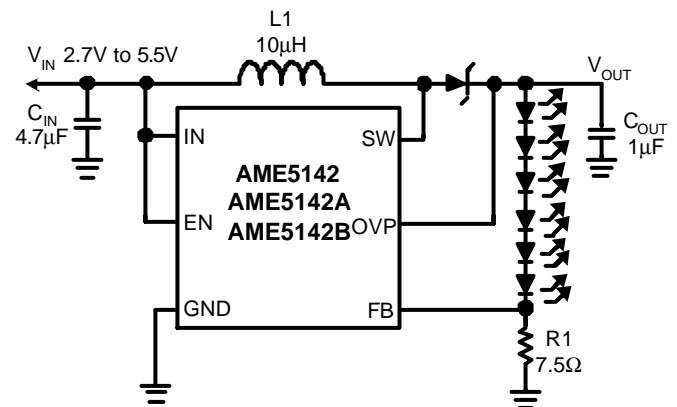
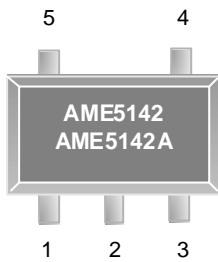

Figure 3: Circuit For Driving 6 White LEDs

AME5142/5142A/5142B

■ Pin Configuration

**SOT-25/TSOT-25
Top View**



**AME5142AEEV
AME5142AAEEV**

1. SW
2. GND
3. FB
4. EN
5. IN

**SOT-26/TSOT-26 (Recommend)
Top View**

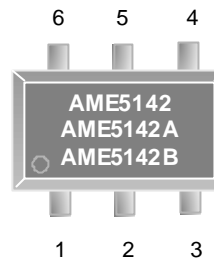

**AME5142AEEY
AME5142AAEEY
AME5142BAEEY**

1. SW
2. GND
3. FB
4. EN
5. OVP
6. IN

(Recommend)

**Die Attach:
Conductive Epoxy**

**Die Attach:
Conductive Epoxy**

■ Pin Description

AME5142AEEV/AME5142AAEEV

Pin Number	Pin Name	Pin Description
1	SW	Power Switch input. This is the drain of the internal NMOS power switch. Minimize the metal trace area connected to this pin to minimize EMI.
2	GND	Ground. Tie directly to ground plane.
3	FB	Output voltage feedback input. Connect the ground of the feedback network to an AGND (Analog Ground) plane which should be tied directly to the GND pin.
4	EN	Enable control input, active high. The enable pin is an active high control. Tie this pin above 1.5V to enable the device. Tie this pin below 0.4V to turn off the device.
5	IN	Analog and Power input. Input Supply Pin. Bypass this pin with a capacitor as close to the device as possible.



■ Pin Description

AME5142AEEY/AME5142AAEEY/AME5142BAEEY (Recommend)

Pin Number	Pin Name	Pin Description
1	SW	Power Switch input. This is the drain of the internal NMOS power switch. Minimize the metal trace area connected to this pin to minimize EMI.
2	GND	Ground. Tie directly to ground plane.
3	FB	Output voltage feedback input. Connect the ground of the feedback network to an AGND(Analog Ground) plane which should be tied directly to the GND pin.
4	EN	Enable control input, active high. The enable pin is an active high control. Tie this pin above 1.5V to enable the device. Tie this pin below 0.4V to turn off the device.
5	OVP	Over Voltage Protection.
6	IN	Analog and Power input. Input Supply Pin. Bypass this pin with a capacitor as close to the device as possible.



AME5142/5142A/5142B

Ordering Information

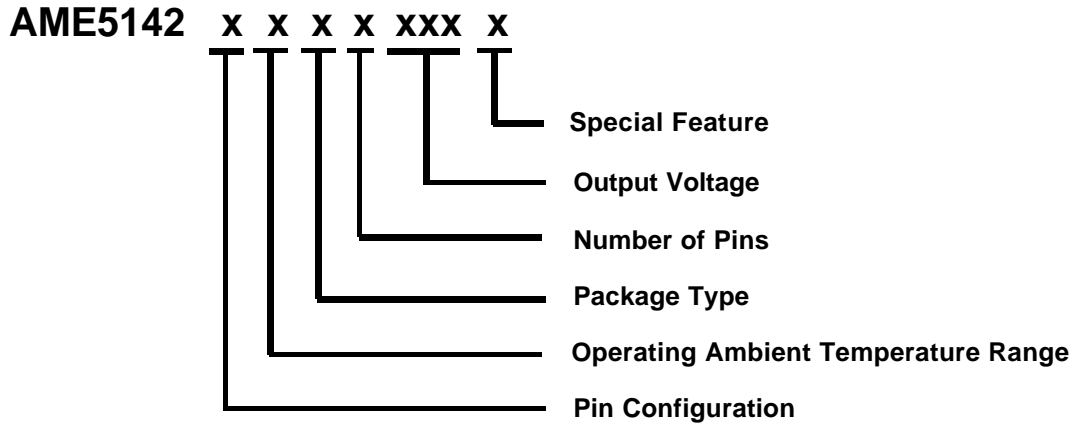

Pin Configuration	Operating Ambient Temperature Range	Package Type	Number of Pins	Output Voltage	Special Feature
A 1. SW (SOT-25) 2. GND (TSOT-25) 3. FB 4. EN 5. IN A 1. SW (SOT-26) 2. GND (TSOT-26) 3. FB 4. EN 5. OVP 6. IN	E: -40°C to +85°C	E: SOT-2X	V: 5 Y: 6	ADJ: Adjustable	Y: Lead free & Low profile Z: Lead free

AME5142/5142A/5142B

■ Ordering Information

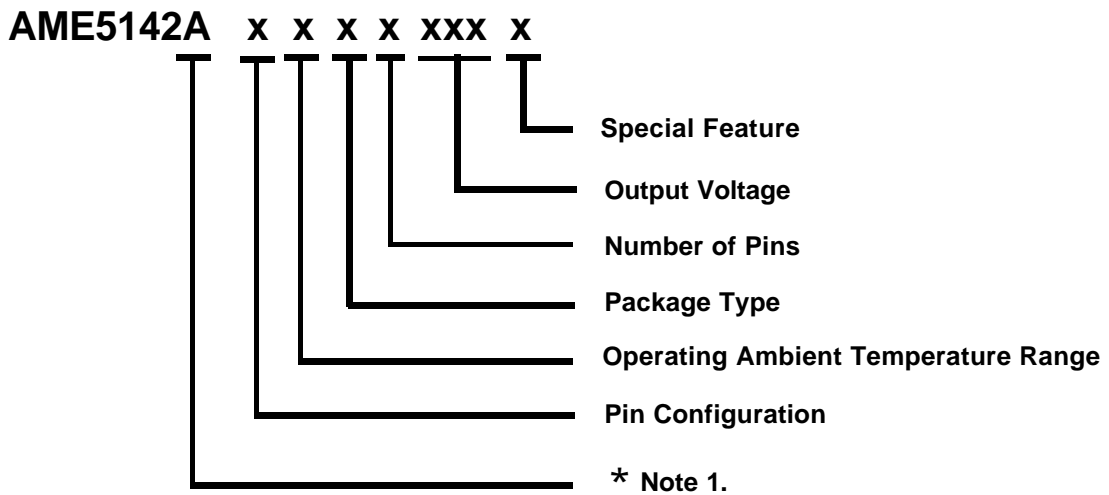

* Note 1. AME5142 feedback trip point is 0.15V. AME5142A feedback trip point is 0.104V.

Pin Configuration	Operating Ambient Temperature Range	Package Type	Number of Pins	Output Voltage	Special Feature
A 1. SW (SOT-25) 2. GND (TSOT-25) 3. FB 4. EN 5. IN	E: -40°C to +85°C	E: SOT-2X	V: 5 Y: 6	ADJ: Adjustable	Y: Lead free & Low profile Z: Lead free
A 1. SW (SOT-26) 2. GND (TSOT-26) 3. FB 4. EN 5. OVP 6. IN					



AME5142/5142A/5142B

Ordering Information

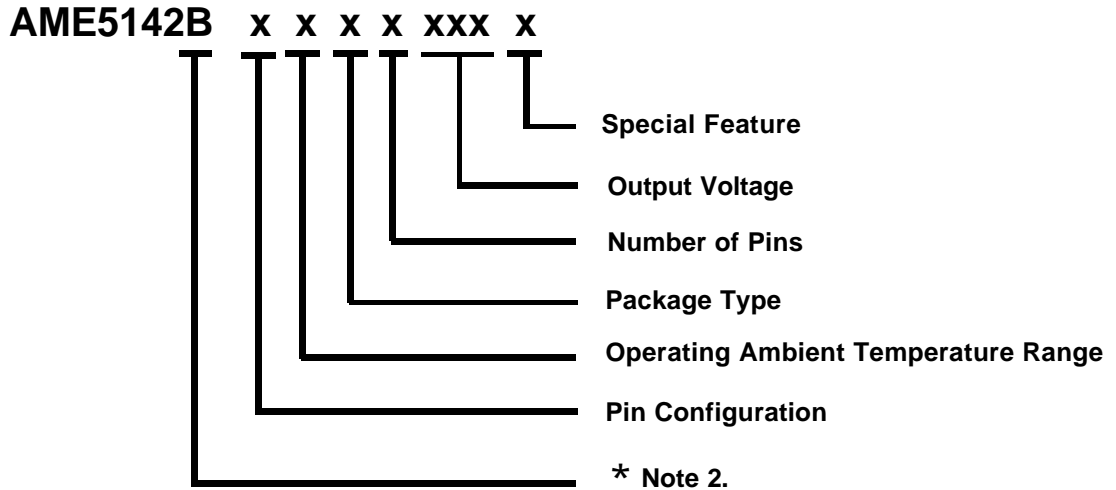

* Note 2. AME5142 feedback trip point is 0.15V. AME5142A and AME5142B feedback trip point is 0.104V. The only difference between AME5142A and AME5142B is the behavior of OVP. Please refer to Output Over-Voltage Protection.

Pin Configuration	Operating Ambient Temperature Range	Package Type	Number of Pins	Output Voltage	Special Feature
A (SOT-26) 1. SW 2. GND 3. FB 4. EN 5. OVP 6. IN	E: -40°C to +85°C	E: SOT-2X	Y: 6	ADJ: Adjustable	Z: Lead free



High Efficiency 6 White LED Driver With Open LED Protection

AME5142/5142A/5142B

■ Ordering Information

Part Number	Marking*	Output Voltage	Package	Operating Ambient Temperature Range
AME5142AEEYADJZ	BJGww	ADJ	SOT-26	-40°C to +85°C
AME5142AEEYADJY	BJGww	ADJ	TSOT-26	-40°C to +85°C
AME5142AEEVADJZ	BJHww	ADJ	SOT-25	-40°C to +85°C
AME5142AEEVADJY	BJHww	ADJ	TSOT-25	-40°C to +85°C
AME5142AAEEYADJZ	BVKww	ADJ	SOT-26	-40°C to +85°C
AME5142AAEEYADJY	BVKww	ADJ	TSOT-26	-40°C to +85°C
AME5142BAEEYADJZ	BYPww	ADJ	SOT-26	-40°C to +85°C
AME5142BAEEYADJY	BYPww	ADJ	TSOT-26	-40°C to +85°C
AME5142AAEEVADJZ	BVLww	ADJ	SOT-25	-40°C to +85°C
AME5142AAEEVADJY	BVLww	ADJ	TSOT-25	-40°C to +85°C

Note: ww represents the date code and pls refer to Date Code Rule page on Package Dimension.

* A line on top of the first letter represents lead free plating such as BJGww.

Please consult AME sales office or authorized Rep./Distributor for the availability of package type.

AME5142/5142A/5142B

■ Absolute Maximum Ratings

Parameter	Symbol	Maximum	Unit
Input Supply Voltage	V_{IN}	6	V
EN, FB Voltages	V_{EN}, V_{FB}	V_{IN}	V
SW, OVP Voltage	V_{SW}, V_{OVP}	30	V
ESD Classification		B*	

Caution: Stress above the listed in absolute maximum ratings may cause permanent damage to the device.

* HBM B: 2000V ~ 3999V

■ Recommended Operating Conditions

Parameter	Symbol	Rating	Unit
Ambient Temperature Range	T_A	-40 to +85	°C
Junction Temperature Range	T_J	-40 to +125	
Storage Temperature Range	T_{STG}	-65 to +150	

■ Thermal Information

Parameter	Package	Die Attach	Symbol	Maximum	Unit
Thermal Resistance* (Junction to Case)	SOT-25 TSOT-25 SOT-26 TSOT-26	Conductive Epoxy	θ_{JC}	81	°C / W
Thermal Resistance (Junction to Ambient)			θ_{JA}	260	
Internal Power Dissipation			P_D	400	mW
Solder Iron (10Sec)**				350	°C

* Measure θ_{JC} on center of molding compound if IC has no tab.

** MIL-STD-202G 210F

AME5142/5142A/5142B

■ Electrical Specifications

$V_{IN} = 4.2V$, $EN = V_{IN}$, $T_A = 25^{\circ}C$, Unless otherwise noted.

Parameter	Symbol	Test Condition	Min	Typ	Max	Units
Input Voltage	V_{IN}		2.7		5.5	V
Quiescent Current	I_Q	Switching, $V_{FB} = 0V$		0.85	1	mA
		Not Switching, $V_{FB} = 0.2V$		180	250	μA
Feedback Trip Point (AME5142)	V_{FB}		0.137	0.15	0.163	V
Feedback Trip Point (AME5142A/5142B)	V_{FB}		0.094	0.104	0.114	V
FB Pin Bias Current	I_{FB}	$V_{FB} = 0.2V$		0.1	1	μA
Switch Current Limit	I_{CL}		650	850	1000	mA
Switch On-Resistance	R_{DSON}	$I_{SW} = 100mA$, $V_{FB} = 0.2V$		0.7	1.4	Ω
SW Leakage Current	I_{SW}	$V_{SW} = 20V$		1	10	μA
Switch frequency	f_{SW}	$V_{FB} = 0.1V$	0.9	1.2	1.5	MHz
Maximum Duty Cycle	Dmax	$V_{FB} = 0V$	88	92		%
Shutdown Supply Current	I_{SD}	$V_{EN} = 0V$		0.01	1	μA
Over Temperature Protection	OTP	Shutdown, temperature increasing		160		$^{\circ}C$
	T_{RS}	Restore, temperature decreasing		140		
Over Voltage Protection (AME5142)	OVP	Rising edge	24	26	28	V
Over Voltage Protection (AME5142A/5142B)	OVP	Rising edge	26	28	30	
Input Undervoltage Lockout	UVP	V_{IN} rising or falling	2.35	2.5	2.65	V
EN Input Low	V_{EL}				0.4	V
EN Input High	V_{EH}		1.5			
EN Input Current	I_{EN}	$EN = GND$ or V_{IN}		0.1	2	μA

■ Detailed Description

The AME5142/5142A/5142B is a constant frequency step-up converter with an internal switch. The operations of AME5142/5142A/5142B can be understood from block diagram clearly figure.2. The oscillator triggers the SET input of SR latch to turn on the power switch MS at the start of each cycle. A current sense voltage sum with a stabilizing ramp is connected to the positive terminal of the PWM comparator. When this voltage exceeds the output voltage of the error amplifier, the SR latch is reset to turn off the power switch till next cycle starts. The output voltage of the error amplifier is amplified from the difference between the reference voltage 0.15V and the feedback voltage. In this manner, if the error amplifiers voltage increases, more current is delivered to the output; if it decreases, less current is delivered. A 28V Zener diode connects from OVP pin to FB pin internally to provide an optional protection function which prevents SW pin from over-voltage damage. Especially when the case of the feedback loop broken due to component wear-out or improper connection occurs.

Current Limit Protection

The AME5142/5142A/5142B has current limiting protection to prevent excessive stress on itself and external components during overload conditions. The internal current limit comparator will disable the NMOS power device at a typical switch peak current limit of 850mA.

Output Over-Voltage Protection

The AME5142/5142A/5142B contains dedicated circuitry for monitoring the output voltage. In the event that the primary LED network is disconnected the output will increase and be limited to 28V (TYP), which will turn the NMOS off when the output voltage is at 28V (max.) until the output voltage reach 28V (TYP.) or lower. The 28V limit allows the use of 28V 1μF ceramic output capacitors creating an overall small solution for white LED applications. If the output ever exceeds OVP, the AME5142B will shut down. AME5142B will not switch again until the power is recycled. If the output exceeds OVP, the OVP of AME5142/5142A is to clamp the output voltage to 28V typically.

Under Voltage Protection

The AME5142/5142A/5142B has an UVP comparator to turn the NMOS power device off in case the input voltage or battery voltage is too low preventing an on state of the power device conducting large amounts of current.

■ Application Information

Inductor Selection

The recommended value of inductor for AME5142/5142A/5142B applications is 10μH. Small size and better efficiency are the major concerns for portable device, such as AME5142/5142A/5142B used for dual panel mobile phone. The inductor should have low DCR for better efficiency. To avoid inductor saturation, current rating should be at least 1A. The input range is 2.7V to 5.5V.

Capacitor Selection

4.7μF input capacitor can reduce input ripple. For better voltage stability, to increase the input capacitor value or using LC filter is feasible, especially in the Li-ion battery application. 1μF output capacitor is sufficient to reduce output voltage ripple. For better voltage filtering, ceramic capacitors with low ESR are recommended. X5R and X7R types are suitable because of their wider voltage and temperature ranges.

Diode Selection

Schottky diode is a good choice for AME5142/5142A/5142B because of its lower forward voltage drop and faster reverse recovery. Using schottky diode can get better efficiency. The high speed rectification is also a good characteristic of schottky diode for high switching frequency. Current rating of the diode must meet the root mean square of the peak current and output average current multiplication.

Duty Cycle

The maximum duty cycle of the switching regulator determines the maximum boost ratio of output-to-input voltage that the converter can attain in mode of operation. The duty cycle for a given boost application is defined as: This applies for continuous mode operation.

$$D = \frac{V_{OUT} + V_{DIODE} - V_{IN}}{V_{OUT} + V_{DIODE} - V_{SW}}$$

Calculating Load Current

The load current is related to the average inductor current by the relation:

$$I_{LOAD} = I_{IND} (AVG) \times (1 - D)$$

Where "D" is the duty cycle of the application. The switch current can be found by:

$$I_{SW} = I_{IND} (AVG) + 1/2 (I_{RIPPLE})$$

Inductor ripple current is dependent on inductance, duty cycle, input voltage and frequency:

$$I_{RIPPLE} = D \times (V_{IN} - V_{SW}) / (f \times L)$$

Combining all terms, we can develop an expression which allows the maximum available load current to be calculated:

$$I_{LOAD} = (1 - D) \times (I_{CL} (max) - \frac{D (V_{IN} - V_{SW})}{2fL})$$

Thermal Considerations

At higher duty cycles, the increased ON time of the FET means the maximum output current will be determined by power dissipation within the AME5142/5142A/5142B switch. The switch power dissipation from ON-state conduction is calculated by:

$$P_{(SW)} = D \times I_{IND(AVE)2} \times R_{DS(ON)}$$

There will be some switching losses as well, so some derating needs to be applied when calculating IC power dissipation.

Shutdown Pin Operation

The device is turned off by pulling the shutdown pin low. If this function is not going to be used, the pin should be tied directly to V_{IN} . If the SHDN function will be needed, a pull-up resistor must be used to V_{IN} (approximately 50k-100k recommended). The EN pin must not be left unterminated.

AME5142/5142A/5142B

Evaluation Board Schematic

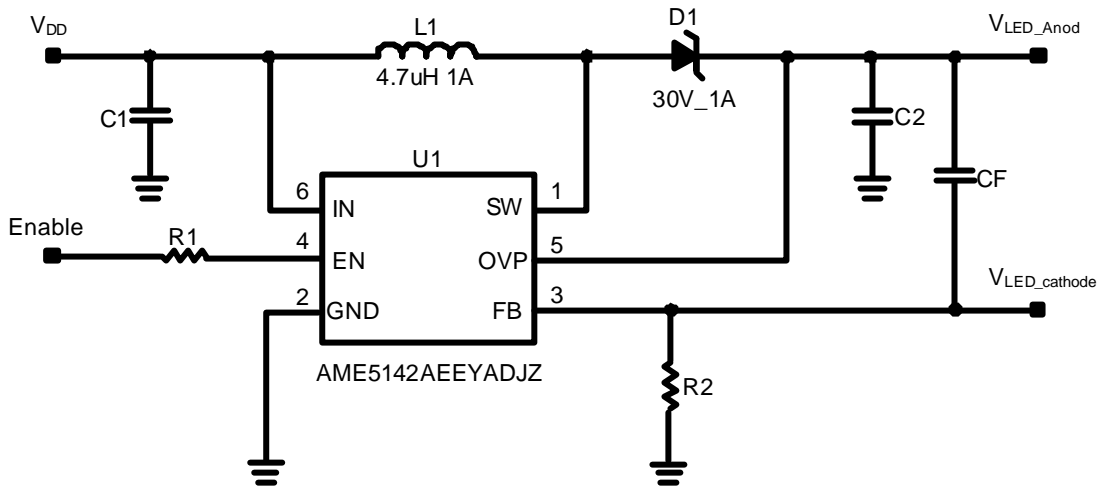

Bill Of Materials

Location	Value	Description	Part Num.	Manufacture	Package
C1	6.3V/4.7uF	Ceramic Capacitor	C1608Y5V0J475ZT	TDK	1608
C7	25V/1uF	Ceramic Capacitor	C2012X7R1E105KT	TDK	2012
R1	51KΩ	Chip Resistor	FCR05-F-T-5102	PDC	805
R5	7.5Ω	Chip Resistor	FCR05-F-T-0750	PDC	805
R3	16.9KΩ	Chip Resistor	FCR05-F-T-1692	PDC	805
L1	4.7uH	Inductor	CDRH3D14/HP-4R7	Sumida	
D1	30V/1A	Schottky Rectifier	B130	Any	SMA



AME5142/5142A/5142B

High Efficiency 6 White LED Driver With Open LED Protection

Operating Instructions

1. Connect VDD to the power source's positive output.
2. Connect GND to supply ground.
3. Applying a logic signal to EN pin will enable the AME5142. Logic high ($V_{EN} > 1.5V$) turns on AME5142, logic low puts it into low current shutdown mode.

Application Information Setting Output Current

The regulated output current is set with an external resistor divider (R5 in Figure 1.) from the output to the V_{FB} pin and is determined by:

$$I_{OUT} = \frac{V_{FB}}{R_5}$$

To prevent stray capacitance and noises, locate resistors R5 close to AME5142.
The external resistor sets the output current table as below :

I_{OUT}	R5
20mA	7.5Ω
40mA	3.75Ω
60mA	2.5Ω
80mA	1.875Ω

AME5142/5142A/5142B

Board Layout Consideration

High frequency switching regulators require very careful layout of components in order to get stable operation and low noise. A good PCB layout could make AME5142 work its best performance.

PCB Layout Example

The PCB layout example of AME5142 for six strings of LEDs to be driven in one parallel application. The placements is suitable and smooth, and follows the layout guide lines.

1. Use a ground plane under the switching regulator to minimize inter-plane coupling.
2. Using 20mil wide track for GND (as wide as possible), and all GND nodes are as close as possible.
3. The SW node, schottky diode and output capacitor C2 signal path should be kept extremely short.
4. The feedback components R1,R2 and CF must be kept close to the FB pin of U1 to prevent noise injection on the FB pin trace and keeping faraway from SW node.

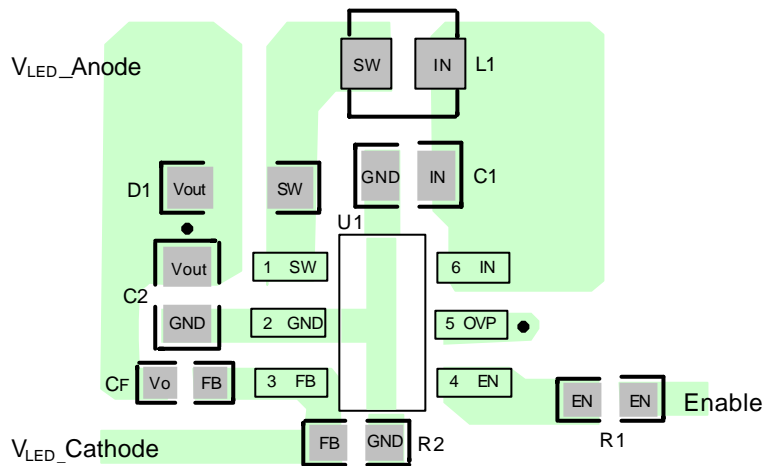

AME5142/5142A/5142B

Dimming Control

A. Using a PWM Signal to EN Pin

For controlling the LED brightness, the AME5142/5142A/5142B can perform the dimming control by applying a PWM signal to EN pin.

The average LED current is proportional to the PWM signal duty cycle. The magnitude of the PWM signal should be higher than the maximum enable voltage of EN pin, in order to let the dimming control perform correctly.

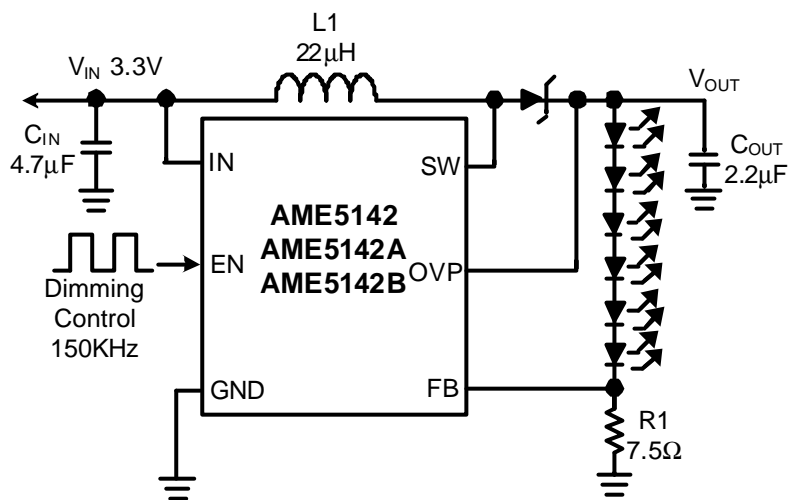
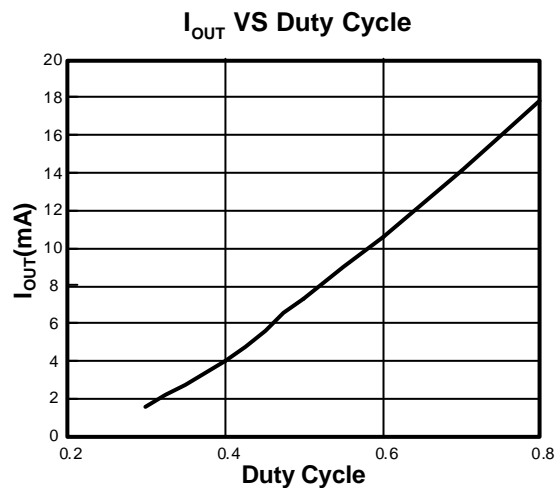
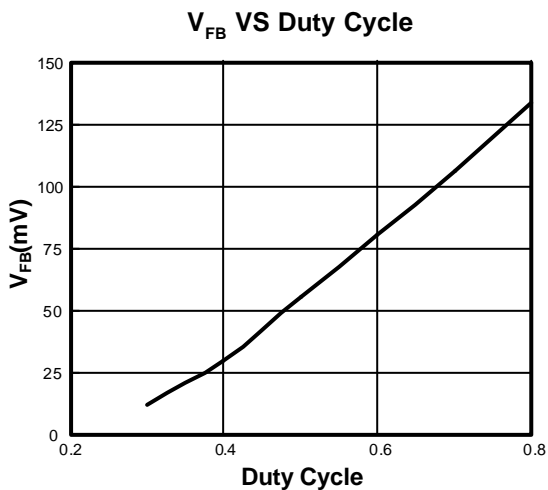

Figure 5. PWM Dimming Control Using the EN Pin



AME5142/5142A/5142B

B. Using a DC Voltage

Using a variable DC voltage to adjust the brightness is a popular method in some applications. The dimming control using a DC voltage circuit is shown in Figure 6. According to the Superposition Theorem, as the DC voltage increases, the voltage contributed to V_{FB} increases and the voltage drop on R2 decreases, i.e. the LED current decreases. For example, if the V_{DC} range is from 0V to 2.8V, the selection of resistors in Figure 6 sets dimming control of LED current from 20mA to 0mA.

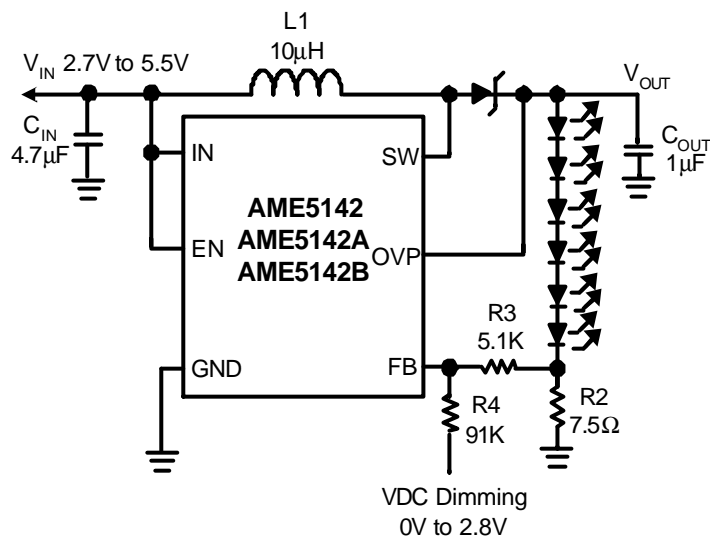
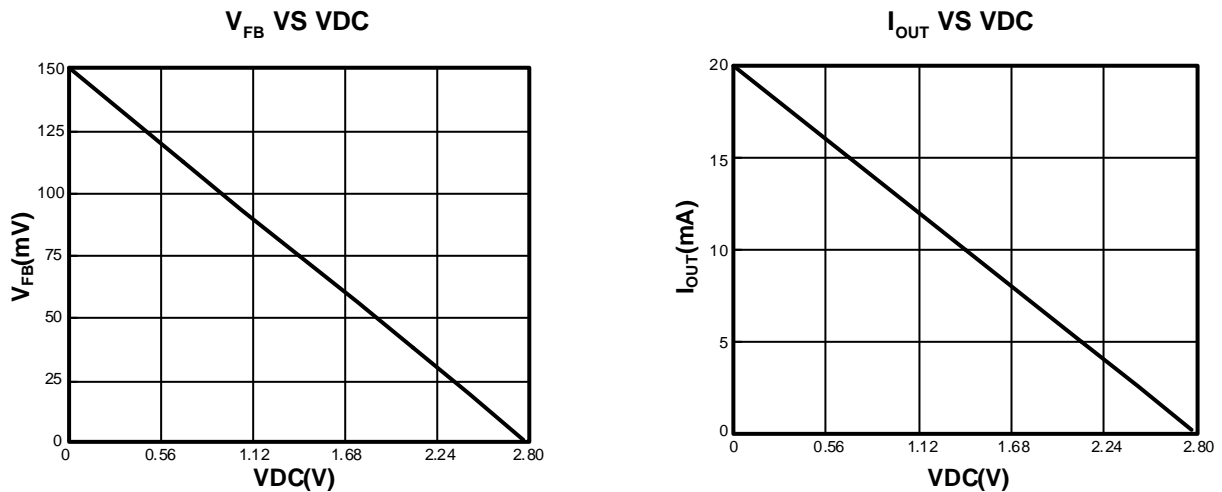

Figure 6. Dimming Control Using a DC Voltage



C. Using a Filtered PWM Signal

The filtered PWM signal can be considered as an adjustable DC voltage. It can be used to replace the variable DC voltage source in dimming control. The circuit is shown in Figure 7.

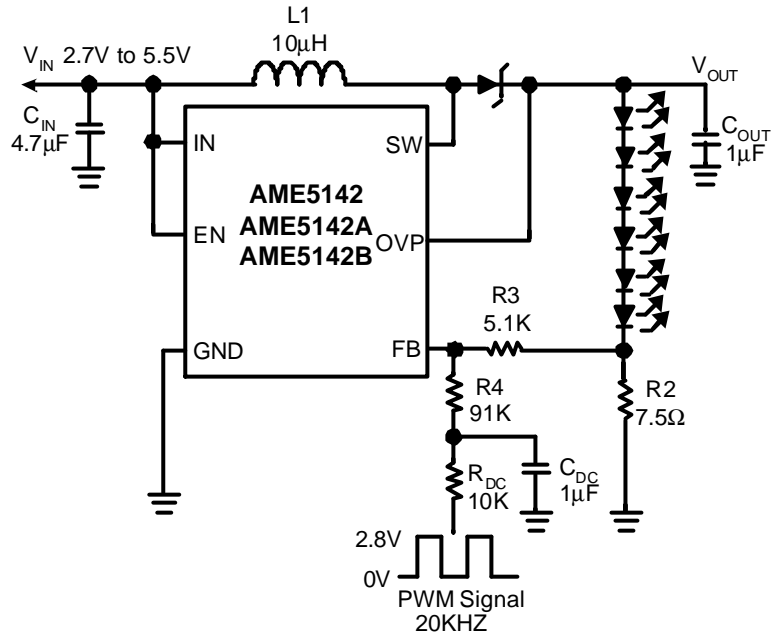
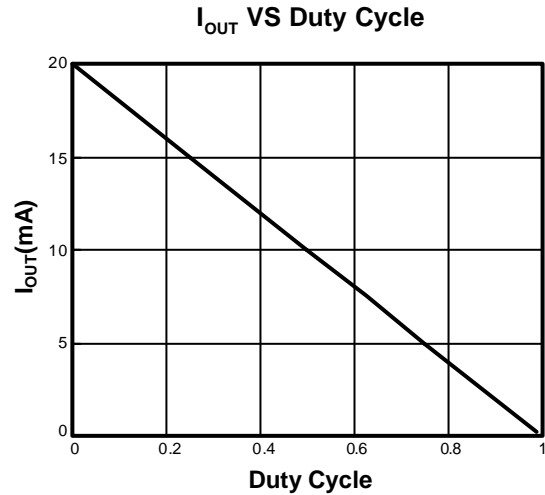
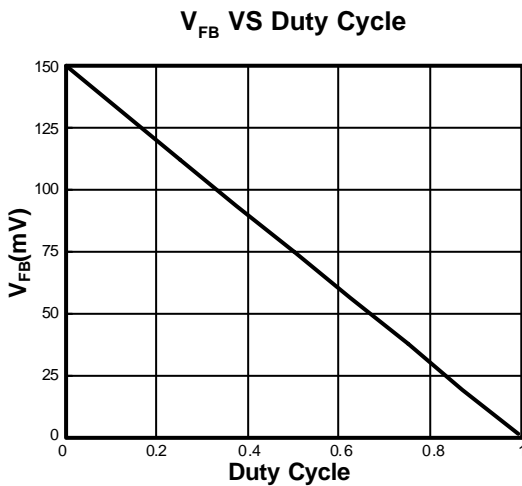

Figure 7. Dimming Control Using a Filtered PWM Signal



AME5142/5142A/5142B

■ Typical Operating Characteristics

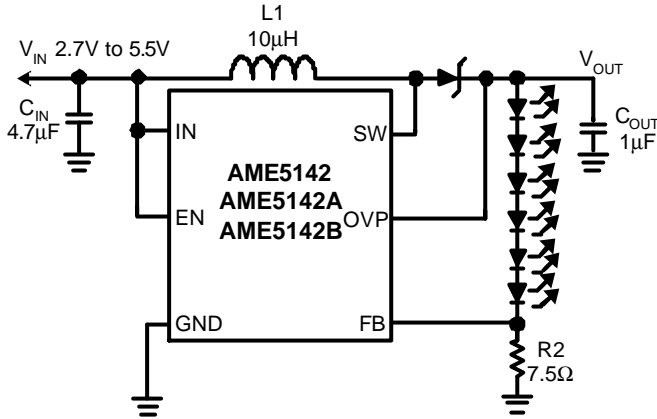

Figure 8: Circuit For Driving 6 White LEDs

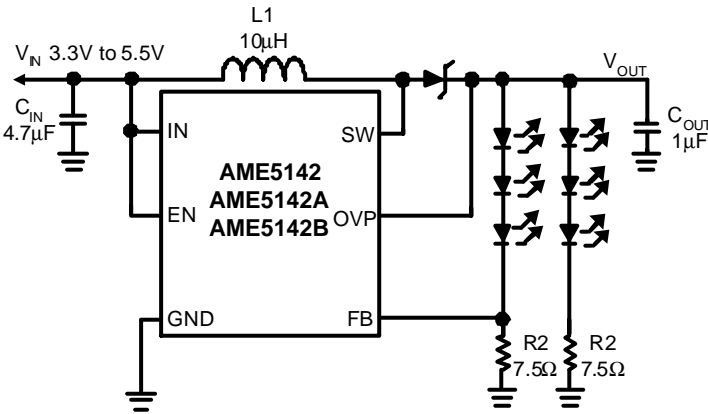
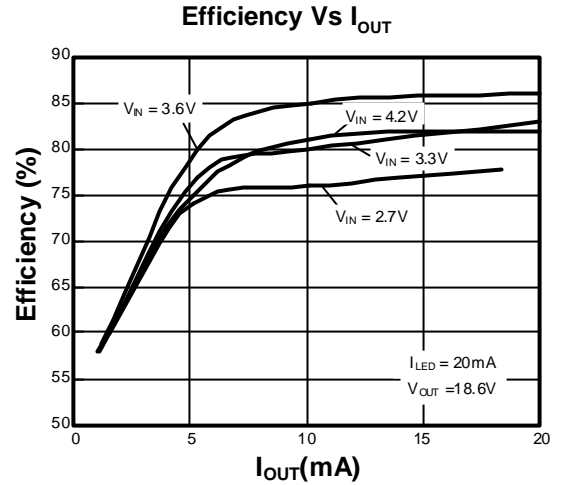

Figure 9: Circuit For Driving 2 Strings of 3 White LEDs

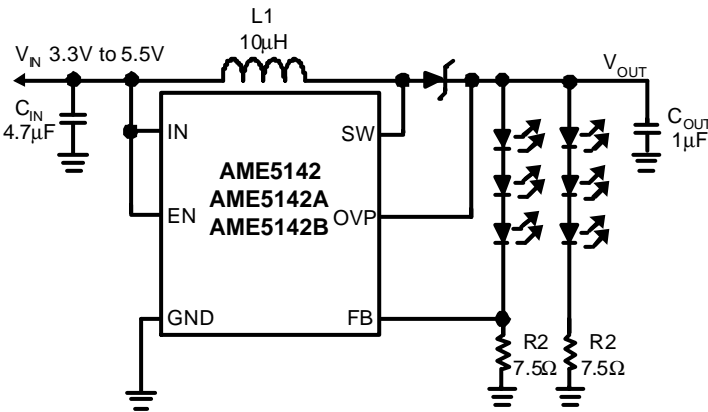
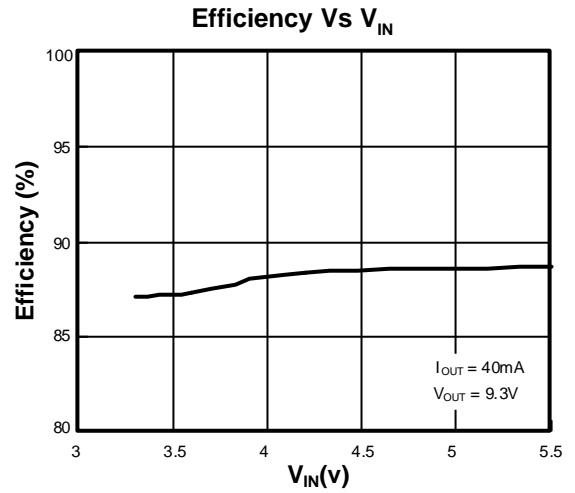
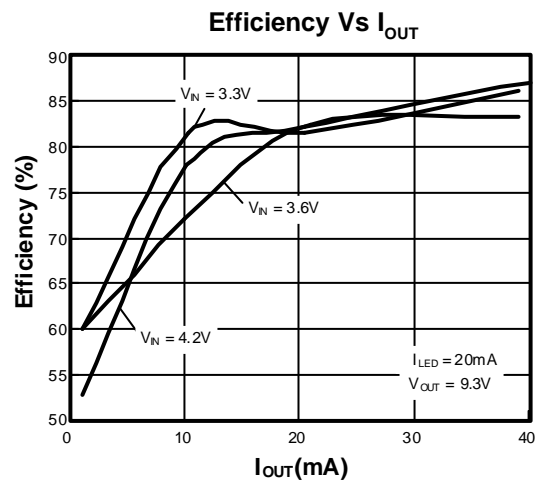

Figure 10: Circuit For Driving 2 Strings of 3 White LEDs



AME5142/5142A/5142B

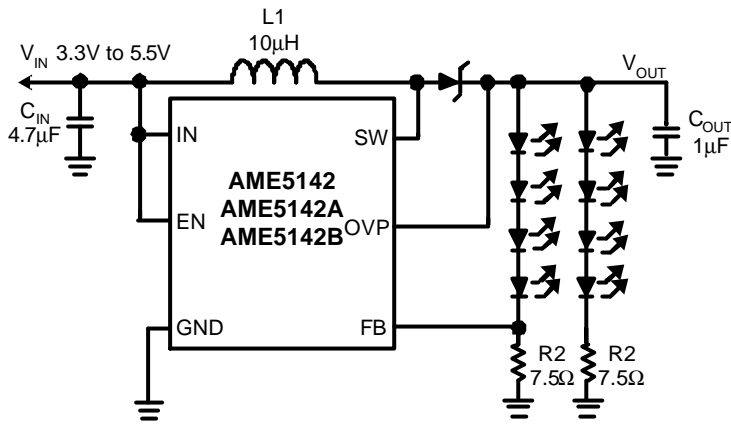

Figure 11: Circuit For Driving 2 Strings of 4 White LEDs

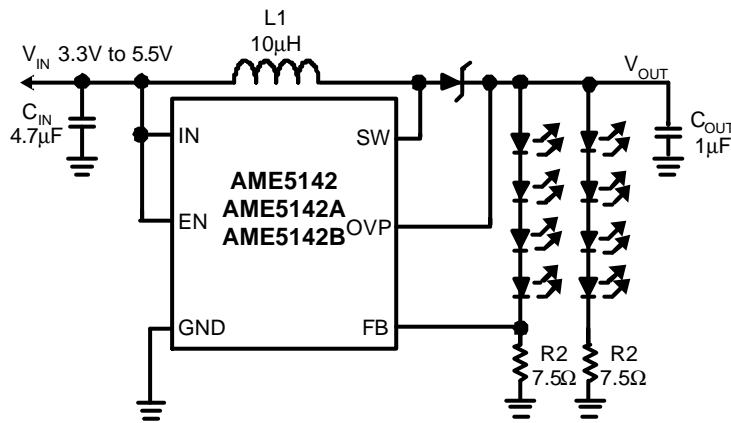
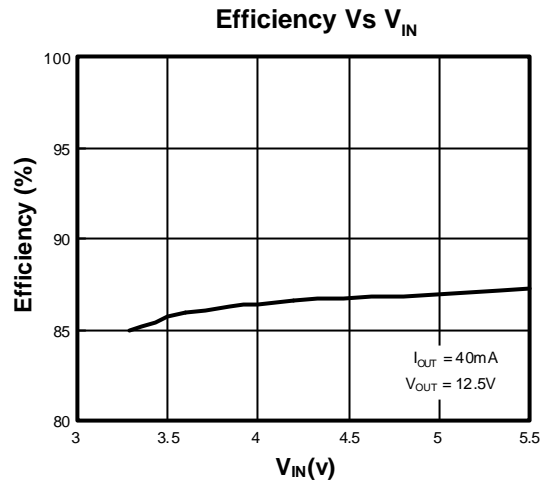

Figure 12: Circuit For Driving 2 Strings of 4 White LEDs

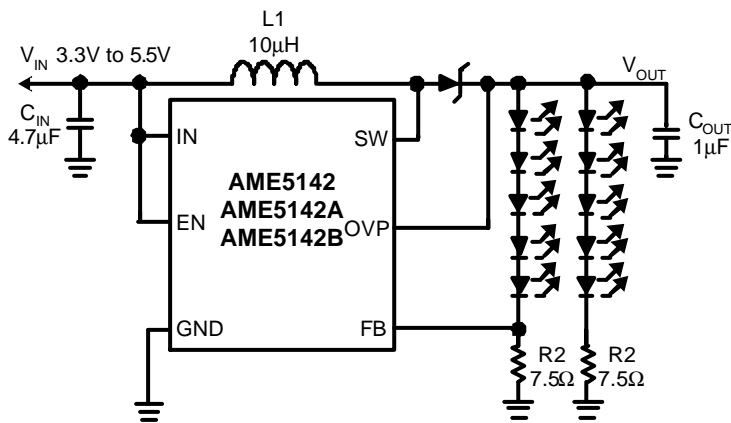
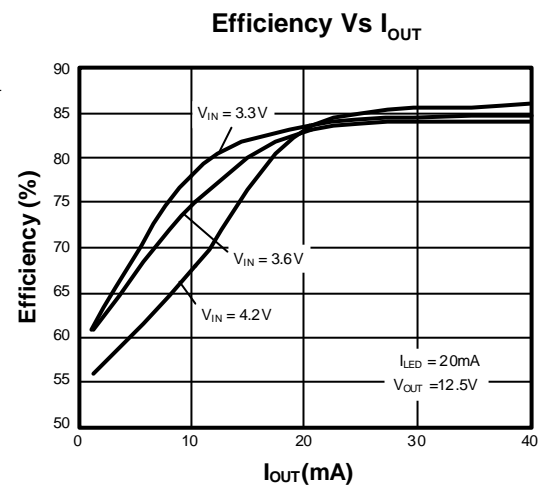
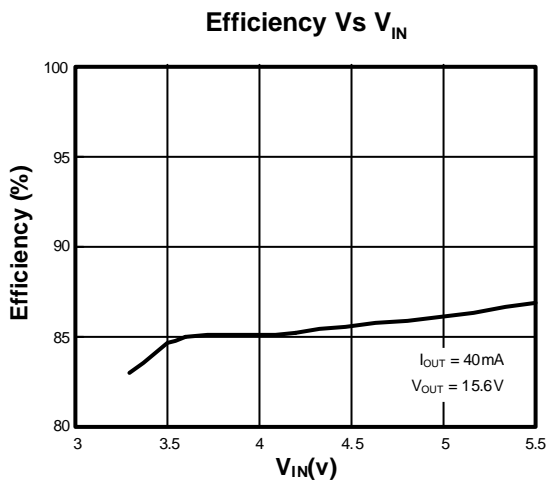

Figure 13: Circuit For Driving 2 Strings of 5 White LEDs



High Efficiency 6 White LED Driver With Open LED Protection

AME5142/5142A/5142B

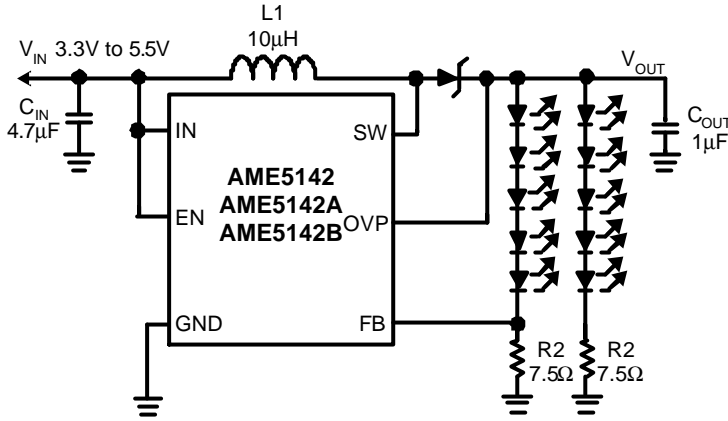

Figure 14: Circuit For Driving 2 Strings of 5 White LEDs

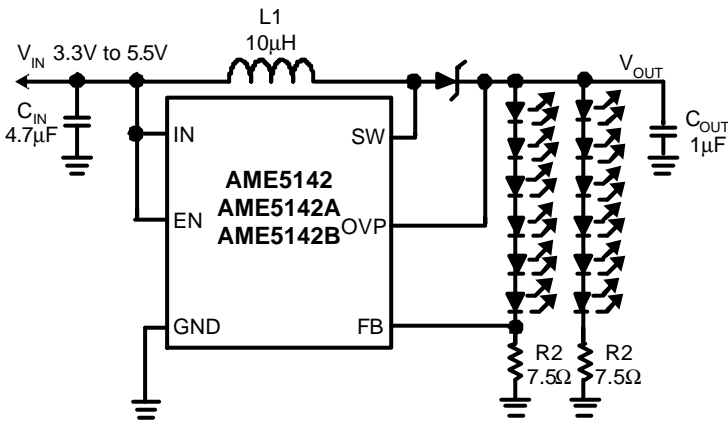
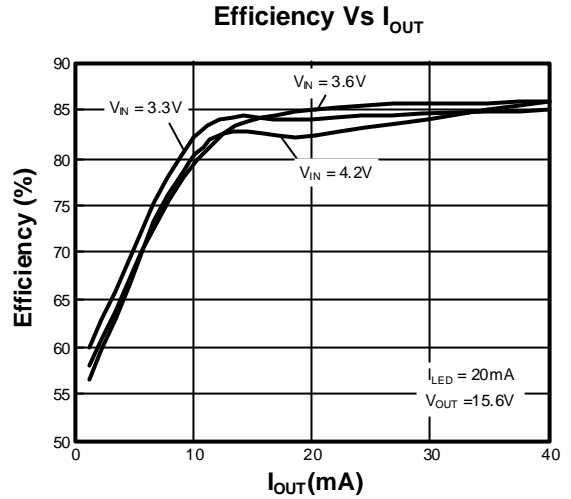

Figure 15: Circuit For Driving 2 Strings of 6 White LEDs

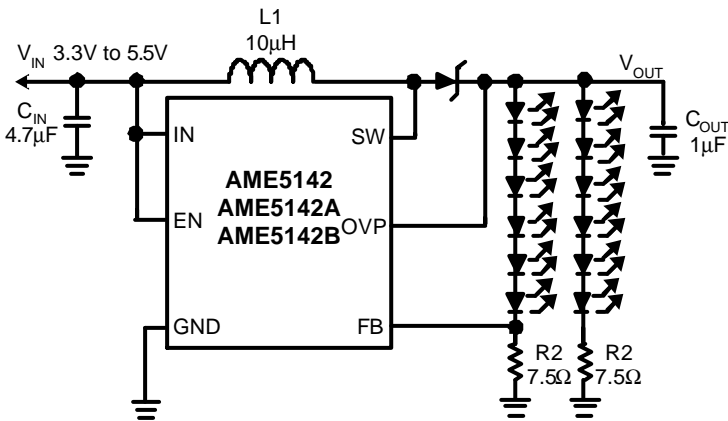
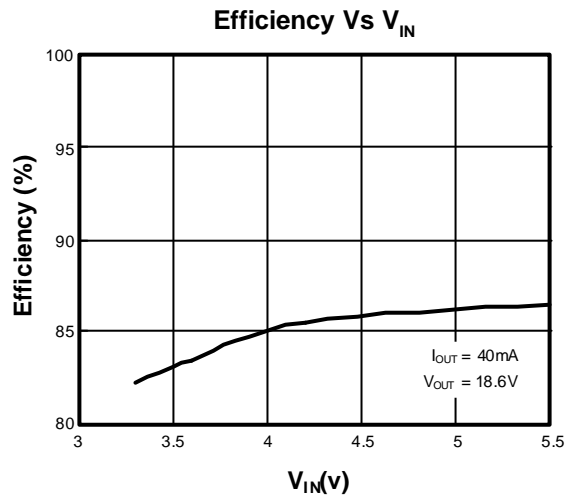
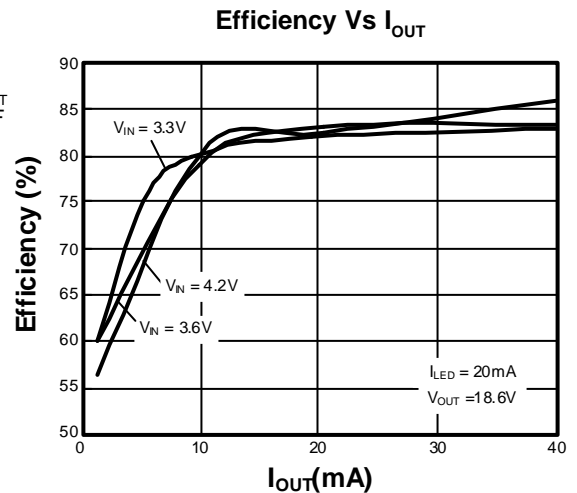
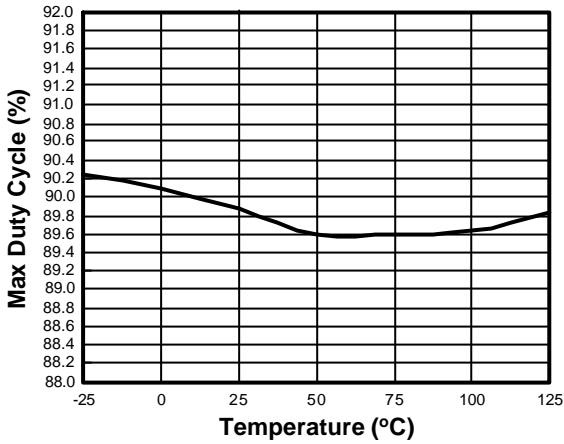
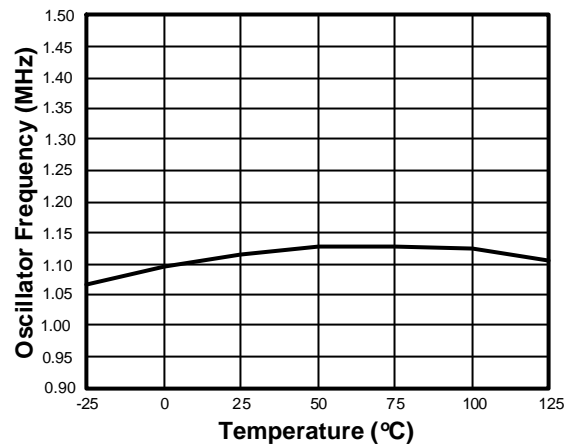
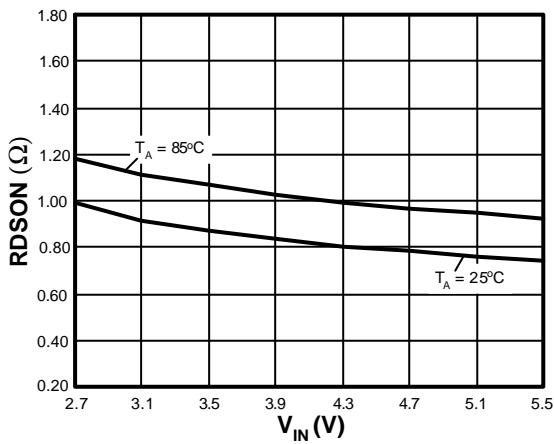
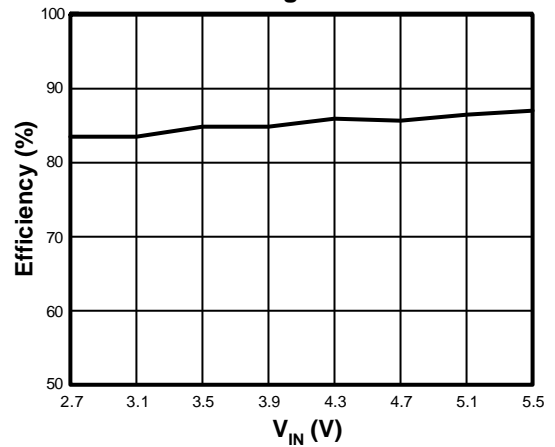
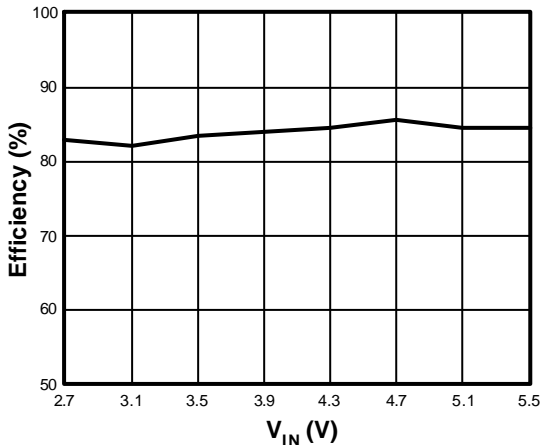
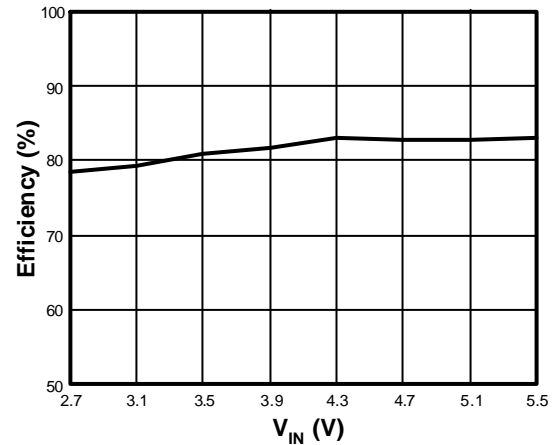

Figure 16: Circuit For Driving 2 Strings of 6 White LEDs



■ Characterization Curves
Max Duty Cycle vs. Temperature

Oscillator Frequency vs. Temperature

Switch R_{DS(on)}

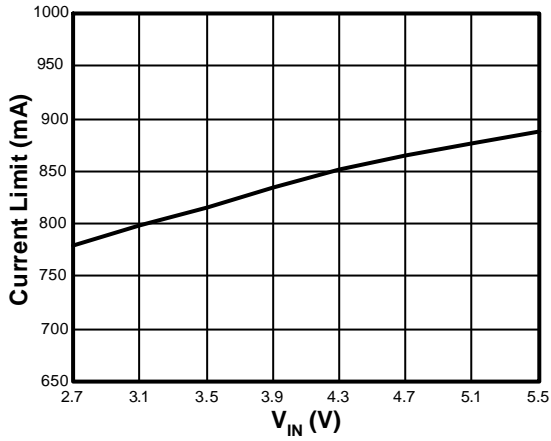
**Efficiency vs. Load Current
Dirving 3 LEDs**

**Efficiency vs. Load Current
Dirving 4 LEDs**

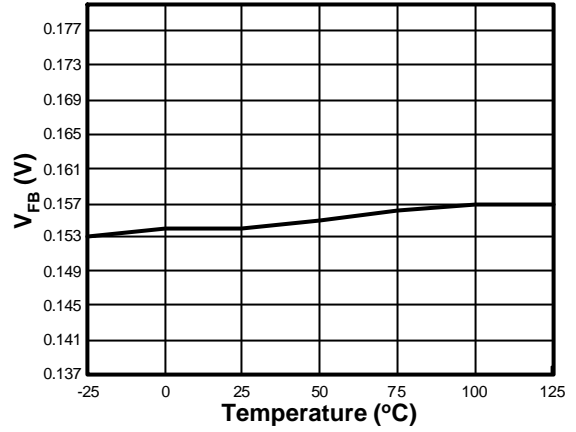
**Efficiency vs. Load Current
Dirving 6 LEDs**

AME5142/5142A/5142B

Current Limit vs. V_{IN}



V_{FB} vs. Temperature



Dimming Control for Driving 6LEDs

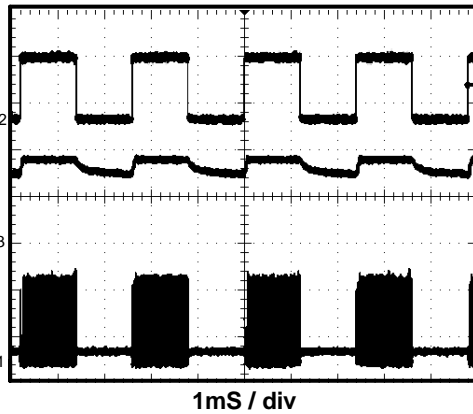

$V_{IN} = 2.7V$; 6 LEDs
 $I_{OUT} = 20mA$

- 2) EN = 1V / div, DC f = 200Hz
- 3) V_{OUT} , 10V / div, DC
- 1) V_{SW} = 10V / div, DC

Dimming Control for Driving 6LEDs

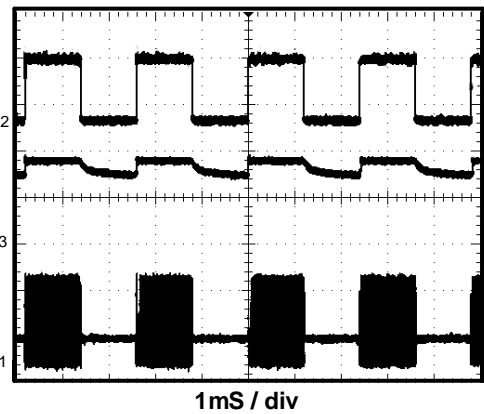

$V_{IN} = 5.5V$; 6 LEDs
 $I_{OUT} = 20mA$

- 2) EN = 1V / div, DC f = 200Hz
- 3) V_{OUT} , 10V / div, DC
- 1) V_{SW} = 10V / div, DC

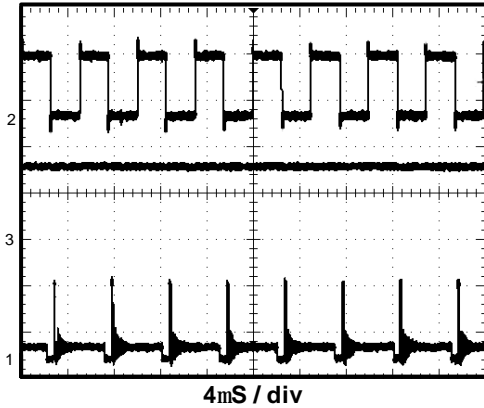
Dimming Control for Driving 6LEDs

$V_{IN} = 2.7V$; 6 LEDs
 $I_{OUT} = 20mA$

- 2) EN = 1V / div, DC f = 200KHz
- 3) V_{OUT} , 10V / div, DC
- 1) V_{SW} = 10V / div, DC

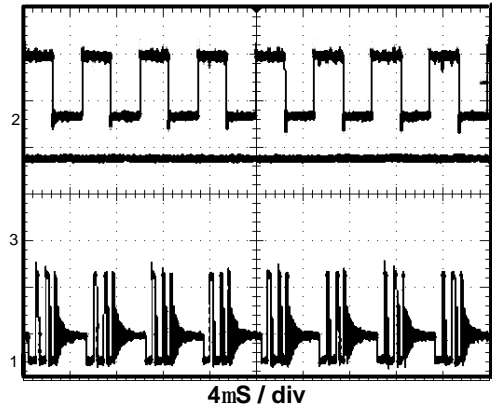
Dimming Control for Driving 6LEDs

$V_{IN} = 5.5V$; 6 LEDs
 $I_{OUT} = 20mA$

- 2) EN = 1V / div, DC f = 200KHz
- 3) V_{OUT} , 10V / div, DC
- 1) V_{SW} = 10V / div, DC

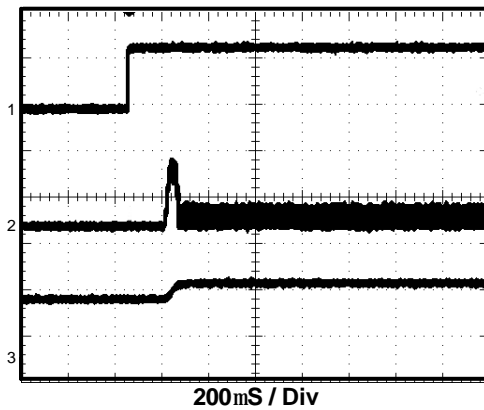
Start-Up / Shutdown

$V_{IN} = 2.7V$; 1 LEDs
 $I_{OUT} = 20mA$

- 1) EN = 2V/div, DC
- 2) Inductor Current, 100mA / div, DC
- 3) V_{OUT} , 2V / div, DC

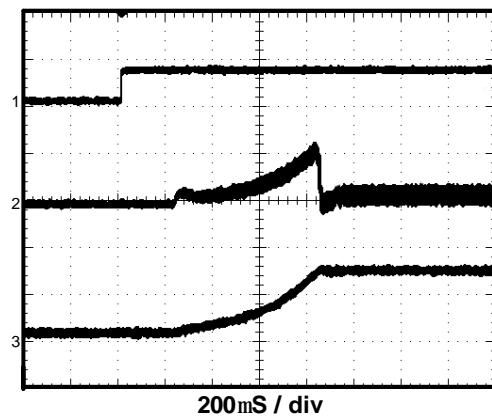
Start-Up / Shutdown

$V_{IN} = 2.7V$; 6 LEDs
 $I_{OUT} = 20mA$

- 1) EN = 2V / div, DC
- 2) Inductor Current, 500mA / div, DC
- 3) V_{OUT} , 10V / div, DC

AME5142/5142A/5142B

Start-Up / Shutdown

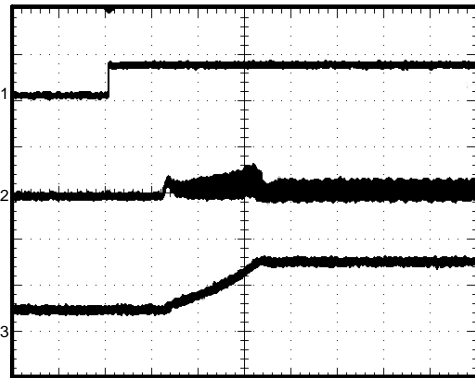

200mS / div

$V_{IN} = 5.5V$; 6 LEDs
 $I_{OUT} = 20mA$

- 1) $V_{EN} = 2V / div$, DC
- 2) Inductor Current, 500mA / div, DC
- 3) V_{OUT} , 10V / div, DC

Typical Switching Waveform

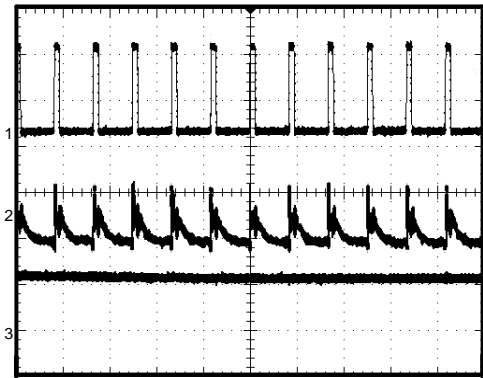

1mS / div

$V_{IN} = 2.7V$; 6 LEDs
 $I_{OUT} = 20mA$

- 1) $V_{SW} = 10V / div$, DC
 - 2) V_{OUT} , 20mV / div, AC
 - 3) Input Current, 100mA / div, DC
- Inductor = 10 μ H, $C_{OUT} = 1\mu$ F

Typical Switching Waveform

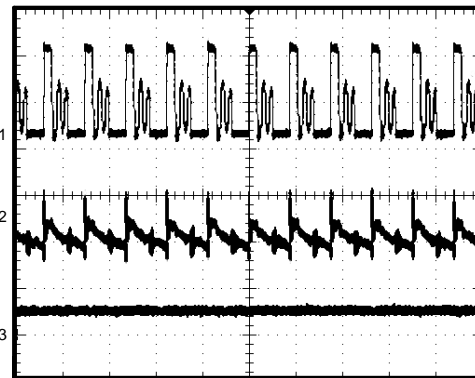

1mS / div

$V_{IN} = 5.5V$; 6 LEDs
 $I_{OUT} = 20mA$

- 1) $V_{SW} = 10V / div$, DC
 - 2) V_{OUT} , 20mV / div, AC
 - 3) Input Current, 100mA / div, DC
- Inductor = 10 μ H, $C_{OUT} = 1\mu$ F

**Start up into Openload
AME5142B**

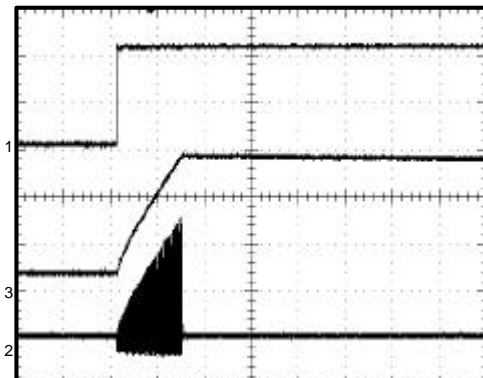

100mS / div

- 1) $V_{EN} = 2V / div$
- 2) V_{SW} , 10V / div
- 3) V_{OUT} , 10V / div

AME5142/5142A/5142B

■ Date Code Rule

Marking			Date Code		Year
A	A	A	W	W	xxx0
A	A	A	W	<u>W</u>	xxx1
A	A	A	<u>W</u>	W	xxx2
A	A	A	<u>W</u>	<u>W</u>	xxx3
A	A	<u>A</u>	W	W	xxx4
A	A	<u>A</u>	W	<u>W</u>	xxx5
A	A	<u>A</u>	<u>W</u>	W	xxx6
A	A	<u>A</u>	<u>W</u>	<u>W</u>	xxx7
A	<u>A</u>	A	W	W	xxx8
A	<u>A</u>	A	W	<u>W</u>	xxx9

■ Tape and Reel Dimension

SOT-25

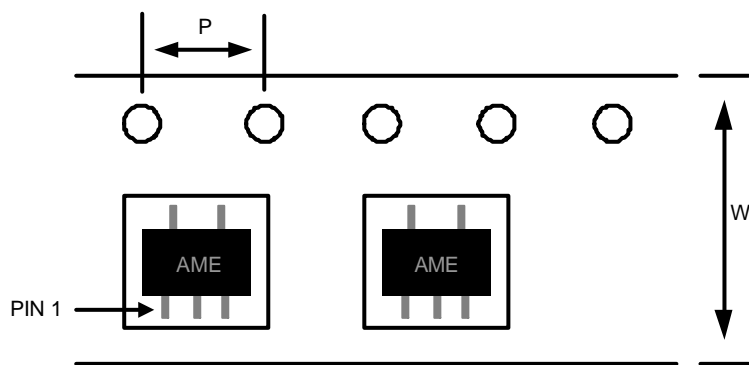

Carrier Tape, Number of Components Per Reel and Reel Size

Package	Carrier Width (W)	Pitch (P)	Part Per Full Reel	Reel Size
SOT-25	8.0±0.1 mm	4.0±0.1 mm	3000pcs	180±1 mm

AME5142/5142A/5142B

■ Tape and Reel Dimension

TSOT-25

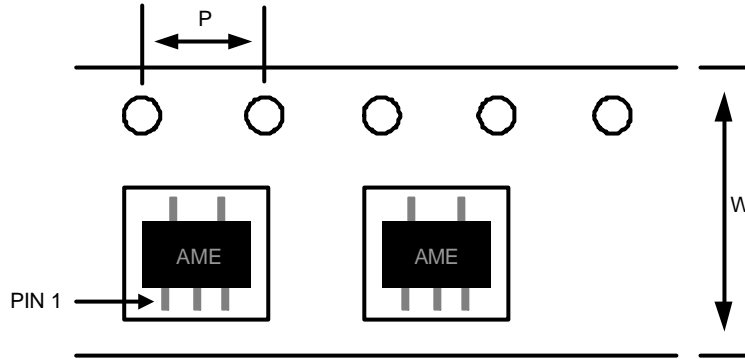

Carrier Tape, Number of Components Per Reel and Reel Size

Package	Carrier Width (W)	Pitch (P)	Part Per Full Reel	Reel Size
TSOT-25	8.0±0.1 mm	4.0±0.1 mm	3000pcs	180±1 mm

SOT-26

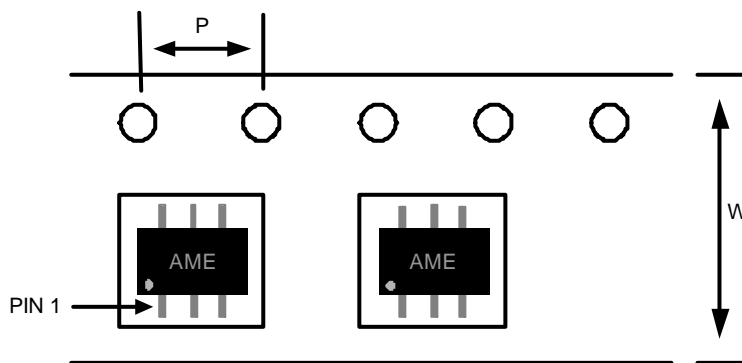

Carrier Tape, Number of Components Per Reel and Reel Size

Package	Carrier Width (W)	Pitch (P)	Part Per Full Reel	Reel Size
SOT-26	8.0±0.1 mm	4.0±0.1 mm	3000pcs	180±1 mm

■ Tape and Reel Dimension

TSOT-26

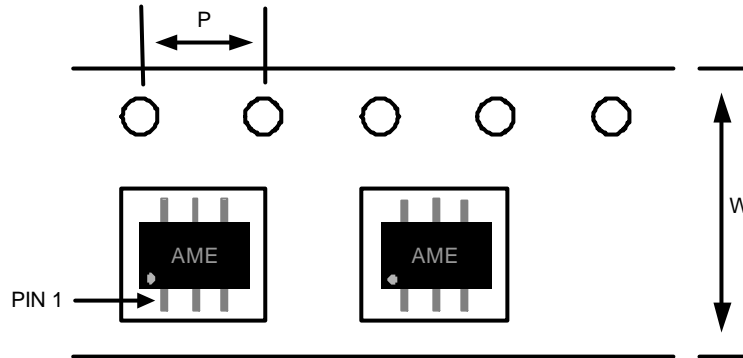

Carrier Tape, Number of Components Per Reel and Reel Size

Package	Carrier Width (W)	Pitch (P)	Part Per Full Reel	Reel Size
TSOT-26	8.0±0.1 mm	4.0±0.1 mm	3000pcs	180±1 mm

AME5142/5142A/5142B

■ Package Dimension

SOT-25

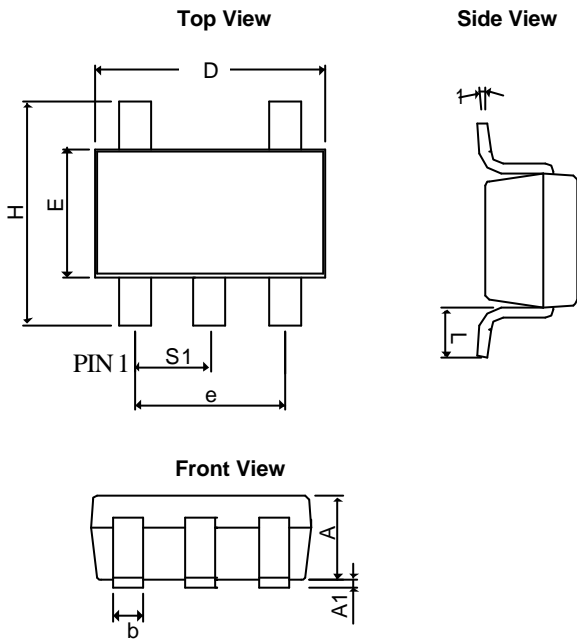

SYMBOLS	MILLIMETERS		INCHES	
	MIN	MAX	MIN	MAX
A	0.90	1.30	0.0354	0.0512
A ₁	0.00	0.15	0.0000	0.0059
b	0.30	0.55	0.0118	0.0217
D	2.70	3.10	0.1063	0.1220
E	1.40	1.80	0.0551	0.0709
e	1.90 BSC		0.07480 BSC	
H	2.60	3.00	0.10236	0.11811
L	0.37BSC		0.0146BSC	
q1	0°	10°	0°	10°
S ₁	0.95BSC		0.0374BSC	

TSOT-25

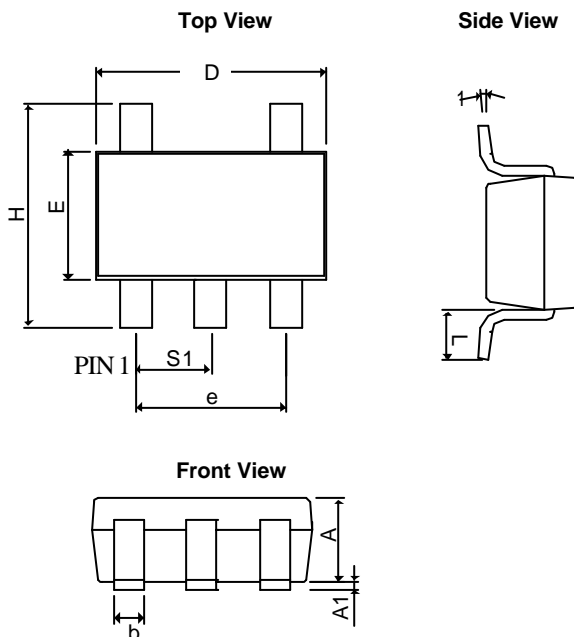

SYMBOLS	MILLIMETERS		INCHES	
	MIN	MAX	MIN	MAX
A+A ₁	0.90	1.25	0.0354	0.0492
b	0.30	0.50	0.0118	0.0197
D	2.70	3.10	0.1063	0.1220
E	1.40	1.80	0.0551	0.0709
e	1.90 BSC		0.07480 BSC	
H	2.40	3.00	0.0945	0.1181
L	0.35BSC		0.0138BSC	
q1	0°	10°	0°	10°
S ₁	0.95BSC		0.0374BSC	

AME5142/5142A/5142B

■ Package Dimension

SOT-26

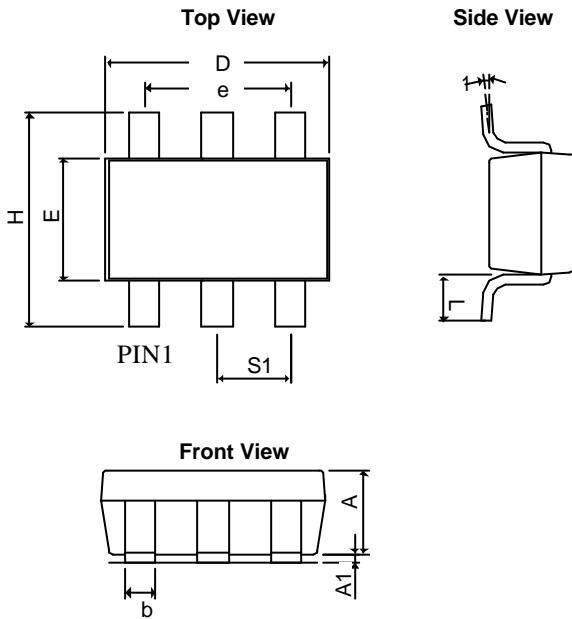

SYMBOLS	MILLIMETERS		INCHES	
	MIN	MAX	MIN	MAX
A	0.90	1.30	0.0354	0.0512
A ₁	0.00	0.15	0.0000	0.0059
b	0.30	0.55	0.0118	0.0217
D	2.70	3.10	0.1063	0.1220
E	1.40	1.80	0.0551	0.0709
e	1.90 BSC		0.07480 BSC	
H	2.60	3.00	0.10236	0.11811
L	0.37BSC		0.0146BSC	
q1	0°	10°	0°	10°
S ₁	0.95BSC		0.0374BSC	

TSOT-26

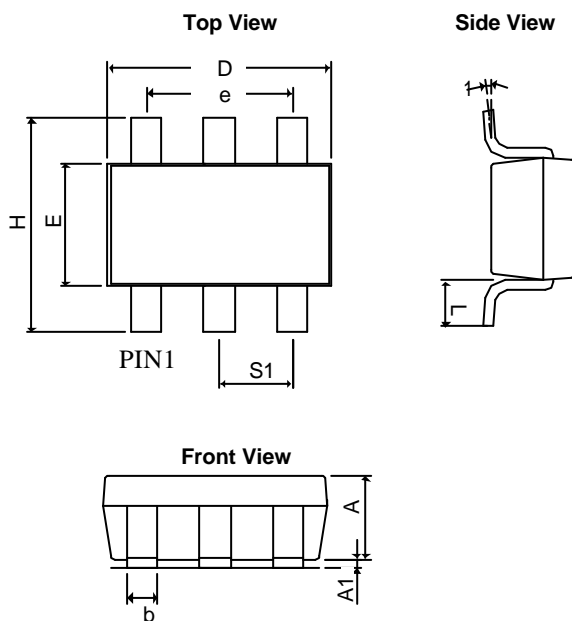

SYMBOLS	MILLIMETERS		INCHES	
	MIN	MAX	MIN	MAX
A+A ₁	0.90	1.25	0.0354	0.0492
b	0.30	0.50	0.0118	0.0197
D	2.70	3.10	0.1063	0.1220
E	1.40	1.80	0.0551	0.0709
e	1.90 BSC		0.07480 BSC	
H	2.40	3.00	0.0945	0.1181
L	0.35BSC		0.0138BSC	
q1	0°	10°	0°	10°
S ₁	0.95BSC		0.0374BSC	



www.ame.com.tw
E-Mail: sales@ame.com.tw

Life Support Policy:

These products of AME, Inc. are not authorized for use as critical components in life-support devices or systems, without the express written approval of the president of AME, Inc.

AME, Inc. reserves the right to make changes in the circuitry and specifications of its devices and advises its customers to obtain the latest version of relevant information.

© AME, Inc. , April 2009

Document: 1229-DS5142/5142A/5142B-C.02

Corporate Headquarter
AME, Inc.

2F, 302 Rui-Guang Road, Nei-Hu District

Taipei 114, Taiwan.

Tel: 886 2 2627-8687

Fax: 886 2 2659-2989