

**Umgebungslicht- und Näherungssensor mit IR Emitter**  
**Ambient Light and Proximity Sensor with Integrated IR Emitter**  
**Lead (Pb) Free Product - RoHS Compliant**

**SFH 7773**



**Preliminary datasheet**

**Wesentliche Merkmale**

- Näherungssensor- Detektionsbereich bis 150mm
  - 850nm Emitter, im Gehäuse integriert
  - Umgebungslicht-unempfindlich
- Umgebungslichtsensor
  - 0.03lx - 65000lx
  - Gute Linearität
  - Spektrale Empfindlichkeit ähnlich dem menschlichen Auge
- I<sup>2</sup>C interface
  - 100kHz / 400kHz und 3.4MHz Mode
  - verschiedene Messmoden programmierbar (Standby, Triggered, Free-running)
  - I<sup>2</sup>C-Adresse: 0111 000X
- typ 2µA Stromverbrauch im Standby Mode

**Features**

- Proximity sensor (PS)
  - Detection-range up to 150mm
  - 850nm IR emitter integrated in package
  - Insensitive to ambient light
- Ambient light sensor (ALS)
  - 0.03lx - 65000lx
  - High linearity
  - S<sub>rel</sub> well matched to the human eye
- I<sup>2</sup>C interface
  - 100kHz / 400kHz and 3.4MHz mode
  - Measurement modes programmable (Standby, Triggered, Free-running)
  - I<sup>2</sup>C slave address: 0111 000X
- Current consumption typ. 2µA in Standby mode

**Anwendungen**

- Mobiltelefone
- PDAs und Notebooks
- Kameras
- Consumer-Produkte

**Applications**

- Mobile phones
- PDAs and notebooks
- Cameras
- Consumer products

Typ Type	Bestellnummer Ordering Code
SFH 7773	Q65111A1258

## Application diagram and basic information

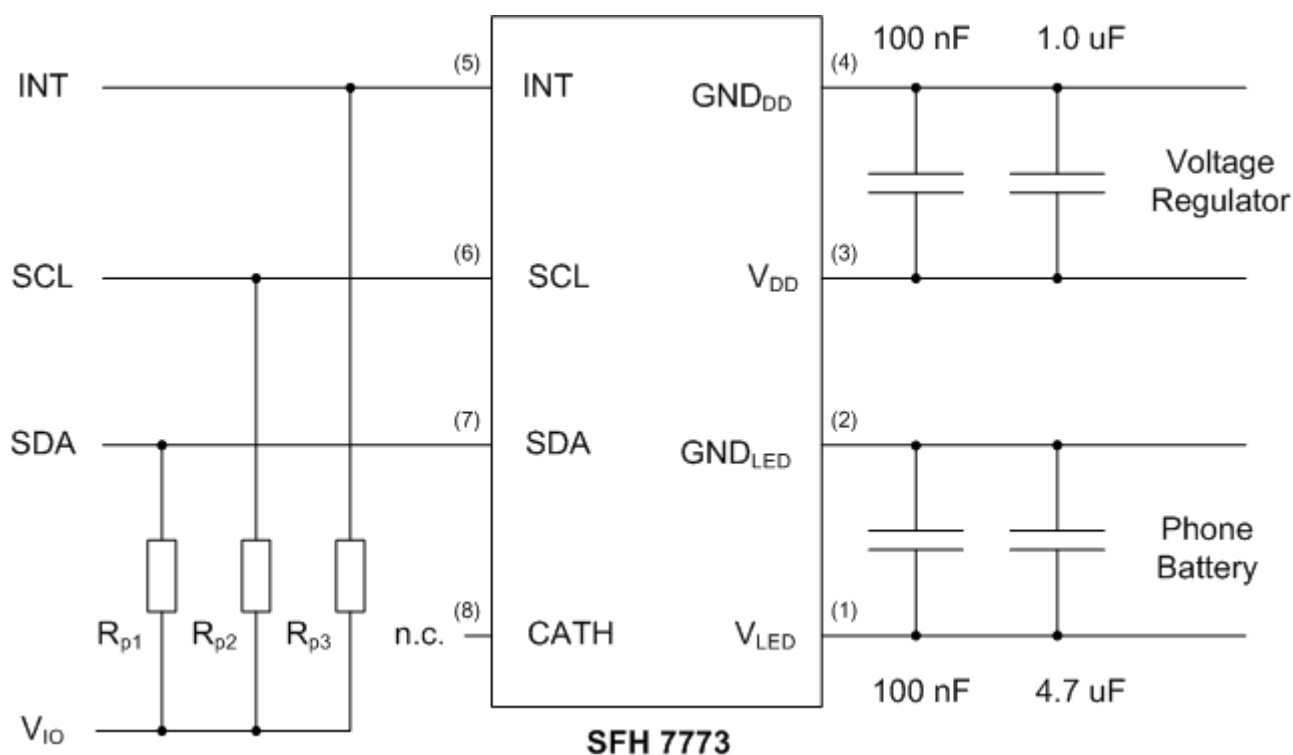

- Blocking capacitors for  $V_{DD}$  and  $V_{LED}$  are required for proper operation of the device. Based on the power supply quality the capacitor values can be reduced.
- Proposed size for the pull-up resistors is 560 Ohm.

## Short Evaluation program

Address	Command	Action
0x80	Write 03	Ambient light Sensor in FREE-RUNNING mode
0x81	Write 03	Proximity Sensor in FREE-RUNNING mode
Wait 110 ms		
0x8C	Read data	read LSByte data from ambient light measurement
0x8D	Read data	read MSByte data from ambient light measurement
0x8F	Read data	read data from proximity measurement

## I<sup>2</sup>C interface

- 1.8V I/O-logic level for SDA and SCL
- I/O-pins are open drain type and logic high level is set with external pull-up resistor
- SFH 7773 operates in slave mode with address 0x38.
- Designed for the I<sup>2</sup>C-modes: Standard (100 kb/s), Fast (400 kb/s) and High Speed (3.4 Mb/s)
- Combined format is supported (see I<sup>2</sup>C Bus specification UM10204 from NXP) for data reading
- Block READ and WRITE modes are available. In these modes several registers can be read or written during a single I<sup>2</sup>C traffic period. Registers are returned in a cyclic manner until the bus master sends the stop condition. E.g. if master uses block read and starts from register 0x8C, the slave returns the following register values: 0x8C, 0x8D, 0x8E, 0x8F, 0x90, 0x91, 0x92, 0x93, 0x94 and so on until the master sends stop condition.
- Interrupt pin (INT): open-drain output (like SDA and SCL)

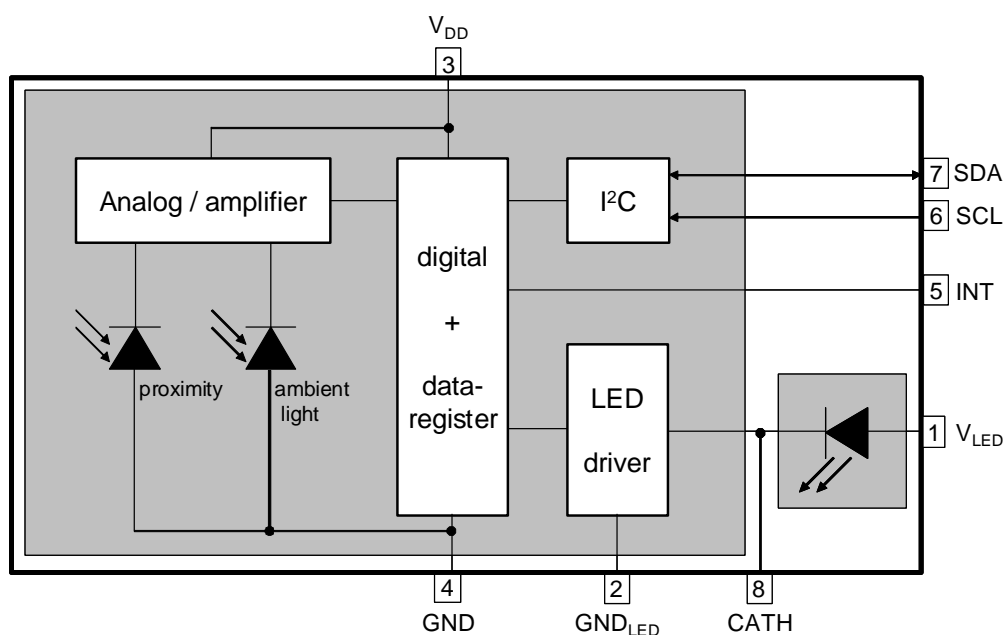

## Measurement modes

OFF	$I_{DD}$ is below $2\mu\text{A}$ and the device is inactive. Other units may use the I <sup>2</sup> C bus without any restrictions; I/O pins and INT are in Z state. There is no sink current through the LED
STAND-BY	This is the initial mode after power-up. $I_{DD}$ is below $5\mu\text{A}$ . No measurement is performed. Device can be activated by I <sup>2</sup> C bus communication. Data registers can be read and written. The data will be stored in the registers when the device goes from TRIGGERED or FREE-RUNNING to STAND-BY.
TRIGGERED	Every measurement is separately initiated by MCU. This mode can be used for ambient light sensor and proximity sensor. Measurement data are available in the registers after a defined delay time.
FREE-RUNNING	Measurements are triggered internally by SFH7773. This mode can also be used for ambient light sensor and proximity sensor. The measurement repetition rate and current through the LED is defined by MCU. Measurement results can be read from the data register, the status from the interrupt register.

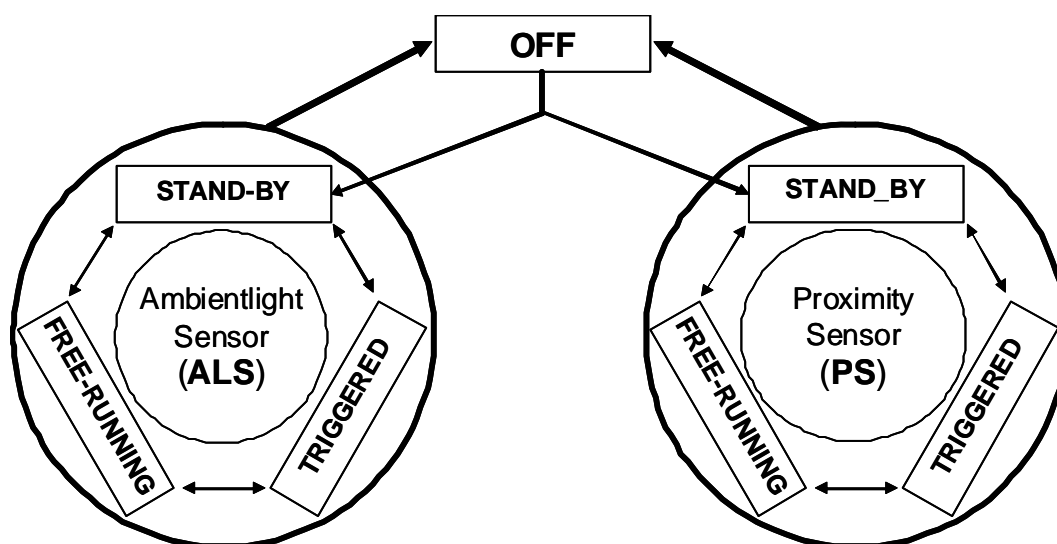

If  $V_{DD}$  exceeds the threshold-voltage, the sensor will switch from OFF mode to STAND-BY mode. As shown in the transition-diagram above it is possible to switch between all modes without any restriction. The transition time between modes ( $t_{trans}$ ) is  $< 10\text{ms}$ . The delay time between STAND-BY and start of measurement is max.  $10\text{ms}$  for the ambient light sensor.

**Maximum limits**

Parameter	Symbol	Value			Unit
		min.	typ.	max.	
Storage temperature	$T_{stg}$	- 40		+ 85	°C
Supply voltage (between $V_{DD}$ and GND)	$V_{DD}$	- 0.3		+ 4.5	V
Maximum Voltage of SDA, SCL and INT to GND	$V_{dig}$	- 0.3		+ 3.6	V
Maximum Voltage of $V_{LED}$ to GND	$V_{LED}$	- 0.3		+ 5.5	V
Maximum Voltage between GND and $GND_{LED}$	$V_{LED}$	- 0.5		+ 0.5	V
Electrostatic discharge - Human Body Model (according to JESD22-A114-E; Class2 )	$ESD$			2	kV

**Operating conditions**

Parameter	Symbol	Value			Unit
		min.	typ.	max.	
Operation temperature	$T_{op}$	- 20		85	°C
Supply Voltage	$V_{DD}$	2.3		3.1	V
Ripple on Supply Voltage ( $V_{DD}$ min and max must stay in the $V_{DD}$ range, DC ... 100MHz)	$V_{DD,rip}$			10	mV
Voltage for I/O (SDA, SCL, INT) <sup>1)</sup>	$V_{I/O}$	1.6		2.1	V
Supply Voltage LED	$V_{LED}$	2.3		4.25	V
Ripple $V_{LED}$	$V_{LED,rip}$			TBD	mV
		DC... 30kHz		TBD	mV
		30kHz ... 100MHz		TBD	mV

<sup>1)</sup> The limits for the logic levels of SCL and SDA pins are the same as in the I<sup>2</sup>C bus specification from NXP (UM10204 „I<sup>2</sup>C bus specification and user manual“, Rev. 03 - 19 June 2007). The same limits are valid for the logic levels of the interrupt pin (INT): the maximum level for logic „LOW“ level is 30% of the I/O voltage  $V_{I/O}$ , the minimum level for logic „HIGH“ level is 70% of the I/O voltage  $V_{I/O}$ .

**Characteristics** ( $T_a = 25^\circ\text{C}$ )

Parameter	Symbol	Value			Unit
		min.	typ.	max.	

**General**

Conditions for OFF mode <sup>1)</sup>	$V_{DD,off}$			1.4	V
On-time (from OFF to STAND-BY mode) <sup>1)</sup>	$t_{on}$			0.2	s
Threshold level for STAND-BY mode <sup>1)</sup>	$V_{DD,on}$	2.0			V
Transition time between modes (STAND-BY ...TRIGGERED ...FREE-RUNNING)	$t_{trans}$			10	ms
STAND-BY mode current consumption	$I_{DD,stby}$			5	$\mu\text{A}$
OFF mode current consumption	$I_{DD,off}$			2	$\mu\text{A}$
Interrupt voltage level in LOW state ( $V_{I/O}=1.8\text{V}$ )	$V_{INT,low}$			0.5	V
Interrupt voltage level in HIGH state ( $V_{I/O}=1.8\text{V}$ )	$V_{INT,high}$	1.7			V

**Proximity Sensor (PS)**

Wavelength of max. sensitivity	$\lambda_{S,max}$		850		nm
Spectral range of sensitivity (50% of $S_{max}$ )	$\lambda_{S,50\%}$		tbd		nm
LED centroid wavelength ( $I_f = 100\text{mA}$ )	$\lambda_{centroid}$		850		nm
Spectral bandwidth ( $I_f = 100\text{mA}$ )	$\Delta\lambda$		42		nm
Temperature coefficient of LED emission	TC		-0.5		%/K
Sensor signal (pseudo-logarithmic) <sup>2)</sup>			0 ... 255		count
LED current, programmable, (only when $V_{LED} - V_f \geq 0.4\text{V}$ )	$I_{LED}$	5		200	mA
Accuracy of LED current source	$\Delta I_{LED}$	-20		+20	%
Mean current consumption, FREE-RUNNING (LED „ON“, $I_f=100\text{mA}$ , $t_{rep} = 100\text{ms}$ , $V_{dd}=2.65\text{V}$ , without LED current)	$I_{act}$			300	$\mu\text{A}$
Modulation frequency of LED current	$f_{mod}$		667		kHz
Switching distance ( $I_{led}=200\text{mA}$ ; $t_{int}=750\mu\text{s}$ ; $R=90\%$ ; $A=10 \times 10\text{cm}^2$ )	$z$			5	cm
Repetition time in free-running mode programmable	$t_{rep}$		10 ... 2000		ms
Length of a single LED burst, programmable (burst length = integration time)	$t_{burst}$	100		2500	$\mu\text{s}$

---

Parameter	Symbol	Value			Unit
		min.	typ.	max.	
Update of register data after MCU request	<i>t</i>		10		ms
Insensitive to sunlight up to		50			klx

## 1) Start-up sequence

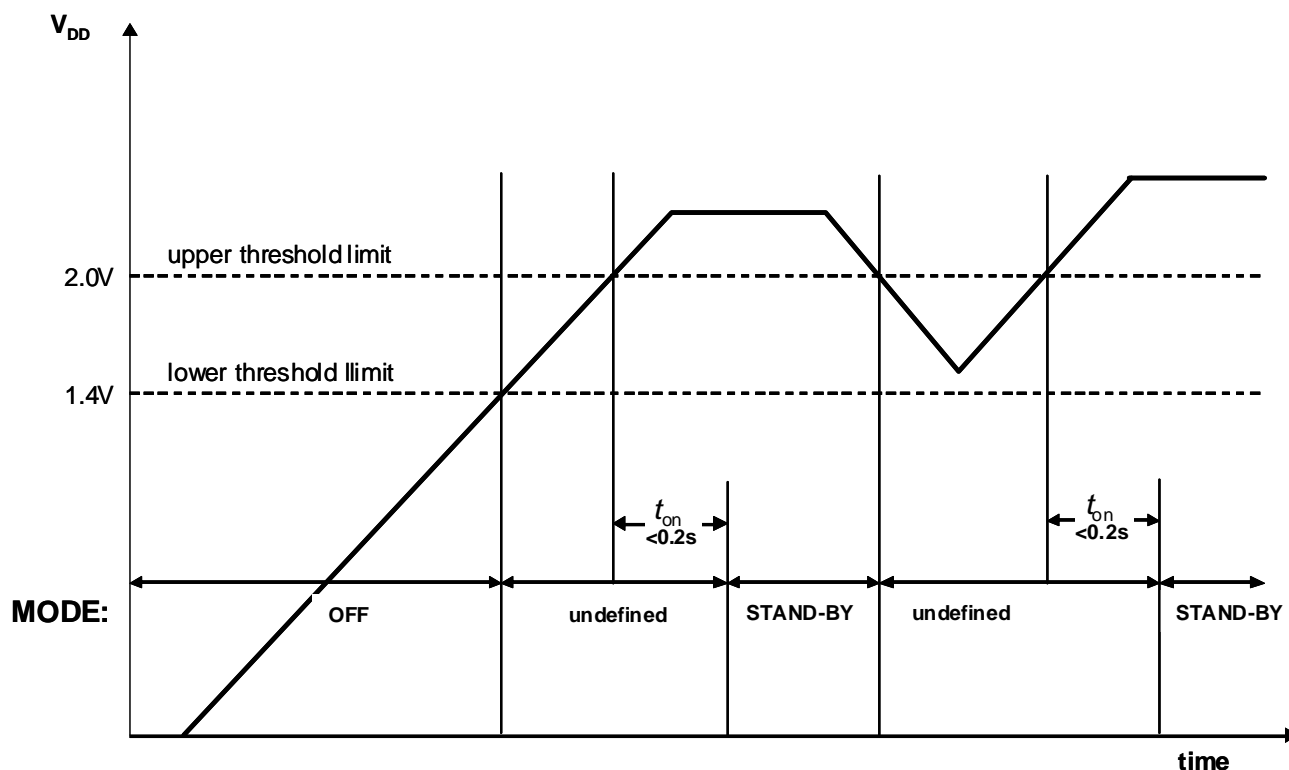

The threshold limit where the device switches from OFF to STAND-BY mode is between  $V_{DD}=1.4V$  and  $V_{DD}=2.0V$ .

Within 0.2s after exceeding the threshold voltage the device will switch from OFF to STAND-BY mode.

## 2) Output signal of the proximity sensor

The proximity sensor delivers output values in the range from 0 to 255, depending on integration time settings. Low output values correspond to low irradiance of the sensor, while high values indicate high irradiance. A threshold level for the proximity switch can be programmed via the I<sup>2</sup>C bus.



**Characteristics** ( $T_a = 25^\circ\text{C}$ )

Parameter	Symbol	Value			Unit
		min.	typ.	max.	

**Ambient Light Sensor (ALS)**

Wavelength of max. sensitivity	$\lambda$ S max		555		nm
Spectral range of sensitivity (10% of Smax)	$\lambda$ S10%	tbd		tbd	nm
Illuminance measurement range, programmable		0.03		65000	lx
Resolution of the digital output signal (0.1lx ... 6.5klx) <sup>1)</sup>	<i>Out</i>		0.1		count/lx
Deviation from linear output characteristics <sup>2)</sup> X = 10-6500lx X = 1-10lx X = 0.3-1lx	$f_{lin}$		$\pm 5$ $\pm 10$ $\pm 30$		%
Temperature coefficient for $E_v$ measurement 0°C ... 50°C -15°C ... 70°C	$T_{cEv}$	- 0.20 - 0.25		+ 0.20 + 0.25	%/K %/K
Update of register data after MCU request <sup>1)</sup>	<i>t</i>		100	120	ms
Measurement repetition time in FREE-RUNNING mode, programmable	$t_{rep}$		100 ... 2000		ms
integration time, programmable <sup>1)</sup>	$t_{int}$	10		1000	ms
Mean current consumption, $t_{rep} = 500\text{ms}$ ; $t_{int} = 10\text{ms}$ ; $V_{dd} = 2.65\text{V}$ ; $E_v = 1000\text{lx}$	$I_{act}$			200	$\mu\text{A}$
Current consumption in STAND-BY mode	$I_{stby}$		2	5	$\mu\text{A}$
Error by Flicker noise (caused by bulbs or fluorescent lamps) (f = 50 or 60Hz, 100% modulation)		-5		+5	%

<sup>1)</sup> The absolute resolution range of the ALS depends on the integration time. This can be set in register 0x26. Default value is 100ms resulting in a resolution range of 0.3 lx ... 6500 lx. To access register 0x26, register 0x20 must first be set to 0x01. After changing the integration time it is recommended to set register 0x20 back to 0x00.

2) The deviation of the linear output characteristic is referenced to 1000lx and follows the formula:

$$f_{\text{lin}} = \left( \frac{Y_X}{Y_{1000\text{lx}}} \times \frac{1000\text{lx}}{X} - 1 \right) \times 100\%$$

X: sensor illumination level in lux

$Y_X$ : sensor output / measurement value at illumination level X

$Y_{1000\text{lx}}$ : sensor output / measurement value at illumination level 1000lx

**Note:** Some of the following registers are marked as unused. They can still be accessed by block write and read procedures.

### Integration Time access register

Note: After setting bit '0' there must be stop condition to confirm writing.

R/W-Register 0x20								
Bit	7	6	5	4	3	2	1	0
	not used							
default	0	0	0	0	0	0	0	0 not accessible
								0 not accessible
								1 accessible

### Ambient light sensor Integration Time

Note: Register 0x26 is only accessible if access-bit '0' of register 0x20 is set to '1'. Integration time can then be changed. It is recommended to set access-bit '0' of the Integration Time Access register afterwards back to '0'. When reading or writing in block-read/-write mode, it is recommended to start at register 0x26 and stop at register 0x27, as there are other registers accessible which are not intended for user access. Afterwards set the access bit of register 0x20 back to 0.

Note that the absolute ambient light sensor range depends on the integration time. I.e. default setting range is 0.3 lx to 6.5 klx with resolution of 0.1 lx per count, whereas 10 ms results in a range of 3 lx to 65 klx with 1 lx resolution per count.

R/W-Register 0x26									
Bit	7	6	5	4	3	2	1	0	
	not used					ALS integration time			
default	0000000					000	100 ms		
						000	100 ms		
						001	200 ms		
						010	500 ms		
						011	1000 ms		
						100	10 ms		
						101	20 ms		
						110	50 ms		
						111	50 ms		

### Proximity sensor Integration Time

Note: Register 0x27 is only accessible if access-bit '0' of register 0x20 is set to '1'. Integration time can then be changed. It is recommended to set access-bit '0' of the Integration Time Access register afterwards back to '0'. When reading or writing in block-read/-write mode, it is recommended to start at register 0x26 and stop at register 0x27, as there are other registers accessible which are not intended for user access. Afterwards set the access bit of register 0x20 back to 0.

Note that the PS Integration Time sets the absolute PS signal count. I.e. an integration time of 1000 us delivers a signal count which is around 50 counts higher compared to an integration time of 100 us. A factor of 10 in signal level (resp. integration time) corresponds to around an increase of 50 counts (pseudo-logarithmic relationship).

R/W-Register 0x27								
Bit	7	6	5	4	3	2	1	0
	not used				PS integration time			
default	0000000				010	300 us		
					000	100 us		
					001	200 us		
					010	300 us		
					011	500 us		
					100	750 us		
					101	1000 us		
					110	1500 us		
					111	2500 us		

## Software reset and control of ambient light sensor

R/W-Register 0x80								
Bit	7	6	5	4	3	2	1	0
	not used				complete SW reset		mode of ambient light sensor	
default	00000				0		00 STAND-BY	
					1 SW reset		00 STAND-BY	
							01 STAND-BY	
							10 TRIGGERED (by MCU)	
							11 FREE-RUNNING (internally triggered)	

SW reset (Bit 3 „H“) sets all registers to default (same as POWER UP). The bit is set back to „L“ by SFH7773 automatically.

## Control of proximity sensor

R/W-Register 0x81								
Bit	7	6	5	4	3	2	1	0
	not used				mode of Proximity Sensor			
default	XXXXXX				00 STAND-BY			
					00 STAND-BY			
					01 STAND-BY			
					10 TRIGGERED by MCU			
					11 FREE-RUNNING (internally triggered)			

## Emitter current setting

R/W-Register 0x82								
Bit	7	6	5	4	3	2	1	0
	activation of LEDs		not used			setting LED pulse current		
default	00		011			011 50 mA		
	00 LED active		XXX			000 5 mA		
						001 10 mA		
						010 20 mA		
						011 50 mA		
						100 100 mA		
						101 150 mA		
						110 200 mA		

## Register is not used, but might be read during block read mode

R/W-Register 0x83								
Bit	7	6	5	4	3	2	1	0
	Not used					Not used		
default	00000					011		

## MCU-triggered measurement (for ambient light sensor and proximity sensor)

R/W-Register 0x84									
Bit	7	6	5	4	3	2	1		0
	not used						trigger ambient light		trigger proximity
default	XXXXXX						1		1

If „1“ is set a new measurement will start after I<sup>2</sup>C stop command from MCU. As soon as the measurement is finished the corresponding bit of the register will be set to „0“ automatically by the SFH7773

## Proximity measurement: time interval settings (repetition time) for FREE-RUNNING mode

R/W-Register 0x85								
Bit	7	6	5	4	3	2	1	0
	not used				time-interval			
default	XXXX				0101	100 ms		
					0000	10 ms		
					0001	20 ms		
					0010	30 ms		
					0011	50 ms		
					0100	70 ms		
					0101	100 ms		
					0110	200 ms		
					0111	500 ms		
					1000	1000 ms		
					1001	2000 ms		

**Ambient light measurement: time interval settings (repetition time) for FREE-RUNNING mode**

R/W-Register 0x86								
Bit	7	6	5	4	3	2	1	0
	not used					time-interval		
default	XXXXX					010	500 ms	
						000	100 ms	
						001	200 ms	
						010	500 ms	
						011	1000 ms	
						100	2000 ms	

**Part number and revision Identification**

R-Register 0x8A								
Bit	7	6	5	4	3	2	1	0
	Part number ID				Revision ID			
	1001				0111			

**Manufacturer Identification**

R-Register 0x8B								
Bit	7	6	5	4	3	2	1	0
	Manufacturer Identification							
	0000				0011			



**Ambient light measurement data (0x8C: LSB , 0x8D: MSB )**

R-Register 0x8C								
Bit	7	6	5	4	3	2	1	0
	LSB data							
default	00000000							

R-Register 0x8D								
Bit	7	6	5	4	3	2	1	0
	MSB data							
default	00000000							

The result of the ambient light sensor is a 16bit word with MSB and LSB and is stored in two registers.. The binary data can be converted directly to decimal „lx“ values (max. 65535lx)

**Status of measurement data for ambient light sensor (ALS) and proximity sensor (PS)**

R-Register 0x8E								
Bit	7	6	5	4	3	2	1	0
	ALS threshold	ALS data	Not used				PS LED threshold	PS LED data
default	00		0000				00	

When the measurement is available in the register the corresponding statusbit (bit 6 for ambient-light; bit 0 for proximity) in register 0x8E is set to „1“; when the measurement has been read by the MCU the statusbit is automatically set back to „0“.

Bit 7 is set „1“ when the measured ALS value is outside the threshold level settings (register 0x96... 0x99). Bit 1 is set when the measured PS value is above the threshold level (register 0x93).

The status of register 0x8E will always be updated when a new measurement is available.

**Proximity measurement data (8bit, logarithmic scale)**

R-Register 0x8F								
Bit	7	6	5	4	3	2	1	0
	data							
default	00000000							

Register is not used, but might be read during block read mode

R-Register 0x90								
Bit	7	6	5	4	3	2	1	0
	Not used							
default	00000000							

Register is not used, but might be read during block read mode

R-Register 0x91								
Bit	7	6	5	4	3	2	1	0
	Not used							
default	00000000							

Interrupt register / INT output.

R/W-Register 0x92								
Bit	7	6	5	4	3	2	1	0
	not used	Interrupt trigger source		not used	Output mode		Output polarity	Interrupt mode (triggered by..)
R/W	not used	R only		not used	R/W		R/W	R/W
default	X	00		X	1		0	00
		00 ALS			0 latched		0 active L	00 Z state
		01 PS			1 not latched		1 active H	01 only PS
								10 only ALS
								11 PS and ALS

In Bit6/5 the source which triggers the interrupt is noted. Data from Status Register (0x8E) are used. In latched mode (set by bit3) this remains unchanged until the Interrupt register has been read by the MCU, afterwards it is set to 0 automatically. In unlatched mode it is updated after every measurement.

The Output polarity (pin 5 of the SFH7773) can be changed by bit 2.

Interrupt can be triggered by the ambient light sensor and / or by the proximity sensor; this can be set in the Interrupt mode (bit 1/bit 0); when bit 1 and bit 0 is set to 0 the INT Output is in the Z state (high impedance).

## Threshold level for Proximity Sensor

RW-Register 0x93								
Bit	7	6	5	4	3	2	1	0
	data							
default	11111111							

## Register is not used, but might be read during block read mode

RW-Register 0x94								
Bit	7	6	5	4	3	2	1	0
	Not used							
default	11111111							

## Register is not used, but might be read during block read mode

RW-Register 0x95								
Bit	7	6	5	4	3	2	1	0
	Not used							
default	11111111							

## Upper threshold level for ambient light Sensor (LSB)

RW-Register 0x96								
Bit	7	6	5	4	3	2	1	0
	LSB data (upper threshold)							
default	11111111							

## Upper threshold level for ambient light Sensor (MSB)

RW-Register 0x97								
Bit	7	6	5	4	3	2	1	0
	MSB data (upper threshold)							
default	11111111							

## Lower threshold level for ambient light Sensor (LSB)

RW-Register 0x98								
Bit	7	6	5	4	3	2	1	0
	LSB data (lower threshold)							
default	00000000							

## Lower threshold level for ambient light Sensor (MSB)

RW-Register 0x99								
Bit	7	6	5	4	3	2	1	0
	MSB data (lower threshold)							
default	00000000							

## Package Outlines

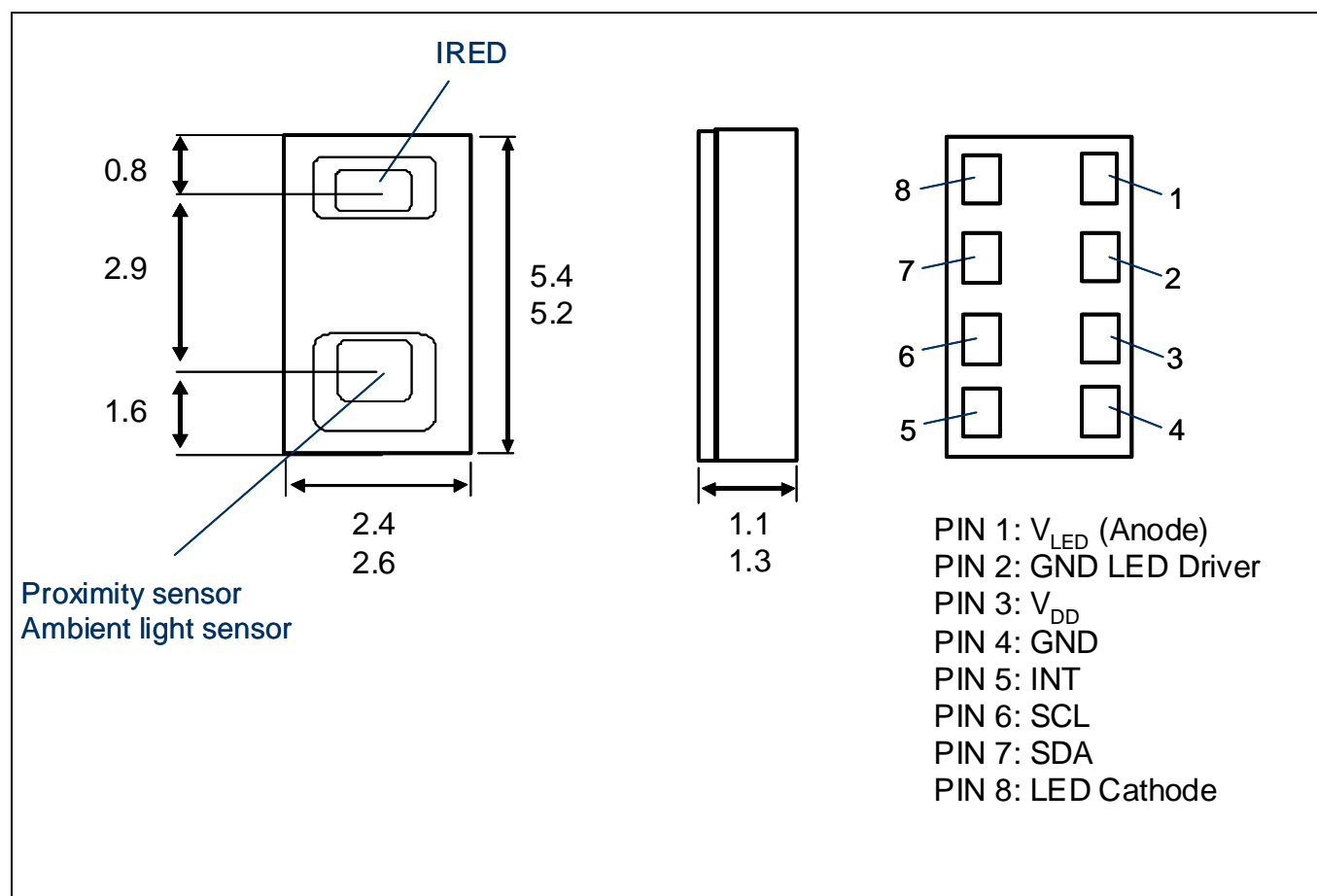

Dimensions in mm

Tolerance of package dimensions is +/- 0.1mm if not stated otherwise.

## Recommended solderpad design

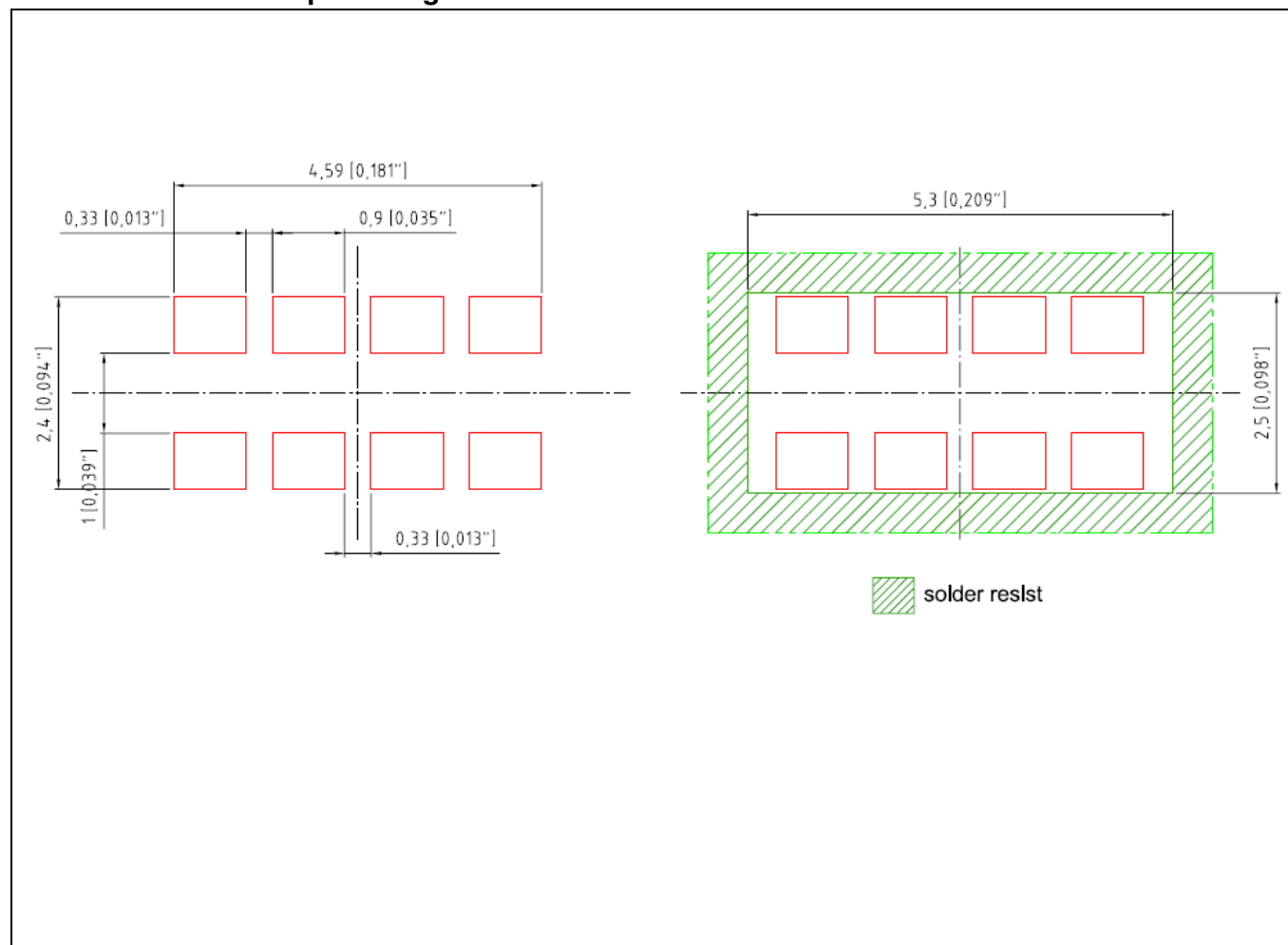

Dimensions in mm [inch]

**Soldering Conditions****Reflow Soldering Profile for lead free soldering**

Preconditioning acc. to JEDEC Level 3

(acc. to J-STD-020-D.01)

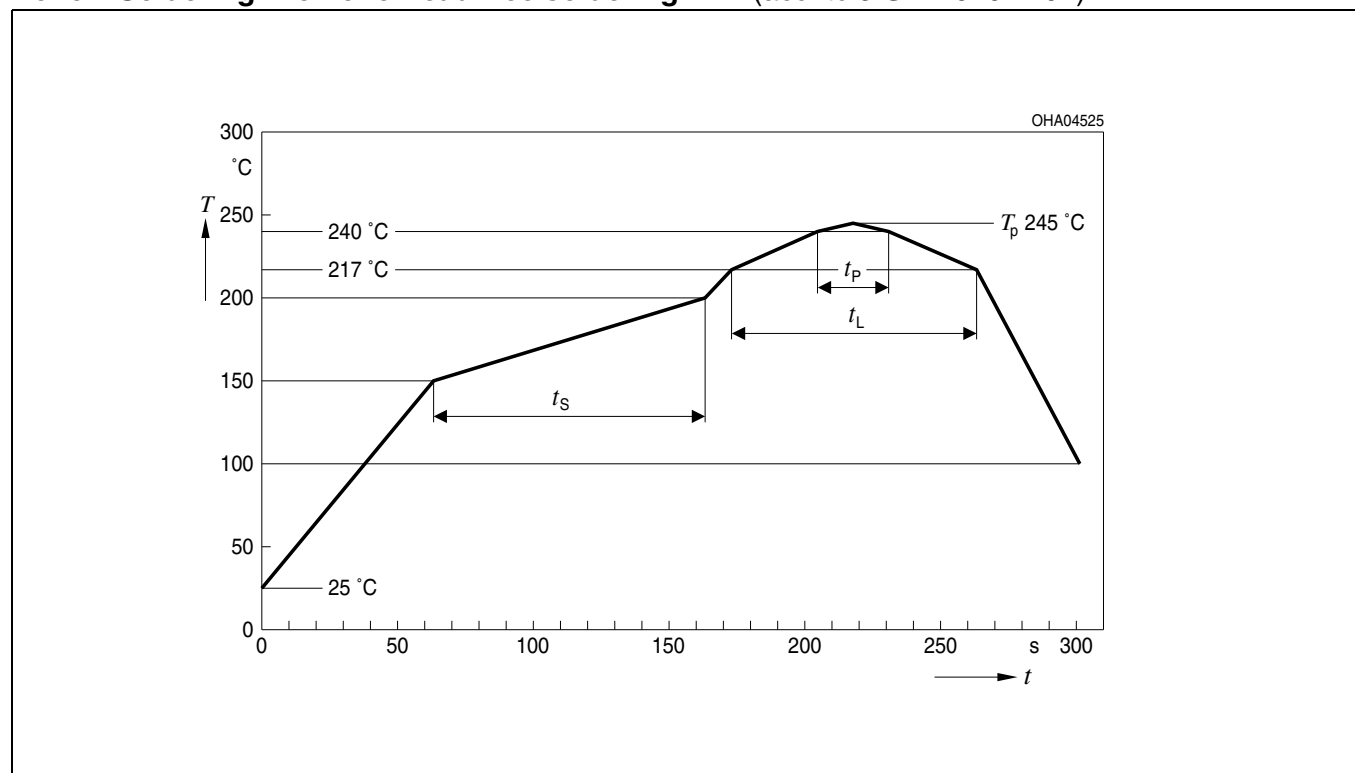
**Cleaning / Washing**

In general, OSRAM Opto Semiconductors does not recommend a wet cleaning process for components like the **OSTAR SMT, OSTAR Compactand SFH777x 3in1** as the package is not hermetically sealed. Due to the open design, all kind of cleaning liquids can infiltrate the package and cause a degradation or a complete failure of the **LED / ASIC**. It is also recommended to prevent penetration of organic substances from the environment which could interact with the hot surfaces of the operating chips. Ultrasonic cleaning is generally not recommended for all types of LEDs (see also the application note "Cleaning of LEDs"). As is standard for the electronic industry, OSRAM Opto Semiconductors recommends using low-residue or no-clean solder paste, so that PCB cleaning after soldering is no longer required. In any case, all materials and methods should be tested beforehand in order to determine whether the component will be damaged in the process.

Pb-Free (SnAgCu) Assembly		
Profile Feature	Recommendation	Max. Ratings
Ramp-up Rate to Preheat*) 25°C to 150°C	2°C / sec	3°C / sec
Time $t_s$ from $T_{Smin}$ to $T_{Smax}$ (150°C to 200°C)	100s	min. 60sec max. 120sec
Ramp-up Rate to Peak*) $T_{Smax}$ to $T_P$	2°C / sec	3°C / sec
Liquidus Temperture $T_L$	217°C	
Time $t_L$ above $T_L$	80sec	max. 100sec
Peak Temperature $T_P$	245°C	max. 260°C
Time $t_p$ within 5°C of the specified peak temperature $T_P$ - 5K	20sec	min. 10sec max. 30sec
Ramp-down Rate* $T_P$ to 100°C	3°C / sec	6°C / sec maximum
Time 25°C to Peak temperature		max. 8 min.

All temperatures refer to the center of the package, measured on the top of the component

\* slope calculation  $\Delta T/\Delta t$ :  $\Delta t$  max. 5 sec; fulfillment for the whole T-range

**Published by**  
**OSRAM Opto Semiconductors GmbH**

Leibnizstr. 4, D-93055 Regensburg

[www.osram-os.com](http://www.osram-os.com)

© All Rights Reserved.

The information describes the type of component and shall not be considered as assured characteristics. Due to the special conditions of the manufacturing processes of Sensor, the typical data or calculated correlations of technical parameters can only reflect statistical figures. These do not necessarily correspond to the actual parameters of each single product, which could differ from the typical data and calculated correlations or the typical characteristic line. If requested, e.g. because of technical improvements, these typ. data will be changed without any further notice.

Terms of delivery and rights to change design reserved. Due to technical requirements components may contain dangerous substances. For information on the types in question please contact our Sales Organization.

**Packing**

Please use the recycling operators known to you. We can also help you – get in touch with your nearest sales office. By agreement we will take packing material back, if it is sorted. You must bear the costs of transport. For packing material that is returned to us unsorted or which we are not obliged to accept, we shall have to invoice you for any costs incurred.

**Components used in life-support devices or systems must be expressly authorized for such purpose!** Critical components <sup>1</sup>, may only be used in life-support devices or systems <sup>2</sup> with the express written approval of OSRAM OS.

<sup>1</sup> A critical component is a component used in a life-support device or system whose failure can reasonably be expected to cause the failure of that life-support device or system, or to affect its safety or effectiveness of that device or system.

<sup>2</sup> Life support devices or systems are intended (a) to be implanted in the human body, or (b) to support and/or maintain and sustain human life. If they fail, it is reasonable to assume that the health of the user may be endangered.