

Stellaris® Robotic Evaluation Board

User's Manual



Copyright

Copyright © 2010 Texas Instruments, Inc. All rights reserved. Stellaris and StellarisWare are registered trademarks of Texas Instruments. ARM and Thumb are registered trademarks, and Cortex is a trademark of ARM Limited. Other names and brands may be claimed as the property of others.

Texas Instruments
108 Wild Basin, Suite 350
Austin, TX 78746
<http://www.ti.com/stellaris>



Table of Contents

Chapter 1: Board Overview	9
Features.....	9
Block Diagram	10
Specifications.....	12
Chapter 2: Hardware Description	13
LM3S9B92 Microcontroller	13
Clocking	13
Reset.....	13
Power Supplies	13
Organic LED Display.....	14
microSD CARD	14
Audio.....	14
Ethernet	14
USB.....	15
Robotic Features.....	15
Expansion	15
Debugging.....	15
Appendix A: Schematics	17
Appendix B: Component Locations	23
Appendix C: Bill of Materials (BOM)	25
Appendix D: References	29

List of Figures

Figure 1-1. Stellaris® EVALBOT Robot.....	9
Figure 1-2. EVALBOT Block Diagram	11
Figure B-1. EVALBOT Component Locations.....	23

List of Tables

Table 1-1. EVALBOT Specifications.....	12
Table 2-1. EVALBOT Power Supplies.....	14
Table 2-2. Connector Part Numbers.....	15
Table C-1. EVALBOT Bill of Materials (BOM).....	25

Board Overview

The Stellaris® Robotic Evaluation Board (EVALBOT) is a robotic evaluation platform for the Stellaris LM3S9B92 microcontroller. The board also uses a range of Texas Instruments analog components for motor drive, power supply, and communications functions. The EVALBOT's electronics arrive ready-to-run. The board's robotics capabilities require less than 30 minutes of mechanical assembly. Figure 1-1 shows a photo of the EVALBOT.

Figure 1-1. Stellaris® EVALBOT Robot

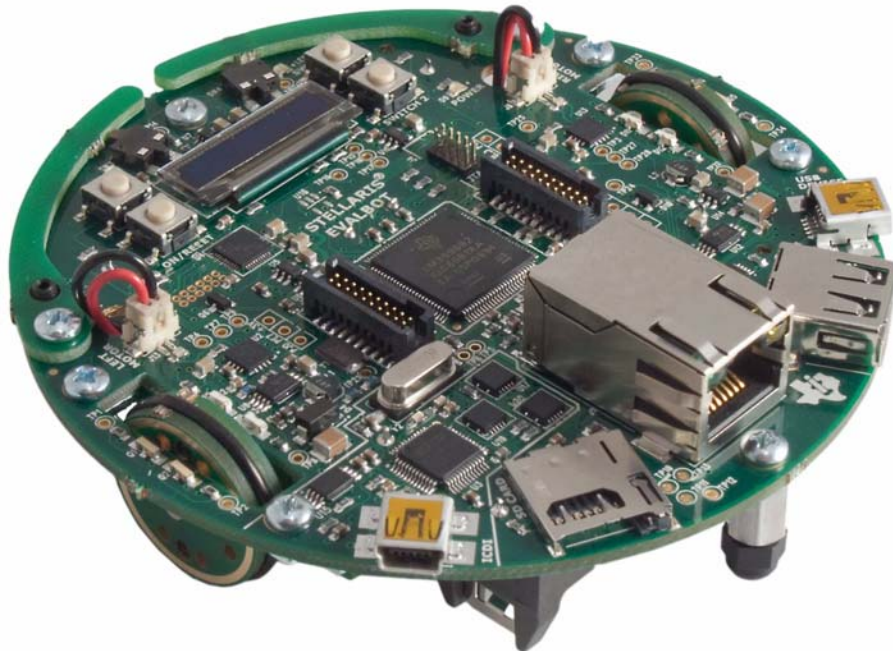

When roaming, three AA batteries supply power to the EVALBOT. The EVALBOT automatically selects USB power when tethered to a PC as a USB device or when debugging. Test points are provided to all key EVALBOT signals. Two 20-pin headers enable future wireless communications using standardized Texas Instruments' low-power embedded radio modules (EM boards). Additional uncommitted microcontroller signals are available on break-out pads arranged in rows adjacent to the microcontroller.

The EVALBOT has factory-installed quickstart software resident in on-chip Flash memory. For software debugging and Flash programming, an integrated In-Circuit Debug Interface (ICDI) requires only a single USB cable for debug and serial port functions.

Features

The EVALBOT board includes the following features:

- Evaluation board with robotic capabilities
- Mechanical components assembled by user

- Stellaris® LM3S9B92-IQC80 microcontroller
- MicroSD card connector
- I²S audio codec with speaker
- USB Host and Device connectors
- RJ45 Ethernet connector
- Bright 96 x 6 Blue OLED display
- On-board In-Circuit Debug Interface (ICDI)
- Battery power (3 AA batteries) or power through USB
- Wireless communication expansion port
- Robot features
 - Two DC gear-motors provide drive and steering
 - Opto-sensors detect wheel rotation with 45° resolution
 - Sensors for “bump” detection

Block Diagram

The EVALBOT evaluation board uses the Stellaris® LM3S9B92 microcontroller and includes a 10/100 Ethernet port and a USB 2.0 full-speed On-the-Go (OTG) port. The EVALBOT combines all mechanical and electrical components on a single circuit board. Figure 1-2 on page 11 shows a block diagram of the electrical section of the EVALBOT.

Figure 1-2. EVALBOT Block Diagram

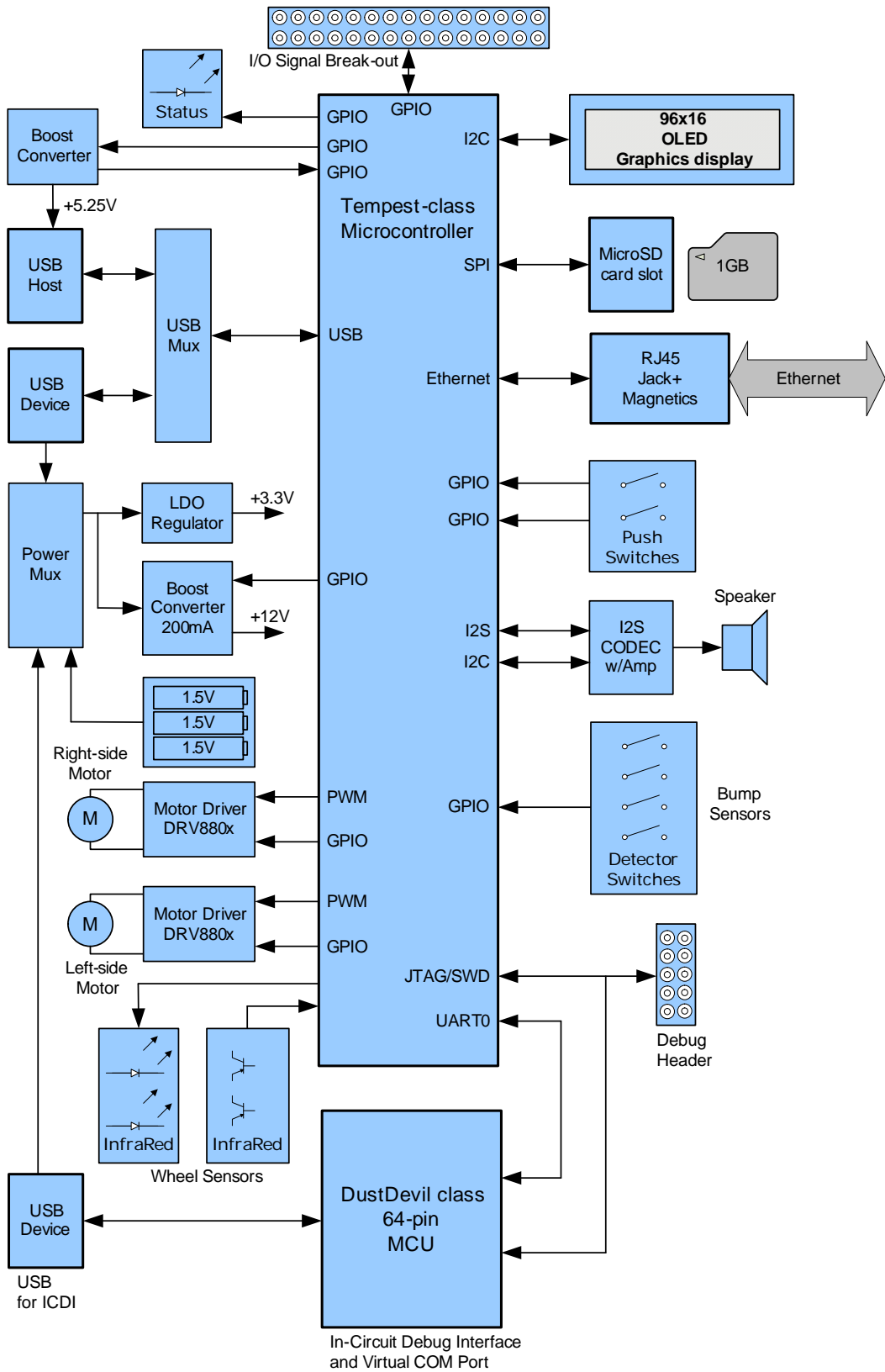

Specifications

Table 1-1 shows the specifications for the EVALBOT.

Table 1-1. EVALBOT Specifications

Parameter	Min	Typical	Max
Battery Supply Voltage	3.5 V	4.5 V	5.0 V
USB Supply Voltage	4.0 V	5.0 V	5.25 V
Battery current (typical stationary)	–	100 mA	–
Battery current (typical in motion)	–	200 mA	–
Power down supply current		0.5 μ A	
AA Alkaline Battery Capacity (typ)	–	2.5 A/Hr ^a	–
Reverse Battery Protection		No	
Allowable Battery/USB Current			0.5A

a. From Energizer E91 data sheet.

Hardware Description

The EVALBOT consists of a 4-inch diameter circuit board populated with a Stellaris LM3S9B92 microcontroller and 14 additional Texas Instruments analog and digital semiconductors.

LM3S9B92 Microcontroller

The Stellaris LM3S9B92 is an ARM® Cortex™-M3-based microcontroller with 256-KB flash memory, 96-KB SRAM, 80-MHz operation, Ethernet MAC/PHY, USB Host/Device/OTG, and a wide range of other peripherals. See the LM3S9B92 microcontroller data sheet (order number DS-LM3S9B92) for complete device details.

Unused microcontroller signals are routed to either the 20-pin EM expansion headers or to 0.1" pitch break-out pads which are labeled with their GPIO reference. An internal multiplexer allows different peripheral functions to be assigned to each of these GPIO pads. When adding external circuitry, consideration should be given to the additional load on the EVALBOT's power rails.

The reference design may include additional components necessary to address silicon errata. For details of those circuit functions, see the LM3S9B92 Errata document.

Clocking

The EVALBOT uses a 16.0-MHz crystal (Y3) to complete the LM3S9B92 microcontroller's main internal clock circuit. An internal PLL, configured in software, multiplies this clock to higher frequencies for core and peripheral timing.

A 25.0 MHz (Y1) crystal provides an accurate timebase for the Ethernet PHY.

Reset

The RESET signal into the LM3S9B92 microcontroller connects to the Reset/On switch (SW6) and to the ICDI circuit for a debugger-controlled reset.

External reset is asserted (active low) under any one of three conditions:

- Power-on reset (filtered by an R-C network)
- Reset/On push switch SW6 held down
- By the ICDI circuit when instructed by the debugger (this capability is optional, and may not be supported by all debuggers).

The OLED Module and Audio CODEC have special Reset timing requirements requiring a dedicated control line from the microcontroller.

Power Supplies

The EVALBOT can be powered either from batteries, the ICDI USB cable, or a USB device cable. The power source is determined by a Texas Instruments TPS2113 Auto Switching Power Mux and two Schottky diodes. Battery power is selected automatically when USB power is not present.

Table 2-1 shows the EVALBOT's power supplies. Each supply is generated directly or indirectly from the main power bus, +VS, using either a linear regulator or boost converter.

Table 2-1. EVALBOT Power Supplies

Name	Voltage	Max Current	Use
+VS	3.5 – 5.0 V	0.5 A	Main power distribution bus to other power rails
+3.3V	+3.3 V	150 mA	Logic power supply for main MCU, digital, and ICDI functions
+3.3VA	+3.3 V	150 mA	Analog and I/O power for audio CODEC
+1.8V	+1.8 V	25 mA	Digital/core power for audio CODEC
+5V_HVBUS	+5.25 V	100 mA	USB Host power supply
+12V	+12 V	100 mA	Motor driver power supply
+10V	+10 V	5 mA	OLED bias power supply

The board's on/off feature uses two push switches (SW5, SW6) and a simple feedback circuit through the inverter created by MOSFET Q3. An internal 1uA constant current source on the TPS2113's Enable pin (ENn) ensures that the TPS2113 is initially powered on when power is connected. Resistor R47 sets the overcurrent protection to 0.5 A.

Organic LED Display

The user interface consists of a 96 x 16 OLED display and two push switches. The OLED display has an integrated controller IC with a parallel, SPI, and I²C interfaces. In this design, the I²C interface is used. The OLED display is limited to 'write-only' in this mode, so pixel data cannot be read back from the display

microSD CARD

EVALBOT includes a microSD card interface, which interfaces to the MCU using a SPI interface. Because power to the SD card is not controlled removing or inserting the card while power is applied is not recommended.

Audio

A Texas Instruments TLV320AIC3107 CODEC adds a high performance audio stage to the EVALBOT. An integrated mono class-D amplifier drives an on-board speaker, with other audio inputs and outputs available on break-out header pads. An I2S interface carries the output (and input) audio data streams, while an I²C interface configures the CODEC. Most unused audio pins are available on nearby pads (0.05"pitch).

Ethernet

With its fully integrated 10/100 Ethernet MAC and PHY, the LM3S9B92 requires only a standard Jack with integrated magnetics and a few passive components. The TX and RX signals are routed to the jack as a differential pair. The PHY incorporates MDI/MDI-X cross-over, so the function of the TX and RX pairs can be swapped in software.

USB

The LM3S9B92 microcontroller has Host, Device, and OTG USB capabilities. EVALBOT supports USB Host and Device with dedicated connectors and a Texas Instruments T3USB30E high-speed USB multiplexer to select between them.

Robotic Features

Two 12-V gear motors provide locomotion to the EVALBOT. A Texas Instruments' DRV8801 Full-Bridge motor driver IC controls each motor; providing direction control, over-current and short-circuit protection, dead-time insertion and several switching schemes.

Each EVALBOT wheel has two infra-red optical sensors which generate a quadrature signal as the wheel rotates. The IR emitters (D2, D3, D11, and D12) each connect to a GPIO signal so that the MCU can turn off the LEDs for power saving when not in motion. The GPIO outputs should be configured for 8 mA drive-strength to ensure the IR emitters have sufficient intensity.

Left and right-side bumpers detect collisions using simple detector switches. The GPIO inputs should have internal pull-up resistors enabled and may optionally be configured to generate an interrupt when a collision occurs.

Expansion

The EM port on EVALBOT enables RF connectivity using a range of Low-Power RF Evaluation Modules (EM boards) from Texas Instruments. EM boards cover both Sub 1-GHz and 2.4GHz bands and are supported by a several different protocol stacks.

The EM port can also be used for general purpose expansion. SPI, UART, and GPIO signals are available. Table 2-2 lists the connector part numbers. Two identical connectors should be installed on a 1.20" pitch.

Table 2-2. Connector Part Numbers

Supplier	Part Number	Description	Use
Samtec	TFM-110-02-S-D	SMT Header 20-pos 0.050" pitch	EVALBOT EM port
Samtec	SFM-110-02-S-D	SMT Socket 20-pos 0.050" pitch	EM board

In addition to the EM port, EVALBOT also has 9 GPIO (PJ0..7, PE7), Power and GND connections on a 0.1" grid.

Debugging

EVALBOT includes an integrated In-Circuit Debug Interface (ICDI) for debugging, serial communication and power over a single USB cable. Based on an FTDI FT2232 USB controller, the ICDI supports all major Cortex-M3 development environments.

Stellaris microcontrollers support programming and debugging using either JTAG or SWD. JTAG uses the signals TCK, TMS, TDI, and TDO. SWD requires fewer signals (SWCLK, SWDIO, and, optionally, SWO for trace). The debugger determines which debug protocol is used.

An external debug interface can be used with EVALBOT if connector J4 is installed by the user.

JTAG/SWD

The FT2232 is factory-configured by Texas Instruments to implement a JTAG/SWD port (synchronous serial) on channel A and a Virtual COM Port (VCP) on channel B. This feature

allows two simultaneous communications links between the host computer and the target device using a single USB cable. Separate Windows drivers for each function are provided on the Documentation and Software CD.

The In-Circuit Debug Interface USB capabilities are completely independent from the LM3S9B92's on-chip USB functionality.

A small serial EEPROM holds the FT2232 configuration data. The EEPROM is not accessible by the LM3S9B92 microcontroller. For full details on FT2232 operation, go to www.ftdichip.com.

The FT2232 USB device performs JTAG/SWD serial operations under the control of the debugger. A simple logic circuit multiplexes SWD and JTAG functions and, when working in SWD mode, provides direction control for the bidirectional data line.

Virtual COM Port

The Virtual COM Port (VCP) allows Windows applications (such as HyperTerminal) to communicate with UART0 on the LM3S9B92 over USB. Once the FT2232 VCP driver is installed, Windows assigns a COM port number to the VCP channel.

Serial Wire Out

EVALBOT also supports the Cortex-M3 Serial-Wire Output (SWO) trace capabilities. Under debugger control, on-board logic can route the SWO data stream to the VCP transmit channel. The debugger software can then decode and interpret the trace information received from the Virtual Com Port. The normal VCP connection to UART0 is interrupted when using SWO. Not all debuggers support SWO.

See the *Stellaris LM3S9B92 Microcontroller Data Sheet* for additional information on the Trace Port Interface Unit (TPIU).

Schematics

Schematics for the EVALBOT board follow.

- Microcontroller, Ethernet, and USB on page 18
- Wheel Encoders, Motor Drivers, and Bumper Switches on page 19
- User Interface, Audio, SD Card on page 20
- Power Supplies on page 21
- In-Circuit Debug Interface on page 22

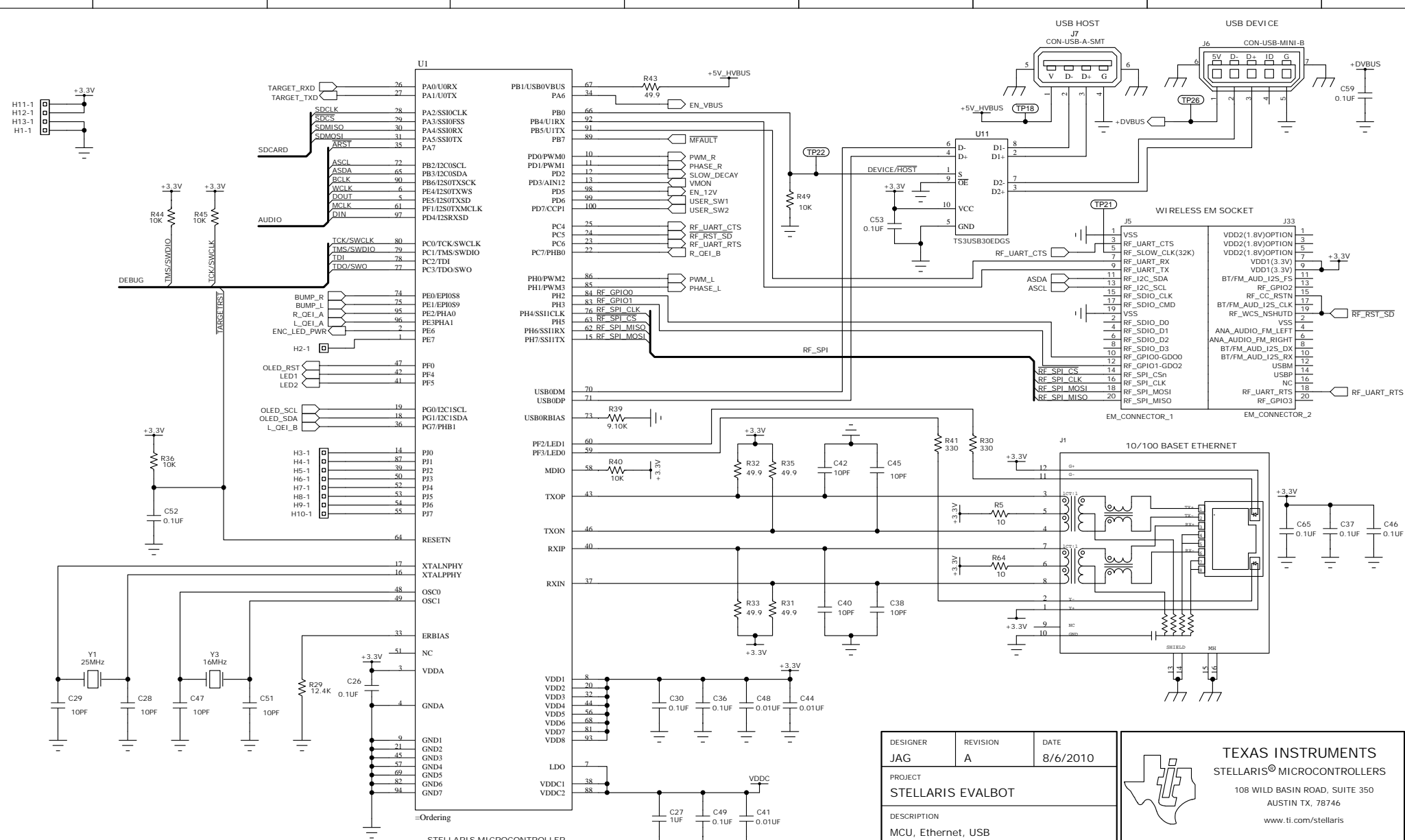

DESIGNER	REVISION	DATE
JAG	A	8/6/2010
PROJECT		
STELLARIS EVALBOT		
DESCRIPTION		
MCU, Ethernet, USB		
FILENAME		
EvalBot Rev A.sch		

TEXAS INSTRUMENTS
STELLARIS[®] MICROCONTROLLERS

108 WILD BASIN ROAD, SUITE 350
AUSTIN TX, 78746
www.ti.com/stellaris

PART NO.	EK-EVALBOT-A	SHEET	1 OF 5
----------	--------------	-------	--------

STELLARIS MICROCONTROLLER

=Ordering

RIGHT-WHEEL ENCODER

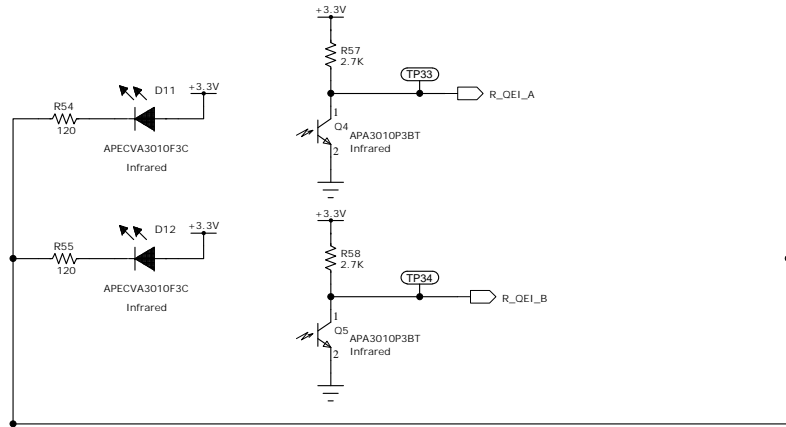

LEFT-WHEEL ENCODER

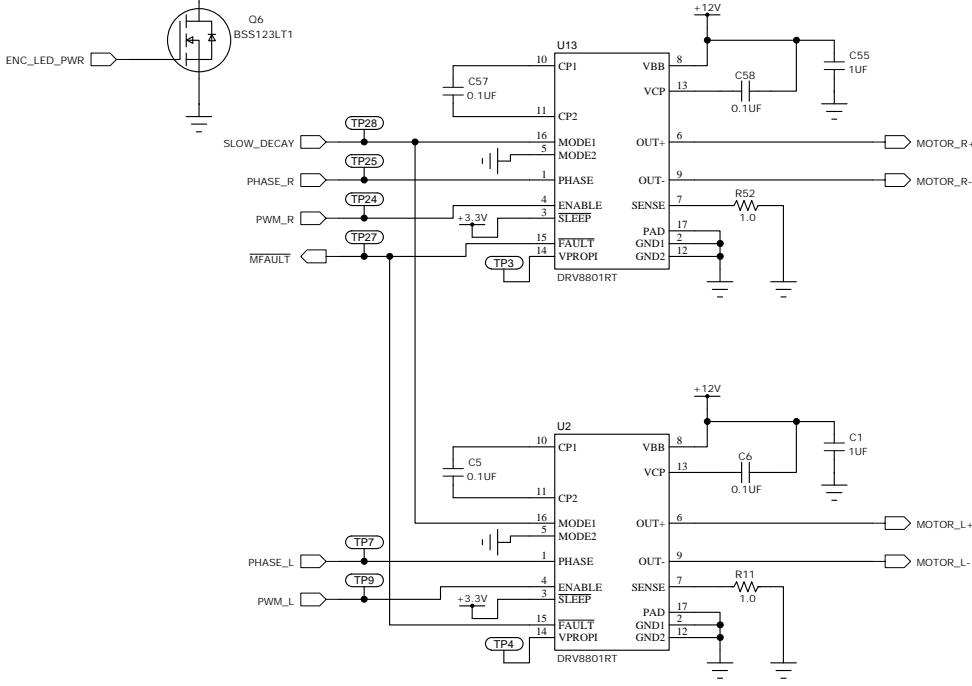
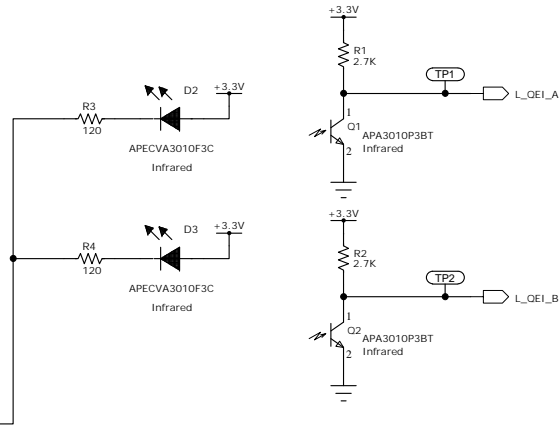

MOTOR TERMINALS

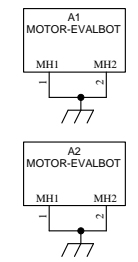
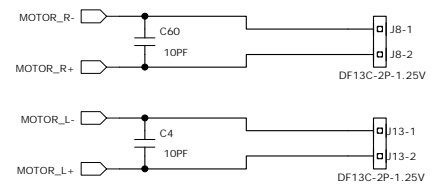

BUMPER SWITCHES

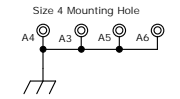
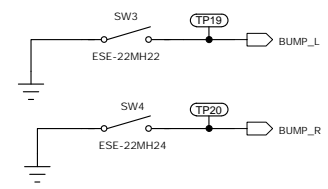

DESIGNER	REVISION	DATE
JAG	A	8/6/2010
PROJECT		
STELLARIS EVALBOT		
DESCRIPTION		
?DESC1?		
?DESC2?		
FILENAME	EvalBot Rev A.sch	

TEXAS INSTRUMENTS
STELLARIS[®] MICROCONTROLLERS
 108 WILD BASIN ROAD, SUITE 350
 AUSTIN TX, 78746
www.ti.com/stellaris

PART NO.	EK-EVALBOT-A	SHEET	2 OF 5
----------	--------------	-------	--------

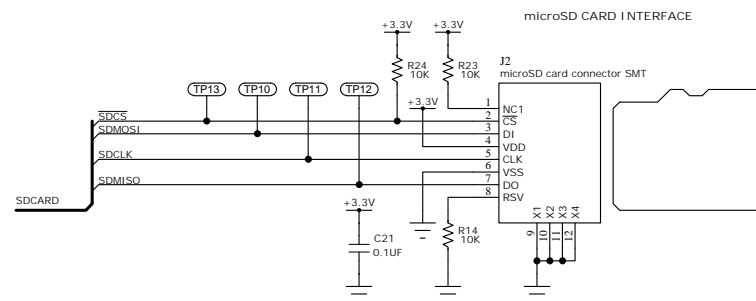
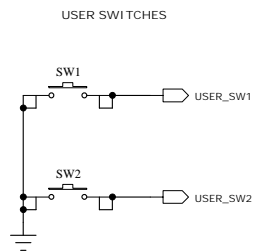
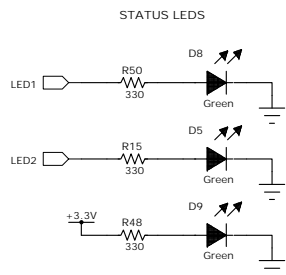
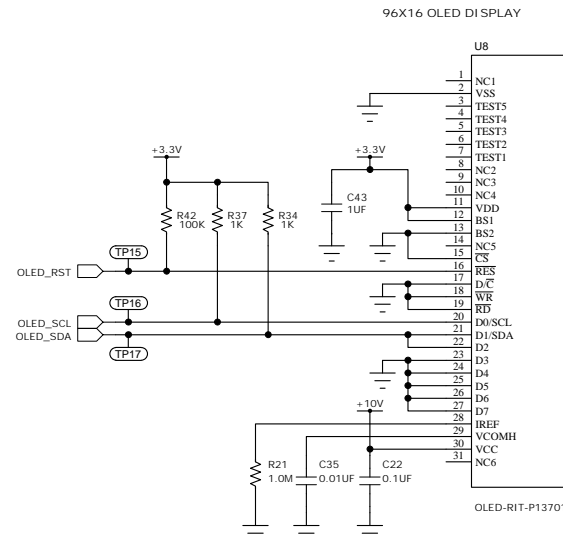
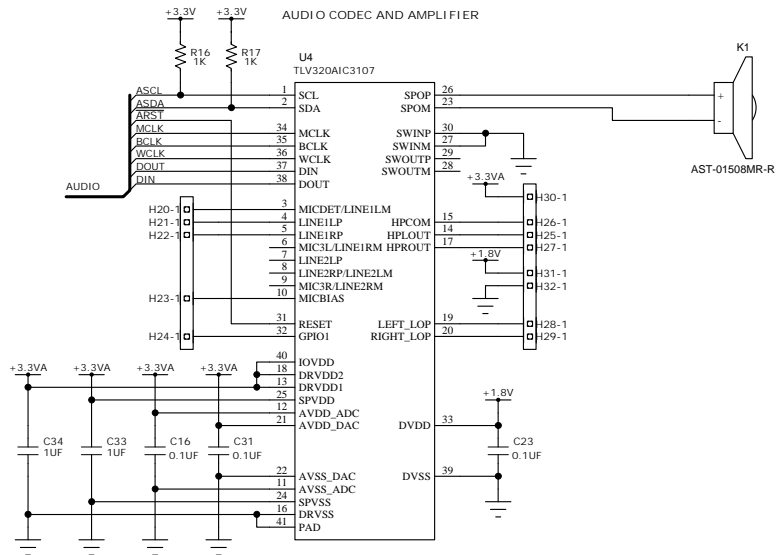

DESIGNER	REVISION	DATE
JAG	A	8/6/2010
PROJECT		
STELLARIS EVALBOT		
DESCRIPTION		
USER INTERFACE, AUDIO, SD CARD		
FILENAME	EvalBot Rev A.sch	

	TEXAS INSTRUMENTS STELLARIS [®] MICROCONTROLLERS	
	108 WILD BASIN ROAD, SUITE 350 AUSTIN TX, 78746 www.ti.com/stellaris	
PART NO.	EK-EVALBOT-A	SHEET
		3 OF 5

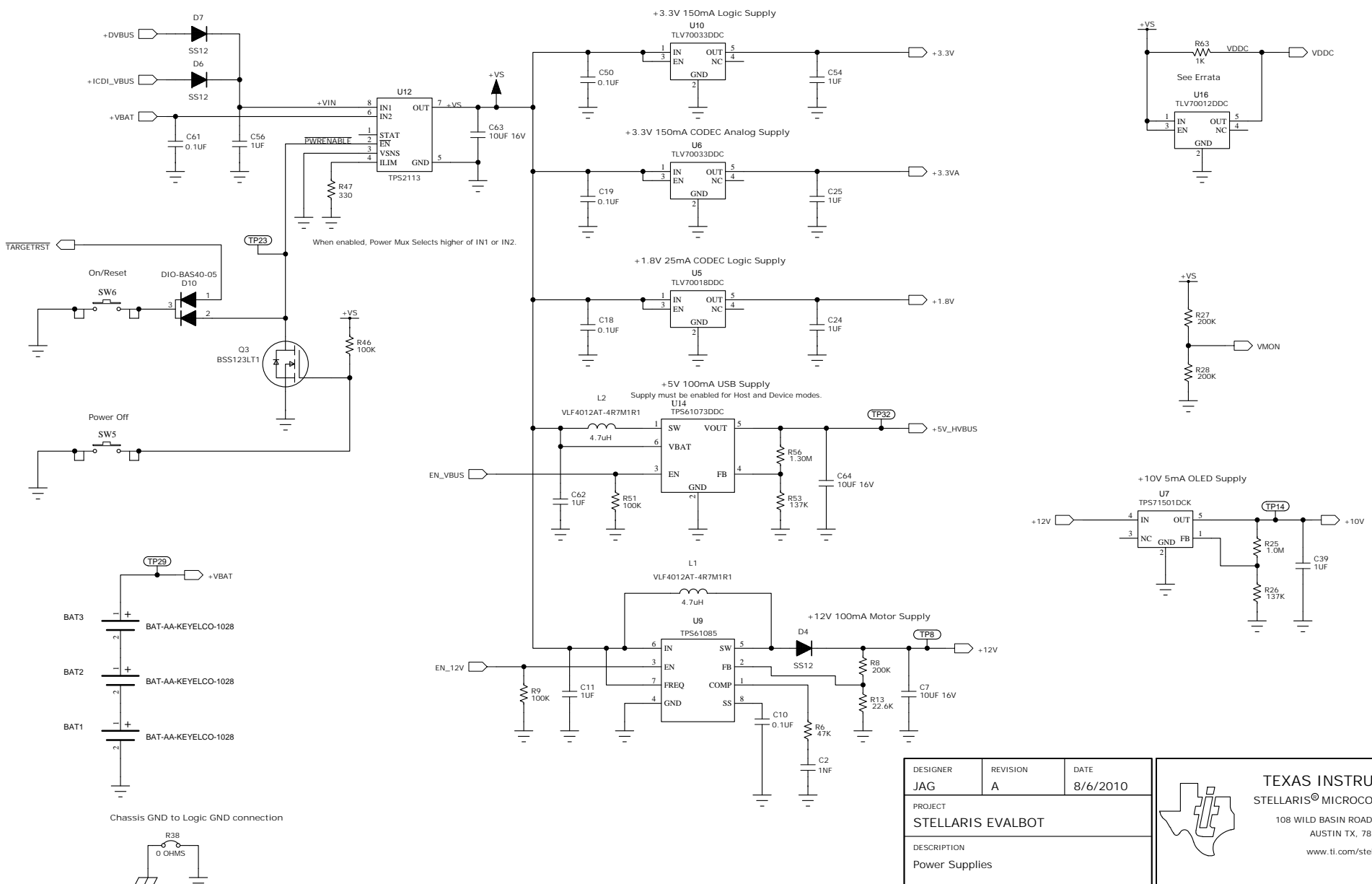

DESIGNER	REVISION	DATE
JAG	A	8/6/2010
PROJECT		
STELLARIS EVALBOT		
DESCRIPTION		
Power Supplies		
FILENAME	EvalBot Rev A.sch	

	TEXAS INSTRUMENTS STELLARIS [®] MICROCONTROLLERS	
	108 WILD BASIN ROAD, SUITE 350 AUSTIN TX, 78746 www.ti.com/stellaris	
	PART NO.	EK-EVALBOT-A
	SHEET	4 OF 5

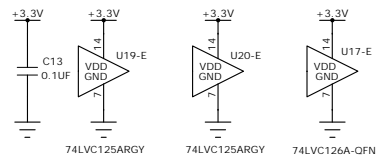
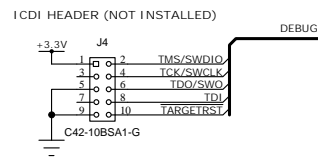
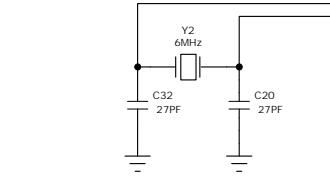
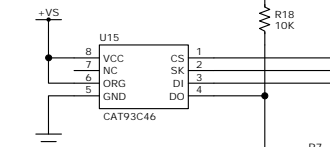
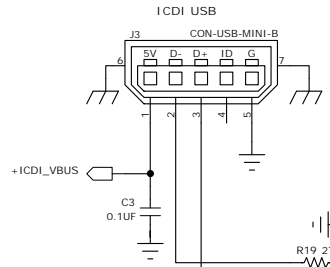
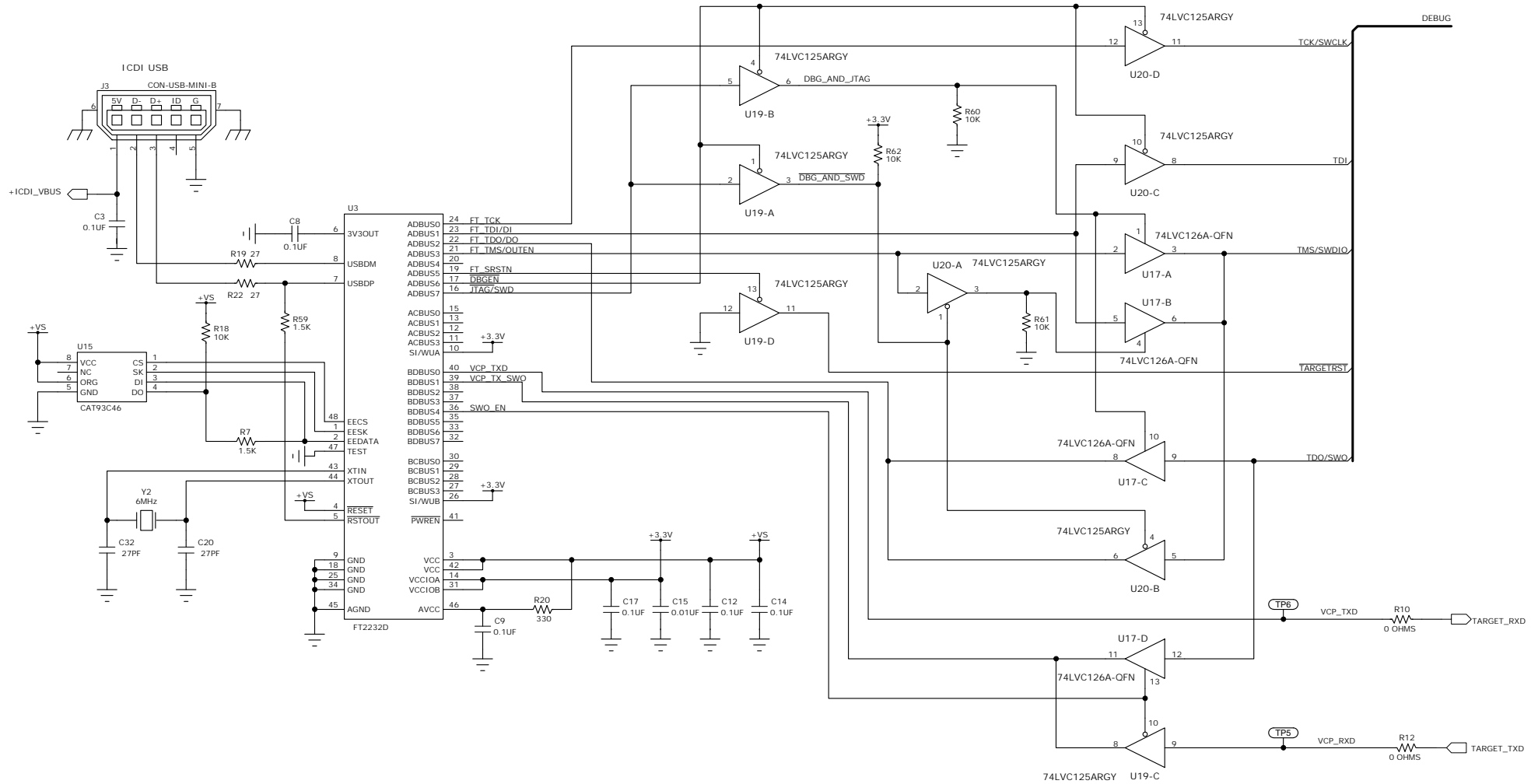

DESIGNER JAG	REVISION A	DATE 8/6/2010
PROJECT STELLARIS EVALBOT		
DESCRIPTION In-Circuit Debug Interface		
FILENAME EvalBot Rev A.sch		

	TEXAS INSTRUMENTS	
	STELLARIS [®] MICROCONTROLLERS	
	108 WILD BASIN ROAD, SUITE 350 AUSTIN TX, 78746	
	www.ti.com/stellaris	
PART NO. EK-EVALBOT-A	SHEET 5 OF 5	

APPENDIX B

Component Locations

Plots of the top-side and bottom-side component locations are shown in Figure B-1. Complete Gerber (RS274X) and PCB (Mentor PADS) files for the four-layer PCB layout are included in the EVALBOT Board Hardware Package.

Figure B-1. EVALBOT Component Locations

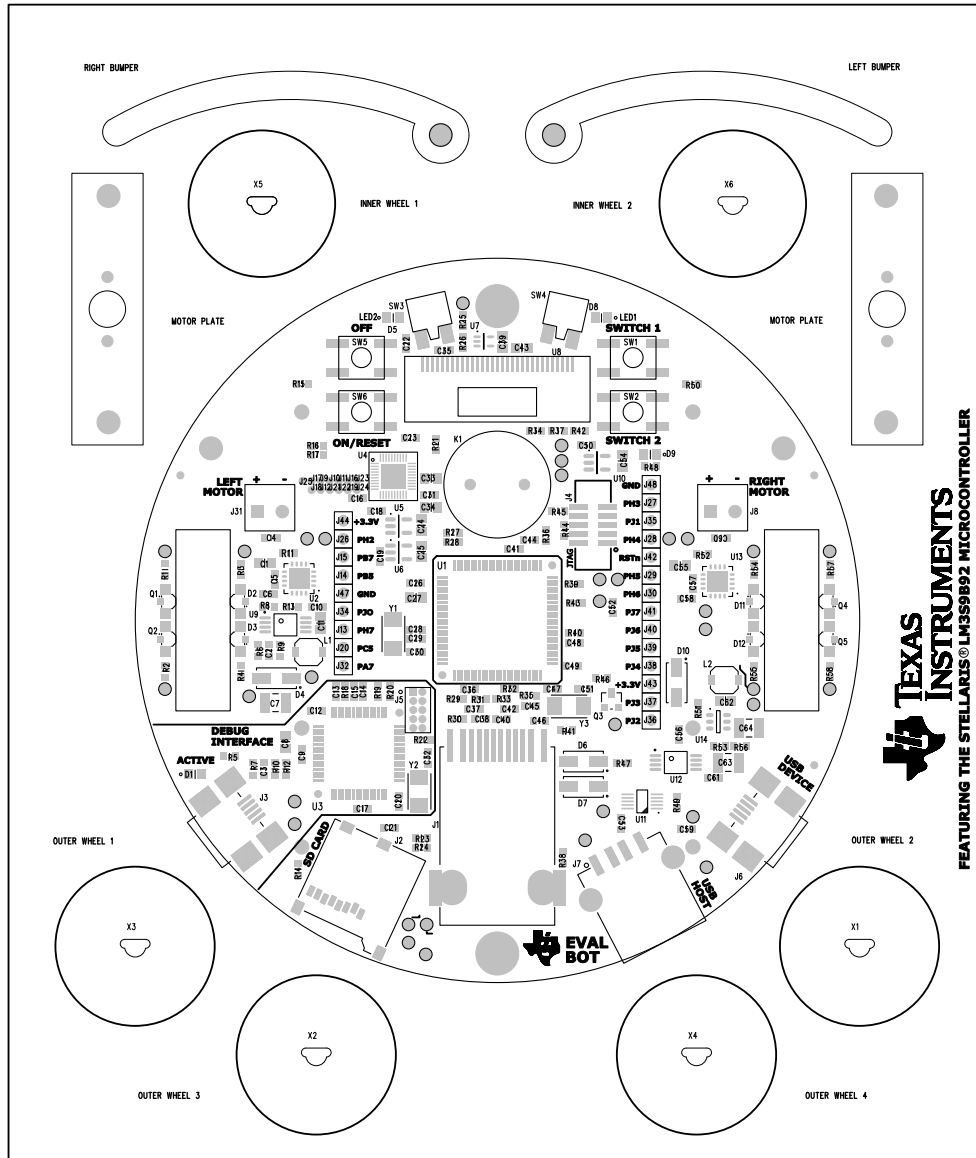

A P P E N D I X C

Bill of Materials (BOM)

Table C-1. shows the Bill of Materials for the EVALBOT board design.

Table C-1. EVALBOT Bill of Materials (BOM)

Item	Reference	Qty	Part Number	Description	Mfg
1	BAT1-3	3	1028	Compact AA Battery holder, through-hole	Keystone
2	C1 C11 C24-25 C27 C33-34 C39 C43 C54 C55 C56 C62	13	C2012X5R1E105K	Capacitor, 1.0uF 25V 10% X5R 0805	TDK
3	C15 C35 C41 C44 C48	5	C0603C103J5RACTU	Capacitor, 0.01uF 50V 5% 0603 X7R	Kemet
4	C2	1	C0603C102J5RACTU	Capacitor , 0.001uF 50V 5% 0603 X7R	Kemet
5	C3 C5-6 C8-10 C12-14 C16-19 C21-23 C26 C30-31 C36-37 C46 C49-50 C52-53 C57-59 C61 C65	31	GRM188R71H104KA 93D	Capacitor, 0.1uF 50V 10% 0603 X7R	TDK
6	C4 C28-29 C38 C40 C42 C45 C47 C51 C60	10	C0603C100J5GACTU	Capacitor 10pF 50V 5% Ceramic NPO/COG 0603	Kemet
7	C20 C32	2	C0603C270J5GACTU	Capacitor 27pF 50V 5% Ceramic NPO/COG 0603	Kemet
8	C7 C63-64	3	C3225X5R1C106M	Capacitor, 10uF 16V 20% X5R 1210	TDK
9	D5 D8-9	3	LTST-C171GKT	LED, 0805 SMT Green	LiteOn
10	D2-3 D11-12	4	APECVA3010F3C	LED, Infrared, Right Angle in 3.0 x 1.0mm SMT	Kingbright
11	D4 D6-7	4	SS12	Diode, Schottky 20V 1A SMA	Taiwan Semi
12	D10	1	BAS40-05-7-F	Diode, Schottky 40V 100mA SOT23	Diodes
13	J1	1	HR961160C J3011G21DNL J3011G21DNLT	Connector, RJ45 with 10/100 magnetics, shielded SMT	Hanrun Pulse
14	J2	1	2908-05WB-MG	Connector, Micro SD card, push-push SMT	3M
15	J3 J6	2	54819-0572	Connector, USB Mini-B SMT 5pin	Molex
16	J7	1	AU-Y1006-R 154-UAR42-E	Connector, USB Type A	Assmann Kobiconn

Table C-1. EVALBOT Bill of Materials (BOM) (Continued)

Item	Reference	Qty	Part Number	Description	Mfg
17	J8 J13	2	DF13C-2P-1.25V(20)	Connector, Header 2 pos, 1.25mm SMD Tin	Hirose
18	K1	1	AST-01508MR-R	Speaker, 8 ohm 0.3W 15mm PCB mount	Projects Unlimited
19	L1-2	2	VLF4012AT-4R7M1R 1	Inductor 3.7x3.5 SMT 1.1A	TDK
20	Q1-2 Q4-5	4	APA3010P3BT	Phototransistor, Infrared, Right Angle in 3.0 x 1.0mm SMT	Kingbright
21	Q3 Q6	2	BSS123LT1	MOSFET, N-Channel 100V 170mA SOT-23	On Semi
22	R11 R52	2		Resistor 1 ohms 1% 0603	Generic
23	R19, R22	2		Resistor 27 ohms 5% 0603	Generic
24	R1-2 R57-58	4		Resistor 4.7K 5% 0603	Generic
25	R13	1		Resistor 22.6K 1% 0603	Generic
26	R14 R18 R23-24 R36 R40 R44-45 R49 R60-62	12		Resistor 10K 5% 0606	Generic
27	R39	1		Resistor 9.10K 1% 0603	Generic
28	R21 R25	2		Resistor 1.0M 1% 0603	Generic
29	R26 R53	2		Resistor 137K 1% 0603	Generic
30	R29	1		Resistor 12.4K 1% 0603	Generic
31	R5, R64	2		Resistor, 10 ohms 5% 0603	Generic
32	R31-33 R35 R43	5		Resistor 49.9 ohms 1% 0603	Generic
33	R3-4 R54-55	4		Resistor 120 ohms 1% 0603	Generic
34	R10, R12, R38	3		Resistor 0 ohms 0603	Generic
35	R16-17 R34 R37 R47 R63	6		Resistor 1K 5% 0603	Generic
36	R7, R59	2		Resistor 1.5K 5% 0603	Generic
37	R15 R20 R30 R41 R48 R50	6		Resistor 330 ohms 5% 0603	Generic
38	R56	1		Resistor 1.30M 1% 0603	Generic
39	R6	1		Resistor 47K 5% 0603	Generic
40	R8 R27-28	3		Resistor 200K 1% 0603	Generic
41	R9 R42 R46 R51	4		Resistor 100K 1% 0603	Generic
42	SW3	1	ESE-22MH22	Switch, Detector-style Horizontal - Right/top actuation	Panasonic

Table C-1. EVALBOT Bill of Materials (BOM) (Continued)

Item	Reference	Qty	Part Number	Description	Mfg
43	SW4	1	ESE-22MH24	Switch, Detector-style Horizontal - Left/top actuation	Panasonic
44	SW1-2 SW5-6	2	EVQ-Q2B02W	Switch, Tact 6mm SMT, 50gf	Panasonic
45	U3	1	FT2232D	IC, USB to Serial Interface TQFP48	Ftdi
46	U15	1	CAT93C46YI-G / AT93C46A-10TU-2.7	IC, Serial Eeprom 1Kbit TSSOP8	Catalyst Atmel
47	Y1	1	NX5032GA-25.00000 0MHZ 8B48-25.000MHZ TR	Crystal, 25.00MHz 5.0x3.2mm SMT	NDK Suntsu
48	Y2	1	FOXSDLF/060-20	Crystal, 6.00MHz HC49US SMT	Fox
49	Y3	1	NX5032GA-16.00000 0MHZ	Crystal, 16.00MHz 5.0x3.2mm SMT	tbd
50	J5 J33	2	TFM-110-02-S-D-K-A	Connector, 20 pos 1.27mm pitch, SMT	Samtec
51	U1	1	LM3S9B92-IQC80	IC, ARM Cortex-M3 Microcontroller TQFP100	TI
52	U2 U13	2	DRV8801RTY	IC, Full-Bridge Motor Driver	TI
53	U4	1	TLV320AIC3107IRSB R	IC, Audio CODEC with class D amplifier WQFN	TI
54	U5	1	TLV70018DDCT	IC, 1.8V 200mA Low-dropout voltage regulator	TI
55	U6 U10	2	TLV70033DDCT	IC, 3.3V 200mA Low-dropout voltage regulator	TI
56	U7	1	TPS71501DCKR	IC, Adjustable 50mA Low-dropout voltage regulator, SC70	TI
57	U8	1	RGS08096016BW00 1	OLED display, 96x16 Blue 13701	RiT
58	U9	1	TPS61085PWR	IC, Step-up DC-DC Converter	TI
59	U11	1	TS3USB30EDGSR	IC, High Speed USB 2.0 1:2 Mux/Demux Switch SSOP	TI
60	U12	1	TPS2113PW	IC, 2-Ch Auto-switching power mux	TI
61	U14	1	TPS61073DDC	IC, Synchronous Boost Converter with 600-mA switch	TI
62	U17	1	SN74LVC126ARGY	IC, Quad tri-state line driver act lo TSSOP14	TI
63	U19 U20	2	SN74LVC125ARGY	IC, Quad tri-state line driver act hi TSSOP14	TI
64	PCB1	1	PCB-EVALBOT-A	PCB, 4-layer 5.200x6.850"	
65	LABEL1	1	LABEL-EVALBOT	Label, 2.90" x 0.50" 'Learn more at www.ti.com/EvalBot '. Place on robot underside.	

References

In addition to this document, the following references are available for download at www.ti.com/stellaris.

- *Stellaris LM3S9B92 Microcontroller Data Sheet*
- *Stellaris LM3S5632 Microcontroller Data Sheet*
- *DMOS Full-Bridge Motor Drivers Data Sheet (DRV8801RTY)*
- *Low-Power Stereo CODEC with Integrated Mono Class-D Amplifier Data Sheet (TLV320AIC3107)*
- *200mA, Low IQ, Low Dropout Regulator for Portables Data Sheet (TLV70018)*
- *200mA, Low IQ, Low Dropout Regulator for Portables Data Sheet (TLV70033)*
- *50mA, 24V, 3.2- μ A Supply Current, Low-Dropout Linear Regulator in SC70 Package Data Sheet (TPS71501)*
- *650 kHz/1.2MHz Step-Up DC-DC Converter w/ Forced PWM Mode Data Sheet (TPS61085)*
- *High-Speed USB 2.0 (480 Mbps) 1:2 Multiplexer/Demultiplexer Switch With Single Enable Data Sheet (TS3USB30)*
- *Dual In/Single Out Autoswitching Power MUX Data Sheet (TPS2113)*
- *Adjustable, 600-mA Switch, 90% Efficient PFM/PWM Boost Converter in ThinSOT Data Sheet (TPS61073)*
- The following data sheets can be obtained from the manufacturer:
- *P13701 OLED Display Data Sheet from RiT Display Corporation*
- *SSD1300 OLED Controller Data Sheet from Solomon Systech Limited*

IMPORTANT NOTICE

Texas Instruments Incorporated and its subsidiaries (TI) reserve the right to make corrections, modifications, enhancements, improvements, and other changes to its products and services at any time and to discontinue any product or service without notice. Customers should obtain the latest relevant information before placing orders and should verify that such information is current and complete. All products are sold subject to TI's terms and conditions of sale supplied at the time of order acknowledgment.

TI warrants performance of its hardware products to the specifications applicable at the time of sale in accordance with TI's standard warranty. Testing and other quality control techniques are used to the extent TI deems necessary to support this warranty. Except where mandated by government requirements, testing of all parameters of each product is not necessarily performed.

TI assumes no liability for applications assistance or customer product design. Customers are responsible for their products and applications using TI components. To minimize the risks associated with customer products and applications, customers should provide adequate design and operating safeguards.

TI does not warrant or represent that any license, either express or implied, is granted under any TI patent right, copyright, mask work right, or other TI intellectual property right relating to any combination, machine, or process in which TI products or services are used. Information published by TI regarding third-party products or services does not constitute a license from TI to use such products or services or a warranty or endorsement thereof. Use of such information may require a license from a third party under the patents or other intellectual property of the third party, or a license from TI under the patents or other intellectual property of TI.

Reproduction of TI information in TI data books or data sheets is permissible only if reproduction is without alteration and is accompanied by all associated warranties, conditions, limitations, and notices. Reproduction of this information with alteration is an unfair and deceptive business practice. TI is not responsible or liable for such altered documentation. Information of third parties may be subject to additional restrictions.

Resale of TI products or services with statements different from or beyond the parameters stated by TI for that product or service voids all express and any implied warranties for the associated TI product or service and is an unfair and deceptive business practice. TI is not responsible or liable for any such statements.

TI products are not authorized for use in safety-critical applications (such as life support) where a failure of the TI product would reasonably be expected to cause severe personal injury or death, unless officers of the parties have executed an agreement specifically governing such use. Buyers represent that they have all necessary expertise in the safety and regulatory ramifications of their applications, and acknowledge and agree that they are solely responsible for all legal, regulatory and safety-related requirements concerning their products and any use of TI products in such safety-critical applications, notwithstanding any applications-related information or support that may be provided by TI. Further, Buyers must fully indemnify TI and its representatives against any damages arising out of the use of TI products in such safety-critical applications.

TI products are neither designed nor intended for use in military/aerospace applications or environments unless the TI products are specifically designated by TI as military-grade or "enhanced plastic." Only products designated by TI as military-grade meet military specifications. Buyers acknowledge and agree that any such use of TI products which TI has not designated as military-grade is solely at the Buyer's risk, and that they are solely responsible for compliance with all legal and regulatory requirements in connection with such use.

TI products are neither designed nor intended for use in automotive applications or environments unless the specific TI products are designated by TI as compliant with ISO/TS 16949 requirements. Buyers acknowledge and agree that, if they use any non-designated products in automotive applications, TI will not be responsible for any failure to meet such requirements.

Following are URLs where you can obtain information on other Texas Instruments products and application solutions:

Products		Applications	
Amplifiers	amplifier.ti.com	Audio	www.ti.com/audio
Data Converters	dataconverter.ti.com	Automotive	www.ti.com/automotive
DLP® Products	www.dlp.com	Communications and Telecom	www.ti.com/communications
DSP	dsp.ti.com	Computers and Peripherals	www.ti.com/computers
Clocks and Timers	www.ti.com/clocks	Consumer Electronics	www.ti.com/consumer-apps
Interface	interface.ti.com	Energy	www.ti.com/energy
Logic	logic.ti.com	Industrial	www.ti.com/industrial
Power Mgmt	power.ti.com	Medical	www.ti.com/medical
Microcontrollers	microcontroller.ti.com	Security	www.ti.com/security
RFID	www.ti-rfid.com	Space, Avionics & Defense	www.ti.com/space-avionics-defense
RF/IF and ZigBee® Solutions	www.ti.com/lprf	Video and Imaging	www.ti.com/video
		Wireless	www.ti.com/wireless-apps