



# M20

## Quectel Cellular Engine

### Hardware Design

M20\_HD\_V1.01



<b>Document Title</b>	M20 Hardware Design
<b>Revision</b>	1.01
<b>Date</b>	2009-09-17
<b>Status</b>	Release
<b>Document Control ID</b>	M20_HD_V1.01

### **General Notes**

Quectel offers this information as a service to its customers, to support application and engineering efforts that use the products designed by Quectel. The information provided is based upon requirements specifically provided to Quectel by the customers. Quectel has not undertaken any independent search for additional relevant information, including any information that may be in the customer's possession. Furthermore, system validation of this product designed by Quectel within a larger electronic system remains the responsibility of the customer or the customer's system integrator. All specifications supplied herein are subject to change.

### **Copyright**

This document contains proprietary technical information which is the property of Quectel Limited., copying of this document and giving it to others and the using or communication of the contents thereof, are forbidden without express authority. Offenders are liable to the payment of damages. All rights reserved in the event of grant of a patent or the registration of a utility model or design. All specification supplied herein are subject to change without notice at any time.

*Copyright © Quectel Wireless Solutions Co., Ltd. 2009*

## Contents

0 Revision history .....	8
1 Introduction .....	9
1.1 Related documents .....	9
1.2 Terms and abbreviations .....	10
1.3 Safety caution .....	12
2 Product concept .....	14
2.1 Key features .....	14
2.2 Functional diagram .....	16
2.3 Evaluation board .....	17
3 Application interface .....	18
3.1 Pin description .....	18
3.2 Operating modes .....	22
3.3 Power supply .....	23
3.3.1 Power supply pins .....	25
3.3.2 Minimizing power losses .....	25
3.3.3 Monitoring power supply .....	26
3.4 Power up and power down scenarios .....	26
3.4.1 Turn on .....	26
3.4.2 Turn off .....	29
3.4.3 Restart module using the PWRKEY pin .....	32
3.5 Charging interface .....	33
3.5.1 Battery pack characteristics .....	34
3.5.2 Recommended battery pack .....	35
3.5.3 Implemented charging technique .....	36
3.5.4 Operating modes during charging .....	38
3.5.5 Charger requirements .....	39
3.6 Power saving .....	40
3.6.1 Minimum functionality mode .....	40
3.6.2 SLEEP mode .....	40
3.6.3 Wake up module from the SLEEP mode .....	41
3.7 Summary of state transition (except SLEEP mode) .....	41
3.8 RTC backup .....	41
3.9 Serial interface .....	43
3.9.1 Function of serial port 0 & serial port 1 .....	45
3.9.2 Software upgrade and software debug .....	46
3.10 Audio interfaces .....	48
3.10.1 Microphone interface configuration .....	49
3.10.2 Speaker interface configuration .....	51
3.10.3 Earphone interface configuration .....	53
3.10.4 DAI interface (optional) .....	54
3.11 SIM card interface .....	55

3.11.1 SIM card application .....	55
3.11.2 Design considerations for SIM card holder .....	57
3.12 ADC.....	59
3.13 Behavior of the pin RI0.....	59
3.14 Network status indication.....	61
4 Antenna interface .....	62
4.1 Antenna installation.....	62
4.1.1 Antenna connector.....	62
4.1.2 Antenna pad.....	63
4.2 RF output power.....	64
4.3 RF receiving sensitivity.....	64
4.4 Operating frequency.....	64
5 Electrical, reliability and radio characteristics .....	65
5.1 PIN assignment of the module .....	65
5.2 Absolute maximum ratings.....	66
5.3 Operating temperatures .....	66
5.4 Power supply ratings .....	66
5.5 Current consumption .....	67
5.6 Electro-static discharge .....	70
6 Product information .....	71
7 Mechanical dimension .....	72
7.1 Mechanical dimensions of module.....	72
7.2 Footprint of recommendation.....	73
7.3 Mounting module in the host .....	73
7.3.1 Board-to-board connector.....	74
7.3.2 Mechanical dimensions of the DF12 header (without metal fitting).....	74
7.3.3 Physical photo of the DF12 connector .....	75
7.4 RF connector .....	76
7.4.1 Physical photo of the UFL-R-SMT connector.....	76
7.4.2 Matching connector on the application side of M20 .....	76
7.4.3 Space factor of mated connector .....	77
7.5 Top view of the module .....	78
7.6 Bottom view of the module.....	78
Appendix A: GPRS Coding Schemes .....	79
Appendix B: GPRS Multi-slot Classes .....	80

## Table Index

TABLE 1: RELATED DOCUMENTS .....	9
TABLE 2: TERMS AND ABBREVIATIONS .....	10
TABLE 3: MODULE KEY FEATURES.....	14
TABLE 4: CODING SCHEMES AND MAXIMUM NET DATA RATES OVER AIR INTERFACE..	16
TABLE 5: PIN DESCRIPTION .....	18
TABLE 6: OVERVIEW OF OPERATING MODES.....	22
TABLE 7: RECOMMENDED BYPASS CAPACITORS FOR LIMITED CURRENT SUPPLY.....	25
TABLE 8: AT COMMANDS USED IN ALARM MODE .....	29
TABLE 9: RECOMMENDED BATTERY PROTECT CIRCUIT PARAMETER.....	35
TABLE 10: SPECIFICATION OF THE RECOMMENDED BATTERY PACK.....	35
TABLE 11: OPERATING MODES.....	39
TABLE 12: AT COMMANDS AVAILABLE IN THE GHOST MODE .....	39
TABLE 13: SUMMARY OF STATE TRANSITION.....	41
TABLE 14: LOGIC LEVELS OF SERIAL PORT.....	45
TABLE 15: PIN DEFINITION OF SERIAL INTERFACE .....	45
TABLE 16: PIN DEFINITION OF AUDIO INTERFACE .....	48
TABLE 17: TYPICAL ELECTRET MICROPHONE INPUT CHARACTERISTIC .....	53
TABLE 18: TYPICAL SPEAKER OUTPUT CHARACTERISTIC.....	54
TABLE 19: PIN DEFINITION OF THE DAI INTERFACE .....	54
TABLE 20: PIN DEFINITION OF THE SIM INTERFACE .....	55
TABLE 21: PIN DESCRIPTION (AMPHENOL SIM CARD HOLDER) .....	58
TABLE 22: PIN DESCRIPTION (MOLEX SIM CARD HOLDER) .....	58
TABLE 23: PIN DEFINITION OF THE ADC.....	59
TABLE 24: CHARACTERISTICS OF THE ADC .....	59
TABLE 25: BEHAVIOURS OF THE RI0.....	59
TABLE 26: WORKING STATE OF NETLIGHT .....	61
TABLE 27: PRODUCT SPECIFICATIONS OF U.FL-R-SMT.....	63
TABLE 28: THE MODULE CONDUCTED RF OUTPUT POWER.....	64
TABLE 29: THE MODULE CONDUCTED RF RECEIVING SENSITIVITY .....	64
TABLE 30: THE MODULE OPERATING FREQUENCY .....	64
TABLE 31: PIN ASSIGNMENT.....	65
TABLE 32: ABSOLUTE MAXIMUM RATINGS.....	66
TABLE 33: OPERATING TEMPERATURE .....	66
TABLE 34: THE MODULE POWER SUPPLY RATINGS.....	66
TABLE 35: THE MODULE CURRENT CONSUMPTION.....	68
TABLE 36: THE ESD ENDURANCE (TEMPERATURE: 25°C, HUMIDITY: 45 %). .....	70
TABLE 37: ORDERING INFORMATION .....	71
TABLE 38: ORDERING INFORMATION DF12 SERIES .....	74
TABLE 39: DIMENSIONS OF DF12 CONNECTOR.....	75
TABLE 40: DESCRIPTION OF DIFFERENT CODING SCHEME.....	79

TABLE 41: GPRS MULTI-SLOT CLASSES ..... 80

Quectel

## Figure Index

FIGURE 1: MODULE FUNCTIONAL DIAGRAM .....	17
FIGURE 2: REFERENCE BYPASS CAPACITORS FOR THE VBAT INPUT.....	24
FIGURE 3: REFERENCE CIRCUIT OF THE SOURCE POWER SUPPLY INPUT .....	24
FIGURE 4: RIPPLE IN SUPPLY VOLTAGE DURING TRANSMITTING BURST .....	25
FIGURE 5: TURN ON THE MODULE BY USING DRIVING CIRCUIT .....	27
FIGURE 6: TURN ON THE MODULE BY USING BUTTON.....	27
FIGURE 7: TIMING OF TURN ON THE MODULE .....	28
FIGURE 8: TIMING OF TURN OFF THE MODULE .....	30
FIGURE 9: REFERENCE CIRCUIT FOR EMERG_OFF BY USING DRIVING CIRCUIT .....	31
FIGURE 10: REFERENCE CIRCUIT FOR EMERG_OFF BY USING BUTTON.....	31
FIGURE 11: TIMING OF RESTART THE SYSTEM .....	32
FIGURE 12: TIMING OF RESTART THE SYSTEM AFTER EMERGENCY SHUTDOWN .....	32
FIGURE 13: CHARGING CIRCUIT CONNECTION.....	33
FIGURE 14: REFERENCE EXTERNAL BATTERY CHARGING CIRCUIT.....	34
FIGURE 15: NORMAL CHARGING PROCESS DIAGRAM .....	38
FIGURE 16: RTC SUPPLY FROM NON-CHARGEABLE BATTERY .....	42
FIGURE 17: RTC SUPPLY FROM RECHARGEABLE BATTERY .....	42
FIGURE 18: RTC SUPPLY FROM CAPACITOR .....	42
FIGURE 19: SEIKO XH414H-IV01E CHARGING CHARACTERISTIC .....	43
FIGURE 20: CONNECTION OF SERIAL INTERFACES .....	44
FIGURE 21: CONNECTION OF SOFTWARE UPGRADE .....	46
FIGURE 22: CONNECTION OF SOFTWARE DEBUGGING .....	47
FIGURE 23: RS-232 LEVEL CONVERTER CIRCUIT .....	47
FIGURE 24: ELECTRET MICROPHONE INTERFACE CONFIGURATION OF AIN1 .....	49
FIGURE 25: ELECTRET MICROPHONE INTERFACE CONFIGURATION OF AIN2.....	50
FIGURE 26: SIGNAL SOURCE INTERFACE CONFIGURATION OF AIN1/AIN2.....	50
FIGURE 27: SPEAKER INTERFACE CONFIGURATION OF AOUT1 .....	51
FIGURE 28: SPEAKER INTERFACE WITH AMPLIFIER IN AOUT1 .....	51
FIGURE 29: SPEAKER INTERFACE CONFIGURATION OF AOUT2 .....	52
FIGURE 30: SPEAKER INTERFACE WITH AMPLIFIER IN AOUT2 .....	52
FIGURE 31: EARPHONE INTERFACE CONFIGURATION.....	53
FIGURE 32: TIMING DIAGRAM OF DAI INTERFACE.....	55
FIGURE 33: REFERENCE CIRCUIT OF USING 8-PIN SIM CARD SOCKET.....	56
FIGURE 34: REFERENCE CIRCUIT OF USING 6-PIN SIM CARD SOCKET.....	57
FIGURE 35: AMPHENOL C707 10M006 512 2 SIM CARD HOLDER.....	57
FIGURE 36: MOLEX 91228 SIM CARD HOLDER .....	58
FIGURE 37: RI0 BEHAVIOUR OF VOICE CALLING AS A RECEIVER .....	60
FIGURE 38: RI0 BEHAVIOUR OF DATA CALLING AS A RECEIVER .....	60
FIGURE 39: RI0 BEHAVIOUR OF DATA CALLING AS A CALLER .....	60
FIGURE 40: RI0 BEHAVIOUR OF URC OR SMS RECEIVED .....	61
FIGURE 41: REFERENCE CIRCUIT OF NETLIGHT .....	61

FIGURE 42: ANTENNA PAD AND RF CONNECTOR.....	62
FIGURE 43: M20 TOP AND SIDE DIMENSIONS (UNIT: MM) .....	72
FIGURE 44: M20 MODULE MATCHS WITH THE APPLICATION BOARD (UNIT: MM) .....	72
FIGURE 45: FOOTPRINT OF RECOMMENDATION (UNIT: MM) .....	73
FIGURE 46: DIMENSIONS OF THE DF12 HEADER (UNIT: MM) .....	74
FIGURE 47: FOOTPRINT OF RECOMMENDATION (UNIT: MM) .....	75
FIGURE 48: PHYSICAL PHOTOS OF THE DF12 CONNECTORS.....	75
FIGURE 49: PHYSICAL PHOTOS OF THE U.F.L-R-SMT CONNECTOR (UNIT: MM) .....	76
FIGURE 50: MECHANICALS OF U.F.L-LP CONNECTORS .....	77
FIGURE 51: SPACE FACTOR OF MATED CONNECTOR (UNIT: MM) .....	77
FIGURE 52: TOP VIEW OF THE MODULE .....	78
FIGURE 53: BOTTOM VIEW OF THE MODULE.....	78
FIGURE 54: RADIO BLOCK STRUCTURE OF CS-1, CS-2 AND CS-3 .....	79
FIGURE 55: RADIO BLOCK STRUCTURE OF CS-4.....	79



## 0 Revision history

Revision	Date	Author	Description of change
1.00	2009-09-8	Yong AN	Initial
1.01	2009-09-17	Yong AN	Add SIM_GND Pin name descriptions Modify Figure 33 and Figure 34 about SIM card circuit Add current consumption of 2 Rx and 3 Tx in data mode Modify ordering information content in Chapter 6

## 1 Introduction

This document defines and specifies the M20 module series. For product ordering information, please refer to **Chapter 6 *Product Information***. This document describes the hardware interface of Quectel's M20 module series that connects to the specific application and the air interface.

This document can help you quickly understand module interface specifications, electrical and mechanical details. With the help of this document, associated application notes and user guide, customer can use M20 module to design and set up mobile applications quickly.

### 1.1 Related documents

**Table 1: Related documents**

SN	Document name	Remark
[1]	M20_ATC	M20 AT command set
[2]	ITU-T Draft new recommendation V.25ter	Serial asynchronous automatic dialing and control
[3]	GSM 07.07	Digital cellular telecommunications (Phase 2+); AT command set for GSM Mobile Equipment (ME)
[4]	GSM 07.10	Support GSM 07.10 multiplexing protocol
[5]	GSM 07.05	Digital cellular telecommunications (Phase 2+); Use of Data Terminal Equipment – Data Circuit terminating Equipment (DTE – DCE) interface for Short Message Service (SMS) and Cell Broadcast Service (CBS)
[6]	GSM 11.14	Digital cellular telecommunications system (Phase 2+); Specification of the SIM Application Toolkit for the Subscriber Identity module – Mobile Equipment (SIM – ME) interface
[7]	GSM 11.11	Digital cellular telecommunications system (Phase 2+); Specification of the Subscriber Identity module – Mobile Equipment (SIM – ME) interface
[8]	GSM 03.38	Digital cellular telecommunications system (Phase 2+); Alphabets and language-specific information
[9]	GSM 11.10	Digital cellular telecommunications system (Phase 2) ; Mobile Station (MS) conformance specification; Part 1: Conformance specification
[10]	GSM_UART_AN	The document of UART port application notes
[11]	M20_EVB_UGD	The document of M20 EVB user guide application notes

## 1.2 Terms and abbreviations

**Table 2: Terms and abbreviations**

Abbreviation	Description
ADC	Analog-to-Digital Converter
AMR	Adaptive Multi-Rate
ARP	Antenna Reference Point
ASIC	Application Specific Integrated Circuit
BER	Bit Error Rate
B2B	Board-to-Board
BTS	Base Transceiver Station
CHAP	Challenge Handshake Authentication Protocol
CS	Coding Scheme
CSD	Circuit Switched Data
CTS	Clear to Send
DAC	Digital-to-Analog Converter
DAI	Digital Acoustic Interface
DRX	Discontinuous Reception
DSP	Digital Signal Processor
DTE	Data Terminal Equipment (typically computer, terminal, printer)
DTR	Data Terminal Ready
DTX	Discontinuous Transmission
EFR	Enhanced Full Rate
EGSM	Enhanced GSM
EMC	Electromagnetic Compatibility
ESD	Electrostatic Discharge
ETS	European Telecommunication Standard
FCC	Federal Communications Commission (U.S.)
FDMA	Frequency Division Multiple Access
FR	Full Rate
GMSK	Gaussian Minimum Shift Keying
GPRS	General Packet Radio Service
GSM	Global Standard for Mobile Communications
HR	Half Rate
I/O	Input/Output
IC	Integrated Circuit
IMEI	International Mobile Equipment Identity
Inorm	Normal Current
Imax	Maximum Load Current
kbps	Kilo Bits per Second
LED	Light Emitting Diode

Li-Ion	Lithium-Ion
MO	Mobile Originated
MS	Mobile Station (GSM engine), also Referred to as TE
MT	Mobile Terminated
PAP	Password Authentication Protocol
PBCCH	Packet Switched Broadcast Control Channel
PCB	Printed Circuit Board
PDU	Protocol Data Unit
PPP	Point-to-Point Protocol
RF	Radio Frequency
RMS	Root Mean Square (value)
RTC	Real Time Clock
RX	Receiving Direction
SIM	Subscriber Identification Module
SMS	Short Message Service
SGSN	Service GPRS Support Node
TDMA	Time Division Multiple Access
TE	Terminal Equipment, also referred to as DTE
TX	Transmitting Direction
UART	Universal Asynchronous Receiver & Transmitter
URC	Unsolicited Result Code
USSD	Unstructured Supplementary Service Data
VSWR	Voltage Standing Wave Ratio
Vmax	Maximum Voltage Value
Vnorm	Normal Voltage Value
Vmin	Minimum Voltage Value
VIHmax	Maximum Input High Level Voltage Value
VIHmin	Minimum Input High Level Voltage Value
VILmax	Maximum Input Low Level Voltage Value
VILmin	Minimum Input Low Level Voltage Value
VImax	Absolute Maximum Input Voltage Value
VImin	Absolute Minimum Input Voltage Value
VOHmax	Maximum Output High Level Voltage Value
VOHmin	Minimum Output High Level Voltage Value
VOLmax	Maximum Output Low Level Voltage Value
VOLmin	Minimum Output Low Level Voltage Value
<b><i>Phonebook abbreviations</i></b>	
FD	SIM Fix Dialing phonebook
LD	SIM Last Dialing phonebook (list of numbers most recently dialed)
MC	Mobile Equipment list of unanswered MT Calls (Missed Calls)
ON	SIM (or ME) Own Numbers (MSISDNs) list

Abbreviation	Description
RC	Mobile Equipment list of Received Calls
SM	SIM phonebook

### 1.3 Safety caution

The following safety precautions must be observed during all phases of the operation. Usage , service or repair of any cellular terminal or mobile incorporating M20 module. Manufactures of the cellular terminal should send words the following safety information to users and operating personnel and to incorporate these guidelines into all manuals supplied with the product. If not so, Quectel does not take on any liability for customer failure to comply with these precautions.



When in a hospital or other health care facility, observe the restrictions about the use of mobiles. Switch the cellular terminal or mobile off, medical equipment may be sensitive to not operate normally for RF energy interference.



Switch off the cellular terminal or mobile before boarding an aircraft. Make sure it being switched off. The operation of wireless appliances in an aircraft is forbidden to prevent interference with communication systems. Forget to think much of these instructions may lead to the flight safety or offend against local legal action, or both.



Do not operate the cellular terminal or mobile in the presence of flammable gases or fumes. Switch off the cellular terminal when you are near petrol stations, fuel depots, chemical plants or where blasting operations are in progress. Operation of any electrical equipment in potentially explosive atmospheres can constitute a safety hazard.



Your cellular terminal or mobile receives and transmits radio frequency energy while switched on. RF interference can occur if it is used close to TV sets, radios, computers or other electric equipment.



Road safety comes first! Do not use a hand-held cellular terminal or mobile when driving a vehicle, unless it is securely mounted in a holder for hands-free operation. Before making a call with a hand-held terminal or mobile, park the vehicle.



GSM cellular terminals or mobiles operate over radio frequency signals and cellular networks and cannot be guaranteed to connect in all conditions, for example no mobile fee or a invalid SIM card. While you are in this condition and need emergent help, Please Remember using emergency calls. In order to make or receive calls, the cellular terminal or mobile must be switched on and in a service area with adequate cellular signal strength.

Some networks do not allow for emergency call if certain network services or phone features are in use (e.g. lock functions, fixed dialing etc.). You may have to deactivate those features before you can make an emergency call.

Also, some networks require that a valid SIM card be properly inserted in the cellular terminal or mobile.

## 2 Product concept

The M20 is a Quad-band GSM/GPRS engine that works at frequencies GSM850, EGSM 900 MHz, DCS 1800 MHz and PCS 1900 MHz. The M20 features GPRS multi-slot class 12(default)/class 10/class8 and supports the GPRS coding schemes CS-1, CS-2, CS-3 and CS-4. For more detail about GPRS multi-slot classes and coding schemes, please refer to Appendix A and Appendix B.

With a tiny profile of 35mm x 32.5mm x 2.95mm, the module can meet almost all the requirements for M2M applications, including Tracking and Tracing, Smart Metering, Wireless POS, Security, Telematics, Remote Controlling, etc.

The M20 is a B2B connector type module, which can be embedded in customer applications through its 50-pin connector. It provides all hardware interfaces between the module and customer's board.

- Two serial ports can help to easily develop customer's application.
- Two audio channels include two microphone inputs and two speaker outputs. This can be easily configured by AT command.

The module is designed with power saving technique so that the current consumption is as low as 1.1mA in SLEEP mode when DRX is 5.

The M20 is integrated with the Internet protocols; extended Internet service AT commands are developed for customer to use the Internet services easily, which is very useful for those data transfer applications.

The module is fully RoHS compliant to EU regulation.

### 2.1 Key features

**Table 3: Module key features**

Feature	Implementation
Power supply	Single supply voltage 3.4V – 4.5V
Power saving	Typical power consumption in SLEEP mode to 1.1 mA@ DRX=5 0.7 mA@ DRX=9
Frequency band	<ul style="list-style-type: none"> <li>● Quad-band: GSM850, EGSM 900, DCS1800, PCS1900</li> <li>● The module can search these frequency bands automatically</li> <li>● The frequency bands can be set by AT command</li> <li>● Compliant to GSM Phase 2/2+</li> </ul>
Transmitting power	<ul style="list-style-type: none"> <li>● Class 4 (2W) at GSM 850 and EGSM 900</li> </ul>

	<ul style="list-style-type: none"> <li>● Class 1 (1W) at DCS 1800 and PCS 1900</li> </ul>
GPRS connectivity	<ul style="list-style-type: none"> <li>● GPRS multi-slot class 12 (default)</li> <li>● GPRS multi-slot class 10 (option)</li> <li>● GPRS multi-slot class 8 (option)</li> <li>● GPRS mobile station Class B</li> </ul>
Temperature range	<ul style="list-style-type: none"> <li>● Normal operation: -35°C ~ +80°C</li> <li>● Restricted operation: -45°C ~ -35°C and +80°C ~ +85°C ①</li> <li>● Storage temperature: -45°C ~ +90°C</li> </ul>
DATA GPRS	<ul style="list-style-type: none"> <li>● GPRS data downlink transfer: max. 85.6 kbps</li> <li>● GPRS data uplink transfer: max. 85.6 kbps</li> <li>● Coding scheme: CS-1, CS-2, CS-3 and CS-4</li> <li>● Support the protocols PAP (Password Authentication Protocol) usually used for PPP connections</li> <li>● Integrate the TCP/IP protocols</li> <li>● Support Packet Switched Broadcast Control Channel (PBCCH)</li> </ul>
CSD	<ul style="list-style-type: none"> <li>● CSD transmission rates: 2.4, 4.8, 9.6, 14.4 kbps, non-transparent</li> <li>● Support Unstructured Supplementary Services Data (USSD)</li> </ul>
SMS	<ul style="list-style-type: none"> <li>● MT, MO, CB, Text and PDU mode</li> <li>● SMS storage: SIM card</li> </ul>
FAX	Group 3 Class 1
SIM interface	Support SIM card: 1.8V, 3V
Antenna interface	Connect via 50Ω antenna connector or antenna pad
Audio feature	<p>Speech codec modes:</p> <ul style="list-style-type: none"> <li>● Half Rate (ETS 06.20)</li> <li>● Full Rate (ETS 06.10)</li> <li>● Enhanced Full Rate (ETS 06.50 / 06.60 / 06.80)</li> <li>● Adaptive Multi-Rate (AMR)</li> <li>● Echo Cancellation</li> <li>● Echo Suppression</li> <li>● Noise Reduction</li> </ul>
Serial Interface	<p>Serial Port 0:</p> <ul style="list-style-type: none"> <li>● Seven lines on Serial Port 0</li> <li>● Use for AT command, GPRS data and CSD data</li> <li>● Support multiplexing function</li> <li>● Support baud rate from 75 bps to 115200 bps</li> <li>● Support Autobauding from 4800 bps to 115200bps</li> </ul> <p>Serial Port 1:</p> <ul style="list-style-type: none"> <li>● Software debug function</li> <li>● Two data lines RXD1 and TXD1</li> </ul>
Phonebook management	Support phonebook types: SM, FD, LD, RC, ON, MC
SIM Application Toolkit	Support SAT class 3, GSM 11.14 Release 99
Real time clock	Implemented



Alarm function	Programmable via AT command
Physical characteristics	Size: 35±0.15 x 32.5±0.15 x 3.1±0.3mm (including connector) 35±0.15 x 32.5±0.15 x 2.95±0.2mm (excluding connector) Weight: 5.5g
Firmware upgrade	Firmware upgrade over Serial Port 0

① When the module works in this temperature range, the deviations from the GSM specification might occur. For example, the frequency error or the phase error could increase.

**Table 4: Coding schemes and maximum net data rates over air interface**

Coding scheme	1 Timeslot	2 Timeslots	4 Timeslots
CS-1:	9.05kbps	18.1kbps	36.2kbps
CS-2:	13.4kbps	26.8kbps	53.6kbps
CS-3:	15.6kbps	31.2kbps	62.4kbps
CS-4:	21.4kbps	42.8kbps	85.6kbps

## 2.2 Functional diagram

The following figure shows a block diagram of the M20 module and illustrates the major functional part:

- The GSM baseband engine
- Flash and SRAM
- The GSM radio frequency part
- The antenna interface
- The B2B interface
  - SIM card interface
  - Audio interface
  - UART interface
  - Power supply
  - DAI interface

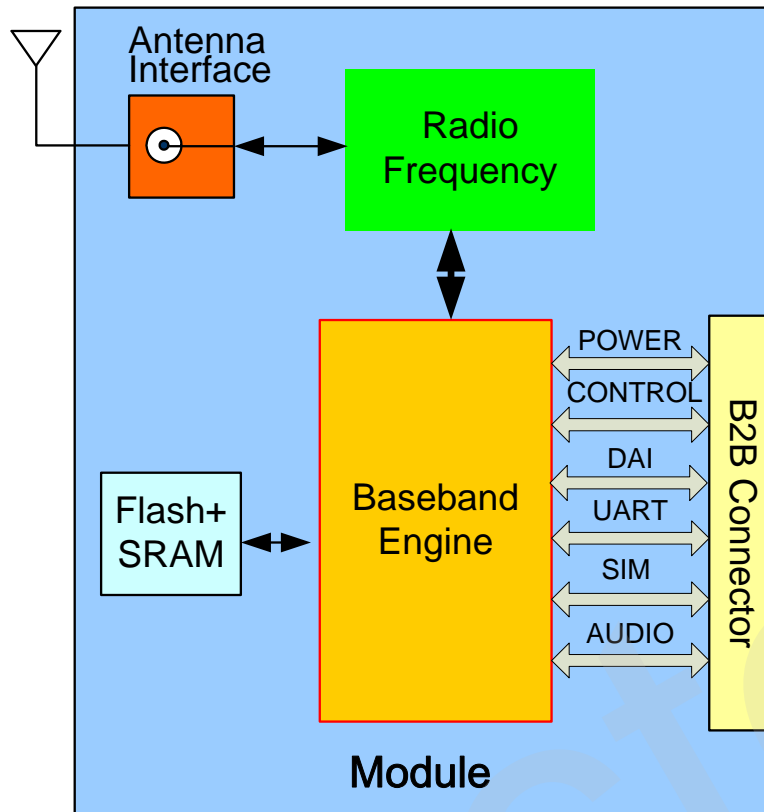


Figure 1: Module functional diagram

### 2.3 Evaluation board

In order to help customer on the application of M20, Quectel can supply an Evaluation Board (EVB) that hosts the module directly with appropriate power supply, SIM card holder, RS-232 serial interface, handset RJ11 port, earphone port, antenna and other peripherals to control or test the module. For details, please refer to the *M20\_EVB\_UGD* document.

### 3 Application interface

The module is equipped with a 50-pin 0.5mm pitch B2B connector that connects to the cellular application platform. Sub-interfaces included on this B2B connector are described in details in the following chapters:

- Power supply (*refer to Chapter 3.3*)
- Serial interface (*refer to Chapter 3.9*)
- Analog audio interface (*refer to Chapter 3.10*)
- SIM interface (*refer to Chapter 3.11*)

Electrical and mechanical characteristics of the B2B connector are specified in *Chapter 5 & Chapter 7*.

#### 3.1 Pin description

**Table 5: Pin description**

Power Supply				
PIN NAME	I/O	DESCRIPTION	DC CHARACTERISTICS	COMMENT
VBAT	I	VBAT pins of the B2B are dedicated to connect the supply voltage. The power supply of module has to be a single voltage source of VBAT= 3.4V...4.5V. It must be able to provide sufficient current in a transmitting burst which typically rises to 2A. Mostly, these 5 pins are voltage inputs.	Vmax= 4.5V Vmin=3.4V Vnorm=4.0V	
VCHG	I	Voltage input for the charging circuit	Vmax=6.5V Vmin=1.1 * VBAT Vnorm=5.0V	If unused, keep this pin open.
VRTC	I/O	Power supply for RTC when VBAT is not supplied for the system. Charging backup battery or golden capacitor when the VBAT is supplied.	VImax=VBAT VImin=2.6V VINorm=2.75V VOMax=2.85V VOMin=2.6V VOnorm=2.75V Iout(max)= 730uA Iin=2.6~5 uA	Recommend to connect to a backup battery or a golden capacitor.

VDD_EXT	O	Supply 2.8V voltage for external circuit. By measuring this pin, customer can judge whether the system is power on or off. When the voltage is low, the system is power off. Otherwise, the system is power on.	Vmax=2.9V Vmin=2.7V Vnorm=2.8V Imax=20mA	1.If unused, keep this pin open. 2. Recommend to add a 2.2~4.7uF bypass capacitor, when using this pin for power supply.
GND		Digital ground		
<b>Power on or power off</b>				
PIN NAME	I/O	DESCRIPTION	DC CHARACTERISTICS	COMMENT
PWRKEY	I	Voltage input for power on/off key. PWRKEY should be pulled down to turn on or turn off the system. Customer should keep pressing this key for a moment when turn on or turn off the module.	VILmax=0.3*VBAT VIHmin=0.7*VBAT VImax=VBAT	Pull up to VBAT internally.
<b>Emergency shutdown</b>				
PIN NAME	I/O	DESCRIPTION	DC CHARACTERISTICS	COMMENT
EMERG_OF F	I	Voltage input for emergency shutdown under emergent situation. EMERG_OFF should be pulled down for at least 20ms to shutdown the system in emergency. The module can restart by PWRKEY operation.	VILmax=0.4V VIHmin=2.2V V <sub>open</sub> max=2.8V	Open drain/collector driver required in cellular device application. If unused, keep this pin open.
<b>Audio interfaces</b>				
PIN NAME	I/O	DESCRIPTION	DC CHARACTERISTICS	COMMENT
MIC1P MIC1N	I	Audio input channel 1. Positive and negative voice input.	Audio DC Characteristics refer to chapter 3.10	No internal microphone bias supply. If unused keep these pins open.

MIC2P MIC2N	I	Audio input channel 2. Positive and negative voice input.		Microphone bias voltage supplied internally. If unused, keep these pins open.
SPK1P SPK1N	O	Audio output channel 1. Positive and negative voice output.		If unused keep these pins open.
SPK2P	O	Audio output channel 2. Auxiliary voice output.		If unused keep this pin open.
AGND		AGND is a separate ground connection for external audio circuit.		If unused keep this pin open.
<b>General purpose input/output</b>				
PIN NAME	I/O	DESCRIPTION	DC CHARACTERISTICS	COMMENT
NETLIGHT	O	Network status indication	VILmin=0V VILmax=0.67V VIHmin=1.7V VIHmax= VDD_EXT+0.3 VOLmin=GND VOLmax=0.34V VOHmin=2.0V VOHmax= VDD_EXT	If unused keep this open.
<b>DAI interface</b>				
PIN NAME	I/O	DESCRIPTION	DC CHARACTERISTICS	COMMENT
RXDDAI	I	Receive digital audio data	VILmin=0V	If unused keep these pins open.
TFSDAI	O	Frame synchronization	VILmax=0.67V	
SCLK	O	Serial bit clock	VIHmin=1.7V	
TXDDAI	O	Transmit digital audio data	VIHmax= VDD_EXT+0.3 VOLmin=GND VOLmax=0.34V VOHmin=2.0V VOHmax= VDD_EXT	
<b>Serial Port 0</b>				
PIN NAME	I/O	DESCRIPTION	DC CHARACTERISTICS	COMMENT
DTR0	I	Data terminal ready	VILmin=0V	If only use TXD0 and RXD0 to communicate, recommend to
RXD0	I	Receiving data	VILmax=0.67V	
TXD0	O	Transmitting data	VIHmin=1.7V	
RTS0	I	Request to send	VIHmax= VDD_EXT+0.3	
CTS0	O	Clear to send	VOLmin=GND	

RI0	O	Ring indicator	VOLmax=0.34V VOHmin=2.0V VOHmax= VDD_EXT	connect RTS0 pin to GND directly. If unused keep these pins open.
DCD0	O	Data carrier detection		
<b>Serial Port 1</b>				
RXD1	I	Receiving data		If unused keep these pins open.  These two pins are multiplex. RTS1, CTS1 function is not supported in default firmware and need to be customized if require. If unused keep these pins open.
TXD1	O	Transmitting data		
RTS1	I	Request to send of serial port1		
CTS1	O	Clear to send of serial port1		
<b>SIM interface</b>				
PIN NAME	I/O	DESCRIPTION	DC CHARACTERISTICS	COMMENT
SIM_VDD	O	Voltage supply for SIM card	The voltage can be selected by software automatically, 1.8V or 3V	All signals of SIM interface should be protected against ESD with a TVS diode array. Maximum trace length 200mm from the module pin to SIM card holder.
SIM_DATA	I/O	SIM data	VIHmin=0.7*SIM_VDD	
SIM_CLK	O	SIM clock	VOHmin=0.8*SIM_VDD	
SIM_RST	O	SIM reset	VOLmax=0.4V When SIM_VDD=3V VILmax=0.4V When SIM_VDD=1.8V VILmax=0.2* SIM_VDD VOHmin=0.9*SIM_VDD When SIM_VDD=3V VOLmax=0.4V When SIM_VDD=1.8V VOLmax=0.2* SIM_VDD	
SIM_PRESENCE	I	SIM card detection. Pulled down internally.	VILmax=0.67V VIHmin=1.7V	If SIM_PRESENCE goes

				from low to high, the module would execute a SIM card initialization process. If unused keep this pin open.
SIM_GND		Digital Ground of SIM Card		This pin is internally connected to GND and dedicated for SIM Card ground.
<b>AUXADC</b>				
PIN NAME	I/O	DESCRIPTION	DC CHARACTERISTICS	COMMENT
ADC1	I	ADC input	voltage range: 0V to 2.8V	If unused keep this pin open.

### 3.2 Operating modes

The table below briefly summarizes the various operating modes that the module supports.

**Table 6: Overview of operating modes**

Mode	Function	
Normal operation	GSM/GPRS SLEEP	The module will automatically enter SLEEP mode if DTR is set to high level when the slow clocking mode is enabled by setting “AT+QSCCLK=1” and there is no other task under execution. In this case, the current consumption of module will be reduced to very low level. During SLEEP mode, the module can still receive paging message for voice or SMS from GSM system.
	GSM IDLE	Software is active and the main controller is always running. The module has registered to GSM network thus it can receive paging message from network or send request to network.
	GSM TALK	GSM connection is going. In this case, the power consumption depends on network configurations such as Power Control Level (PCL) and working ARFCN channel.

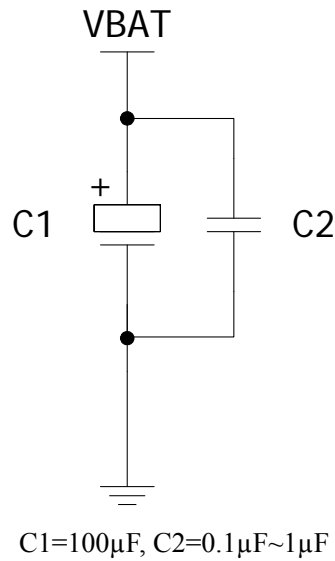
	GPRS IDLE	The module has not registered to GPRS network. The module is not reachable through GPRS channel.
	GPRS STANDBY	The module has registered to GPRS network, but PDP context is inactive. The SGSN knows the Routing Area where the module is located in.
	GPRS READY	The PDP context is active, but no data transfer is going on. The module is ready to receive or send GPRS data. The SGSN knows the cell where the module is located in.
	GPRS DATA	There is GPRS data in transfer. In this case, power consumption is related with network settings (PCL, GPRS multi-slot configuration).
POWER DOWN	Normal shutdown by sending the “AT+QPOWD=1” command, or by using the pin PWRKEY or using the pin EMERG_OFF <sup>①</sup> . The power supply to the base band part of the module will be turned off, and only the power supply for the RTC is remained. The serial interfaces are not accessible.	
Minimum functionality mode	The “AT+CFUN=0” command can be used to set the module to the minimum functionality mode without removing the power supply. In this mode, both the RF part and SIM card are closed while the serial interface is still accessible. If the slow clocking mode is enabled by “AT+QSCLK=1”, the power consumption would be less than 0.9mA.	
Alarm mode	RTC alert function wakes up the module from POWER DOWN mode. The module doesn't attempt to register to GSM network and only part of AT commands can be available. The module would return to POWER DOWN mode if failing to issuing “AT+CFUN=1” within 90 seconds after wakeup.	

<sup>①</sup>Use the pin EMERG\_OFF only when it fails to turn off the module by the “AT+QPOWD=1” and the pin PWRKEY. Please refer to Chapter 3.4.2.4.

### 3.3 Power supply

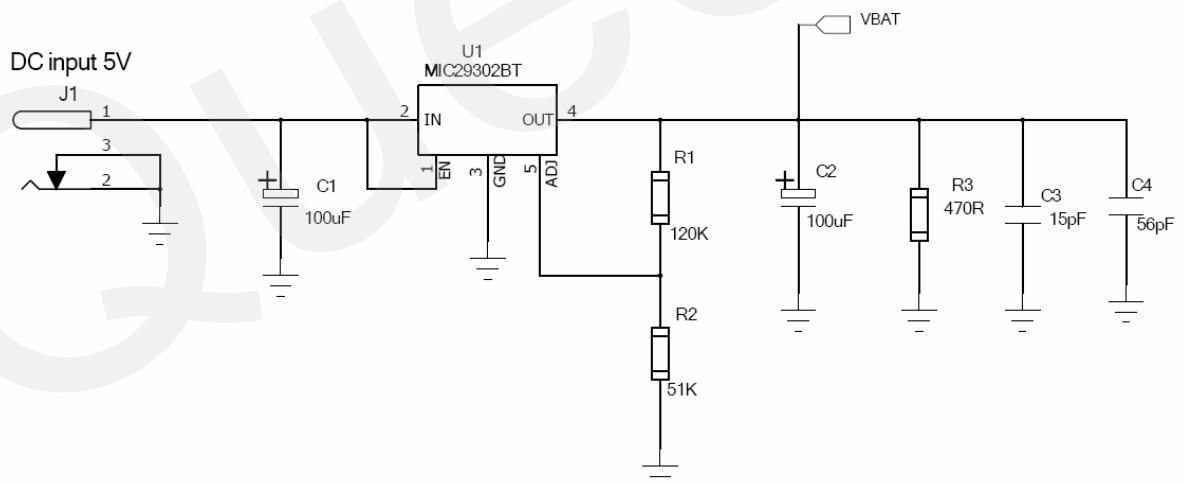
The power supply of the module is from a single voltage source of VBAT= 3.4V..4.5V. The GSM transmitting burst can cause obvious voltage drop at the supply voltage thus the power supply must be carefully designed and is capable of providing sufficient current up to 2A. For the VBAT input, a bypass capacitor of about 100  $\mu$ F with low ESR is recommended. Multi-layer ceramic chip (MLCC) capacitor can provide the best combination of low ESR and small size but may not be economical. A lower cost choice could be a 100  $\mu$ F tantalum capacitor with low ESR. A small (0.1 $\mu$ F to 1 $\mu$ F) ceramic capacitor should be in parallel with the 100 $\mu$ F capacitor, which is illustrated in Figure 2. The capacitors should be placed as close as possible to the M20 VBAT pins.





**Figure 2: Reference bypass capacitors for the VBAT input**

The circuit design of the power supply for the module largely depends on the power source. Figure 3 shows a reference design of +5V input power source. The designed output for the power supply is 4.16V, thus a linear regulator can be used. If there's a big voltage difference between the input source and the desired output (VBAT), a switching converter power supply would be preferable for its better efficiency especially with the 2A peak current in burst mode of the module.



**Figure 3: Reference circuit of the source power supply input**

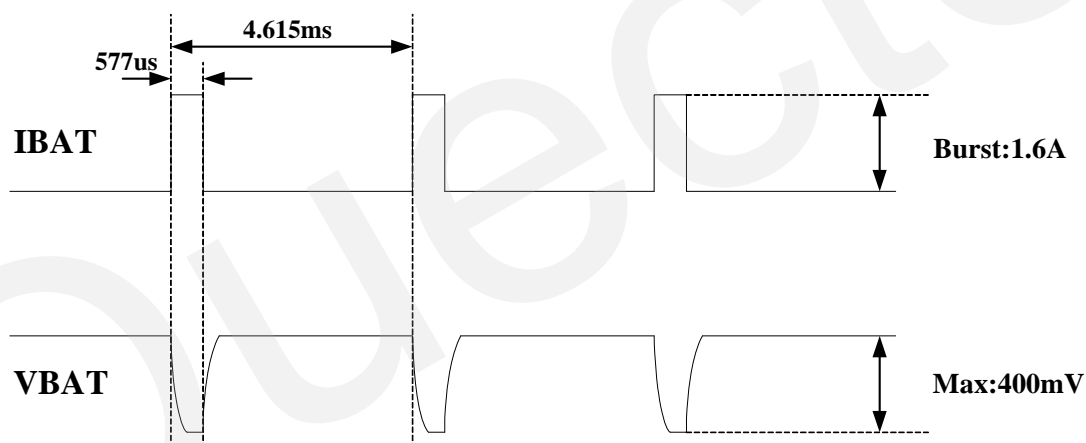
When the power supply for the module can't provide current of 2A, proper bigger capacitor is required so as to supply for the current demand during the burst transmission period. Reference capacitors for corresponding limited current supply are listed in Table 7.

**Table 7: Recommended bypass capacitors for limited current supply**

Maximum current output of power supply	Capacitance	ESR@ +25°C 100KHz (Ω)	Part number	Quantity of application	Vendor
1.5A	1500μF	≤0.045	592D158X06R3R2T20H	1	VISHAY
1A	2200μF	≤0.055	592D228X06R3X2T20H	2	VISHAY

The single 3.6V Li-Ion cell battery type can be connected to the power supply of the module VBAT directly. But the Ni\_Cd or Ni\_MH battery must be used carefully, since their maximum voltage could rise over the absolute maximum voltage for the module and damage it.

The RF Power Amplifier current (1.6A peak in GSM/GPRS mode) flows with a ratio of 1/8 of time, around 577us every 4.615ms, in talking mode. Figure 4 shows the VBAT voltage drop and current ripple at the maximum power transmitting phase, the test condition is VBAT=4.0V, VBAT voltage source maximum output current =2A, C1=100μF tantalum capacitor (ESR=0.7Ω) and C2=1μF.


**Figure 4: Ripple in supply voltage during transmitting burst**

### 3.3.1 Power supply pins

The VBAT pins are dedicated to connect the supply voltage; and the GND pins are recommended for grounding. VRTC pin can be used to connect a rechargeable coin battery or a golden capacitor which can help to maintain the system clock when VBAT supply is not applied.

### 3.3.2 Minimizing power losses

Please pay special attention to the power supply design for your applications. Please make sure that the input voltage will never drop below 3.4V even in a transmitting burst during which the

current consumption may rise up to 1.6A. If the power voltage drops below 3.4V, the module may be switched off. The PCB traces from the VBAT pads to the power source must be wide enough to ensure that there isn't too much voltage drop occur in the transmitting burst mode.

### 3.3.3 Monitoring power supply

To monitor the supply voltage, you can use the "AT+CBC" command which include three parameters: charging status, voltage percent and voltage value (in mV). It returns the battery voltage 1-100 percent of capacity and actual value measured between VBAT and GND. The voltage is continuously measured at interval depending on the operating mode. The displayed voltage (in mV) is averaged over the last measuring period before the "AT+CBC" command is executed.

For details please refer to *document [1]*

## 3.4 Power up and power down scenarios

### 3.4.1 Turn on

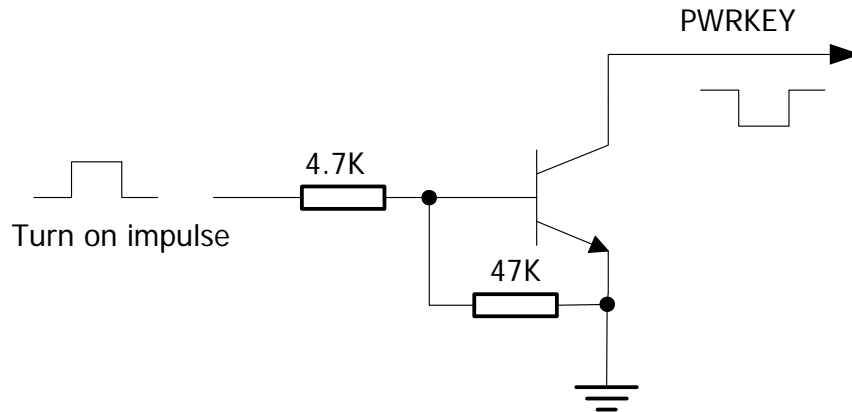
The module can be turned on by various ways, which are described in following chapters:

- Via PWRKEY pin: start normal operating mode (*please refer to chapter 3.4.1.1*)
- Via RTC interrupt: start ALARM mode (*please refer to chapter 3.4.1.2*)

*Note: AT command can be sent to the module after it is powered on and Unsolicited Result Code "RDY" is received from the serial port0. However if the module was set to autobauding mode, the URC "RDY" wouldn't be received from the serial port of the module. AT command can be sent to the module 2-3 seconds after the module is powered on. You can use "AT+IPR=x;&W" to set a fixed baud rate and save the configuration to non-volatile flash memory. After this configuration, the URC "RDY" should be received from the serial port0 every time when the module is powered on. Refer to Chapter "AT+IPR" in document [1].*

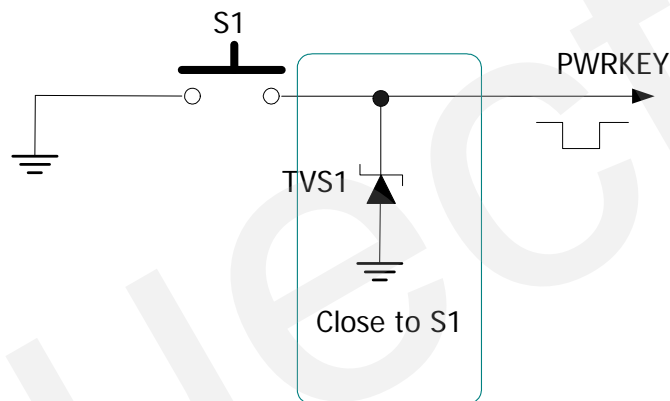
#### 3.4.1.1 Turn on module using the PWRKEY pin (Power on)

Customer's application can turn on the module by driving the pin PWRKEY to a low level voltage for some time and then releasing it. An open collector driver circuit is suggested to control the PWRKEY. A simple reference circuit is illustrated in Figure 5.



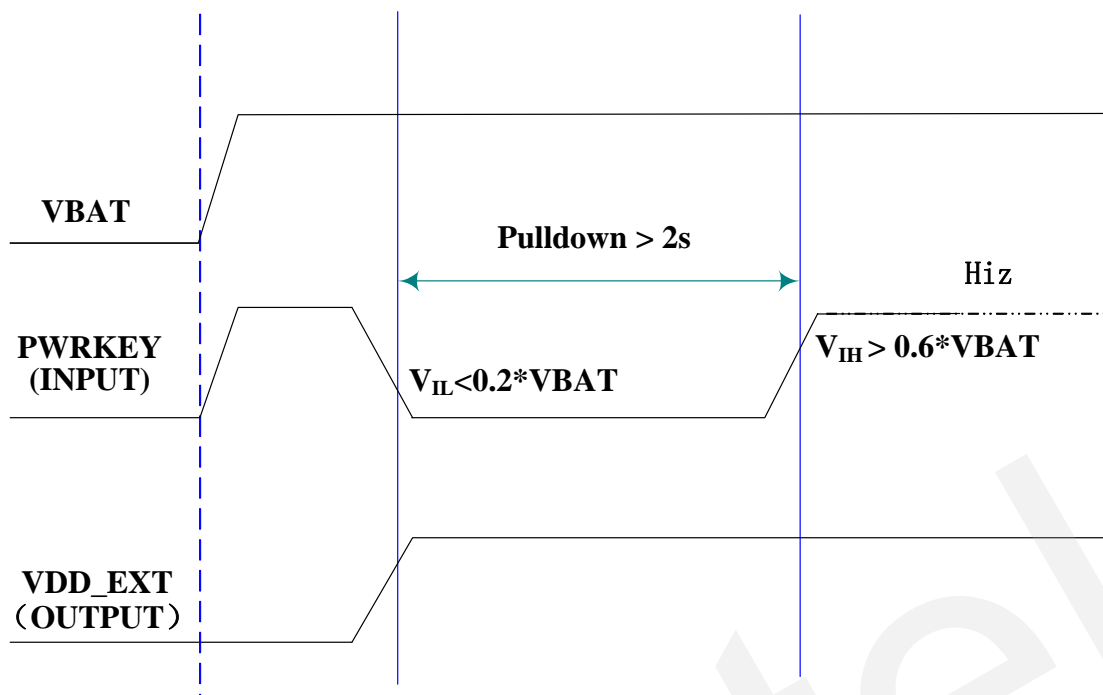
**Figure 5: Turn on the module by using driving circuit**

The other way to control the PWRKEY is using a button directly. A TVS component is indispensable to be placed nearby the button for ESD protection. When pressing the key, electrostatic strike may generate from finger. A reference circuit is showed in Figure 6.



**Figure 6: Turn on the module by using button**

The power-on scenario illustrates as in Figure 7.



**Figure 7: Timing of turn on the module**

When the power-on procedure completes, the module will send out the following result code to indicate the module is ready to operate when the baud rate of the serial port is set to fixed.

***RDY***

This result code does not appear when autobauding is active.

#### **3.4.1.2 Turn on module using the RTC (Alarm mode)**

Alarm mode is a power-on approach by using the RTC. The alert function of RTC can wake-up the module while it is in power-off state. In alarm mode, the module will not register to GSM network and the GSM protocol stack software is closed. Thus the part of AT commands related with SIM card and the protocol stack will not be accessible, and the others can be used.

Use the “AT+QALARM” command to set the alarm time. The RTC remains the alarm time if the module is powered off by “AT+QPOWD=1” or by PWRKEY pin. Once the alarm time is expired, the module will go into the alarm mode. In this case, the module will send out an Unsolicited Result Code (URC) when the baud rate of the serial port is set to fixed.

***ALARM RING***

***RDY***

This result code does not appear when autobauding is active.

During alarm mode, use “AT+CFUN” command to query the status of software protocol stack; it

will return 0 which indicates that the protocol stack is closed. After 90 seconds, the module will power down automatically. However, if the GSM protocol stack is started by “AT+CFUN=1” command during the alarm mode, the process of automatic power-off will not be executed. In alarm mode, driving the PWRKEY to a low level voltage for a period will cause the module to power down (Please refer to the power down chapter).

Table 8 briefly summarizes the AT commands that are frequently used during alarm mode, for detail of these instructions please refer to *document [1]*:

**Table 8: AT commands used in alarm mode**

AT command	Function
AT+QALARM	Set alarm time
AT+CCLK	Set data and time of RTC
AT+QPOWD	Power down the module
AT+CFUN	Start or close the protocol stack

### 3.4.2 Turn off

The following procedure can be used to turn off the module:

- Normal power down procedure: Turn off module using the PWRKEY pin
- Normal power down procedure: Turn off module using command “AT+QPOWD”
- Over-voltage or under-voltage automatic shutdown: Take effect when over-voltage or under-voltage is detected
- Emergent power down procedure: Turn off module using the EMERG\_OFF pin

#### 3.4.2.1 Turn off module using the PWRKEY pin (Power down)

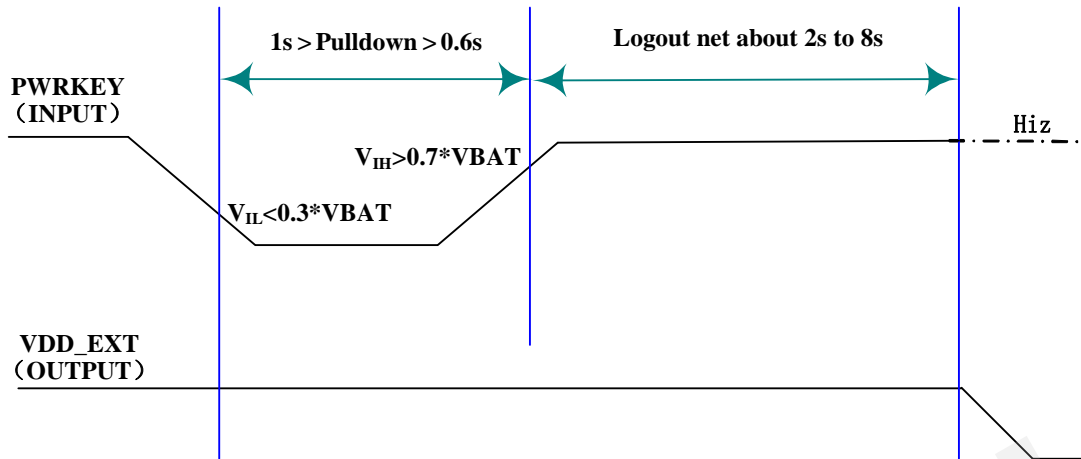
Customer’s application can turn off the module by driving the PWRKEY to a low level voltage for certain time. The power-down scenario illustrates as in Figure 8.

The power-down procedure causes the module logoff from the network and allow the software to save important data before completely disconnecting the power supply, thus it is a safe way.

Before the completion of the power-down procedure the module sends out the result code shown below:

***NORMAL POWER DOWN***

After this moment, no further AT command can be executed. And then the module enters the POWER DOWN mode, only the RTC is still active. The POWER DOWN mode can also be indicated by VDD\_EXT pin, which is a low level voltage in this mode.



**Figure 8: Timing of turn off the module**

### 3.4.2.2 Turn off module using AT command

Customer's application can use an AT command "AT+QPOWD=1" to turn off the module. This command will let the module to log off from the network and allow the software to save important data before completely disconnecting the power supply, thus it is a safe way.

Before the completion of the power-down procedure the module sends out the result code shown below:

***NORMAL POWER DOWN***

After this moment, no further AT command can be executed. And then the module enters the POWER DOWN mode, only the RTC is still active. The POWER DOWN mode can also be indicated by VDD\_EXT pin, which is a low level voltage in this mode.

Please refer to *document [1]* for detail about the AT command of "AT+QPOWD".

### 3.4.2.3 Over-voltage or under-voltage automatic shutdown

The module will constantly monitor the voltage applied on the VBAT, if the voltage  $\leq 3.5V$ , the following URC will be presented:

***UNDER-VOLTAGE WARNNING***

If the voltage  $\geq 4.5V$ , the following URC will be presented:

***OVER-VOLTAGE WARNNING***

The uncritical voltage range is 3.4V to 4.6V. If the voltage  $\geq 4.6V$  or  $\leq 3.4V$ , the module would automatically shutdown itself.

If the voltage  $\leq 3.4V$ , the following URC will be presented:

***UNDER-VOLTAGE POWER DOWN***

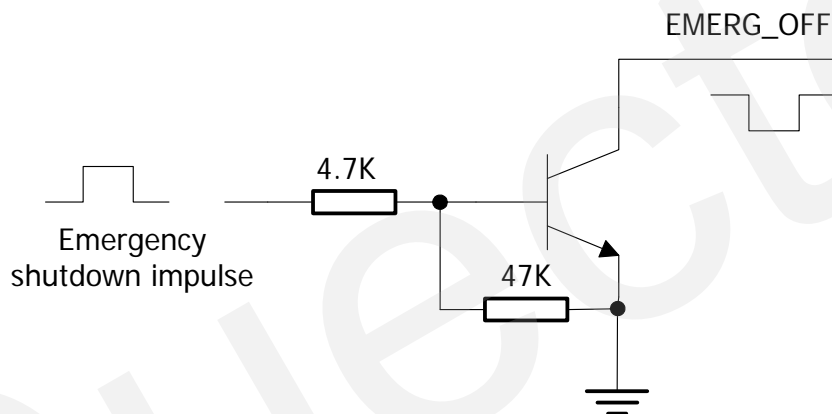
If the voltage  $\geq 4.6V$ , the following URC will be presented:

***OVER-VOLTAGE POWER DOWN***

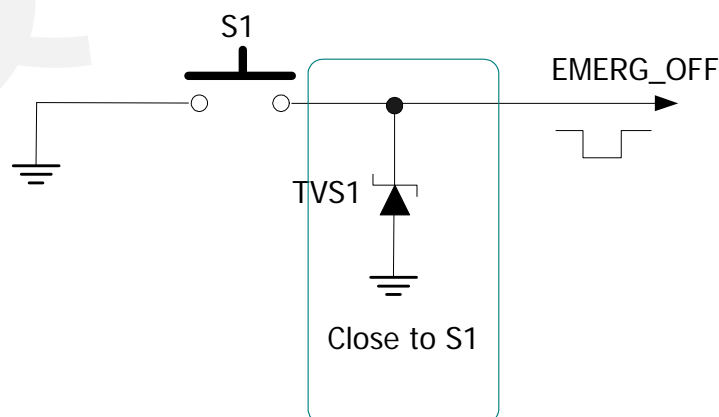
After this moment, no further AT command can be executed. The module logoff from network and enters POWER DOWN mode, and only RTC is still active. The POWER DOWN mode can also be indicated by the pin VDD\_EXT, which is a low level voltage in this mode.

#### 3.4.2.4 Emergency shutdown

The module can be shut down by driving the pin EMERG\_OFF to a low level voltage for over 20ms and then releasing it. The EMERG\_OFF line can be driven by an Open Drain/Collector driver or a button. The circuit illustrates as the following figures.



**Figure 9: Reference circuit for EMERG\_OFF by using driving circuit**



**Figure 10: Reference circuit for EMERG\_OFF by using button**

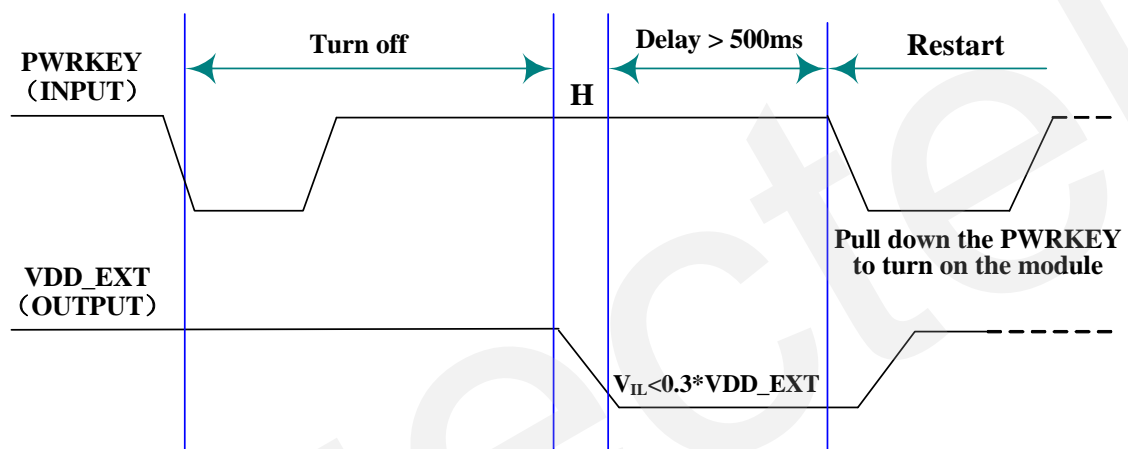
Be cautious to use the pin EMERG\_OFF. It should only be used under emergent situation. For instance, if the module is unresponsive or abnormal, the pin EMERG\_OFF could be used to



shutdown the system. Although turning off the module by EMERG\_OFF is fully tested and nothing wrong detected, this operation is still a big risk as it could cause destroying of the code or data area of the NOR flash memory in the module. Therefore, it is recommended that PWRKEY or AT command should always be the preferential way to turn off the system.

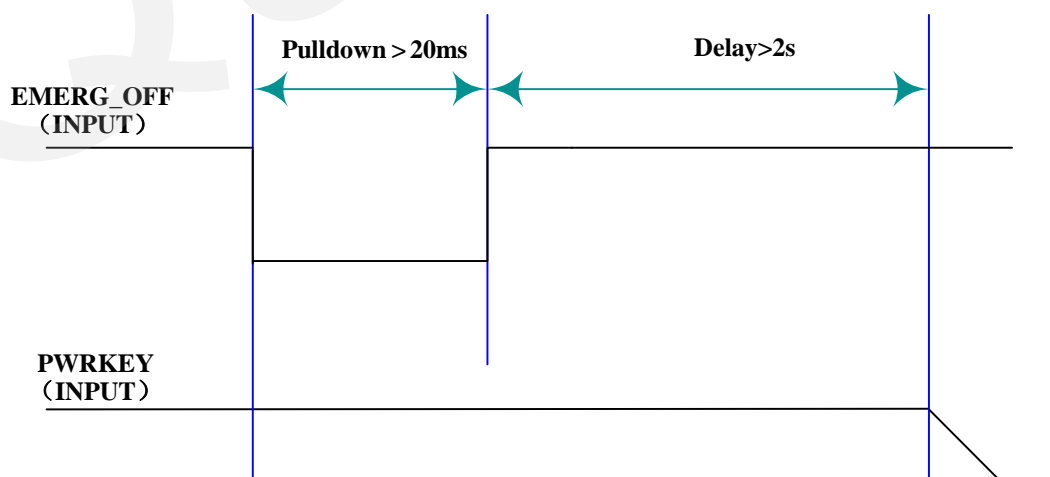
### 3.4.3 Restart module using the PWRKEY pin

Customer's application can restart the module by driving the PWRKEY to a low level voltage for certain time, which is similar to the way to turn on module. Before restarting the module, at least 500ms should be delayed after detecting the low level of VDD\_EXT. The restart scenario illustrates as the following figure.



**Figure 11: Timing of restart the system**

The module can also be restarted by the PWRKEY after emergency shutdown.

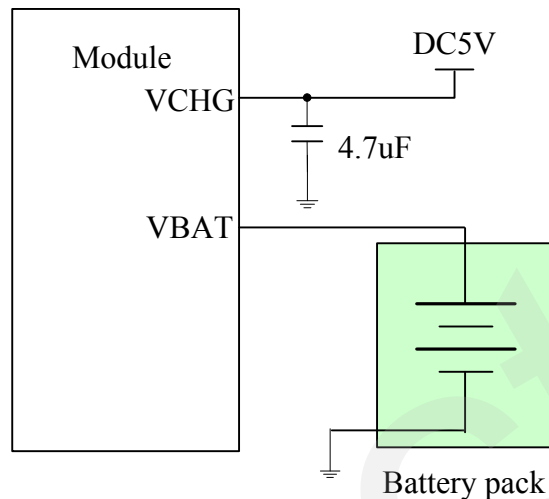


**Figure 12: Timing of restart the system after emergency shutdown**

### 3.5 Charging interface

The module has OPTIONALLY integrated a charging circuit for rechargeable Li-Ion or Lithium Polymer battery, which makes it very convenient for application to manage its battery charging.

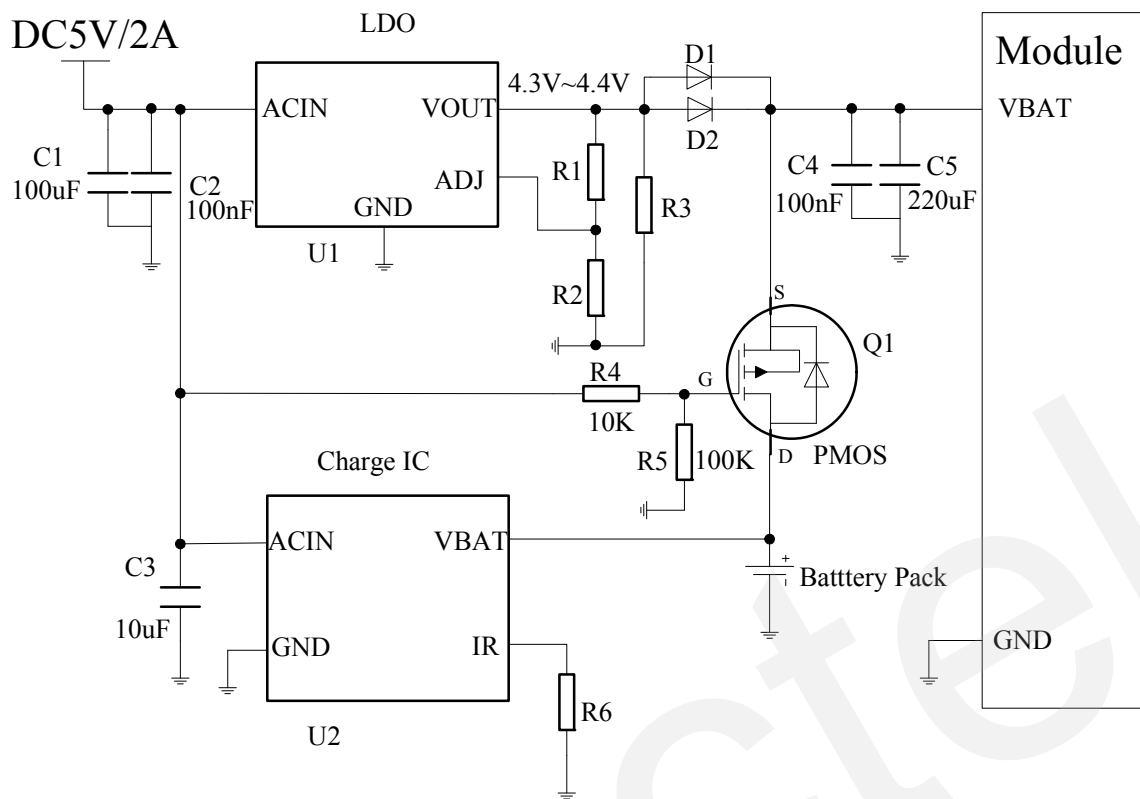
A common connection is shown in Figure 13.



**Figure 13: Charging circuit connection**

The charging function is not supported in standard M20 module. If customer needs this function, it would be necessary to contact Quectel. Furthermore, when battery charging is done by the charging function supported by the module, the VBAT would be mainly supplied by the battery and the external power source is used to charging the battery. In this case, when the battery is charged full, the charging circuit will stop working, but the charging function would be re-activated when the battery voltage drops to certain level. The battery is either in discharging mode or in charging mode, which could significantly shorten its life cycle. Therefore, it should always be cautious to use the internal charging function in M2M application.

A more suitable way to charging battery in M2M application is to use an external charging circuit which can charge the battery and put it into idle mode when battery is full. The VBAT is supplied by external power source instead of the battery, but when the external power source is cut off the battery will supply to the VBAT immediately. A reference block diagram for this design is shown in Figure 14.



**Figure 14: Reference external battery charging circuit**

Figure 14 shows the reference battery charging circuit for M2M application. U1 is an LDO which can supply current more than 2A and can output a voltage of 4.3~4.4V through adjusting the resistance of R1 and R2. R3 is the minimum load which value can usually be found in the datasheet of U1. Both D1 and D2 are Schottky barrier diodes, which is capable of forward current more than 1.5A and has low forward voltage drop and fast switching feature. Q1 is a P-channel MOSFET which acts as a switch between battery supply and external power supply. When the external power supply is present, Q1 is cut off and the module is powered by external supply. Otherwise, Q1 is turned on and the module is supplied by the battery. The Q1 P-channel MOSFET must be able to supply continuous drain current bigger than 2A. Moreover, on-resistance of Drain-to-Source should be as small as possible which means lower thermal power dissipation and voltage drop. U2 is a charging IC, which should be chosen according to the requirements of the application. Since the module is powered by external supply during most of the time in common application, charging current of more than 100mA would be enough. Furthermore, the external 5V DC power supply should be capable of supplying current more than the sum of maximum charging current and maximum module load current, which is happened in GPRS 4 slots transmission at highest power control level in GSM900MHz or GSM850MHz band.

### 3.5.1 Battery pack characteristics

The module has optimized the charging algorithm for the Li-Ion battery that meets the

characteristics listed below. To use the module's charging algorithm properly, it is recommended that the battery pack is compliant with these specifications, as it is important for the AT command "AT+CBC" to monitor the voltage of battery properly, or the "AT+CBC" may return incorrect battery capacity value.

- The maximum charging voltage of the Li-Ion battery pack is 4.2V and the capacity is greater than 500mAh.
- The battery pack should have a protection circuit to avoid overcharging, over-discharging and over-current. This circuit should be insensitive to pulsed current.
- On the GSM part of the module, the build-in power management chipset monitors the supply voltage constantly. Once the Under-voltage is detected, the module will power down automatically. Under-voltage thresholds are specific to the battery pack.
- The internal resistance of the battery and the protection circuit should be as low as possible. It is recommended that the battery internal resistance should not exceed 70mΩ and the internal resistance include battery and protection circuit of battery pack should not exceed 130mΩ.
- The battery pack must be protected from reverse pole connection.
- The Li-Ion/Polymer battery charging protection parameter is required as the following table

**Table 9: Recommended battery protect circuit parameter**

Item	Min.	Typ.	Max.
Over-charge protect threshold.(V)	4.25	4.3	4.35
Released Voltage from Over-charge(V)	4.1		4.2
Over-discharge protect threshold(V)	2.2		2.35
Released Voltage from Over-discharge(V)	2.35	2.4	2.45

### 3.5.2 Recommended battery pack

The following is the specification of the recommended battery pack:

**Table 10: Specification of the recommended battery pack**

Item	Remark
Product name & type	SCUD Li-Ion, 3.7V, 800mAh
To obtain more information, Please contact :	<b>SCUD (FU JIAN) Electronic CO., LTD.</b>
Normal voltage	3.7V
Capacity	Minimum 800mAh

Charging Voltage	4.200~4.23V
Max Charging Current	1.2C
Max Discharge Current	2C
Charging Method	CC / CV (Constant Current / Constant Voltage)
Internal resistance	≤130mΩ
Over-charge protect threshold.(V)	4.28 ± 0.025
Released Voltage from Over-charge(V)	4.08 ± 0.05
Over-discharge protect threshold(V)	2.3± 0.1
Released Voltage from Over-discharge(V)	2.4± 0.1

### 3.5.3 Implemented charging technique

There are two pins on the connector related with the internal battery charging function: VCHG and VBAT. The VCHG pin is driven by an external voltage, this pin can be used to detect an external charger supply and provide most charging current to external battery when it is in constant current charging stage. The module VBAT pin is connected directly to external battery positive terminal.

It is very simple to implement battery charging. Just connect the charger to the VCHG pin and connect the battery to the VBAT pin. When the module detects the charger supply and the battery are both present, battery charging happens. If there is no charger supply or no battery present, the charging function would not be enabled.

Normally, there are three main states in whole charging procedure.

- DDLO charging and UVLO charging
- CC (constant current) charging or fast charging
- CV (constant voltage) charging

Also for Li-ion battery , there is a additional Charge hold state.

#### **DDLO charging and UVLO charging:**

DDLO (deep discharge lock out) is the state of battery when its voltage is under 2.4V. And UVLO (under voltage lock out) is the state of battery when the battery voltage is less than 3.2V and more than 2.4V. The battery is not suitable for CC or CV charging when its condition is DDLO or UVLO. The module provides a small constant current to the battery when the battery is in DDLO or UVLO. The module provides current of about 15mA to the battery in the DDLO charging stage, and about 55mA to the battery in the UVLO charging stage.

DDLO charging terminates when the battery voltage reaches 2.4V. UVLO charging terminates when the battery voltage is up to 3.2V. Both DDLO and UVLO charging are controlled by the module hardware only.

**CC charging:**

When an external charger supply and battery have been inserted and the battery voltage is higher than 3.2V, the module enters CC charging stage. CC charging controlled by the software. In this charging stage, the module provides a constant current (about 550mA) through VBAT pins to the battery until battery voltage reaches to  $4.18 \pm 0.02V$ .

**CV charging:**

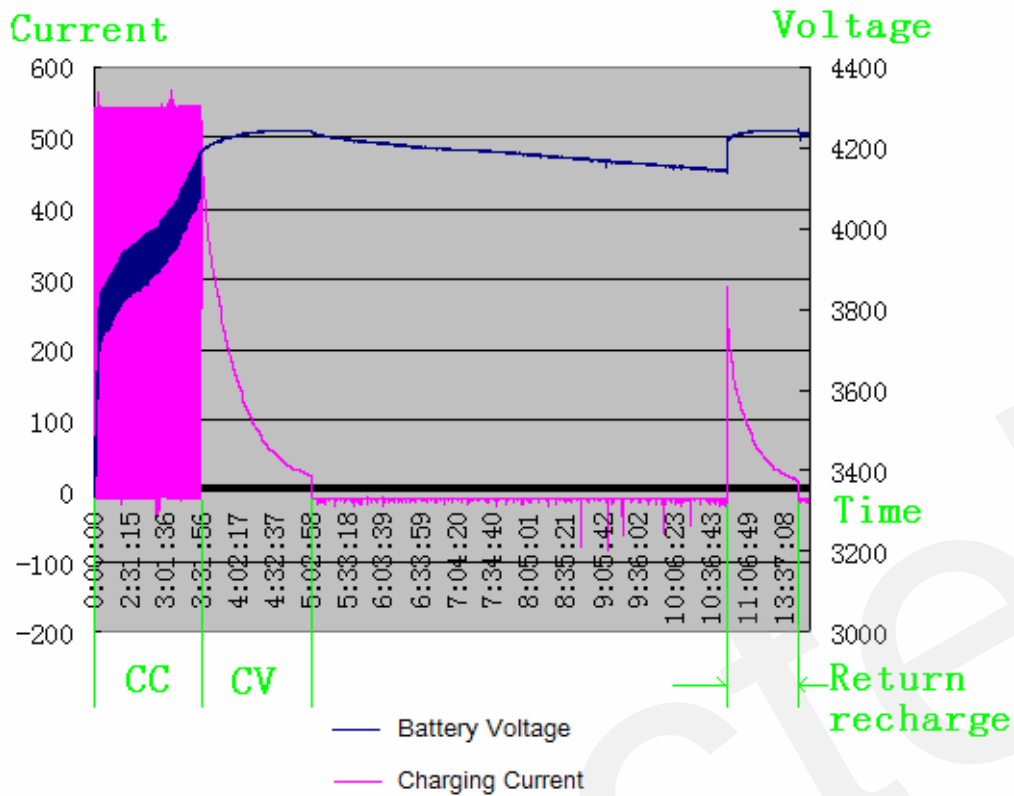
After CC charging ending, the module automatically enters constant voltage charging. When charging current steadily decreases to 50mA, the module begins to carry out 30 minutes charging delay. The CV charging will terminate after this delay.

**Charging hold (only for Li-Ion battery):**

The charging hold state is exclusively for Li-Ion battery. When the charger is applied, a voice call is connected and the battery voltage is above 4.05V, the module would enter Charge Hold state. The charging will pause until the battery voltage falls below 3.8V or the module goes into idle mode.

*Note: The module has a maximum charging time threshold, 6 hours. If the battery is not fully charged after 6 hours' constant charging, the module would terminate the charging operation immediately.*

The charging process is shown in Figure 15.



**Figure 15: Normal charging process diagram**

### 3.5.4 Operating modes during charging

The battery can be charged in various working modes such as SLEEP, TALK and GPRS DATA. It is named as Charging mode.

When a charger is connected to the module's VCHG pin, the battery is connected to the VBAT pin and the module is in POWER DOWN mode, the module enters the GHOST mode (Off and charging). The following table gives the differences between Charging mode and GHOST mode.

**Table 11: Operating modes**

	How to activate	Features
Charging Mode	Connect charger to module's VCHG pin, connect battery to VBAT pin of module while the module is in Normal operating mode, including: IDLE, TALK, GPRS STANDBY, GPRS READY and GPRS DATA mode, etc.	The module can normally operate.
GHOST Mode	Connect charger to module's VCHG pin while the module is in POWER DOWN mode.	Battery can be charged in GHOST mode. The module is not registered to GSM network. Only a few AT commands are available as listed in Table 12.

When the module is in the GHOST mode, AT commands listed in Table 12 can be used. For further instruction refer to document [1].

**Table 12: AT Commands available in the GHOST mode**

AT command	Function
AT+QALARM	Set alarm time
AT+CCLK	Set data and time of RTC
AT+QPOWD	Power down the module
AT+CBC	Indicated charging state and voltage
AT+CFUN	Start or close the protocol Setting AT command "AT+CFUN=1" to the module will transfer it from GHOST mode to Charging mode.

### 3.5.5 Charger requirements

The requirements of a suitable charger to match with the module internal charging function are listed below:

- Output voltage: 4.6V~6.5V, nominal voltage level is 5.0V.
- Charging current limitation: 650mA
- A 10V peak voltage is allowed for maximum 1ms when charging current is switched off.



- A 1.6A peak current is allowed for maximum 1ms when charging current is switched on.

### 3.6 Power saving

There are two methods to drive the module enter low current consumption status. “AT+CFUN” is used to set module into minimum functionality mode and DTR hardware interface signal can be used to lead system to enter SLEEP mode.

#### 3.6.1 Minimum functionality mode

Minimum functionality mode reduces the functionality of the module to minimum level, thus minimizes the current consumption when the slow clocking mode is activated at the same time. This mode is set with the “AT+CFUN” command which provides the choice of the functionality levels <fun>=0, 1, 4.

- 0: minimum functionality;
- 1: full functionality (default);
- 4: disable phone both transmitting and receive RF circuits;

If the module is set to minimum functionality by “AT+CFUN=0”, the RF function and SIM card function would be closed. In this case, the serial port is still accessible, but all AT commands correlative with RF function or SIM card function will not be accessible.

If the module has been set by “AT+CFUN=4”, the RF function will be closed, the serial port is still active. In this case, all AT commands correlative with RF function will not be accessible.

After the module is set by “AT+CFUN=0” or “AT+CFUN=4”, it can return to full functionality by “AT+CFUN=1”.

For detailed information about “AT+CFUN”, please refer to *document [1]*.

#### 3.6.2 SLEEP mode

The SLEEP mode is disabled in default software configuration. Customer’s application can enable this mode by “AT+QSCLK=1”. On the other hand, the default setting is “AT+QSCLK=0” and in this mode, the module can’t enter SLEEP mode.

When “AT+QSCLK=1” is set to the module, customer’s application can control the module to enter or exit from the SLEEP mode through pin DTR. When DTR is set to high level, and there is no on-air or hardware interrupt such as GPIO interrupt or data on serial port, the module will enter SLEEP mode automatically. In this mode, the module can still receive voice, SMS or GPRS paging from network but the serial port is not accessible.

### 3.6.3 Wake up module from the SLEEP mode

When the module is in the SLEEP mode, the following methods can wake up the module.

- DTR pin  
If the DTR Pin is pulled down to a low level, it would wake up the module from SLEEP mode. The serial port will be active after about 20ms when DTR be changed to low level.
- Receiving a voice or data call from network to wake up module.
- Receiving a SMS from network to wake up module.
- RTC alarm expired to wake up module.
- Keypad and PWRKEY interrupt

*Note: DTR pin should be held low level during communicating between the module and DTE.*

### 3.7 Summary of state transition (except SLEEP mode)

**Table 13: Summary of state transition**

Current mode	Further mode		
	POWER DOWN	Normal mode	Alarm mode
POWER DOWN		Use PWRKEY	Turn on the module by RTC alarm
Normal mode	AT+QPOWD, use PWRKEY pin, or use EMERG_OFF pin		Set alarm by “AT+QALARM”, and then turn off the module. When the timer expires, the module turns on automatically and enters Alarm mode.
Alarm mode	Use PWRKEY pin or wait module turning off automatically	Use AT+CFUN	

### 3.8 RTC backup

The RTC (Real Time Clock) can be supplied by an external capacitor or battery (rechargeable or non-chargeable) through the pin VRTC. A 3.9 K resistor has been integrated in the module for current limiting. A coin-cell battery or a super-cap can be used to backup power supply for RTC.

The following figures show various sample circuits for RTC backup.

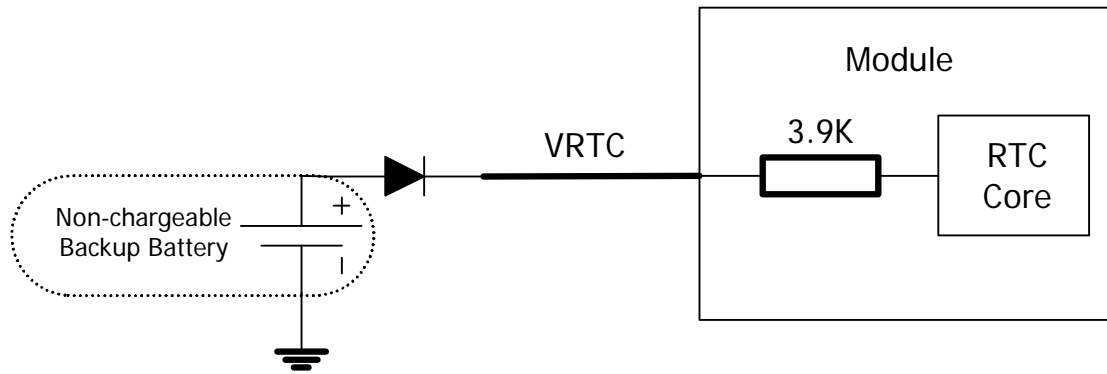


Figure 16: RTC supply from non-chargeable battery

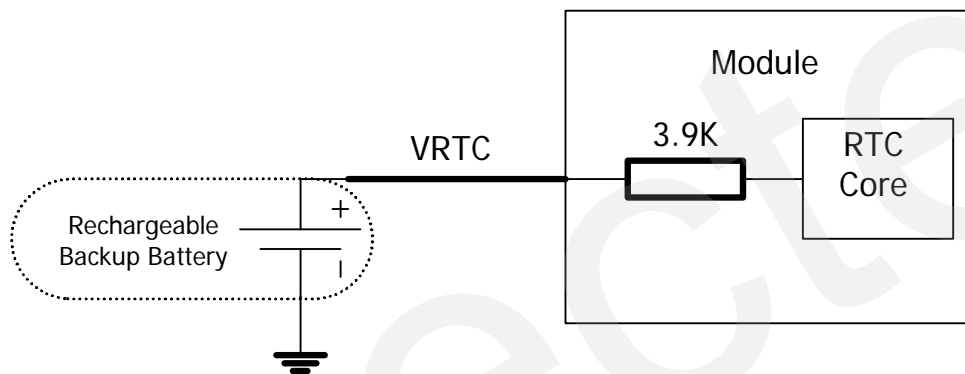


Figure 17: RTC supply from rechargeable battery

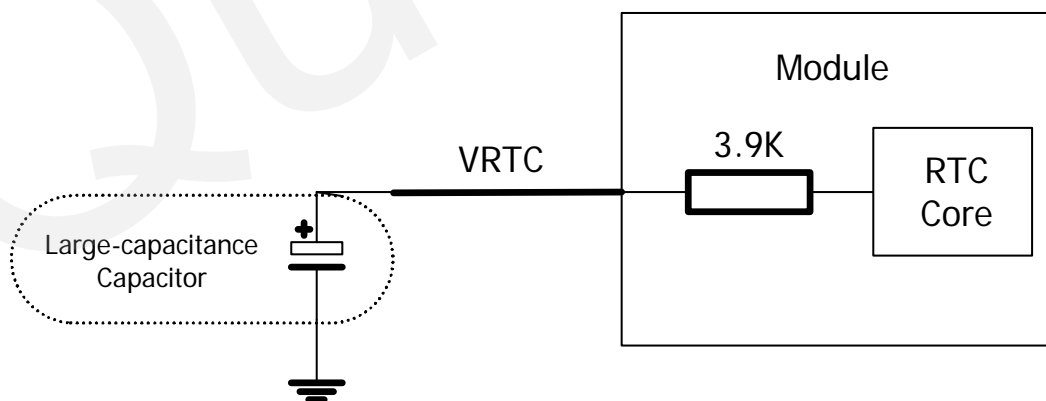
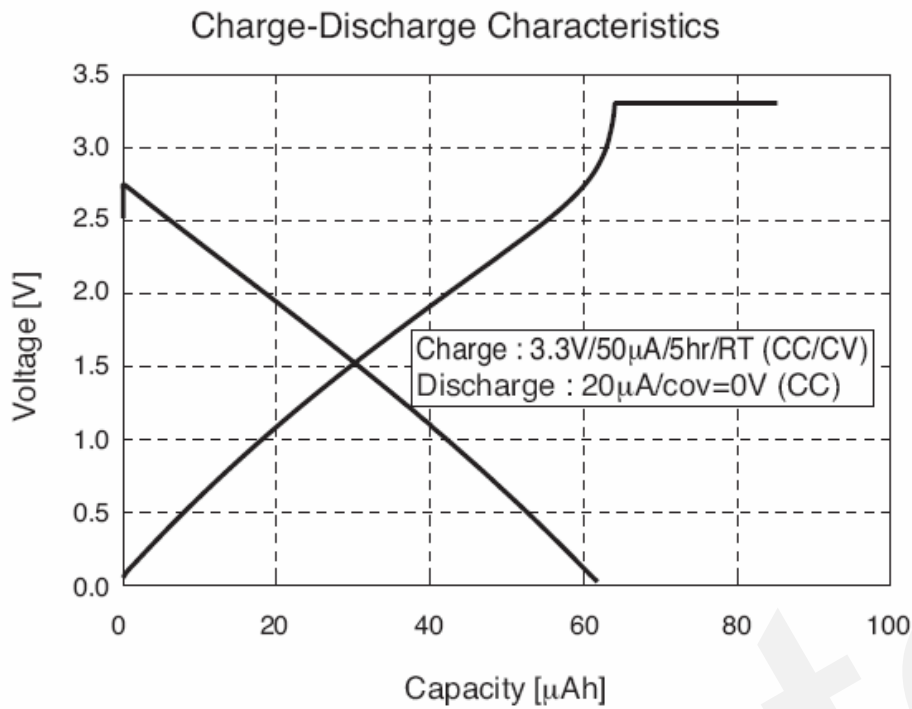


Figure 18: RTC supply from capacitor

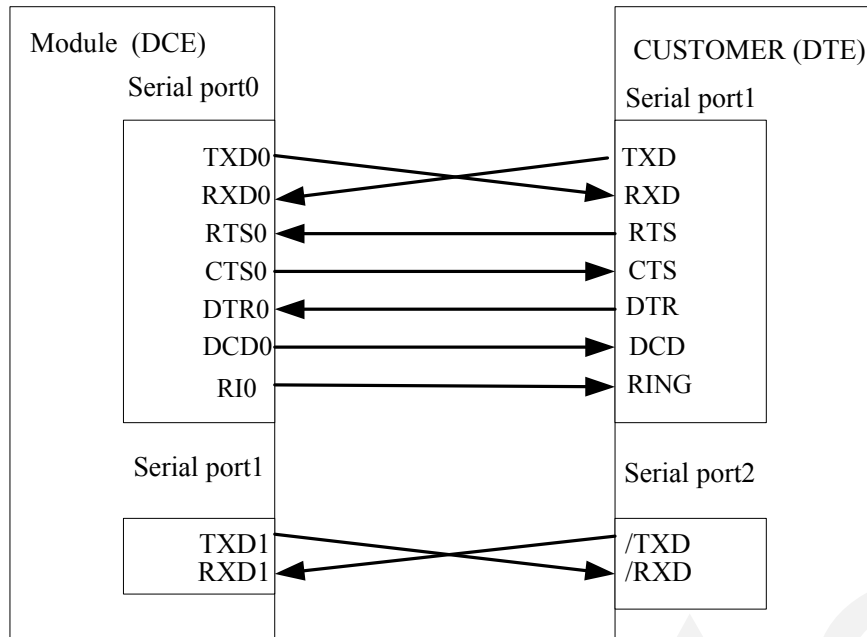
Coin-type rechargeable capacitor such as XH414H-IV01E form Seiko can be used.



**Figure 19: Seiko XH414H-IV01E charging characteristic**

### 3.9 Serial interface

The module provides two unbalanced asynchronous serial ports, serial port0 and serial port1. The module is designed as a DCE (Data Communication Equipment), following the traditional DCE-DTE (Data Terminal Equipment) connection. The module and DTE are connected through the following signal in Figure 20.



**Figure 20: Connection of serial interfaces**

#### Serial Port 0

- TXD0: Send data to the RXD signal line of DTE
- RXD0: Receive data from the TXD signal line of DTE

When hardware flow control is required, RTS0 and CTS0 should also be connected. The module supports hardware flow control in default. When the module is used as a modem, DCD0 and RI0 should be connected. Furthermore, RI0 could indicate the host controller when an event happens such as an incoming voice call, a URC data export.

#### Serial Port 1

- TXD1: Send data to the /RXD signal line of DTE
- RXD1: Receive data from the /TXD signal line of DTE

**Note:** Serial port 1 can also support hardware flow control together with RTS1 and CTS1. This port is only for software debugging and RTS1 and CTS1 flow control do not support in default firmware.

The logic levels are described in the following table.

**Table 14: Logic levels of serial port**

Parameter	Min	Max	Unit
V <sub>IL</sub>	0	0.67	V
V <sub>IH</sub>	1.67	VDD_EXT +0.3	V
V <sub>OL</sub>	GND	0.34	V
V <sub>OH</sub>	2.0	VDD_EXT	V

**Table 15: Pin definition of serial interface**

Interface	Name	Pin	Function
Serial port 0	RI0	32	Ring indicator
	RTS0	34	Request to send
	CTS0	37	Clear to send
	RXD0	17	Receive data of the serial port0
	TXD0	15	Transmitting data of the serial port0
	DTR0	35	Data terminal ready
	DCD0	39	Data carrier detection
Serial port 1	RXD1	16	Receive data of the serial port1
	TXD1	14	Transmitting data of the serial port1

### 3.9.1 Function of serial port 0 & serial port 1

#### Serial Port 0

- Seven lines on serial interface.
- Contain data lines TXD0 and RXD0, hardware flow control lines RTS0 and CTS0, other control lines DTR0, DCD0 and RI0.
- Use for AT command, GPRS data, CSD FAX, etc. Multiplexing function is supported at Serial Port 0. So far only the basic mode of multiplexing is available.
- Support the communication baud rates as the following:  
75,150,300,600,1200,2400,4800,9600,14400,19200,28800,38400,57600,115200  
Default setting is 115200bps.
- Support the following baud rates for Autobaoding function:  
4800, 9600, 19200, 38400, 57600, 115200bps

After setting a fixed baud rate or Autobaoding, please send “AT” string at that rate, the serial port is ready when it responds “OK”. Autobaoding is not compatible with multiplex mode.

Autobaoding allows the module to automatically detect the baud rate of the data sent from the host controller, which gives the flexibility to put the module into operation without considering which baud rate the host application is using. Autobaoding is disabled in default and can be activated by “AT+IPR”. To take advantage of the autobaoding mode, special attention should be paid to the following requirements:

### Synchronization between DTE and DCE:

When DCE (the module) powers on with the autobauding enabled, it is recommended to wait for 2 to 3 seconds before sending the first AT character. After receiving the “OK” response, DTE and DCE are correctly synchronized.

### Restrictions on autobauding operation

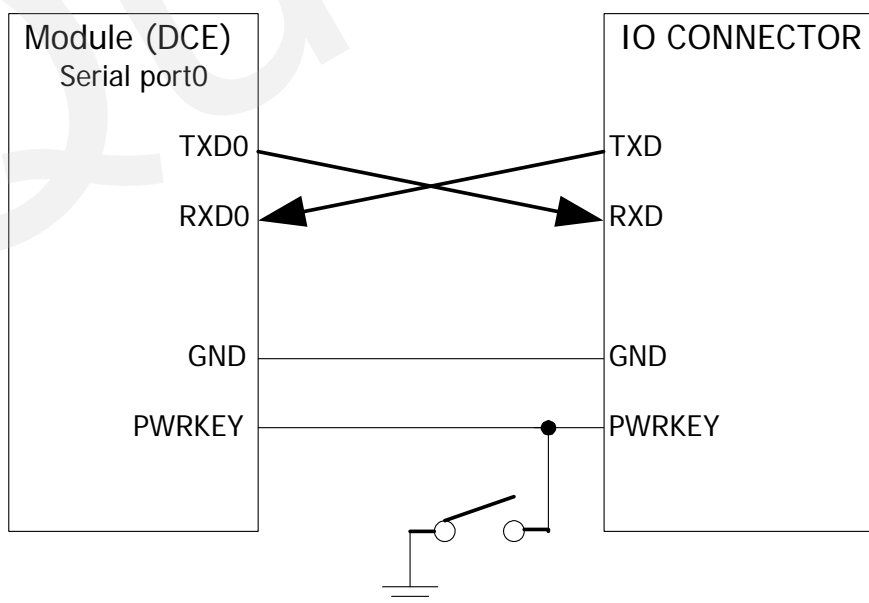
- The serial port has to be operated at 8 data bits, no parity and 1 stop bit (factory setting).
- The Unsolicited Result Codes like "RDY", "+CFUN: 1" and "+CPIN: READY" are not indicated when you start up the module while autobauding is enabled, because the baud rate used by the host controller can not be detected before inputting AT character .

### Serial Port 1

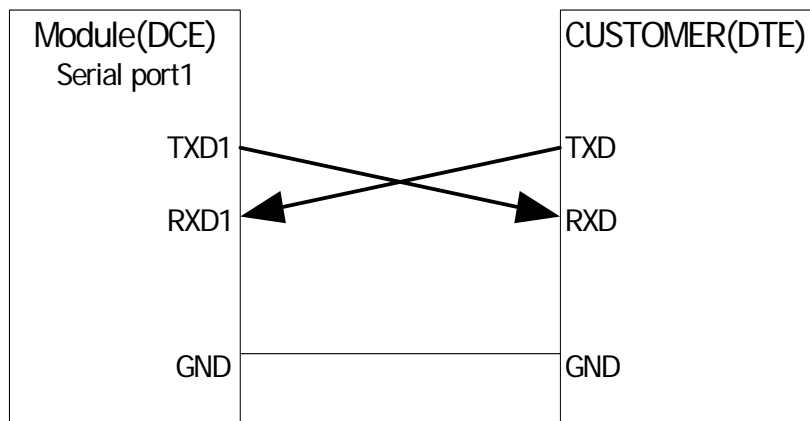
- Two data lines: TXD1 and RXD1
- Two hardware flow control lines: RTS1 and CTS1
- Serial port 1 is used for software debugging. It cannot be used for AT command, GPRS service, CSD call and FAX call. It doesn't support multiplexing and autobauding function.

### 3.9.2 Software upgrade and software debug

The TXD0、RXD0 can be used to upgrade software, while TXD1、RXD1 can be used for software debugging. Customer can insert a switch between the PWRKEY and the GND. The PWRKEY pin must be pulled down during the software upgrade process. Please refer to the following figures for software upgrade and debugging.

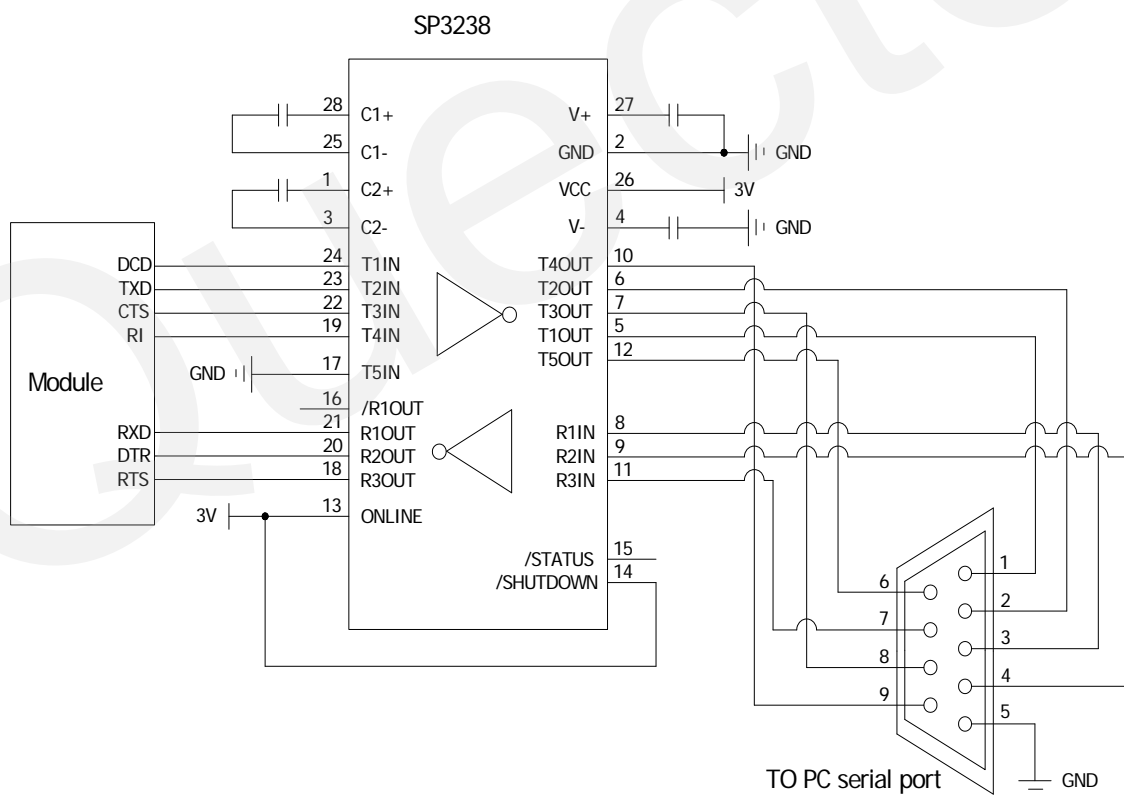


**Figure 21: Connection of software upgrade**



**Figure 22: Connection of software debugging**

The serial port 0 and the serial port 1 don't support the RS-232 level, but only support the CMOS level. A level shifter IC or circuit may be inserted between DCE and DTE. Figure 23 shows a reference level shifter circuit when the module is connected to a PC.



**Figure 23: RS-232 level converter circuit**

*Note : For detailed information about serial port application, please refer to document [10]*



### 3.10 Audio interfaces

The module provides two audio input channels and two audio output channels and one serial digital audio interface (DAI) on the B2B connector.

- AIN1 and AIN2, which may be used for both microphone and line inputs. An electret microphone is usually used. AIN1 and AIN2 are both differential input channels.
- AOUT1 and AOUT2, which may be used for both receiver and speaker outputs. AOUT1 channel is typically used with a receiver built into a handset, while AOUT2 channel is typically used with headset or hands-free speaker. AOUT1 channel is a differential channel and AOUT2 is a single-ended channel. SPK2P and AGND can establish a pseudo differential mode.
- These two audio channels can be swapped by “AT+QAUDCH” command. For more details, please refer to document [1].
- For each channel, customer can use AT+QMIC to adjust the input gain level of microphone. Customer can also use “AT+CLVL” to adjust the output gain level of receiver and speaker. “AT+QECHO” is to set the parameters for echo cancellation control. “AT+QSIDET” is to set the side-tone gain level. For more details, please refer to document [1].

*Note:*

- *Use AT command “AT+QAUDCH” to select audio channel:  
0--AIN1/AOUT1 (normal audio channel), the default value is 0.  
1--AIN2/AOUT2 (aux\_audio channel) .*

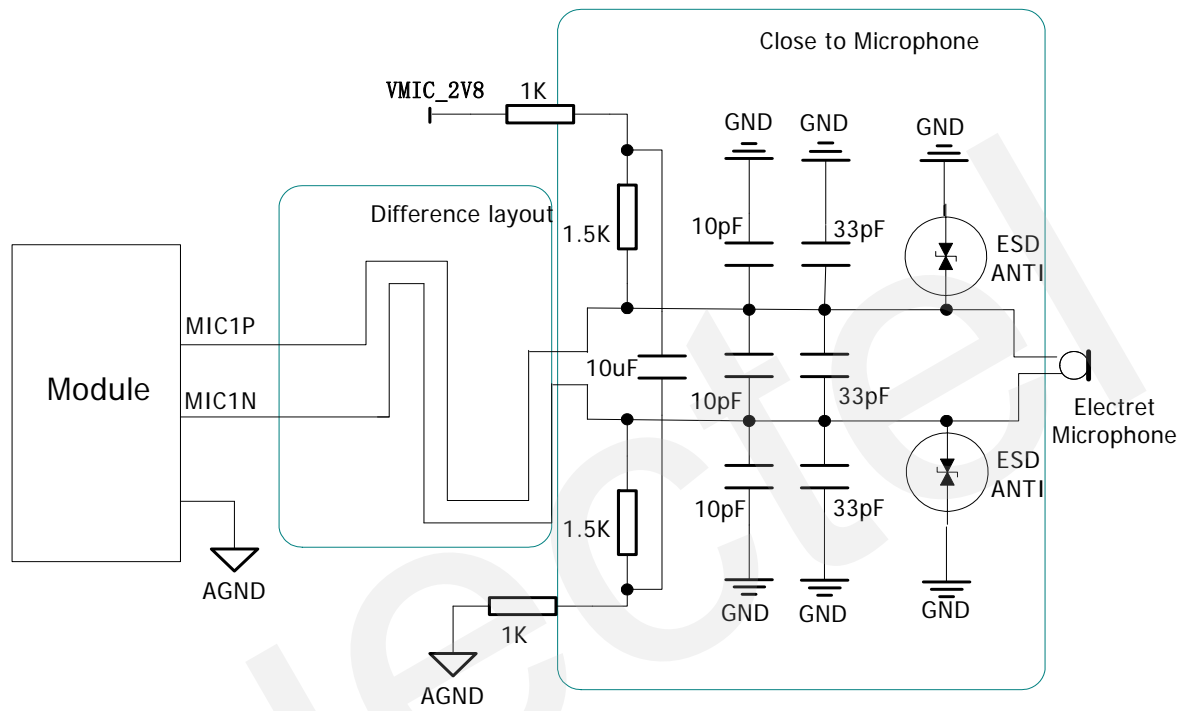
**Table 16: Pin definition of audio interface**

Interface	Name	Pin	Function
(AIN1/AOUT1)	MIC1P	44	Microphone1 input +
	MIC1N	43	Microphone1 input -
	SPK1P	48	Audio1 output+
	SPK1N	47	Audio1 output-
(AIN2/AOUT2)	MIC2P	45	Microphone2 input +
	MIC2N	46	Microphone2 input -
	SPK2P	49	Audio2 output+
	AGND	50	Suggest to be used as the analog ground in external audio circuit. Don't connect it to digital GND.

One of the following matching circuits can be chosen in order to improve audio performance. The differential audio traces have to be placed according to the differential signal layout rule. As shown in the following figures (*Note: the package of the 10p and 33p capacitors is 0603.*) Texas Instruments's TPA6205A1 is recommended for a suitable differential audio amplifier. There are plenty of excellent audio amplifiers in the market.

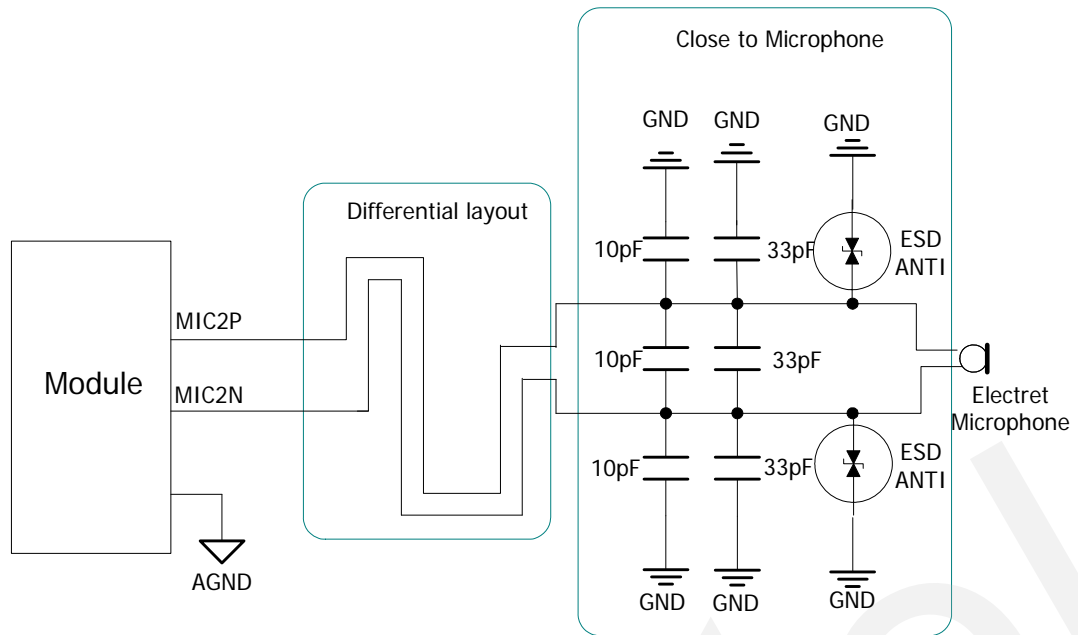
### 3.10.1 Microphone interface configuration

AIN1 channel has no internal bias supply for external microphone, thus an external bias circuit must be added when connecting electret microphone to AIN1 channel. A reference circuit is shown in Figure 24. The LDO to supply VMIC should use AGND of the module as its ground instead of GND of the module to suppress TDD noise.



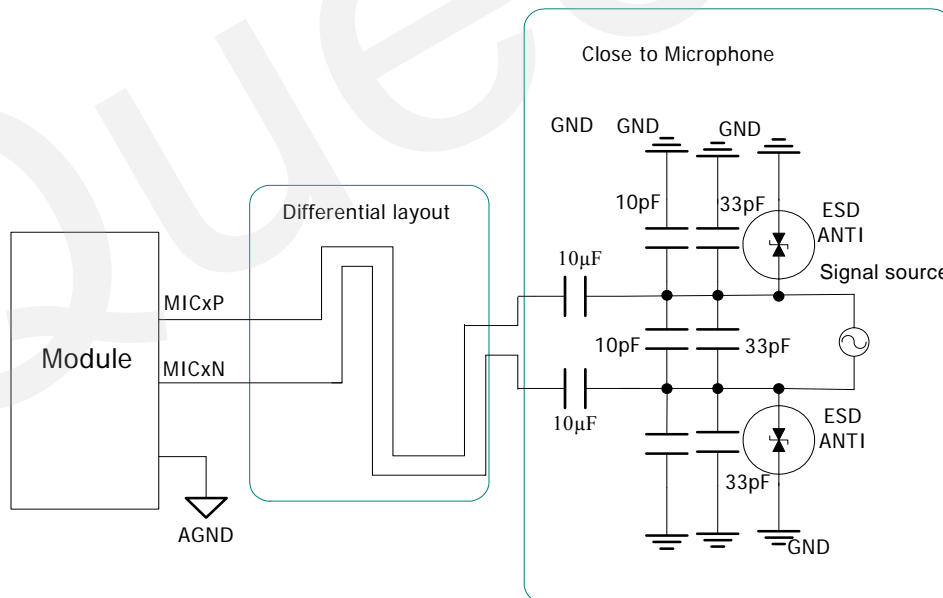
**Figure 24: Electret microphone interface configuration of AIN1**

AIN2 channel comes with an internal bias supply for external microphone. A reference circuit is shown in Figure 25.



**Figure 25: Electret microphone interface configuration of AIN2**

If AIN1/AIN2 channels are connected to other type of audio signal source instead of electret microphone, for example, an op amp or a moving-coil type microphone, it is recommended to insert two 10 $\mu$ F capacitors for decoupling.



**Figure 26: Signal source interface configuration of AIN1/AIN2**

3.10.2 Speaker interface configuration

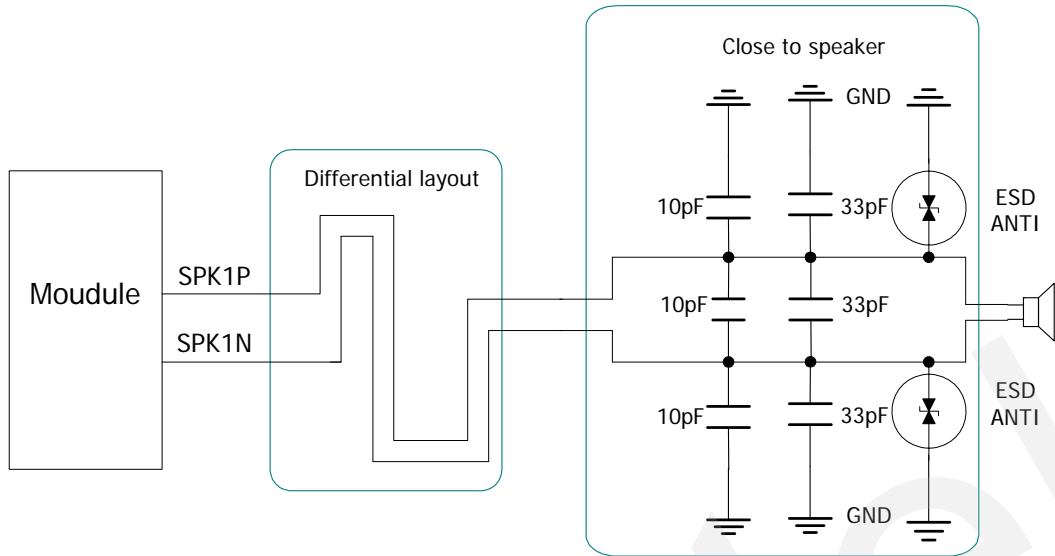


Figure 27: Speaker interface configuration of AOUT1

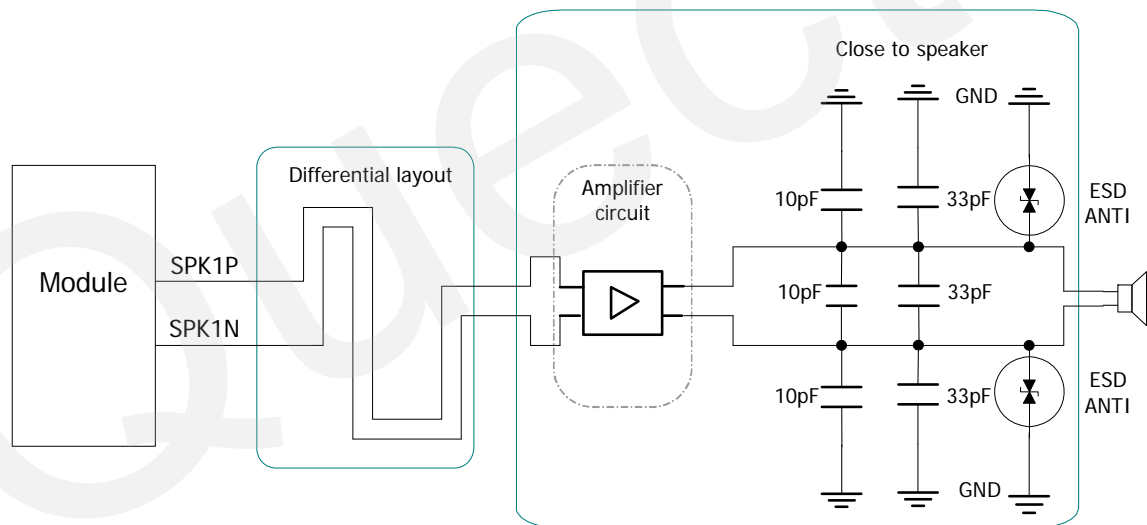
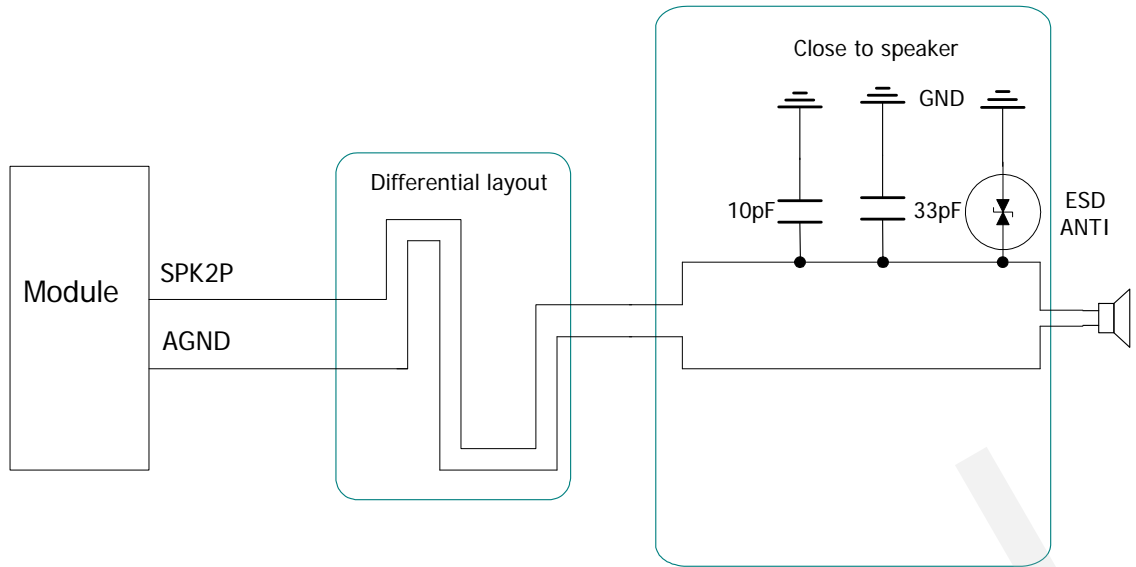
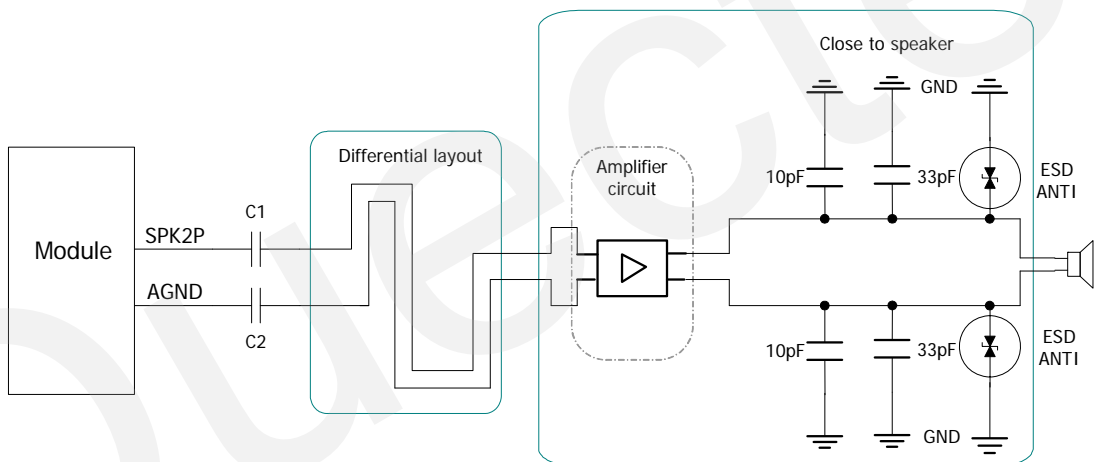


Figure 28: Speaker interface with amplifier in AOUT1



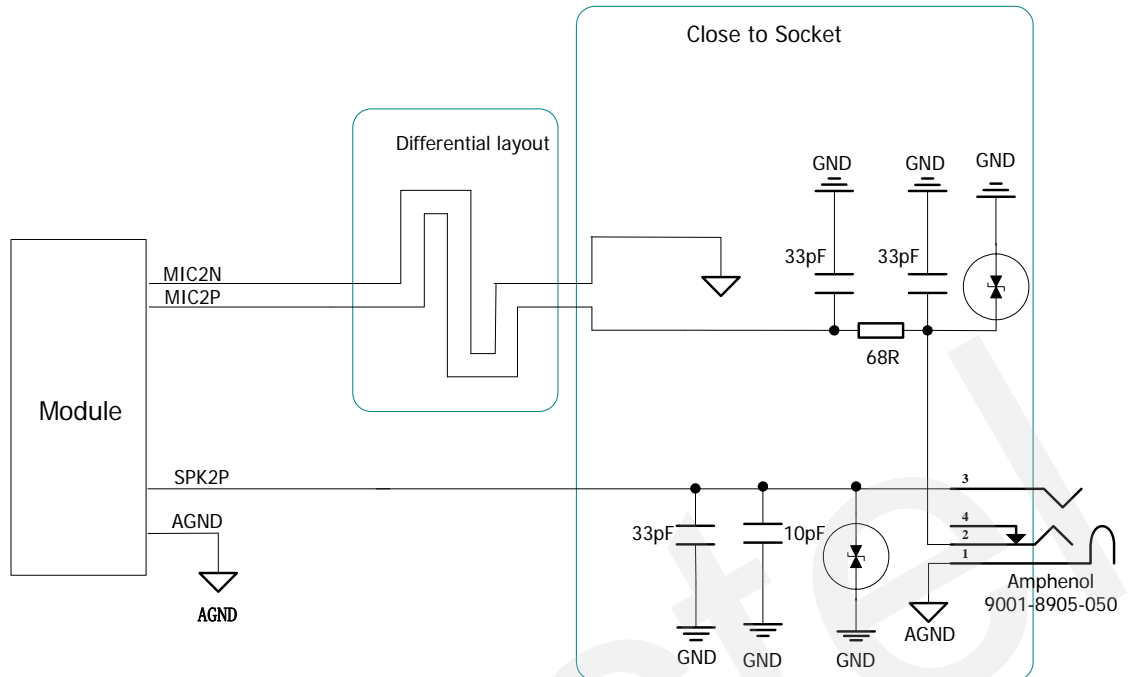
**Figure 29: Speaker interface configuration of AOUT2**



**Figure 30: Speaker interface with amplifier in AOUT2**

*Note: The value of C1 and C2 depends on the input impedance of audio amplifier.*

### 3.10.3 Earphone interface configuration



**Figure 31: Earphone interface configuration**

*Note: The module supports optionally earphone detection and hook off in hardware, In other words, it is not supported in default hardware configuration. If customer needs earphone detection or hook off detection, please contact Quectel.*

**Table 17: Typical electret microphone input characteristic**

Parameter	Min	Typ	Max	Unit
Working Voltage	1.2	1.5	2.0	V
Working Current	200		500	$\mu$ A
External Microphone Load Resistance		2.2		k $\Omega$

**Table 18: Typical speaker output characteristic**

Parameter			Min	Typ	Max	Unit
Normal Output(SPK1)	Single Ended	load Resistance	28	32		$\Omega$
		Ref level	0		2.4	Vpp
	Differential	load Resistance	28	32		$\Omega$
		Ref level	0		4.8	Vpp
Auxiliary Output(SPK2)	Single Ended	load Resistance	16	32		$\Omega$
		Ref level	0		2.4	Vpp
Maxim driving current limit of SPK1 and SPK2					50	mA

### 3.10.4 DAI interface (optional)

The module provides digital audio interface on the B2B connector. This interface can communicate with external digital audio interface, such as BT, CODEC and only supports master mode. Each pin definition of the DAI interface is listed in Table 19.

**Table 19: Pin definition of the DAI interface**

Interface	Name	Pin	Function
DAI	RXDDAI	7	Receive digital audio signal
	TFSDAI	8	Frame synchronization signal
	SCLK	9	Serial bit clock
	TXDDAI	10	Transmit digital audio signal

The SCLK clock signal is an output, generating a 256KHz bit clock as master. The TFSDAI frame sync signal is an output, generating an 8KHz, and both long frame sync and short frame sync are supported. The PCM interface can transmit 16-bit stereo or 32-bit mono 8 kHz sampling rate voice signal. Figure 32 shows the timing diagram of the DAI interface. Note that the serial data changes when the clock is rising and is latched when the clock is falling.

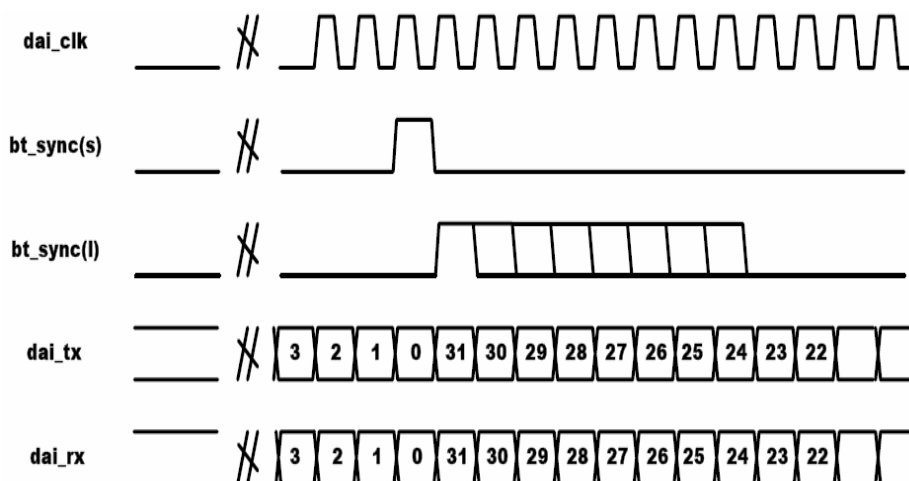


Figure 32: Timing diagram of DAI interface

*Note: This function is not supported in the default firmware. If need, please contact Quectel.*

### 3.11 SIM card interface

#### 3.11.1 SIM card application

Customer can get information in SIM card by AT Command. For more information, please refer to document [1].

The SIM interface supports the functionality of the GSM Phase 1 specification and also supports the functionality of the new GSM Phase 2+ specification for FAST 64 kbps SIM card, which is intended for use with a SIM application Tool-kit.

Both 1.8V and 3.0V SIM cards are supported. The SIM interface is powered from an internal regulator in the module.

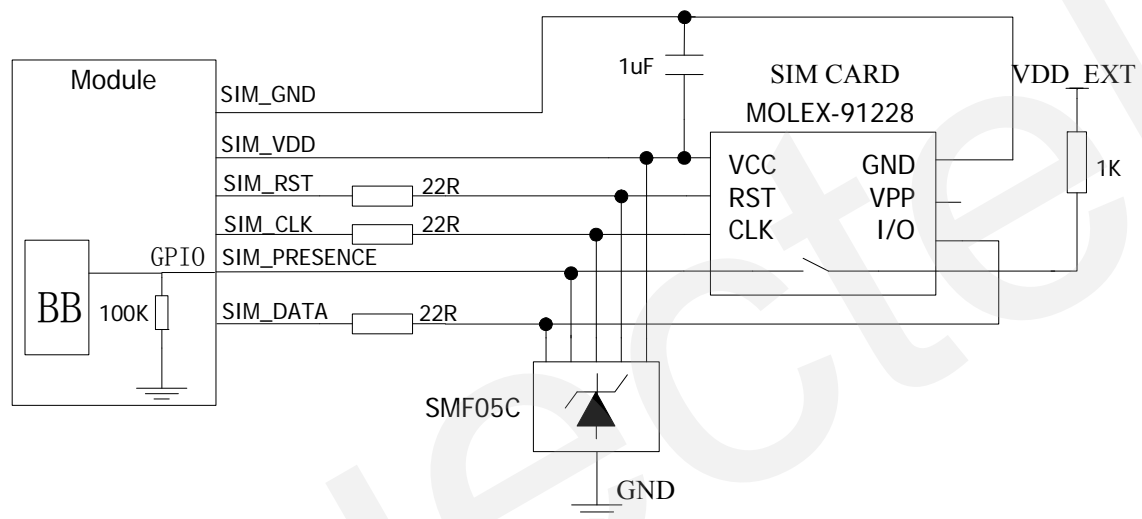
Table 20: Pin definition of the SIM interface

Name	Pin	Function
SIM_VDD	2	Supply power for SIM Card. Automatic detection of SIM card voltage. 3.0V±10% and 1.8V±10%. Maximum supply current is around 10mA.
SIM_DATA	3	SIM Card Data I/O
SIM_CLK	1	SIM Card Clock
SIM_RST	4	SIM Card Reset
SIM_PRESENCE	5	SIM Card Presence Detection
SIM_GND	6	Digital Ground of SIM Card. Separate ground connection for SIM card to improve EMC.



Figure 33 is the reference circuit for SIM interface, and here an 8-pin SIM card holder is used. In order to offer good ESD protection, it is recommended to add TVS such as ST ([www.st.com](http://www.st.com)) ESDA6V1W5 or ON SEMI ([www.onsemi.com](http://www.onsemi.com)) SMF05C. The 22Ω resistors should be added in series between the module and the SIM card so as to suppress the EMI spurious transmission and enhance the ESD protection. The SIM card peripheral circuit should be placed as close as possible to the SIM card socket.

To avoid possible cross-talk from the SIM\_CLK signal to the SIM\_DATA signal be careful that both lines are not placed closely next to each other. A useful approach is using the SIM\_GND line to shield the SIM\_DATA line from the SIM\_CLK line.



**Figure 33: Reference circuit of using 8-pin SIM card socket**

In Figure 33, the pin SIM\_PRESENCE is used to detect whether the tray of the Molex SIM socket, which is used for holding SIM card, is present in the card socket. When the tray is inserted in the socket, SIM\_PRESENCE is at high level. Regardless of whether the SIM card is in the tray or not, the change of SIM\_PRESENCE level from low to high level inspires the module to reinitialize SIM card. Customer's application can use "AT+QSIMDET" to switch on or off the SIM card detection function. For detail of this AT command, please refer to document [1].

If customer doesn't need the SIM card detection function, keep SIM\_PRESENCE open. The reference circuit using a 6-pin SIM card socket illustrates as the following figure.

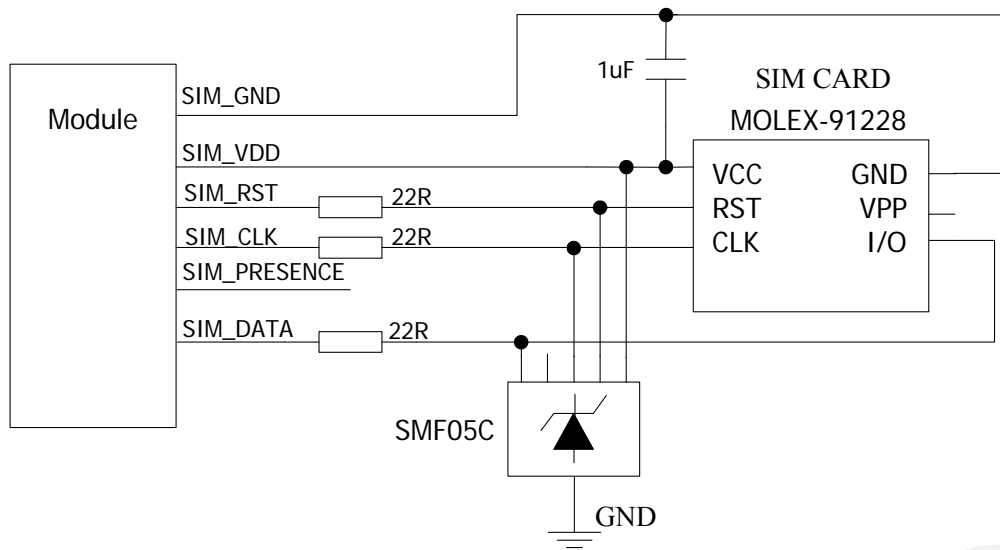


Figure 34: Reference circuit of using 6-pin SIM card socket

### 3.11.2 Design considerations for SIM card holder

For 6-pin SIM card holder, it is recommended to use Amphenol C707 10M006 512 2. Please visit <http://www.amphenol.com> for more information.

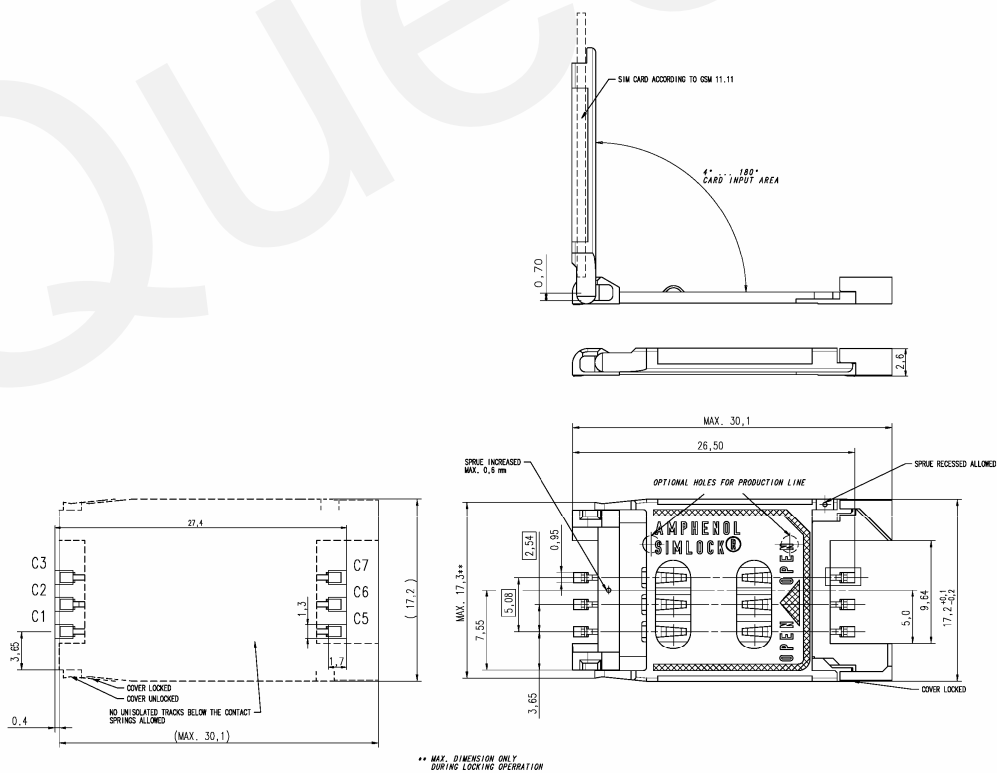
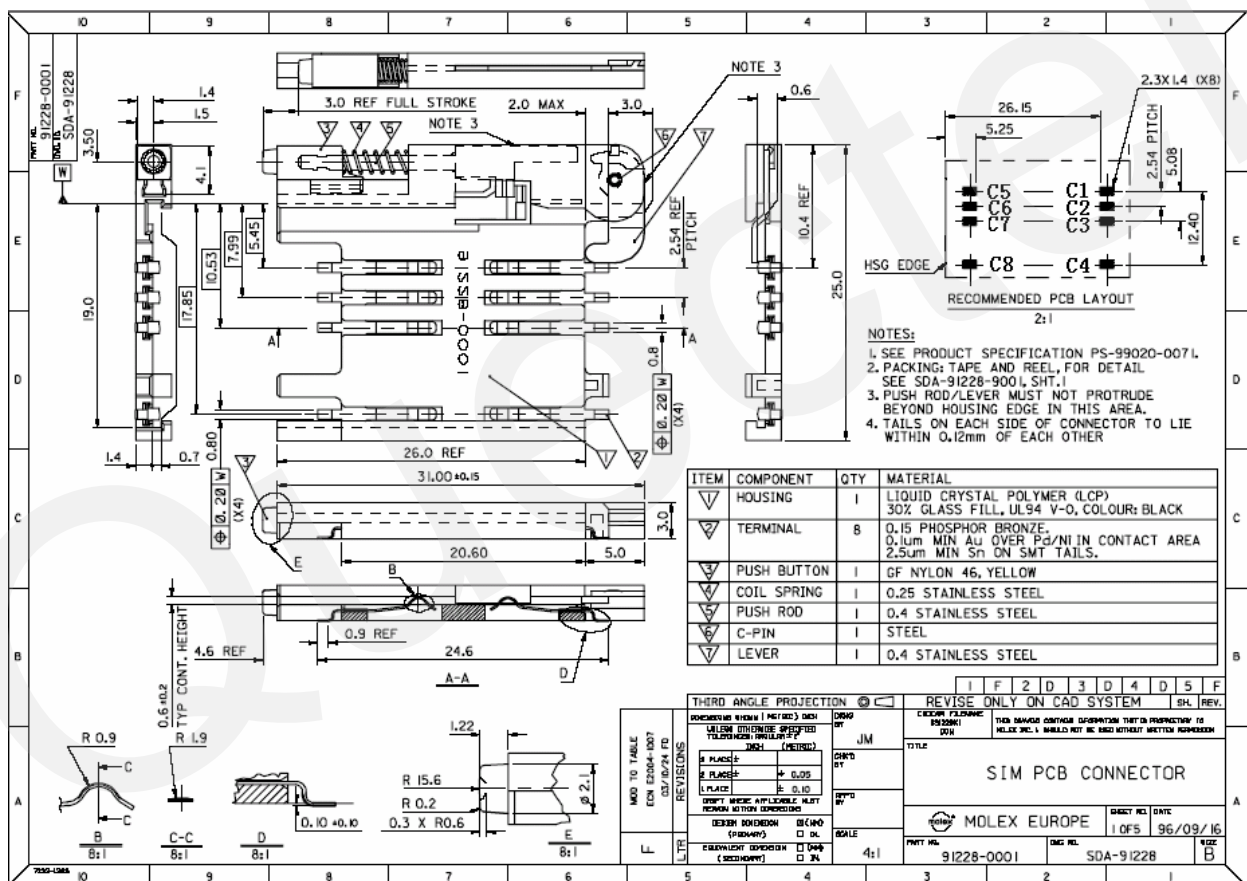


Figure 35: Amphenol C707 10M006 512 2 SIM card holder

**Table 21: Pin description (Amphenol SIM card holder)**

Name	Pin	Function
SIM_VDD	C1	SIM Card Power supply
SIM_RST	C2	SIM Card Reset.
SIM_CLK	C3	SIM Card Clock.
GND	C5	Ground
VPP	C6	Not connect.
SIM_DATA	C7	SIM Card data I/O.

For 8-pin SIM card holder, it is recommended to use Molex 91228. Please visit <http://www.molex.com> for more information.



**Figure 36: Molex 91228 SIM card holder**

**Table 22: Pin description (Molex SIM card holder)**

Name	Pin	Function
SIM_VDD	C1	SIM Card Power supply
SIM_RST	C2	SIM Card Reset
SIM_CLK	C3	SIM Card Clock

GND	C4	
GND	C5	
VPP	C6	Not connect
SIM_DATA	C7	SIM Card data I/O
SIM_PRESENCE	C8	SIM Card Presence detection

### 3.12 ADC

The pin ADC1 can be used to measure analog voltage. Customer can get the measurement result through AT command “AT+QEADC”.

**Table 23: Pin definition of the ADC**

Name	Pin	Function
ADC1	12	Measure analog voltage

**Table 24: Characteristics of the ADC**

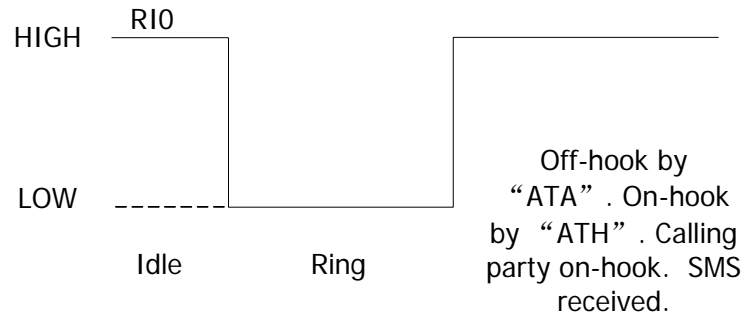
	Min	Typ	Max	Units
Voltage range	0		2.8	V
ADC Resolution	10		10	bits
ADC accuracy		2.7		mV

### 3.13 Behavior of the pin RI0

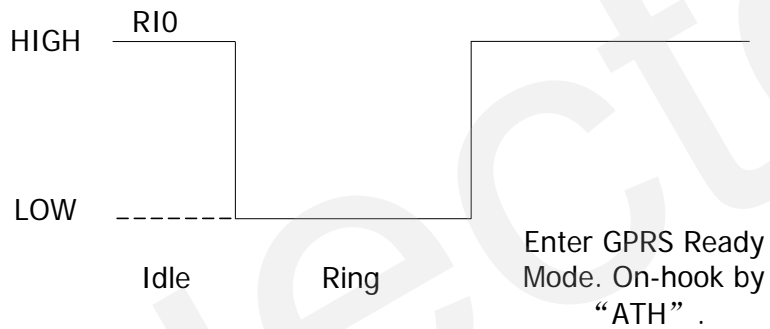
**Table 25: Behaviours of the RI0**

State	RI respond
Standby	HIGH
Voice calling	Change to LOW, then: (1) Change to HIGH when call is established. (2) Use ATH to hang up the call, change to HIGH. (3) Calling part hangs up, change to HIGH. (4) Change to HIGH when SMS is received.
Data calling	Change to LOW, then: (1) Change to HIGH when data connection is established. (2) Use ATH to hang up the call, change to HIGH.
SMS	When a new SMS comes, The RI changes to LOW and holds low level for about 120 ms, then changes to HIGH.
URC	Certain URCs can trigger 120ms low level on RI. For more details, please refer to the <i>document [10]</i>

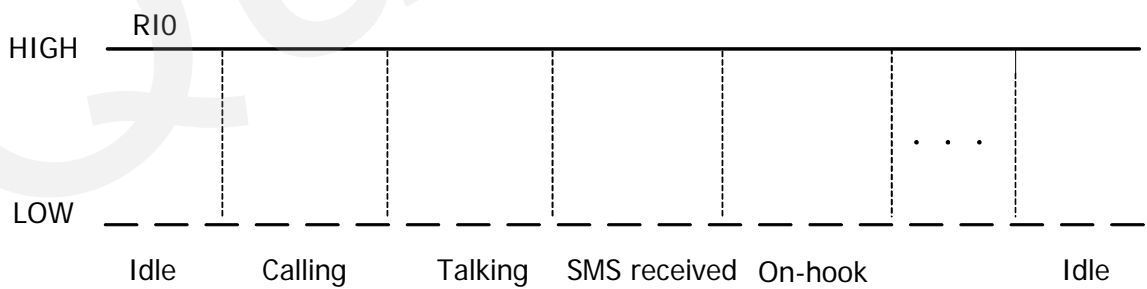
If the module is used as a caller, the RIO would maintain high. On the other hand, when it is used as a receiver, the timing of the RIO is shown below.



**Figure 37: RIO behaviour of voice calling as a receiver**



**Figure 38: RIO behaviour of data calling as a receiver**



**Figure 39: RIO behaviour of data calling as a caller**

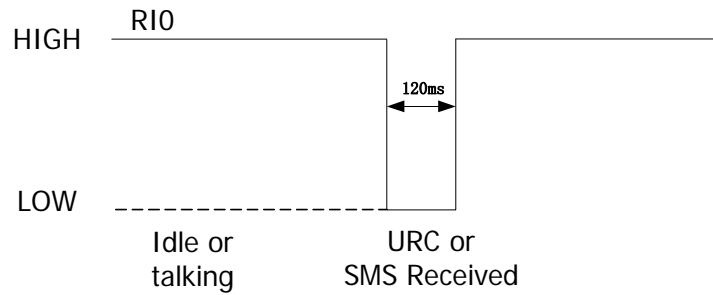


Figure 40: RIO behaviour of URC or SMS received

### 3.14 Network status indication

The NETLIGHT signal can be used to drive a network status indication LED. The working state of this pin is listed in Table 26.

Table 26: Working state of NETLIGHT

State	Module function
Off	The module is not running
64ms On/ 800ms Off	The module is not synchronized with network
64ms On/ 2000ms Off	The module is synchronized with network
64ms On/ 600ms Off	GPRS data transfer is ongoing.

A reference circuit is shown in Figure 41:

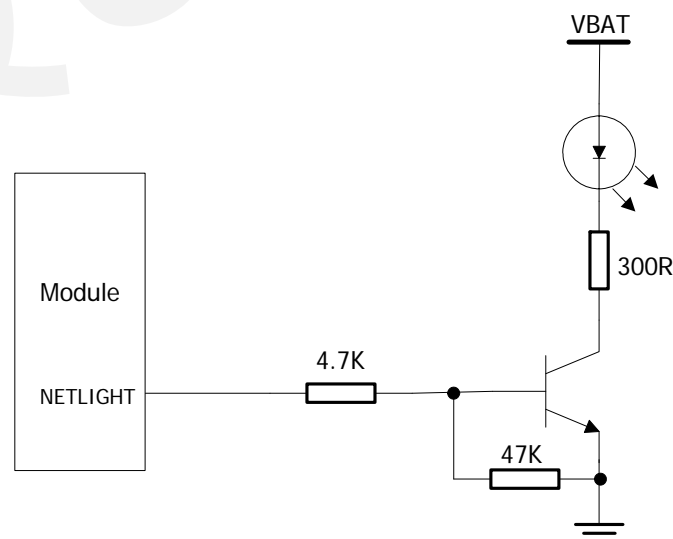


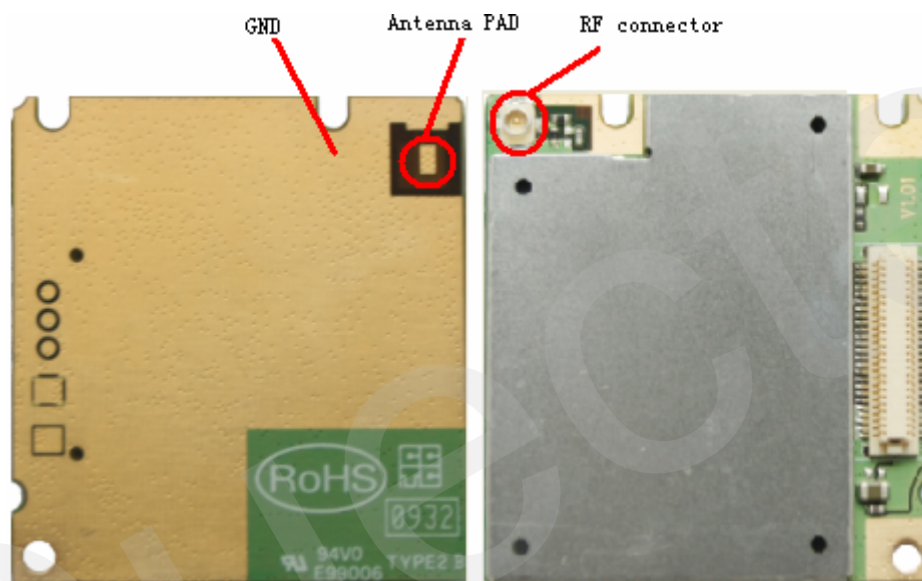
Figure 41: Reference circuit of NETLIGHT

## 4 Antenna interface

The RF interface has an impedance of  $50\Omega$ . To suit the physical design of individual application M20 offers two alternatives:

- Recommended approach: antenna connector at the component side of the PCB (top view on M20).
- Antenna pad and ground plane placed at the bottom side.

When an antenna is connected to the pad, the Hirose connector must be left empty and vice versa. The antenna PAD and RF connector are shown in Figure 42:



**Figure 42: Antenna PAD and RF connector**

To minimize the loss on the RF cable, RF cable should be chosen very carefully. It is recommended that the insertion loss should try to meet the following requirements:

- GSM850/GSM900<1dB
- DCS1800/PCS1900<1.5dB

### 4.1 Antenna installation

#### 4.1.1 Antenna connector

The module adopts Hirose's U.FL-R-SMT RF connector. Customer is recommended to use Hirose's U.FL-LP as the matching connector at the application side. The specification of U.FL-R-SMT is listed in Table 27:

**Table 27: Product specifications of U.FL-R-SMT**

Item	Specification	Condition
Nominal impedance	50 $\Omega$ .	Temperature: -40°C to 90°C
Frequency range	DC to 6GHz.	
Contact resistance	Center: 20m $\Omega$ max. Outer: 10m $\Omega$ max.	10mA max.
Insulation resistance	500 M $\Omega$ min.	100V DC
VSWR	1.5 max	With mated connector
Vibration	No momentary disconnections of 1 $\mu$ s; No damage, cracks and looseness of parts	Frequency of 10 to 100 Hz, single amplitude of 1.5 mm, acceleration of 59m/s <sup>2</sup> , for 5 cycles in the direction of each of the 3 axes
Shock	No momentary disconnections of 1 $\mu$ s; No damage, cracks and looseness of parts	Acceleration of 735m/s <sup>2</sup> , 11ms duration for 6 cycles in the direction of each of the 3 axes
Humidity (Steady state)	No damage, cracks or parts dislocation. Insulation resistance 10M $\Omega$ min.(humidity high) Insulation resistance 500M $\Omega$ min.(dry)	96 hours at temperature of 40°C and humidity of 95%
Temperature cycle	No damage, cracks or parts dislocation. Contact resistance: 25m $\Omega$ max. (Center) 15m $\Omega$ max. (Outer)	Temperature: -40°C $\rightarrow$ +5 to +35°C $\rightarrow$ +90°C $\rightarrow$ +5 to +35°C Time: 30min. $\rightarrow$ 3min. $\rightarrow$ 30min. $\rightarrow$ 3min. 5 cycles
Salt spray	No excessive corrosion	5% salt water solution, 48 hours

For more information about the connector, please contact Hirose dealer or visit the Hirose home page <http://www.hirose-connectors.com>.

#### 4.1.2 Antenna pad

If customer connects antenna to the antenna pad via a soldered microwave coaxial cable, it is suggested to choose the RF cable carefully to minimize the loss on it. And the recommended insertion loss should try to meet the following requirements:

- GSM850/EGSM900 < 0.5dB
- DCS1800/PCS1900 < 1dB

Material properties of the module:

- M20 PCB: FR4
- Antenna pad: Gold plated

Soldering temperature of the antenna pad is recommended to be around 350°C.



*Note: The soldering time for antenna pad and GND pad are different, less than 5s for antenna pad and less than 10s for GND plan.*

## 4.2 RF output power

**Table 28: The module conducted RF output power**

Frequency	Max	Min
GSM850	33dBm $\pm$ 2dB	5dBm $\pm$ 5dB
EGSM900	33dBm $\pm$ 2dB	5dBm $\pm$ 5dB
DCS1800	30dBm $\pm$ 2dB	0dBm $\pm$ 5dB
PCS1900	30dBm $\pm$ 2dB	0dBm $\pm$ 5dB

*Note: Only in GPRS 4 slots TX mode, the max output power is reduced by 2.5dB. That is permitted, as described in chapter 13.16 of 3GPP TS 51.010-1.*

## 4.3 RF receiving sensitivity

**Table 29: The module conducted RF receiving sensitivity**

Frequency	Receive sensitivity
GSM850	< -108.7dBm average
EGSM900	< -108.5dBm average
DCS1800	< -108.5dBm average
PCS1900	< -108.1dBm average

*Note: The antenna chosen will affect radiated receiving sensitivity.*

## 4.4 Operating frequency

**Table 30: The module operating frequency**

Frequency	Receive	Transmit	Channel
GSM850	869 ~ 894MHz	824 ~ 849MHz	128 ~ 251
EGSM900	925 ~ 960MHz	880 ~ 915MHz	0~124, 975~1023
DCS1800	1805 ~ 1880MHz	1710 ~ 1785MHz	512 ~ 885
PCS1900	1930 ~ 1990MHz	1850 ~ 1910MHz	512 ~ 810

## 5 Electrical, reliability and radio characteristics

### 5.1 PIN assignment of the module

Table 31: PIN assignment

PIN NO.	PIN NAME	I/O	PIN NO.	PIN NAME	I/O
1	SIM_CLK	O	50	AGND	
2	SIM_VDD	O	49	SPK2P	O
3	SIM_DATA	I/O	48	SPK1P	O
4	SIM_RST	O	47	SPK1N	O
5	SIM_PRESENCE	I	46	MIC2N	I
6	SIM_GND		45	MIC2P	I
7	RXDDAI	I/O	44	MIC1P	I
8	TFSDAI	O	43	MIC1N	I
9	SCLK	O	42	AGND	
10	TXDDAI	O	41	PWRKEY	I
11	Reserve	O	40	EMERG_OFF	I
12	ADC1	I	39	DCD0	O
13	NETLIGHT	I/O	38	CTS1	O
14	TXD1	O	37	CTS0	O
15	TXD0	O	36	RTS1	I
16	RXD1	I	35	DTR0	I
17	RXD0	I	34	RTS0	I
18	VRTC	I/O	33	Reserve	
19	VCHG	I	32	RI0	O
20	Reserve		31	VDD_EXT	O
21	GND		30	VBAT	I
22	GND		29	VBAT	I
23	GND		28	VBAT	I
24	GND		27	VBAT	I
25	GND		26	VBAT	I

*Note: Please keep all reserved pins open.*

## 5.2 Absolute maximum ratings

The absolute maximum rating for power supply and voltage on digital and analog pins of module are listed in the following table:

**Table 32: Absolute maximum ratings**

Parameter	Min	Max	Unit
VBAT	0	4.7	V
Peak current of power supply	0	2	A
RMS current of power supply (during one TDMA- frame)	0	0.7	A
Voltage at digit pins	-0.3	3.3	V
Voltage at analog pins	-0.3	3.0	V
Voltage at digit/analog pins in POWER DOWN mode	-0.25	0.25	V

## 5.3 Operating temperatures

The operating temperature is listed in the following table:

**Table 33: Operating temperature**

Parameter	Min	Typ	Max	Unit
Normal temperature	-35	25	80	°C
Restricted operation*	-45 to -35		80 to 85	°C
Storage temperature	-45		+90	°C

\* When the module works in this temperature range, the deviations from the GSM specification may occur. For example, the frequency error or the phase error could increase.

## 5.4 Power supply ratings

**Table 34: The module power supply ratings**

Parameter	Description	Conditions	Min	Typ	Max	Unit
VBAT	Supply voltage	Voltage must stay within the min/max values, including voltage drop, ripple, and spikes.	3.4	4.0	4.5	V
	Voltage drop during transmitting burst	Normal condition, power control level for Pout max			400	mV

	Voltage ripple	Normal condition, power control level for Pout max @ f<200kHz @ f>200kHz			50 2	mV	
I <sub>VBAT</sub>	Average supply current	POWER DOWN mode		65		uA	
		SLEEP mode @ DRX=5		1.1		mA	
		Minimum functionality mode AT+CFUN=0					
		IDLE mode		12		mA	
		SLEEP mode		900		uA	
		AT+CFUN=4					
		IDLE mode		12		mA	
		SLEEP mode		1		mA	
		IDLE mode					
GSM850/EGSM 900		12					
DCS1800/PCS1900		12		mA			
TALK mode							
GSM850/EGSM 900 <sup>1)</sup>		250/240		mA			
DCS1800/PCS1900 <sup>2)</sup>		180/195					
DATA mode, GPRS (3 Rx,2Tx)							
GSM850/EGSM 900 <sup>1)</sup>		430/410		mA			
DCS1800/PCS1900 <sup>2)</sup>		290/320					
DATA mode, GPRS (2Rx,3Tx)							
GSM850/EGSM 900 <sup>1)</sup>		560/530		mA			
DCS1800/PCS1900 <sup>2)</sup>		350/400					
DATA mode, GPRS (4 Rx,1Tx)							
GSM850/EGSM 900 <sup>1)</sup>		270/255		mA			
DCS1800/PCS1900 <sup>2)</sup>		200/215					
DATA mode, GPRS (1 Rx,4Tx)							
GSM850/EGSM 900 <sup>1)</sup>		510/530		mA			
DCS1800/PCS1900 <sup>2)</sup>		360/405					
	Peak supply current (during transmission slot)	Power control level for Pout max.		1.6	1.8	A	

<sup>1)</sup> Power control level PCL 5

<sup>2)</sup> Power control level PCL 0

## 5.5 Current consumption

The values for current consumption are shown in Table 35.

**Table 35: The module current consumption**

Condition	Current Consumption
<b>Voice Call</b>	
GSM850	@power level #5 <300mA, Typical 250mA @power level #12, Typical 130mA @power level #19, Typical 95mA
EGSM 900	@power level #5 <300mA, Typical 240mA @power level #12, Typical 130mA @power level #19, Typical 95mA
DCS 1800	@power level #0 <250mA, Typical 180mA @power level #7, Typical 120mA @power level #15, Typical 95mA
PCS 1900	@power level #0 <250mA, Typical 195mA @power level #7, Typical 120mA @power level #15, Typical 95mA
<b>GPRS Data</b>	
DATA mode, GPRS ( 1 Rx, 1 Tx ) CLASS 12	
GSM850	@power level #5 <350mA, Typical 240mA @power level #12, Typical 125mA @power level #19, Typical 90mA
EGSM 900	@power level #5 <350mA, Typical 230mA @power level #12, Typical 120mA @power level #19, Typical 90mA
DCS 1800	@power level #0 <300mA, Typical 170mA @power level #7, Typical 110mA @power level #15, Typical 90mA
PCS 1900	@power level #0 <300mA, Typical 185mA @power level #7, Typical 110mA @power level #15, Typical 90mA
DATA mode, GPRS ( 3 Rx, 2 Tx ) CLASS 12	
GSM850	@power level #5 <550mA, Typical 430mA @power level #12, Typical 230mA @power level #19, Typical 120mA
EGSM 900	@power level #5 <550mA, Typical 410mA @power level #12, Typical 220mA @power level #19, Typical 145mA
DCS 1800	@power level #0 <450mA, Typical 290mA @power level #7, Typical 150mA @power level #15, Typical 140mA
PCS 1900	@power level #0 <450mA, Typical 320mA @power level #7, Typical 170mA @power level #15, Typical 140mA

DATA mode, GPRS ( 2 Rx, 3 Tx ) CLASS 12	
GSM850	@power level #5 <600mA, Typical 560mA @power level #12, Typical 240mA @power level #19, Typical 150mA
EGSM 900	@power level #5 <600mA, Typical 530mA @power level #12, Typical 235mA @power level #19, Typical 150mA
DCS 1800	@power level #0 <490mA, Typical 350mA @power level #7, Typical 180mA @power level #15, Typical 150mA
PCS 1900	@power level #0 <480mA, Typical 400mA @power level #7, Typical 200mA @power level #15, Typical 150mA
DATA mode, GPRS ( 4 Rx, 1 Tx ) CLASS 12	
GSM850	@power level #5 <350mA, Typical 270mA @power level #12, Typical 150mA @power level #19, Typical 115mA
EGSM 900	@power level #5 <350mA, Typical 255mA @power level #12, Typical 145mA @power level #19, Typical 110mA
DCS 1800	@power level #0 <300mA, Typical 200mA @power level #7, Typical 130mA @power level #15, Typical 105mA
PCS 1900	@power level #0 <300mA, Typical 215mA @power level #7, Typical 135mA @power level #15, Typical 110mA
DATA mode, GPRS ( 1 Rx, 4 Tx ) CLASS 12	
GSM850	@power level #5 <660mA, Typical 510mA @power level #12, Typical 300mA @power level #19, Typical 180mA
EGSM 900	@power level #5 <660mA, Typical 530mA @power level #12, Typical 300mA @power level #19, Typical 180mA
DCS 1800	@power level #0 <530mA, Typical 360mA @power level #7, Typical 260mA @power level #15, Typical 160mA
PCS 1900	@power level #0 <530mA, Typical 405mA @power level #7, Typical 260mA @power level #15, Typical 160mA

Class 12 is the default setting. Customer can set it to GPRS Class 10 or Class 8 through AT command. Setting to lower GPRS class would make it easier to design the power supply for the module.

## 5.6 Electro-static discharge

Although the GSM engine is generally protected against Electrostatic Discharge (ESD), ESD protection precautions should still be emphasized. Proper ESD handling and packaging procedures must be applied throughout the processing, handling and operation of any application using the module.

The measured values of module are shown as the following table:

**Table 36: The ESD endurance (Temperature: 25°C, Humidity: 45 %)**

Part	Contact discharge	Air discharge
VBAT,GND	±5KV	±10KV
PWRKEY	±4KV	±8KV
Antenna port	±5KV	±10KV
SPK1P/1N, SPK2P/2N, MIC1P/1N, MIC2P/2N	±4KV	±8KV

## 6 Product information

**Table 37: Ordering information**

Description	Part Number	Frequency Band	RF Function
M20	Q1-M20TM	GSM850 EGSM900 DCS1800 PCS1900	GSM/GPRS



## 7 Mechanical dimension

This chapter describes the mechanical dimensions of the module.

### 7.1 Mechanical dimensions of module

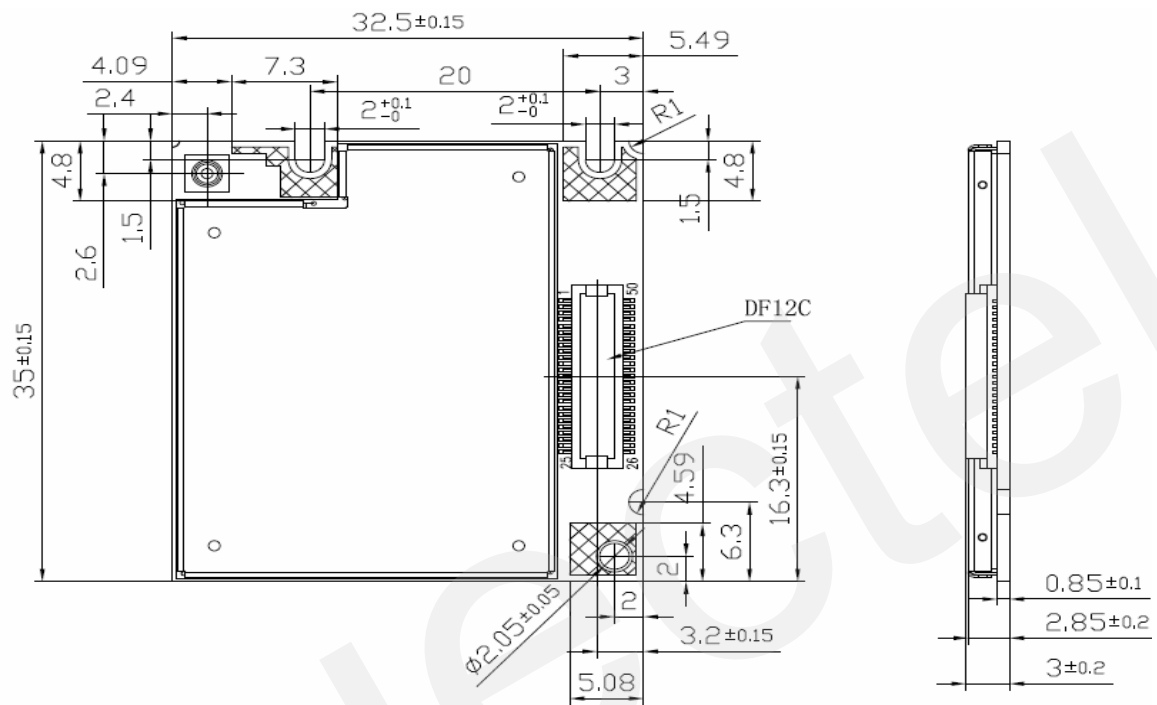


Figure 43: M20 TOP and SIDE dimensions (Unit: mm)

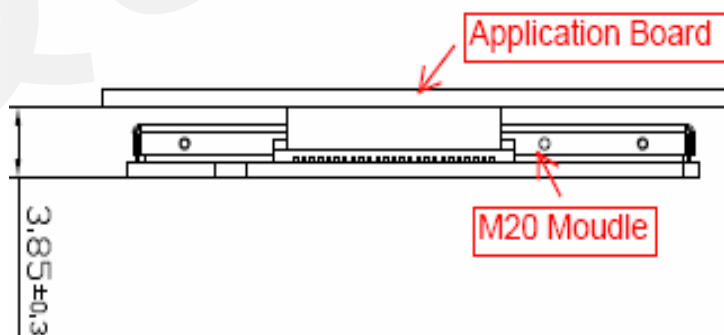


Figure 44: M20 module matches with the application board (Unit: mm)

## 7.2 Footprint of recommendation

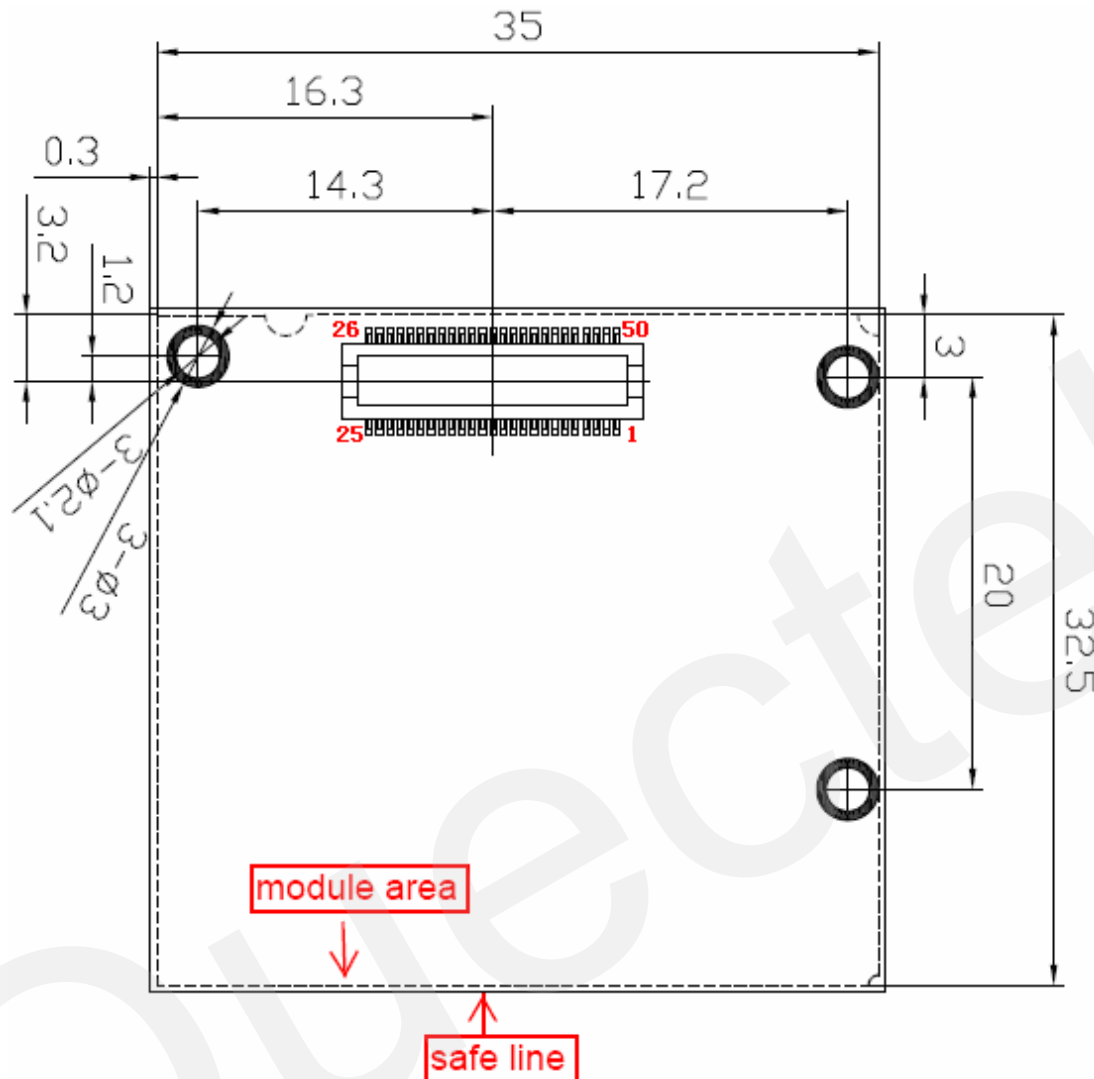


Figure 45: Footprint of recommendation (Unit: mm)

## 7.3 Mounting module in the host

There are many ways to properly install the module in the host device. An efficient approach is to mount the M20 module to a frame, plate, rack or chassis.

Fasteners can be M20 screws plus suitable washers, circuit board spacers, or customized screws, clamps, or brackets. Screws must be inserted with the screw head on the bottom of the M20 module. In addition, the B2B connection can also be utilized to achieve better support.

To prevent mechanical damage, be careful not to force, bend or twist the module. Be sure it is positioned flat against the host device.

### 7.3.1 Board-to-board connector

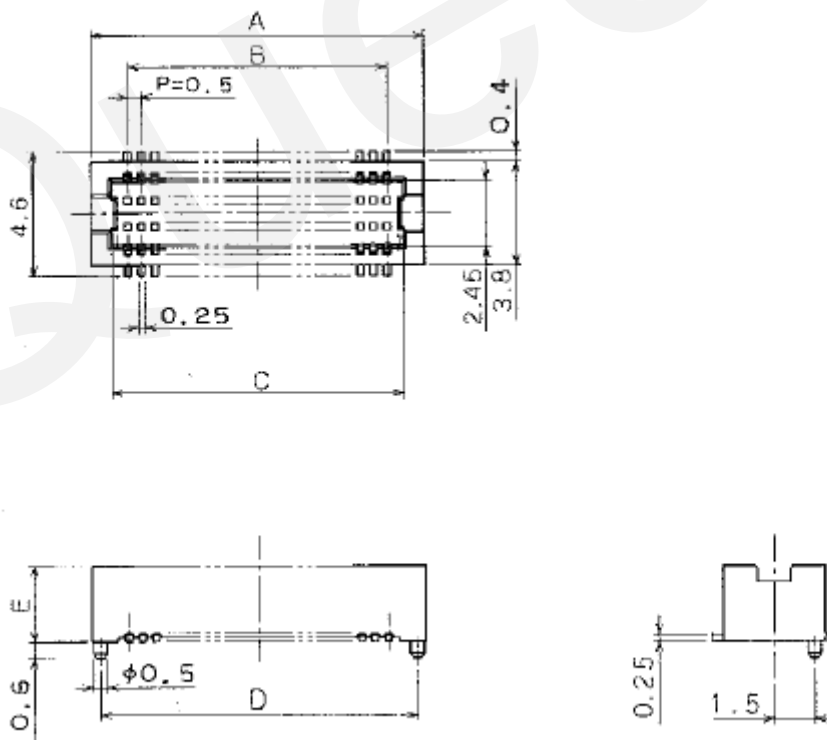
This section provides specifications for the 50-pin board-to-board connector which serves as physical interface to the host application. The receptacle assembled on the M20 module is type Hirose DF12C or DF12A. Mating headers from Hirose are available in different stacking heights.

**Table 38: Ordering information DF12 series**

Item	Part number	Stacking height	HRS number
Receptacle on M20	DF12A(3.0)-50DS-0.5V(81)	3.0	537-0634-7-81
	DF12C(3.0)-50DS-0.5V(81)	3.0	537-0694-9-81
Headers DF12 series	DF12E(3.0)-50DP-0.5V(81)	3.0	537-0834-6-**
	DF12E(3.5)-50DP-0.5V(81)	3.5	537-0534-2-**
	DF12E(4.0)-50DP-0.5V(81)	4.0	537-0559-3-**
	DF12E(5.0)-50DP-0.5V(81)	5.0	537-0584-0-**

*Note: Please contact Hirose for details on other types of mating headers. Asterixed HRS numbers denote different types of packaging.*

### 7.3.2 Mechanical dimensions of the DF12 header (without metal fitting)



**Figure 46: Dimensions of the DF12 header (Unit: mm)**

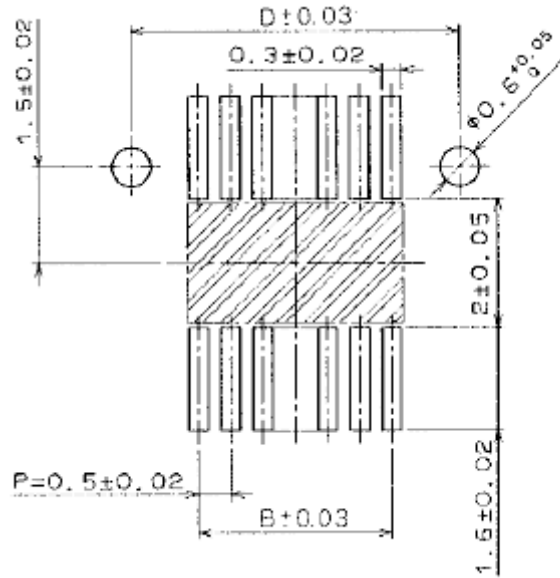
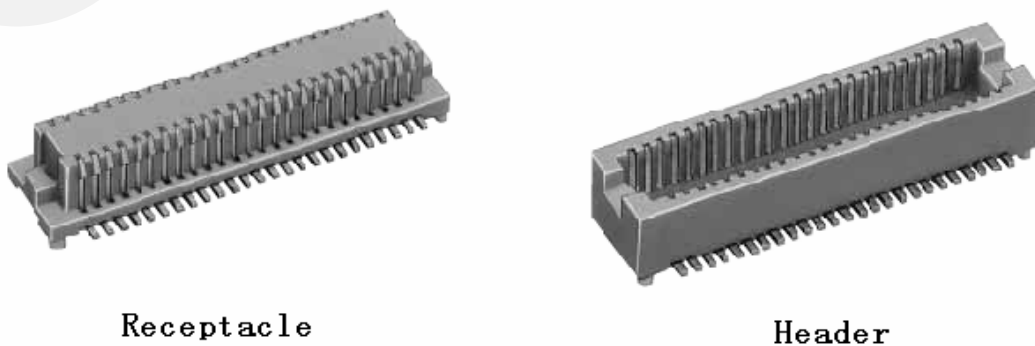


Figure 47: Footprint of recommendation (Unit: mm)

Table 39: Dimensions of DF12 connector

Part number	CL No.	Pin number	A	B	C	D	E	Remarks
DF12E (3.0)-50DP-0.5V(81)	537-0834-6- 81	50	14.7	12.0	13.2	-	2.3	Without metal fitting Without boss
DF12E (3.5)-50DP-0.5V (81)	537-0534-2- 81	50	14.7	12.0	13.2	-	2.8	
DF12E (4.0)-50DP-0.5V (81)	537-0559-3- 81	50	14.7	12.0	13.2	-	3.3	
DF12E (5.0)-50DP-0.5V (81)	537-0584-0- 81	50	14.7	12.0	13.2	-	4.3	

7.3.3 Physical photo of the DF12 connector



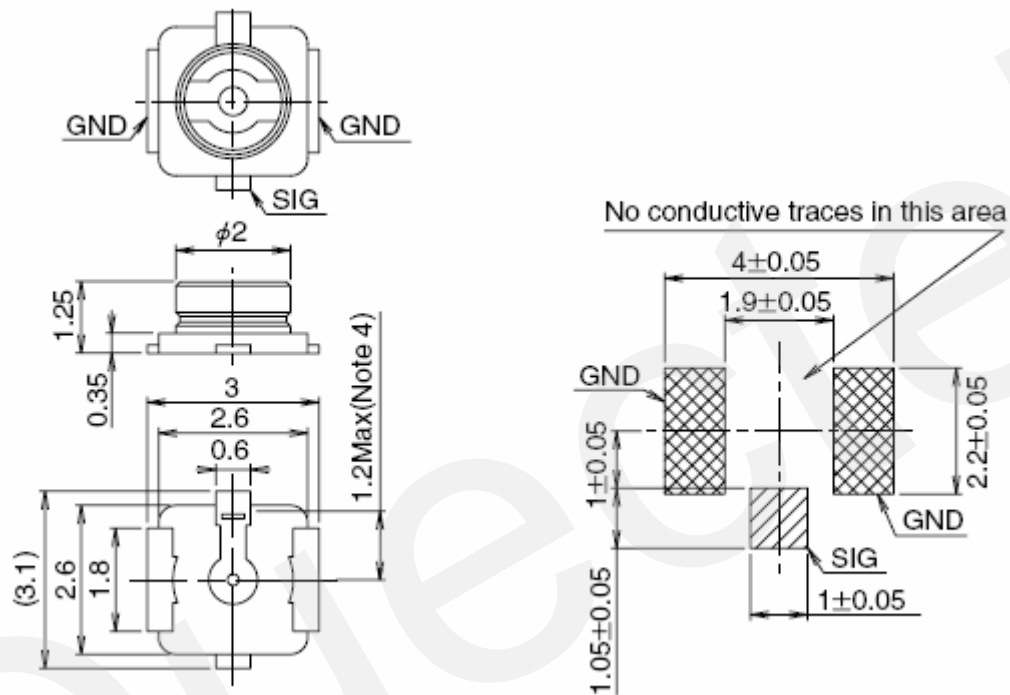
Receptacle

Header

Figure 48: Physical photos of the DF12 connectors

**Note :**

The receptacle connector is used at the module side and the header connector is used at the host PCB side.

**7.4 RF connector****7.4.1 Physical photo of the UF.L-R-SMT connector**

**Figure 49: Physical photos of the UF.L-R-SMT connector (Unit: mm)**

**7.4.2 Matching connector on the application side of M20**

Five types of female connector can match UF.L-R-SMT. The mechanicals of them are listed in the following figure:

Part No.	U.FL-LP-040	U.FL-LP-066	U.FL-LP(V)-040	U.FL-LP-062	U.FL-LP-088
Mated Height	2.5mm Max. (2.4mm Nom.)	2.5mm Max. (2.4mm Nom.)	2.0mm Max. (1.9mm Nom.)	2.4mm Max. (2.3mm Nom.)	2.4mm Max. (2.3mm Nom.)
Applicable cable	Dia. 0.81mm Coaxial cable	Dia. 1.13mm and Dia. 1.32mm Coaxial cable	Dia. 0.81mm Coaxial cable	Dia. 1mm Coaxial cable	Dia. 1.37mm Coaxial cable
Weight (mg)	53.7	59.1	34.8	45.5	71.7
RoHS	YES				

Figure 50: Mechanicals of UF.L-LP connectors

7.4.3 Space factor of mated connector

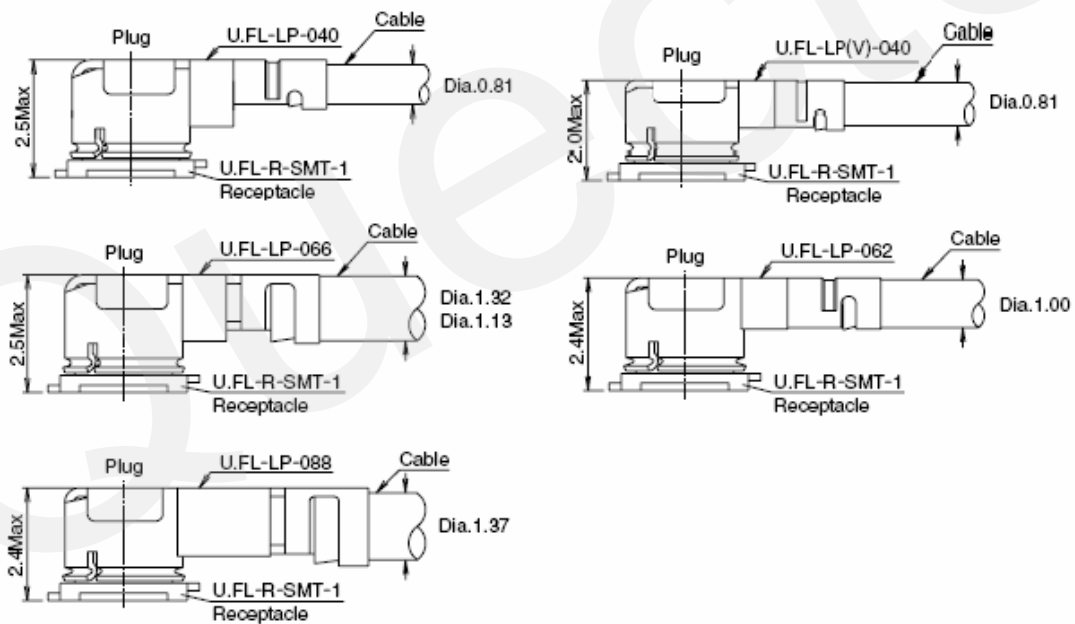


Figure 51: Space factor of mated connector (Unit: mm)

### 7.5 Top view of the module



Figure 52: Top view of the module

### 7.6 Bottom view of the module



Figure 53: Bottom view of the module

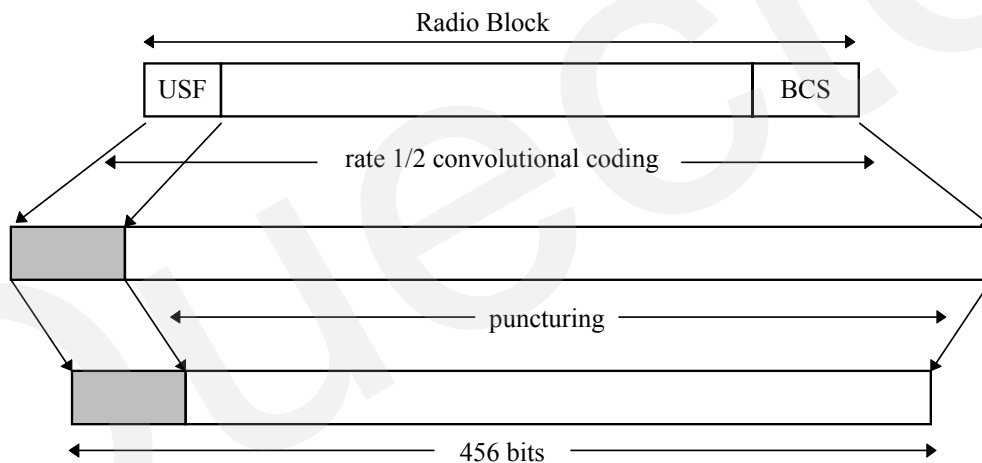
## Appendix A: GPRS Coding Schemes

Four coding schemes are used in GPRS protocol. The differences between them are shown in Table 40.

**Table 40: Description of different coding scheme**

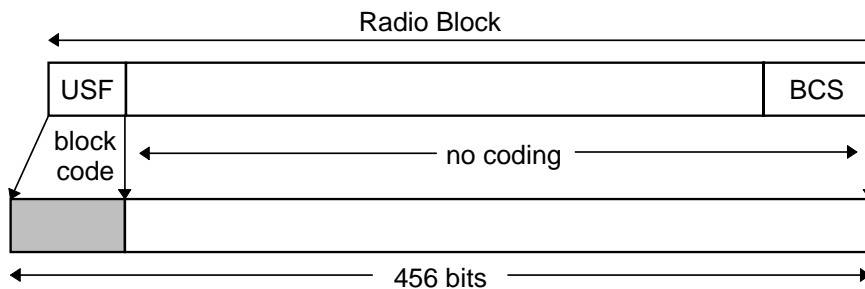
Scheme	Code rate	USF	Pre-coded USF	Radio Block excl.USF and BCS	BCS	Tail	Coded bits	Punctured bits	Data rate Kb/s
CS-1	1/2	3	3	181	40	4	456	0	9.05
CS-2	2/3	3	6	268	16	4	588	132	13.4
CS-3	3/4	3	6	312	16	4	676	220	15.6
CS-4	1	3	12	428	16	-	456	-	21.4

Radio block structure of CS-1, CS-2 and CS-3 is shown as Figure 54:



**Figure 54: Radio block structure of CS-1, CS-2 and CS-3**

Radio block structure of CS-4 is shown as Figure 55:



**Figure 55: Radio block structure of CS-4**



## Appendix B: GPRS Multi-slot Classes

Twenty-nine classes of GPRS multi-slot modes are defined for MS in GPRS specification. Multi-slot classes are product dependant, and determine the maximum achievable data rates in both the uplink and downlink directions. Written as 3+1 or 2+2, the first number indicates the amount of downlink timeslots, while the second number indicates the amount of uplink timeslots. The active slots determine the total number of slots the GPRS device can use simultaneously for both uplink and downlink communications. The description of different multi-slot classes is shown in Table 41.

**Table 41: GPRS multi-slot classes**

Multislot class	Downlink slots	Uplink slots	Active slots
1	1	1	2
2	2	1	3
3	2	2	3
4	3	1	4
5	2	2	4
6	3	2	4
7	3	3	4
8	4	1	5
9	3	2	5
10	4	2	5
11	4	3	5
12	4	4	5
13	3	3	NA
14	4	4	NA
15	5	5	NA
16	6	6	NA
17	7	7	NA
18	8	8	NA
19	6	2	NA
20	6	3	NA
21	6	4	NA
22	6	4	NA
23	6	6	NA
24	8	2	NA
25	8	3	NA
26	8	4	NA
27	8	4	NA
28	8	6	NA
29	8	8	NA

# QUECTEL



**Shanghai Quectel Wireless Solutions Co., Ltd.**

Room 801, Building E, No.1618, Yishan Road, Shanghai, China 201103

Tel: +86 21.5108 2965

Mail: [info@quectel.com](mailto:info@quectel.com)