

Silica Xynergy-M4 Board

STM32 meets Spartan-6

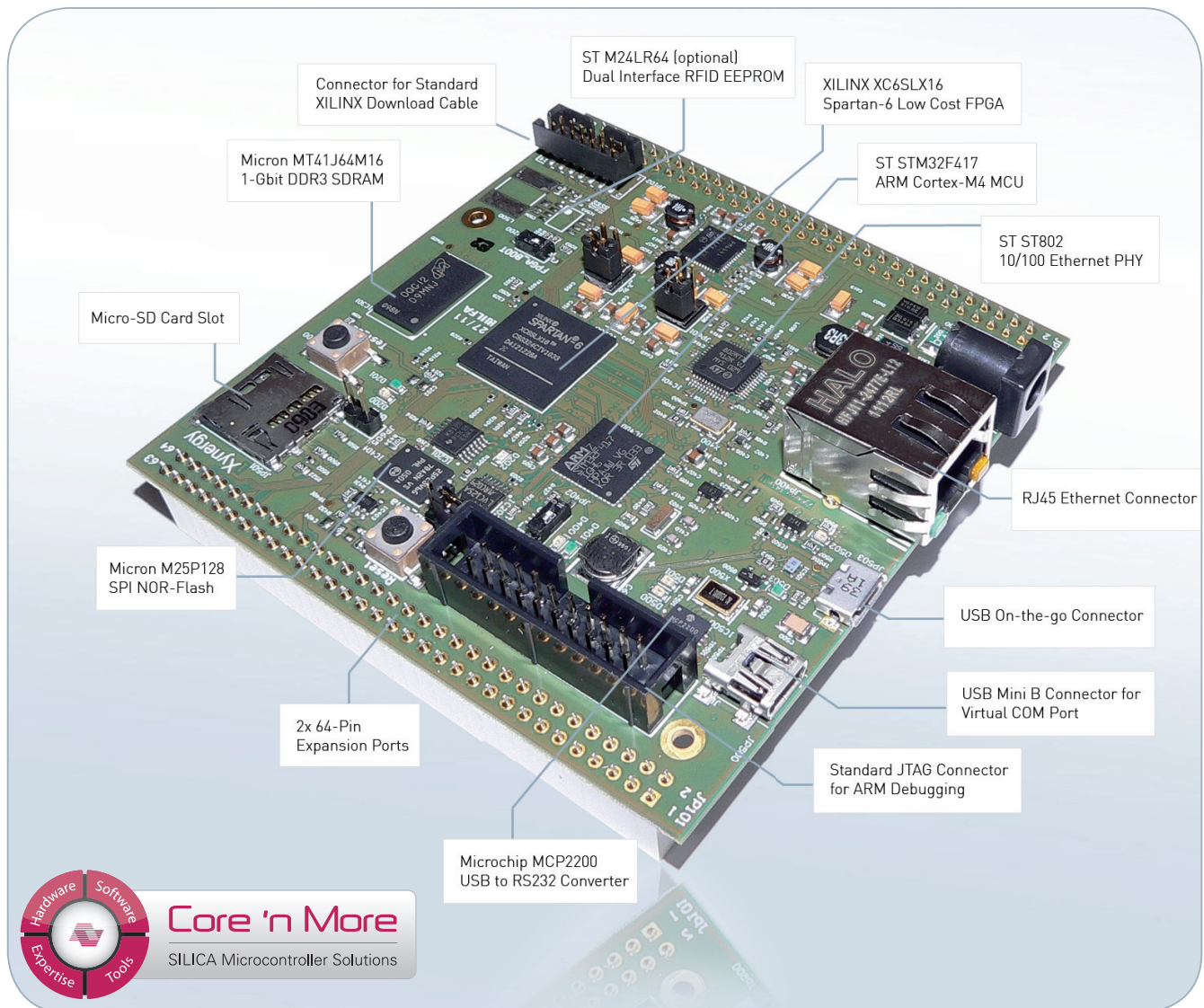

The Silica Xynergy-M4 Board combines an ARM Cortex-M4 based STMicroelectronics STM32F417 controller with a Xilinx Spartan-6 low-cost FPGA (XC6SLX16) in one design.

There are numerous development tools for either ARM Cortex-M microcontrollers or FPGA kits, but this is the first module in the market that merges both technologies on one board.

Ordering Information:

XYZBAYXYNERGYM4

€ 209.-

For further details, please visit:
www.silica.com/xynergy-m4

Target Applications

- Evaluation of mixed microcontroller/ FPGA designs
- General purpose industrial applications using Ethernet/ USB/ CAN/ SPI/ I²C
- General purpose pre-, post- and co-processing with FPGA, i.e. digital filtering, advanced crypto, video etc.
- Implementation of industrial Ethernet IP in FPGA
- Motor control with FPGA acceleration of closed loop algorithms
- Access to DDR3 memory for the STM32
- Custom interfaces

Kit Content

- Silica Xynergy Board
- ST-LINK/V2 in-circuit debugger/ programmer for STM32
- 5 V/3 A Power adapter
- Cat-5 Patch Cable
- USB 2.0 Cable A/ mini B for Virtual COM-port connection

Block Diagram

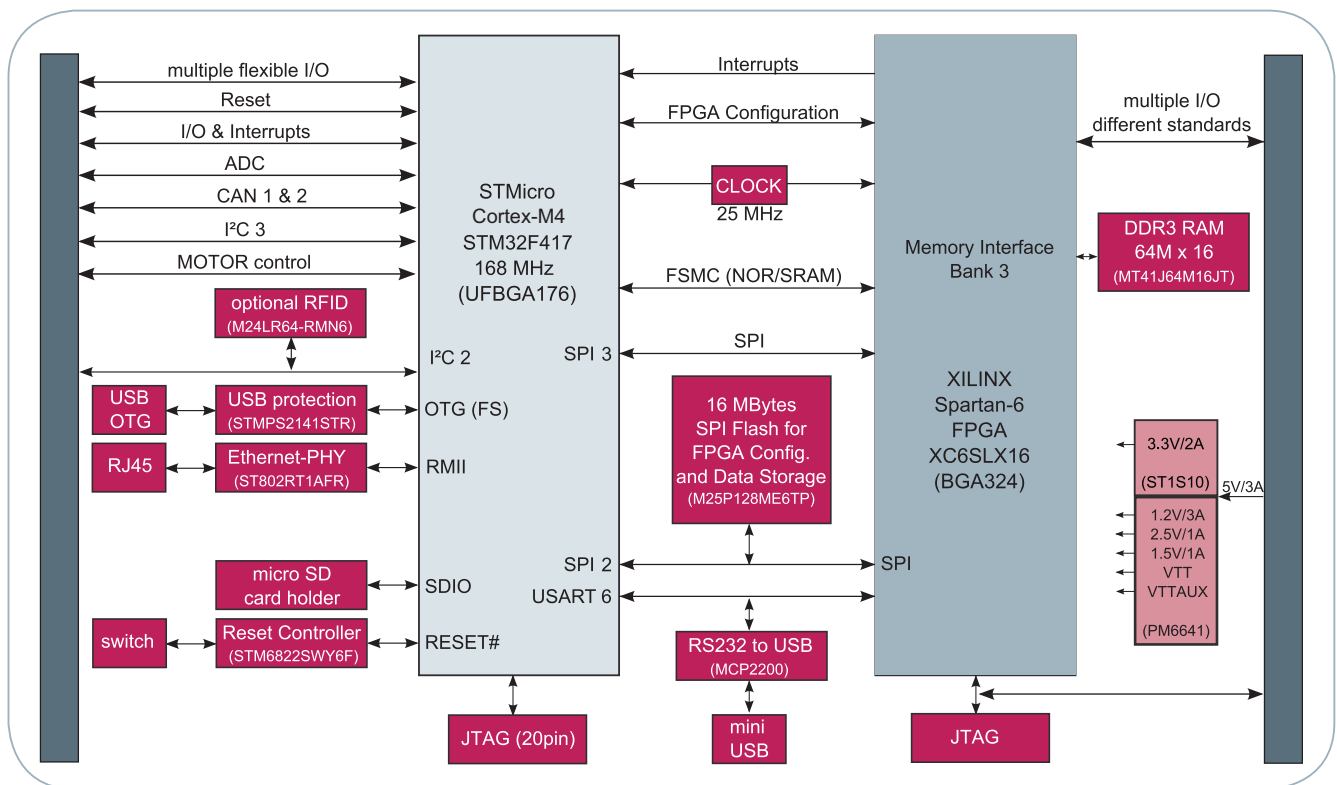

Getting Started

The Getting Started documentation, including links to compatible development tools with free options, the user manual, software examples and any additional documentation is available for download from: www.silica.com/xynergy-m4