

Page 2

LPC3154 Powering and Unused parts

Page 3

LPC3154 Digital I/O

Page 4

JTAG Interface

Page 5

LPC17XX with Expansion connector

Page 6

LPC17XX

Design Overview

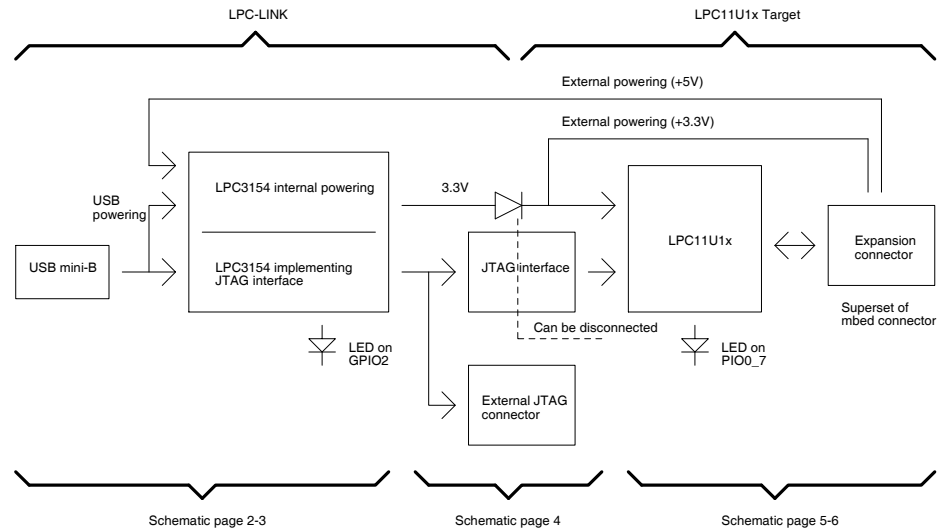

UL = UnLoaded = normally not mounted component.

Default jumper settings are indicated in the schematic. However, always check jumper positions on actual boards since there is no guarantee that all jumpers are in default place.



(C) Embedded Artists AB

TITLE: LPCxpresso LPC11U14 rev A

Document Number: REU:

Date: 2/17/2011 8:34:11 PM Sheet: 1/6

Note: 1V8 rail is actually 1.4V since internal regulator in default

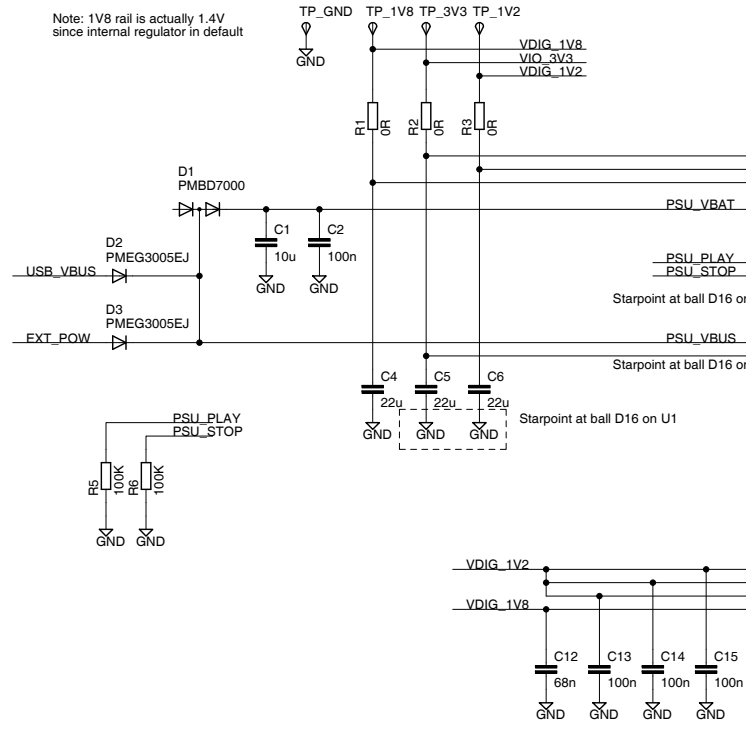

Power supply parts of LPC3154

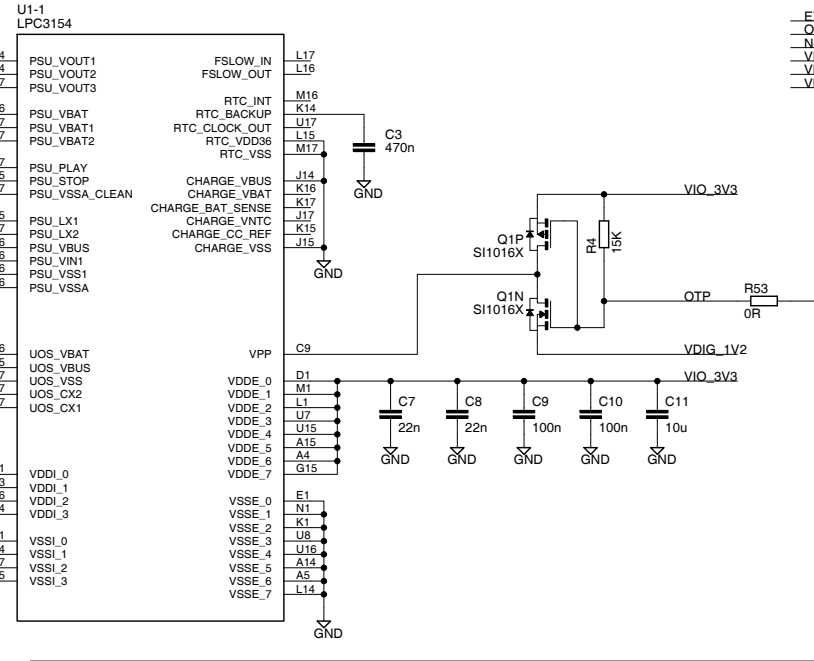

Production test connector

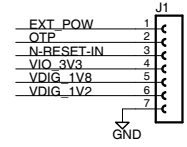

Analog parts of LPC3154

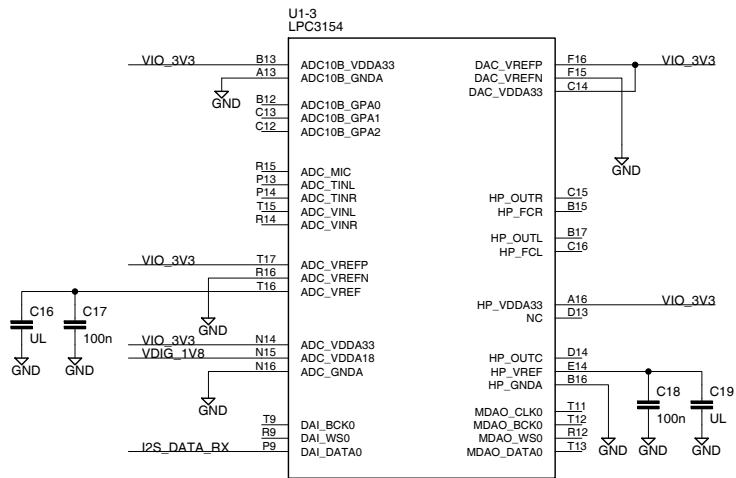

Not used parts of LPC3154

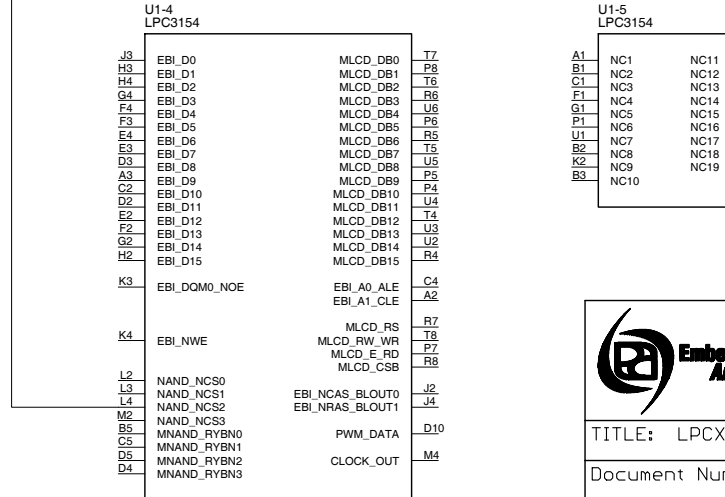

(C) Embedded Artists AB

TITLE: LPCxpresso LPC11U14 rev A

Document Number: _____ REV: _____



Date: 2/17/2011 8:34:11 PM Sheet: 2/6

Boot mode - USB via DFU class

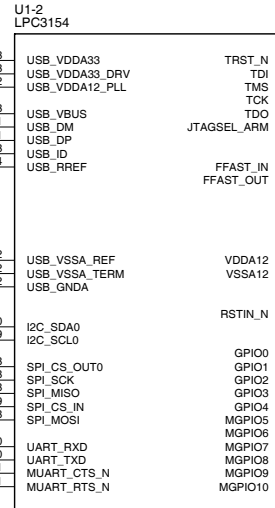
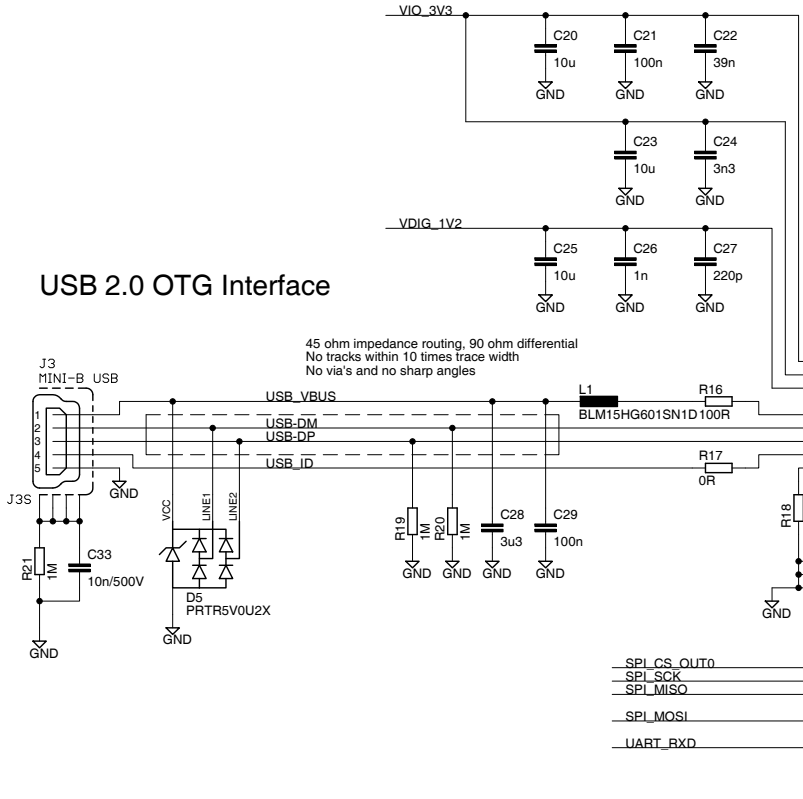
USB 2.0 OTG Interface

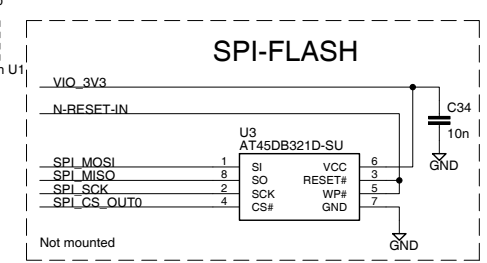
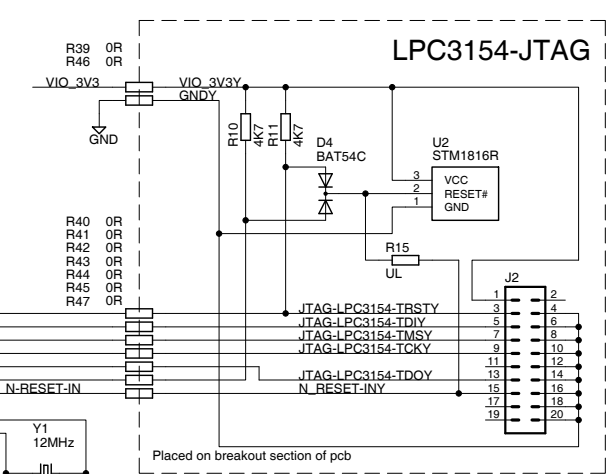
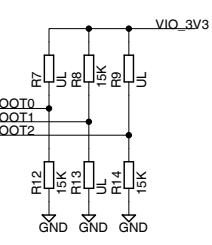
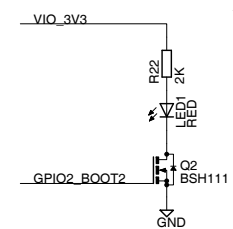

LED





(C) Embedded Artists AB

TITLE: LPCxpresso LPC11U14 rev A

Document Number:	REU:
Date: 2/17/2011 8:34:11 PM	Sheet: 3/6

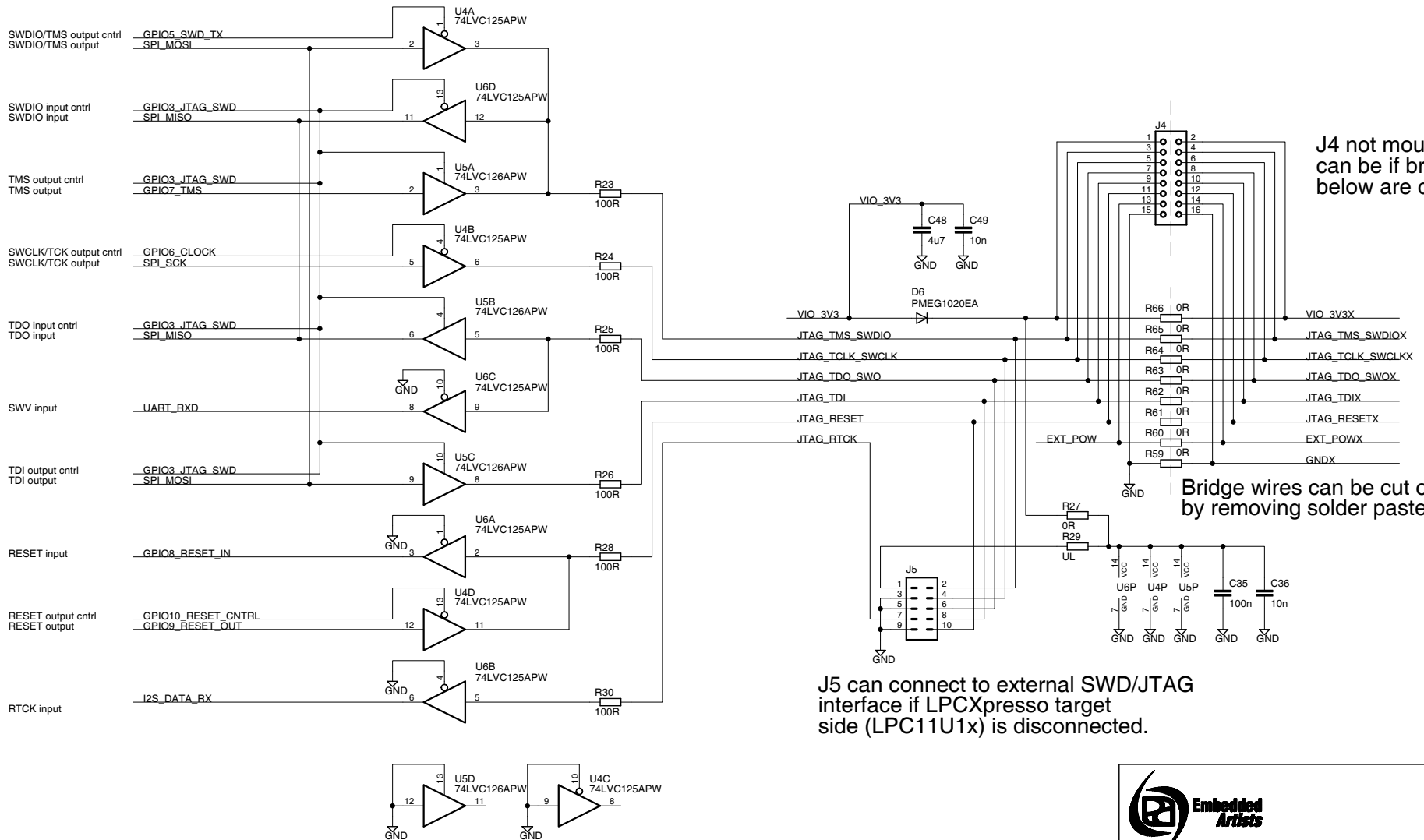
SWD/JTAG Interface



J4 not mounted, but can be if bridge wires below are cut.

Bridge wires can be cut on pcb by removing solder paste.

J5 can connect to external SWD/JTAG interface if LPCXpresso target side (LPC11U1x) is disconnected.



(C) Embedded Artists AB

TITLE: LPCXpresso LPC11U14 rev A

Document Number:	REU:
Date: 2/17/2011 8:34:11 PM	Sheet: 4/6

LPC11U14 Target Side

From LPC-LINK Side

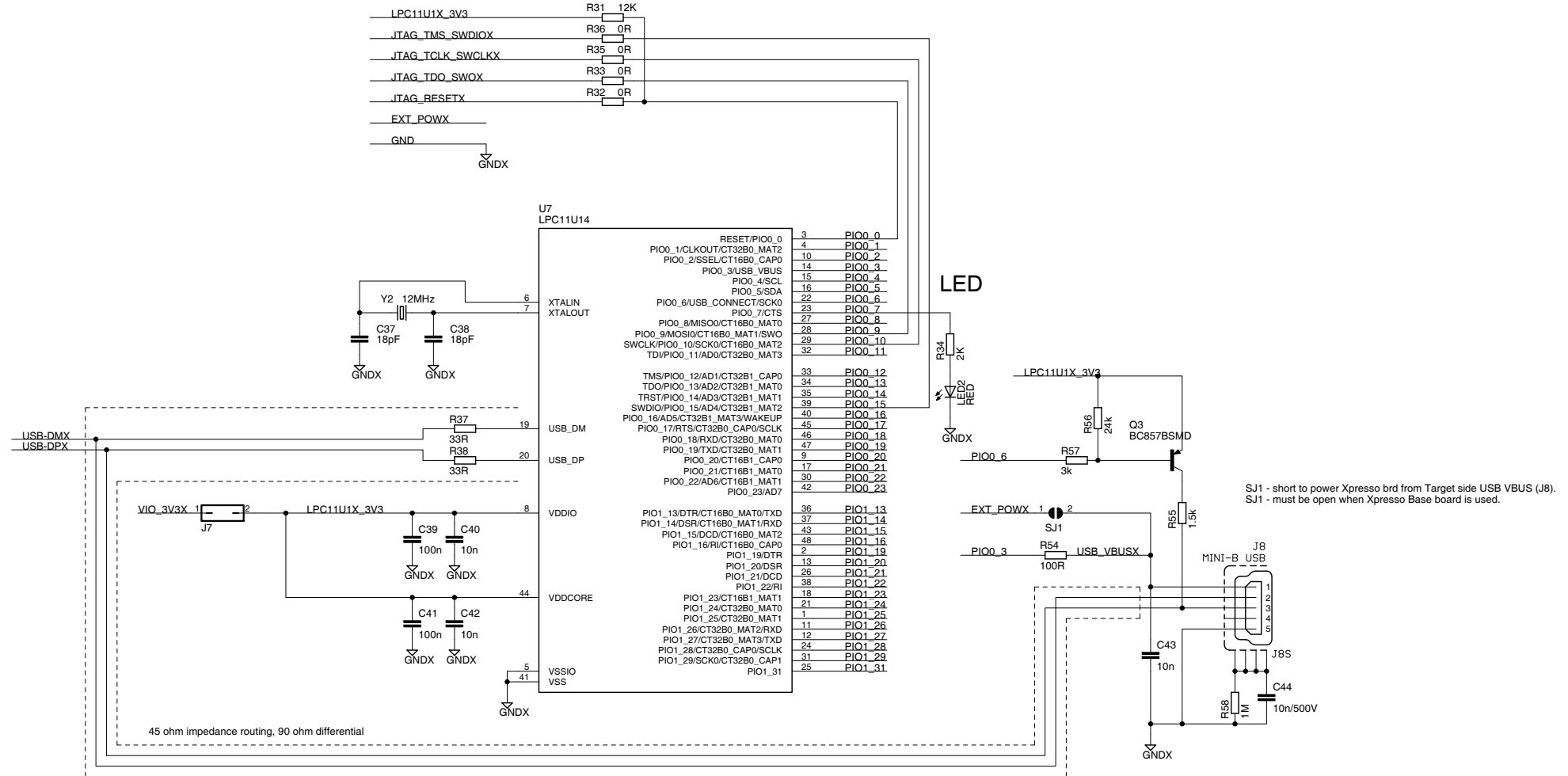



(C) Embedded Artists AB

TITLE: LPCxpresso LPC11U14 rev A	
Document Number:	REU:
Date: 2/17/2011 8:34:11 PM	Sheet: 5/6

↑
LPC-LINK side

Expansion Connector (superset of mbed pinning)

mbed	LPCXpresso
GND	GND
VIN (4.5-14V)	VIN (4.5-5.5V)
VB (battery supply)	not used
nR (reset)	PIO0_0 RESET
SPI1-MOSI	PIO0_9 MOSI0/SWO
SPI1-MISO	PIO0_8 MISO0
SPI1-SCK	PIO1_29 SCK0
GPIO	PIO0_2 SSEL0
UART1-TX / I2C1-SDA	PIO0_19 TXD
UART1-RX / I2C1-SCL	PIO0_18 RXD
SPI2-MOSI	PIO0_7
SPI2-MISO	PIO1_19
SPI2-SCL / UART2-TX	PIO1_20
UART2-RX	PIO1_21
AIN0	PIO0_11 AD0
AIN1	PIO0_12 AD1
AIN2	PIO0_13 AD2
AIN3 / AOUT	PIO0_14 AD3
AIN4	PIO0_15 AD4/SWDIO
AIN5	PIO0_16 AD5
	PIO0_17
	PIO0_20
	PIO0_6 USB_SOFT_CONN
	PIO0_10 SWCLK
	PIO1_13
	PIO1_14
	PIO1_15

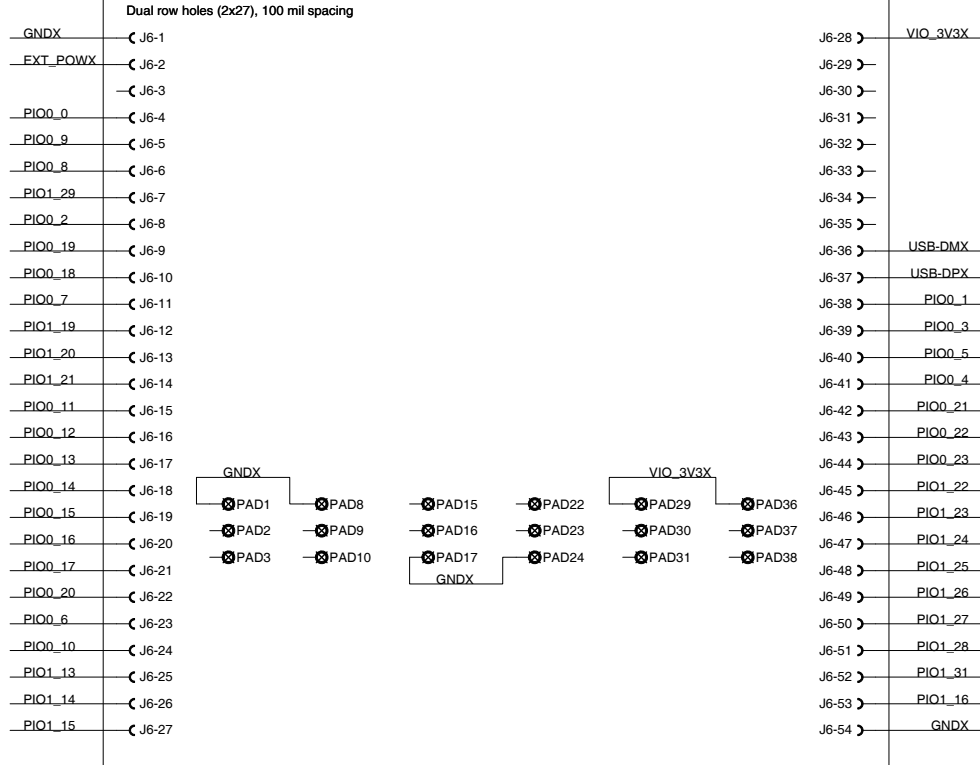

LPCXpresso	mbed
VOUT (+3.3V out) if self powered, else +3.3V input	VOUT (3.3V out)
not used	VU (5.0V USB out)
not used	IF+
not used	IF-
not used	RD- (Ethernet)
not used	RD+ (Ethernet)
not used	TD- (Ethernet)
not used	TD+ (Ethernet)
USB-DM	D- (USB)
USB-DP	D+ (USB)
PIO0_1	CAN-RD
PIO0_3	USB-VBUS
PIO0_5	I2C-SDA
PIO0_4	I2C-SCL
PIO0_21	MAT=PWM
PIO0_22	MAT=PWM
PIO0_23	PWMOUT2
PIO1_22	PWMOUT3
PIO1_23	PWMOUT4
PIO1_24	PWMOUT5
PIO1_25	
PIO1_26	
PIO1_27	
PIO1_28	
PIO1_31	
PIO1_16	
GND	



(C) Embedded Artists AB

TITLE: LPCXpresso LPC11U14 rev A

Document Number: REU:

Date: 2/17/2011 8:34:11 PM Sheet: 6/6