



## **1 Introduction**

The STM32W-RFCKIT low-cost RF control kit is an easy-to-use tool for STM32W108xx RF microcontrollers. This family of microcontrollers integrates a 32-bit ARM® Cortex™-M3 microprocessor and a 2.4 GHz, IEEE 802.15.4-compliant transceiver. The kit demonstrates plug and play 2.4 GHz RF point-to-point communications targeting general-purpose wireless control systems.

The STM32W-RFCKIT RF control kit provides demonstration applications and documentation which serve as a reference for creating your own applications and re-programming the STM32W108xx microcontroller.

You can run the STM32W-RFCKIT RF control kit in several ways using the dedicated software libraries (Simplified MAC, ZigBee RF4CE and ZigBee PRO). This kit provides access to a set of straightforward HAL APIs enabling application engineers to easily develop RF control capabilities such as LEDs, serial communication channels (virtual COM through USB), MEM enabled pointers, etc. Moreover, thanks to the flexibility of STM32W microcontrollers, developers will also be able to use the kit with other available protocol network libraries: MAC based, RF4CE, ZigBee PRO or 6LowPan.

This manual provides information about:

- STM32W-RFCKIT RF control kit components
- How to install the related hardware, software and documentation trees
- How to run the preprogrammed demonstration applications

*Note:* For more information, visit the STM32W 32-bit RF microcontroller webpages at [www.st.com/stm32w\\_rfcontrol](http://www.st.com/stm32w_rfcontrol)

*These webpages provide full access to all STM32W108xx resources (kits, software packages and documents).*

# Contents

- 1 Introduction ..... 1**
- 2 Getting started ..... 4**
  - 2.1 Kit description ..... 4
    - 2.1.1 Hardware ..... 4
  - 2.2 MB950 hardware description ..... 4
    - 2.2.1 MB950 resources ..... 4
    - 2.2.2 MB950 connectors ..... 5
    - 2.2.3 MB950 connectors: P1 pins ..... 5
    - 2.2.4 MB950 jumper configuration ..... 5
    - 2.2.5 MB950 PC interface chip ..... 6
    - 2.2.6 MB950 battery holder ..... 6
  - 2.3 MB951 hardware description ..... 6
    - 2.3.1 MB951 resources ..... 6
    - 2.3.2 MB951 connectors ..... 6
    - 2.3.3 MB951 jumper configuration ..... 6
    - 2.3.4 MB951 PC interface chip ..... 7
    - 2.3.5 MB951 battery holder ..... 7
  - 2.4 Software ..... 7
  - 2.5 Documentation ..... 7
  - 2.6 Software libraries and demonstration applications ..... 7
  - 2.7 Kit setup ..... 8
    - 2.7.1 Powering on the boards ..... 8
    - 2.7.2 Installing the ST Virtual COM port driver USB drive ..... 8
    - 2.7.3 Setting up the application serial communication channel ..... 8
- 3 Running the STM32W-RFCKIT RF control kit ..... 9**
  - 3.1 Installing the STM32W-RFCKIT RF control kit software tree ..... 9
    - 3.1.1 Building and download the Simple MAC talk demonstration application . 9
    - 3.1.2 Basic RF communication using the talk demonstration application . . . . 10
- 4 STM32W-RFCKIT utilities and software tools ..... 11**
  - 4.1 stm32w\_flasher utility ..... 11

---

<b>5</b>	<b>List of acronyms</b> .....	<b>12</b>
<b>Appendix A</b>	<b>Available board schematics</b> .....	<b>13</b>
<b>6</b>	<b>Revision history</b> .....	<b>16</b>

## 2 Getting started

This section provides a complete description of the STM32W-RFCKIT RF control kit's hardware and software.

### 2.1 Kit description

#### 2.1.1 Hardware

The STM32W-RFCKIT RF control kit's package contains the following hardware components:

- One STM32W108xx MB950 remote application board
- One STM32W108xx MB951 USB dongle

Figure 1. MB950 remote application board

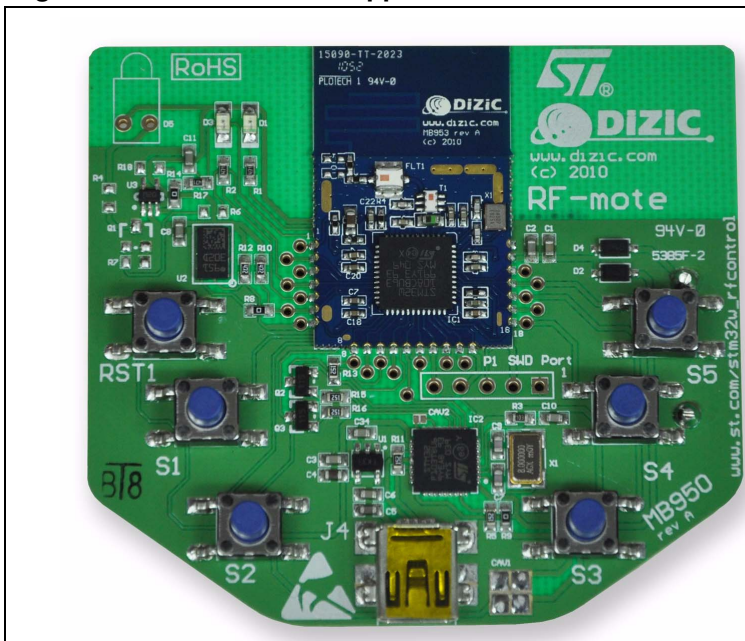
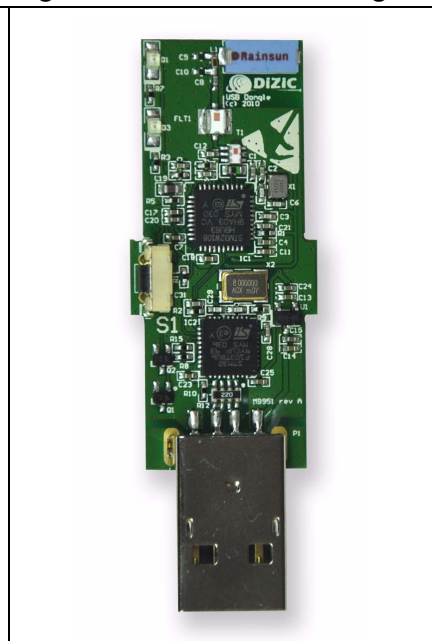

Figure 2. MB951 USB dongle



*Note:* For information concerning the STM32W108xx MB950 and MB951 boards, refer to the documentation included with all available software and the documentation tree installer file (see [Section 2.6: Software libraries and demonstration applications](#)).

### 2.2 MB950 hardware description

#### 2.2.1 MB950 resources

The following table lists the resources available in the MB950 board to develop applications, and their connections with STM32W108 pins.

**Table 1. MB950 resources**

			Rev. A
Type	Label	Part	STM32W108 pin
Button	RST1		nRST
Button	S1		PB3
Button	S2		PA7
Button	S3		PB7
Button	S4		PB0
Button	S5		PB6
Led	D1		PA5
Led	D3		PA0
Led	D5	Infrared led (not fitted)	PB4
Mems	U2	LIS302	PA1, PA2
Temperature Sensor	U3	STLM20	PA4

### 2.2.2 MB950 connectors

The following table lists the connectors available in the MB950 board and their functionalities.

**Table 2. MB950 connectors**

Type	Label	Function
Mini USB	J4	PC I/O
Debug Connector	P1	SWD debug

### 2.2.3 MB950 connectors: P1 pins

**Table 3. MB950 connectors: P1 pins**

Name	GPIO/ Function
1	GND
2	+VBRD
3	nRST
4	SWDIO/JTMS
5	SWCLK/JTCK

### 2.2.4 MB950 jumper configuration

None

## 2.2.5 MB950 PC interface chip

The following table lists the PC interface chip available in the MB950 board to allow I/O interface to the STM32W108.

**Table 4. MB950 PC interface chip**

Type	Part
PC I/O interface	STM32F103TBU6

## 2.2.6 MB950 battery holder

**Table 5. MB950 battery holder**

Type	Part
2x AAA battery holder	BT1

## 2.3 MB951 hardware description

### 2.3.1 MB951 resources

The following table lists the resources available in the MB951 board to develop applications and their connection with STM32W108 pins.

**Table 6. MB951 resources**

			Rev. A
Type	Label	Part	STM32W108 pin
Button	S1		A3
Led	D1		PA5
Led	D3		PA0

### 2.3.2 MB951 connectors

The following table lists the connectors available in the MB951 board and their functionalities.

**Figure 3. MB951 connectors**

Type	Label	Function
USB	P1	PC I/O

### 2.3.3 MB951 jumper configuration

None

### 2.3.4 MB951 PC interface chip

The following table lists the PC interface chip available in the MB951 board to allow I/O interface to the STM32W108.

**Table 7. MB951 PC interface chip**

Type	Part
PC I/O interface	STM32F103TBU6

### 2.3.5 MB951 battery holder

None

## 2.4 Software

The STM32W-RFCKIT RF control kit does not contain any CD-ROMs.

## 2.5 Documentation

The STM32W-RFCKIT RF control kit contains a welcome letter which briefly describes its components and targeted applications.

## 2.6 Software libraries and demonstration applications

The following installer files are available on the STM32W 32-bit RF microcontroller webpages:

- **ST Simple MAC- 1.0.3.0-STM32W108**: installer file which provides the STM32W108 Simple MAC software library and demonstration applications targeting point-to-point communication scenarios based on the IEEE 802.15.4 protocol.
- **ST ZigBee RF4CE-1.2.0.0-STM32W108**: installer file which provides the STM32W108 ZigBee RF4CE software library and demonstration applications for controlling an RF4CE-compliant TV using an RF4CE-compliant remote control.
- **EmberZNet-4.3.0.0-STM32W108**: installer file which provides the EmberZNet™ 4.3.0 GA software libraries and demonstration applications targeting the mesh network scenarios based on the ZigBee PRO protocol stack.

- Note:*
- 1 For a detailed description of software and documentation trees, refer to the related documentation (starting from the HTML index file, that comes with each installer file).
  - 2 Each installer file also provides a set of prebuilt binary images (applications and utilities).
  - 3 For the most recent installer file versions, visit the STM32W 32-bit RF microcontroller webpages at [www.st.com/stm32w\\_rfcontrol](http://www.st.com/stm32w_rfcontrol)

## 2.7 Kit setup

### 2.7.1 Powering on the boards

The MB950 application board can be powered as follows:

- Via batteries
- Via USB

To power on the MB951 USB dongle, simply plug it into a PC USB port.

### 2.7.2 Installing the ST Virtual COM port driver USB drive

To use the serial communication channel on the kit application boards, a Virtual COM port driver for STM32F103xx must be installed. This driver can be directly downloaded from the ST website at [http://www.st.com/internet/com/SOFTWARE\\_RESOURCES/SW\\_COMPONENT/SW\\_DRIVER/vcpdriver\\_v1.zip](http://www.st.com/internet/com/SOFTWARE_RESOURCES/SW_COMPONENT/SW_DRIVER/vcpdriver_v1.zip)

### 2.7.3 Setting up the application serial communication channel

To setup a serial communication channel for the kit application boards, follow these steps:

1. On the MB950 application board, connect a mini-USB cable between the board's mini-USB connector and a PC USB port.
2. Plug the MB951 USB dongle into a PC USB port.
3. Using the mouse, right-click on **My Computer**, select **Manage, Device Manager**, and open **Ports (COM & LPT)** to display the related USB COMx ports.
4. Open a Hyper Terminal on the corresponding USB virtual COMx ports with the following configuration:

Bit rate: 115200; Data bits: 8; Parity: None; Stop bits: 1; Flow control: None



## 3 Running the STM32W-RFCKIT RF control kit

In the STM32W-RFCKIT RF control kit, the Simple MAC talk application is preprogrammed on both kit boards.

The Simple MAC talk demonstration application is a simple application that demonstrates point-to-point IEEE 802.15.4 wireless communications using the STM32W108xx MCU.

It allows basic RF control of the USB dongle LEDs by pushing the application board's buttons. Further, it can be used as a wireless RS-232 cable replacement. For example, all data received on the serial port will be sent wirelessly to the other board and all the data received wirelessly will be sent to the serial port.

### 3.1 Installing the STM32W-RFCKIT RF control kit software tree

To install the specific kit software and documentation tree, download the related installer file from the STM32W 32-bit RF microcontroller webpages, then start the installation process on your destination folder.

#### 3.1.1 Building and download the Simple MAC talk demonstration application

The Simple MAC talk demonstration application runs on all STM32W-RFCKIT RF control kit boards.

##### Using the prebuilt talk binary image

To download and run the prebuilt talk binary image on the kit's board, use the `stm32w_flasher` utility with the prebuilt `talk.s37` binary file. For information on how to use the `stm32w_flasher` utility, refer to [Section 4.1: `stm32w\_flasher` utility](#).

##### Using the talk IAR project

An IAR workspace is also provided for building the Simple MAC talk demonstration application.

Follow these steps to build the talk demonstration application image `talk.s37`.

1. Open the IAR toolset.
2. From the **File, Open, Workspace** menu, open the **talk.eww** IAR project.
3. From the **Project** menu, select **Rebuild All**. A binary file `talk.s37` is built in the specific demonstration application directory under the selected installation path.

*Note:* For the talk application, two workspaces are provided:

1. *STM32W108* used to build a binary image with no IAP bootloader support.
2. *STM32W108-btl* used to build a binary image supporting the IAP bootloader (file `iap_bootloader.s37` in the prebuilt folder).

### 3.1.2 Basic RF communication using the talk demonstration application

Once the talk application has been loaded on the kit's board, different RF communication scenarios can be targeted as described in the table below.

**Table 8. Supported talk RF control scenarios through application board buttons**

Application board	USB dongle
Press button S1	LED D1 toggles
Press button S2	LED D3 toggles
Press button S3	LED D1, D3 both toggle
Press button S4	LED D1 blinks for few seconds
Press button S5	LED D3 blinks for few seconds

- Note:*
- 1 When pressing a button on the application board, LED D1 is turned on, indicating a packet is going to be sent.
  - 2 When pressing a button on the application board, if something is wrong with the current RF communication (packet transmission failed or no acknowledgment received from the USB dongle), the application board LEDs D1 and D3 start blinking for few seconds.

For setting a “chat communication”, it is requested to setup a serial communication channel on both kit's boards by following the steps described in [Section 2.7.3: Setting up the application serial communication channel](#).

Once the serial communication channels of the kit's boards are correctly configured, the two talk demonstration applications can communicate by typing the “chat text” on the corresponding HyperTerminal.

The above example application shows how an RS-232 cable connection between two devices can be replaced with a wireless system using STM32W108xx microcontrollers.

## 4 STM32W-RFCKIT utilities and software tools

### 4.1 stm32w\_flasher utility

The stm32w\_flasher utility allows you to download a binary file into the STM32W-RFCKIT RF control kit's boards. This utility comes with the Simple MAC software installer file.

To download a binary image, follow these steps:

1. Connect the kit board to a PC USB port.
2. Using the mouse, right-click on **My Computer**, select **Manage, Device Manager**, and open **Ports (COM & LPT)** to display the related USB COMx port.
3. Open a DOS Window on your PC and go to the utilities folder which is created after the installation process.
4. Type the following command:

```
stm32w_flasher -p <COMx> -r -f <file_name.bin/.s37>
```

where COMx is the virtual COM related to the connected application board, and *file\_name.bin/.s37* is the application image to be downloaded.

## 5 List of acronyms

**Table 9. List of acronyms**

<b>Term</b>	<b>Meaning</b>
API	Application programming interfaces
CERC	Consumer electronic remote control
GA	General availability
HAL	Hardware abstraction layer
IDE	Integrated development tool
MAC	Media access control
RC	Remote control
RF	Radio frequency communication
USB	Universal serial bus

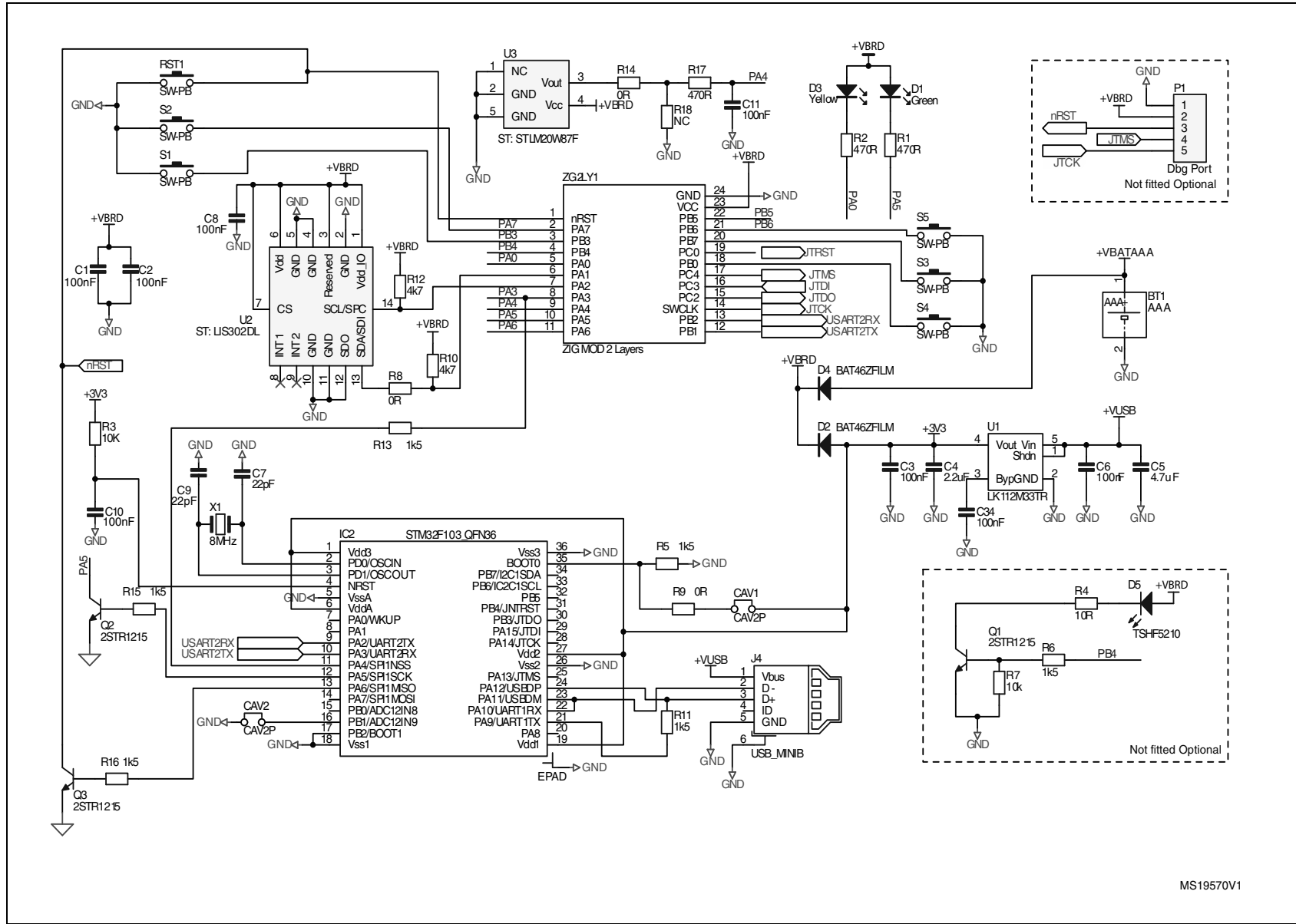



Figure 5. MB950 Rev.A

Doc ID 18433 Rev 2

14/17



MS19570V1



Figure 6. MB951 Rev.A

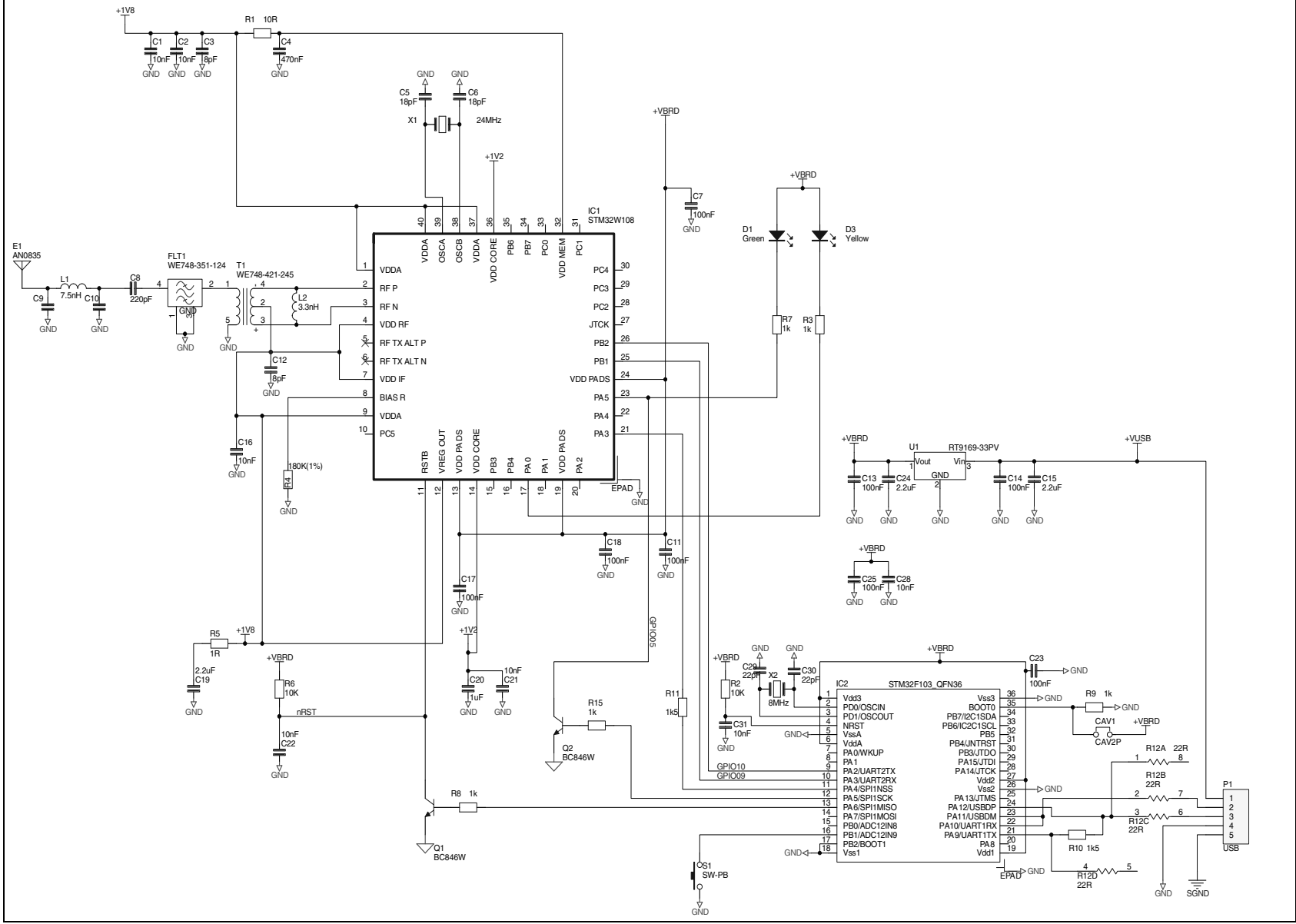

## 6 Revision history

Table 10. Document revision history

Date	Revision	Changes
14-Feb-2011	1	Initial release
21-Jun-2011	2	Added <a href="#">Section 2.2: MB950 hardware description</a> Added <a href="#">Section 2.3: MB951 hardware description</a> Added <a href="#">Section Appendix A: Available board schematics</a>



**Please Read Carefully:**

Information in this document is provided solely in connection with ST products. STMicroelectronics NV and its subsidiaries ("ST") reserve the right to make changes, corrections, modifications or improvements, to this document, and the products and services described herein at any time, without notice.

All ST products are sold pursuant to ST's terms and conditions of sale.

Purchasers are solely responsible for the choice, selection and use of the ST products and services described herein, and ST assumes no liability whatsoever relating to the choice, selection or use of the ST products and services described herein.

No license, express or implied, by estoppel or otherwise, to any intellectual property rights is granted under this document. If any part of this document refers to any third party products or services it shall not be deemed a license grant by ST for the use of such third party products or services, or any intellectual property contained therein or considered as a warranty covering the use in any manner whatsoever of such third party products or services or any intellectual property contained therein.

**UNLESS OTHERWISE SET FORTH IN ST'S TERMS AND CONDITIONS OF SALE ST DISCLAIMS ANY EXPRESS OR IMPLIED WARRANTY WITH RESPECT TO THE USE AND/OR SALE OF ST PRODUCTS INCLUDING WITHOUT LIMITATION IMPLIED WARRANTIES OF MERCHANTABILITY, FITNESS FOR A PARTICULAR PURPOSE (AND THEIR EQUIVALENTS UNDER THE LAWS OF ANY JURISDICTION), OR INFRINGEMENT OF ANY PATENT, COPYRIGHT OR OTHER INTELLECTUAL PROPERTY RIGHT.**

**UNLESS EXPRESSLY APPROVED IN WRITING BY AN AUTHORIZED ST REPRESENTATIVE, ST PRODUCTS ARE NOT RECOMMENDED, AUTHORIZED OR WARRANTED FOR USE IN MILITARY, AIR CRAFT, SPACE, LIFE SAVING, OR LIFE SUSTAINING APPLICATIONS, NOR IN PRODUCTS OR SYSTEMS WHERE FAILURE OR MALFUNCTION MAY RESULT IN PERSONAL INJURY, DEATH, OR SEVERE PROPERTY OR ENVIRONMENTAL DAMAGE. ST PRODUCTS WHICH ARE NOT SPECIFIED AS "AUTOMOTIVE GRADE" MAY ONLY BE USED IN AUTOMOTIVE APPLICATIONS AT USER'S OWN RISK.**

Resale of ST products with provisions different from the statements and/or technical features set forth in this document shall immediately void any warranty granted by ST for the ST product or service described herein and shall not create or extend in any manner whatsoever, any liability of ST.

ST and the ST logo are trademarks or registered trademarks of ST in various countries.

Information in this document supersedes and replaces all information previously supplied.

The ST logo is a registered trademark of STMicroelectronics. All other names are the property of their respective owners.

© 2011 STMicroelectronics - All rights reserved

STMicroelectronics group of companies

Australia - Belgium - Brazil - Canada - China - Czech Republic - Finland - France - Germany - Hong Kong - India - Israel - Italy - Japan - Malaysia - Malta - Morocco - Philippines - Singapore - Spain - Sweden - Switzerland - United Kingdom - United States of America

[www.st.com](http://www.st.com)

