

## Lithium Manganese Battery Li-MnO<sub>2</sub>

Primary characteristics		
Parameter	Value	Unit
Nominal voltage	3.0	V
Rated capacity	600	mAh

### Scope

The purpose of this product specification is to provide technical information for the Lithium Manganese Battery Li-MnO<sub>2</sub> battery .

The test shall be conducted in strict accordance with the method specified in this specification.

If you have any objection to the test items or test methods, please contact Akyga Battery.

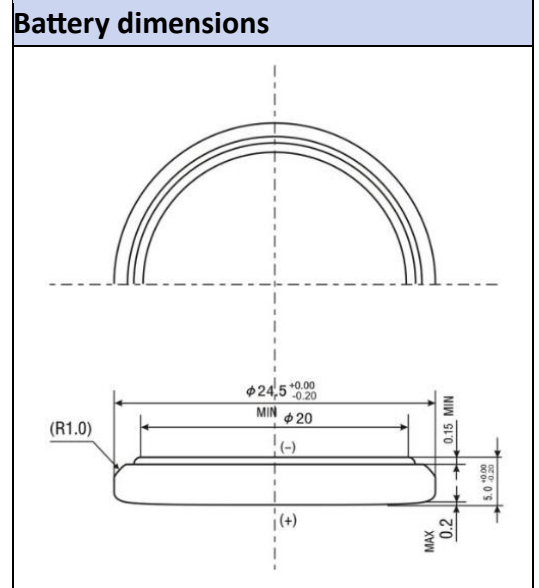

### Specification table

Parameter	Value	Unit
Battery model	CR2016	
Nominal voltage	3.0	V
Nominal capacity	600	mAh
Operating temperature	-20/+70	°C
Average weight	6.2	g
<b>Notes:</b> Continually discharge at 7.5kΩ resistance to cut-off voltage 2.0V		
<b>Electrical Performance:</b> Testing Conditions: Temperature: 23°C ±3°C		
<b>Identification</b> The contents printed on the label: Model: CR2450 Registered Trademark: Akyga Battery Nominal Voltage: 3.0V Battery Poloidal: “+” and “-“ Warning words: Install and use correctly. Do not recharge, disassemble, heat and shot-circuit		

**Discharge characteristic**

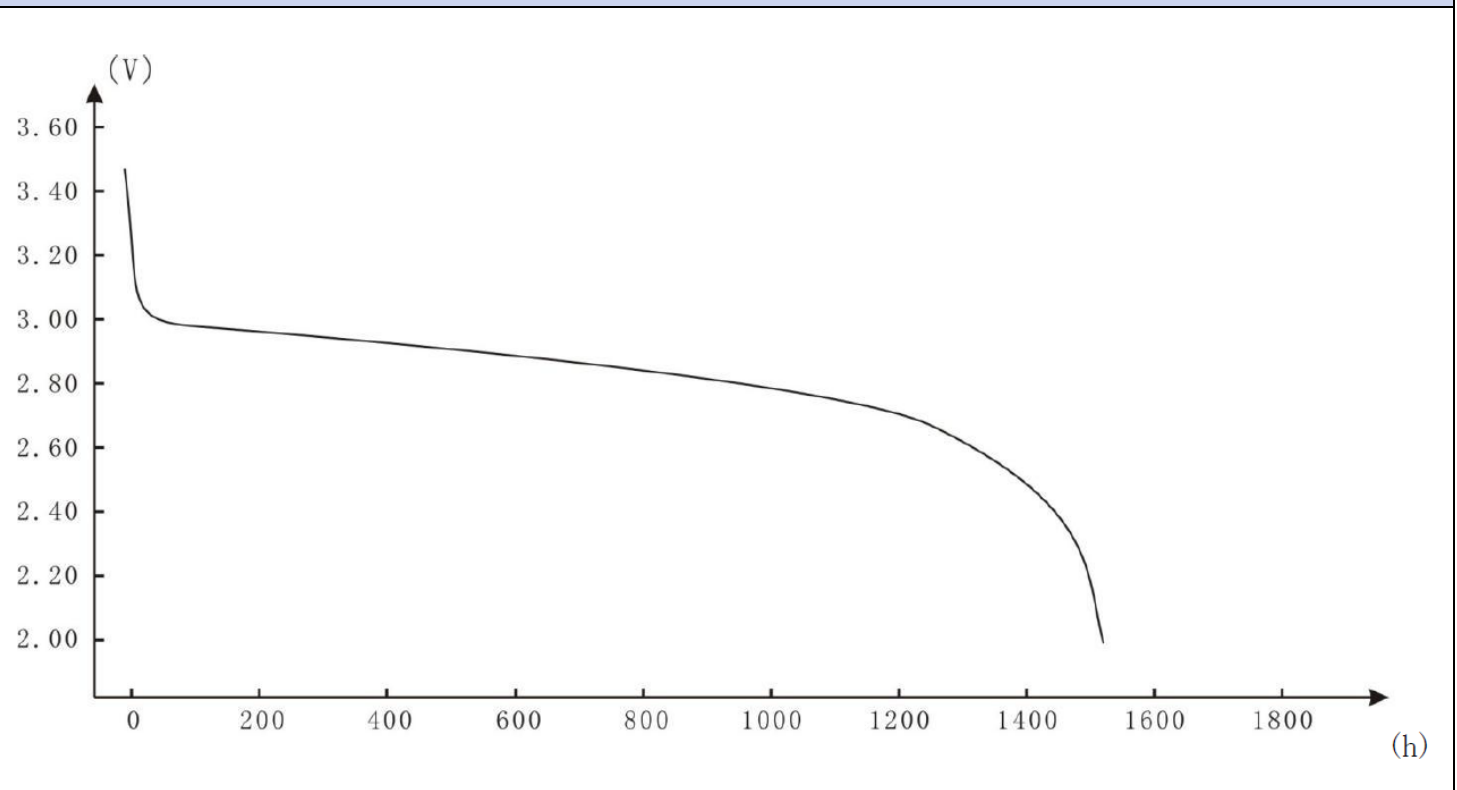

**Important notes**

- Do not short circuited, recharge, heat, disassemble nor dispose in fire
- Do not force-discharge.
- Do not make the anode and the cathode reversed
- Do not solder directly
- Keep battery out of children’s reach
- Do not store or use in the environment of over 60°C

Akyga Battery reserves the right to make changes without notice to any product specification herein, to make corrections, modifications, enhancements or other changes. Akyga Battery or anyone on its behalf assumes no responsibility or liability for any errors or inaccuracies. Data sheet specifications and its information contained are intended to provide a product description only. "Typical" parameters which may be included on Akyga Battery data sheets and/ or specifications can and do vary in different applications and actual performance may vary over time. Akyga Battery does not assume any liability arising out of the application or use of any product or circuit. Akyga Battery products are not designed, intended or authorized for use in medical, life-saving implant or other applications intended for life-sustaining or other related applications where a failure or malfunction of component or circuitry may directly or indirectly cause injury or threaten a life without expressed written approval of Akyga Battery. Customers using or selling Akyga Battery components for use in such applications do so at their own risk and shall agree to fully indemnify Akyga Battery and its subsidiaries harmless against all claims, damages and expenditures.