

## ELECTRICAL CHARACTERISTIC

Nominal Capacity	<b>1.5Ah</b>
	(At 1.0Ma, +25°C 2.0V cut off)
	The capacity restored by the cell varies to current drain, temperature and cut-off)
Rated Voltage	<b>3.0V</b>
Max. Recommended Continuous Current	<b>1500mA</b>
Max. Pulse Current Capability	<b>3000mA</b>
Storage (recommended)	<b>Max. 30°C</b>
Operating Temp. Range	<b>-40°C to +85°C</b>
	(Operating closely to limit temp. may lead to a reduced capacity, low voltage plateau reading)
Typical Weight	<b>20g</b>
Storage life 10 years	



## Key features

- High and stable operating voltage
- Low self-discharge rate  
(less than 1% after 1-year storage at 25°C)
- Stainless steel container
- Semi-Hermetic sealing
- Non-flammable electrolyte
- Spiral type
- CE, SGS recognized

ISO9001 approved

## Main application

- Utility Metering
- Memory Back-up
- Alarms & Security Devices
- Automotive electronics
- Tollgate systems
- Military electronics
- Automatic meter reading
- Professional electronics

## WARNINGS!

1. Fire, explosion and severe burn hazard;
2. Do not recharge, crush, disassemble, heat above 100°C;
3. Do not solder directly to the cell.

## LOADING VOLT. AT ROOM TEMP.

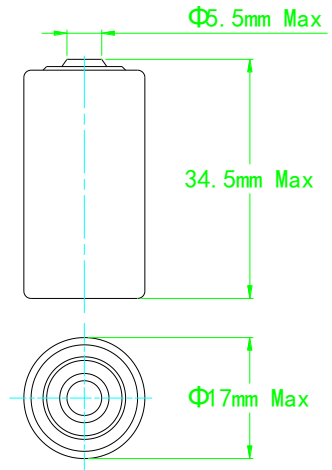
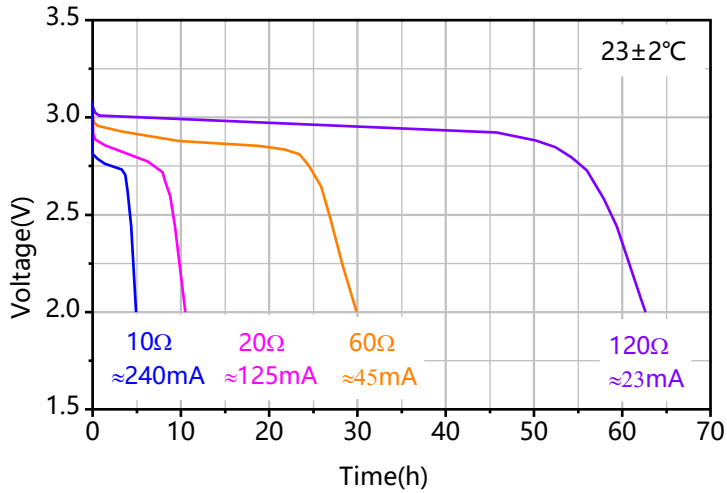

## TEMPERATURE

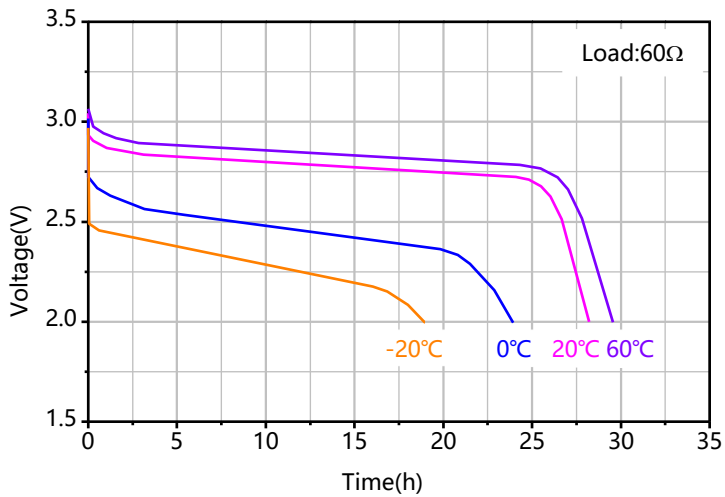

## PULSE CURRENT

