



ED-IPC2100 Series

High Reliability Industrial Computer Based On Raspberry Pi CM4

User Manual

EDA Technology Co., LTD

July 2023

Contact Us

Thank you very much for purchasing and using our products, and we will serve you wholeheartedly.

As one of the global design partners of Raspberry Pi, we are committed to providing hardware solutions for IOT, industrial control, automation, green energy and artificial intelligence based on Raspberry Pi technology platform.

You can contact us in the following ways:

EDA Technology Co.,LTD

Address:Room 301, Building 24, No.1661 Jialuo Road, Jiading District,
Shanghai

Mail: sales@edatec.cn

Phone: +86-18217351262

Website: <https://www.edatec.cn>

Technical Support:

Mail: support@edatec.cn

Phone: +86-18627838895

Wechat: zzw_1998-

Copyright Statement

ED-IPC2100 series and its related intellectual property rights are owned by EDA Technology Co.,LTD.

EDA Technology Co.,LTD owns the copyright of this document and reserves all rights. Without the written permission of EDA Technology Co.,LTD, no part of this document may be modified, distributed or copied in any way or form.

Disclaimer

EDA Technology Co.,LTD does not guarantee that the information in this manual is up to date, correct, complete or of high quality. EDA Technology Co.,LTD also does not guarantee the further use of this information. If the material or non-material related losses are caused by using or not using the information in this manual, or by using incorrect or incomplete information, as long as it is not proved that it is the intention or negligence of EDA Technology Co.,LTD, the liability claim for EDA Technology Co.,LTD can be exempted. EDA Technology Co.,LTD expressly reserves the right to modify or supplement the contents or part of this manual without special notice.

Foreword

Related Manuals

All kinds of product documents contained in the product are shown in the following table, and users can choose to view the corresponding documents according to their needs.

Documents	Instruction
ED-IPC2100 Series Datasheet	This document introduces the product features, software and hardware specifications, dimensions and ordering code of ED-IPC2100 series to help users understand the overall system parameters of the products.
ED-IPC2100 Series User Manual	This document introduces the appearance, installation, startup and configuration of ED-IPC2100 series to help users use the product better.
ED-IPC2100 Series Application Guide	This document introduces the OS download, eMMC flashing and partial configuration of ED-IPC2100 series to help users use the product better.

Users can visit the following website for more information:

<https://www.edatec.cn>

Reader Scope

This manual is applicable to the following readers:



- ◆ Mechanical Engineer
- ◆ Electrical Engineer
- ◆ Software Engineer
- ◆ System Engineer

Related Agreement

Terminology Convention

Terminology	Meaning
CM4	Raspberry Pi Compute Module 4

Symbolic Convention

Symbolic	Instruction
	Prompt symbols, indicating important features or operations.
	Notice symbols, which may cause personal injury, system damage, or signal interruption/loss.
	May cause great harm to people.

Safety Instructions

- ◆ This product should be used in an environment that meets the requirements of design specifications, otherwise it may cause failure, and functional abnormality or component damage caused by non-compliance with relevant regulations are not within the product quality assurance scope.
- ◆ Our company will not bear any legal responsibility for personal safety accidents and property losses caused by illegal operation of products.
- ◆ Please do not modify the equipment without permission, which may cause equipment failure.
- ◆ When installing equipment, it is necessary to fix the equipment to prevent it from falling.
- ◆ If the equipment is equipped with an antenna, please keep a distance of at least 20cm from the equipment during use.
- ◆ Do not use liquid cleaning equipment, and keep away from liquids and flammable materials.
- ◆ This product is only supported for indoor use.

Content

Foreword	i
Related Manuals	i
Reader Scope	i
Related Agreement	ii
Terminology Convention.....	ii
Symbolic Convention	ii
Safety Instructions.....	iii
1 Product Description.....	1-1
1.1 Overview.....	1-2
1.2 Packing List	1-3
1.3 Appearance	1-4
1.3.1 Front Panel	1-4
1.3.2 Rear Panel.....	1-5
1.3.3 Side Panel	1-5
1.4 Button	1-7
1.5 Indicator	1-8
1.6 Interface.....	1-9
1.6.1 Card Slot.....	1-9
1.6.2 Power Supply Interface.....	1-9
1.6.3 Audio Interface (optional).....	1-10
1.6.4 RS485/RS232 Interface	1-10
1.6.5 1000M Ethernet Interface	1-13
1.6.6 100M Ethernet Interface	1-13
1.6.7 HDMI Interface.....	1-14
1.6.8 USB 2.0 Interface	1-14
1.6.9 Micro USB Interface.....	1-14
1.6.10 Antenna Interface	1-14
1.6.11 Motherboard Interface	1-14
2 Installing Components.....	2-1
2.1 Installing Internal Components (optional).....	2-2
2.1.1 Open Device Case.....	2-2
2.1.2 Install RTC battery	2-3
2.1.3 Close Device Case	2-4
2.2 Installing Other Components	2-6
2.2.1 Install Antenna (optional)	2-6
2.2.2 Install Micro SD Card.....	2-6
2.2.3 Install Nano SIM Card (optional).....	2-7
3 Installing Device	3-1
3.1 DIN-Rail Installation	3-2
4 Booting The Device.....	4-1
4.1 Connecting Cables.....	4-2
4.2 Booting The System For The First Time.....	4-3

4.2.1	Raspberry Pi OS (Desktop)	4-3
4.2.2	Raspberry Pi OS (Lite).....	4-3
5	Configuring System.....	5-1
5.1	Finding Device IP.....	5-2
5.1.1	Query IP by Using ifconfig Command.....	5-2
5.1.2	Login Router to Query IP	5-2
5.1.3	Scan For Using NMAP Tool	5-3
5.2	Remote Login	5-5
5.2.1	Connect To The Device Via SSH	5-5
5.2.2	Connect To The Device Desktop Through VNC.....	5-7
5.3	Configuring Storage Devices	5-10
5.3.1	Mounting a Storage Device	5-10
5.3.2	Unmount The Storage Device.....	5-12
5.3.3	Set The Storage Device To Mount Automatically	5-12
5.4	Configuring Ethernet IP.....	5-14
5.4.1	Configure IP by Using The NetworkManager Tool	5-14
5.4.2	Configure IP by Using The dhcpcd Tool.....	5-17
5.5	Configuring WiFi (Optional).....	5-19
5.5.1	Enable WiFi Function.....	5-19
5.5.2	Use The NetworkManager Tool To Configure WiFi Connections	5-21
5.5.3	Configure WiFi Connection By Using dhcpcd Tool.....	5-23
5.6	Configuring Bluetooth (optional)	5-25
5.6.1	Basic Configuration Command	5-25
5.6.2	Configuration Example	5-25
5.7	Configuring 4G (Optional).....	5-27
5.7.1	Use The NetworkManager Tool To Configure The Network	5-27
5.7.2	Configure The Network By Using The dhcpcd Tool.....	5-28
5.7.3	Configure 4G Module Reset	5-29
5.8	Configuring Buzzer	5-31
5.9	Configuring RTC	5-32
5.10	Configuring Serial Port.....	5-33
5.10.1	Install picocom tool	5-33
5.10.2	Configure RS232	5-33
5.10.3	Configure RS485	5-33
5.11	Configuring Audio (Optional).....	5-35
5.11.1	Adjust The Volume.....	5-35
5.11.2	Configure Record.....	5-37
5.12	Configuring USER Indicator.....	5-39

1 Product Description

This chapter introduces the product overview, packing list, appearance, button, indicators and interfaces.

- ✓ Overview
- ✓ Packing List
- ✓ Appearance
- ✓ Button
- ✓ Indicator
- ✓ Interface

1.1 Overview

ED-IPC2100 series is a highly reliable industrial computer based on Raspberry Pi CM4. According to different application scenarios and user needs, different specifications of RAM and eMMC computer systems can be selected.

- ◆ RAM can choose 1GB、2GB、4GB and 8GB
- ◆ eMMC can choose 8GB、16GB and 32GB

ED-IPC2100 series provides common interfaces such as HDMI, USB, Ethernet, RS232 and RS485, and supports access to the network through Wi-Fi, Ethernet and 4G. The integration of super capacitor (backup power supply, which is optional), RTC, Watch Dog, EEPROM and encryption chip provides the ease of use and reliability of the product, which is mainly used in industrial control and IOT.



1.2 Packing List

- ◆ 1x ED-IPC2100 Unit (with DIN-rail bracket)
- ◆ **[option WiFi/BT version]** 1x 2.4GHz/5GHz WiFi/BT Antenna
- ◆ **[option 4G version]** 1x 4G/LTE Antenna

1.3 Appearance

Introducing the functions and definitions of interfaces on each panel.

1.3.1 Front Panel

Introducing the front panel interface types and definitions.

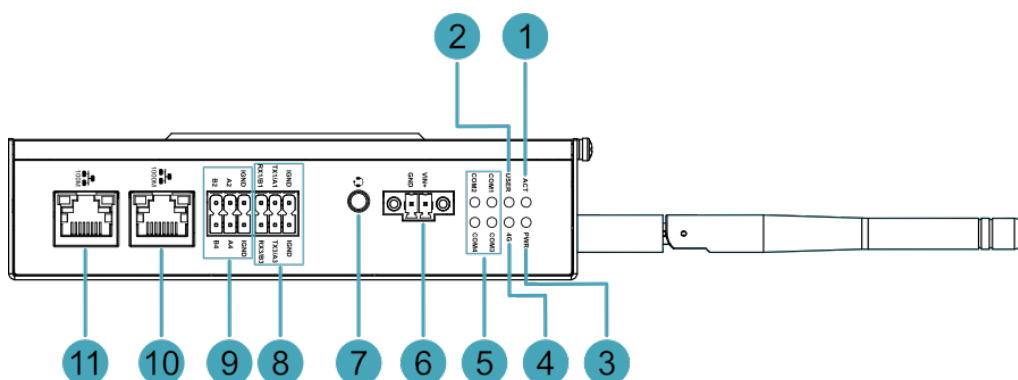

NO.	Function Definition
1	1 x green system status indicator, which is used to check the working status of device.
2	1 x green user indicator, user can customize a status according to actual application.
3	1 x red power indicator, which is used to check the status of device power-on and power-off.
4	1 x green 4G indicator, which is used to check the status of 4G signal.
5	4 x green UART indicators, which is used to check the communication status of UART port.
6	1 x DC input, 2-Pin 3.5mm spacing phoenix terminals with screw holes. It supports 9V~36V input, the signal is defined as VIN+/GND.
7	1 x Audio input/Stereo output, 3.5mm audio jack connector. It can be used as MIC IN and LINE OUT. <ul style="list-style-type: none"> When a headphone is connected, the audio output is switched to the headphone. When a headphone is not connected, the audio output is switched to the speaker. Note: Only ED-IPC2120 contains this interface.
8	2 x RS232/RS485 ports, 6-Pin 3.5mm spacing phoenix terminals, which is used to connect third-party control equipment. Different combinations of RS232 and RS485 can be selected according to actual needs, and there are three combinations: <ul style="list-style-type: none"> ED-IPC2110: 2 x RS232 ED-IPC2100: 2 x RS232 ED-IPC2130: 1 x RS232 and 1 x RS485

NO.	Function Definition
	● ED-IPC2140: 2 x RS485
9	2 x RS485 ports, 6-Pin 3.5mm spacing phoenix terminal, which is used to connect the third-party control equipment.
10	1 x 10/100/1000M adaptive ethernet port, RJ45 connector, with led indicator. It can be used to access the network. PoE can be supported through expansion module.
11	1 x 10/100M adaptive ethernet port, RJ45 connector, with led indicator. It can be used to access the network.

1.3.2 Rear Panel

Introducing the types and definitions of the rear panel interface.

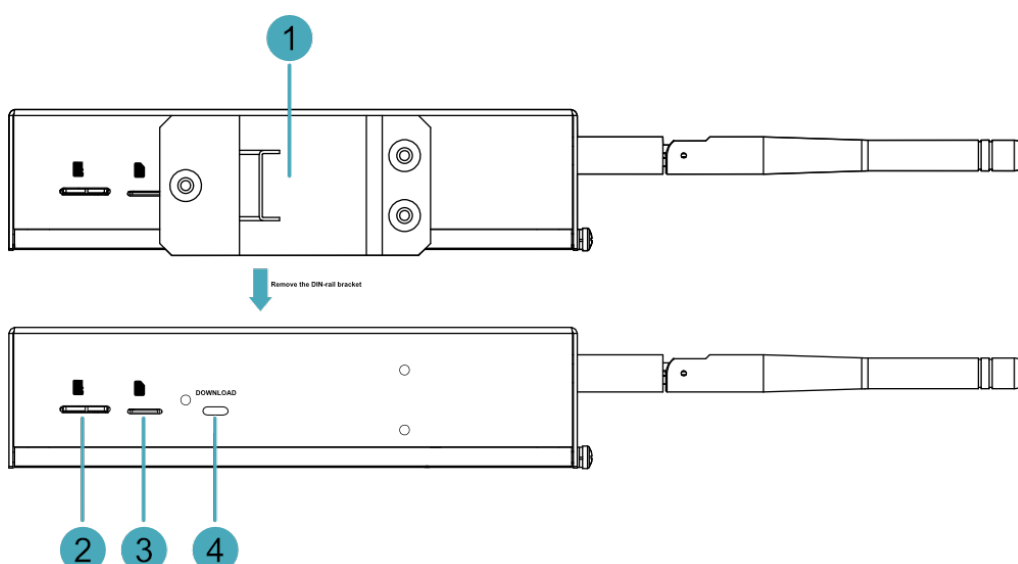

NO.	Function Definition
1	1 x DIN-rail bracket, install ED-IPC2100 Unit on the DIN-rail through the bracket.
2	1 x Micro-SD card slot, it supports the installation of SD card for storing user data.
3	1 x Nano SIM slot, uses to install a SIM card for acquiring 4G signals.
4	1 x Micro USB port, it supports to flash eMMC for the system.

1.3.3 Side Panel

Introducing the types and definitions of side panel interfaces.

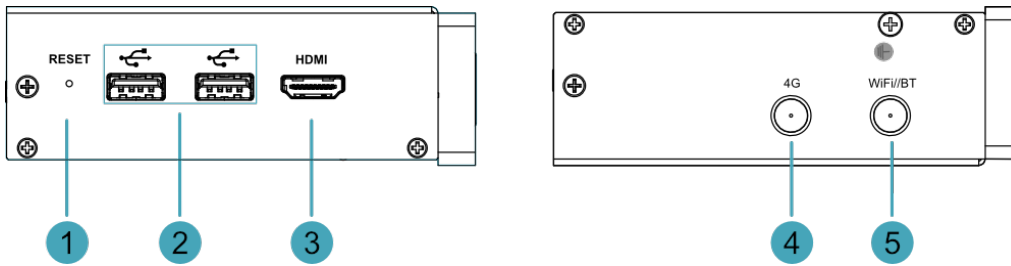

NO.	Function Definition
1	1 x Reset button, hidden button, press the button to restart the device.
2	2 x USB 2.0 ports, type A connector, each channel supports up to 480Mbps.
3	1 x HDMI port, type A connector, which compatibles with HDMI2.1 standard and supports 4K 60Hz. It supports to connect a displayer.
4	1 x 4G antenna port, SMA connector, which can connect to 4G antenna.
5	1 x WiFi/BT antenna port, SMA connector, which can connect to WiFi/BT antenna.

1.4 Button

ED-IPC2100 series device includes a RESET button, which is a hidden button, and the silkscreen on the case is "RESET". The RESET button is connected with the Global_EN pin of CM4 chip.

- ◆ When the Global_EN pin is high level, it means that CM4 has been started;
- ◆ When the Global_EN pin is low level, the CM4 will be reset.

Pressing the RESET button will pull the Global_EN pin low and reset the device.

1.5 Indicator

Introducing the various statuses and meanings of indicators contained in ED-IPC2100 series device.

Indicator	Status	Description
PWR	On	The device has been powered on.
	Blink	Power supply of the device is abnormal, please stop the power supply immediately.
	Off	The device is not powered on.
ACT	Blink	The system started successfully and is reading and writing data.
	Off	The device is not powered on or does not read and write data.
USER	On	User can customize a status according to actual application.
	Off	The device is not powered on or not defined by the user, and the default status is off.
4G	On	The dial-up is successful and the connection is normal.
	Off	4G signal is not connected or the device is not powered on.
Yellow indicator of Ethernet port	On	The data transmission is abnormal.
	Blink	Data is being transmitted over the Ethernet port.
	Off	The Ethernet connection is not set up.
Green indicator of Ethernet port	On	The Ethernet connection is in the normal state.
	Blink	The Ethernet connection is abnormal.
	Off	The Ethernet connection is not set up.
COM1~COM4	On/Blink	Data is being transmitted.
	Off	The device is not powered on or there is no data transmission.

1.6 Interface

Introducing the definition and function of each interface in the product.

1.6.1 Card Slot

ED-IPC2100 series device includes an SD card slot and a Nano SIM card slot.

1.6.1.1 SD Card Slot

The silkscreen on the case of Micro SD card slot is "", which is used to install SD card for storing user data.

1.6.1.2 SIM Card Slot

The silkscreen on the case of Nano SIM card slot is "", which is used to install SIM card for obtaining 4G signals.

The size differences between standard SIM, Micro SIM and Nano SIM cards are as follows:

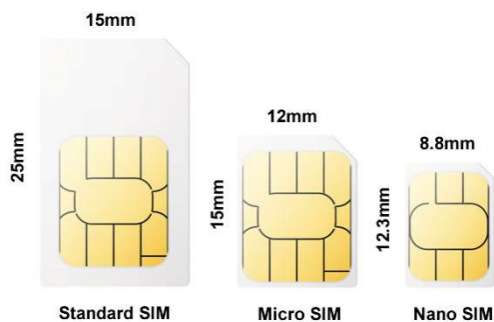

1.6.2 Power Supply Interface

The ED-IPC2100 series device includes one power input, 2-Pin 3.5mm spacing phoenix terminals with screw holes. The silkscreen of port is "VIN+/GND", and the pins are defined as follows.

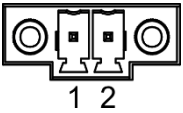
	Pin ID	Pin Name
	1	GND
	2	9V~36V

1.6.3 Audio Interface (optional)

ED-IPC2100 series device includes one audio input, the connector is a 3.5mm three-stage headphone jack. The silkscreen of port is "🎧", which supports OMTP stereo headphone output and mono microphone recording.

- ◆ When the headphone is connected, the audio output is switched to the headphone.
- ◆ When the headphone is not connected, the audio output is switched to the speaker.

1.6.4 RS485/RS232 Interface

ED-IPC2100 series equipment includes 2~4 RS485 ports and 0~2 RS232 ports, 6-Pin 3.5mm spacing phoenix terminals. Different product models correspond to different numbers of RS485 and RS232 ports:

- ◆ ED-IPC2110: 2 x RS485、2 x RS232
- ◆ ED-IPC2120: 2 x RS485、2 x RS232
- ◆ ED-IPC2130: 3 x RS485、1 x RS232
- ◆ ED-IPC2140: 4 x RS485 (not include RS232 port)

The silkscreen of single RS485 is "IGND/A/B" and the silkscreen of single RS232 is "IGND/TX/RX".

Pin Definition

Terminal pins are defined as follows:

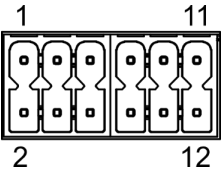
	Pin ID	Pin Name
	1	RS485-2_B
	2	RS485-4_B
	3	RS485-2_A
	4	RS485-4_A
	5	GND
	6	GND
	7	RS232-1_RX or RS485-1_B
	8	RS232-3_RX or RS485-3_B
	9	RS232-1_TX or RS485-1_A
	10	RS232-3_TX or RS485-3_A
	11	GND
	12	GND

The pin names of CM4 corresponding to RS485/RS232 interface are as follows:

Signal	CM4 GPIO Name	CM4 Pin Out
RS485-2_B	GPIO13	UART5_RXD
RS485-4_B	GPIO9	UART4_RXD
RS485-2_A	GPIO12	UART5_TXD
RS485-4_A	GPIO8	UART4_TXD
RS232-1_RX or RS485-1_B	GPIO5	UART3_RXD
RS232-3_RX or RS485-3_B	GPIO1	UART2_RXD
RS232-1_TX or RS485-1_A	GPIO4	UART3_TXD
RS232-3_TX or RS485-3_A	GPIO0	UART2_TXD

Connecting Cables

Schematic diagram of RS485 wires is as follows:

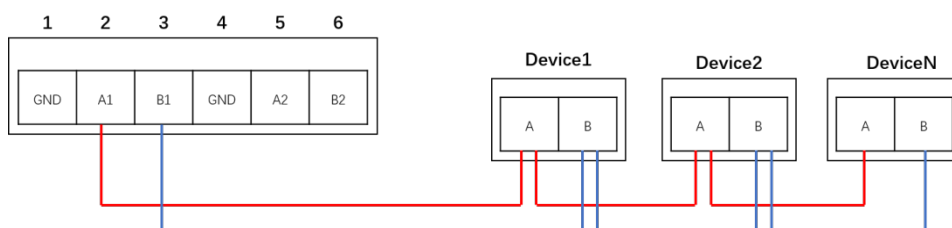

Schematic diagram of RS232 wires is as follows:

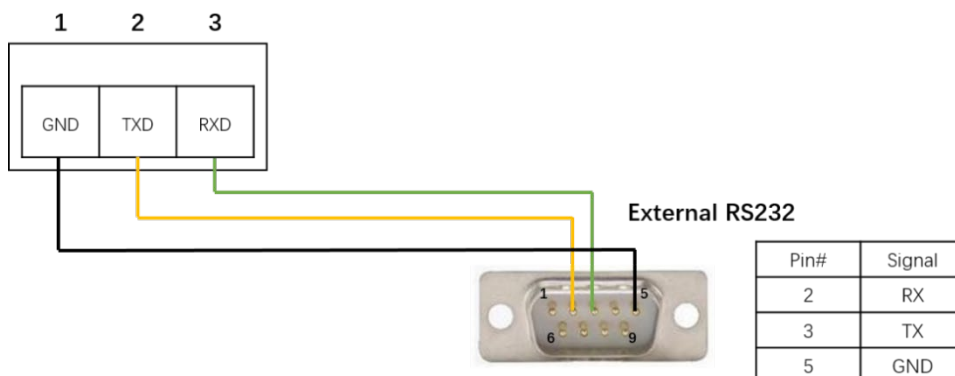

RS485 terminal resistance configuration

If high-frequency signals need to be transmitted by RS485 (baud rate higher than 115200), a terminal resistance of 120Ω needs to be added at the end of the transmission line.

- If the external RS485 device contains a terminal resistance of 120Ω, there is no need to set it.
- If the external RS485 device does not contain the terminal resistance of 120Ω, it is necessary to connect the terminal resistance of 120Ω on ED-IPC2100, as follows:
 1. Open the device case, see [2.1.1 Open Device Case](#) for detailed operation.
 2. Confirm the positions of 120Ω terminal resistors, such as J19, J21, J24 and J22 in PCBA as shown below.

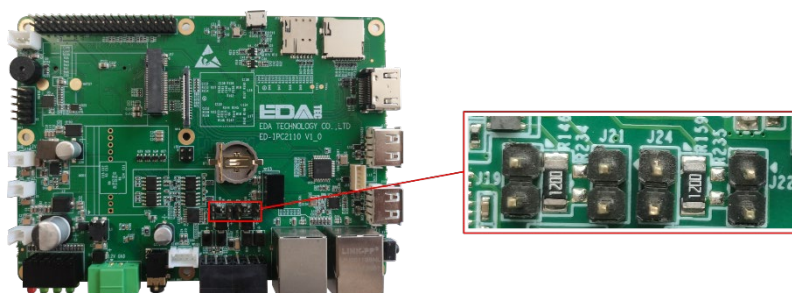

The corresponding relationship between 120Ω terminal resistance and serial port is as follows:

Location in PCBA	Corresponding COM port	The specific location of the corresponding COM
J19	COM3	
J21	COM1	
J24	COM4	
J22	COM2	

3. According to the serial port used, connect the 120Ω terminal resistor at the corresponding position in PCBA through the jumper cap.
4. Close the device case. See [2.1.3 Close Device Case](#) for detailed operation.

1.6.5 1000M Ethernet Interface

ED-IPC2100 series device includes one adaptive 10/100/1000M Ethernet port, and the silkscreen is . The connector is RJ45, which can support PoE with the expansion module. When accessing to network, it is recommended to use the network cable of Cat6 and above. The pins corresponding to the terminal are defined as follows:

	Pin ID	Pin Name
	1	TX4-
	2	TX4+
	3	TX3-
	4	TX3+
	5	TX2-
	6	TX2+
	7	TX1-
8	TX1+	

1.6.6 100M Ethernet Interface

ED-IPC2100 series device includes an adaptive 10/100M Ethernet port, and the silkscreen is . The connector is RJ45, and it is recommended to use the network cable with Cat6 and above when accessing to network. The pins corresponding to the terminal are defined as follows:

Pin ID	Pin Name
1	-
2	-
3	Rx-
4	-
5	-
6	Rx+
7	Rx--
8	Rx+

1.6.7 HDMI Interface

ED-IPC2100 series device includes one HDMI port, the silkscreen is "**HDMI**". The connector is type A HDMI, which can connect to an HDMI display and supports up to 4Kp60.

1.6.8 USB 2.0 Interface

ED-IPC2100 series device includes 2 USB2.0 ports, the silkscreen is "USB". The connector is type A USB, which can connect to standard USB 2.0 peripherals and supports up to 480Mbps.

1.6.9 Micro USB Interface

ED-IPC2100 series device includes one Micro USB interface, the silkscreen is "DOWNLOAD" and it can be connected to a PC to flash eMMC of the device.

1.6.10 Antenna Interface

The ED-IPC2100 series device includes 2 SMA antenna ports, the silkscreens are "4G" and "WiFi/BT" and they can be connected to the 4G antenna and WiFi/BT antenna.

1.6.11 Motherboard Interface

Introducing the interfaces reserved in the ED-IPC2100 series device, which can be obtained only after the device case is opened, and can be expanded according to actual needs.

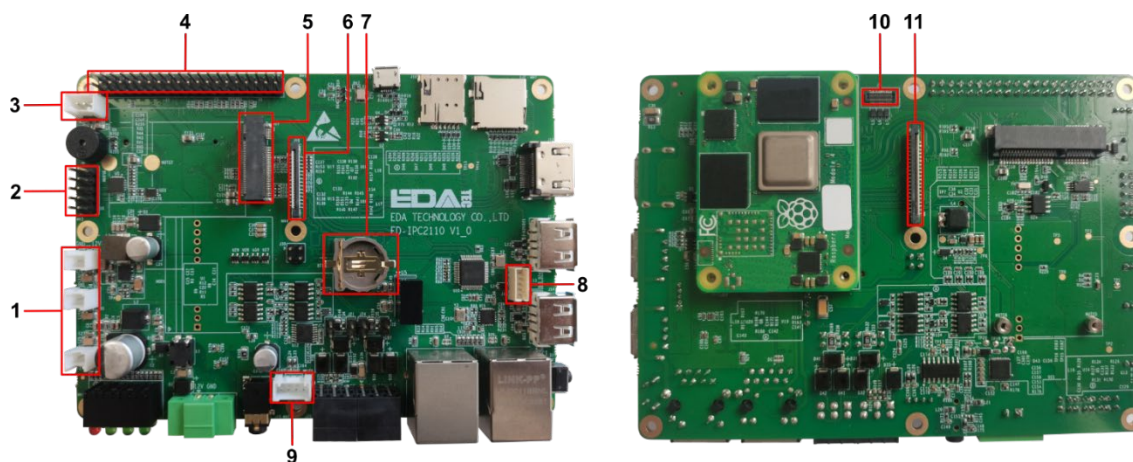

NO.	Function
1	5V 1A Output
2	10-Pin GPIO Pin Header
3	12V 1A Output
4	40-Pin GPIO Pin Header
5	M.2 B Interface
6	FPC DSI Interface Note: Only ED-IPC2120 include this interface
7	RTC Battery Base
8	USB 2.0 Pin Header
9	Speaker Interface Note: Only ED-IPC2120 include this interface
10	CSI Interface Note: Only ED-IPC2120 include this interface
11	FPC HDMI Interface Note: Only ED-IPC2120 include this interface

1.6.11.1 5V 1A Output

The motherboard of ED-IPC2100 series device includes an extended 5V 1A power output port with 3-Pin 2.0mm spacing white WTB connector, which is reserved for the extended LCD screen to supply power. The pins are defined as follows:

	Pin ID	Pin Name
	1	GND
	2	5V
	3	GND

1.6.11.2 10-Pin GPIO

The motherboard of ED-IPC2100 series device includes a 10-Pin GPIO Pin Header with 2x5-Pin 2.54mm spacing, which is used to lead out the extended GPIO port. The user can customize the extension, and the pins definition are as follows:

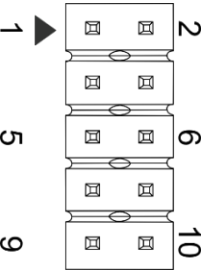
	Pin ID	Pin Name
	1	EXIO_P10
	2	3V3
	3	EXIO_P12
	4	EXIO_P11
	5	EXIO_P14
	6	EXIO_P13
	7	EXIO_P16
	8	EXIO_P15
	9	GND
	10	EXIO_P17

1.6.11.3 12V 1A Output

The motherboard of ED-IPC2100 series device includes 3 expanded 12V 1A power output ports with 2-Pin 2.0mm white WTB connector, which is reserved for the extended LCD screen to supply power. The pins are defined as follows:

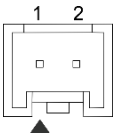
	Pin ID	Pin Name
	1	GND
	2	12V

1.6.11.4 40-Pin GPIO

The motherboard of ED-IPC2100 series device includes a 40-Pin GPIO terminal with 2x20-Pin 2.54mm spacing, which is used to lead out the GPIO port of CM4, and reserves to connect the extended accessories. The pins are defined as follows:

	Pin ID	Pin Name	Pin ID	Pin Name
	1	3V3_EXT	2	5V2_CM4
	3	GPIO2	4	5V2_CM4
	5	GPIO3	6	GND
	7	GPIO4	8	GPIO14
	9	GND	10	GPIO15
	11	GPIO17	12	GPIO18
	13	GPIO27	14	GND
	15	GPIO22	16	GPIO23
	17	3V3_EXT	18	GPIO24
	19	GPIO10	20	GND
	21	GPIO9	22	GPIO25
	23	GPIO11	24	GPIO8
	25	GND	26	GPIO7
	27	GPIO0	28	GPIO1
	29	GPIO5	30	GND
	31	GPIO6	32	GPIO12
	33	GPIO13	34	GND
	35	GPIO19	36	GPIO16
	37	GPIO26	38	GPIO20
	39	GND	40	GPIO21

Note: GPIO4~GPIO9, GPIO12, GPIO13 and GPIO22~GPIO27 has been used for other specific functions. If you need to use the function of its ordinary IO, you need to remove the jumper resistance on the corresponding signal line.

1.6.11.5 M.2 B Interface

The motherboard of ED-IPC2100 series device includes a M.2 B Key connector, which is used for external SSD and compatible with M.2 B 2230 and M.2 B 2242 SSD.

1.6.11.6 FPC DSI Interface (optional)

The motherboard of ED-IPC2100 series device includes one extended DSI interface, 30-pin 0.5mm FPC connector and 4-Lane DSI signal. It supports the output of MIPI display signal to LCD screen, reserves to connect the extended LCD screen. It supports USB/I2C touch screen and backlight adjustment, and the pins are defined as follows:

**NOTE:**

Only ED-IPC2120 include this interface.

Pin ID	Pin Name	Pin ID	Pin Name
1	GND	2	USB_DM_LCD
3	USB_DP_LCD	4	GND
5	GND	6	SCL_LCD
7	SDA_LCD	8	GND
9	TPINT_L	10	GND
11	GND	12	DSI1_D0_N
13	DSI1_D0_P	14	GND
15	GND	16	DSI1_D1_N
17	DSI1_D1_P	18	GND
19	GND	20	DSI1_CLK_N
21	DSI1_CLK_P	22	GND
23	GND	24	DSI1_D2_N
25	DSI1_D2_P	26	GND
27	GND	28	DSI1_D3_N
29	DSI1_D3_P	30	GND

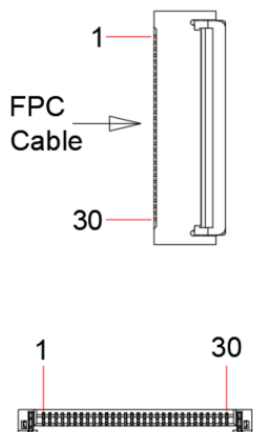

1.6.11.7 RTC Battery Base

The motherboard of ED-IPC2100 series device is integrated with RTC. For the version sold in China, we will install CR1220 battery (RTC backup power supply) by default.

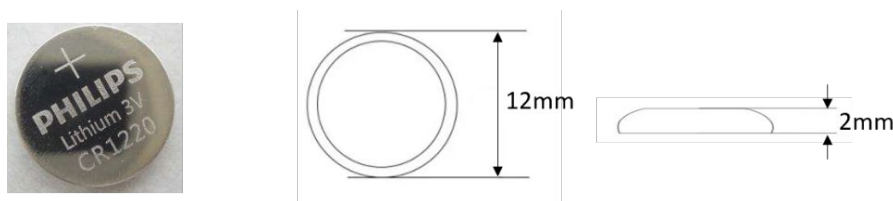

RTC can ensure that the system has an uninterrupted and reliable clock, which is not affected by factors such as the device is power down.

**TIP:**

Some international logistics do not support the transportation of batteries, and some ex-factory

devices are not equipped with CR1220 batteries. Therefore, before using RTC, please prepare a CR1220 battery and install it on the motherboard.

1.6.11.8 USB 2.0 Interface

The motherboard of ED-IPC2100 series device includes an extended USB 2.0 Pin Header with 5-Pin 1.5mm spacing WTB connector. It is used to expand a USB 2.0 interface, the pins are defined as follows:

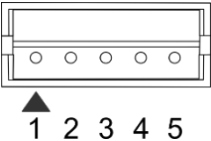
	Pin ID	Pin Name
	1	VBUS
	2	USB_DM
	3	USB_DP
	4	GND
5	GND	

1.6.11.9 Speaker Interface (optional)

The motherboard of ED-IPC2100 series device includes one extended Speaker output with 4-Pin 2.0mm spacing WTB connector. Dual-channel stereo output, which can be extended to connect two 4Ω 3W stereo speakers. The pins are defined as follows:



Note:

Only ED-IPC2120 include this interface.

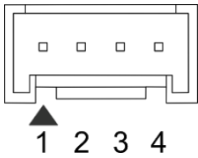
	Pin ID	Pin Name
	1	R+
	2	R-
	3	L+
4	L-	

1.6.11.10 CSI Interface (optional)

The motherboard of ED-IPC2100 series device includes one extended CSI interface, 2x15-Pin 0.4mm spacing connector and 2-Lane CSI signal. It is used to expand the connection of 800M CSI camera, the pins are defined as follows:



Note:

Only ED-IPC2120 include this interface.

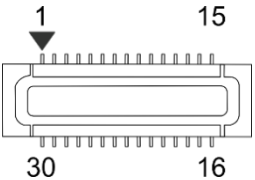
	Pin ID	Pin Name	Pin ID	Pin Name
	1	NC	2	NC
	3	1V8_CM4	4	1V2_CSI
	5	1V8_CM4	6	GND
	7	CSI_MCLK	8	GND
	9	GND	10	2V8_CSI
	11	NC	12	NC
	13	NC	14	NC
	15	GND	16	GND
	17	NC	18	NC
	19	GND	20	CSI_D1_N
	21	CSI_D1_P	22	GND
	23	CSI_D0_N	24	CSI_D0_P
	25	GND	26	CSI_CLK_N
	27	CSI_CLK_P	28	GND
	29	SCL_1V8	30	SDA_1V8

1.6.11.11 FPC HDMI Interface (optional)

The motherboard of ED-IPC2100 series device includes one extended HDMI interface with 40-pin 0.5mm spacing FPC connector. It supports video signal output to LCD screen, reserves to connect the extended LCD screen. It supports USB/I2C touch screen and backlight adjustment. The pins are defined as follows:



Note:

Only ED-IPC2120 include this interface.

Pin ID	Pin Name	Pin ID	Pin Name
1	NC	2	NC
3	NC	4	NC
5	NC	6	NC
7	NC	8	GND
9	HDMI1_CLKN	10	HDMI1_CLKP
11	GND	12	GND
13	HDMI1_TX0N	14	HDMI1_TX0P
15	GND	16	GND
17	HDMI1_TX1N	18	HDMI1_TX1P
19	GND	20	GND
21	HDMI1_TX2N	22	HDMI1_TX2P
23	GND	24	GND
25	HDMI1_CEC	26	GND
27	HDMI1_SCL	28	HDMI1_SDA
29	GND	30	HDMI1_HPD
31	GND	32	TPINT_L
33	GND	34	SDA_LCD
35	SCL_LCD	36	GND
37	GND	38	USB_DP_LCD
39	USB_DM_LCD	40	GND

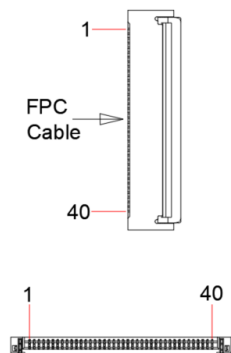

2 Installing Components

This chapter describes how to install optional components.

- ✓ Installing Internal Components
- ✓ Installing Other Components

2.1 Installing Internal Components (optional)

Before installing the internal components, it is necessary to open the device case.

2.1.1 Open Device Case

Preparation:

A cross screwdriver has been prepared.

Steps:

1. Pull out the default configuration of phoenix connector (male for wiring).
2. Use a screwdriver to loosen two M3 screws on two sides counterclockwise, as shown in the red mark in the figure below.



3. Remove the front cover to the right, as shown in the figure below.



4. Use a screwdriver to loosen four M2.5 screws and one grounding screw on two sides counterclockwise, as shown in the red mark in the figure below.



5. Remove the upper cover upward and turn it to the antenna port side, as shown in the figure below.



2.1.2 Install RTC battery



Some international logistics do not support the transportation of batteries, and some ex-factory devices are not equipped with CR1220 batteries. Therefore, before using RTC, please prepare a CR1220 battery and install it on the motherboard.

Preparation:

- The device case has been opened.
- The CR1220 battery has been prepared.

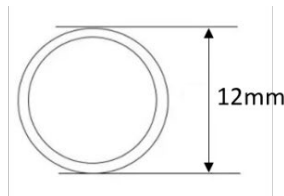

Steps:

1. Locate the RTC battery base where the battery is to be installed, as shown in the red box below.



2. Put the positive pole of the battery upwards and press it into the RTC base. The installation effect is as shown below.

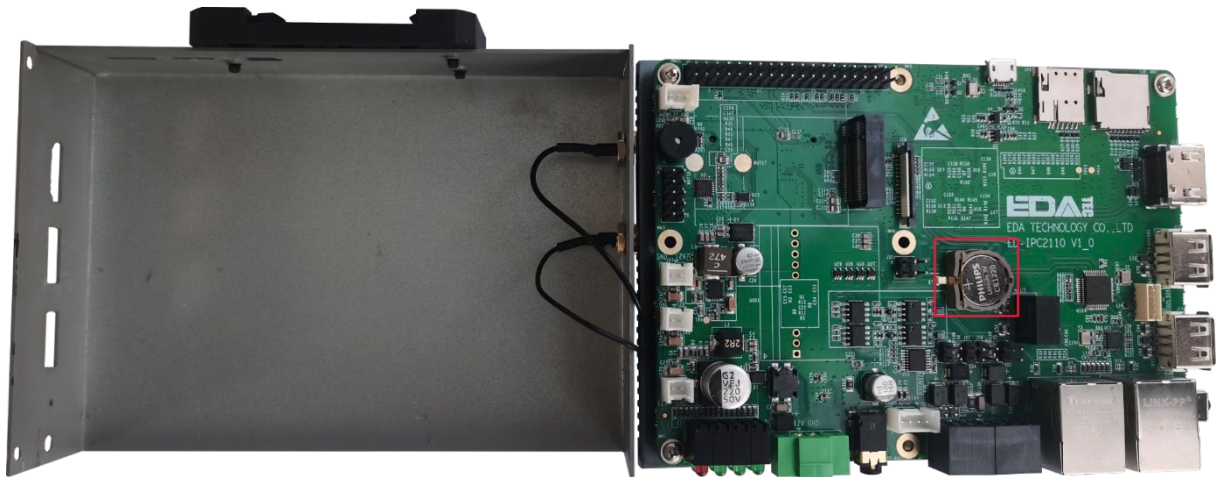

2.1.3 Close Device Case

Preparation:

A cross screwdriver has been prepared.

Steps:

1. Turn the upper cover downwards, align the ports on PCBA with the ports on each side panel and close the upper cover.



2. Align the screw holes on the upper and side panels, and use a screwdriver to tighten four M2.5 screws and one grounding screw on two sides clockwise, as shown in the following figure.



3. Align the ports on PCBA with the ports on the front panel, insert the front cover, and then use a screwdriver to fasten two M3 screws clockwise, as shown in the following figure.



4. Plug in the default configuration of phoenix connector.

2.2 Installing Other Components

If the selected ED-IPC2100 series device includes 4G and WiFi functions, the SIM card and antenna need to be installed before using the device.

2.2.1 Install Antenna (optional)

Preparation:

The corresponding antennas have been obtained from the packaging box. If there are multiple antennas, they can be distinguished by the labels on the antennas.

Steps:

1. Locate the antenna port where the antenna is to be installed, as shown in the red box in the figure below.



2. Align the ports on both sides of the device and the antenna, and tighten them clockwise to ensure that they will not fall off.

2.2.2 Install Micro SD Card

Preparation:

The Micro SD card to be used has been obtained.

Steps:

1. Locate the Micro SD card slot where the Micro SD is to be installed, as shown in the red box below.



2. Insert the Micro SD card with the front face down into the corresponding card slot, and hear a sound to indicate that the installation is complete.

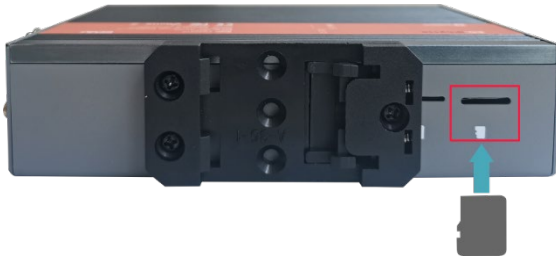

2.2.3 Install Nano SIM Card (optional)

Preparation:

The 4G Nano SIM card to be used has been obtained.

Steps:

1. Use a cross screwdriver to loosen three screws on the DIN-rail bracket counterclockwise (red box position in the figure below) and remove the default DIN-Rail bracket.



2. Locate the Nano SIM card slot where the Nano SIM card is to be installed, as shown in the red box below.



3. Insert the Nano SIM card into the corresponding card slot with the chip side up, and hear a sound to indicate that the installation is complete.



4. Install the DIN-Rail bracket onto the device case.

3 Installing Device

This chapter introduces how to install the device.

- ✓ DIN-Rail Installation

3.1 DIN-Rail Installation

When the ED-IPC2100 series device leaves the factory, the DIN-rail bracket is installed as standard by default.

Steps:

1. Face the side of the DIN-rail bracket to the rail to be installed, and the upper side of the bracket is sleeved on the upper side of the rail.

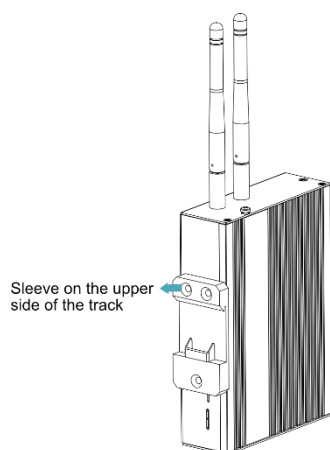

2. Press down the buckle on the lower side of the DIN-rail bracket until the bracket can be buckled on the rail, and the installation is completed.

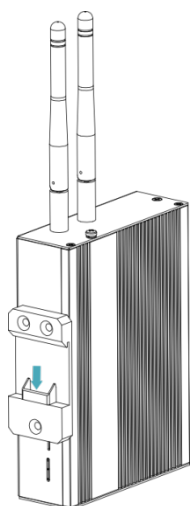

4 Booting The Device

This chapter introduces how to connect cables and boot the device.

- ✓ Connecting Cables
- ✓ Booting The System For The First Time

4.1 Connecting Cables

This section describes how to connect cables.

Preparation:

- ◆ Accessories such as display, mouse, keyboard and power adapter that can be used normally have been ready.
- ◆ A network that can be used normally.
- ◆ Get the HDMI cable and network cable that can be used normally.

Schematic diagram of connecting cables:

Please refer to [1.6 Interfaces](#) for the pin definition of each interface and the specific method of wiring.

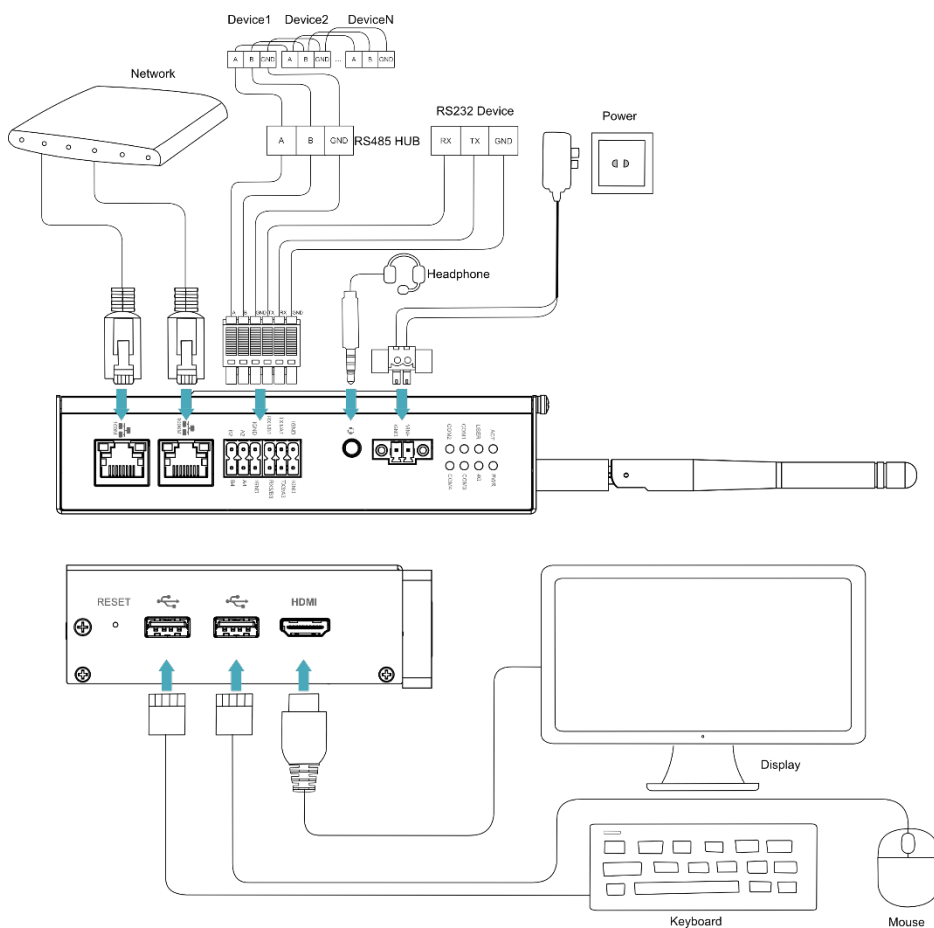

4.2 Booting The System For The First Time

ED-IPC2100 series device has no switching power supply. After the power supply is connected, the system will start.

- ◆ The red PWR indicator is on, indicating that the device has been powered normally.
- ◆ The green ACT indicator is blinking, indicating that the system is started normally, and then the logo of Raspberry Pi will appear in the upper left corner of the screen.



TIP:

Default username is pi, Default password is raspberry.

4.2.1 Raspberry Pi OS (Desktop)

If the Desktop version of the system is installed when the product leaves the factory, after the device is started, it will directly enter the desktop, as shown in the following figure.

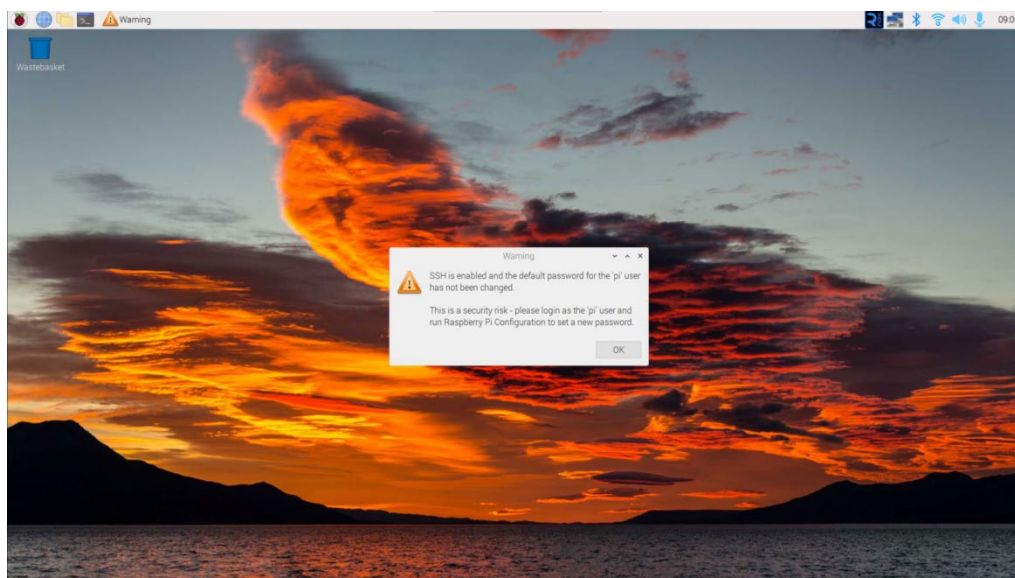

4.2.2 Raspberry Pi OS (Lite)

If the Lite version of the system is installed at the factory, the default username pi will be used to automatically log in after the device is started, and the default password is raspberry. The following figure shows that the system has been started normally.

```
[ OK ] Started LSB: rng-tools (Debian variant).
[ OK ] Started WPA supplicant.
[ OK ] Started Authorization Manager.
[ OK ] Reached target Network.
[ OK ] Listening on Load/Save RF Kill Switch Status /dev/rfkill Watch.
Starting Modem Manager...
Starting /etc/rc.local Compatibility...
Starting Permit User Sessions...
[ OK ] Finished Remove Stale Onlimext4 Metadata Check Snapshots.
[ OK ] Started /etc/rc.local Compatibility.
Starting Load/Save RF Kill Switch Status...
[ OK ] Finished Permit User Sessions.
[ OK ] Started Getty on tty1.
[ OK ] Reached target Login Prompts.
[ OK ] Started Load/Save RF Kill Switch Status.
[ OK ] Started User Login Management.
Starting Save/Restore Sound Card State...
[ OK ] Finished Save/Restore Sound Card State.
[ OK ] Reached target Sound Card.
[ OK ] Started Modem Manager.
[ OK ] Started LSB: Switch to on= (unless shift key is pressed).

Raspbian GNU/Linux 11 raspberrypi tty1

raspberrypi login: pi
Password:
Linux raspberrypi 6.1.21-08+ #1642 SMP PREEMPT Mon Apr 3 17:24:16 BST 2023 aarch64

The programs included with the Debian GNU/Linux system are free software;
the exact distribution terms for each program are described in the
individual files in /usr/share/doc/*/copyright.

Debian GNU/Linux comes with ABSOLUTELY NO WARRANTY, to the extent
permitted by applicable law.
Last login: Tue Jul 11 11:15:28 BST 2023 on tty1

Wi-Fi is currently blocked by rfkill.
Use raspi-config to set the country before use.

pi@raspberrypi:~$ ~
```

5 Configuring System

This chapter introduces how to configure system.

- ✓ Finding Device IP
- ✓ Remote Login
- ✓ Configuring Storage Devices
- ✓ Configuring Ethernet IP
- ✓ Configuring WiFi (Optional)
- ✓ Configuring Bluetooth (optional)
- ✓ Configuring 4G (Optional)
- ✓ Configuring Buzzer
- ✓ Configuring RTC
- ✓ Configuring Serial Port
- ✓ Configuring Audio (Optional)
- ✓ Configuring USER Indicator

5.1 Finding Device IP

In some application scenarios, it is necessary to remotely log in or manage devices, so it is necessary to obtain the device IP.

5.1.1 Query IP by Using ifconfig Command

After the device is started normally and the display is connected, you can use the ifconfig command to view the current device IP.

Preparation:

ED-IPC2100 device has been connected to the network through the router.

Steps:

Run the following command in the command pane to view the detailed information of each port of the device, where the inet value in the eth1 interface is the device IP, as shown in the following figure.

ifconfig

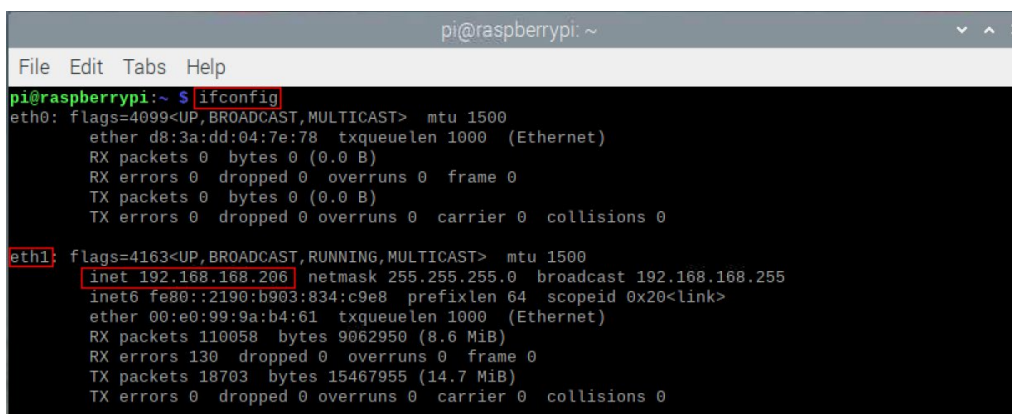

```

pi@raspberrypi: ~
File Edit Tabs Help
pi@raspberrypi:~$ ifconfig
eth0: flags=4099<UP,BROADCAST,MULTICAST> mtu 1500
    ether d8:3a:dd:04:7e:78 txqueuelen 1000 (Ethernet)
    RX packets 0 bytes 0 (0.0 B)
    RX errors 0 dropped 0 overruns 0 frame 0
    TX packets 0 bytes 0 (0.0 B)
    TX errors 0 dropped 0 overruns 0 carrier 0 collisions 0

eth1: flags=4163<UP,BROADCAST,RUNNING,MULTICAST> mtu 1500
    inet 192.168.168.206 netmask 255.255.255.0 broadcast 192.168.168.255
    inet6 fe80::2190:b903:834:c9e8 prefixlen 64 scopeid 0x20<link>
    ether 00:e0:99:9a:b4:61 txqueuelen 1000 (Ethernet)
    RX packets 110058 bytes 9062950 (8.6 MiB)
    RX errors 130 dropped 0 overruns 0 frame 0
    TX packets 18703 bytes 15467955 (14.7 MiB)
    TX errors 0 dropped 0 overruns 0 carrier 0 collisions 0
  
```



NOTE:

If the two Ethernet ports of ED-IPC2100 are all connected to Ethernet, the two IP addresses found are all device IP addresses.

5.1.2 Login Router to Query IP

When the device starts normally but the display is not connected, you can log in to the router to check

the current device IP.

Preparation:

- ◆ ED-IPC2100 has been connected to the network through the router.
- ◆ The IP and network password of the router in the network have been obtained, and the IP address is 192.168.X.X.

Steps:

1. Open a browser, Enter the router IP of the network where ED-IPC2100 is located in the address bar: 192.168.x.x, and press Enter to enter the router login interface.
2. According to the interface prompts, enter the network password and enter the router management interface.
3. Find the IP address of ED-IPC2100 in the terminal device of the management interface.

5.1.3 Scan For Using NMAP Tool

When the device starts normally but the display is not connected, you can use nmap tool to scan the IP under the current network to obtain the IP information of the device. Nmap supports Linux, macOS, Windows and other platforms.

Preparation:

- ◆ ED-IPC2100 has been connected to the network through the router.
- ◆ The IP segment and mask of the router in the network have been obtained, for example, 192.168.X.X/24, where 24 is the subnet mask.

Steps:

For example, using nmap to scan the network segments from 192.168.3.0 to 255, you can use the following steps:

1. Open the nmap tool and scan the hosts in the 192.168.X.X/24 network segment.

**NOTE:**

The nmap tool operates differently in different operating systems, so please follow the actual interface or command prompts.

2. According to the scanned results, get the device IP of ED-IPC2100.

5.2 Remote Login

There are many remote login methods, and users can choose according to their actual needs. This chapter only introduces SSH and VNC.

5.2.1 Connect To The Device Via SSH

If the device uses Lite system, you can choose to connect to the device remotely through SSH to configure or debug it.

The tools for remote login are selected by users themselves, and the following is an example of logging in through MobaXterm.

Preparation:

- ◆ The MobaXterm tool has been installed on the PC.
- ◆ ED-IPC2100 has been connected to the network through the router.
- ◆ IP address of ED-IPC2100 has been get.

Steps:

1. Open MobaXterm, click  Session, and open the window for creating connection, as shown in the figure below.



2. Click  SSH in the upper left corner to open the SSH connection interface.

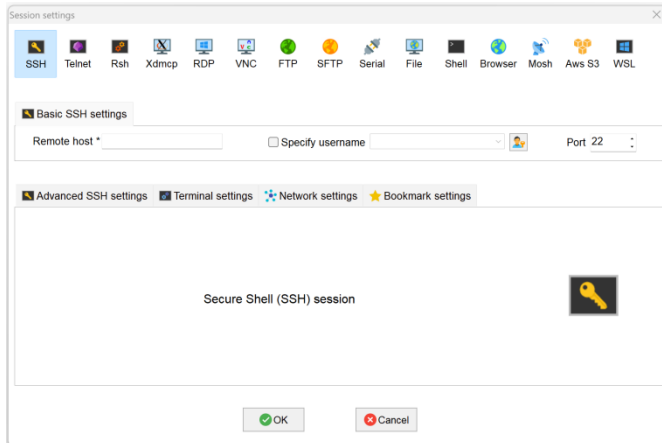

3. After entering the IP address of the obtained ED-IPC2100, click "OK".

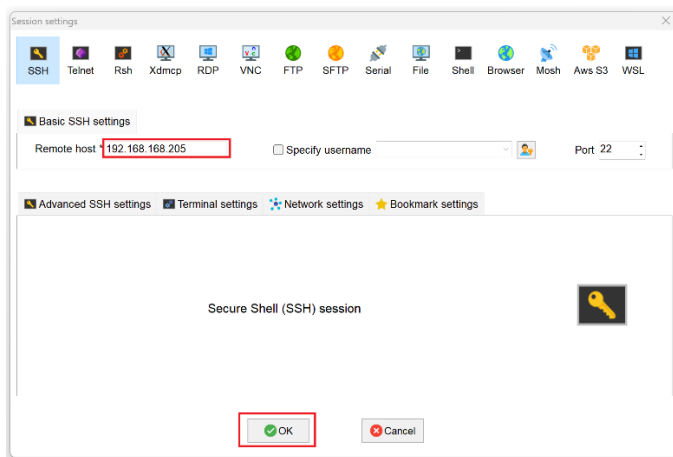

4. Click "Accept" in the pop-up prompt box to enter the system login interface.
5. Enter the username and password according to the prompt, and enter the system after logging in.



TIP:

Default username is pi, Default password is raspberry.

```
login as: pi
pi@192.168.168.205's password:

+ MobaXterm Personal Edition v23.0 +
+ (SSH client, X server and network tools)
+
+ SSH session to pi@192.168.168.205
+ Direct SSH : ✓
+ SSH compression : ✓
+ SSH-browser : ✓
+ X11-forwarding : ✓ (remote display is forwarded through SSH)
+
+ For more info, ctrl+click on help or visit our website.

linux raspberrypi 5.10.92-v8+ #1514 SMP PREEMPT Mon Jan 17 17:39:38 GMT 2022 aarch64
The programs included with the Debian GNU/Linux system are free software;
the exact distribution terms for each program are described in the
individual files in /usr/share/doc/*/copyright.
Debian GNU/Linux comes with ABSOLUTELY NO WARRANTY, to the extent
permitted by applicable law.
Last login: Sat May 6 10:07:19 2023 from 192.168.168.227
SSH is enabled and the default password for the 'pi' user has not been changed.
This is a security risk - please login as the 'pi' user and type 'passwd' to set a new password.

pi@raspberrypi:~$
```

5.2.2 Connect To The Device Desktop Through VNC

If the device uses Desktop system, you can choose to connect to the device remotely through VNC to configure or debug it.

Preparation:

- ◆ The RealVNC Viewer tool has been installed on PC.
- ◆ ED-IPC2100 has been connected to the network through the router.
- ◆ IP address of ED-IPC2100 has been get.
- ◆ The VNC function in the ED-IPC2100 system has been turned on, as shown in the following figure.

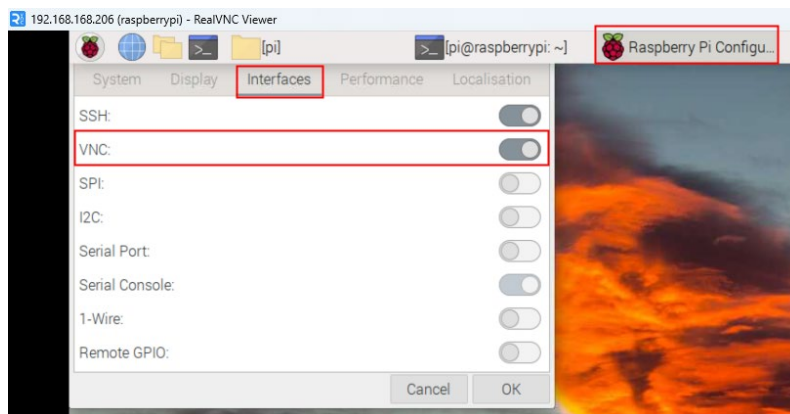

Steps:

1. Open RealVNC Viewer and select "New connection..." in the File in the menu bar to open the window for creating a connection, as shown in the following figure.

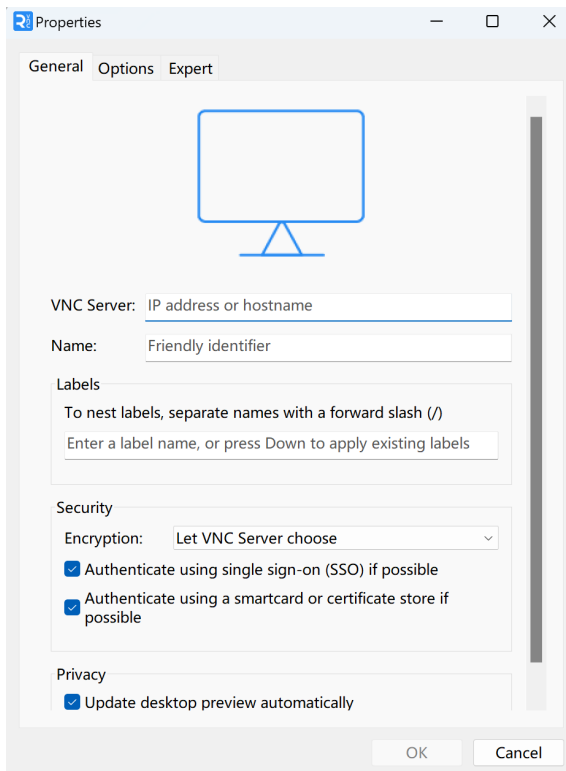

2. After entering the IP address of ED-IPC2100, click "OK".

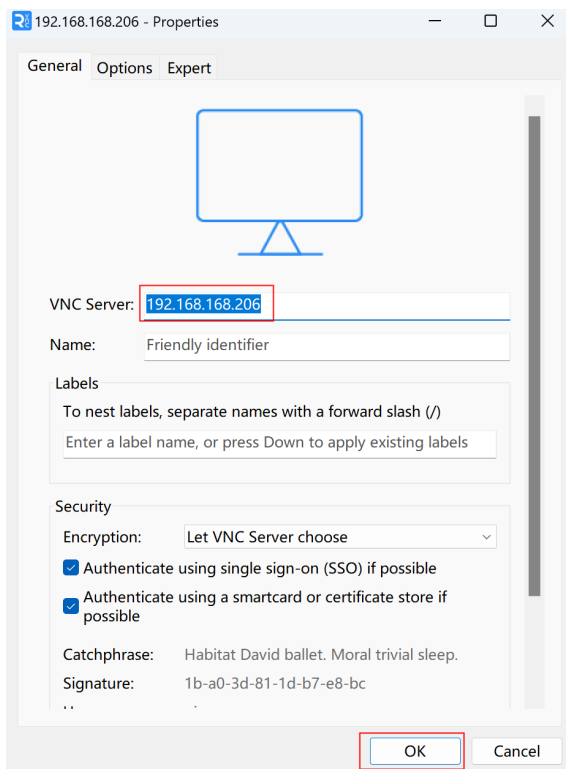

3. Enter the username and password in the Authentication prompt box that pops up.

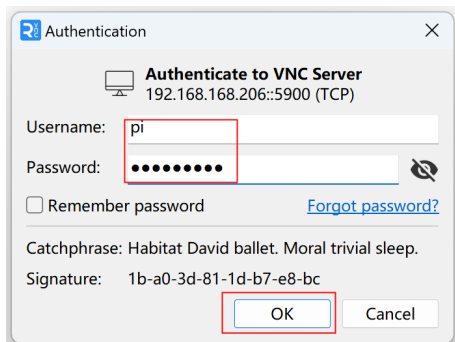
**TIP:****Default username is pi, Default password is raspberry.**

4. Select "OK" to log in and connect to the remote desktop.

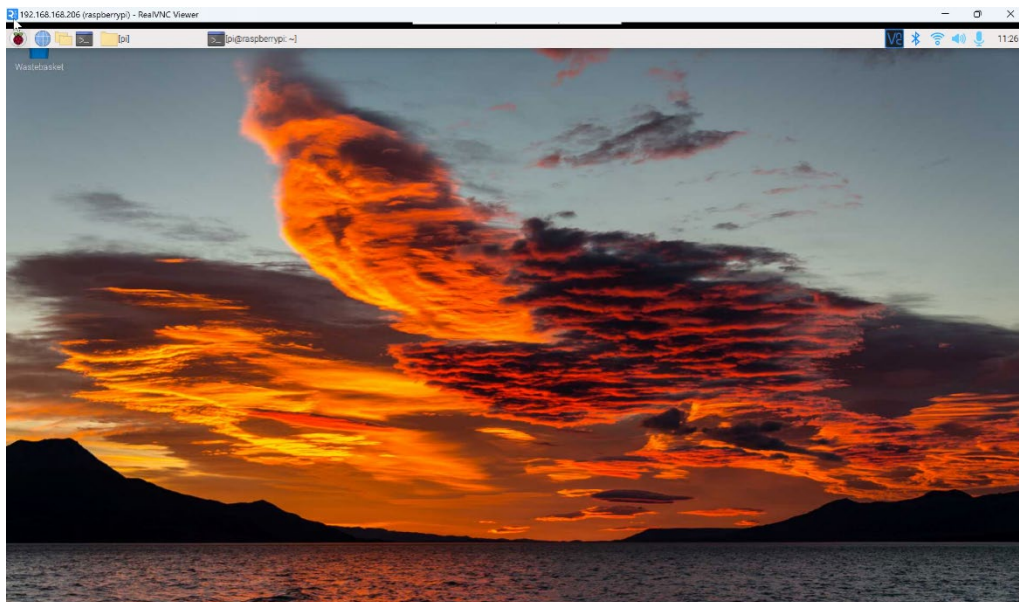

5.3 Configuring Storage Devices

You can connect your external hard disk, SSD, SD card or USB stick to the corresponding port on the ED-IPC2100, and mount the file system to access the data stored on it. When the ED-IPC2100 device is turned off, it is necessary to unmount the storage device so that it can be safely pulled out.

The connectable storage devices of ED-IPC2100 include USB storage devices and SD cards. This chapter introduces how to configure the mounting and unmounting of storage devices.

5.3.1 Mounting a Storage Device

If the Lite version of the operating system is used (the Desktop version of the system supports automatic mounting), after the storage device is connected to the corresponding port on the ED-IPC2100, it is necessary to mount the storage device in a specific folder location through configuration, usually in the /mnt folder, such as /mnt/mydisk.



NOTE:

The "/mnt" folder must be empty.

Preparation:

The storage device is ready to be mounted.

Steps:

1. Connect the storage device to be mounted to the corresponding port on the ED-IPC2100 (USB storage device is inserted into USB port and SD card is inserted into SD card slot).
2. Run the following command to view all disk partitions on the ED-IPC2100.

```
sudo lsblk -o UUID,NAME,FSTYPE,SIZE,MOUNTPOINT,LABEL,MODEL
```

After running the command, the information displayed is as follows:

```
pi@raspberrypi:~$ sudo lsblk -o UUID,NAME,FSTYPE,SIZE,MOUNTPOINT,LABEL,MODEL
UUID                                NAME      FSTYPE  SIZE MOUNTPOINT  LABEL  MODEL
7C9E-4F13                            sda              3.8G
                                sda1          vfat    3.8G /media/pi/ADMESY ADMESY
C336-AC83                            mmcblk0              7.3G
                                |-mmcblk0p1  vfat    256M /boot          bootfs
eaaa4faa-eab6-400c-950f-dc96ae4e0400 |-mmcblk0p2  ext4     7G /              rootfs
                                mmcblk0boot0  4M
                                mmcblk0boot1  4M
```

- UUID、NAME、FSTYPE、SIZE、MOUNTPOINT、LABEL and MODEL are disk parameters

that need to be listed.

- The types of MOUNTPOINT are “/” and “/boot” .
 - The storage device whose LABEL is "ADMESY" is the inserted USB storage device, and the corresponding disk name is sda1.
 - FSTYPE indicates the file system type contained.
- ✓ If the file system type of the inserted storage device is exFAT, please run the following commands to install the exFAT driver.

sudo apt update

sudo apt install exfat-fuse

- ✓ If the file system type of the inserted storage device is NTFS (only read permission is supported), you can install ntfs-3g driver to realize write permission. Run the following commands to install ntfs-3g drivers.

sudo apt update

sudo apt install ntfs-3g

3. Run the following command to get the location of the disk partition.

sudo blkid

After running the command, the following information is displayed, which the disk partition of the connected storage device is displayed as "/dev/sda1".

```
pi@raspberrypi:~$ sudo blkid
/dev/mmcblk0p1: LABEL_FATBOOT="bootfs" LABEL="bootfs" UUID="C336-AC83" BLOCK_SIZE="512" TYPE="vfat"
PARTUUID="7902e585-01"
/dev/mmcblk0p2: LABEL="rootfs" UUID="eaaa4faa-eab6-400c-950f-dc96ae4e0400" BLOCK_SIZE="4096" TYPE="
ext4" PARTUUID="7902e585-02"
/dev/sda1: LABEL="ADMESY" UUID="7C9E-4F13" BLOCK_SIZE="512" TYPE="vfat"
```

4. Create a target folder as the mount point of the storage device. Assuming that the mount name is mydisk and the directory to be mounted is "/mnt", the command to be executed is as follows:

sudo mkdir /mnt/mydisk

5. Mount the storage device at the created mount point, and execute the following command:

sudo mount /dev/sda1 /mnt/mydisk

6. Verify the success of mounting the storage device by executing the following command.

ls /mnt/mydisk

- ✓ After executing the command, if the displayed information lists all files in the storage device, it means that the mount is successful.
- ✓ After executing the command, if the displayed information does not list the contents of related files, it means that the mount is failed.

5.3.2 Unmount The Storage Device

When the ED-IPC2100 device is turned off, it is necessary to manually unmount the storage device so that it can be pulled out safely.



NOTE:

Both Lite and Desktop versions of the system need to manually unmount the storage device.

Preparation:

The storage device has been successfully mounted.

Steps:

If "/mnt" is the mounted directory and "mydisk" is the name of the mount point, you can execute the following command to complete the unmounting.

sudo umount /mnt/mydisk

- ✓ After executing the command, if no error message is displayed, it means that the unmounting has been completed and the storage device can be completely pulled out.
- ✓ After executing the command, if an error message is displayed, it means that the unmounting is failed.

5.3.3 Set The Storage Device To Mount Automatically

If you are using the Lite version of operating system, you can automatically mount it by modifying the fstab settings.

Preparation:

The storage device to be mounted has been connected to the corresponding port on the ED-IPC2100 device.

Steps:

1. Execute the following command to view all disk partitions on the ED-IPC2100 and get the file system type of the storage device to be mounted, as "vfat" shown in the figure below.

sudo lsblk -o UUID,NAME,FSTYPE,SIZE,MOUNTPOINT,LABEL,MODEL

```
pi@raspberrypi:~ $ sudo lsblk -o UUID,NAME,FSTYPE,SIZE,MOUNTPOINT,LABEL,MODEL
UUID                                NAME      FSTYPE  SIZE MOUNTPOINT  LABEL  MODEL
7C9E-4F13                            sda              3.8G
|-sda1                                vfat          3.8G /media/pi/ADMESY ADMESY  Flash_Disk
mmcb1k0                                7.3G
|-mmcb1k0p1                          vfat          256M /boot      bootfs
|-mmcb1k0p2                          ext4           7G /         rootfs
mmcb1k0boot0                          4M
mmcb1k0boot1                          4M
```

2. Execute the following command to obtain the UUID of the storage device to be mounted, such as "7C9E-4F13" in the figure below.

sudo blkid

```
pi@raspberrypi:~ $ sudo blkid
/dev/mmcb1k0p1: LABEL_FATBOOT="bootfs" LABEL="bootfs" UUID="C336-AC83" BLOCK_SIZE="512" TYPE="vfat"
PARTUUID="7902e585-01"
/dev/mmcb1k0p2: LABEL="rootfs" UUID="eaaa4faa-eab6-400c-950f-dc96ae4e0400" BLOCK_SIZE="4096" TYPE="
ext4" PARTUUID="7902e585-02"
/dev/sda1: LABEL="ADMESY" UUID="7C9E-4F13" BLOCK_SIZE="512" TYPE="vfat"
```

3. Execute the following command to open the fstab file.

sudo nano /etc/fstab

4. Add the following to the fstab file.

```
UUID=7C9E-4F13 /mnt/mydisk vfat defaults,auto,users,rw,nofail 0 0
```

- ✓ The value of UUID is the value found in Step 2 above.
- ✓ "/mnt" is the directory to be mounted, and mydisk is the name of the mount point.
- ✓ Vfat is the file system type queried in step 1.
- ✓ If the type of file system is FAT or NTFS, the added content is "UUID = 7C9E-4F13 /mnt/mydisk vfat defaults,auto,users,rw,no fail umask = 000 0 0", which will allow all users to "read/write" access to each file on the storage device.



NOTE:

More information about the **fstab** command can be viewed by executing the **man fstab** command.

5. Use Ctrl+X to save the file and exit edit mode.

5.4 Configuring Ethernet IP

The IP address is automatically obtained by default. If you need to reconfigure the IP, you can configure it through NetworkManager and dhcpcd.

5.4.1 Configure IP by Using The NetworkManager Tool

The operating systems of Desktop and Lite have enabled NetworkManager by default, which can be directly configured by using NetworkManager.

5.4.1.1 Raspberry Pi OS(Desktop)

In the Desktop version of the operating system, it is recommended to use the graphical NetworkManager tool to configure IP.



NOTE:

The Desktop version of the operating system has the NetworkManager graphical tool installed by default.

Preparation:

NetworkManager is enabled.

Steps:

1. Right-click the NetworkManager icon  and select "Edit Connections..." from the menu.

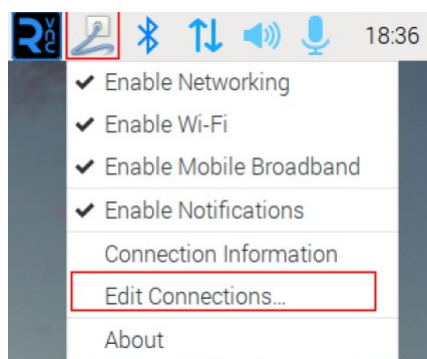

2. In the pop-up "Network Connections" pane, select the connection name to be modified, and then click the Settings button below.

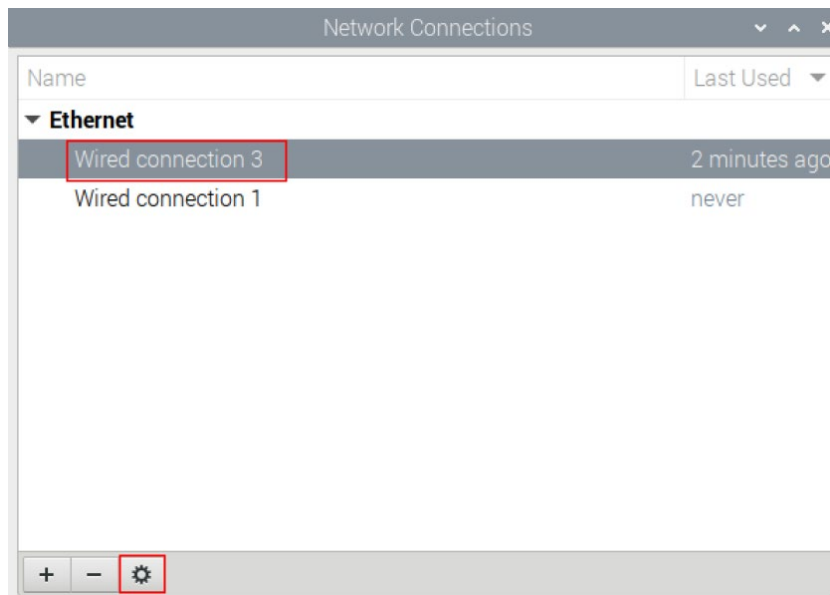

3. In the pop-up "Editing Wired connection" pane, select the "IPv4 Settings" page, and then set the IP address as required.
 - If you want to set the IP as a static IP, set the "Method" as "Manual", add an entry in Addresses and enter the corresponding IP address information.

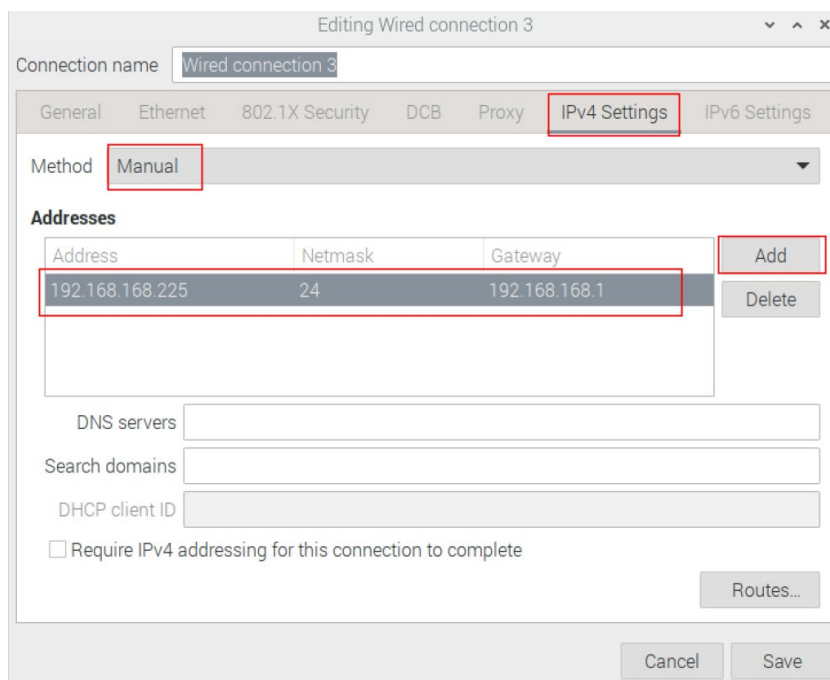

- If you want to set the IP to automatic acquisition mode, you only need to set the "Method" as "Automatic(DHCP)".

4. Click "save" to return to "Network Connections" pane and close the page.
5. Execute the **sudo reboot** command to restart the device.

5.4.1.2 Raspberry Pi OS(Lite)

In the Lite version of operating system, it is recommended to use the command to configure IP.

Preparation:

NetworkManager is enabled.

Steps:

Set a static IP address

1. Get the assigned IP address, subnet mask and gateway address, for example, the IP address is 192.168.1.101/24 and the gateway IP is 192.168.1.1.
2. Open the command terminal pane and execute the following command to set the IP address to the obtained IP address.

```
sudo nmcli connection modify <name> ipv4.addresses 192.168.1.101/24 ipv4.method manual
```

3. Execute the following command to set the gateway IP to the obtained gateway IP.

```
sudo nmcli connection modify <name> ipv4.gateway 192.168.1.1
```

Set the IP to automatic mode

Execute the following command to set the way of obtaining IP address to automatic mode.

```
sudo nmcli connection modify <name> ipv4.method auto
```

5.4.2 Configure IP by Using The dhcpd Tool

Since NetworkManager is enabled on the Desktop and Lite of operating systems by default. If you need to switch to using the dhcpd tool for configuration, you need to stop and disable the NetworkManager service and enable the dhcpd service before configuration.

Steps:

1. Execute the following command to stop the NetworkManager service.

```
sudo systemctl stop NetworkManager
```

2. Execute the following command to disable the NetworkManager service.

```
sudo systemctl disable NetworkManager
```

3. Execute the following command to enable the dhcpd service.

```
sudo systemctl enable dhcpd
```

4. Execute the following command to restart the device.

```
sudo reboot
```

5. Execute the following command to open the /etc/dhcpd.conf file.

```
sudo nano /etc/dhcpd.conf
```

6. Add the following content at the end of the /etc/dhcpd.conf file.

```
interface eth0  
static ip_address=192.168.168.210/24  
static routers=192.168.168.1  
static domain_name_servers=192.168.168.1 8.8.8.8 fd51:42f8:caae:d92e::1
```

- ✓ *eth0* is the Ethernet port of the IP to be configured;
- ✓ 192.168.0.10/24 indicates the IP address and subnet mask to be configured;

- ✓ 192.168.0.1 indicates the gateway IP to be configured;
- ✓ 8.8.8.8 represents the DNS server address, which should be configured according to the actual needs.
- ✓ fd51:42f8:caae:d92e::1 indicates the IPV6 address, which should be configured according to the actual needs.

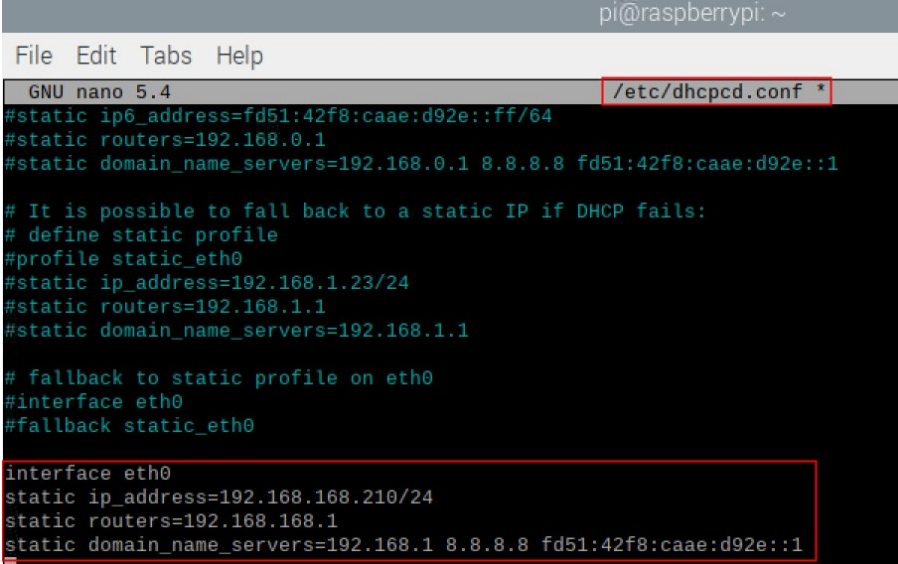

```
pi@raspberrypi: ~
File Edit Tabs Help
GNU nano 5.4 /etc/dhcpd.conf *
#static ip6_address=fd51:42f8:caae:d92e::ff/64
#static routers=192.168.0.1
#static domain_name_servers=192.168.0.1 8.8.8.8 fd51:42f8:caae:d92e::1

# It is possible to fall back to a static IP if DHCP fails:
# define static profile
#profile static_eth0
#static ip_address=192.168.1.23/24
#static routers=192.168.1.1
#static domain_name_servers=192.168.1.1

# fallback to static profile on eth0
#interface eth0
#fallback static_eth0

interface eth0
static ip_address=192.168.168.210/24
static routers=192.168.168.1
static domain_name_servers=192.168.1 8.8.8.8 fd51:42f8:caae:d92e::1
```

7. Use Ctrl+X to save the file and exit edit mode.

5.5 Configuring WiFi (Optional)

User can choose the ED-IPC2100 with WiFi version, which needs to be configured before using WiFi.

5.5.1 Enable WiFi Function

The WiFi function is blocked by default, and you need to set the country region to enable it.

5.5.1.1 Raspberry Pi OS(Desktop)

In the Desktop version of the operating system, you can use the desktop icon to open the configuration window for setting.

Steps:

1. Left-click the icon  in the upper right corner of the desktop and select "Click here to set Wi-Fi country" from the menu.



2. Set the value of Country in the pop-up "Wireless LAN Country" pane, and select it according to the actual region.

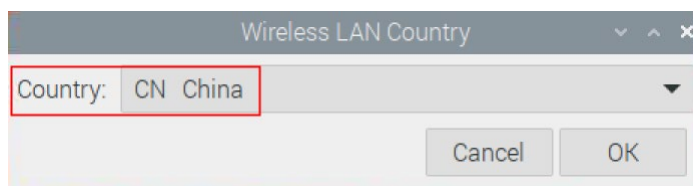

3. Select "OK" to complete the setting.

5.5.1.2 Raspberry Pi OS(Lite)

In the Lite version of the operating system, WiFi can be enabled through the command line.

Setps:

1. Open the command terminal pane and execute the following command to open the Raspberry Pi Software Configuration Tool (raspi-config) interface.

sudo raspi-config

2. Choose "5 Localisation Options" and press Enter.

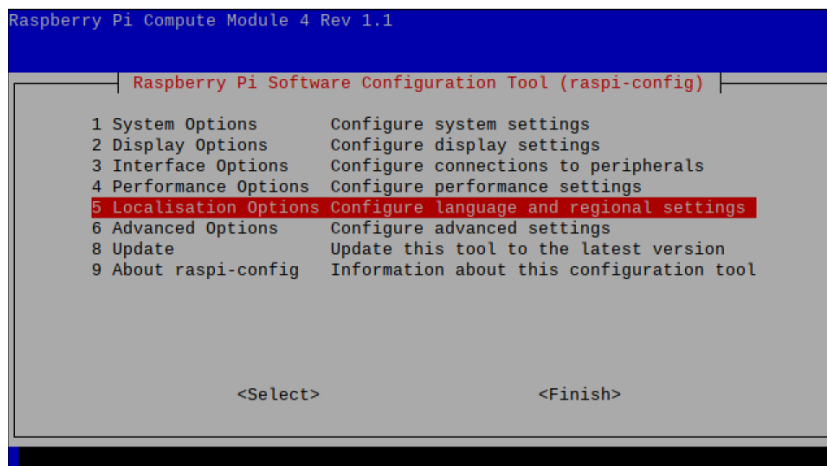

3. Select "L4 WLAN Country" and press Enter.

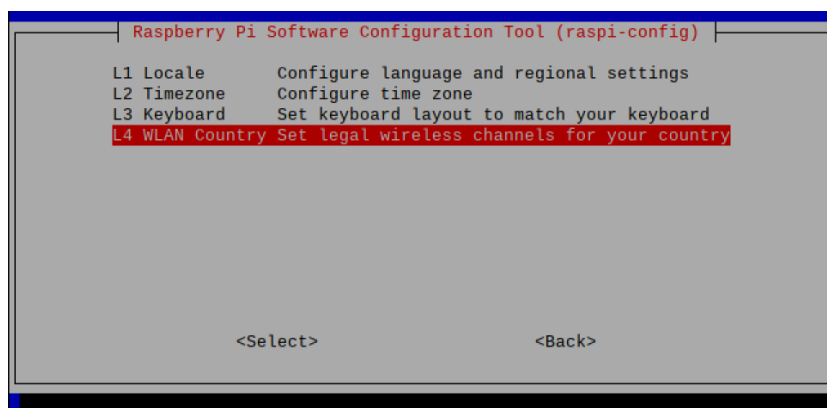

4. Select a country code according to the actual region and press Enter.

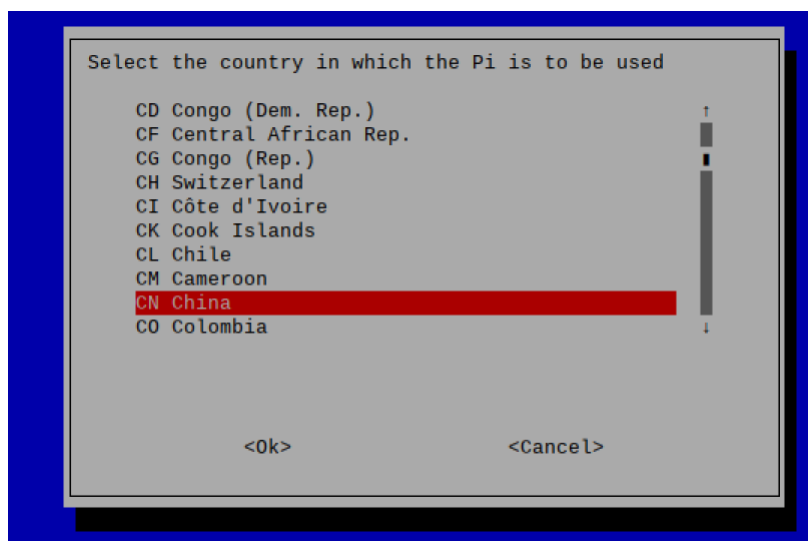

5. Open "Wireless LAN country set to CN" interface.



6. Press Enter to exit the main interface of the pane, select "Finish" and press Enter to complete the setting and return to the command line.

5.5.2 Use The NetworkManager Tool To Configure WiFi Connections

The operating systems of Desktop and Lite have enabled NetworkManager by default, which can be directly configured by using NetworkManager.

5.5.2.1 Raspberry Pi OS(Desktop)

In the Desktop version of the operating system, you can connect to WiFi through the desktop icon.

Preparation:

WiFi function is enabled.

Steps:

1. Left-click the  icon in the upper right corner of the desktop, select the WiFi to be connected in the pop-up WiFi list and click.

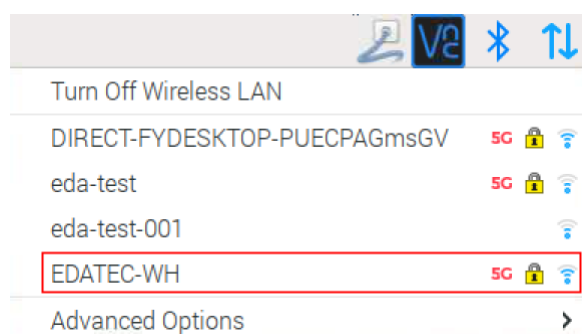

2. Enter the WiFi Password in the pop-up "Wi-Fi Network Authentication Required" pane.



3. Click "Connect" to connect to the network. After the connection is completed, the WiFi icon will be displayed normally in the upper right corner of the desktop.

5.5.2.2 Raspberry Pi OS(Lite)

In the Lite version of the operating system, it is supported to configure WiFi through the command line.

Preparation:

- WiFi function is enabled.
- The WiFi name and password that can be connected are prepared, for example, the WiFi name is SSID and the password is password.

Steps:

1. Open the terminal and execute the following command to scan the list of connectable WiFi name.

sudo nmcli device wifi

```

pi@raspberrypi:~$ sudo nmcli device wifi
IN-USE BSSID SSID MODE CHAN RATE
C2:82:9B:0A:F9:51 EDATEC-WH Infra 44 270 Mbit/s
D2:0F:0C:C8:83:49 DIRECT-FYDESKTOP-PUECPAGmsGV Infra 36 270 Mbit/s
C2:82:9B:0A:F9:4D EDATEC-WH Infra 6 130 Mbit/s
58:41:20:8B:16:B2 eda-test Infra 1 405 Mbit/s
5A:41:20:AB:16:B2 -- Infra 1 405 Mbit/s
5A:41:20:9B:16:B2 eda-test-001 Infra 1 405 Mbit/s
58:41:20:8B:16:B4 eda-test Infra 157 405 Mbit/s
5A:41:20:DB:16:B2 -- Infra 157 405 Mbit/s

```

2. Execute the following command to connect the WiFi to be accessed.

sudo nmcli device wifi connect *SSID* password *password*

Where SSID is the name of the WiFi to be connected and password is the password of the WiFi to be connected.

- Execute the following command to set up automatic WiFi connection.

```
sudo nmcli connection modify SSID connection.autoconnect yes
```

Where SSID is the name of the WiFi to be connected.

5.5.3 Configure WiFi Connection By Using dhcpcd Tool

In both Desktop and Lite versions of the operating system, you can connect to WiFi through the dhcpcd tool.

Preparation:

- WiFi function is enabled.
- The WiFi name and password that can be connected are prepared, for example, the WiFi name is EDATEC-WH and the password is password.

Steps:

- Open the terminal and execute the following command to open the Raspberry Pi Software Configuration Tool (raspi-config) interface.

```
sudo raspi-config
```

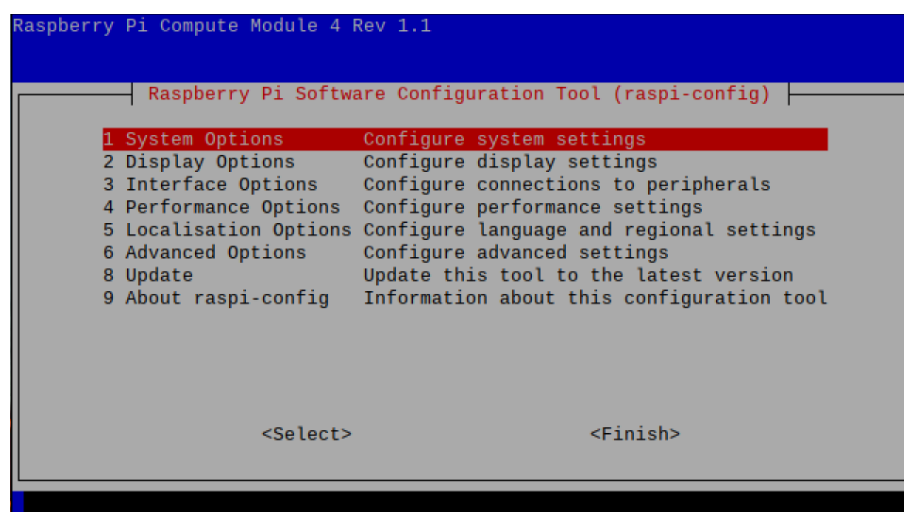

- Select "1 System Options" and press Enter, and then select "S1 Wireless LAN" in the interface.

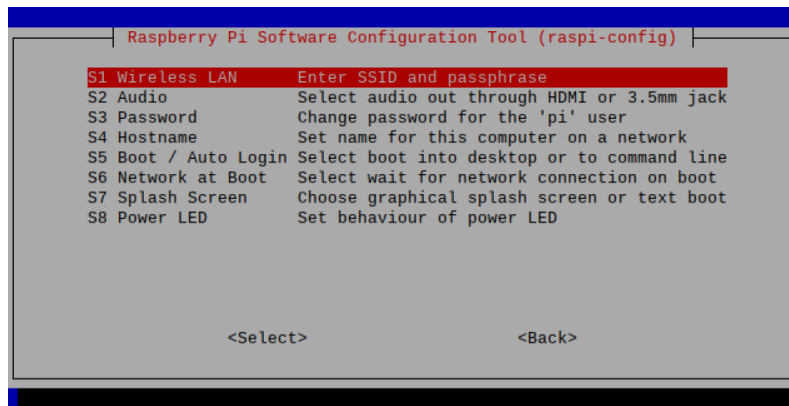

3. Press Enter and enter the WiFi name in the "Please enter SSID" interface.

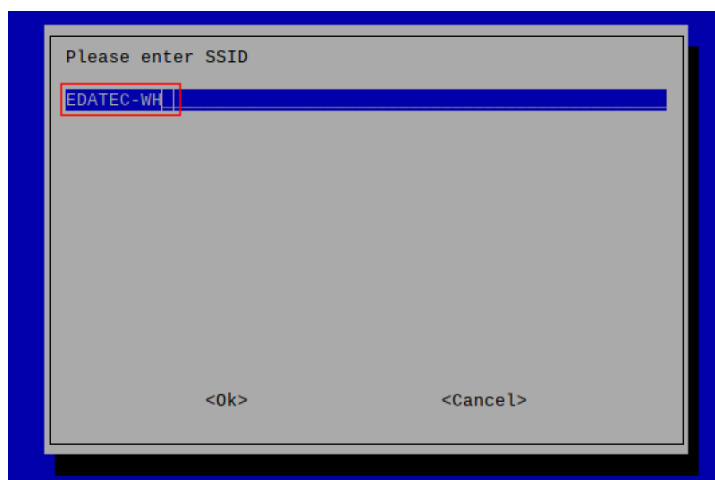

4. Press Enter to enter the WiFi password in the "Please enter passphrase. Leave it empty if none" interface.

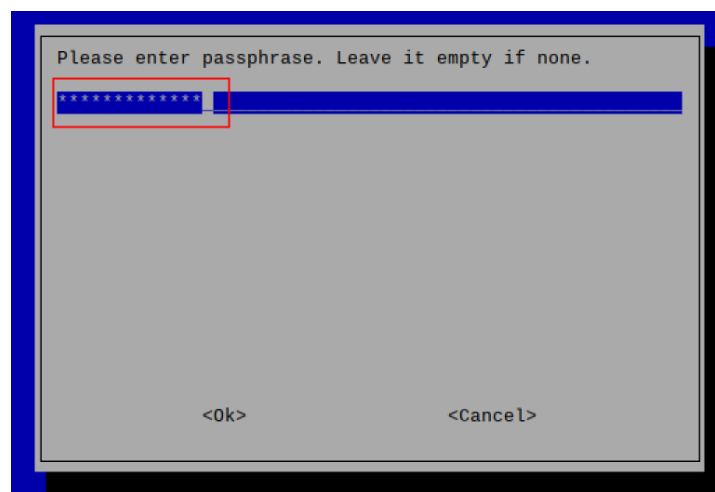

5. Press Enter to exit the main interface of the pane, select "Finish" and press Enter to complete the setting and return to the command line window.

5.6 Configuring Bluetooth (optional)

User can choose ED-IPC2100 with Bluetooth version, and the Bluetooth function is enabled by default, so relevant configuration is required before using Bluetooth.

5.6.1 Basic Configuration Command

Command	Function Description
<code>bluetoothctl scan on</code>	Enable Bluetooth scanning
<code>bluetoothctl scan off</code>	Disable Bluetooth scanning
<code>bluetoothctl discoverable on</code>	Enable Bluetooth discovery (which can be discovered by the other party)
<code>bluetoothctl discoverable off</code>	Disable Bluetooth discovery
<code>bluetoothctl trust <i>device_MAC</i></code>	Trust device
<code>bluetoothctl connect <i>device_MAC</i></code>	Connect device
<code>bluetoothctl disconnect <i>device_MAC</i></code>	Disconnect device

5.6.2 Configuration Example

This chapter introduces how to configure Bluetooth through a configuration example.

Preparation:

- Bluetooth scanning is enabled.
- Bluetooth discovery is enabled.

Steps:

1. Enter the Bluetooth view;

```
sudo bluetoothctl
```

2. Enable bluetooth.

```
power on
```

3. Scan Bluetooth device.

```
scan on
```

Returned display information:

```
Discovery started
```

```
[CHG] Controller B8:27:EB:85:04:8B Discovering: yes
[NEW] Device 4A:39:CF:30:B3:11 4A-39-CF-30-B3-11
```

4. Find the name of the turned-on Bluetooth device;

devices

Returned display information:

```
Device 6A:7F:60:69:8B:79 6A-7F-60-69-8B-79
```

```
Device 67:64:5A:A3:2C:A2 67-64-5A-A3-2C-A2
```

```
Device 56:6A:59:B0:1C:D1 Lefun
```

```
Device 34:12:F9:91:FF:68 test
```

5. Pairing target devices;

```
pair 34:12:F9:91:FF:68
```

```
34:12:F9:91:FF:68 is target device's device_MAC
```

Returned display information:

```
Attempting to pair with 34:12:F9:91:FF:68
```

```
[CHG] Device 34:12:F9:91:FF:68 ServicesResolved: yes
```

```
[CHG] Device 34:12:F9:91:FF:68 Paired: yes
```

```
Pairing successful
```

6. Add as trusted device

```
trust 34:12:F9:91:FF:68
```

```
34:12:F9:91:FF:68 is target device's device_MAC
```

Returned display information:

```
[CHG] Device 34:12:F9:91:FF:68 Trusted: yes
```

```
Changing 34:12:F9:91:FF:68 trust succeeded
```

5.7 Configuring 4G (Optional)

User can choose ED-IPC2100 with 4G version, which needs to be configured before using 4G network.



TIP:

ED-IPC2100 supports to configure network through Network Manager tool or dhcpcd tool

5.7.1 Use The NetworkManager Tool To Configure The Network

If you need to connect to a 4G network, you need to create a gsm network connection first. The following configuration is based on different scenarios.

5.7.1.1 Scenarios Without APN Configuration

If the user's 4G network does not need to be configured with APN, it can be configured according to the following steps.

Steps:

1. Customize a gsm network name, such as 4G1.
2. Execute the following command to create a gsm network named 4G-1.

```
sudo nmcli connection add type gsm con-name 4G1
```

```
pi@raspberrypi:~ $ sudo nmcli connection add type gsm con-name 4G1  
Connection '4G1' (cbf903af-bd5f-4039-a24c-d423c641558c) successfully added.
```

5.7.1.2 Scenarios With APN Configuration

If the user's 4G network needs to be configured with APN, it can be configured with reference to the following steps.

Steps:

1. Customize a gsm network name (for example, 4G2) and get the name of APN (for example, apn1).
2. Execute the following command to create a gsm network named 4G2.

```
sudo nmcli connection add type gsm con-name 4G2 ifname cdc-wdm0 gsm.apn apn1
```

```
pi@raspberrypi:~$ sudo nmcli connection add type gsm con-name 4G2 ifname cdc-wdm0 gsm.apn apn1
Connection '4G2' (df62b252-7db8-4547-adb0-f5456590bc76) successfully added.
```

5.7.1.3 Scenario Where Username And Password Need To Be Configured

If the user's 4G network needs to be configured with a username and password, you can refer to the following steps.

Steps:

1. Customize a gsm network name (for example, 4G3), and respectively obtain the number, name and password of the gsm network to be configured (for example, 777, mycdma, mobile).
2. Execute the following command to create a gsm network named 4G3.

```
sudo nmcli connection add type gsm con-name 4G3 ifname cdc-wdm0 ifname cdc-wdm0 gsm.number 777 gsm.username mycdma gsm.password mobile
```

```
pi@raspberrypi:~$ sudo nmcli connection add type gsm con-name 4G3 ifname cdc-wdm0 ifname cdc-wdm0 gsm.number 777 gsm.username mycdma gsm.password mobile
Connection '4G3' (e097bf5a-f44f-40ca-814e-4c66de9941ec) successfully added.
```

5.7.2 Configure The Network By Using The dhcpd Tool

By default, automatic dialing is prohibited in 4G networks. If users want to start automatic dialing and use the network, they need to enable "lte-reconnect.service" service. Configure as follows according to different scenarios requirements.

5.7.2.1 Scenarios Without APN Configuration

If the user's 4G network does not need to be configured with APN, it can be configured according to the following steps.

Steps:

1. Execute the following command to enable the "lte-reconnect.service" service.

```
sudo systemctl enable lte-reconnect.service
```

2. Execute the following command to start the "lte-reconnect.service" service and make automatic dialing.

```
sudo systemctl start lte-reconnect.service
```

3. Execute the following command to check the status of the wwan interface.

ifconfig

5.7.2.2 Scenarios With APN Configuration

If the user's 4G network needs to be configured with APN, it can be configured with reference to the following steps.

Steps:

1. Get the name of APN (for example, APN22).
2. Execute the following command to enable the "lte-reconnect.service" service.

sudo systemctl enable lte-reconnect.service

3. Execute the following command to start the "lte-reconnect.service" service and make automatic dialing.

sudo systemctl start lte-reconnect.service

4. Execute the following command to check the status of the wwan interface.

ifconfig

5. Execute the following command to open /usr/share/ed-ec20-qmi/lte-reconnect.sh file.

sudo nano /usr/share/ed-ec20-qmi/lte-reconnect.sh

6. Change the dialing command "\$BSP_HOME_PATH/quectel-CM -4 -f \$LOGFILE &" to "\$BSP_HOME_PATH/quectel-CM -4 -f \$LOGFILE -s apn22 &". Where "apn22" is the name of the obtained APN.
7. Use Ctrl+X to save the file and exit edit mode.
8. Execute the following command to restart the "lte-reconnect.service" service.

sudo systemctl restart lte-reconnect.service

5.7.3 Configure 4G Module Reset

When the device fails to recognize the SIM card, you can reset the 4G module through the command

line.

Steps:

1. Execute the following commands to detect and install gpiod tools.

sudo apt update

sudo apt install gpiod

2. Execute the following command to reset the 4G module.

gpioset -m time -s 1 2 3=0

Where 2 indicates gpiochip and 3 indicates that the controlled gpio pin is GPIO3.

5.8 Configuring Buzzer

The ED-IPC2100 contains a buzzer, which supports manually configure the buzzer to turn on and off.

1. Execute the following commands to detect and install gpiod tools.

```
sudo apt update
```

```
sudo apt install gpiod
```

2. Execute the following commands to check the number of gpiochip.

```
gpioinfo
```

In the result, the gpiochip of 16 lines is the gpiochip of the buzzer.

3. Execute the following command to turn on and turn off the buzzer.

- ◆ Turn on the buzzer:

```
gpioset 2 2=1
```

- ✓ The first 2 indicates the number of gpiochip queried in step 2.

- ✓ The second 2 indicates that the controlled gpio pin is GPIO2.

- ✓ 1 indicates the high level.

- ◆ Turn off the buzzer:

```
gpioset 2 2=0
```

- ✓ The first 2 indicates the number of gpiochip queried in step 2.

- ✓ The second 2 indicates that the controlled gpio pin is GPIO2.

- ✓ 0 indicates the low level.

5.9 Configuring RTC

ED-IPC2100 contains an integrated RTC, which automatically reads the system time synchronously by default, and can manually read and write the system time into RTC.

- ◆ Execute the following command to read the RTC time manually.

```
sudo hwclock -r
```

- ◆ Execute the following command to write the system time into RTC.

```
sudo hwclock -w
```

5.10 Configuring Serial Port

This chapter introduces the configuration method of RS232 and RS485.

5.10.1 Install picocom tool

In the Linux environment, you can use the picocom tool to debug the serial ports RS232 and RS485.

Execute the following command to install the picocom tool.

```
sudo apt-get install picocom
```

5.10.2 Configure RS232

Different product models correspond to different numbers of RS232 ports and different COM ports and device files, as shown in the following table:

Product Model	Number of RS232 Ports	Corresponding COM Port	Corresponding Device File
ED-IPC2110	2	COM1, COM3	/dev/com1, /dev/com3
ED-IPC2120	2	COM1, COM3	/dev/com1, /dev/com3
ED-IPC2130	1	COM1	/dev/com1
ED-IPC2140	0	/	/

Preparation:

The RS232 port of ED-IPC2100 has been connected with external device.

Steps:

1. Execute the following command to open the serial port com1, and configure the serial port baud rate to 115200.

```
picocom -b 115200 /dev/com1
```

2. Input commands as needed to control external device.

5.10.3 Configure RS485

Different product models correspond to different numbers of RS485 ports and different COM ports

and device files, as shown in the following table:

Product Model	Number of RS485 Ports	Corresponding COM Port	Corresponding Device File
ED-IPC2110	2	COM2, COM4	/dev/com2, /dev/com4
ED-IPC2120	2	COM2, COM4	/dev/com2, /dev/com4
ED-IPC2130	3	COM2, COM3, COM4	/dev/com2, /dev/com3, /dev/com4
ED-IPC2140	4	COM1, COM2, COM3, COM4	/dev/com1, /dev/com2, /dev/com3, /dev/com4

Preparation:

The RS485 port of ED-IPC2100 has been connected with external devices.

Steps:

1. Execute the following command to open the serial port com4, and configure the serial port baud rate to 115200.

```
picocom -b 115200 /dev/com4
```

2. Input commands as needed to control external devices.

5.11 Configuring Audio (Optional)



ED-IPC2100 contains one audio input (supports access to MIC) and one extended speaker output. The volume of Master, MIC and Speaker can be adjusted, and support recording.

5.11.1 Adjust The Volume

It supports manual adjustment of MIC, Speaker and Master volume.

- ◆ If you are using the Desktop version of the operation system, you can adjust the volume of the MIC and Master directly through the desktop icon.

Steps:

1. Click the icon  or  in the upper right corner of the desktop to open the volume adjustment column.



2. Drag the button of the volume adjustment column up and down to adjust the volume, check or uncheck the Mute check box to mute and unmute the audio.

- ◆ Both Desktop and Lite versions of the operation system support opening the volume adjustment interface through the command line to adjust the volume.

Steps:

1. Execute the following command to open the volume adjustment interface.

alsamixer

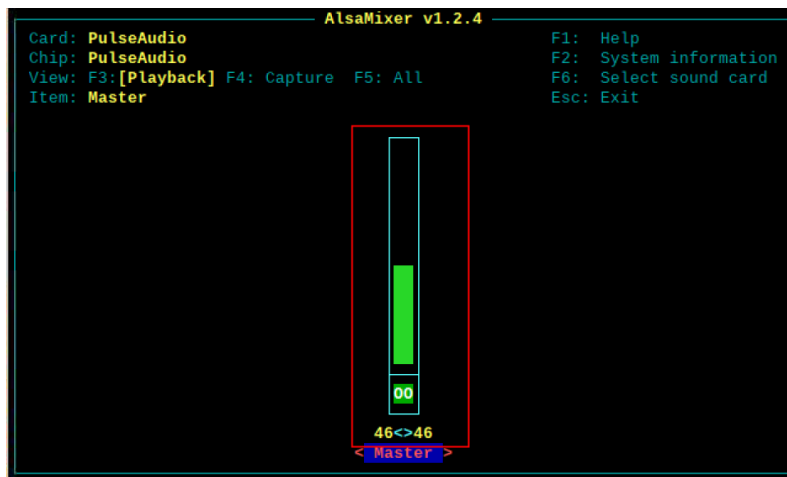

- View the volume value of the current Master in the opened interface. You can adjust the volume through the **↑** key and **↓** key on the keyboard, and press the M key to mute and unmute the audio.

Keyboard Key	Function
↑	Volume+
↓	Volume-
M	Mute or Unmute

- Press F6 to open "Sound Card" interface, select "2 USB Advanced Audio Device".

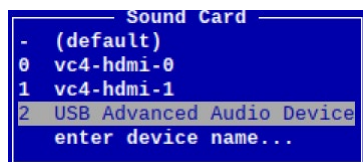

- Press Enter to open the volume interface of MIC and Speaker, and you can adjust the volume of MIC and Speaker respectively through the **↑** key and **↓** key on the keyboard, and press M to mute and unmute MIC/Speaker.

Keyboard Key	Function
↑	Volume+
↓	Volume-
M	Mute or Unmute

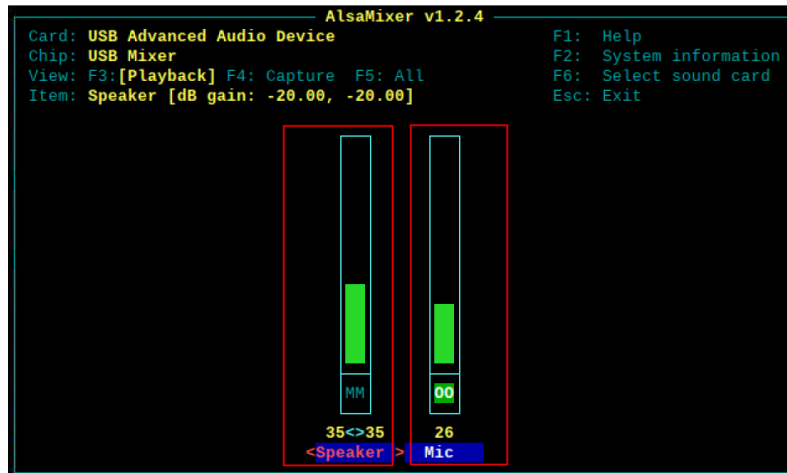

5.11.2 Configure Record

It supports the audio recording of MIC input.

Preparation:

The audio interface has been connected to MIC.

Steps:

1. Execute the following command to open the volume adjustment interface.

```
alsamixer
```

2. Press F6 to open the "Sound Card" interface, select "2 USB Advanced Audio Device", and press Enter to open the volume adjustment interface of MIC and Speaker to ensure that MIC is not muted.
3. Press Esc to exit to the command pane, execute the following command to start recording audio named test1.wav, as shown in the figure below.

```
arecord -fcd -Dhw:2 -c 1 --vumeter=mono test1.wav | aplay -fcd -Dhw:2
```

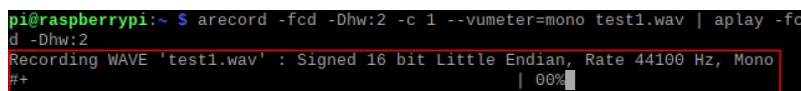

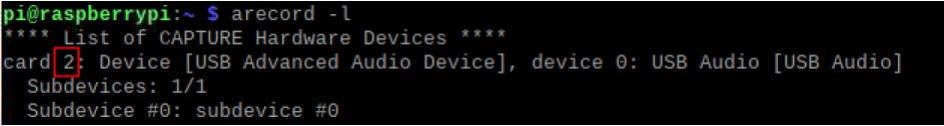
Parameters	Description
cd	Indicates the audio format, which can be set to cd, cdr, dat and other formats, and can be set as needed.
2	Indicates the sound card for recording, it needs to be obtained by executing arecord -l before recording, as shown in the following figure: 
test1.wav	Indicates the recorded file name, which can be customized by the user.

4. Use Ctrl+C to close recording.
5. Execute the following command to obtain the storage path of the recording file.

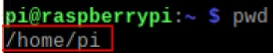
pwd

```
pi@raspberrypi:~ $ pwd
/home/pi
```

5.12 Configuring USER Indicator

ED-IPC2100 contains a USER indicator, and users can customize the status according to actual needs.

1. Execute the following commands to detect and install gpiod tools.

sudo apt update

sudo apt install gpiod

2. Execute the following command to turn on and turn off the USER indicator.

- ◆ Turn on the USER indicator:

gpioset -m time -s 1 2 5=0

- ✓ 2 indicates the number of gpiochip.
- ✓ 5 indicates that the controlled gpio pin is GPIO5.
- ✓ 0 indicates the high level.

- ◆ Turn off the USER indicator:

gpioset -m time -s 1 2 5=1

- ✓ 2 indicates the number of gpiochip.
- ✓ 5 indicates that the controlled gpio pin is GPIO5.
- ✓ 1 indicates the low level.