

U_Project_Information
Project_Information.SchDoc

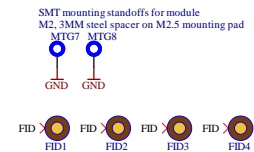

Title DD2090 4CAM FFC			Luxonis Holding 1925 Harmony Park Drive Westminster, CO 80254 United States	
Size: Tabloid	Number: D0000190	Revision: R7M1E7		
Date: 18/05/2023	Time: 17:42:26	Sheet 1 of 12		
Drawn by: <i>Dan Dunga</i>				



Project: DD2090 4CAM FFC
Current Revision: R7M1E7
Assembly variant: Production_BMO085

DD2090 4CAM FFC Revision History:

Date	Revision	Reason for Change	Changes Implemented
10 June 2021	DM1099FFC R1M0E1-> DD2090 4CAM FFC R0M0E0	1) Changed SoM to BW2099 2) Added MIPI CAM D (4 lane) 3) Added uSD card 4) Added Software controll over FSIN signal between the 2 lane and 4 lane cameras (US) 5) Added ESD protection on USB signals	
	R0M0E0 -> R1M1E1	1) Corrected SoM footprint (mounting posts error) 2) BOOT should be connected to BOOT2 and BOOT4 for USB recovery 3) Updated assembly variant to default NOR boot mode	1) Increase the board from 62x38mm to 65x38mm 2) Added EEPROM
29 Dec 2021	R1M1E1 -> R2M1E2	1) Change the 3.3V power supply to 2A capability 2) Increase silkscreen size and position for the connector markings to be more visible when assembled 3) Change USBC switch 4) Connecte BNO068 WAKE signal to MX 5) Update PRBS connector adding Strobe and 4-Lane FSYNC	1) Change the 3.3V power supply to 3A capability (should be enough for any kind of CCM) 2) Increased silkscreen size and updated position for the connector markings 3) Changed USBC switch with NXP alternative 4) Connected WAKE signal to MXIO10 5) Updated PSRBS connector adding Strobe and 4-Lane FSYNC
15 Apr 2022	R2M1E2 -> R3M1E3	1) Correct issue on the swapped silkscreen (QSPI and AUX) 2) Remove IMU BNO068 from BOM due to shortage and add BMI270	1) Correct issue on the swapped silkscreen (QSPI and AUX) 2) Remove IMU BNO068 from BOM added BMI270
15 Apr 2022	R3M1E3 -> R4M1E4	1) Add additional 0R resistor which will short BOOT_SEL with BOOT_AUX for KB recovery mode 2) Add GND vias on 3V3 regulator	1) Added additional 0R resistor which will short BOOT_SEL with BOOT_AUX for KB recovery mode 2) Added GND vias on 3V3 regulator
8 Sep 2022	R4M1E4 -> R5M1E5	1) Add additional FFC connector for active illumination (dot projector, IR LED)	1) Added additional FFC connector for active illumination (dot projector, IR LED)
16 Nov 2022	R5M1E5 -> R6M1E6	1) Barrel jack ideal diode cut off when illumination module was attached 2) Some pins are not supported on KB 3) Unnecessary componens on 5V power LED 4) SW external reset needed for KB	1) Replaced ideal diode with mosfet 2) - FSIN_MODE_SELECT moved to MXIO_38 - WAKE moved to MXIO_39 - AUX_IO_IRQ moved to MXIO_11 3) Removed mosfet and wired the LED directly 4) Connected GPIO to reset pin
8 Sep 2022	R6M1E6 -> R7M1E7	1) FSYNC needs to be enabled (connected together by default)	1) Enabled the swith by default with additional resistor (R44)

VDD_5V drawn by BW2099 can be up to 1A
 VBUS on BW2099 is only sense input

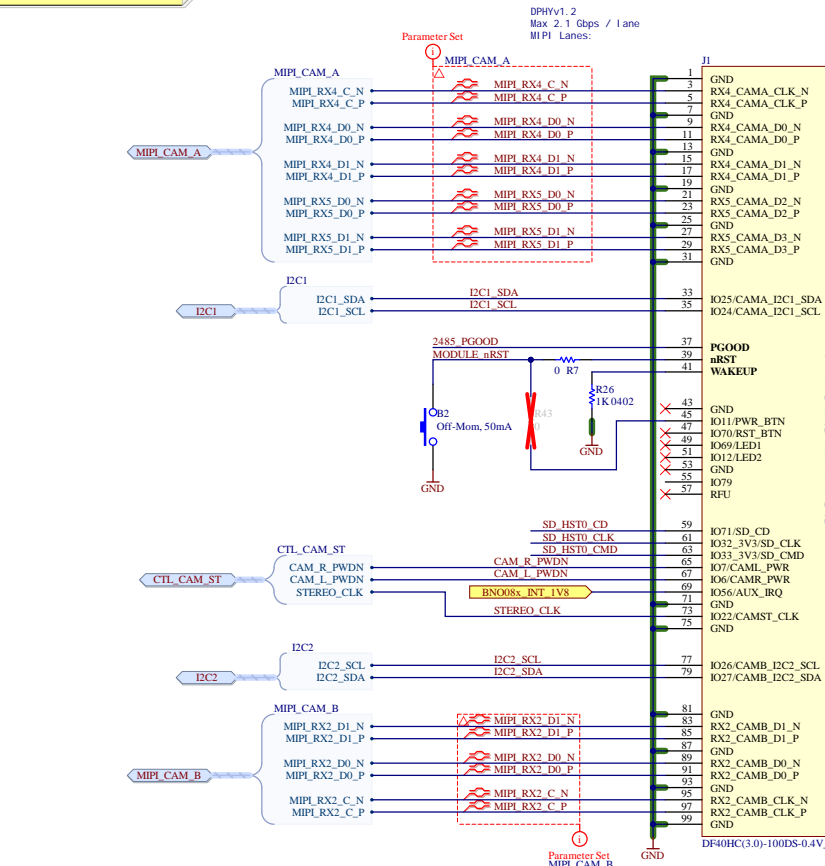
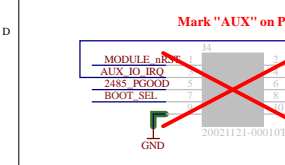
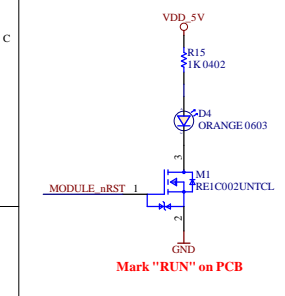
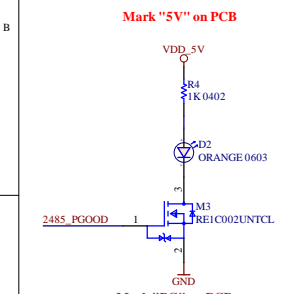
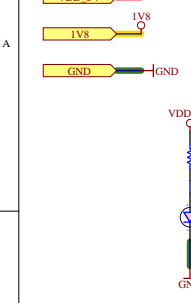

CONNECTOR A

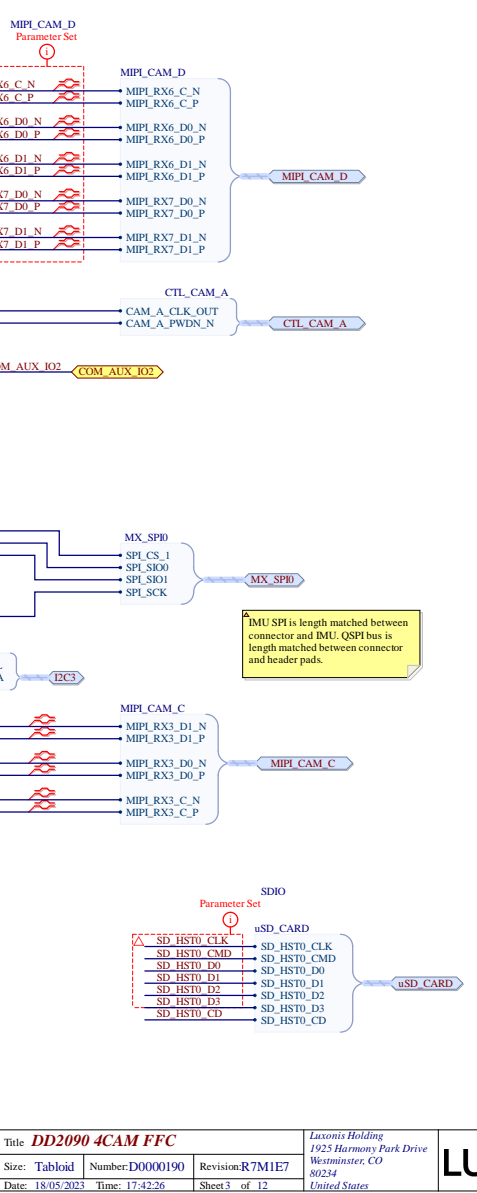
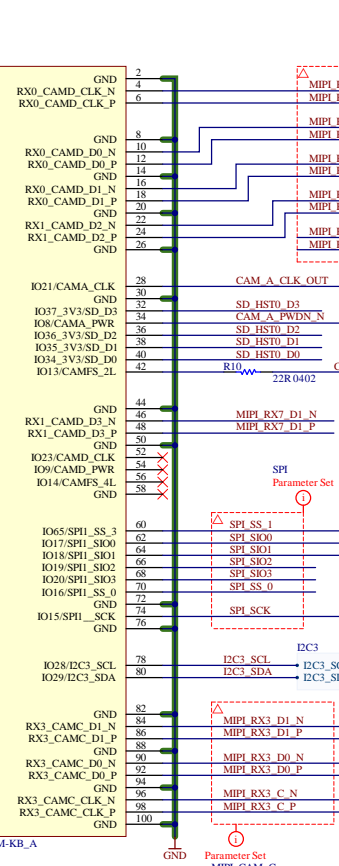
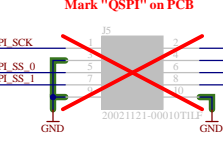
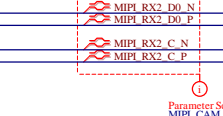
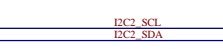
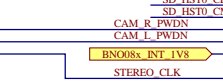
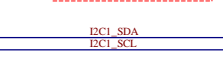
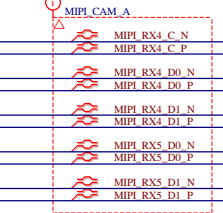
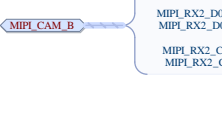
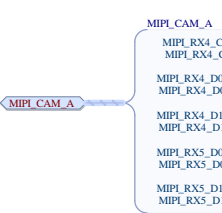

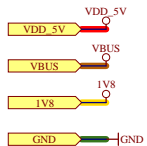

VDD_5V drawn by BW2099 can be up to 1A
 VBUS on BW2099 is only sense input

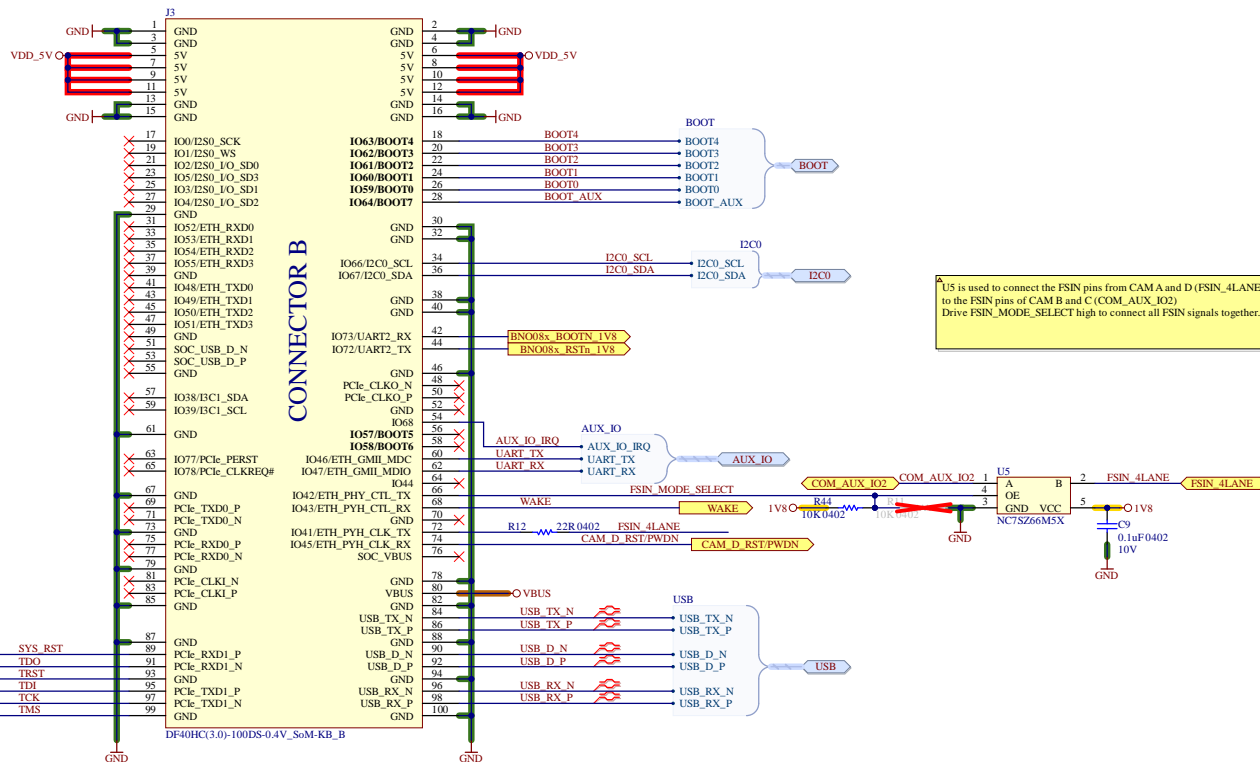

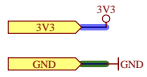

STEREO CAMERA PAIR

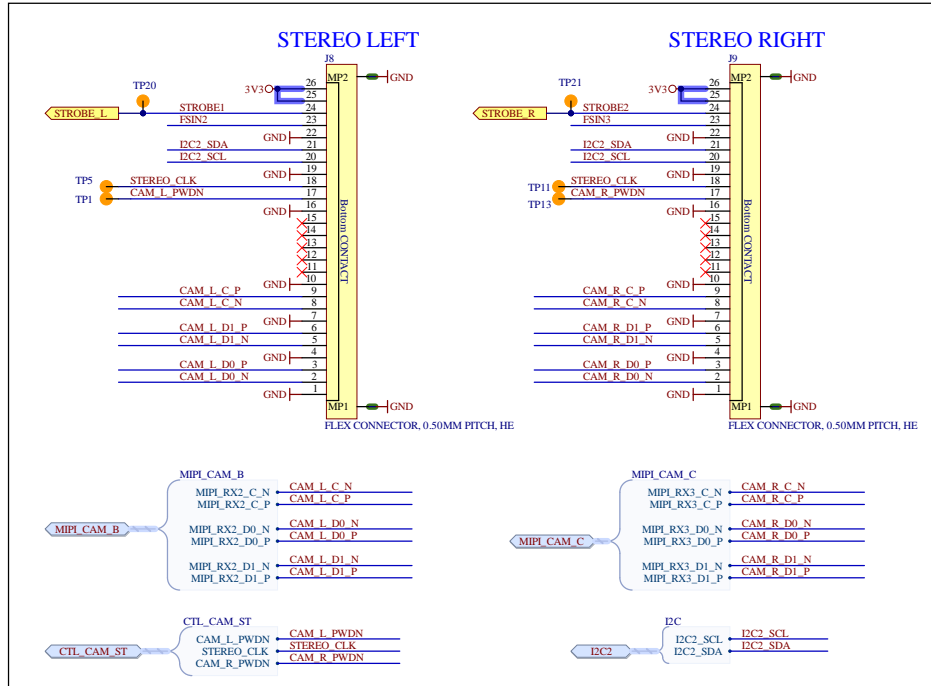

ESD PROTECTION

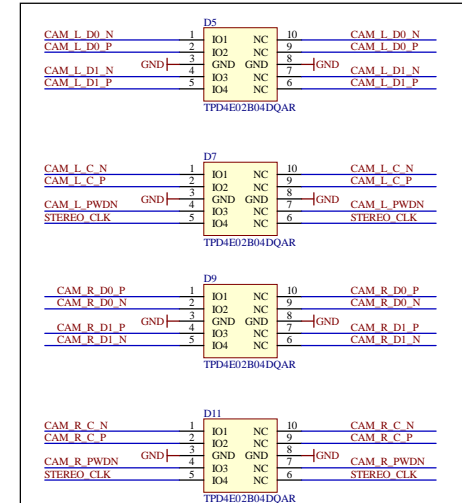

RGB CAMERA 1

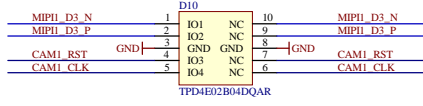
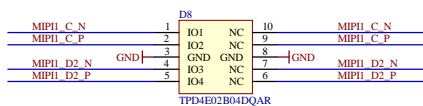
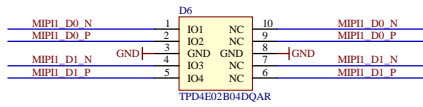
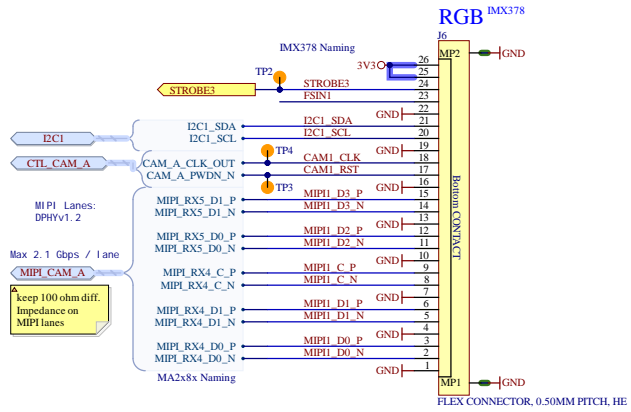
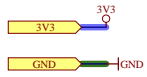

ESD PROTECTION

RGB CAMERA 2

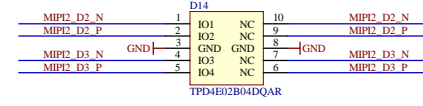
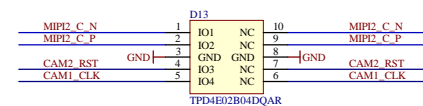
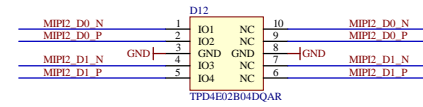
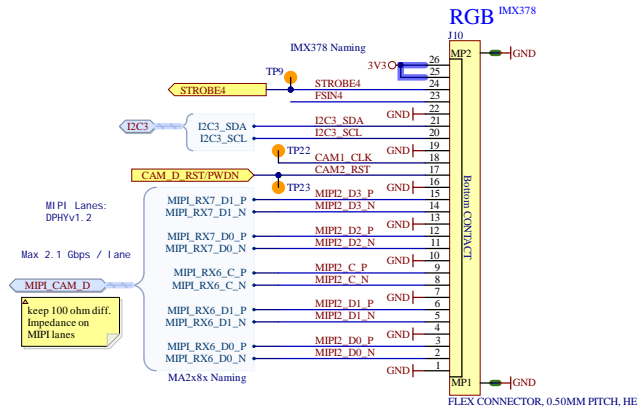

ESD PROTECTION



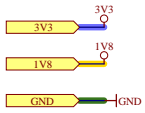

JTAG

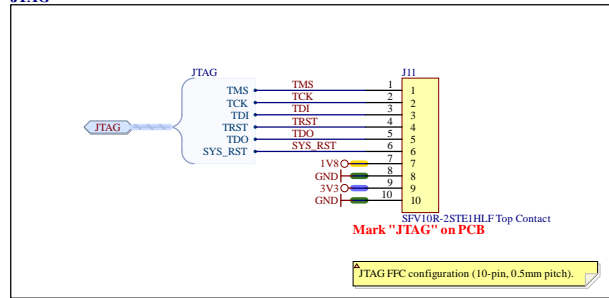

3.3V GPIO (uSD)

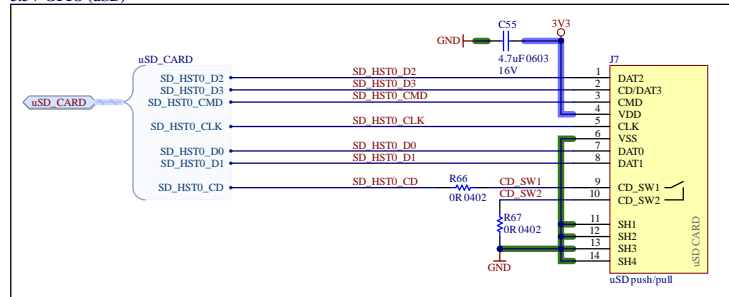

BOOT MODES

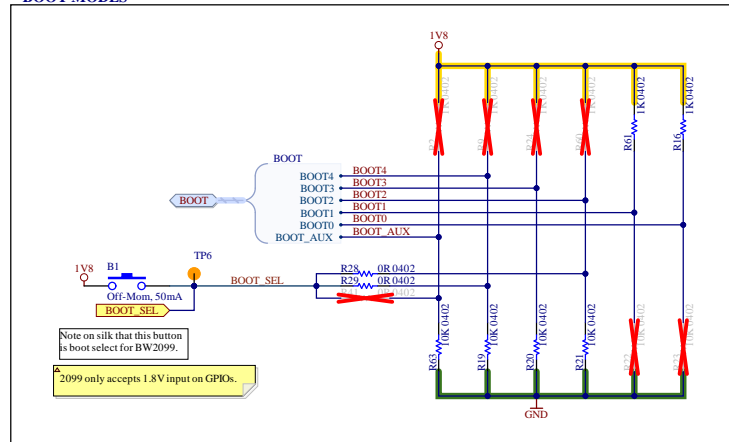

Title DD2090 4CAM FFC			Luxonis Holding 1925 Harmony Park Drive Westminster, CO 80234 United States	
Size: Tabloid	Number: D0000190	Revision: R7M1E7		
Date: 18/05/2023	Time: 17:42:27	Sheet 7 of 12		
Drawn by: Dan Dunga			LUX enjis	

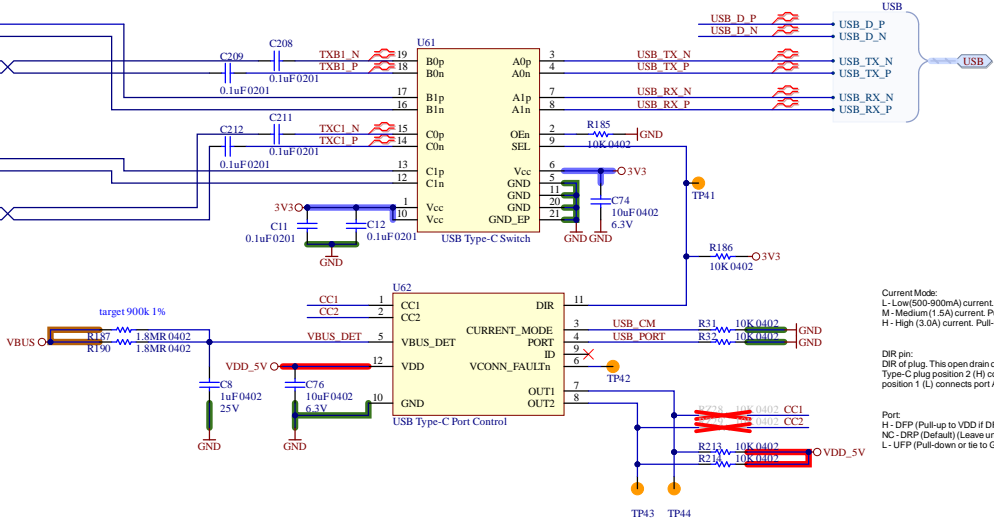
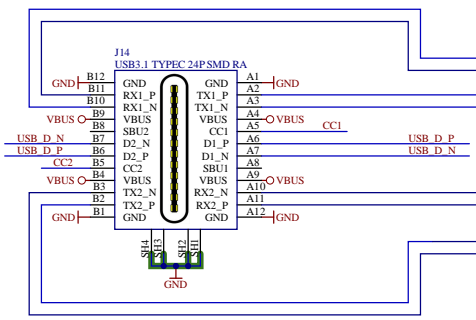
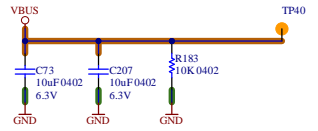
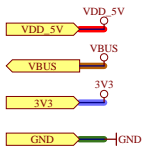

ESD PROTECTION

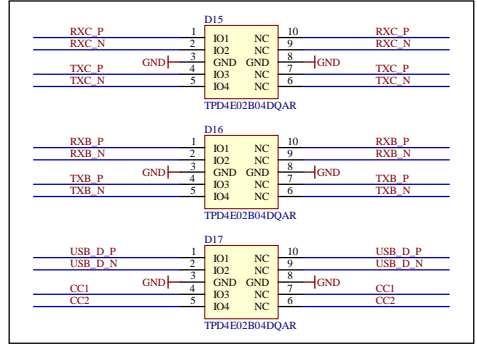

Current Mode:
 L- Low(500-900mA) current. (Default) Pull-down to GND or leave unconnected.
 M- Medium(1.5A) current. Pull-up to VDD with 500-kΩ resistor.
 H- High(3.0A) current. Pull-up to VDD with 10-kΩ resistor.

DIR pin:
 DIR of plug. This open drain output indicates the detected plug orientation:
 Type-C plug position 2 (H) connects Port A to Port C on U61. Type-C plug position 1 (L) connects port A to Port B on U61.

Port:
 H- DFP (Pull-up to VDD if DFP mode is desired)
 NC- DRP (Default) Leave unconnected if DRP mode is desired)
 L- UFP (Pull-down or tie to GND if UFP mode is desired)

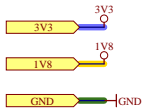

* For the switching sequence of power supply VDD and VDDIO it is mandatory that VDD is powered on and driven to the specified level before or at the same time as VDDIO is powered ON. Otherwise there are no limitations on the voltage levels of both pins relative to each other as long as they are used within the specified operating range.

VDD can be powered from 2.4V - 3.6V
VDDIO can be powered from 1.7V - 3.6V

NRST is the reset line for the BNO08X and can be either driven by the application processor or the board reset.

The H_INTN pin is the application interrupt line that indicates the BNO08X requires attention. This should be tied to a GPIO with wake capability. The interrupt is active low. On the BNO085, if the host fails to respond to the assertion of H_INTN within approximately 10 ms, the BNO085 will timeout, deassert H_INTN and retry the operation.

Pin 5 (PS1) and Pin 6 (PS0/WAKE) are the host interface protocol selection pins. For SPI selection, both pins must be high (from before reset until after the first assertion of H_INTN to select the SPI interface. Pin 5 may be tied to VDDIO. Pin 6 must be connected to a GPIO so that the WAKE functionality can be performed.

After reset the PS0/WAKE signal is used as a 'wake' signal taking the BNO08X out of sleep if the host wants to initiate communication with the BNO08X.

The BNO08X supports environmental sensors (e.g. pressure sensors, ambient light sensors) on a secondary I2C interface. This interface should be pulled up via resistors regardless of the presence of the external sensor as the SW polls for sensors at reset.

* BNO08x_BOOTN_1V8 is sampled at reset. If low, the BNO08x will enter bootloader mode.
* BNO08x_BOOTN_1V8 should be pulled high through a 10kR. To use the device firmware update (DFU) capability, it's recommended to connect Pin 4 to a GPIO pin on the external uC.

CLKSEL0 = 0 selects external XTAL. Pin has internal pull down, but is connected to GND explicitly.

The BNO08X can operate from an internal oscillator, an external 32.768 kHz clock or an external 32.768 kHz crystal. Hillcrest recommends a tolerance of 50ppm. If a crystal is used it must be connected across pins 26 and 27. Hillcrest recommends using a crystal with tolerance 50ppm with 12.5pF capacitor loading.

H_I2C ADDR:
SA0 = 0 = 0x4A (default)
SA0 = 1 = 0x4B
BOOT MODE I2C:
SA0 = 0 = 0x2N (default)
SA0 = 1 = 0x49

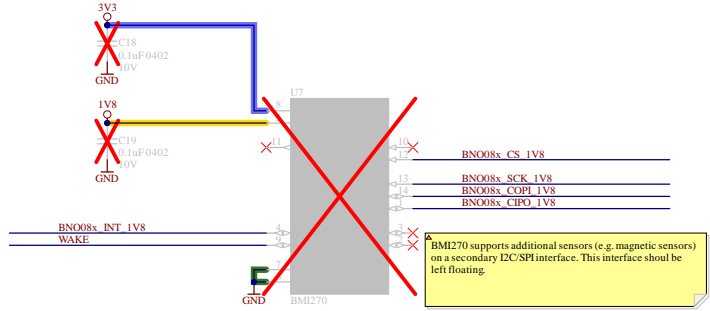
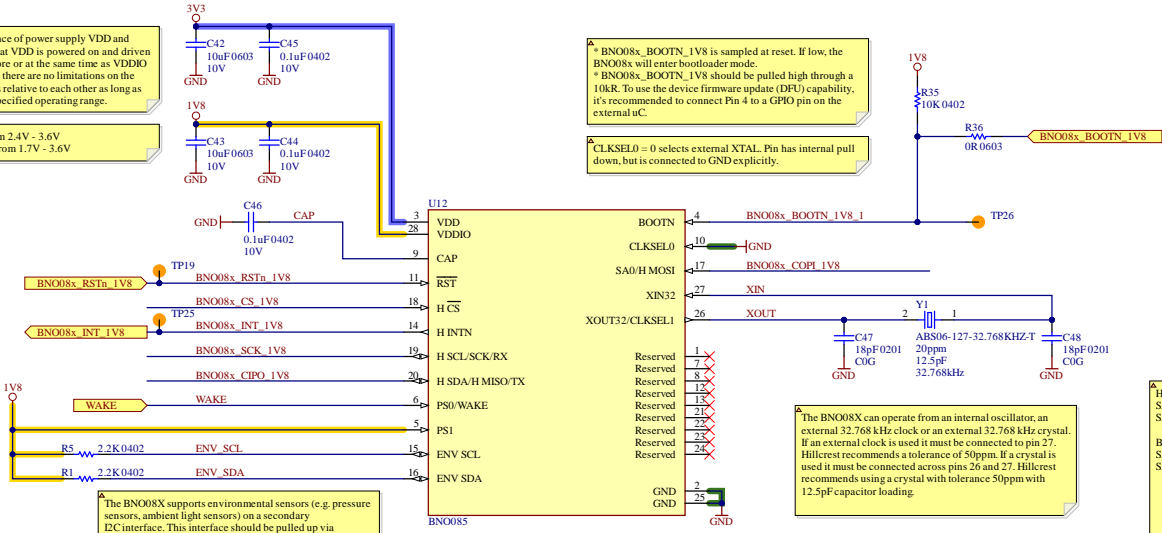

BM1270 supports additional sensors (e.g. magnetic sensors) on a secondary I2C/SPI interface. This interface should be left floating.

Sensor Orientation (gravity vector ↓)						
Output Signal X	0g / 0 LSB	1g / 8192 LSB	0g / 0 LSB	-1g / -8192 LSB	0g / 0 LSB	0g / 0 LSB
Output Signal Y	-1g / -8192 LSB	0g / 0 LSB	1g / 8192 LSB	0g / 0 LSB	0g / 0 LSB	0g / 0 LSB
Output Signal Z	0g / 0 LSB	0g / 0 LSB	0g / 0 LSB	0g / 0 LSB	1g / 8192 LSB	-1g / -8192 LSB

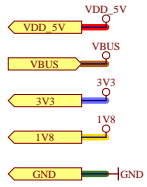

POWER INPUT - DIODE OR

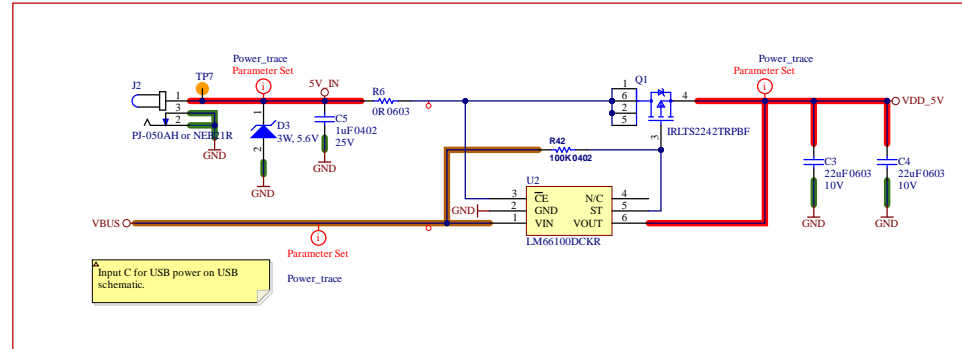

POWER REGULATION

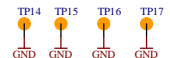
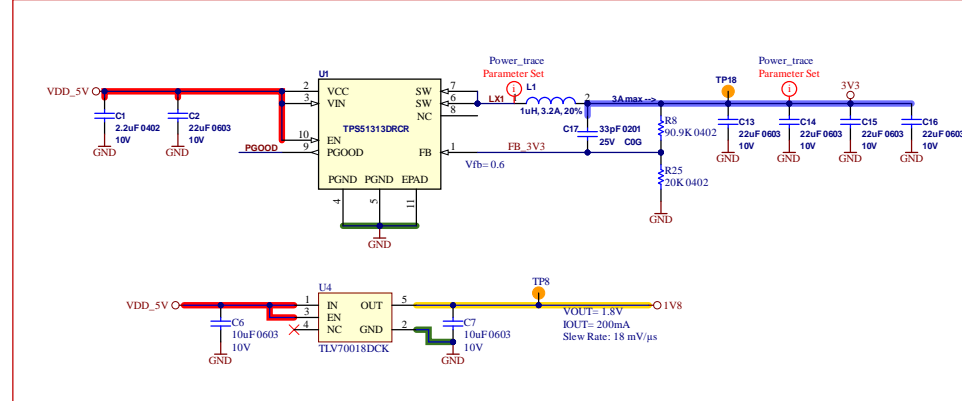

Title DD2090 4CAM FFC			Luxonis Holding 1925 Harmony Park Drive Westminster, CO 80254 United States	
Size: Tabloid	Number: D0000190	Revision: R7M1E7		
Date: 18/05/2023	Time: 17:42:27	Sheet 10 of 12		
Drawn by: <i>David Malovrh</i>			LUX on s	

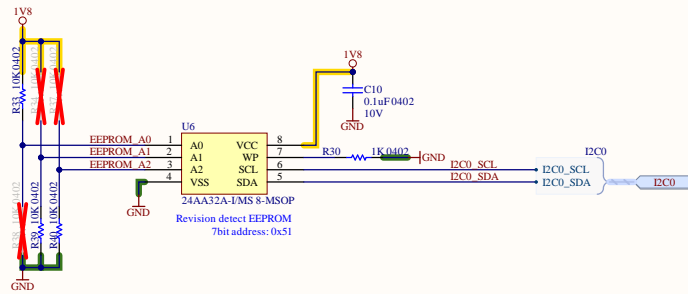
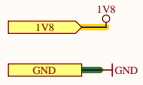

Title DD2090 4CAM FFC			Luxonis Holding 1925 Harmony Park Drive Westminster, CO 80234 United States		Cannot open file C:\Users\Brian.Luxonis\...
Size: Tabloid	Number: D0000190	Revision:			
Date: 18/05/2023	Time: 17:42:27	Sheet 11 of 12			
Drawn by: Dan Dunga					

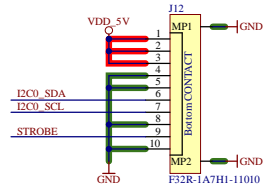
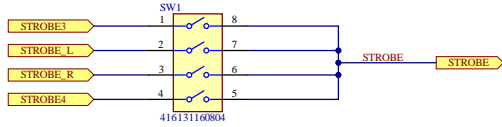
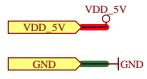

Title DD2090 4CAM FFC			Luxonis Holding 1925 Harmony Park Drive Westminster, CO 80234 United States	
Size: Tabloid	Number: D0000190	Revision: R7M1E7		
Date: 18/05/2023	Time: 17:42:27	Sheet 12 of 12		
Drawn by: <i>David Malovrh</i>				

