



PRODUCT INFORMATION

BUILD INSTRUCTIONS
CHECKING YOUR PCB & FAULT-FINDING
MECHANICAL DETAILS
HOW THE KIT WORKS

CREATE YOUR OWN WIRELESS SPEAKER WITH THIS

BLUETOOTH AMPLIFIER KIT

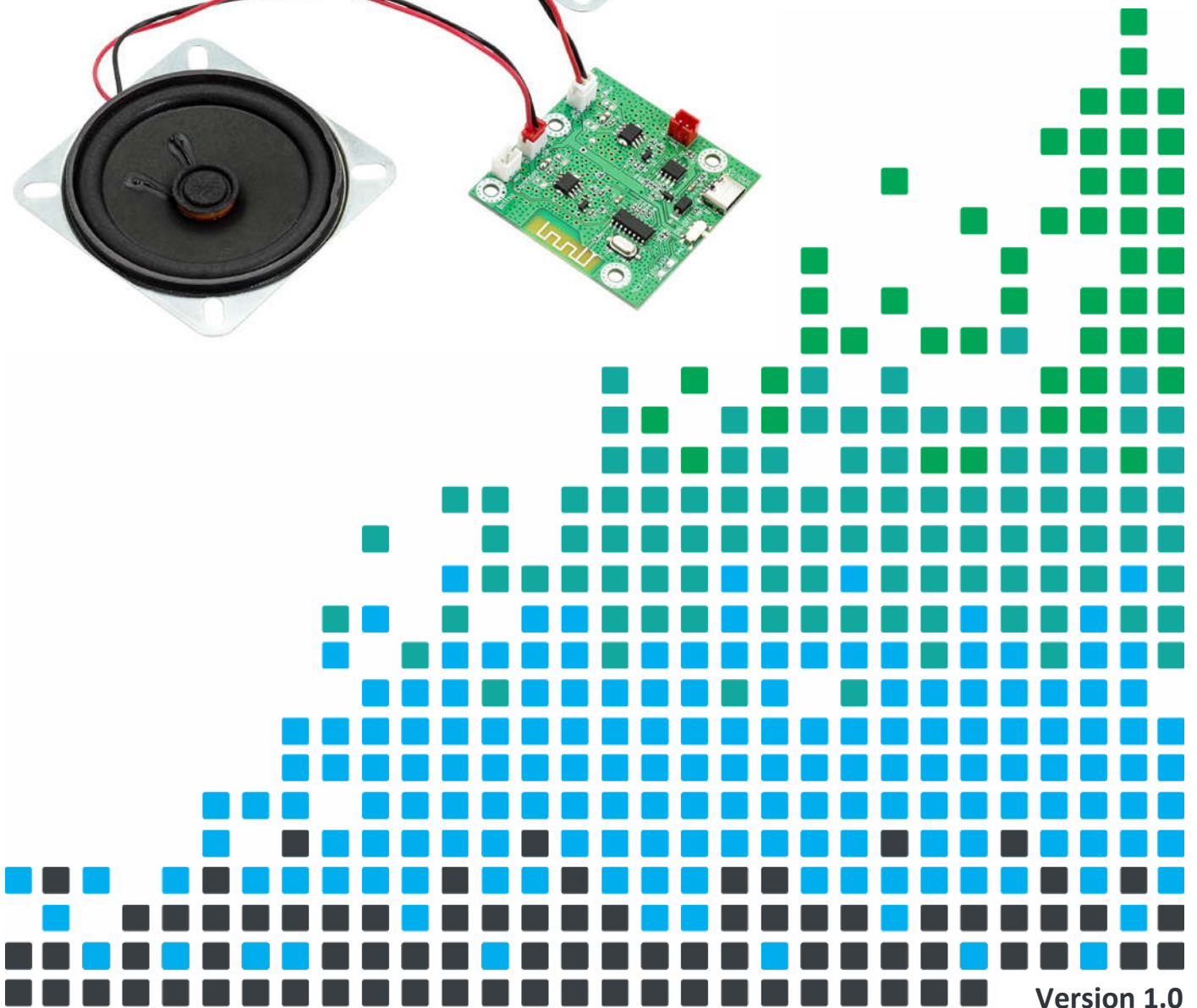

Index of Sheets

PRODUCT INFORMATION

- Index of Sheets
- Main Features
- Power Specification
- PCB Features
- Operating Instructions
- Pairing Process
- Designing the Enclosure
- How the Bluetooth Amplifier Works
- Online Information

Main Features

- 2 x 3W audio amplifier with Bluetooth link.
- Supports 4Ω speakers.
- Play music from a phone, tablet or computer wirelessly.
- Simple user interface, via single on / off switch.
- Auto reconnects to last device on power up unless it can't be found when it enters pairing mode.
- LED and sounds indicate status information such as 'pairing'.
- Pauses music when the phone rings and diverts audio back to the handset (subject to compatible phone).
- Operates from a 1A USB-C supply or LiPo battery (both available separately).
- Includes automatic LiPo battery charging for all battery capacities.
- Automatic power switch over between PSU and battery (when battery present).
- 7 hours continuous operation from a 1000mAh battery at 50% volume.
- Speakers supplied unconnected allowing cable routing to be personalised to specific enclosure designs; easy-to-use JST connectors for when the routing has been decided.



Bluetooth Amplifier

www.kitronik.co.uk/2182



Power Specification

Operating Voltage (USB supply)	4.5V – 5.5V
Operating voltage (LiPo battery)	3.2V – 4.2V
Nominal Current in standby mode	40 mA
Nominal Current 50% volume	140 mA
Nominal Current max volume	410 mA

Note: USB power supply. It is important to use a high quality USB-C power supply that can deliver a minimum of 1A while also providing a stable 5V supply. If this is not the case 'clipping' or 'cutting out' may be experienced when used at high volumes.

PCB Features

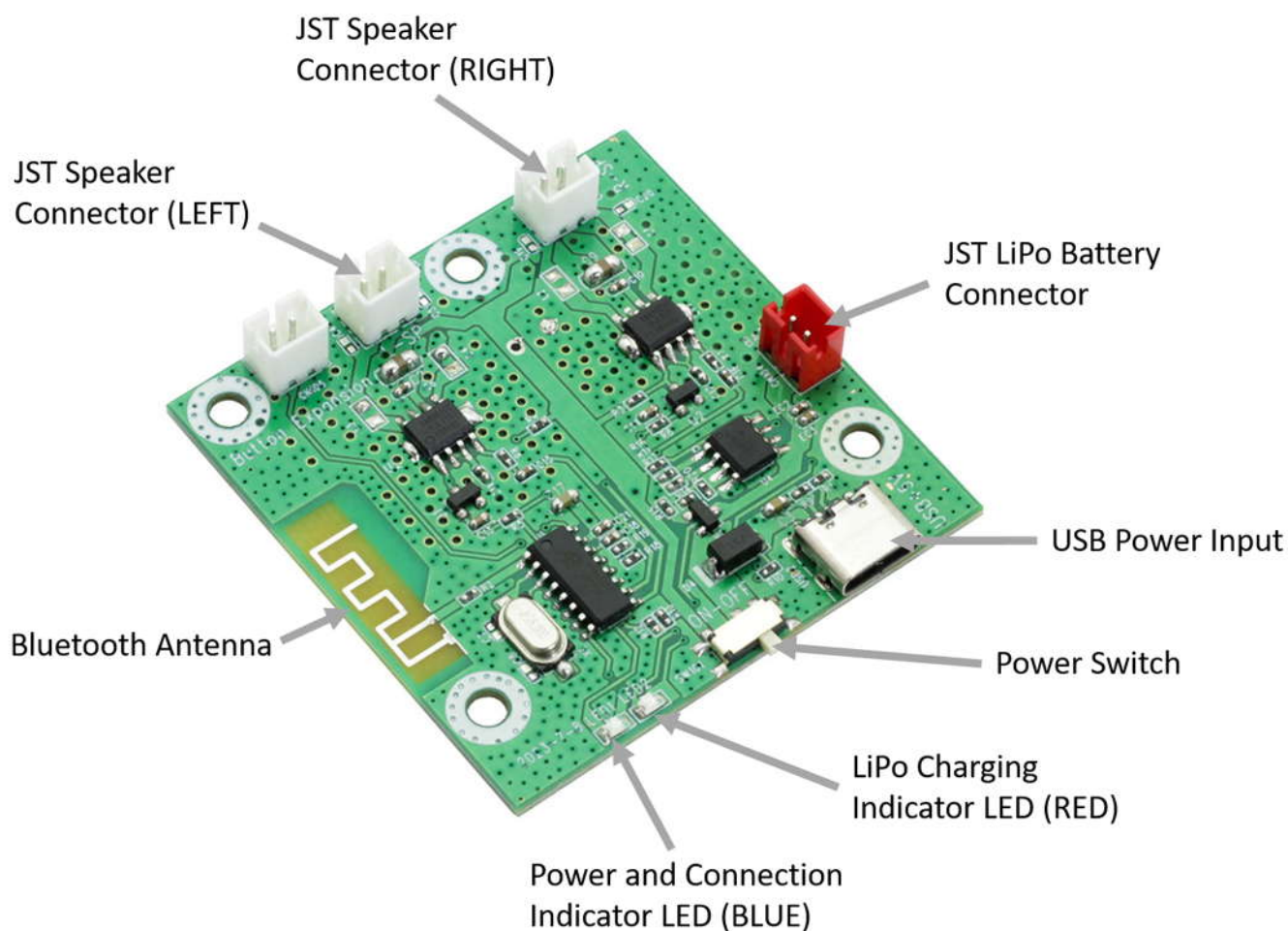

Operating Instructions

What is the LED indicating?

LED Colours & Flashes	Meaning
Blue LED, continuously on	Connected.
Blue LED, 1 flash every second	In pairing mode, waiting for a phone to connect.
Red LED, battery connected	Battery charging.
No Red LED, battery connected	Battery is fully charged, charging automatically stops.
No LEDs	Device not powered on.

What do the beeps indicate?

Sound	Meaning
Ascending sequences of tones	Device powered on.
Four identical tones	A new device has been successfully paired.
Single tone	Device connection lost, re-enters pairing mode.
Multiple high-pitched beeps	The battery is running low. Plug into the USB port.
Descending sequences of tones	Device auto-powering off.

Pairing Process

To pair the Bluetooth Amplifier to a device (provided it is not already paired), use the devices Bluetooth settings menu to search for new Bluetooth devices. The Bluetooth Amplifier will appear as 'R001' on phones, or 'Headphones R001 Stereo' / 'Headset (R001 Hands-Free AG Audio)' on laptops and computers.

To change to another device the current device requires disconnecting. Again this is done from the devices Bluetooth settings. Once complete the Bluetooth Amp automatically enters pairing mode again.

If the Bluetooth Amplifier is powered down and back up it will automatically connect to any Bluetooth device previously paired to which is in range. If there are none in range, it will automatically enter pairing mode.



Designing the Enclosure

When you design the enclosure, you will need to consider:

- The size of the PCB (right).
- How to mount the speaker (below).
- Where the power switch, USB connector and LED will be located.

These technical drawings of the amplifier PCB and speakers should help you to plan this.

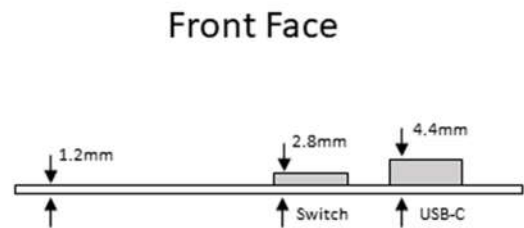
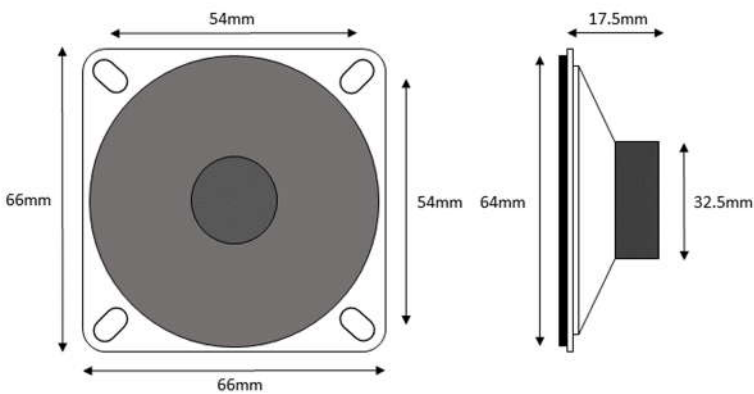
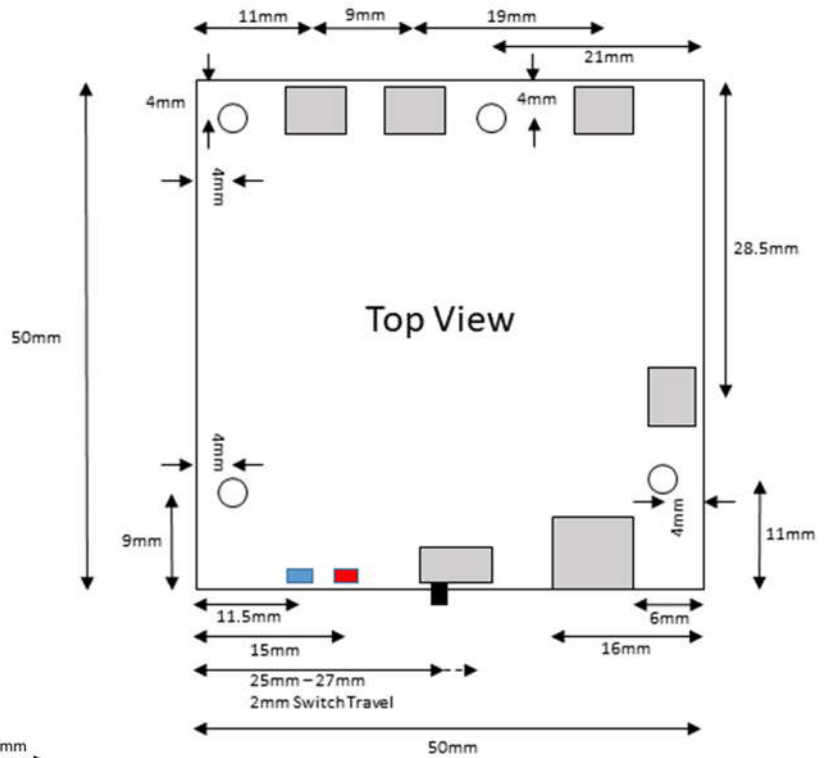

Mounting the PCB to the enclosure	
	<p>The drawing to the left shows how a hex spacer can be used with two bolts to fix the PCB to the enclosure.</p> <p>Your PCB has four mounting holes designed to take M3 bolts.</p>



How the Bluetooth Amplifier Works

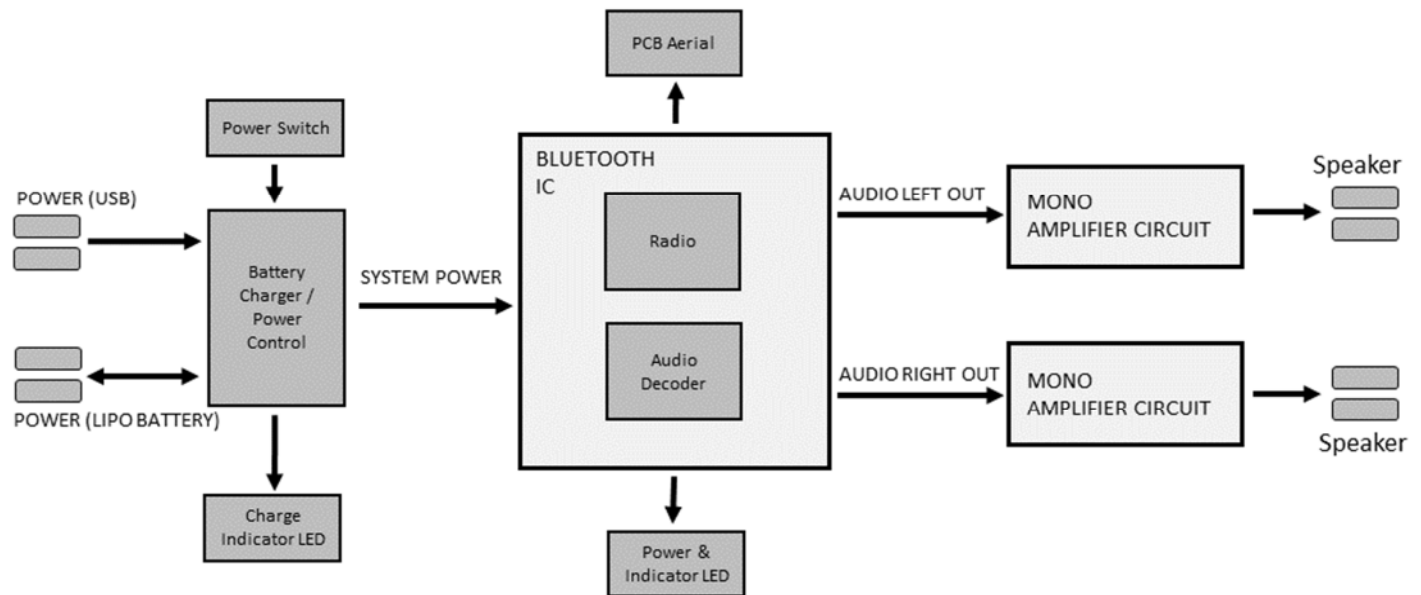

Bluetooth IC

At the heart of the Bluetooth Amplifier PCB is a Bluetooth Radio IC. This performs a number of tasks:

- Provides and manages the Bluetooth radio connection via the connected PCB aerial.
- Decodes the audio signal from the radio connection and outputs this to the amplifier circuits.
- Drives the (Power) Indicator LED that is used to display the current mode, such as 'pairing'.

Amplifier

The audio output from the Bluetooth IC is fed into two amplifier circuits (one for each channel). The output of these amplifier circuits is then fed into the speakers.

Each amplifier circuit is setup to have a fixed gain (or amplification) and the output volume is controlled by the Bluetooth IC. This is adjusted by altering the volume on the Bluetooth device to which it is connected.

Power

The circuit can be powered from either (or both) a USB-C power supply or LiPo battery. The power switch turns the power to the whole circuit fully off. This therefore needs to be in the 'on' for the battery to charge.

The LiPo charging circuit is provided by an IC that has specifically been designed to do this task. This IC drives an LED that indicates the charging state of the attached battery (red charging, off when fully charged).



Online Information

A copy of this product information is available to download from:

<http://www.kitronik.co.uk/2182>

Telephone +44 (0) 115 970 4243

Sales email: sales@kitronik.co.uk

Tech Support email: support@kitronik.co.uk

Web: www.kitronik.co.uk



kitronik.co.uk/twitter



kitronik.co.uk/facebook



kitronik.co.uk/youtube



kitronik.co.uk/instagram



Designed & manufactured
in the UK by 



Every effort has been made to ensure that these notes are correct, however Kitronik accept no responsibility for issues arising from errors / omissions in the notes.

© Kitronik Ltd - Any unauthorised copying / duplication of this booklet or part thereof for purposes except for use with Kitronik project kits is not allowed without Kitronik's prior consent.

