

LDROBOT

Move Smarter

LiDAR Sensor STL-19P

Datasheet



COPYRIGHT©2023 SHENZHEN LDROBOT CO.,LTD

深圳乐动机器人股份有限公司
SHENZHEN LDROBOT CO.,LTD

目录

1.	Product Description	1
2.	Product Features	1
3.	Introduction to Functions.....	2
	3.1. 360° scanning for ranging	2
	3.2. PWM speed control	2
	3.3. Glass detection	2
4.	Technical Parameters	2
	4.1. Performance parameters	2
	4.2. Electrical and mechanical parameters	3
	4.3. Optical parameters	4
5.	Installation and Use.....	4
	5.1. Product dimensions	4
	5.2. Assembly diagram	5
	5.3. Communication interface	5
	5.4. Data communication	5
	5.5. Coordinate system definition	6
6.	Safety and Scope of Application.....	6
7.	Remarks.....	6
	7.1. Target surface reflectivity	7
	7.2. Ranging accuracy	7
8.	Revision Records	7

1. Product Description

The STL-19P consists mainly of a laser ranging core, a wireless power transmission unit, a wireless communication unit, an angle measuring unit, a motor drive unit and a mechanical housing.

With DTOF technology, STL-19P ranging core is able to perform 5,000 measurements per second. For each ranging, the LiDAR emits an infrared laser, which is reflected back to the single photon receiving unit when it encounters the target object. From this, we obtain the time at which the laser is emitted and that at which it is received by the single photon receiving unit. The time difference between them is the time of flight of the light, which can be combined with the speed of light to solve for the distance. Once the distance data have been obtained, STL-19P fuses the angle values measured by the angle measuring unit to form the point cloud data and then sends the point cloud data to an external interface via wireless communication. Meanwhile the external interface supports PWM input to enable the motor drive unit to drive the motor rotation. The external control unit obtains the speed and controls it to the specified speed by means of a PID algorithm in closed-loop control, thus allowing the LiDAR to work stably.

The diagram of the environmental scan formed by STL-19P point cloud data is shown below:

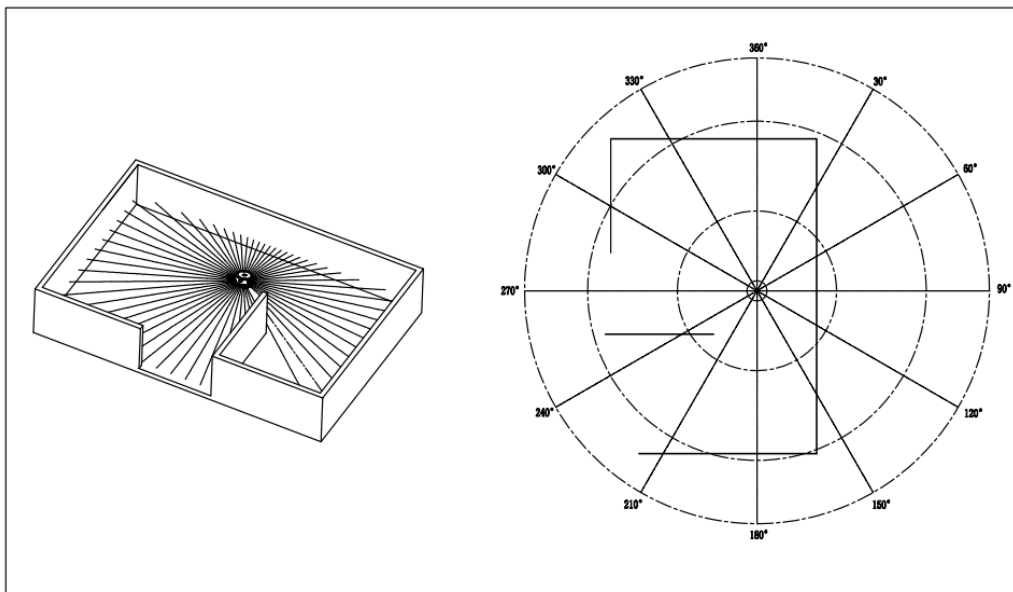

The product is mainly suitable for the navigation and obstacle avoidance of robots (e.g. floor mopping robots and service robots) by performing a 360° scan of the indoor layout and building a map so that a walking path can be planned. It is also suitable for robotics education and research, etc.

2. Product Features

Main features of STL-19P LiDAR:

- High ranging accuracy at close range, with a mean error of $\pm 10\text{mm}$ over a distance of 0.03 to 0.5m;
- Compact footprint, easy to integrated design, guaranteeing the aesthetics of the
- High resistance to ambient light interference, for use in environments up to 60Klux;
- Supporting for glass wall detection;
- Stable performance with a lifetime of up to 10,000 hours;

3. Introduction to Functions

3.1. 360° scanning for ranging

The STL-19P LiDAR scans at 10Hz by default and measures distance at a rate of 5,000 times per second. Output of ranging information (including distance and angle data) for 360° surroundings via UART interface.

3.2. PWM speed control

STL-19P is furnished with a stepless speed regulation motor drive and supports both internal and external speed control. When the PWM pin is grounded, the internal speed regulation is available by default, at the speed of 10Hz by default. External speed control requires a square signal to be connected to the PWM pin, which can be used to control the start, stop and speed of the motor via the PWM signal duty ratio. Due to individual differences in each product motor, the actual speed may vary when the duty ratio is set to typical values. For precise control of the motor speed, closed-loop control is required based on the speed information in the received data.

Notes: When external speed control is not used, the PWM pin must be grounded.

3.3. Glass detection

With multi-echo detection technology, the STL-19P supports glass wall detection (within $\pm 5^\circ$ of the angle of incidence and normal), reducing collisions during robot operation, extending the life of the whole machine and improving the user experience.

4. Technical Parameters

4.1. Performance parameters

Parameter name	Unit	Minimum value	Typical value	Maximum value	Remarks
Ranging scope	m	0.03~12m			Tested on a white target with 80% reflectivity
		0.03~8m			Tested on a black target with 4% reflectivity

Ranging accuracy	m	$\pm 10\text{mm}@0.03\text{-}0.5\text{m}$, STD 2mm; $\pm 20\text{mm}@0.5\text{-}2\text{m}$, STD 4mm; $\pm 30\text{mm}@2\text{m}\text{-}12\text{m}$, STD 15mm (white target with 80% reflectivity); $\pm 30\text{mm}@2\text{m}\text{-}8\text{m}$, STD 15mm (black target with 4% reflectivity);			See remark "ranging accuracy" for detailed description
Scanning frequency	Hz	6	10	13	PWM speed control provided externally
Ranging frequency	Hz	-	5000Hz	-	Fixed frequency
Pitch angle error	°	0.5	-	2°	
Yaw angle error	°	-1	0	1	
Angular resolution	°	-	0.72° @10Hz	-	Typical value 0.72°@10Hz
Anti-background light	KLux	-	-	60	Refer to the ambient light test specification of LDROBOT
Acoustic noise	dB	-	-	45dB	The lidar is placed horizontally forward, and the noise meter (Smart sensor AR824) is tested at a distance of 30 cm.
Machine life	h	10000	-	-	
Working temperature	°C	-10	25	45	
Storage temperature	°C	-30	25	70	
Dust and water resistant			IP5X		See remark "Dust and water resistant" for detailed description

4.2. Electrical and mechanical parameters

Parameter name	Unit	Minimum value	Typical value	Maximum value	Remarks
Input voltage	V	4.5	5	5.5	
PWM control frequency	KHz	20	30	50	Square signal
PWM high level	V	3.0	3.3	3.6	
PWM low level	V	-0.3	0	0.5	
PWM duty ratio	%	0	40	100	40% duty ratio, scan frequency of 10Hz

Starting current	mA	-	TBD	-	
Working current	mA	-	290	-	
Machine dimension	mm	54.00*46.29*35.0 (L*W*H)			
Machine weight*	g	-	45	-	Without connecting line
Communication interface	-	UART @ 230400			
UART high level	V	3.0	3.3	3.6	
UART low level	V	-0.3	0	0.5	
Driving motor	-	BLDC			Brushless motor

Remarks: Actual weight may vary depending on configuration, manufacturing process, and measurement methods.

4.3. Optical parameters

Parameter name	Unit	Minimum value	Typical value	Maximum value	Remarks
Optical maser wavelength	nm	895	905	915	Infrared band
Laser safety level	-	IEC-60825 Class 1			

5. Installation and Use

5.1. Product dimensions

The laser emission and reception in the ranging unit of the STL-19P requires an optical window, which needs to be exposed in the structure. The partial occlusion of this window by external systems will affect the ranging performance of the LiDAR to some extent. The diagram below shows the optical window dimensions (in mm).

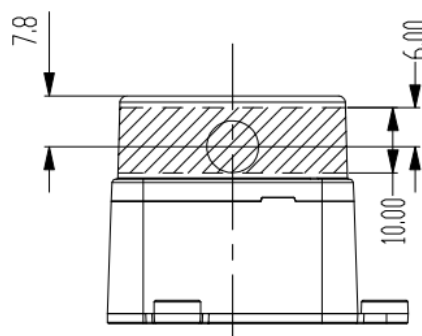

Other mounting dimensions are shown in the following diagram with a tolerance of ± 0.2 (in mm):

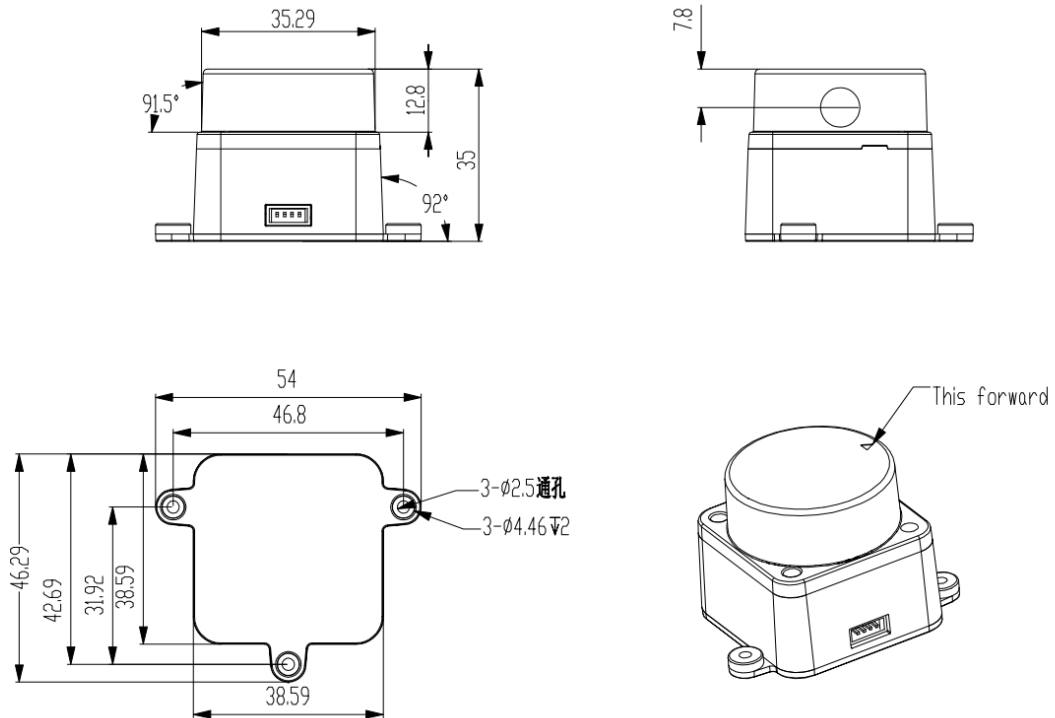

5.2. Assembly diagram

LiDAR assembly diagrams, typical design references and constraints, as specified in the STL-19P design guidelines.

5.3. Communication interface

STL-19P is connected to external systems via a ZH1.5T-4P1.5mm connector for power supply and data reception, with the interface definitions and parameter requirements shown in the following diagram/table:

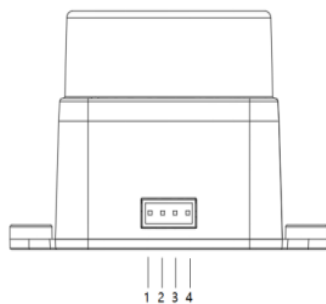

S/N	Signal name	Type	Description	Minimum value	Typical value	Maximum value
1	Tx	Output	LiDAR data output	0V	3.3V	3.6V
2	PWM	Input	Motor control signal	0V	-	3.6V
3	GND	Power supply	Negative pole	-	0V	-
4	P5V	Power supply	Positive pole	4.5V	5V	5.5V

Notes: When external speed control is not used, the PWM pin must be grounded.

5.4. Data communication

The data communication of the STL-19P is sent in one direction using a Universal

Asynchronous Receiver Transmitter (UART) with the transmission parameters shown in the following table:

Baud rate	Data length	Stop bit	Parity check bit	Flow control
230400	8 Bits	1	N/A	N/A

With one-way communication, STL-19P starts sending measurement data as soon as the rotation is stabilized, without sending any commands. The measurement data follow the serial software communication protocol of module. See STL-19P development manual.

5.5. Coordinate system definition

The STL-19P commonly follows a left-hand rule coordinate system where the front of the sensor is defined as the X-axis of the coordinate system (i.e. the 0-angle position), the origin of the coordinate system is the center of rotation of the ranging unit, and the angle of rotation increases along the clockwise direction, as shown in the following diagram:

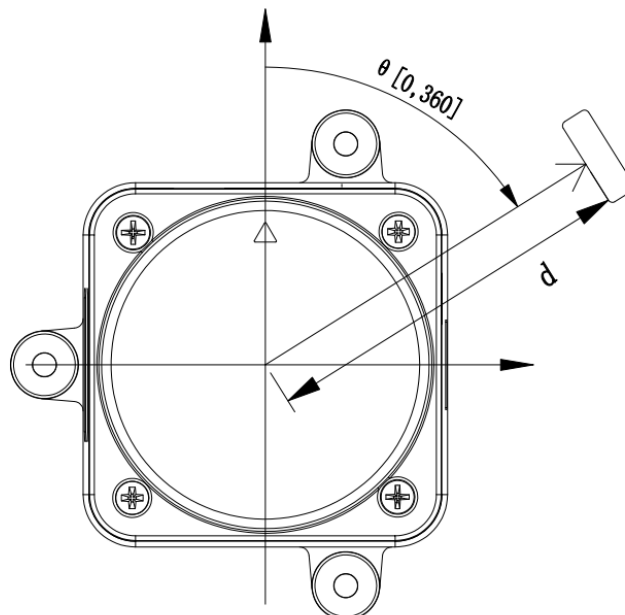

6. Safety and Scope of Application

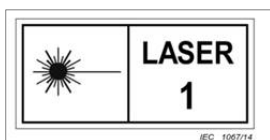

STL-19P is provided with a low-powered infrared laser as the emitting light source to ensure safety for humans and pets. It is qualified in the tests of Class I laser safety standards. The STL-19P complies with 21 CFR 1040.10 and 1040.11 with the exception of deviations from Laser Notice No. 50 dated June 24, 2007.

Attention: Self-adjustment or modification of this product may result in dangerous radiation exposure.

7. Remarks

7.1. Target surface reflectivity

- 1、 The reflectivity represents the test result of the C84-III reflectivity tester;



- 2、 The reflectivity of white target in LDROBOT laboratory is 80.6%; that of the black target is 4.1%.

7.2. Ranging accuracy

Parameter indexes of the ranging accuracy:

- ±10mm@0.03-0.5m, STD 2mm;
- ±20mm@0.5-2m, STD 4mm;
- ±30mm@2m-12m, STD 15mm (white target with 80% reflectivity);
- ±30mm@2m-8m, STD 15mm (black target with 4% reflectivity);

Among them, ±10mm@0.03-0.5m, STD2mm indicates a measurement accuracy of ±10mm (mean error) over a range of 0.03 to 0.5m, with an accuracy of 2mm (STD-overall standard deviation, 1σ). Refer to these for other indicators.

8. Revision Records

Version	Revision date	Revision contents
V1.0	2023-09-28	Initial creation