



## LCD MODULE SPECIFICATION

Customer: \_\_\_\_\_

Module No.: TL034WVS05CT-B1477A

Date: 2023-3-30

Version: 3.0

For Customer's Acceptance:

Approved by	Comment

Approved by	Checked by	Prepared by
Kanglin.Zhong	Xianren.Zhou	Zaiping.Yang



## Table of Contents

Record of Revision.....	3
1 General Specifications.....	4
2 Pin Assignment.....	5
3 Absolute Maximum Ratings .....	6
4. Electrical Characteristics .....	6
5 Timing Chart.....	7
6 Optical Characteristics .....	<a href="#">11</a>
7 Environmental / Reliability Test .....	<a href="#">14</a>
8 Mechanical Drawing.....	<a href="#">15</a>
9 Precautions for Use of LCD Modules .....	<a href="#">16</a>



### Record of Revision

Rev.	Date	Description	Editor
1.0	2021-3-16	First release	
2.0	2021-3-08	Change Mechanical Drawing	
3.0	2023-3-30	Update the temperature parameters	Zaipng.Yang

## 1 General Specifications

No.	Item	Specification	Remark
1	LCD Size	3.4 inch (Diagonal)	
2	Driver Element	a-Si TFT active matrix	
3	Resolution	480 (RGB) × 480	
4	Display Mode	Normally Black, Transmissive	
5	Pixel Pitch	0.042 (H) × 0.126(V)	
6	Display Colors	16.7M	
7	Surface Treatment	--	
8	Color Arrangement	RGB-Stripe	
9	Interface	3W SPI+RGB18bit	
10	Viewing Direction	All	
11	Gray Scale Inversion Direction	/	Note 1
12	Outline Dimension (mm)	76.5(W) × 76.5 (H) × 3.20T)	
13	Active Area (mm)	60.48(W) × 60.48 (H)	
14	Touch Screen	With CTP	
15	Display Driver IC	ST7701S	
16	Touch Driver IC	FT6336U	

Note 1: Viewing direction for best image quality is different from TFT definition. There is a 180° shift.

Note 2: RoHS compliant.

## 2 Pin Assignment

### 2.1 LCD Pin assignment

Match connector: XF2M-4015-1A (OMRON) or equivalent.

N	Symbol	I/O	Description	Remark
1	LED A	P	LED ANODE	
2	LED K1	P	LED1 CATHODE	
3	LED K2	P	LED2 CATHODE	
4	GND	P	Ground	
5	VCI	P	Power supply	
6	RESET	I	Reset Signal ,Active Low	
7	TE	-	NC,No connection	
8	PWM	-	NC,No connection	
9	SDA	I	SPI Data signal	
10	SCK	I	SPI Clock signal	
11	CS	I	SPI Chip select signal	
12	PCLK	I	RGB dot clock signal	
13	DE	I	RGB data enable signal	
14	VSYNC	I	RGB frame synchronizing signal	
15	HSYNC	I	RGB line synchronizing signal	
16~33	DB0~DB17	I	RGB data signal: DB0:BLUE LSB--DB5:BIUE MSB; DB6:GREEN LSB--DB11:GREEN,MSB; DB12:RED LSB--DB17:RED MSB.	
34	GND	P	Ground	
35	TP_INT	I	Touch Interrupt	
36	TP_SDA	I/O	Touch IIC Data signal	
37	TP_SCL	I	Touch IIC Clock signal	
38	TP_RESET	I	Touch Reset Signal	
39	TP_VCI	P	Touch Power supply	
40	GND	P	Ground	

I---Input, O---Output, P--- Power/Ground

### 3 Absolute Maximum Ratings

 $T_a = 25^{\circ}\text{C}$ 

Item	Symbol	Min.	Max.	Unit	Remark
Power Voltage	VCI	-0.30	+4.6	V	
	TP-VCI	-0.30	+3.6	V	
Operating Temperature	Top	-20.0	70.0	$^{\circ}\text{C}$	
Storage Temperature	T <sub>st</sub>	-30.0	80.0	$^{\circ}\text{C}$	
Operating and Storage Humidity	H <sub>stg</sub>	10%	90%	%(RH)	

### 4. Electrical Characteristics

#### 4.1 Recommended Operating Condition

 $V_{CI}=3.3\text{V}$ ,  $GND=0\text{V}$ ,  $T_a = 25^{\circ}\text{C}$ 

Item	Symbol	Min.	Typ.	Max.	Unit	Remark
Power supply Voltage	VCI	2.5	2.8	3.3	V	
TP Power	TP-VCI	2.8	3.0	3.3	V	
TP Power	TP-IOVCC	-	-	-	V	
Input Signal Voltage	Low Level V <sub>IL</sub>	0	-	0.3 x IOVCC	V	
	High Level V <sub>IH</sub>	0.7 x IOVCC	-	VCI	V	
Power supply voltage	I <sub>VCI</sub>	-	30	50	mA	VCI=3.3V, color bar pattern

#### 4.2 Backlight Unit Driving Condition

Item	Symbol	Min.	Typ.	Max.	Unit	Remark
Forward Current	I <sub>F</sub>	-	40	50	mA	8 LEDs (4 LED Serial, 2 LED Parallel)
Forward Current Voltage	V <sub>F</sub>	-	12.8	14	V	
Backlight Power Consumption	W <sub>BL</sub>	-	512	700	mW	
Operating Life Time	--	30000	--	--	hrs	Note 2, Note 3

Note1: The LED driving condition is defined for each module (4 LED Serial, 2 LED Parallel).

Note2: When LCM is operated, the stable forward current should be inputted. And forward voltage is for reference only.

Note3: Optical performance should be evaluated at  $T_a=25^{\circ}\text{C}$  When LED is driven at high current, high ambient temperature & humidity condition. The life time of LED will be reduced. Operating life means brightness goes down to 50% initial brightness. Typical operating life time is estimated data.

Note4: The LED driving condition is defined for each LED module.

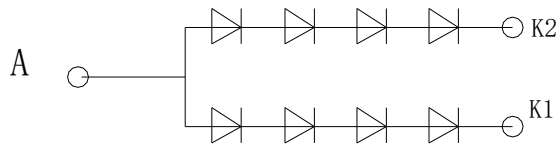

## 5 Timing Chart

### 5.1 Serial Interface Characteristics (3-line serial):

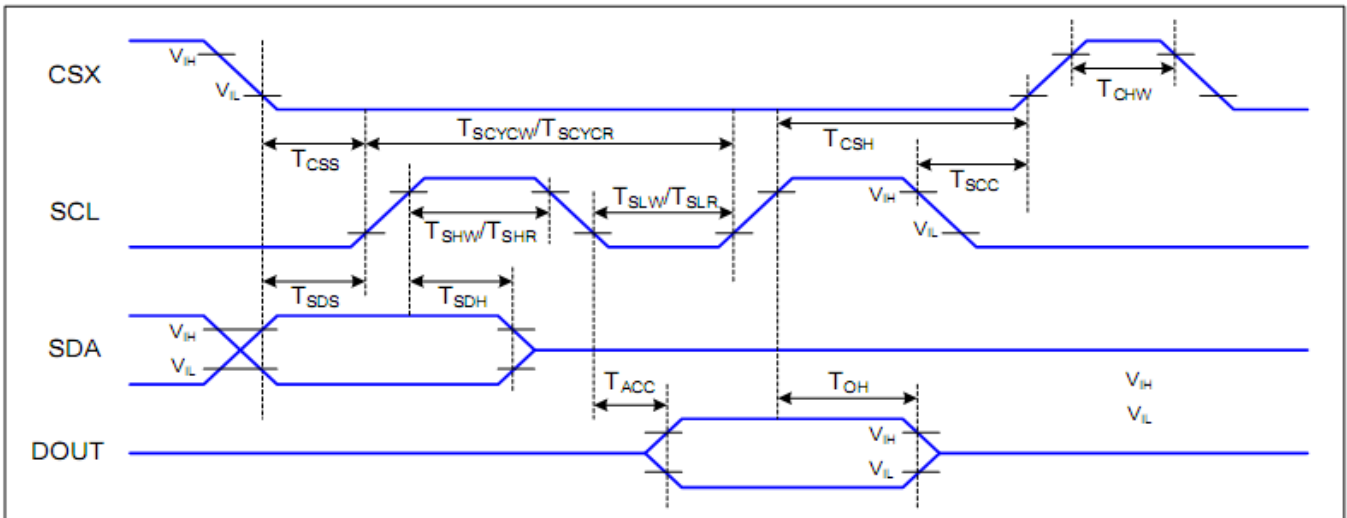

3-line serial Interface Timing Characteristics

VDD=2.8, AGND=DGND=0V, Ta=25°C

Signal	Symbol	Parameter	Min	Max	Unit	Description
CSX	T <sub>CSS</sub>	Chip select setup time (write)	15		ns	
	T <sub>CSH</sub>	Chip select hold time (write)	15		ns	
	T <sub>CSS</sub>	Chip select setup time (read)	60		ns	
	T <sub>SCC</sub>	Chip select hold time (read)	60		ns	
	T <sub>CHW</sub>	Chip select "H" pulse width	40		ns	
SCL	T <sub>SCYCW</sub>	Serial clock cycle (Write)	66		ns	
	T <sub>SHW</sub>	SCL "H" pulse width (Write)	15		ns	
	T <sub>SLW</sub>	SCL "L" pulse width (Write)	15		ns	
	T <sub>SCYCR</sub>	Serial clock cycle (Read)	150		ns	
	T <sub>SHR</sub>	SCL "H" pulse width (Read)	60		ns	
	T <sub>SLR</sub>	SCL "L" pulse width (Read)	60		ns	
SDA (DIN)	T <sub>SDS</sub>	Data setup time	10		ns	
	T <sub>SDH</sub>	Data hold time	10		ns	

3-line serial Interface Characteristics

Note : The rising time and falling time (Tr, Tf) of input signal are specified at 15 ns or less. Logic high and low levels are specified as 30% and 70% of VDDI for Input signals.

## 5.2 TFT-LCD Input Clock and Data timing Diagram:

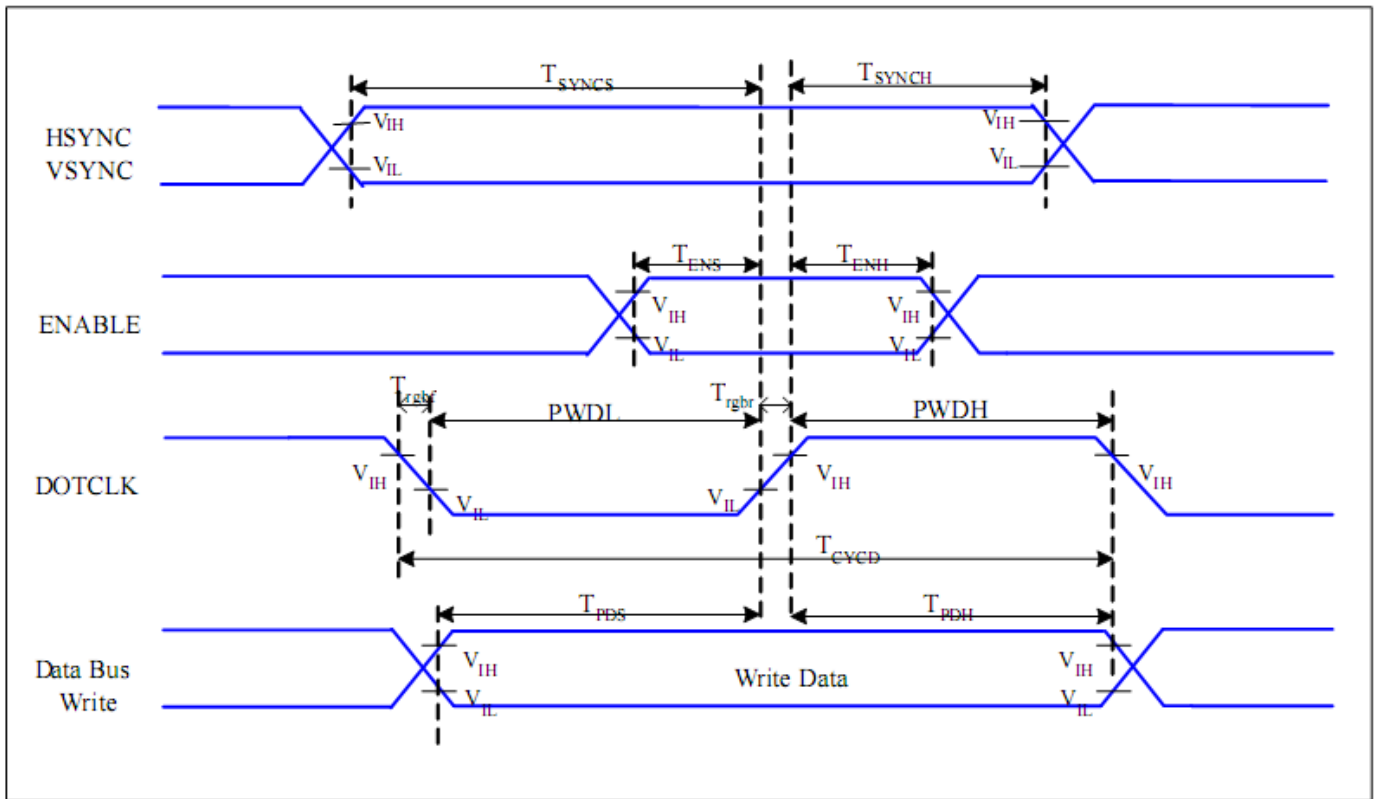

$V_{DD}=2.8, AGND=DGND=0V, T_a=25\text{ }^{\circ}\text{C}$

Signal	Symbol	Parameter	MIN	MAX	Unit	Description
HSYNC, VSYNC	$T_{SYNCS}$	VSUNC, HSYNC Setup Time	5	-	ns	
ENABLE	$T_{ENS}$	Enable Setup Time	5	-	ns	
	$T_{ENH}$	Enable Hold Time	5	-	ns	
DOTCLK	PWDH	DOTCLK High-level Pulse Width	15	-	ns	
	PWDL	DOTCLK Low-level Pulse Width	15	-	ns	
	$T_{CYCD}$	DOTCLK Cycle Time	33	-	ns	
	Trghr, Trghf	DOTCLK Rise/Fall time	-	15	ns	
DB	$T_{PDS}$	PD Data Setup Time	5	-	ns	
	$T_{PDH}$	PD Data Hold Time	5	-	ns	

**18Bits RGB Interface Timing Characteristics**



### 5.3 Recommended Timing Setting of TCON

TCON (Embedded in Source IC) Input Timing (DCLK, HS, VS, DE)

VCI=2.8V, GND=0V, Ta=25°C

Parameter	Symbol	Min.	Typ.	Max.	Unit	Remark
DCLK	Fclk	-	16	-	MHz	
	tclk	-	62.5	-	ns	
HSD	hdisp	-	480	-	tclk	
	hpw	-	10	-	tclk	
	hbp	-	20	-	tclk	
	hfp	-	10	-	tclk	
VSD	vdisp	-	480	-	th	
	vs	-	6	-	th	
	vbp	-	10	-	th	
	vfp	-	10	-	th	

Note: For reference only, it needs to be adjusted according to the actual display effect

### 5.4 Reset input timing

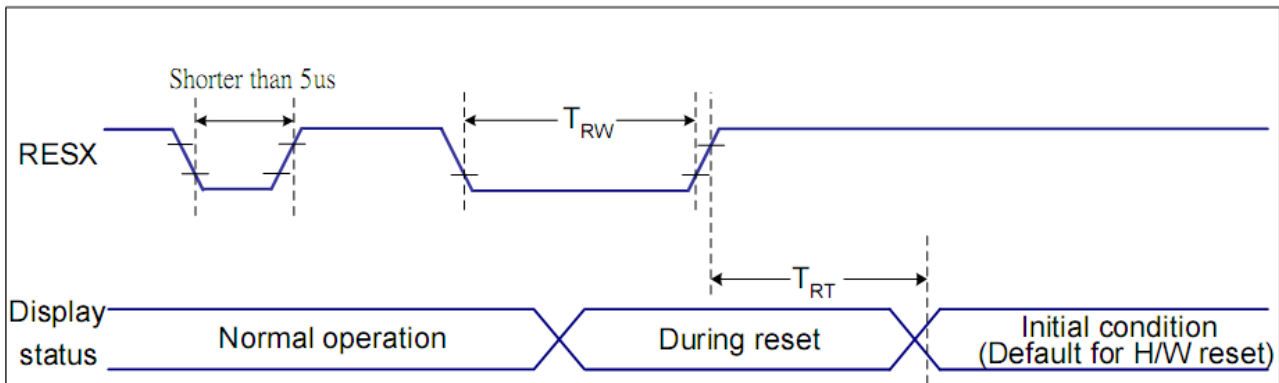

Figure Reset Timing

VCI=2.8, AGND=DGND=0V, Ta=25 °C

Related Pins	Symbol	Parameter	MIN	MAX	Unit
RESX	TRW	Reset pulse duration	10	-	us
	TRT	Reset cancel	-	5	ms
			120	ms	

Table Reset Timing

## 5.5 Power On/Off Timing

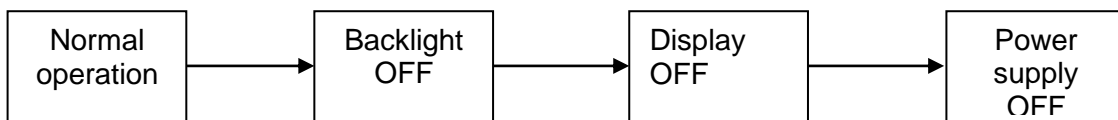
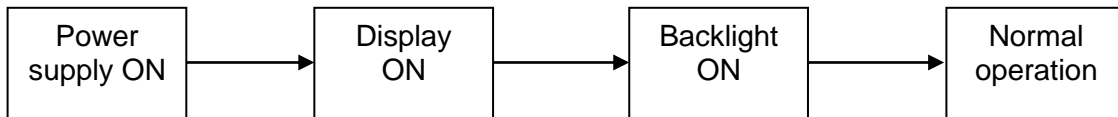
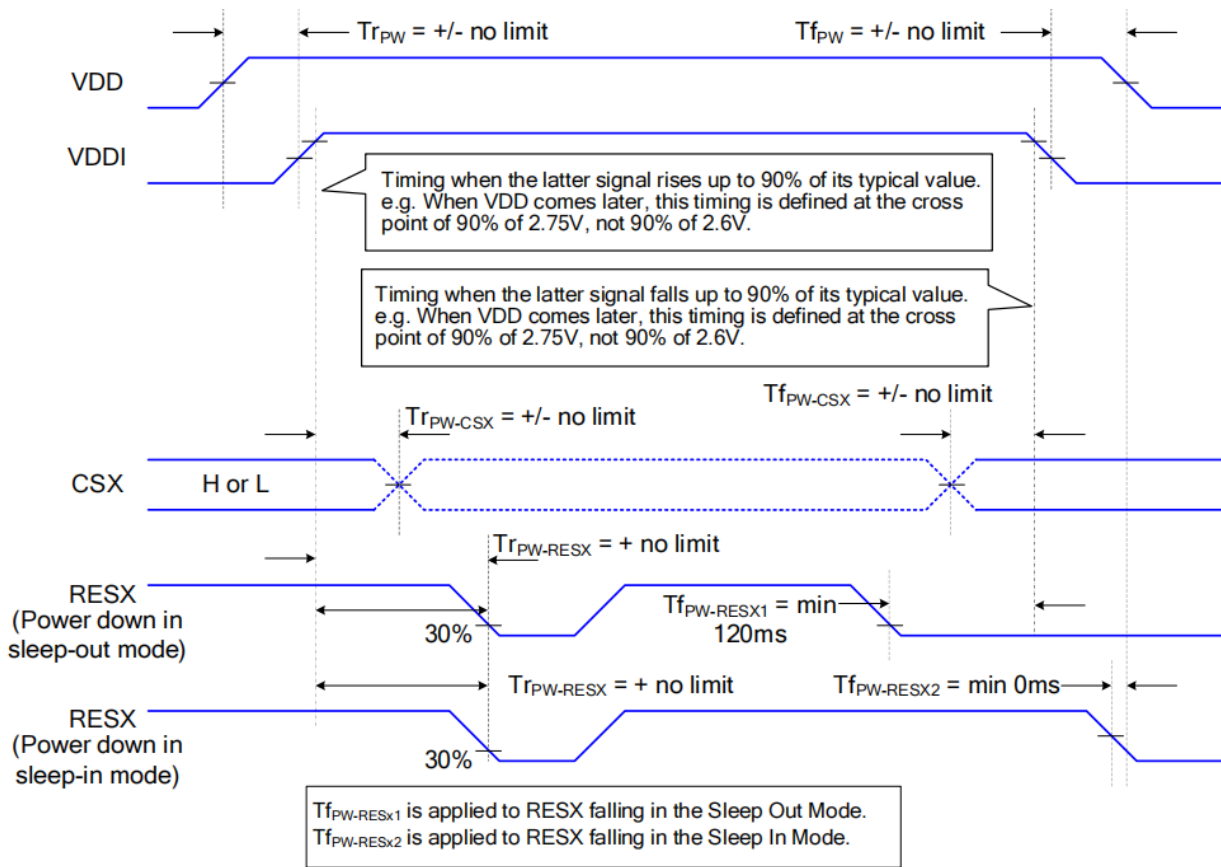

## 6 Optical Characteristics

Ta=25°C

Item	Symbol	Condition	Min.	Typ.	Max.	Unit	Remark
View Angles	$\theta T$	$CR \geq 10$	75	85	-	Degree	Note 2
	$\theta B$		75	85	-		
	$\theta L$		75	85	-		
	$\theta R$		75	85	-		
Contrast Ratio	CR	$\theta=0^\circ$	800	1000	-		Note1 Note3
Response Time	$T_{ON}$	25°C	-	30	35	ms	Note1 Note4
	$T_{OFF}$						
Chromaticity	White	Backlight is on	x	0.271	0.301	0.331	Note1 Note5
			y	0.300	0.330	0.360	
	Red		x	0.607	0.637	0.667	
			y	0.280	0.310	0.340	
	Green		x	0.235	0.265	0.295	
			y	0.550	0.580	0.610	
	Blue		x	0.100	0.130	0.160	
			y	0.050	0.080	0.110	
Uniformity	U		75	80	-	%	Note1 Note6
NTSC			67	72	-	%	Note 5
Luminance	L		-	250	-	cd/m <sup>2</sup>	Note1 Note7

Test Conditions:

1.  $I_F=40\text{ mA}$ ,  $V_F=12.8\text{ V}$  and the ambient temperature is  $25\pm 2^\circ\text{C}$ . humidity is  $65\pm 7\%$
2. The test systems refer to Note 1 and Note 2.

**Note 1: Definition of optical measurement system.**

Properties are measured at the center point of the LCD screen. All input terminals LCD panel must be ground when measuring the center area of the panel.

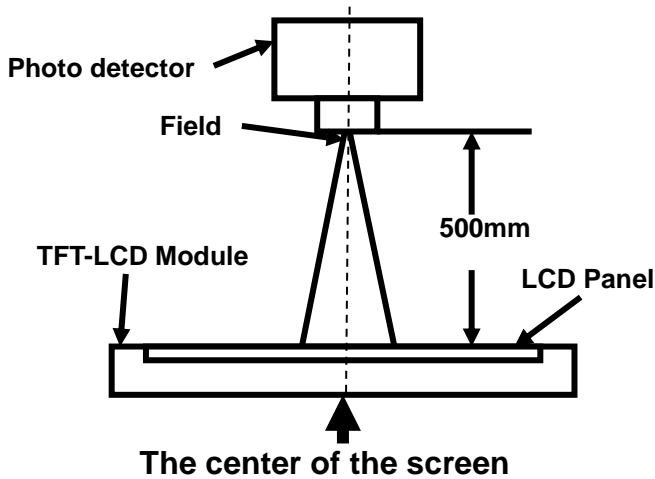

Item	Photo detector	Field
Contrast Ratio	SR-3A	1°
Luminance		
Chromaticity		
Lum Uniformity		
Response Time	BM-7A	2°

**Note 2: Definition of viewing angle range and measurement system.**

Viewing angle is measured at the center point of the LCD by CONOSCOPE(ergo-80).

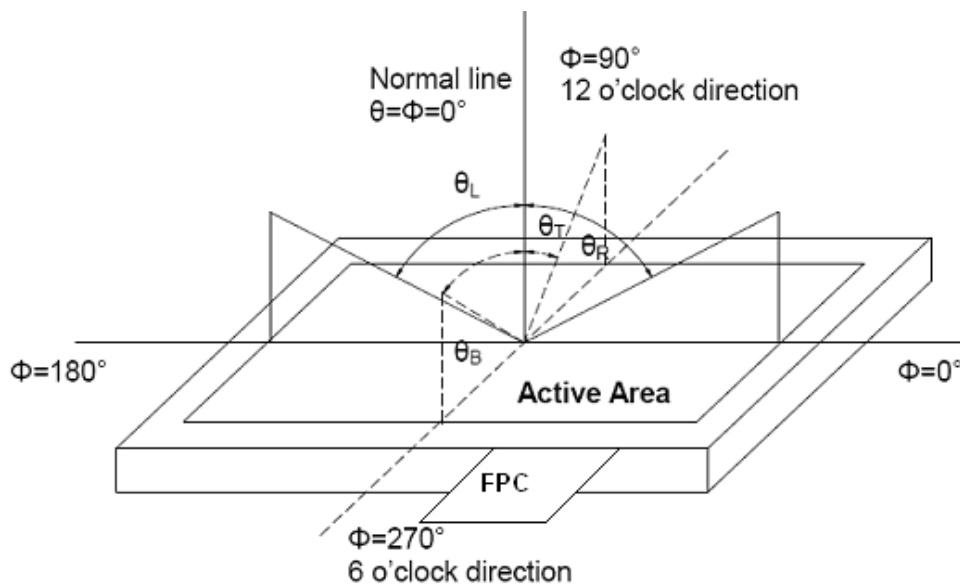

**Note 3: Definition of contrast ratio**

$$\text{Contrast ratio (CR)} = \frac{\text{Luminance measured when LCD is on the "White" state}}{\text{Luminance measured when LCD is on the "Black" state}}$$

“White state “: The state is that the LCD should drive by V<sub>white</sub>.

“Black state”: The state is that the LCD should drive by V<sub>black</sub>.

V<sub>white</sub>: To be determined    V<sub>black</sub>: To be determined.

**Note 4: Definition of response time**

The response time is defined as the LCD optical switching time interval between “White” state and “Black” state. Rise time ( $T_{ON}$ ) is the time between photo detector output intensity changed from 90% to 10%. And fall time ( $T_{OFF}$ ) is the time between photo detector output intensity changed from 10% to 90%.

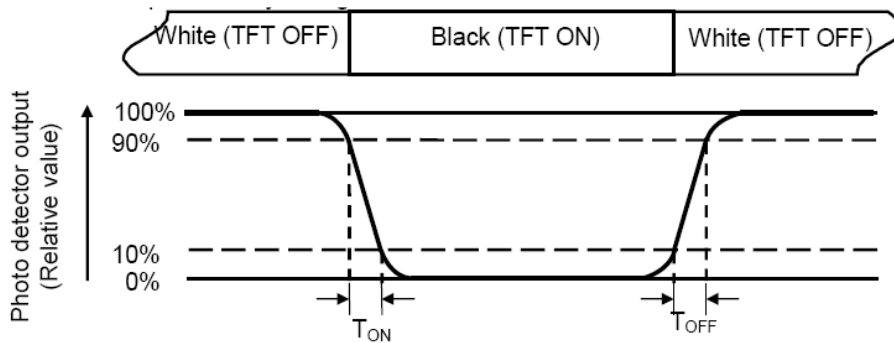

**Note 5: Definition of color chromaticity (CIE1931)**

Color coordinates measured at center point of LCD.

**Note 6: Definition of luminance uniformity**

Active area is divided into 9 measuring areas (Refer Fig. 2). Every measuring point is placed at the center of each measuring area.

Luminance Uniformity ( $U$ ) =  $L_{min} / L_{max}$

L-----Active area length W----- Active area width

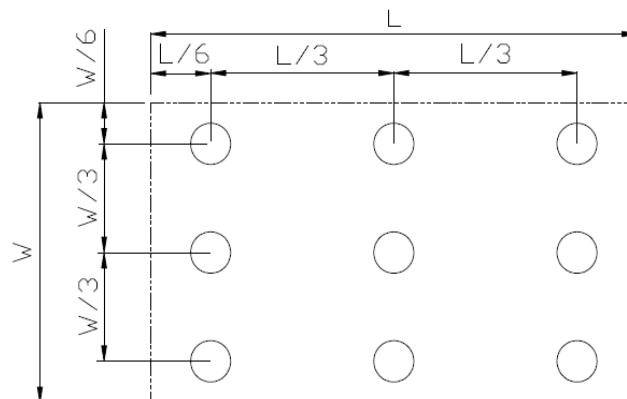

$L_{max}$ : The measured Maximum luminance of all measurement position.

$L_{min}$ : The measured Minimum luminance of all measurement position.

**Note 7: Definition of luminance:**

Measure the luminance of white state at center point.

## 7 Environmental / Reliability Test

No	Test Item	Condition	Remarks
1	High Temperature Operation	Ts = +70°C, 240 hours	No abnormalities in functions
2	Low Temperature Operation	Ta = -20°C, 240 hours	No abnormalities in functions
3	High Temperature Storage	Ta = +80°C, 240 hours	No abnormalities in functions
4	Low Temperature Storage	Ta = -30°C, 240 hours	No abnormalities in functions
5	Storage at High Temperature and Humidity	Ta = +60°C, 90% RH max, 240 hours	No abnormalities in functions
6	Thermal Shock (non-operating)	-30°C 30 min ~ +70°C 30 min, Change time: 0.5 hour ← 5 min → 0.5 hour. 10 Cycle	Start with cold temperature, End with high temperature,
7	ESD	C=150pF, R=330Ω, 5point/panel Air: ±6Kv, 5times; Contact: ±4Kv, 5times (Environment: 15°C ~ 35°C, 30% ~ 60%. 86Kpa ~ 106Kpa)	No abnormalities in functions

Note1: Ts is the temperature of panel's surface.

Note2: Ta is the ambient temperature of samples.

# 8 Mechanical Drawing

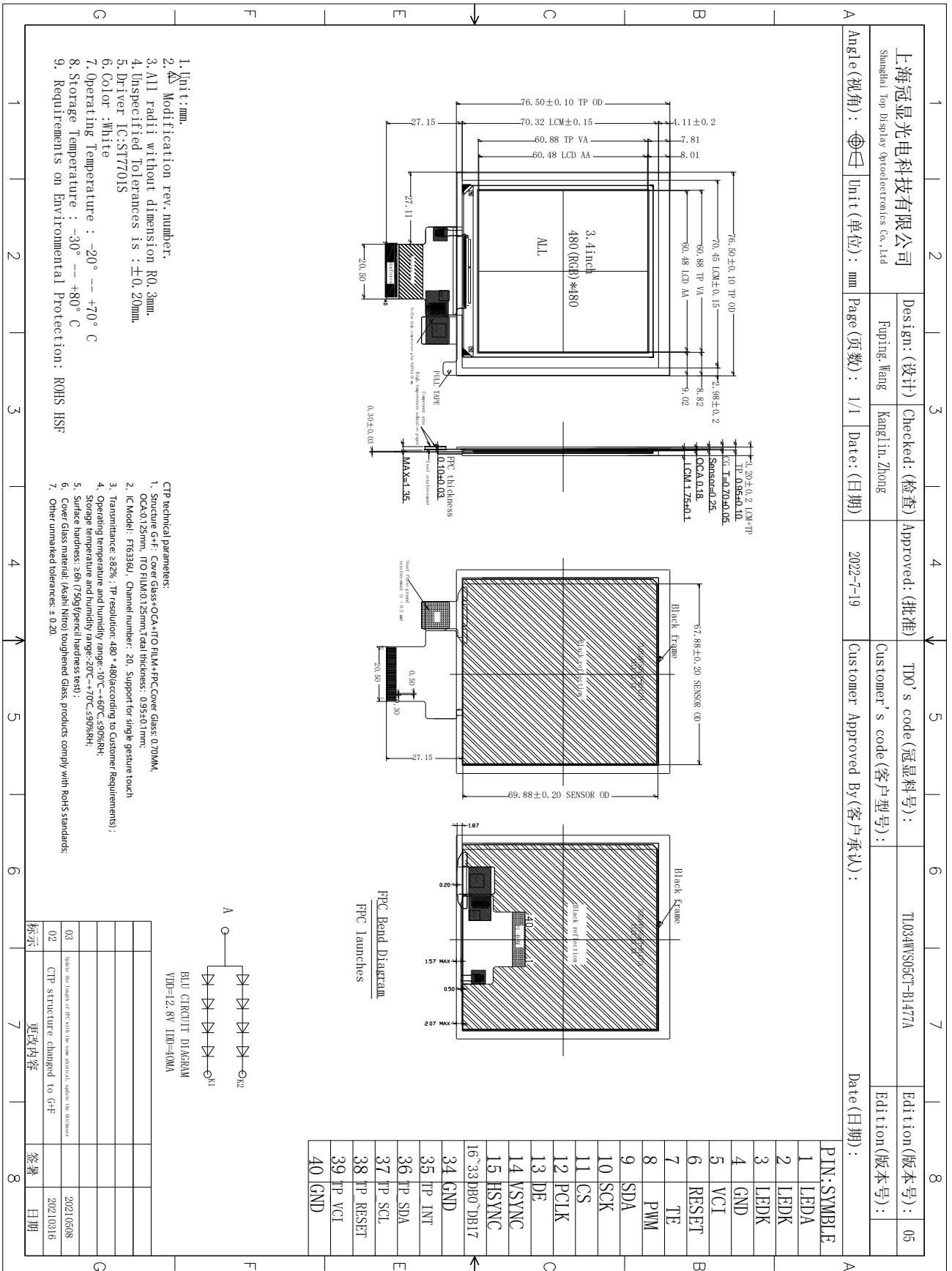

## 9 Precautions for Use of LCD Modules

### Handling Precautions

9.1.1 The display panel is made of glass. Do not subject it to a mechanical shock by dropping it from a high place, etc.

9.1.2 If the display panel is damaged and the liquid crystal substance inside it leaks out, be sure not to get any in your mouth, if the substance comes into contact with your skin or clothes, promptly wash it off using soap and water.

9.1.3 Do not apply excessive force to the display surface or the adjoining areas since this may cause the color tone to vary.

9.1.4 The polarizer covering the display surface of the LCD module is soft and easily scratched. Handle this polarizer carefully.

9.1.5 If the display surface is contaminated, breathe on the surface and gently wipe it with a soft dry cloth. If still not completely clear, moisten cloth with one of the following solvents:

- Isopropyl alcohol
- Ethyl alcohol

Solvents other than those mentioned above may damage the polarizer. Especially, do not use the following:

- Water
- Ketone
- Aromatic solvents

9.1.6 Do not attempt to disassemble the LCD Module.

9.1.7 If the logic circuit power is off, do not apply the input signals.

9.1.8 To prevent destruction of the elements by static electricity, be careful to maintain an optimum work environment.

9.1.8.1 Be sure to ground the body when handling the LCD Modules.

9.1.8.2 Tools required for assembly, such as soldering irons, must be properly ground.

9.1.8.3 To reduce the amount of static electricity generated, do not conduct assembly and other work under dry conditions.

9.1.8.4 The LCD Module is coated with a film to protect the display surface. Be care when peeling off this protective film since static electricity may be generated.

### Storage Precautions

9.2.1 When storing the LCD modules, avoid exposure to direct sunlight or to the light of fluorescent lamps.

9.2.2 The LCD modules should be stored under the storage temperature range. If the LCD modules will be stored for a long time, the recommend condition is: Temperature : 0°C ~ 40°C      Relatively humidity: ≤80%

9.2.3 The LCD modules should be stored in the room without acid, alkali and harmful gas.

### Transportation Precautions

9.3.1 The LCD modules should be no falling and violent shocking during transportation, and also should avoid excessive press, water, damp and sunshine.