

GNSS/Dead Reckoning Module – ublox ZED-F9R

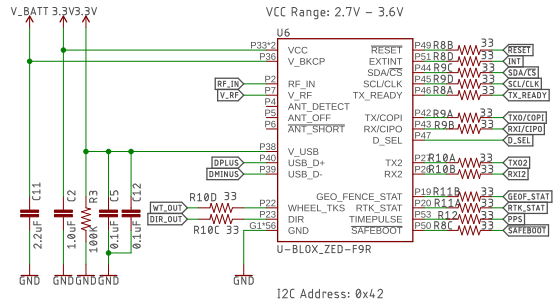

USB-C and Voltage Regulation: AP2112K

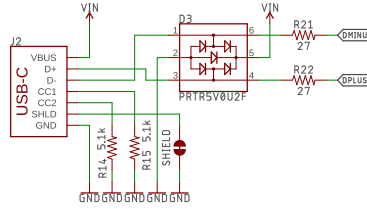

Battery

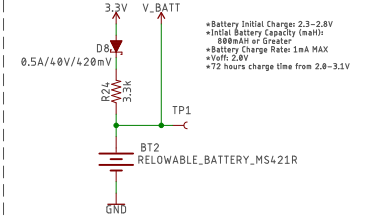
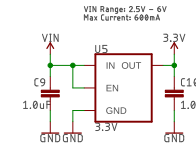

Wheel Tick and Direction Signal

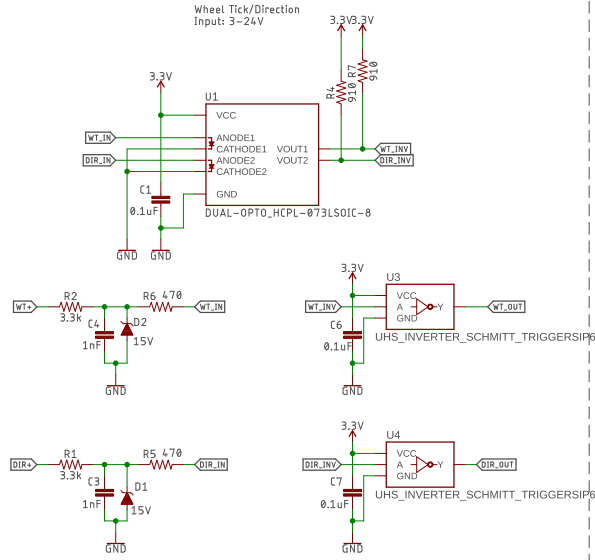

Antenna

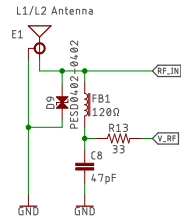

Jumpers

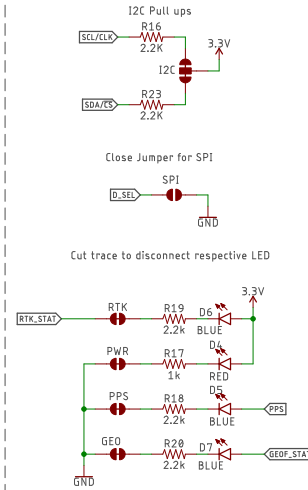

Connectors

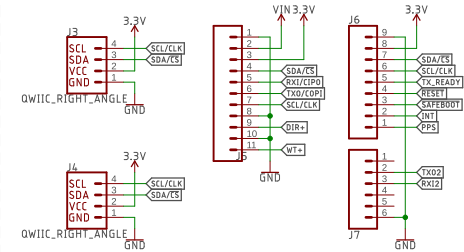

Released under the Creative Commons Attribution Share-Alike 4.0 License <https://creativecommons.org/licenses/by-sa/4.0/>

TITLE: SparkFun\_ZED-F9R\_v11

Design by: Elias Santistevan

REV: v11

Date: 7/12/2023 9:33 AM

Sheet: 1/1