

# S905X3

## Datasheet

---

Revision: 02

Release Date: 2020-03-31

Confidential for Hardkernel!

---

## Copyright

©2020 Amlogic. All rights reserved. No part of this document may be reproduced, transmitted, transcribed, or translated into any language in any form or by any means without the written permission of Amlogic.

## Trademarks

 , and other Amlogic icons are trademarks of Amlogic companies. All other trademarks and registered trademarks are property of their respective holders.

## Disclaimer

Amlogic may make improvements and/or changes in this document or in the product described in this document at any time.

This product is not intended for use in medical, life saving, or life sustaining applications.

Circuit diagrams and other information relating to products of Amlogic are included as a means of illustrating typical applications. Consequently, complete information sufficient for production design is not necessarily given. Amlogic makes no representations or warranties with respect to the accuracy or completeness of the contents presented in this document.

## Contact Information

- Website: [www.amlogic.com](http://www.amlogic.com)
- Pre-sales consultation: [contact@amlogic.com](mailto:contact@amlogic.com)
- Technical support: [support@amlogic.com](mailto:support@amlogic.com)

# Revision History

## Issue 02 (2020-03-31)

This is the 02 version. Compared to the previous version, the following topics are changed:

Section	Change Description
10	Updated the figure of audio path.
7.2.2 7.4	Deleted L2 cache description.
7.9.3.7	Modified the description of PAD_DS_REG2B register.
2 3	Updated HDCP 2.2 to HDCP 2.2/2.3.

## Issue 01 (2019-12-06)

This is the 01 version. Compared to the previous version, the descriptions in several topics are optimized.

## Issue 0.2 (2019-11-21)

This is the 0.2 version.

Compared to the previous version, the following topic is added:

- 1

Compared to the previous version, the following topics are changed:

Section	Change Description
3	Changed the specification of H.264 video encoding.
5.5.1	Changed the maximum specification of $R_{pd}$ .
5.5.2	Added a note explaining "OD 5V".
5.11	Changed the maximum current specification of VDDCPU and VDDQ.

## Issue 0.1 (2019-06-04)

This is the initial release.

# Contents

Revision History .....	ii
<b>1 About This Document</b> .....	1
<b>2 General Description</b> .....	2
<b>3 Features Summary</b> .....	3
<b>4 Pinout Specification</b> .....	8
4.1 Pin-Out Diagram (top view).....	8
4.2 Pin Order .....	8
4.3 Pin Description .....	12
4.4 Pin Multiplexing Tables .....	23
4.5 Signal Description.....	28
<b>5 Operating Conditions</b> .....	36
5.1 Absolute Maximum Ratings .....	36
5.2 Recommended Operating Conditions .....	36
5.3 Ripple Voltage Specifications .....	37
5.4 Thermal Resistance.....	37
5.5 DC Electrical Characteristics.....	38
5.5.1 Normal GPIO Specifications (For DIO_xmA) .....	38
5.5.2 Open Drain GPIO Specifications (For DIO_OD) .....	39
5.5.3 DDR3/DDR3L/DDR4/LPDDR3/LPDDR4 SDRAM Specifications .....	40
5.6 Recommended Oscillator Electrical Characteristics.....	41
5.7 Timing Information .....	42
5.7.1 I2C Timing Specification .....	42
5.7.2 EMMC/SD Timing Specification .....	43
5.7.3 NAND Timing Specification .....	48
5.7.4 SPI/C Timing Specification .....	50
5.7.5 SPIFC Timing Specification.....	51
5.7.6 Ethernet Timing Specification.....	52
5.7.7 Audio Timing Specification .....	55
5.7.8 PDM Timing Specification .....	58
5.7.9 UART Timing Specification .....	59
5.8 Power On Config .....	59
5.9 Power On Reset .....	60
5.10 Recommended Power on Sequence .....	61
5.11 Power Consumption.....	62
5.12 Storage and Baking Conditions .....	63
<b>6 Mechanical Dimensions</b> .....	64
<b>7 System</b> .....	65

7.1 Memory Map.....	65
7.2 Power Domain .....	68
7.2.1 Top Level Power Domains.....	69
7.2.2 A55 Power Modes.....	70
7.2.3 EE Top Level Power Modes .....	71
7.2.4 Register Description.....	74
7.3 System Booting .....	79
7.3.1 Overview .....	79
7.3.2 Power-on Flow Chart .....	79
7.4 CPU .....	80
7.5 GPU .....	81
7.6 NPU .....	81
7.6.1 Overview .....	81
7.6.2 Register Description.....	83
7.7 Clock .....	88
7.7.1 Overview .....	88
7.7.2 Clock Trees .....	89
7.7.3 Frequency Calculation .....	97
7.7.4 Clock Gating.....	104
7.7.5 Clock Measure.....	109
7.7.6 Register Description.....	112
7.8 Reset.....	153
7.8.1 Overview .....	153
7.8.2 Register Description.....	153
7.9 GPIO .....	161
7.9.1 Overview .....	161
7.9.2 GPIO Multiplex Function .....	163
7.9.3 Register Description.....	170
7.10 Interrupt Control.....	193
7.10.1 Overview .....	193
7.10.2 Interrupt Source .....	193
7.10.3 GPIO Interrupt .....	199
7.10.4 Register Description.....	201
7.11 Timer .....	204
7.11.1 Overview.....	204
7.11.2 General-Purpose Timer.....	204
7.11.3 Watchdog Timer.....	205
7.11.4 Register Description.....	206
7.12 Crypto.....	215
7.12.1 Overview .....	215

7.12.2 Key Ladder .....	215
7.12.3 RNG .....	215
7.12.4 EFUSE .....	215
<b>8 GE2D</b> .....	216
8.1 Overview .....	216
8.2 Register Description .....	216
<b>9 Video Path</b> .....	242
9.1 Video Input .....	242
9.1.1 Overview .....	242
9.1.2 Register Description.....	243
9.2 Video Output.....	264
9.2.1 Overview .....	264
9.2.2 VPU.....	264
9.2.3 Register Description.....	264
<b>10 Audio Path</b> .....	766
10.1 Audio Input .....	766
10.1.1 Overview .....	766
10.1.2 TDM Input Interface .....	766
10.1.3 SPDIF Input Interface.....	767
10.1.4 PDM .....	768
10.2 Audio Output.....	769
10.2.1 Overview .....	769
10.2.2 TDM Output Interface.....	769
10.2.3 SPDIF Output Interface.....	770
10.2.4 Audio REQ_FRDDR .....	771
10.3 DDR Datapath .....	772
10.3.1 Overview .....	772
10.3.2 Audio TODDR.....	772
10.3.3 Audio FRDDR.....	773
10.4 Audio TORAM .....	773
10.5 Audio Loopback.....	774
10.6 Audio ResampleA.....	774
10.7 Audio ResampleB.....	775
10.8 Audio VAD .....	777
10.9 Audio EQDRC .....	778
10.10 Audio Locker.....	779
10.11 Register Description.....	781
10.11.1 CLK/RESET Registers .....	781
10.11.2 TODDR Registers .....	794
10.11.3 FRDDR Registers .....	805

10.11.4 DDR ARB Registers .....	810
10.11.5 LoopBack Registers .....	810
10.11.6 TDM Registers .....	814
10.11.7 TORAM Registers .....	831
10.11.8 SPDIF Registers .....	833
10.11.9 ResampleA Registers.....	844
10.11.10 ResampleB Registers.....	845
10.11.11 TOACODEC Registers .....	847
10.11.12 TOHDMITX Registers .....	849
10.11.13 TOVAD Registers .....	850
10.11.14 PDM Registers .....	851
10.11.15 LOCKER Registers .....	854
10.11.16 VAD Registers.....	858
10.11.17 EQDRC Registers .....	866
<b>11 AFIFO</b> .....	<b>888</b>
11.1 Register Description.....	888
<b>12 Memory Interface</b> .....	<b>892</b>
12.1 DDR .....	892
12.1.1 Overview .....	892
12.1.2 Register Description.....	893
12.2 NAND .....	957
12.2.1 Overview .....	957
12.2.2 Features .....	957
12.2.3 Descriptor Commands .....	958
12.2.4 Register Description.....	961
12.3 eMMC/SD.....	965
12.3.1 Overview .....	965
12.3.2 Pin Description.....	965
12.3.3 eMMC/SD Mode .....	966
12.3.4 Descriptor .....	966
12.3.5 Register Description.....	969
12.4 Serial Peripheral Interface Communication Controller .....	977
12.4.1 Overview .....	977
12.4.2 Features .....	977
12.4.3 Function.....	977
12.4.4 Register Description.....	979
12.5 Serial Peripheral Interface Flash Controller .....	984
12.5.1 Overview .....	984
12.5.2 Features .....	984
12.5.3 Register Description.....	985

<b>13 I/O Interface</b> .....	995
13.1 Universal Serial Bus.....	995
13.1.1 Overview .....	995
13.1.2 Features .....	995
13.1.3 Register Description.....	995
13.2 PCIE.....	1004
13.3 Ethernet.....	1004
13.3.1 Overview .....	1004
13.3.2 Ethernet MAC .....	1005
13.3.3 Ethernet PHY.....	1006
13.4 Inter-Integrated Circuit (I2C).....	1012
13.4.1 Overview .....	1012
13.4.2 Features .....	1012
13.4.3 Register Description.....	1012
13.5 Universal Asynchronous Receiver And Transmitter .....	1021
13.5.1 Overview .....	1021
13.5.2 Features .....	1021
13.5.3 Functional Description .....	1022
13.5.4 Register Description.....	1022
13.6 Infrared Remote.....	1027
13.6.1 Overview .....	1027
13.6.2 IR Demodulation .....	1027
13.6.3 Legacy IR Control .....	1030
13.6.4 Multi Format IR Control .....	1031
13.6.5 Register Description.....	1032
13.7 Pulse-Width Modulation .....	1046
13.7.1 Overview .....	1046
13.7.2 Register Description.....	1047
13.8 SAR ADC .....	1054
13.8.1 Overview .....	1055
13.8.2 Register Description.....	1055
<b>14 System Interface</b> .....	1063
14.1 JTAG .....	1063
14.1.1 Overview .....	1063
14.1.2 Register Description.....	1063
14.2 Temp Sensor .....	1068
14.2.1 Overview .....	1068
14.2.2 Register Description.....	1069



# 1 About This Document

---

This document is applicable for S905X3 series SoCs, please contact your Amlogic sales representative for details.

**Confidential for Hardkernel!**

## 2 General Description

S905X3 is an advanced application processor designed for hybrid OTT/IP Set Top Box (STB) and high-end media box applications. It integrates a powerful CPU/GPU subsystem, a powerful NPU (Neural Network Processing Unit)<sup>Optional</sup>, a secured 8K video CODEC engine and a best-in-class HDR image processing pipeline with all major peripherals to form the ultimate low power multimedia AP.

The main system CPU is a quad-core ARM Cortex-A55 CPU with unified L3 cache to improve system performance. In addition, the Cortex-A55 CPU includes the NEON SIMD co-processor to improve software media processing capability.

The graphic subsystem consists of two graphic engines and a flexible video/graphic output pipeline. The ARM G31 MP2 GPU handles all OpenGL ES 3.2 Vulkan 1.1 and OpenCL 2.0 graphic programs, while the 2.5D graphics processor handles additional scaling, alpha, rotation and color space conversion operations. Together, the CPU and GPU handle all operating system, networking, user-interface and gaming related tasks. The video output pipeline includes Dolby Vision<sup>optional</sup>, HDR10+, HDR10, PRIME HDR and HLG processing, BT.709/BT.2020/BT.2100 processing, motion adaptive edge enhancing de-interlacing, flexible programmable scaler, and many picture enhancement filters before passing the enhanced image to the video output ports.

Amlogic Video Engine (AVE-10) off-loads the Cortex-A55 CPUs from all video CODEC processing. It includes dedicated hardware video decoder and encoder. AVE-10 is capable of decoding 4Kx2K resolution video at 60fps with complete Trusted Video Path (TVP) for secure applications and supports full formats including MVC, MPEG-1/2/4, VC-1/WMV, AVS, AVS+, AVS2 RealVideo, MJPEG streams, VP9, H.264, H265-10 and also JPEG pictures with no size limitation. The independent encoder is able to encode in JPEG or H.265 up to 1080p at 60fps or H.264 up to 1080p at 30fps.

The processor integrates all standard audio/video input/output interfaces including a HDMI2.1 transmitter with 3D, Dynamic HDR(w/EMP), CEC and HDCP 2.2/2.3, ALLM(Auto Low Latency Mode) support, stereo audio DAC, a CVBS output, multiple TDM, PCM, I2S and SPDIF digital audio input/output interfaces, and 8 channel far-field PDM digital microphone (DMIC) inputs. It also has build-in Voice Activity Detection(VAD)module for ultra-low power operations during system standby.

It also integrates a set of functional blocks for digital TV broadcasting streams. The built-in two demux can process the TV streams from the serial and parallel transport stream input interface, which can connect to external tuner/demodulator.

The processor has rich advanced network and peripheral interfaces, including a 10/100/1000M Ethernet MAC with RGMII, 10/100M Ethernet PHY, a set of multi-PHY for USB2, USB3 and PCIe, and multiple SDIO/SD card controllers, UART, I2C, high-speed SPI and PWMs.

Standard development environment utilizing GNU/GCC Android tool chain is supported. Please contact your AMLOGIC sales representative for more information.

# 3 Features Summary

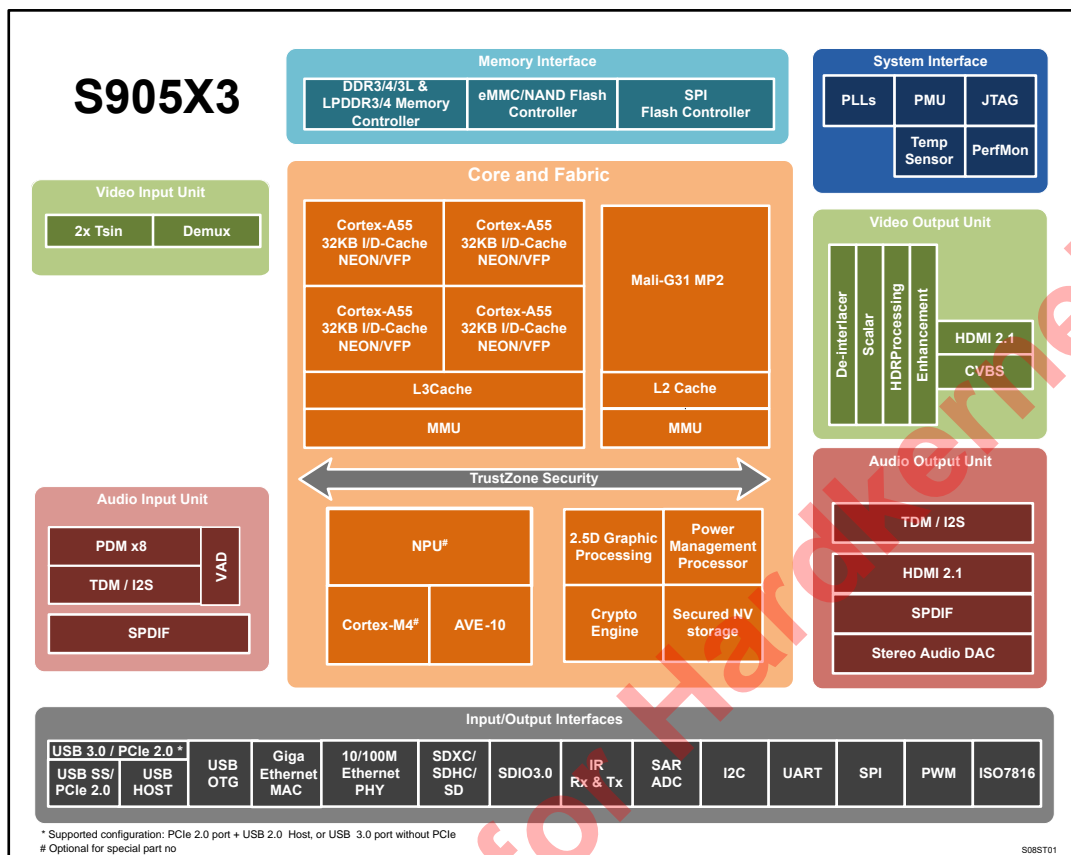

## CPU Sub-system

- Quad core ARM Cortex-A55 CPU
- ARMv8-A architecture with Neon and Crypto extensions
- 8-stage in-order full dual issue pipeline
- Unified system L3 cache
- Build-in Cortex-M4<sup>Optional</sup> core for always on processing
- Build-in Cortex-M3 core for system control processing
- Advanced TrustZone security system
- Application based traffic optimization using internal QoS-based switching fabrics

## NPU<sup>Optional</sup>

- Neural network accelerator (NNA) with programmable engine (PPU) architecture
- 1 NNA with INT8 inference performance up to 1.2Tops
- 1 programmable processing unit (PPU) up to 12.8 GFLOPS FP16 or 6.4 GFLOPS FP32
- 512KB cache

## 3D Graphics Processing Unit

- ARM G31 MP2 GPU
- 4-wide warps, dual texture pipe, 2x 4-wide execution engines (EE)
- Concurrent multi-core processing
- OpenGL ES 3.2, Vulkan 1.1 and OpenCL 2.0 support

## 2.5D Graphics Processor

- Fast bitblt engine with dual inputs and single output
- Programmable raster operations (ROP)
- Programmable polyphase scaling filter
- Supports multiple video formats 4:2:0, 4:2:2 and 4:4:4 and multiple pixel formats (8/16/24/32 bits graphics layer)
- Fast color space conversion
- Advanced anti-flickering filter

## Crypto Engine

- AES/ block cipher with 128/256 bits keys, standard 16 bytes block size and streaming ECB, CBC and CTR modes
- TDES block cipher with ECB and CBC modes supporting 64 bits key for DES and 192 bits key for 3DES
- SM4 block cipher with ECB, CBC, CTR modes
- Hardware crypto key-ladder operation and DVB-CSA for transport stream encryption
- Built-in hardware True Random Number Generator (TRNG), CRC and SHA-1/SHA-2/HMAC SHA engine

## Video/Picture CODEC

- Amlogic Video Engine (AVE) with dedicated hardware decoders and encoders
- Support multi-video decoder up to 4x1080P@60fps
- Supports multiple “secured” video decoding sessions and simultaneous decoding and encoding
- Video/Picture Decoding
  - VP9 Profile-2 up to 8Kx4K@24fps
  - H.265 HEVC MP-10@L5.1 up to 8Kx4K@24fps
  - AVS2-P2 Profile up to 4Kx2K@60fps
  - H.264 AVC HP@L5.1 up to 4Kx2K@30fps
  - MPEG-4 ASP@L5 up to 1080P@60fps (ISO-14496)
  - WMV/VC-1 SP/MP/AP up to 1080P@60fps
  - AVS-P16(AVS+) /AVS-P2 JiZhun Profile up to 1080P@60fps
  - MPEG-2 MP/HL up to 1080P@60fps (ISO-13818)
  - MPEG-1 MP/HL up to 1080P@60fps (ISO-11172)
  - RealVideo 8/9/10 up to 1080P@60fps
  - Multiple language and multiple format sub-title video support
  - MJPEG and JPEG unlimited pixel resolution decoding (ISO/IEC-10918)
  - Supports JPEG thumbnail, scaling, rotation and transition effects
  - Supports \*.mkv, \*.wmv, \*.mpg, \*.mpeg, \*.dat, \*.avi, \*.mov, \*.iso, \*.mp4, \*.rm and \*.jpg file formats
- Video/Picture Encoding
  - Independent JPEG and H.264 encoder with configurable performance/bit-rate
  - JPEG image encoding
  - H.265 video encoding up to 1080P@60fps with low latency
  - H.264 video encoding up to 1080P@30fps with low latency

## 8th Generation Advanced Amlogic TruLife Image Engine

- Supports Dolby Vision<sup>optional</sup>, HDR10+, HDR10, HLG and Technicolor HDR processing
- Motion compensated noise reduction and 3D digital noise reduction for random noise
- Block noise, mosquito noise, spatial noise, contour noise reduction
- Motion compensated and motion adaptive de-interlacer
- Edge interpolation with low angle protection and processing
- 3:2/2:2 pulldown and Video on Film (VOF) detection and processing
- Smart sharpness with SuperScaler technology including de-contouring, de-ring, LTI, CTI, de-jaggy, peaking
- Dynamic non-Linear contrast enhancement
- All dimension multiple regions smart color management including blue/green extension, flesh-tone correction, wider gamut for video
- 2 video planes and 3 graphics planes hardware composer
- Independent HDR re-mapping of video and graphic layer

## Video Input/Output Interface

- Built-in HDMI 2.1 transmitter including both controller and PHY supporting CEC, Dynamic HDR and HDCP 2.2/2.3, 4Kx2K@60 max resolution output
- CVBS 480i/576i standard definition output
- Supports all standard SD/HD/FHD video output formats: 480i/p, 576i/p, 720p, 1080i/p and 4Kx2K

## Audio Decoder and Input/Output

- Supports MP3, AAC, WMA, RM, FLAC, Dolby Audio<sup>Optional</sup>, DTS<sup>Optional</sup> and programmable with 7.1/5.1 down-mixing
- Low-power VAD
- Built-in serial digital audio SPDIF/IEC958 input/output, and PCM input/output, SPDIF supports 192KHz 16/24/32bit stereo
- 3 built-in TDM/PCM/I2S ports with TDM/PCM mode up to 384kHz x 32bits x 16ch or 96kHz x 32-bits x 32ch and I2S mode up to 384kHz x 32bits x 16ch
- Digital microphone PDM input with programmable CIC, LPF; HPF, support up to 8 DMICs
- Built-in stereo audio DAC
- Supports concurrent dual audio stereo channel output with combination of analog+PCM or I2S+PCM

## Memory and Storage Interface

- 32-bit DRAM memory interface with dual ranks and max 4GB total address space
- Compatible with JEDEC standard DDR3-2133 /DDR3L-2133 /DDR4-3200 /LPDDR3-2133 /LPDDR4-3200 SDRAM
- Supports SLC/MLC/TLC NAND Flash with 60-bit ECC, compatible to Toshiba toggle mode in addition to ONFI 2.2
- SDSC/SDHC/SDXC card and SDIO interface with 1-bit and 4-bit data bus width supporting spec version 2.x/3.x/4.x DS/HS modes up to UHS-I SDR104
- eMMC and MMC card interface with 1/4/8-bit data bus width fully supporting spec version 5.0 HS400
- Supports serial 1, 2 or 4-bit NOR Flash via SPI interface
- Built-in 4k bits One-Time-Programming memory for key storage

## Network

- Integrated IEEE 802.3 10/100/1000M Ethernet MAC with RGMII interface
- Integrate 10/100M Ethernet PHY interface
- WiFi/IEEE802.11; Bluetooth supporting via PCIE/SDIO/USB/UART/PCM
- Network interface optimized for mixed WIFI and BT traffic

## Digital Television Interface

- 1 serial and 1 parallel/serial transport stream (TS) input interface with built-in demux processor for connecting to external digital TV tuner/demodulator
- Built-in PWM, I2C and SPI interfaces to control tuner and demodulator
- Integrated ISO 7816 smart card controller

## Integrated I/O Controllers and Interfaces

- One USB XHCI OTG 2.0 port
- One USB SS and PCIE 2.0 combo port up to 5Gbps, which supports 2 configurations:
  - 1 USB 2.0 Host + 1 PCIe
  - 1 USB3.0 (No PCIe)
- Multiple PWM, UART, I2C and SPI interface with slave select
- Programmable IR remote input/output controllers
- Built-in 10bit SAR ADC with 4 input channels
- A set of General Purpose IOs with built-in pull up and pull down

## System, Peripherals and Misc. Interfaces

- Integrated general purpose timers, counters, DMA controllers
- 24 MHz crystal input
- Embedded debug interface using ICE/JTAG
- Integrated Power On Reset(POR) module

## Power Management

- Multiple internal power domains controlled by software
- Multiple sleep modes for CPU, system, DRAM, etc.
- Multiple internal PLLs for DVFS operation
- Multi-voltage I/O design for 1.8V and 3.3V
- Power management auxiliary processor in a dedicated always-on (AO) power domain that can communicate with an external PMIC

## Security

- Trustzone based Trusted Execution Environment (TEE)
- Secured boot, encrypted OTP, encrypted DRAM with memory integrity checker, hardware key ladder and internal control buses and storage
- Separated secure/non-secure Entropy true RNG
- Pre-region/ID memory security control and electric fence
- Hardware based Trusted Video Path (TVP) , video watermarking and secured contents (needs SecureOS software)
- Secured IO and secured clock

**Package**

- FCBGA, 14mmx14mm,RoHS compliant

Confidential for Hardkernel!

# 4 Pinout Specification

## 4.1 Pin-Out Diagram (top view)

Figure 4-1 Pinout Diagram(topview)

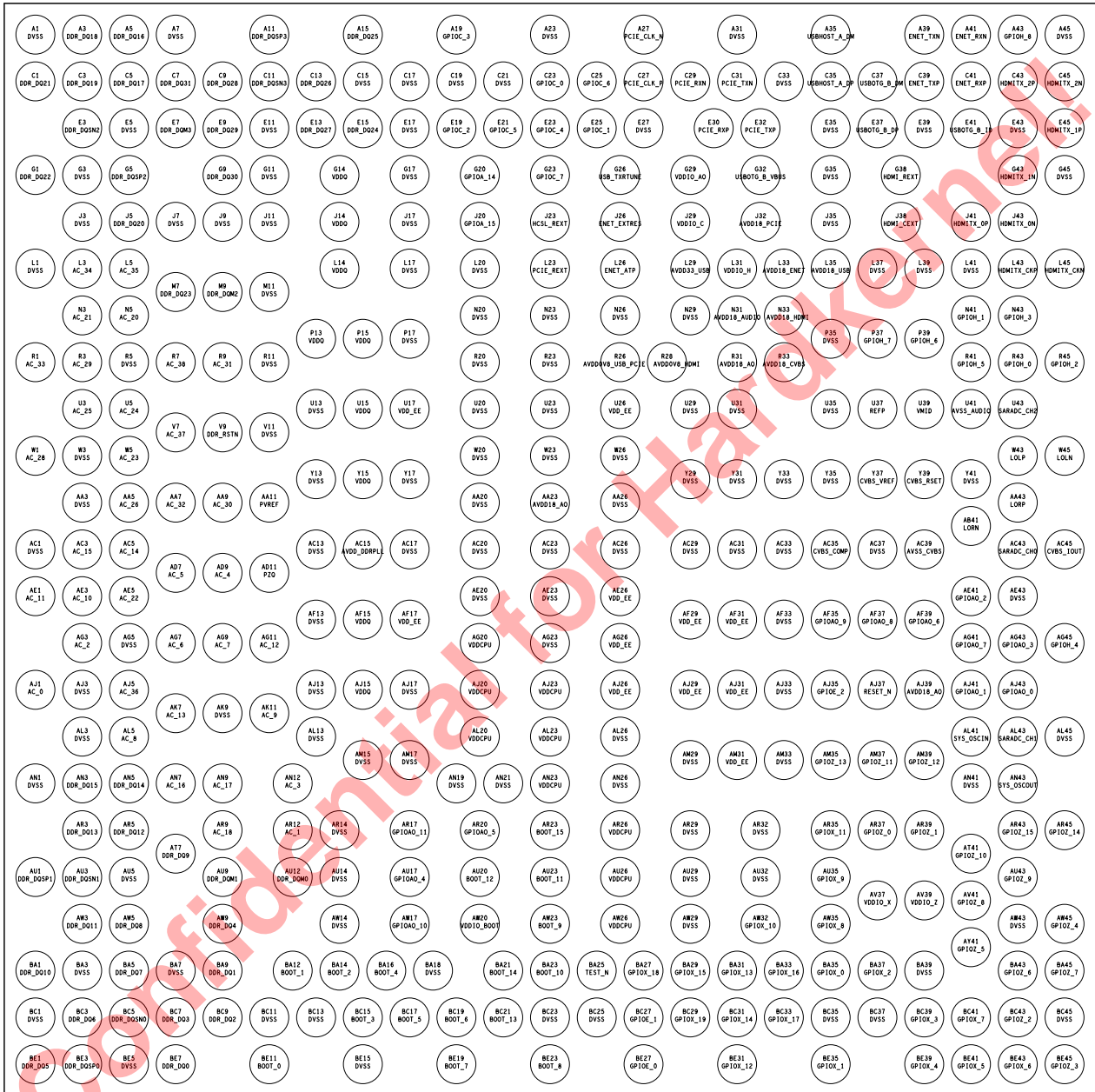

## 4.2 Pin Order

BALL #	NET NAME	BALL #	NET NAME	BALL #	NET NAME
A1	DVSS	A7	DVSS	A19	GPIOC_3
A3	DDR_DQ18	A11	DDR_DQSP3	A23	DVSS
A5	DDR_DQ16	A15	DDR_DQ25	A27	PCIE_CLK_n



BALL #	NET NAME	BALL #	NET NAME	BALL #	NET NAME
A31	DVSS	E17	DVSS	J20	GPIOA_15
A35	USBHOST_A_DM	E19	GPIOC_2	J23	HCSL_REXT
A39	ENET_TXN	E21	GPIOC_5	J26	ENET_EXTRES
A41	ENET_RXN	E23	GPIOC_4	J29	VDDIO_C
A43	GPIOH_8	E25	GPIOC_1	J32	AVDD18_PCIE
A45	DVSS	E27	DVSS	J35	DVSS
C1	DDR_DQ21	E30	PCIE_RXP	J38	HDMI_CEXT
C3	DDR_DQ19	E32	PCIE_TXP	J41	HDMITX_0P
C5	DDR_DQ17	E35	DVSS	J43	HDMITX_0N
C7	DDR_DQ31	E37	USBOTG_B_DP	L1	DVSS
C9	DDR_DQ28	E39	DVSS	L3	AC_34
C11	DDR_DQSN3	E41	USBOTG_B_ID	L5	AC_35
C13	DDR_DQ26	E43	DVSS	L14	VDDQ
C15	DVSS	E45	HDMITX_1P	L17	DVSS
C17	DVSS	G1	DDR_DQ22	L20	DVSS
C19	DVSS	G3	DVSS	L23	PCIE_REXT
C21	DVSS	G5	DDR_DQSP2	L26	ENET_ATP
C23	GPIOC_0	G9	DDR_DQ30	L29	AVDD33_USB
C25	GPIOC_6	G11	DVSS	L31	VDDIO_H
C27	PCIE_CLK_p	G14	VDDQ	L33	AVDD18_ENET
C29	PCIE_RXN	G17	DVSS	L35	AVDD18_USB
C31	PCIE_TXN	G20	GPIOA_14	L37	DVSS
C33	DVSS	G23	GPIOC_7	L39	DVSS
C35	USBHOST_A_DP	G26	USB_TXRTUNE	L41	DVSS
C37	USBOTG_B_DM	G29	VDDIO_AO	L43	HDMITX_CKP
C39	ENET_TXP	G32	USBOTG_B_VBUS	L45	HDMITX_CKN
C41	ENET_RXP	G35	DVSS	M7	DDR_DQ23
C43	HDMITX_2P	G38	HDMI_REXT	M9	DDR_DQM2
C45	HDMITX_2N	G43	HDMITX_1N	M11	DVSS
E3	DDR_DQSN2	G45	DVSS	N3	AC_21
E5	DVSS	J3	DVSS	N5	AC_20
E7	DDR_DQM3	J5	DDR_DQ20	N20	DVSS
E9	DDR_DQ29	J7	DVSS	N23	DVSS
E11	DVSS	J9	DVSS	N26	DVSS
E13	DDR_DQ27	J11	DVSS	N29	DVSS
E15	DDR_DQ24	J14	VDDQ	N31	AVDD18_AUDIO
		J17	DVSS		

BALL #	NET NAME	BALL #	NET NAME	BALL #	NET NAME
N33	AVDD18_HDMI	U41	AVSS_AUDIO	AC15	AVDD_DDRPLL
N41	GPIOH_1	U43	SARADC_CH2	AC17	DVSS
N43	GPIOH_3	V7	AC_37	AC20	DVSS
P13	VDDQ	V9	DDR_RSTn	AC23	DVSS
P15	VDDQ	V11	DVSS	AC26	DVSS
P17	DVSS	W1	AC_28	AC29	DVSS
P35	DVSS	W3	DVSS	AC31	DVSS
P37	GPIOH_7	W5	AC_23	AC33	DVSS
P39	GPIOH_6	W20	DVSS	AC35	CVBS_COMP
R1	AC_33	W23	DVSS	AC37	DVSS
R3	AC_29	W26	DVSS	AC39	AVSS_CVBS
R5	DVSS	W43	LOLP	AC43	SARADC_CH0
R7	AC_38	W45	LOLN	AC45	CVBS_IOUT
R9	AC_31	Y13	DVSS	AD7	AC_5
R11	DVSS	Y15	VDDQ	AD9	AC_4
R20	DVSS	Y17	DVSS	AD11	PZQ
R23	DVSS	Y29	DVSS	AE1	AC_11
R26	AVDD0V8_USB_PCIE	Y31	DVSS	AE3	AC_10
R28	AVDD0V8_HDMI	Y33	DVSS	AE5	AC_22
R31	AVDD18_AO	Y35	DVSS	AE20	DVSS
R33	AVDD18_CVBS	Y37	CVBS_VREF	AE23	DVSS
R41	GPIOH_5	Y39	CVBS_RSET	AE26	VDD_EE
R43	GPIOH_0	Y41	DVSS	AE41	GPIOAO_2
R45	GPIOH_2	AA3	DVSS	AE43	DVSS
U3	AC_25	AA5	AC_26	AF13	DVSS
U5	AC_24	AA7	AC_32	AF15	VDDQ
U13	DVSS	AA9	AC_30	AF17	VDD_EE
U15	VDDQ	AA11	PVREF	AF29	VDD_EE
U17	VDD_EE	AA20	DVSS	AF31	VDD_EE
U20	DVSS	AA23	AVDD18_AO	AF33	DVSS
U23	DVSS	AA26	DVSS	AF35	GPIOAO_9
U26	VDD_EE	AA43	LORP	AF37	GPIOAO_8
U29	DVSS	AB41	LORN	AF39	GPIOAO_6
U31	DVSS	AC1	DVSS	AG3	AC_2
U35	DVSS	AC3	AC_15	AG5	DVSS
U37	REFP	AC5	AC_14	AG7	AC_6
U39	VMID	AC13	DVSS	AG9	AC_7

BALL #	NET NAME	BALL #	NET NAME	BALL #	NET NAME
AG11	AC_12	AM17	DVSS	AT41	GPIOZ_10
AG20	VDDCPU	AM29	DVSS	AU1	DDR_DQSP1
AG23	DVSS	AM31	VDD_EE	AU3	DDR_DQSN1
AG26	VDD_EE	AM33	DVSS	AU5	DVSS
AG41	GPIOAO_7	AM35	GPIOZ_13	AU9	DDR_DQM1
AG43	GPIOAO_3	AM37	GPIOZ_11	AU12	DDR_DQM0
AG45	GPIOH_4	AM39	GPIOZ_12	AU14	DVSS
AJ1	AC_0	AN1	DVSS	AU17	GPIOAO_4
AJ3	DVSS	AN3	DDR_DQ15	AU20	BOOT_12
AJ5	AC_36	AN5	DDR_DQ14	AU23	BOOT_11
AJ13	DVSS	AN7	AC_16	AU26	VDDCPU
AJ15	VDDQ	AN9	AC_17	AU29	DVSS
AJ17	DVSS	AN12	AC_3	AU32	DVSS
AJ20	VDDCPU	AN19	DVSS	AU35	GPIOX_9
AJ23	VDDCPU	AN21	DVSS	AU43	GPIOZ_9
AJ26	VDD_EE	AN23	VDDCPU	AV37	VDDIO_X
AJ29	VDD_EE	AN26	DVSS	AV39	VDDIO_Z
AJ31	VDD_EE	AN41	DVSS	AV41	GPIOZ_8
AJ33	DVSS	AN43	SYS_OSCOUT	AW3	DDR_DQ11
AJ35	GPIOE_2	AR3	DDR_DQ13	AW5	DDR_DQ8
AJ37	RESET_N	AR5	DDR_DQ12	AW9	DDR_DQ4
AJ39	AVDD18_AO	AR9	AC_18	AW14	DVSS
AJ41	GPIOAO_1	AR12	AC_1	AW17	GPIOAO_10
AJ43	GPIOAO_0	AR14	DVSS	AW20	VDDIO_BOOT
AK7	AC_13	AR17	GPIOAO_11	AW23	BOOT_9
AK9	DVSS	AR20	GPIOAO_5	AW26	VDDCPU
AK11	AC_9	AR23	BOOT_15	AW29	DVSS
AL3	DVSS	AR26	VDDCPU	AW32	GPIOX_10
AL5	AC_8	AR29	DVSS	AW35	GPIOX_8
AL13	DVSS	AR32	DVSS	AW43	DVSS
AL20	VDDCPU	AR35	GPIOX_11	AW45	GPIOZ_4
AL23	VDDCPU	AR37	GPIOZ_0	AY41	GPIOZ_5
AL26	DVSS	AR39	GPIOZ_1	BA1	DDR_DQ10
AL41	SYS_OSCIN	AR43	GPIOZ_15	BA3	DVSS
AL43	SARADC_CH1	AR45	GPIOZ_14	BA5	DDR_DQ7
AL45	DVSS	AT7	DDR_DQ9	BA7	DVSS
AM15	DVSS				

BALL #	NET NAME	BALL #	NET NAME	BALL #	NET NAME
BA9	DDR_DQ1	BC5	DDR_DQSN0	BC43	GPIOX_2
BA12	BOOT_1	BC7	DDR_DQ3	BC45	DVSS
BA14	BOOT_2	BC9	DDR_DQ2	BE1	DDR_DQ5
BA16	BOOT_4	BC11	DVSS	BE3	DDR_DQSP0
BA18	DVSS	BC13	DVSS	BE5	DVSS
BA21	BOOT_14	BC15	BOOT_3	BE7	DDR_DQ0
BA23	BOOT_10	BC17	BOOT_5	BE11	BOOT_0
BA25	TEST_N	BC19	BOOT_6	BE15	DVSS
BA27	GPIOX_18	BC21	BOOT_13	BE19	BOOT_7
BA29	GPIOX_15	BC23	DVSS	BE23	BOOT_8
BA31	GPIOX_13	BC25	DVSS	BE27	GPIOE_0
BA33	GPIOX_16	BC27	GPIOE_1	BE31	GPIOX_12
BA35	GPIOX_0	BC29	GPIOX_19	BE35	GPIOX_1
BA37	GPIOX_2	BC31	GPIOX_14	BE39	GPIOX_4
BA39	DVSS	BC33	GPIOX_17	BE41	GPIOX_5
BA43	GPIOZ_6	BC35	DVSS	BE43	GPIOX_6
BA45	GPIOZ_7	BC37	DVSS	BE45	GPIOZ_3
BC1	DVSS	BC39	GPIOX_3		
BC3	DDR_DQ6	BC41	GPIOX_7		

### 4.3 Pin Description

The SoC application processor pin assignment is described in the following table.

Net Name	Type	Default Pull UP/ DN	Description	Power Domain	If Unused
<b>GPIOZ</b> -Refer to <a href="#">Table 4-1</a> for functional multiplex information.					
GPIOZ_0	DIO	Up	General purpose input/output bank Z signal 0	VDDIO_Z	NC
GPIOZ_1	DIO	Up	General purpose input/output bank Z signal 1	VDDIO_Z	NC
GPIOZ_2	DIO	Up	General purpose input/output bank Z signal 2	VDDIO_Z	NC
GPIOZ_3	DIO	Up	General purpose input/output bank Z signal 3	VDDIO_Z	NC
GPIOZ_4	DIO	Up	General purpose input/output bank Z signal 4	VDDIO_Z	NC
GPIOZ_5	DIO	Up	General purpose input/output bank Z signal 5	VDDIO_Z	NC
GPIOZ_6	DIO	Up	General purpose input/output bank Z signal 6	VDDIO_Z	NC
GPIOZ_7	DIO	Up	General purpose input/output bank Z signal 7	VDDIO_Z	NC
GPIOZ_8	DIO	Up	General purpose input/output bank Z signal 8	VDDIO_Z	NC
GPIOZ_9	DIO	Down	General purpose input/output bank Z signal 9	VDDIO_Z	NC

Net Name	Type	Default Pull UP/DN	Description	Power Domain	If Unused
GPIOZ_10	DIO	Down	General purpose input/output bank Z signal 10	VDDIO_Z	NC
GPIOZ_11	DIO	Down	General purpose input/output bank Z signal 11	VDDIO_Z	NC
GPIOZ_12	DIO	Down	General purpose input/output bank Z signal 12	VDDIO_Z	NC
GPIOZ_13	DIO	Down	General purpose input/output bank Z signal 13	VDDIO_Z	NC
GPIOZ_14	OD 5V	Z	General purpose input/output bank Z signal 14	VDDIO_Z	NC
GPIOZ_15	OD 5V	Z	General purpose input/output bank Z signal 15	VDDIO_Z	NC
VDDIO_Z	P	-	Power supply for GPIO bank Z	-	NC
<b>GPIOA</b> - Refer to <a href="#">Table 4-2</a> for functional multiplex information.					
GPIOA_14	DIO	Up	General purpose input/output bank A signal 14	VDDIO_AO	NC
GPIOA_15	DIO	Up	General purpose input/output bank A signal 15	VDDIO_AO	NC
<b>BOOT</b> -Refer to <a href="#">Table 4-3</a> for functional multiplex information.					
BOOT_0	DIO	UP	General purpose input/output bank BOOT signal 0	VDDIO_BOOT	NC
BOOT_1	DIO	UP	General purpose input/output bank BOOT signal 1	VDDIO_BOOT	NC
BOOT_2	DIO	UP	General purpose input/output bank BOOT signal 2	VDDIO_BOOT	NC
BOOT_3	DIO	UP	General purpose input/output bank BOOT signal 3	VDDIO_BOOT	NC
BOOT_4	DIO	UP	General purpose input/output bank BOOT signal 4	VDDIO_BOOT	NC
BOOT_5	DIO	UP	General purpose input/output bank BOOT signal 5	VDDIO_BOOT	NC
BOOT_6	DIO	UP	General purpose input/output bank BOOT signal 6	VDDIO_BOOT	NC
BOOT_7	DIO	UP	General purpose input/output bank BOOT signal 7	VDDIO_BOOT	NC
BOOT_8	DIO	UP	General purpose input/output bank BOOT signal 8	VDDIO_BOOT	NC
BOOT_9	DIO	UP	General purpose input/output bank BOOT signal 9	VDDIO_BOOT	NC
BOOT_10	DIO	UP	General purpose input/output bank BOOT signal 10	VDDIO_BOOT	NC
BOOT_11	DIO	UP	General purpose input/output bank BOOT signal 11	VDDIO_BOOT	NC
BOOT_12	DIO	DOWN	General purpose input/output bank BOOT signal 12	VDDIO_BOOT	NC

Net Name	Type	Default Pull UP/DN	Description	Power Domain	If Unused
BOOT_13	DIO	DOWN	General purpose input/output bank BOOT signal 13	VDDIO_BOOT	NC
BOOT_14	DIO	UP	General purpose input/output bank BOOT signal 14	VDDIO_BOOT	NC
BOOT_15	DIO	UP	General purpose input/output bank BOOT signal 15	VDDIO_BOOT	NC
VDDIO_BOOT	P	-	Power supply for GPIO bank BOOT	-	To VDDIO_BOOT
<b>GPIOC</b> - Refer to <a href="#">Table 4-4</a> for functional multiplex information.					
GPIOC_0	DIO	UP	General purpose input/output bank C signal 0	VDDIO_C	NC
GPIOC_1	DIO	UP	General purpose input/output bank C signal 1	VDDIO_C	NC
GPIOC_2	DIO	UP	General purpose input/output bank C signal 2	VDDIO_C	NC
GPIOC_3	DIO	UP	General purpose input/output bank C signal 3	VDDIO_C	NC
GPIOC_4	DIO	UP	General purpose input/output bank C signal 4	VDDIO_C	NC
GPIOC_5	DIO	UP	General purpose input/output bank C signal 5	VDDIO_C	NC
GPIOC_6	DIO	UP	General purpose input/output bank C signal 6	VDDIO_C	NC
GPIOC_7	OD 5V	Z	General purpose input/output bank C signal 7	VDDIO_C	NC
VDDIO_C	P	-	Power supply for GPIO bank C	-	NC
<b>GPIOX</b> - Refer to <a href="#">Table 4-5</a> for functional multiplex information.					
GPIOX_0	DIO	Up	General purpose input/output bank X signal 0	VDDIO_X	NC
GPIOX_1	DIO	Up	General purpose input/output bank X signal 1	VDDIO_X	NC
GPIOX_2	DIO	Up	General purpose input/output bank X signal 2	VDDIO_X	NC
GPIOX_3	DIO	Up	General purpose input/output bank X signal 3	VDDIO_X	NC
GPIOX_4	DIO	Up	General purpose input/output bank X signal 4	VDDIO_X	NC
GPIOX_5	DIO	Up	General purpose input/output bank X signal 5	VDDIO_X	NC
GPIOX_6	DIO	Down	General purpose input/output bank X signal 6	VDDIO_X	NC
GPIOX_7	DIO	Up	General purpose input/output bank X signal 7	VDDIO_X	NC
GPIOX_8	DIO	Up	General purpose input/output bank X signal 8	VDDIO_X	NC
GPIOX_9	DIO	Up	General purpose input/output bank X signal 9	VDDIO_X	NC
GPIOX_10	DIO	Up	General purpose input/output bank X signal 10	VDDIO_X	NC
GPIOX_11	DIO	Up	General purpose input/output bank X signal 11	VDDIO_X	NC
GPIOX_12	DIO	Up	General purpose input/output bank X signal 12	VDDIO_X	NC
GPIOX_13	DIO	Up	General purpose input/output bank X signal 13	VDDIO_X	NC
GPIOX_14	DIO	Up	General purpose input/output bank X signal 14	VDDIO_X	NC

Net Name	Type	Default Pull UP/DN	Description	Power Domain	If Unused
GPIOX_15	DIO	Up	General purpose input/output bank X signal 15	VDDIO_X	NC
GPIOX_16	DIO	Up	General purpose input/output bank X signal 16	VDDIO_X	NC
GPIOX_17	DIO	Down	General purpose input/output bank X signal 17	VDDIO_X	NC
GPIOX_18	DIO	Up	General purpose input/output bank X signal 18	VDDIO_X	NC
GPIOX_19	DIO	Z	General purpose input/output bank X signal 19	VDDIO_X	NC
VDDIO_X	P	-	Power supply for GPIO bank X	-	NC
<b>GPIOH</b> - Refer to <a href="#">Table 4-6</a> for functional multiplex information.					
GPIOH_0	OD5V	Z	General purpose input/output bank H signal 0	VDDIO_H	NC
GPIOH_1	OD5V	Z	General purpose input/output bank H signal 1	VDDIO_H	NC
GPIOH_2	OD5V	Z	General purpose input/output bank H signal 2	VDDIO_H	NC
GPIOH_3	OD5V	Z	General purpose input/output bank H signal 3	VDDIO_H	NC
GPIOH_4	DIO	DOWN	General purpose input/output bank H signal 4	VDDIO_H	NC
GPIOH_5	DIO	DOWN	General purpose input/output bank H signal 5	VDDIO_H	NC
GPIOH_6	DIO	DOWN	General purpose input/output bank H signal 6	VDDIO_H	NC
GPIOH_7	DIO	DOWN	General purpose input/output bank H signal 7	VDDIO_H	NC
GPIOH_8	OD5V	Z	General purpose input/output bank H signal 8	VDDIO_H	NC
VDDIO_H	P	-	Power supply for GPIO bank H	-	NC
<b>GPIOAO</b> -Refer to <a href="#">Table 4-7</a> for functional multiplex information.					
GPIOAO_0	DIO	Up	General purpose input/output bank AO signal 0	VDDIO_AO	NC
GPIOAO_1	DIO	Up	General purpose input/output bank AO signal 1	VDDIO_AO	NC
GPIOAO_2	DIO	Down	General purpose input/output bank AO signal 2	VDDIO_AO	NC
GPIOAO_3	DIO	Up	General purpose input/output bank AO signal 3	VDDIO_AO	NC
GPIOAO_4	DIO	Down	General purpose input/output bank AO signal 4	VDDIO_AO	NC
GPIOAO_5	DIO	Up	General purpose input/output bank AO signal 5	VDDIO_AO	NC
GPIOAO_6	DIO	Down	General purpose input/output bank AO signal 6	VDDIO_AO	NC
GPIOAO_7	DIO	Up	General purpose input/output bank AO signal 7	VDDIO_AO	NC
GPIOAO_8	DIO	Up	General purpose input/output bank AO signal 8	VDDIO_AO	NC
GPIOAO_9	DIO	Down	General purpose input/output bank AO signal 9	VDDIO_AO	NC

Net Name	Type	Default Pull UP/ DN	Description	Power Domain	If Unused
GPIOAO_10	DIO	Up	General purpose input/output bank AO signal 10	VDDIO_AO	NC
GPIOAO_11	DIO	Down	General purpose input/output bank AO signal 11	VDDIO_AO	NC
VDDIO_AO	P	-	Power supply for GPIO bank AO and GPIO bank A	VDDIO_AO	To 3.3V
TEST_N	DIO	UP	SOC test pin and general purpose input/output bank AO signal 12. Should be pulled up during normal power-on.	VDDIO_AO	NC
RESET_N	Input	DOWN	System reset input	VDDIO_AO	To GND by 1nF capacitor
<b>GPIOE</b> - Refer to <a href="#">Table 4-8</a> for functional multiplex information.					
GPIOE_0	DIO	Z	General purpose input/output bank E signal 0	VDD18_AO	NC
GPIOE_1	DIO	Z	General purpose input/output bank E signal 1	VDD18_AO	NC
GPIOE_2	DIO	Z	General purpose input/output bank E signal 2	VDD18_AO	NC
VDD18_AO	P	-	Power supply for GPIO bank E, IOVREF	-	To VDD18_AO
<b>SARADC</b>					
SARADC_CH0	AI	-	ADC channel 0 input	AVDD18_SARADC	NC
SARADC_CH1	AI	-	ADC channel 1 input	AVDD18_SARADC	NC
SARADC_CH2	AI	-	ADC channel 2 input	AVDD18_SARADC	NC
AVDD18_SARADC	P	-	Analog power supply for SARADC	-	To 1.8V
<b>CVBS OUT</b>					
CVBS_COMP	A	-	CVBS external compensation capacitor connection	AVDD18_CVBS	NC
CVBS_IOUT	AO	-	Video DAC output	AVDD18_CVBS	NC
CVBS_RSET	A	-	CVBS output strength setting resistor	AVDD18_CVBS	NC
CVBS_VREF	A	-	CVBS reference voltage filter cap	AVDD18_CVBS	NC
AVDD18_CVBS	P	-	1.8 V Analog power supply for CVBS_OUT	-	To 1.8V
<b>HDMI TX &amp; eRAC RX</b>					
HDMITX_0P	AO	-	HDMI TMDS data0 positive output	3.3V	NC
HDMITX_0N	AO	-	HDMI TMDS data0 negative output	3.3V	NC
HDMITX_1P	AO	-	HDMI TMDS data1 positive output	3.3V	NC
HDMITX_1N	AO	-	HDMI TMDS data1 negative output	3.3V	NC



Net Name	Type	Default Pull UP/DN	Description	Power Domain	If Unused
HDMITX_2P	AO	-	HDMI TMDS data2 positive output	3.3V	NC
HDMITX_2N	AO	-	HDMI TMDS data2 negative output	3.3V	NC
HDMITX_CKP	AO	-	HDMI TMDS clock positive output	3.3V	NC
HDMITX_CKN	AO	-	HDMI TMDS clock negative output	3.3V	NC
HDMI_REXT	A	-	HDMI output strength setting resistor	3.3V	NC
HDMI_CEXT	A	-	HDMI TX external filter cap	3.3V	NC
AVDD18_HDMI	P	-	Analog power supply 1.8V for HDMI	-	To 1.8V
AVDD0V8_HDMI	P	-	Power supply 0.8V for HDMI	-	To VDD_EE
<b>DRAM-</b> Refer to <a href="#">Table 4-9</a> for functional multiplex information.					
AC_0	DO	-	DDR PHY address/command/control signal bit 0	VDDQ	NC
AC_1	DO	-	DDR PHY address/command/control signal bit 1	VDDQ	NC
AC_2	DO	-	DDR PHY address/command/control signal bit 2	VDDQ	NC
AC_3	DO	-	DDR PHY address/command/control signal bit 3	VDDQ	NC
AC_4	DO	-	DDR PHY address/command/control signal bit 4	VDDQ	NC
AC_5	DO	-	DDR PHY address/command/control signal bit 5	VDDQ	NC
AC_6	DO	-	DDR PHY address/command/control signal bit 6	VDDQ	NC
AC_7	DO	-	DDR PHY address/command/control signal bit 7	VDDQ	NC
AC_8	DO	-	DDR PHY address/command/control signal bit 8	VDDQ	NC
AC_9	DO	-	DDR PHY address/command/control signal bit 9	VDDQ	NC
AC_10	DO	-	DDR PHY address/command/control signal bit 10	VDDQ	NC
AC_11	DO	-	DDR PHY address/command/control signal bit 11	VDDQ	NC
AC_12	DO	-	DDR PHY address/command/control signal bit 12	VDDQ	NC
AC_13	DO	-	DDR PHY address/command/control signal bit 13	VDDQ	NC
AC_14	DO	-	DDR PHY address/command/control signal bit 14	VDDQ	NC
AC_15	DO	-	DDR PHY address/command/control signal bit 15	VDDQ	NC

Net Name	Type	Default Pull UP/DN	Description	Power Domain	If Unused
AC_16	DO	-	DDR PHY address/command/control signal bit 16	VDDQ	NC
AC_17	DO	-	DDR PHY address/command/control signal bit 17	VDDQ	NC
AC_18	DO	-	DDR PHY address/command/control signal bit 18	VDDQ	NC
AC_20	DO	-	DDR PHY address/command/control signal bit 20	VDDQ	NC
AC_21	DO	-	DDR PHY address/command/control signal bit 21	VDDQ	NC
AC_22	DO	-	DDR PHY address/command/control signal bit 22	VDDQ	NC
AC_23	DO	-	DDR PHY address/command/control signal bit 23	VDDQ	NC
AC_24	DO	-	DDR PHY address/command/control signal bit 24	VDDQ	NC
AC_25	DO	-	DDR PHY address/command/control signal bit 25	VDDQ	NC
AC_26	DO	-	DDR PHY address/command/control signal bit 26	VDDQ	NC
AC_28	DO	-	DDR PHY address/command/control signal bit 28	VDDQ	NC
AC_29	DO	-	DDR PHY address/command/control signal bit 29	VDDQ	NC
AC_30	DO	-	DDR PHY address/command/control signal bit 30	VDDQ	NC
AC_31	DO	-	DDR PHY address/command/control signal bit 31	VDDQ	NC
AC_32	DO	-	DDR PHY address/command/control signal bit 32	VDDQ	NC
AC_33	DO	-	DDR PHY address/command/control signal bit 33	VDDQ	NC
AC_34	DO	-	DDR PHY address/command/control signal bit 34	VDDQ	NC
AC_35	DO	-	DDR PHY address/command/control signal bit 35	VDDQ	NC
AC_36	DO	-	DDR PHY address/command/control signal bit 36	VDDQ	NC
AC_37	DO	-	DDR PHY address/command/control signal bit 37	VDDQ	NC
AC_38	DO	-	DDR PHY address/command/control signal bit 38	VDDQ	NC
DDR_RSTn	DO	-	DDR3/DDR4/LPDDR4 RSTn	VDDQ	NC
DDR_DQ0	DIO	-	DRAM data bus bit 0	VDDQ	To DRAM
DDR_DQ1	DIO	-	DRAM data bus bit 1	VDDQ	To DRAM

Net Name	Type	Default Pull UP/ DN	Description	Power Domain	If Unused
DDR_DQ2	DIO	-	DRAM data bus bit 2	VDDQ	To DRAM
DDR_DQ3	DIO	-	DRAM data bus bit 3	VDDQ	To DRAM
DDR_DQ4	DIO	-	DRAM data bus bit 4	VDDQ	To DRAM
DDR_DQ5	DIO	-	DRAM data bus bit 5	VDDQ	To DRAM
DDR_DQ6	DIO	-	DRAM data bus bit 6	VDDQ	To DRAM
DDR_DQ7	DIO	-	DRAM data bus bit 7	VDDQ	To DRAM
DDR_DQ8	DIO	-	DRAM data bus bit 8	VDDQ	To DRAM
DDR_DQ9	DIO	-	DRAM data bus bit 9	VDDQ	To DRAM
DDR_DQ10	DIO	-	DRAM data bus bit 10	VDDQ	To DRAM
DDR_DQ11	DIO	-	DRAM data bus bit 11	VDDQ	To DRAM
DDR_DQ12	DIO	-	DRAM data bus bit 12	VDDQ	To DRAM
DDR_DQ13	DIO	-	DRAM data bus bit 13	VDDQ	To DRAM
DDR_DQ14	DIO	-	DRAM data bus bit 14	VDDQ	To DRAM
DDR_DQ15	DIO	-	DRAM data bus bit 15	VDDQ	To DRAM
DDR_DQ16	DIO	-	DRAM data bus bit 16	VDDQ	NC
DDR_DQ17	DIO	-	DRAM data bus bit 17	VDDQ	NC
DDR_DQ18	DIO	-	DRAM data bus bit 18	VDDQ	NC
DDR_DQ19	DIO	-	DRAM data bus bit 19	VDDQ	NC
DDR_DQ20	DIO	-	DRAM data bus bit 20	VDDQ	NC
DDR_DQ21	DIO	-	DRAM data bus bit 21	VDDQ	NC
DDR_DQ22	DIO	-	DRAM data bus bit 22	VDDQ	NC
DDR_DQ23	DIO	-	DRAM data bus bit 23	VDDQ	NC
DDR_DQ24	DIO	-	DRAM data bus bit 24	VDDQ	NC
DDR_DQ25	DIO	-	DRAM data bus bit 25	VDDQ	NC
DDR_DQ26	DIO	-	DRAM data bus bit 26	VDDQ	NC
DDR_DQ27	DIO	-	DRAM data bus bit 27	VDDQ	NC
DDR_DQ28	DIO	-	DRAM data bus bit 28	VDDQ	NC
DDR_DQ29	DIO	-	DRAM data bus bit 29	VDDQ	NC

Net Name	Type	Default Pull UP/ DN	Description	Power Domain	If Unused
DDR_DQ30	DIO	-	DRAM data bus bit 30	VDDQ	NC
DDR_DQ31	DIO	-	DRAM data bus bit 31	VDDQ	NC
DDR_DQM0	DIO	-	DRAM data mask 0	VDDQ	To DRAM
DDR_DQM1	DIO	-	DRAM data mask 1	VDDQ	To DRAM
DDR_DQM2	DIO	-	DRAM data mask 2	VDDQ	NC
DDR_DQM3	DIO	-	DRAM data mask 3	VDDQ	NC
DDR_DQSP0	DIO	-	DRAM data strobe 0	VDDQ	To DRAM
DDR_DQSN0	DIO	-	DRAM data strobe 0 complementary	VDDQ	To DRAM
DDR_DQSP1	DIO	-	DRAM data strobe 1	VDDQ	To DRAM
DDR_DQSN1	DIO	-	DRAM data strobe 1 complementary	VDDQ	To DRAM
DDR_DQSP2	DIO	-	DRAM data strobe 2	VDDQ	NC
DDR_DQSN2	DIO	-	DRAM data strobe 2 complementary	VDDQ	NC
DDR_DQSP3	DIO	-	DRAM data strobe 3	VDDQ	NC
DDR_DQSN3	DIO	-	DRAM data strobe 3 complementary	VDDQ	NC
PZQ	A	-	DRAM reference pin for ZQ calibration, to GND by 240ohm	VDDQ	To GND by 240ohm
PVREF			DRAM reference voltage	VDDQ	To GND by capacitor
AVDD_DDRPLL	P		Analog power supply for DDRPLL	-	To DDR VDDQ
<b>USB</b>					
USBHOST_A_DP	AIO	-	USB 2.0 Port A positive data signal (Host only)	AVDD33_USB	NC
USBHOST_A_DM	AIO	-	USB 2.0 Port A negative data signal (Host only)	AVDD33_USB	NC
USBOTG_B_DP	AIO	-	USB 2.0 Port B positive data signal (OTG)	AVDD33_USB	NC
USBOTG_B_DM	AIO	-	USB 2.0 Port B negative data signal (OTG)	AVDD33_USB	NC
USBOTG_B_ID	AIO	-	USB OTG mini-receptacle identifier (Internal 12.8KΩ pull-up resistor to AVDD18)	AVDD18_USB	NC
USBOTG_B_VBUS	AIO	-	USB OTG cable power detection	AVDD18_USB	NC

Net Name	Type	Default Pull UP/DN	Description	Power Domain	If Unused
USB_TXRTUNE	AIO	-	USB 2.0 Port A B host output strength setting resistor	AVDD18_USB	NC
AVDD33_USB	P	-	3.3V Power supply for USB	-	To 3.3V
AVDD18_USB	P	-	1.8V Power supply for USB	-	To 1.8V
<b>Ethernet</b>					
ENET_ATP	AIO	-	Ethernet PHY analog test pin	AVDD18_NET	NC
ENET_EXTRES	A	-	Ethernet PHY external resistor connection	AVDD18_NET	NC
ENET_RXN	AIO	-	Ethernet PHY receive data negative input	AVDD18_NET	NC
ENET_RXP	AIO	-	Ethernet PHY receive data positive input	AVDD18_NET	NC
ENET_TXN	AIO	-	Ethernet PHY transmit data negative output	AVDD18_NET	NC
ENET_TXP	AIO	-	Ethernet PHY transmit data positive output	AVDD18_NET	NC
AVDD18_ENET	AP	-	Analog 1.8V power supply for Ethernet module	-	To 1.8V
<b>Audio DAC</b>					
LOLN	AO	-	Audio DAC line-out left channel negative signal	AVDD18_Audio	NC
LOLP	AO	-	Audio DAC line-out left channel positive signal	AVDD18_Audio	NC
LORN	AO	-	Audio DAC line-out right channel negative signal	AVDD18_Audio	NC
LORP	AO	-	Audio DAC line-out right channel positive signal	AVDD18_Audio	NC
REFP	A	-	Audio DAC positive reference voltage	AVDD18_Audio	NC
VMID	A	-	Audio DAC external filter cap connection	AVDD18_Audio	NC
AVDD18_AUDIO	AP	-	Analog 1.8V for Audio DAC	-	To 1.8V
AVSS_Audio	AP	-	Analog power ground for Audio DAC	-	To VSS
<b>PCIE</b>					
PCIE_CLK_n	AO	-	PCIE reference clock negative signal	AVDD18_PCIE	NC
PCIE_CLK_p	AO	-	PCIE reference clock positive signal	AVDD18_PCIE	NC
PCIE_REXT	AIO	-	PCIE output strength setting resistor	AVDD18_PCIE	NC
PCIE_RXN	AI	-	PCIE or USB3.0 input negative signal	AVDD18_PCIE	NC

Net Name	Type	Default Pull UP/DN	Description	Power Domain	If Unused
PCIE_RXP	AI	-	PCIE or USB3.0 input positive signal	AVDD18_PPCIE	NC
PCIE_TXN	AO	-	PCIE or USB3.0 output negative signal	AVDD18_PPCIE	NC
PCIE_TXP	AO	-	PCIE or USB3.0 output positive signal	AVDD18_PPCIE	NC
AVDD0V8_USB_PCIE	AP	-	Analog 0.8V power supply for USB and PCIE	-	To VDD_EE
AVDD18_PPCIE	AP	-	Analog 1.8V power supply for PCIE	-	To 1.8V
HCSL_REXT	AIO	-	PCIE reference clk output strength setting resistor	AVDD18_PPCIE	NC
<b>System Clock &amp; PLL</b>					
SYS_OSCIN	AI	-	24MHz crystal oscillator input	VDD18_AO_XTAL	To XTAL
SYS_OSCOUT	AO	-	24MHz crystal oscillator output	VDD18_AO_XTAL	To XTAL
<b>Analog Power</b>					
AVSS_CVBS	AP	-	Ground of CVBS digital-analog converter	-	To GND
<b>Digital Power</b>					
VDDCPU	P	-	Power supply for CPU (Cortex A55)	-	To VDDCPU
VDDQ	P	-	DDR IO Power supply for DDR PHY	-	To VDDQ
VDD_EE	P	-	Power supply for GPU and core logic	-	To VDD_EE
AVDD18_AO	P	-	1.8V Power supply for Always On Domain	-	To 1.8V
<b>Digital Ground</b>					
DVSS	P	-	Digital power ground	-	To GND

**Abbreviations:**

- DI = Digital input pin
- DO = Digital output pin
- DIO = Digital input/output pin
- OD 5V = 5V input tolerant open drain (OD) output pin, need external pull up
- A = Analog setting or filtering pin
- AI = Analog input pin
- AO = Analog output pin
- AIO = Analog input/output pin
- P = Power pin
- AP = Analog power pin

- NC = No connection
- UP = Pull-Up
- DOWN = Pull-down
- Z = High-Z

## 4.4 Pin Multiplexing Tables

Multiple usage pins are used to conserve pin consumption for different features. The processor devices can be used in many different applications but each application will not utilize all the on chip features. As a result, some of the features share the same pin. Most of the multiple usage pins can be used as a GPIO pin as well.

**Table 4-1 GPIOZ\_x Multi-Function Pin**

Pin Name	Func1	Func2	Func3	Func4	Func5	Func6	Func7
GPIOZ_0	ETH_MDIO		ISO7816_CLK	I2C_EE_M0_SDA	PWM_B	I2C_EE_M1_SDA	
GPIOZ_1	ETH_MDC		ISO7816_DATA	I2C_EE_M0_SCL	PWM_C	I2C_EE_M1_SCL	
GPIOZ_2	ETH_RGMII_RX_CLK	PWM_D	TSIN_B_VALID	TDMC_D0	SDCARD_D0	TDMC_DIN0	PDM_DIN0
GPIOZ_3	ETH_RX_DV		TSIN_B_SOP	TDMC_D1	SDCARD_D1	TDMC_DIN1	PDM_DIN1
GPIOZ_4	ETH_RXD0		TSIN_B_DIN0	TDMC_D2	SDCARD_D2	TDMC_DIN2	PDM_DIN2
GPIOZ_5	ETH_RXD1		TSIN_B_CLK	TDMC_D3	SDCARD_D3	TDMC_DIN3	PDM_DIN3
GPIOZ_6	ETH_RXD2_RGMII		TSIN_B_FAIL	TDMC_FS	SDCARD_CLK	TDMC_SLV_FS	PDM_DCLK
GPIOZ_7	ETH_RXD3_RGMII		TSIN_B_DIN1	TDMC_SCLK	SDCARD_CMD	TDMC_SLV_SCLK	I2C_EE_M0_SDA
GPIOZ_8	ETH_RGMII_TX_CLK		TSIN_B_DIN2	MCLK_1			I2C_EE_M0_SCL
GPIOZ_9	ETH_TXEN		TSIN_B_DIN3	TDMC_D4			
GPIOZ_10	ETH_TXD0		TSIN_B_DIN4	I2C_EE_M2_SDA	IR_REMOTE_OUT		
GPIOZ_11	ETH_TXD1		TSIN_B_DIN5	I2C_EE_M2_SCL			
GPIOZ_12	ETH_TXD2_RGMII		TSIN_B_DIN6	TDMC_D5	PWM_F		
GPIOZ_13	ETH_TXD3_RGMII	CLK12_24	TSIN_B_DIN7		PWM_B		GEN_CLK_EE

Pin Name	Func1	Func2	Func3	Func4	Func5	Func6	Func7
GPIOZ_14	ETH_LINK_LED		I2C_EE_M2_SDA				
GPIOZ_15	ETH_ACT_LED		I2C_EE_M2_SCL				

Table 4-2 GPIOA\_x Multi-Function Pin

Pin Name	Func1	Func2
GPIOA_14	WORLD_SYNC	I2C_EE_M3_SDA
GPIOA_15	IR_REMOTE_INPUT	I2C_EE_M3_SCL

Table 4-3 BOOT\_x Multi-Function Pin

Pin Name	Func1	Func2	Func3
BOOT_0	EMMC_D0		
BOOT_1	EMMC_D1		
BOOT_2	EMMC_D2		
BOOT_3	EMMC_D3		NOR_HOLD
BOOT_4	EMMC_D4		NOR_D
BOOT_5	EMMC_D5		NOR_Q
BOOT_6	EMMC_D6		NOR_C
BOOT_7	EMMC_D7		NOR_WP
BOOT_8	EMMC_CLK	NAND_WEN_CLK	
BOOT_9		NAND_ALE	
BOOT_10	EMMC_CMD	NAND_CLE	
BOOT_11		NAND_CE0	
BOOT_12		NAND_REN_WR	
BOOT_13	EMMC_NAND_DQS		
BOOT_14		NAND_RB0	NOR_CS
BOOT_15		NAND_CE1	

Table 4-4 GPIOC\_x Multi-Function Pin

Pin Name	Func1	Func2	Func3	Func4	Func5
GPIOC_0	SDCARD_D0	JTAG_B_TDO		PDM_DIN0	SPI_A_MOSI
GPIOC_1	SDCARD_D1	JTAG_B_TDI		PDM_DIN1	SPI_A_MISO
GPIOC_2	SDCARD_D2	UART_AO_A_RX		PDM_DIN2	SPI_A_SS0
GPIOC_3	SDCARD_D3	UART_AO_A_TX		PDM_DIN3	SPI_A_SCLK



Pin Name	Func1	Func2	Func3	Func4	Func5
GPIOC_4	SDCARD_CLK	JTAG_B_CLK		PDM_DCLK	PWM_C
GPIOC_5	SDCARD_CMD	JTAG_B_TMS	I2C_EE_M0_SDA		ISO7816_CLK
GPIOC_6			I2C_EE_M0_SCL		ISO7816_DATA
GPIOC_7	PCIECK_REQN	WORLD_SYNC			

Table 4-5 GPIOX\_x Multi-Function Pin

Pin Name	Func1	Func2	Func3	Func4	Func5	Func6	Func7
GPIOX_0	SDIO_D0	PDM_DIN0	TSIN_A_DIN0		SDCARD_D0		
GPIOX_1	SDIO_D1	PDM_DIN1	TSIN_A_SOP		SDCARD_D1		
GPIOX_2	SDIO_D2	PDM_DIN2	TSIN_A_VALID		SDCARD_D2		
GPIOX_3	SDIO_D3	PDM_DIN3	TSIN_A_CLK	PWM_D	SDCARD_D3		
GPIOX_4	SDIO_CLK	PDM_DCLK			SDCARD_CLK		
GPIOX_5	SDIO_CMD	MCLK_1		PWM_C	SDCARD_CMD		
GPIOX_6	PWM_A	UART_EE_B_TX		PWM_D			
GPIOX_7	PWM_F	UART_EE_B_RX		PWM_B			
GPIOX_8	TDMA_D1	TDMA_DIN1	TSIN_B_SOP	SPI_A_MOSI	PWM_C	ISO7816_CLK	
GPIOX_9	TDMA_D0	TDMA_DIN0	TSIN_B_VALID	SPI_A_MISO		ISO7816_DATA	
GPIOX_10	TDMA_FS	TDMA_SLV_FS	TSIN_B_DIN0	SPI_A_SS0	I2C_EE_M1_SDA		
GPIOX_11	TDMA_SCLK	TDMA_SLV_SCLK	TSIN_B_CLK	SPI_A_SCLK	I2C_EE_M1_SCL		
GPIOX_12	UART_EE_A_TX						
GPIOX_13	UART_EE_A_RX						
GPIOX_14	UART_EE_A_CTS						
GPIOX_15	UART_EE_A_RTS						
GPIOX_16	PWM_E						
GPIOX_17	I2C_EE_M2_SDA						

Pin Name	Func1	Func2	Func3	Func4	Func5	Func6	Func7
GPIOX_18	I2C_EE_M2_SCL						
GPIOX_19	PWM_B	WORLD_SYNC					GEN_CLK_EE

Table 4-6 GPIOH\_x Multi-Function Pin

Pin Name	Func1	Func2	Func3	Func4	Func5	Func6
GPIOH_0	HDMITX_SDA	I2C_EE_M3_SDA				
GPIOH_1	HDMITX_SCL	I2C_EE_M3_SCL				
GPIOH_2	HDMITX_HPD_IN	I2C_EE_M1_SDA				
GPIOH_3		I2C_EE_M1_SCL		AO_CEC_A	AO_CEC_B	
GPIOH_4	SPDIF_OUT	UART_EE_C_RTS	SPI_B_MOSI			
GPIOH_5	SPDIF_IN	UART_EE_C_CTS	SPI_B_MISO	PWM_F	TDMB_D3	TDMB_DIN3
GPIOH_6	ISO7816_CLK	UART_EE_C_RX	SPI_B_SS0	I2C_EE_M1_SDA	IR_REMOTE_OUT	
GPIOH_7	ISO7816_DATA	UART_EE_C_TX	SPI_B_SCLK	I2C_EE_M1_SCL	PWM_B	
GPIOH_8						

Table 4-7 GPIOAO\_x Multi-Function Pin

Pin Name	Func1	Func2	Func3	Func4	Func5	Func6	Func7
GPIOAO_0	UART_AO_A_TX						
GPIOAO_1	UART_AO_A_RX						
GPIOAO_2	I2C_AO_M0_SCL	UART_AO_B_TX	I2C_AO_S0_SCL				
GPIOAO_3	I2C_AO_M0_SDA	UART_AO_B_RX	I2C_AO_S0_SDA				
GPIOAO_4	IR_REMOTE_OUT	CLK_32K_IN	PWMAO_C	PWMAO_C_HIZ	TDMB_D0	TDMB_DIN0	
GPIOAO_5	IR_REMOTE_INPUT		PWMAO_D				
GPIOAO_6	JTAG_A_CLK		PWMAO_C	TSIN_A_SOP	TDMB_D2	TDMB_DIN2	
GPIOAO_7	JTAG_A_TMS			TSIN_A_DIN0	TDMB_FS	TDMB_SLV_FS	

Pin Name	Func1	Func2	Func3	Func4	Func5	Func6	Func7
GPIOAO_8	JTAG_A_TDI		UART_AO_B_TX	TSIN_A_CLK	TDMB_SCLK	TDMB_SLV_SCLK	
GPIOAO_9	JTAG_A_TDO	IR_REMOTE_OUT	UART_AO_B_RX	TSIN_A_VALID	MCLK_0		
GPIOAO_10	AO_CEC_A	AO_CEC_B	PWMAO_D	SPDIF_OUT	TDMB_D1	TDMB_DIN1	CLK12_24
GPIOAO_11		PWMAO_A_HIZ	PWMAO_A	GEN_CLK_EE	GEN_CLK_AO		

Table 4-8 GPIOE\_x Multi-Function Pin

Pin Name	Func1	Func2	Func3	Func4
GPIOE_0	UART_AO_A_CTS	UART_AO_B_CTS	PWMAO_B	I2C_AO_M0_SCL
GPIOE_1	UART_AO_A_RTS	UART_AO_B_RTS	PWMAO_D	I2C_AO_M0_SDA
GPIOE_2	CLK12_24	CLK25_EE	PWM_A	

Table 4-9 DDR AC Multi-Function Pin

Pin Name	LPDDR3	LPDDR4	DDR3	DDR4
AC_0	CKEA0	CKEA0	CKE0	CKE0
AC_1	CKEA1	CKEA1	CKE1	CKE1
AC_2	CSA0	CSA0	CS_N0	CS_N0
AC_3	CSA1	CSA1	NC	NC
AC_4	CLKA_T	CLKA_T	CAS_N	A6
AC_5	CLKA_C	CLKA_C	BA2	A8
AC_6	NC	NC	A7	A2
AC_7	NC	NC	A5	A11
AC_8	CAA2	CAA2	A10	A10
AC_9	CAA7	CAA3	WE_N	BG1
AC_10	CAA1	CAA1	A0	A3
AC_11	CAA4	CAA0	A2	A12
AC_12	CAA5	CAA5	A9	A0
AC_13	CAA6	CAA4	A13	A4
AC_14	CAA0	NC	A14	A13
AC_15	CAA3	NC	A11	A9
AC_16	CAA9	NC	CLK0_T	CLK0_T
AC_17	CAA8	NC	CLK0_C	CLK0_C
AC_18	ODTA	NC	NC	NC
AC_20	NC	CKEB0	CLK1_T	CLK1_T

Pin Name	LPDDR3	LPDDR4	DDR3	DDR4
AC_21	NC	CKEB1	CLK1_C	CLK1_C
AC_22	NC	CSB1	NC	NC
AC_23	NC	CSB0	NC	NC
AC_24	NC	CLKB_T	A6	A5
AC_25	NC	CLKB_C	A4	BA1
AC_26	NC	NC	A1	A1
AC_28	NC	CAB1	A8	A7
AC_29	NC	CAB3	BA1	RAS_N/A16
AC_30	NC	CAB5	A15	ACT_N
AC_31	NC	CAB2	RAS_N	WE_N/A14
AC_32	NC	CAB4	NC	NC
AC_33	NC	CAB0	A12	CAS_N/A15
AC_34	NC	NC	A3	BA0
AC_35	NC	NC	BA0	BG0
AC_36	NC	NC	ODT0	ODT0
AC_37	NC	NC	ODT1	ODT1
AC_38	NC	NC	CS_N1	CS_N1
DDR_RSTn	NC	RESET_N	RESET_N	RESET_N
PVREF	PVREF	PVREF	PVREF	PVREF
PZQ	PZQ	PZQ	PZQ	PZQ

Table 4-10 PCIE IO Multi-Function Pin

Pin Name	Func1	Func2
PCIE_RXN	PCIE_RXN	USB3.0_RXN
PCIE_RXP	PCIE_RXP	USB3.0_RXP
PCIE_TXN	PCIE_TXN	USB3.0_TXN
PCIE_TXP	PCIE_TXP	USB3.0_TXP

## 4.5 Signal Description

Table 4-11 SD Card Interface Signal Description

Signal Name	Type	Description
SDCARD_D0	DIO	SD Card data bus bit 0 signal
SDCARD_D1	DIO	SD Card data bus bit 1 signal
SDCARD_D2	DIO	SD Card data bus bit 2 signal

Signal Name	Type	Description
SDCARD_D3	DIO	SD Card data bus bit 3 signal
SDCARD_CLK	DO	SD Card clock signal
SDCARD_CMD	DIO	SD Card command signal

Table 4-12 SDIO Interface Signal Description

Signal Name	Type	Description
SDIO_D0	DIO	SDIO data bus bit 0 signal
SDIO_D1	DIO	SDIO data bus bit 1 signal
SDIO_D2	DIO	SDIO data bus bit 2 signal
SDIO_D3	DIO	SDIO data bus bit 3 signal
SDIO_CLK	DO	SDIO clock signal
SDIO_CMD	DIO	SDIO command signal

Table 4-13 Clock Interface Signal Description

Signal Name	Type	Description
CLK_32K_IN	DI	32KHz clock input
CLK12_24	DO	12MHz/24MHZ clock output
CLK25_EE	DO	25MHz clock output

Table 4-14 UART Interface Signal Description

Signal Name	Type	Description
UART_AO_A_TX	DO	UART Port A data output in AO domain
UART_AO_A_RX	DI	UART Port A data input in AO domain
UART_AO_A_CTS	DI	UART Port A Clear To Send Signal in AO domain
UART_AO_A_RTS	DO	UART Port A Ready To Send Signal in AO domain
UART_AO_B_TX	DO	UART Port B data output in AO domain
UART_AO_B_RX	DI	UART Port B data input in AO domain
UART_AO_B_CTS	DI	UART Port B Clear To Send Signal in AO domain
UART_AO_B_RTS	DO	UART Port B Ready To Send Signal in AO domain
UART_EE_A_TX	DO	UART Port A data output in EE domain
UART_EE_A_RX	DI	UART Port A data input in EE domain
UART_EE_A_CTS	DI	UART Port A Clear To Send Signal in EE domain
UART_EE_A_RTS	DO	UART Port A Ready To Send Signal in EE domain
UART_EE_B_TX	DO	UART Port B data output in EE domain
UART_EE_B_RX	DI	UART Port B data input in EE domain
UART_EE_C_TX	DO	UART Port C data output in EE domain
UART_EE_C_RX	DI	UART Port C data input in EE domain

Signal Name	Type	Description
UART_EE_C_CTS	DI	UART Port C Clear To Send Signal in EE domain
UART_EE_C_RTS	DO	UART Port C Ready To Send Signal in EE domain

**Table 4-15 ISO7816 Interface Signal Description**

Signal Name	Type	Description
ISO7816_DATA	DIO	ISO7816 data signal
ISO7816_CLK	DO	ISO7816 clock signal

**Table 4-16 TS In Interface Signal Description**

Signal Name	Type	Description
TSIN_A_DIN0	DI	Serial TS input port A data
TSIN_A_CLK	DI	TS input port A clock
TSIN_A_SOP	DI	TS input port A start of stream signal
TSIN_A_VALID	DI	TS input port A date valid signal
TSIN_B_DIN0	DI	Serial/Parallel TS input port B data 0
TSIN_B_DIN1	DI	Parallel TS input port B data 1
TSIN_B_DIN2	DI	Parallel TS input port B data 2
TSIN_B_DIN3	DI	Parallel TS input port B data 3
TSIN_B_DIN4	DI	Parallel TS input port B data 4
TSIN_B_DIN5	DI	Parallel TS input port B data 5
TSIN_B_DIN6	DI	Parallel TS input port B data 6
TSIN_B_DIN7	DI	Parallel TS input port B data 7
TSIN_B_FAIL	DI	TS input port B fail signal
TSIN_B_CLK	DI	TS input port B clock
TSIN_B_SOP	DI	TS input port B start of stream signal
TSIN_B_VALID	DI	TS input port B date valid signal

**Table 4-17 PWM Interface Signal Description**

Signal Name	Type	Description
PWM_A	DO	PWM channel A output signal
PWM_B	DO	PWM channel B output signal
PWM_C	DO	PWM channel C output signal
PWM_D	DO	PWM channel D output signal
PWM_E	DO	PWM channel E output signal
PWM_F	DO	PWM channel F output signal
PWMAO_A / PWMAO_A_HIZ	DO	PWM A output signal in Always On domain, or extended HiZ function of PWMAO_A

Signal Name	Type	Description
PWMAO_B	DO	PWM B output signal in Always On domain
PWMAO_C / PWMAO_C_HIZ	DO	PWM C output signal in Always On domain, or extended HiZ function of PWMAO_C
PWMAO_D	DO	PWM D output signal in Always On domain

**Table 4-18 I2C Interface Signal Description**

Signal Name	Type	Description
I2C_AO_M0_SCL	DO	I2C bus port 0 clock output, Master mode, in AO domain
I2C_AO_M0_SDA	DIO	I2C bus port 0 data input/output, Master mode, in AO domain
I2C_AO_S0_SCL	DI	I2C bus port 0 clock input, Slave mode, in AO domain
I2C_AO_S0_SDA	DIO	I2C bus port 0 data input/output, Slave mode, in AO domain
I2C_EE_M0_SCL	DO	I2C bus port 0 clock output, Master mode, in EE domain
I2C_EE_M0_SDA	DIO	I2C bus port 0 data input/output, Master mode, in EE domain
I2C_EE_M1_SCL	DO	I2C bus port 1 clock output, Master mode, in EE domain
I2C_EE_M1_SDA	DIO	I2C bus port 1 data input/output, Master mode, in EE domain
I2C_EE_M2_SCL	DO	I2C bus port 2 clock output, Master mode, in EE domain
I2C_EE_M2_SDA	DIO	I2C bus port 2 data input/output, Master mode, in EE domain
I2C_EE_M3_SCL	DO	I2C bus port 3 clock output, Master mode, in EE domain
I2C_EE_M3_SDA	DIO	I2C bus port 3 data input/output, Master mode, in EE domain

**Table 4-19 eMMC Interface Signal Description**

Signal Name	Type	Description
EMMC_D0	DIO	eMMC/NAND data bus bit 0 signal
EMMC_D1	DIO	eMMC/NAND data bus bit 1 signal
EMMC_D2	DIO	eMMC/NAND data bus bit 2 signal
EMMC_D3	DIO	eMMC/NAND data bus bit 3 signal
EMMC_D4	DIO	eMMC/NAND data bus bit 4 signal
EMMC_D5	DIO	eMMC/NAND data bus bit 5 signal
EMMC_D6	DIO	eMMC/NAND data bus bit 6 signal
EMMC_D7	DIO	eMMC/NAND data bus bit 7 signal
EMMC_CLK	DO	eMMC clock signal
EMMC_CMD	DIO	eMMC command signal
EMMC_NAND_DQS	DIO	eMMC/NAND data strobe

**Table 4-20 NAND Signal Description**

Signal Name	Type	Description
NAND_RB0	DI	NAND ready/busy
NAND_ALE	DO	NAND address latch enable
NAND_CE0	DO	NAND chip enable 0
NAND_CE1	DO	NAND chip enable 1
NAND_CLE	DO	NAND command latch enable
NAND_REN_WR	DO	NAND read enable or write/read
NAND_WEN_CLK	DO	NAND write enable or clock

**Table 4-21 NOR Interface Signal Description**

Signal Name	Type	Description
NOR_CS	DO	SPI NOR chip select
NOR_C	DO	SPI NOR Serial Clock
NOR_D	DIO	SPI NOR 1bit mode Output, 2/4 bit mode data I/O 0
NOR_Q	DIO	SPI NOR 1bit mode Input, 2/4 bit mode data I/O 1
NOR_WP	DIO	SPI NOR Write protection output, 4 bit mode data I/O 2
NOR_HOLD	DIO	SPI bus hold output, 4 bit mode data I/O 3

**Table 4-22 HDMI Interface Signal Description**

Signal Name	Type	Description
HDMITX_SDA	DIO	HDMI TX DDC_I2C interface data signal
HDMITX_SCL	DO	HDMI TX DDC_I2C interface clock signal
HDMITX_HPD_IN	DI	HDMI TX hot-plug in signal input
AO_CEC_A	DIO	Customer Electronics Control signal in AO domain
AO_CEC_B	DIO	2nd pin of Customer Electronics Control signal in AO domain

**Table 4-23 SPDIF Interface Signal Description**

Signal Name	Type	Description
SPDIF_IN	DI	SPDIF input signal
SPDIF_OUT	DO	SPDIF output signal

**Table 4-24 PCIE Interface Signal Description**

Signal Name	Type	Description
PCIECK_REQN	DI	PCIE clock request input



**Table 4-25 SPI Interface Signal Description**

Signal Name	Type	Description
SPI_A_MOSI	DIO	SPI master output, slave input A
SPI_A_MISO	DIO	SPI master input, slave output A
SPI_A_SCLK	DIO	SPI clock A
SPI_A_SS0	DIO	SPI slave select 0 A
SPI_B_MOSI	DIO	SPI master output, slave input B
SPI_B_MISO	DIO	SPI master input, slave output B
SPI_B_SCLK	DIO	SPI clock B
SPI_B_SS0	DIO	SPI slave select 0 B

**Table 4-26 Remote Interface Signal Description**

Signal Name	Type	Description
IR_REMOTE_IN	DI	IR remote control input
IR_REMOTE_OUT	DO	IR remote control output

**Table 4-27 Time Division Multiplexing Signal Description**

Signal Name	Type	Description
MCLK_0	DO	Master clock output 0, for I2S master mode
MCLK_1	DO	Master clock output 1, for I2S master mode
TDMA_DIN0	DI	Data input 0 of TDM port A
TDMA_DIN1	DI	Data input 1 of TDM port A
TDMA_D0	DIO	Data input/output 0 of TDM port A
TDMA_D1	DIO	Data input/output 1 of TDM port A
TDMA_SCLK	DO	Bit clock output of TDM port A
TDMA_FS	DO	Frame sync output of TDM port A (Word clock of I2S)
TDMA_SLV_SCLK	DI	Bit clock input of TDM port A
TDMA_SLV_FS	DI	Frame sync input of TDM port A (Word clock of I2S)
TDMB_DIN0	DI	Data input 0 of TDM port B
TDMB_DIN1	DI	Data input 1 of TDM port B
TDMB_DIN2	DI	Data input 2 of TDM port B
TDMB_DIN3	DI	Data input 3 of TDM port B
TDMB_D0	DIO	Data input/output 0 of TDM port B
TDMB_D1	DIO	Data input/output 1 of TDM port B
TDMB_D2	DIO	Data input/output 2 of TDM port B
TDMB_D3	DIO	Data input/output 3 of TDM port B
TDMB_SCLK	DO	Bit clock output of TDM port B

Signal Name	Type	Description
TDMB_FS	DO	Frame sync output of TDM port B (Word clock of I2S)
TDMB_SLV_SCLK	DI	Bit clock input of TDM port B
TDMB_SLV_FS	DI	Frame sync input of TDM port B (Word clock of I2S)
TDMC_DIN0	DI	Data input 0 of TDM port C
TDMC_DIN1	DI	Data input 1 of TDM port C
TDMC_DIN2	DI	Data input 2 of TDM port C
TDMC_DIN3	DI	Data input 3 of TDM port C
TDMC_D0	DIO	Data input/output 0 of TDM port C
TDMC_D1	DIO	Data input/output 1 of TDM port C
TDMC_D2	DIO	Data input/output 2 of TDM port C
TDMC_D3	DIO	Data input/output 3 of TDM port C
TDMC_D4	DIO	Data input/output 4 of TDM port C
TDMC_D5	DIO	Data input/output 5 of TDM port C
TDMC_SCLK	DO	Bit clock output of TDM port C
TDMC_FS	DO	Frame sync output of TDM port C (Word clock of I2S)
TDMC_SLV_SCLK	DI	Bit clock input of TDM port C
TDMC_SLV_FS	DI	Frame sync input of TDM port C (Word clock of I2S)

Table 4-28 PDM Signal Description

Signal Name	Type	Description
PDM_DIN0	DI	PDM input data 0 signal
PDM_DIN1	DI	PDM input data 1 signal
PDM_DIN2	DI	PDM input data 2 signal
PDM_DIN3	DI	PDM input data 3 signal
PDM_DCLK	DO	PDM output clock signal

Table 4-29 JTAG Interface Signal Description

Signal Name	Type	Description
JTAG_A_TDO	DO	JTAG data output channel A
JTAG_A_TDI	DI	JTAG data input channel A
JTAG_A_TMS	DI	JTAG Test mode select input channel A
JTAG_A_CLK	DI	JTAG Test clock input channel A
JTAG_B_TDO	DO	JTAG data output channel B
JTAG_B_TDI	DI	JTAG data input channel B
JTAG_B_TMS	DI	JTAG Test mode select input channel B
JTAG_B_CLK	DI	JTAG Test clock input channel B

**Table 4-30 Ethernet Interface Signal Description**

Signal Name	Type	Description
ETH_LINK_LED	DO	Ethernet link LED indicator
ETH_ACT_LED	DO	Ethernet active LED indicator
ETH_RGMII_RX_CLK	DI	Ethernet RGMII interface receive clock input
ETH_RGMII_TX_CLK	DO	Ethernet RGMII transmit clock
ETH_TX_EN	DO	Ethernet RMII/RGMII Interface transmit enable
ETH_TXD3_RGMII	DO	Ethernet RGMII interface transmit data 3
ETH_TXD2_RGMII	DO	Ethernet RGMII interface transmit data 2
ETH_TXD1	DO	Ethernet RMII/RGMII interface transmit data 1
ETH_TXD0	DO	Ethernet RMII/RGMII interface transmit data 0
ETH_RX_DV	DI	Ethernet RMII/RGMII interface receive data valid signal
ETH_RXD3_RGMII	DI	Ethernet RGMII interface receive data 3
ETH_RXD2_RGMII	DI	Ethernet RGMII interface receive data 2
ETH_RXD1	DI	Ethernet RMII/RGMII interface receive data 1
ETH_RXD0	DI	Ethernet RMII/RGMII interface receive data 0
ETH_MDIO	DIO	Ethernet SMI interface management data input/output
ETH_MDC	DO	Ethernet SMI interface management clock

**Table 4-31 Other Signal Description**

Signal Name	Type	Description
WORLD_SYNC	DI	World clock sync input, to sync clock of multi devices
GEN_CLK_EE	DO	General clock output for EE domain clock, for debug
GEN_CLK_AO	DO	General clock output for AO domain clock, for debug

## 5 Operating Conditions

### 5.1 Absolute Maximum Ratings

The table below gives the absolute maximum ratings. Exposure to stresses beyond those listed in this table may result in permanent device damage, unreliability or both.

Characteristic	Value	Unit
VDDCPU Supply Voltage	1.1	V
VDD_EE Supply Voltage	1.0	V
VDDQ Supply Voltage	1.7	V
AVDD_DDRPLL	1.98	V
1.8V Supply Voltage	1.98	V
3.3V Supply Voltage	3.63	V
Input voltage, $V_i$	-0.3 ~ VDDIO+0.3	V
Junction Temperature	125	°C

### 5.2 Recommended Operating Conditions

Symbol	Parameter	Min.	Typ.	Max	Unit
VDDCPU	Voltage for Cortex A55 CPU	0.68 <sup>1</sup>	-	1.03 <sup>2</sup>	V
VDD_EE and other 0.8V domain	Voltage for GPU & core logic	0.77	0.8	0.9	V
VDDQ	DDR3/DDR3L/DDR4/LPDDR/ LPDDR3/LPDDR4 IO Supply Voltage	1.05	-	1.6	V
AVDD18	1.8V AVDD for HDMI, USB, PCIE, CVBS, ETHERNET phy, and AUDIO	1.71	1.80	1.89	V
AVDD18_AO	1.8V VDD for XTAL, IOVREF, SAR- ADC, GPIOE, PLL	1.71	1.80	1.89	V
AVDD_DDRPLL	Analog power supply for DDRPLL	1.05	-	1.89	V
AVDD33	3.3V AVDD for USB	3.15	3.3	3.45	V
VDDIO	LV mode	1.71	1.80	1.89	V
	HV mode	3.0 <sup>3</sup>	3.3	3.45	V
$T_J$	Operating Junction Temperature	0	—	105 <sup>4</sup>	°C
$T_A$	Operating Ambient Temperature	0	—	70	°C

**Note**

1. Minimal VDDCPU voltage is for sleep mode while system runs at very low speed. Higher clock will need higher voltage. Considering the power supply may have 3% deviation, the minimal voltage in actual application should not be set to lower than min spec plus 0.02V.
2. Likewise, maximum VDDCPU voltage in actual application should be lower than the max spec value minus 0.02V. Voltage of VDDCPU will affect CPU speed. Use lower voltage when CPU runs on lower speed to save power. Recommend to use +/-1.5% or higher precision DCDC.
3. GPIO cannot work if VDDIO voltage is out of the spec of LV / HV mode. GPIO output at HV mode will be weaker & max operating speed will be lower if VDDIO are design to 3.0V. Do not design VDDIO to lower than 3.0V in HV mode, recommend to use +/-1.5% or higher precision DCDC to supply power for VDDIO, actual voltage supplies to VDDIO (HV mode) should not be lower than 2.9V.
4. For operating temperature, good heat sink may be needed to guarantee  $T_j < \text{max spec}$ .

## 5.3 Ripple Voltage Specifications

Please check below table for ripple voltage specifications.

Power	Max Ripple	Unit	Test State
VDDCPU	40	+/-mV	Run APK StabilityTest
VDD_EE and other 0.8V domain	40	+/-mV	Run APK Basemark ES 2.0 Taiji
DDR3 VDDQ and AVDD_DDRPLL	60	+/-mV	Kernel boot
DDR3L VDDQ and AVDD_DDRPLL	60	+/-mV	Kernel boot
LPDDR3 VDDQ and AVDD_DDRPLL	40	+/-mV	Kernel boot
DDR4 VDDQ and AVDD_DDRPLL	40	+/-mV	Kernel boot
LPDDR4 VDDQ and AVDD_DDRPLL	40	+/-mV	Kernel boot
AVDD18	30	+/-mV	Kernel boot
AVDD18_AO	30	+/-mV	Kernel boot
AVDD33	50	+/-mV	WIFI SCAN
VDDIO LV	60	+/-mV	Kernel boot
VDDIO HV	60	+/-mV	WIFI SCAN

**Note**

Ripple specification is only a reference spec, customer should run stress/performance/reliability test (high/low temperature test, damp and hot test, function test, etc...) on their product to confirm the system stability.

## 5.4 Thermal Resistance

Jedec 2P2S board 101.5mm\*114.5mm, natural convection, ambient temperature 25°C.

Symbol	Parameter	Value(°C/Watt)	Air Flow(m/s)
$\Theta_{ja}$	Package junction-to-ambiance thermal resistance in nature convection	16.90	0
$\Theta_{jb}$	Package junction-to-pcb thermal resistance in nature convection	7.99	0
$\Theta_{jc}$	Package junction-to-case thermal resistance in nature convection	7.29	0

### Note

- Due to the thinness of the SOC, DRAM or capacitors placed close to SOC may prevent heat-sink touching SOC top side. A special convex shape heatsink is recommended.
- These measurement were conducted on a JEDEC defined 2S2P system. For more information, check below JEDEC standards:
  - JESD51-2A: Integrated Circuits Thermal Test Method Environmental Conditions - Natural Convection (Still Air)
  - JESD51-8: Integrated Circuit Thermal Test Method Environmental Conditions -Junction-to-Board
  - JESD51-12: Guidelines for Reporting and Using Electronic Package Thermal Information
- m/s = meters per second

## 5.5 DC Electrical Characteristics

### 5.5.1 Normal GPIO Specifications (For DIO\_xmA)

Symbol	Parameter	Min.	Typ.	Max.	Unit
$V_{IH}(VDDIO=3.3V)^3$	High-level input voltage	IOVREF+0.37	-	VDDIO+0.3	V
$V_{IL}(VDDIO=3.3V)^3$	Low-level input voltage	-0.3	-	IOVREF-0.23	V
$V_{IH}(VDDIO=1.8V)^3$	High-level input voltage	IOVREF/2+0.3	-	VDDIO+0.3	V
$V_{IL}(VDDIO=1.8V)^3$	Low-level input voltage	-0.3	-	IOVREF/2-0.3	V
$R_{PU}$	Built-in pull up resistor	50K	60K	70K	ohm
$R_{PD}$	Built-in pull down resistor	50K <sup>5</sup>	60K	500K <sup>6</sup>	ohm
$I_{oL}/I_{oH}(DS=0)^{1,4}$	GPIO driving capability	0.5	-	-	mA
$I_{oL}/I_{oH}(DS=1)^1$	GPIO driving capability	2.5	-	-	mA

Symbol	Parameter	Min.	Typ.	Max.	Unit
IoL/IoH(DS=2) <sup>1</sup>	GPIO driving capability	3	-	-	mA
IoL/IoH(DS=3) <sup>1</sup>	GPIO driving capability	4 <sup>2</sup>	-	-	mA
VOH	Output high level with IoL/IoH loading	VDDIO-0.5	-	-	V
VOL	Output low level with IoL/IoH loading	-	-	0.4	V

**Note**

1. With Minimal IoL/IoH driving capability loading, IO is guaranteed to meet Vol < 0.4V or VOH > (VDDIO-0.5V) spec.
2. Maximal GPIO loading is 6mA for application such as driving LED, which does not care about Vol/Voh spec. Please set DS=3 for such application.
3. VDD18\_AO\_XTAL supplies power to IOVREF.
4. Do not use this setting, it's too weak for most applications.
5. Test condition: GPIO pin voltage close to 0V.
6. Test condition: GPIO pin voltage close to VDDIO(3.3V).

**5.5.2 Open Drain GPIO Specifications (For DIO\_OD)**

Symbol	Parameter	Min.	Typ.	Max.	Unit
V <sub>IH</sub> (OD5V)	High-level input voltage	1.5		5.5	V
V <sub>IL</sub> (OD5V)	Low-level input voltage	-0.3		0.8	V
R <sub>PU/PD</sub>	No built-in pull up/down resistor on OD IO	-	-	-	ohm
Io	OD IO driving low capability	4		6	mA
VOL	Output low level with min Io loading			0.4	V

**Note**

1. With Minimal IoL driving capability loading, IO is guaranteed to meet Vol<0.4V spec
2. Maximal GPIO loading is 6mA for application such as driving LED, which does not care about Vol spec
3. The V<sub>IL</sub> / V<sub>IH</sub> of OD PAD is irrelevant to VDDIO voltage.
4. "OD 5V" means that in applications such as I2C, use a resistor greater than 1Kohm to pull it up to 5V. Do not connect the pad directly to the 5V power supply.

### 5.5.3 DDR3/DDR3L/DDR4/LPDDR3/LPDDR4 SDRAM Specifications

**Table 5-1 Recommended Operating Conditions**

Symbol	Parameter	Min.	Typ.	Max.	Unit
VDDQ	IO supply voltage (DDR3)	1.425	1.50	1.57	V
VDDQ	IO supply voltage (DDR3L)	1.283	1.35	1.45	V
VDDQ	IO supply voltage (DDR4)	1.14	1.20	1.30	V
VDDQ	IO supply voltage (LPDDR3)	1.14	1.2	1.30	V
VDDQ	IO supply voltage (LPDDR4)	1.06	1.1	1.17	V
Vref	Input reference supply voltage	0.49*VDDQ	0.5*VDDQ	0.51*VDDQ	V

#### Note

The minimal VDDQ voltage in sleep mode is defined by memory.

**Table 5-2 DC specifications - DDR3/DDR3L Mode**

Symbol	Parameter	Min.	Typ.	Max.	Unit
VIH	DC input voltage high	Vref + 0.100		VDDQ	V
VIL	DC input voltage low	VSSQ		Vref-0.100	V
VOH	DC output logic high	0.8*VDDQ			V
VOL	DC output logic low			0.2*VDDQ	V
RTT	Input termination resistance to VDDQ/2	100 54 36	120 60 40	140 66 44	ohm

**Table 5-3 DC specifications – DDR4 Mode**

Symbol	Parameter	Min.	Typ.	Max.	Unit
VdIVW_total	Rx Mask voltage-p-p total			136	mv
VOH	DC output logic high	0.9*VDDQ			V
VOL	DC output logic low			0.1*VDDQ	V
RTT	Input termination resistance to VDDQ	200	240	280	ohm
		100	120	140	
		67	80	93	
		50	60	70	
		42	48	56	
		34	40	46	
		28	34	40	



**Table 5-4 DC Specifications – LPDDR3 Mode**

Symbol	Parameter	Min.	Typ.	Max.	Unit
VIH	DC input voltage high	Vref + 0.100		VDDQ	V
VIL	DC input voltage low	VSSQ		Vref-0.100	V
VOH	DC output logic high	0.9*VDDQ			V
VOL	DC output logic low			0.1*VDDQ	V
RTT	Input termination resistance to VDDQ	100 200	120 240	140 280	ohm

**Table 5-5 DC Specifications – LPDDR4 Mode**

Symbol	Parameter	Min.	Typ.	Max.	Unit
VOH	DC output logic high	0.9*VDDQ	-	-	V
VOL	DC output logic low	-	-	0.1*VDDQ	V
RTT	Input termination resistance to VDDQ	216	240	264	ohm
		108	120	132	
		72	80	88	
		54	60	66	
		43.2	48	52.8	
		36	40	44	

## 5.6 Recommended Oscillator Electrical Characteristics

The SoC requires the 24MHz oscillator for generating the main clock source.

Symbol	Description	Min.	Typ.	Max.	Unit	Notes
F <sub>o</sub>	Nominal Frequency		24		MHz	
Δf/f <sub>o</sub>	Frequency Tolerance	-30		30	ppm	At 25 °C
		-50		50	ppm	At -20~85 °C
C <sub>L</sub>	Load Capacitance	7.5	12	12.5	pF	
ESR	Equivalent Series Resistance			100	oHm	

**Note**

1. 10ppm Tolerance is preferred if 24MHz XTAL is also driving WIFI module.
2. For user external clock source, please connect input clock output to SYS\_OSCIN , let SYS\_OSCOUT floating.
3. The threshold of Xin inverter is around 0.9V (Xin range: -0.3V to +2.1V). Therefore, Following suggestion for input clock.
  - Suggestion 1: Without DC blocking capacitor, use a higher Vpp output TCXO. The high voltage should be higher than 1.35V (VSWING >1.35V, 0V to >1.35V).
  - Suggestion 2: With DC blocking capacitor, re-bias the middle voltage at 0.9V, VSWING >2\*0.45V;

## 5.7 Timing Information

### 5.7.1 I2C Timing Specification

The I2C master interface Fast/Standard mode timing specifications are shown below.

**Figure 5-1 I2C Interface Timing Diagram, FS mode**

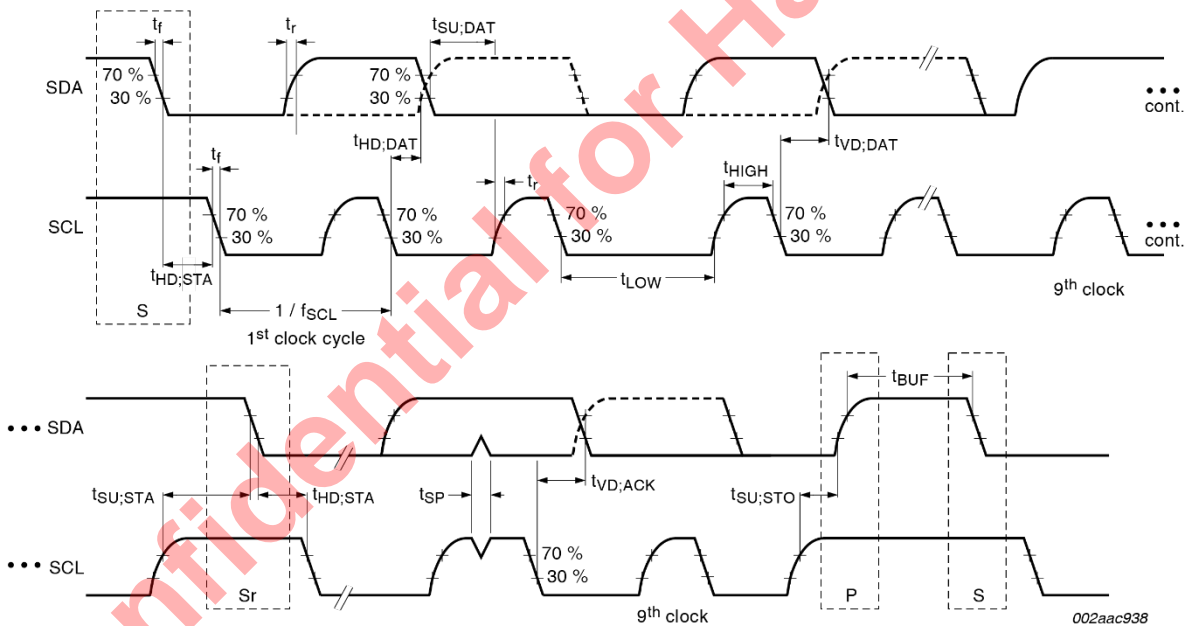

**Table 5-6 I2C Interface Timing Specification, SF mode**

Symbol	Parameter	Standard-mode		Fast-mode		Unit
		Min.	Max	Min	Max	
tR	Rise time of SDA and SCL signals	-	1000	-	300	ns
tF	Fall time of SDA and SCL signals	-	300	-	300	ns
fSCL	SCL clock frequency	-	100	-	400	KHz
tLOW	LOW period of the SCL clock	4.7	-	1.3	-	μs
tHIGH	HIGH period of the SCL clock	4	-	0.6	-	μs
tSu;STA	Setup time for START	4.7	-	0.6	-	μs
tSu;DAT	Setup time for SDA	250	-	100	-	ns
tSu;STO	Setup time for STOP	4	-	0.6	-	μs
tHd;STA	Hold time for START	4	-	0.6	-	μs
tHd;DAT	Hold time for SDA	0	3.45	0	0.9	μs
tBuf	Bus free time between stop and start	4.7	-	1.3	-	μs

**Note**

- Open drain does not support driver strength adjustment.

**5.7.2 EMMC/SD Timing Specification**

Timing specification for EMMC and SDIO are shown as below.

Figure 5-2 EMMC HS400 Data Output Timing

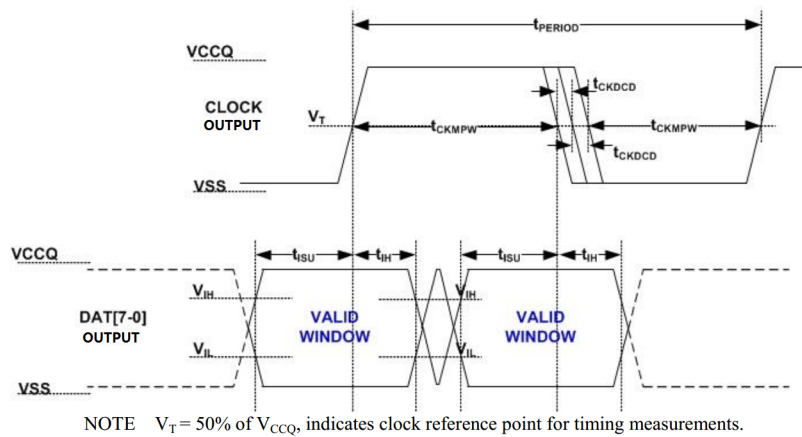

Table 5-7 HS400 Timing Specification

Symbol	Parameter	Min	Max	Unit
tPERIOD	Cycle time data transfer mode	5	-	ns
SR	Slew rate	1.125	-	V/ns
tCKDCD	Duty cycle distortion	0	0.3	ns
tCKMPW	Minimum pulse width	2.2	-	ns
tISU	input set-up time	1.4	-	ns
tIH	input hold time	0.8	-	ns
tISUddr	input set-up time	0.4	-	ns
tIHddr	input hold time	0.4	-	ns

Figure 5-3 EMMC HS200 Data Output Timing

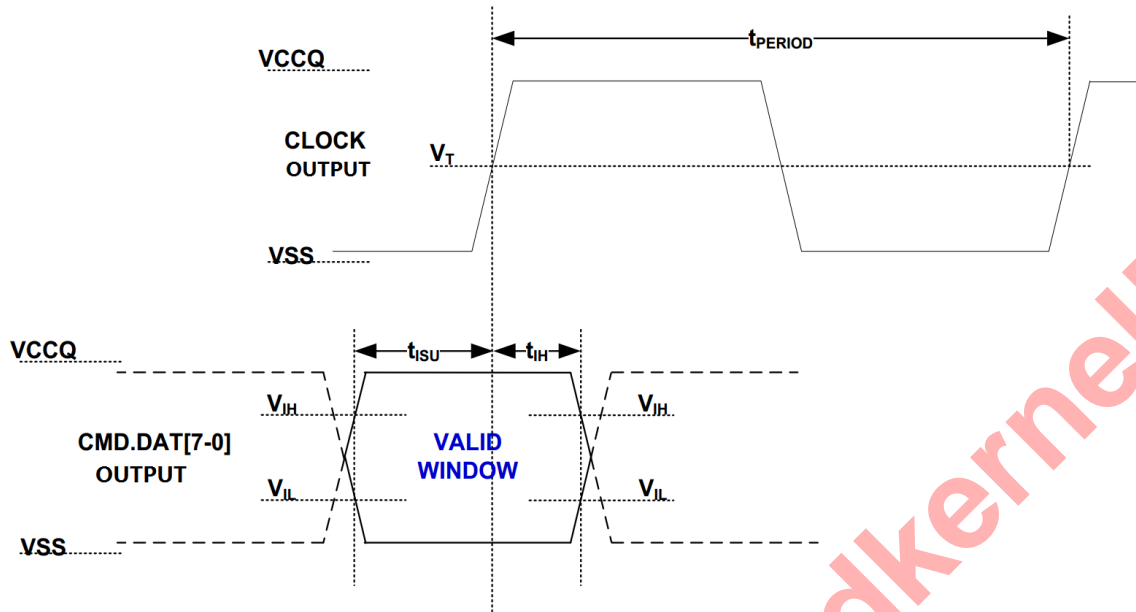
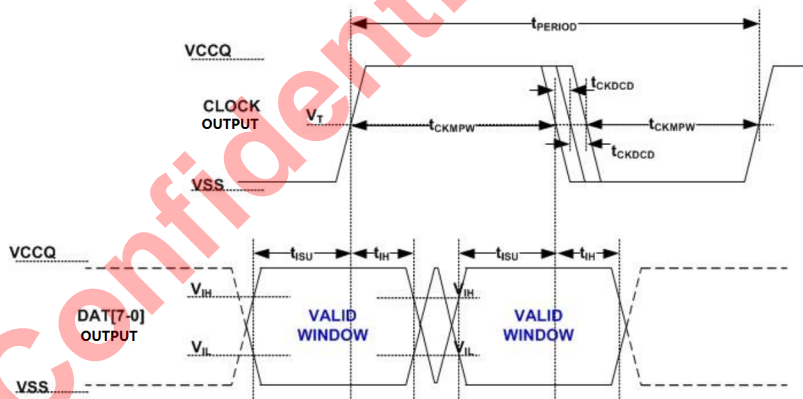

Table 5-8 HS200 Timing Specification

Symbol	Parameter	Min	Max	Unit
t <sub>PERIOD</sub>	Cycle time data transfer mode	5	-	ns
t <sub>ISU</sub>	output set-up time	1.4	-	ns
t <sub>IH</sub>	output hold time	0.8	-	ns

Figure 5-4 EMMC HS400 Data Input Timing



NOTE  $V_T = 50\%$  of  $V_{CCQ}$ , indicates clock reference point for timing measurements.

**Table 5-9 HS400 Data Input Timing Specification**

Symbol	Parameter	Min	Max	Unit
tPERIOD	Cycle time data transfer mode	5	-	ns
SR	Slew rate	1.125	-	V/ns
tCKDCD	Duty cycle distortion	0	0.2	ns
tCKMPW	Minimum pulse width	2	-	ns
tRQ	Input skew	-	0.4	ns
tRQH	input hold skew	-	0.4	ns

**Figure 5-5 EMMC HS200 Data Input Timing**

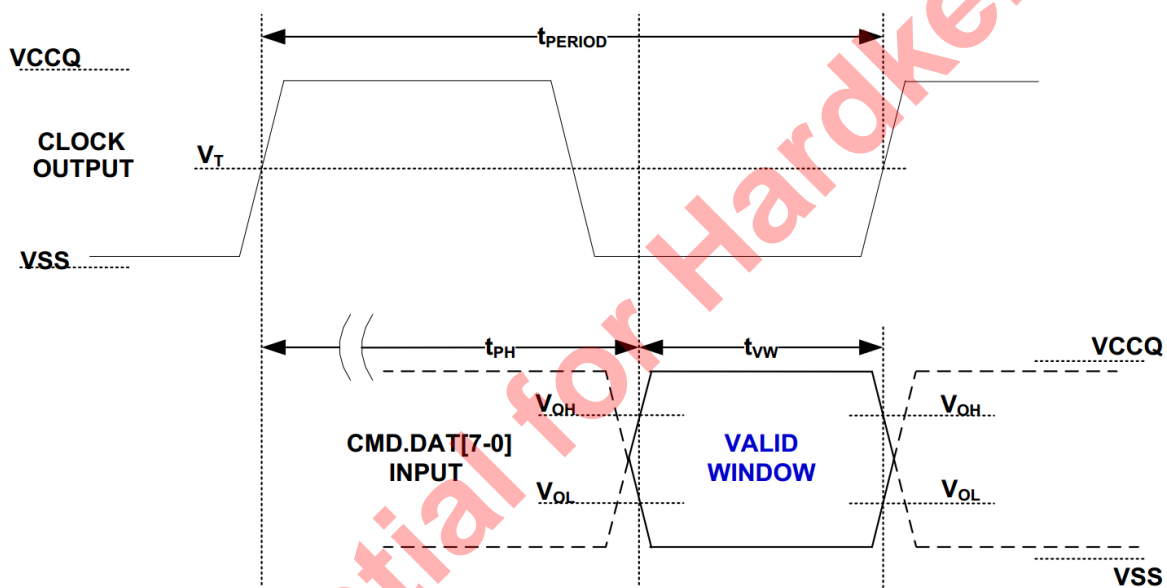

**Table 5-10 HS200 Timing Specification**

Symbol	Parameter	Min	Max	Unit
tPH	Device output momentary phase from CLK input to CMD or DAT line output. Does not include a longterm temperature drift.	0	2	UI
ΔTPH	Delay variation due to temperature change after tuning. Total allowable shift of output valid window (TVW) from last system Tuning procedure ΔTPH is 2600ps for ΔT from -25 °C to 125 °C during operation.	-350(ΔT=-20deg.C)	1550(ΔT=90deg.C)	ps
tVW	Valid Data Simple window	0.575	-	UI

**Figure 5-6 SDIO (SDR104) Clock Signal Timing Diagram**

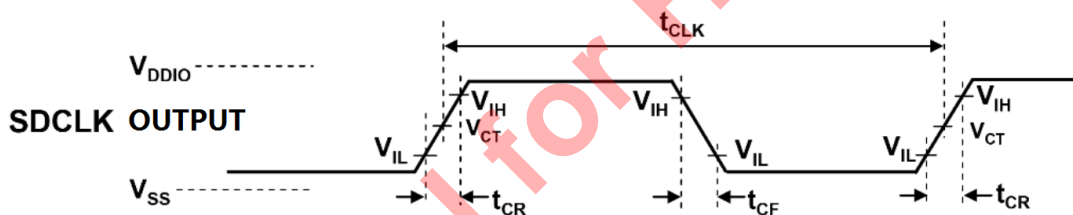

**Table 5-11 SDIO (SDR104) Clock Timing Specification**

Symbol	Parameter (SDR104 Mode)	Min	Max	Unit
tCLK	clock period Data Transfer Mode (PP)	4.8	-	ns
Duty	Clock Duty	30	70	%
tCR	clock rise time	-	0.96	ns
tCF	clock fall time	-	0.96	ns

Figure 5-7 SDIO (SDR104) Output Timing Diagram

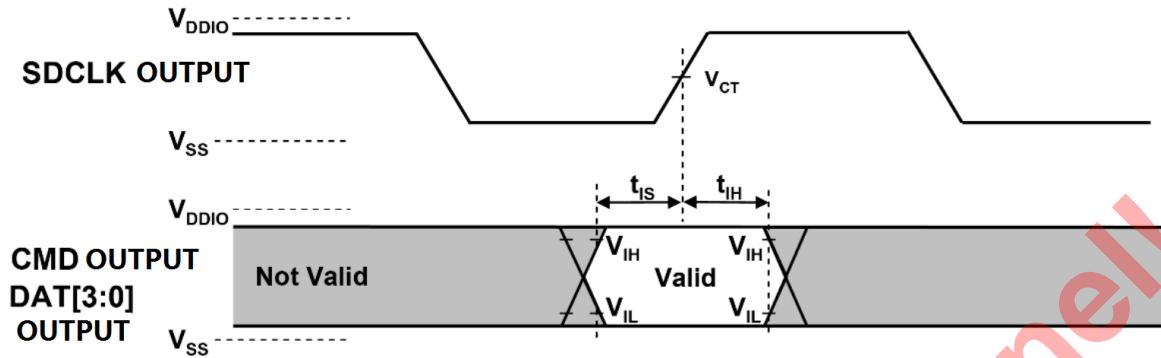

Table 5-12 SDIO (SDR104) Output Timing Specification

Inputs CMD, DAT (referenced to CLK)				
Symbol	Parameter	Min	Max	Unit
tIS	input set-up time	1.4	-	ns
tIH	input hold time	0.8	-	ns

**Note**

SD card interface uses SDIO protocol.

**5.7.3 NAND Timing Specification**

Nand timing specifications are shown as below.

Figure 5-8 Async Waveform for Command/Address/Data Output Timing

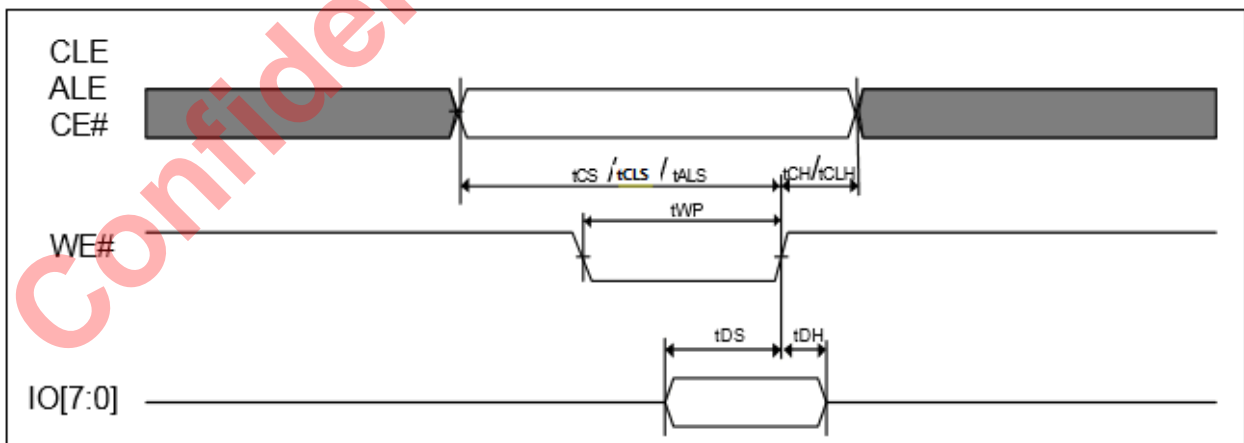



Figure 5-9 Async Waveform for Address Output Cycle

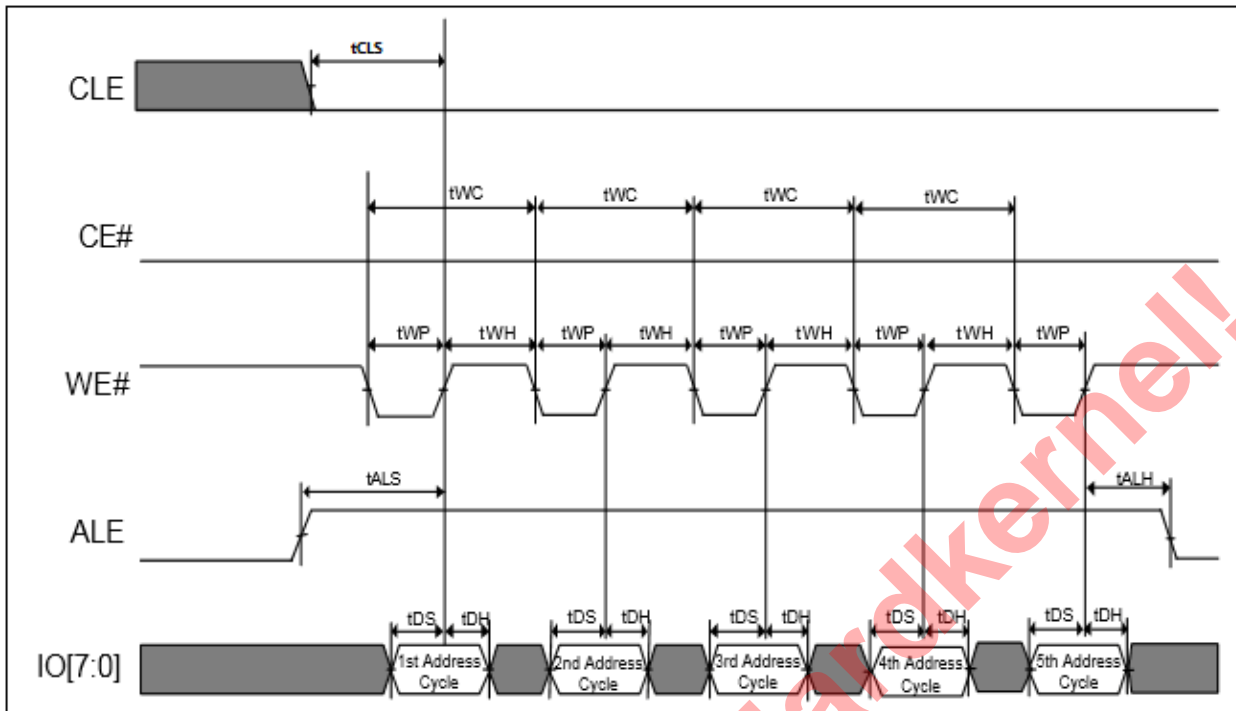

Figure 5-10 Async Waveform for Sequential Data Read Cycle(After Read)-EOD Mode

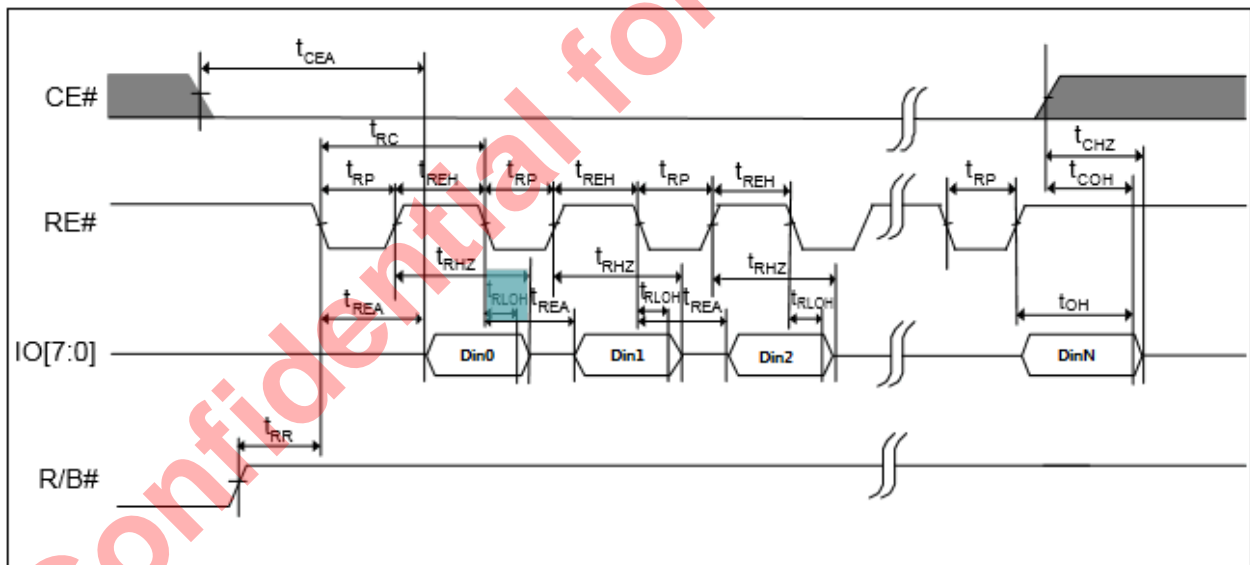

Table 5-13 Nand Timing Specifications

Symbol	Parameter (- Asynchronous) (- mode 5)	Min	Max	Unit
tCLS	CLE setup time	10	-	ns
tCLH	CLE hold time	5	-	ns
tALS	ALE setup	10	-	ns

Symbol	Parameter (- Asynchronous) (- mode 5)	Min	Max	Unit
tALH	ALE hold	5	-	ns
tDS	Data setup time	7	-	ns
tDH	Data hold time	5	-	ns
tWC	WE# cycle time	20	-	ns
tWP	WE# pulse width	10	-	ns
tWH	WE# high hold time	7	-	ns
tREA	RE# access time	-	16	ns
tOH	Data output hold time	15	-	ns
tRLOH	RE#-low to data hold time (EDO)	5	-	ns
tRP	RE# pulse width	10	-	ns
tREH	RE# high hold time	7	-	ns
tRC	RE# cycle time	20	-	ns

### 5.7.4 SPICC Timing Specification

Figure 5-11 SPICC Timing Diagram

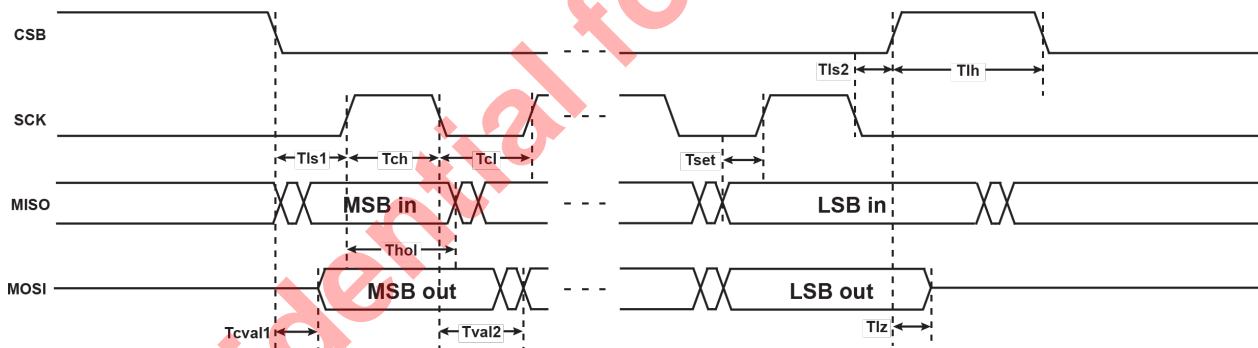

Table 5-14 SPICC Master Timing Specification

Symbol	Description	Min.	Max.	Unit
fCLK	Clock Frequency	1	80	MHz
TCH	Clock high time	5		ns
TCL	Clock low time	5		ns
TLS1	CS fall to First Rising CLK Edge	50		ns
TSET	Data input Setup Time	4		ns

Symbol	Description	Min.	Max.	Unit
THOL	Data input Hold Time	4		ns
TLH	Minimum idling time between transfers (- minimum ss high time)	5		ns

### 5.7.5 SPIFC Timing Specification

Figure 5-12 SPIFC Serial Input Timing Diagram

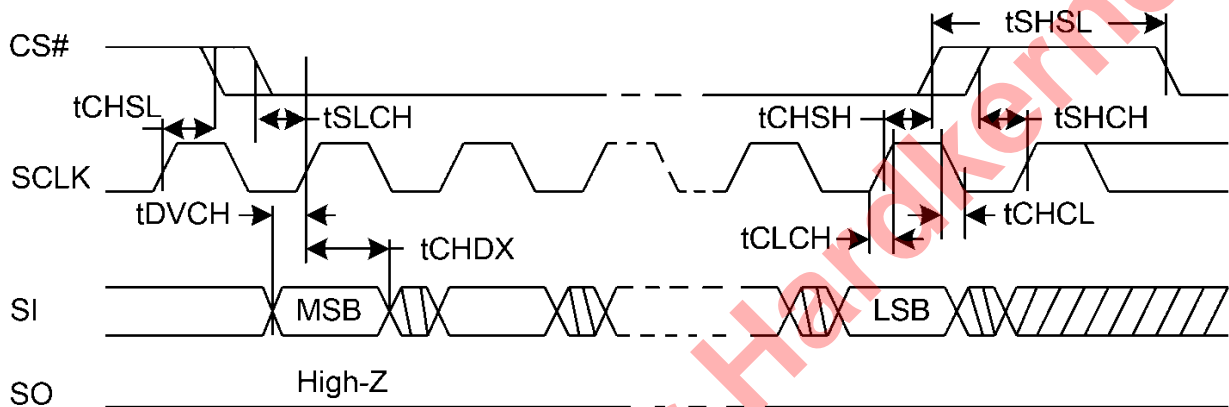

Figure 5-13 SPIFC Out Timing Diagram

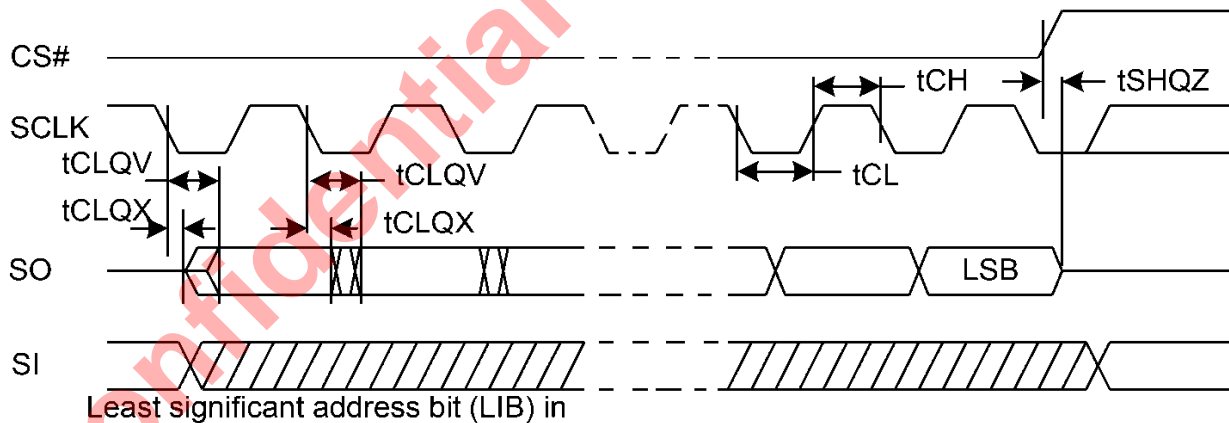

Table 5-15 SPIFC Master Timing Specification

Symbol	Parameter (Clock 41.7MHz)	Min	Max	Unit
fRSCLK	Clock Frequency for READ instructions		50	Mhz
tCH	Clock High Time	8		ns
tCL	Clock Low Time	8		ns

Symbol	Parameter (Clock 41.7MHz)	Min	Max	Unit
tCLCH	Clock Rise Time (- peak to peak)	0.1		V/ns
tCHCL	Clock Fall Time (- peak to peak)	0.1		V/ns
tSLCH	CS# Active Setup Time (relative to SCLK)	4	-	ns
tCHSH	CS# Active Hold Time (relative to SCLK)	4	-	ns
tDVCH	Data In Setup Time	2	-	ns
tCHDX	Data In Hold Time	3	-	ns
tSHQZ	Output Disable Time (relative to CS#)		8	ns
tCLQV	Clock Low to Output Valid		6	ns
tCLQX	Output Hold Time	1		ns

### 5.7.6 Ethernet Timing Specification

Figure 5-14 Management Data Timing Diagram

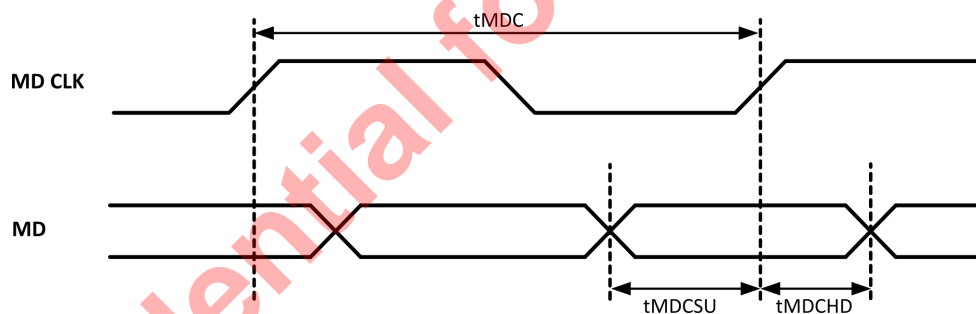

Table 5-16 Management Data Timing Specification

Symbol	Description	Min.	Typ.	Max.	Unit	Notes
tMDC	MDC clock Period	400	500		ns	From MAC
tMDCSU	Setup time to rising edge of MDC	10			ns	
tMDCHD	Hold time to rising edge of MDC	10			ns	

Figure 5-15 RMII Timing Diagram

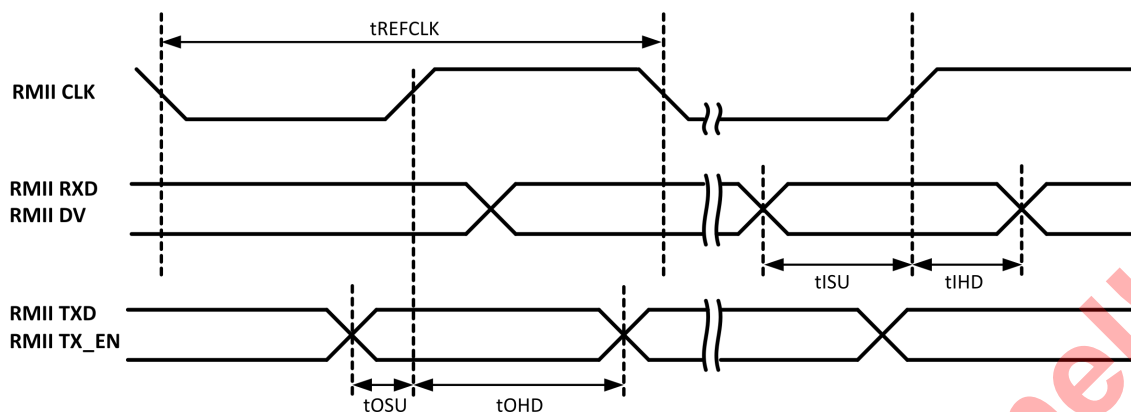
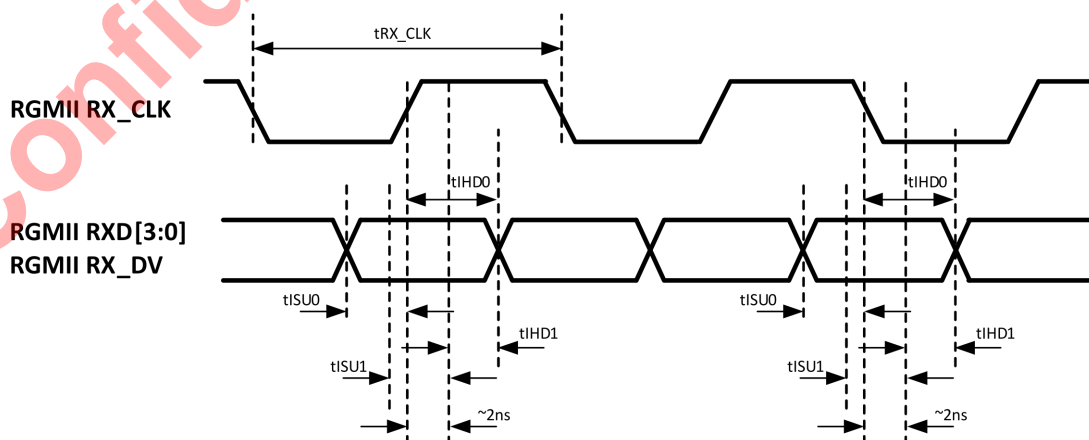

Table 5-17 RMII Timing Specification

Symbol	Description	Min.	Typ.	Max	Unit	Notes
$t_{REFCLK}$	RMII clock period		20		ns	50MHz from PHY
$t_{OSU}$	TXD & TX_EN setup time to rising edge of RMII clock	1.8	10		ns	To PHY
$t_{OHD}$	TXD & TX_EN hold time to rising edge of RMII clock	1.4	10		ns	To PHY
$t_{ISU}$	RXD & DV setup time to rising edge of RMII clock	1.0	10		ns	From PHY
$t_{IHD}$	RXD & DV hold time to rising edge of RMII clock	1.0	10		ns	From PHY

Figure 5-16 RGMII Receive Timing Diagram



**Table 5-18 RGMII Receive Timing Specification**

Symbol	Description	Min.	Typ.	Max	Unit	Notes
tRX_CLK	RGMII RX_CLK clock period		8		ns	125MHz from PHY
tSETUP	RXD[3:0] & RX_DV setup time (PHY internal delay enabled)	1.2			ns	From PHY
tHOLD	RXD[3:0] & RX_DV hold time (PHY internal delay enabled)	1.2			ns	From PHY
tSKEW	RXD[3:0] & RX_DV skew between these 5 signals (PHY internal delay disabled)	-0.5		0.5	ns	From PHY

When PHY internal delay is enabled, check setup/hold timing.

When PHY internal delay is disabled, check signal skew.

**Figure 5-17 RGMII Transmit Timing Diagram**

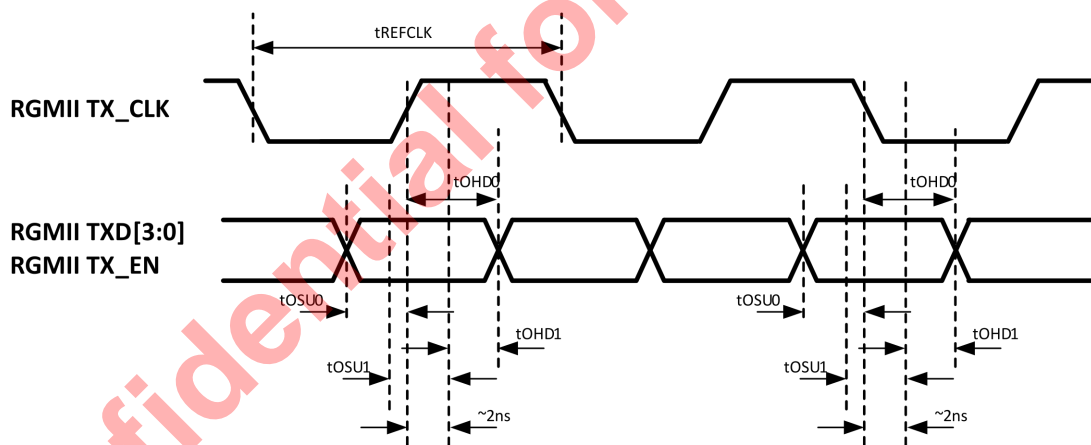

**Table 5-19 RGMII Transmit Timing Specification**

Symbol	Description	Min.	Typ.	Max	Unit	Notes
tTX_CLK	RGMII TX_CLK clock period		8		ns	125MHz to PHY
tOSU	TXD & TX_EN setup time to rising edge of RGMII clock (no clock delay added)	1			ns	From PHY

Symbol	Description	Min.	Typ.	Max	Unit	Notes
	TXD & TX_EN setup time to rising edge of RGMII clock (clock delay added)	-0.9			ns	From PHY
tOHD	RXD & DV hold time to rising edge of RGMII clock (no clock delay added)	0.8			ns	From PHY
	RXD & DV hold time to rising edge of RGMII clock (clock delay added)	2.7			ns	From PHY

### 5.7.7 Audio Timing Specification

There are two modes for the audio I2S/TDM interface: Master mode and Slave mode, as shown below.

Figure 5-18 I2S/TDM Timing Diagram, Master Mode

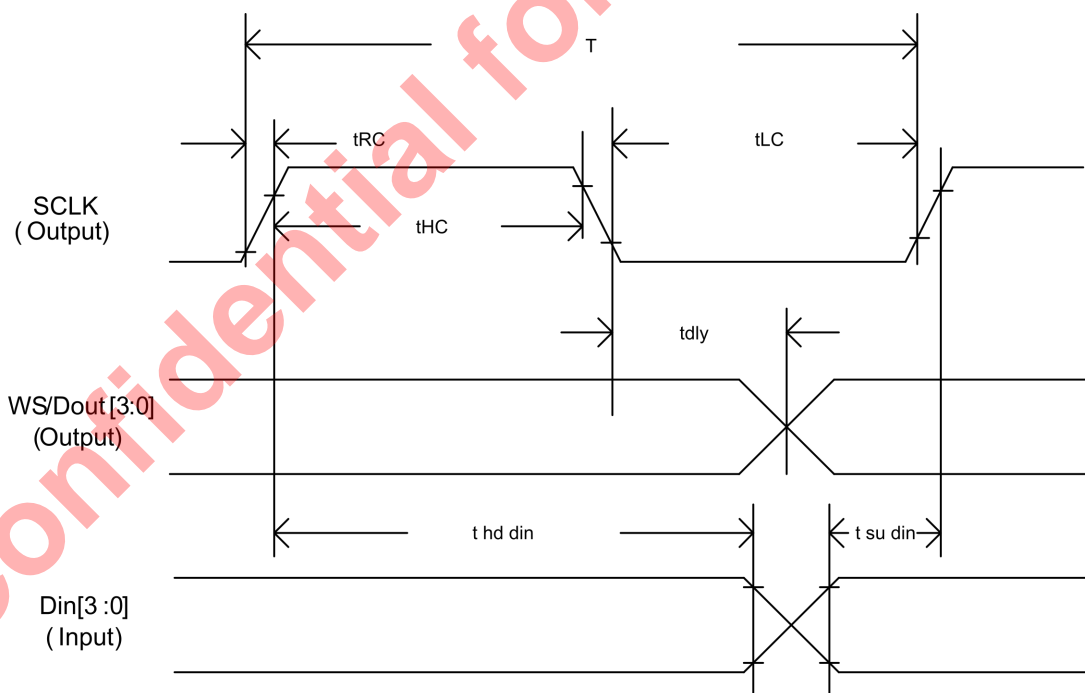

**Table 5-20 Audio I2S/TDM Timing Specification, Transmitter, Master Mode**

Transmitter (master mode)					
Symbol	Parameter	Min	Typ	Max	Unit
T	Clock period	10			ns
tHC	High level of SCLK	0.4			T
tLC	Low level of SCLK	0.4			T
tRC	Edge time of SCLK			0.8	ns
tdly	Delay from SCLK to WS	-2	3	5	
tsuin	Setup time of Din	4			ns
thdin	Hold time of Din	4			ns

**Note**

Measure Point refers to VIH, ViL parameter of Normal GPIO Specifications.

**Figure 5-19 2S/TDM Timing Diagram, Slave Mode**

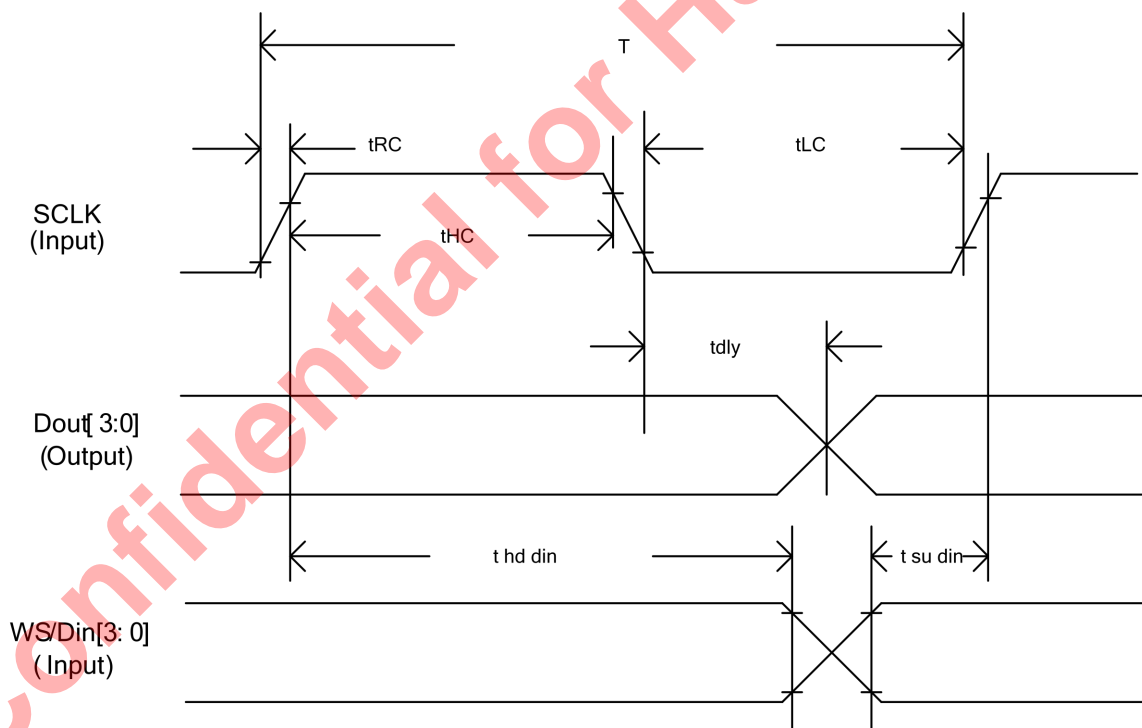

Transmitter (slave mode)					
Symbol	Parameter	Min	Typ	Max	unit
T(out)	Clock period	40			ns
T(in)	Clock period	10			ns



Transmitter (slave mode)					
Symbol	Parameter	Min	Typ	Max	unit
tHC	High level of SCLK	0.4			T
tLC	Low level of SCLK	0.4			T
tRC	Edge time of SCLK			0.8	ns
tsu in	Setup time of WS/Din	4			ns
thd in	Hold time of WS/Din	4			ns
tdly	Delay between SCLK and Dout	2	12	15	ns

**Note**

Measure Point refers to VIH, ViL parameter of Normal GPIO Specifications.

### 5.7.8 PDM Timing Specification

Figure 5-20 PDM Timing Diagram

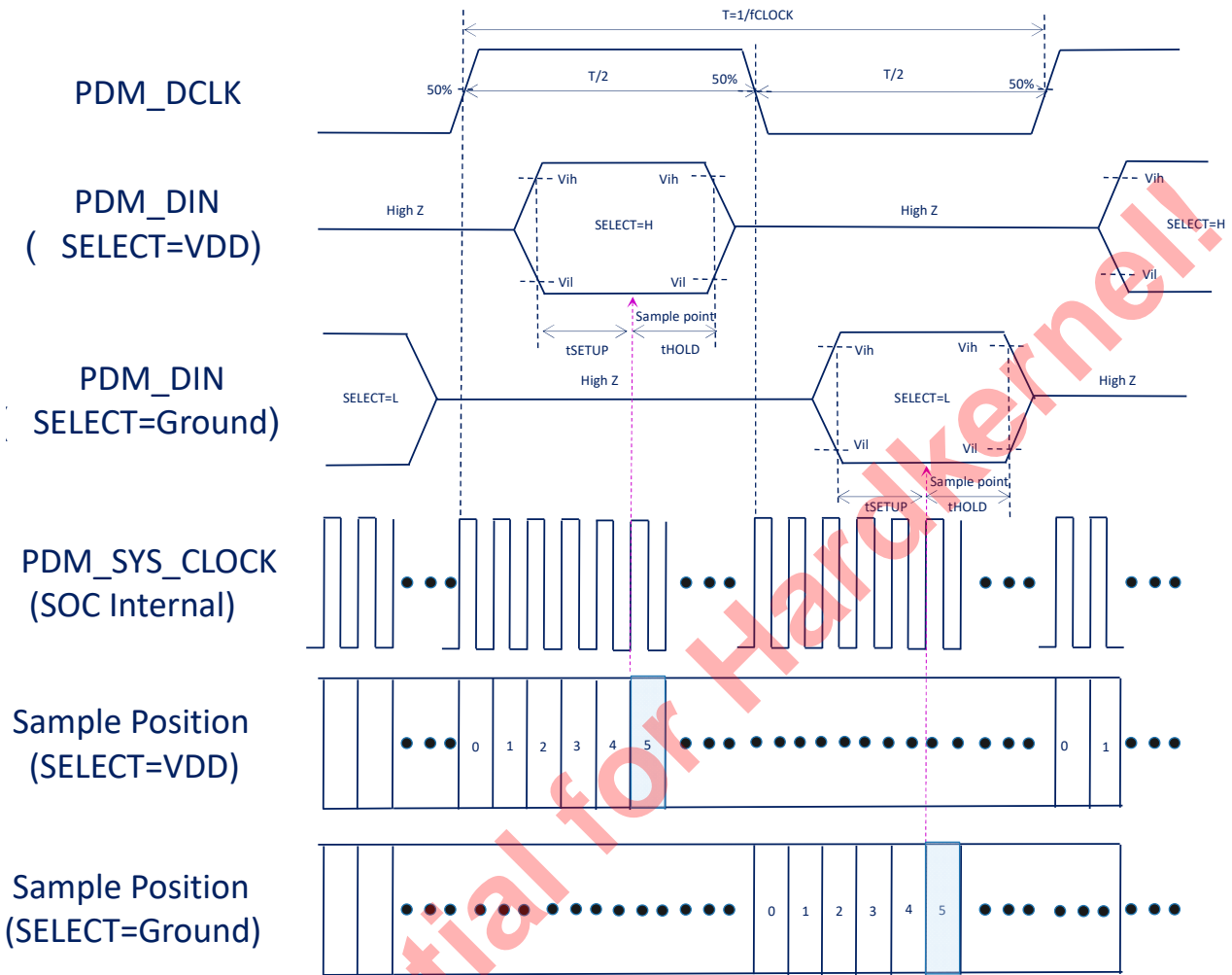

Table 5-21 PDM Timing Specification

Parameter	Symbol	Min.	Typ.	Max.	Units.
PDM clock period	tDCLK	200			ns
PDM clock duty cycle	tHIGH/tLOW	48%		52%	tDCLK
PDM Data setup time	tSETUP	20			ns
PDM Data hold time	tHOLD	20			ns
Sys clock period	tSYSCLK	5	7.5		ns

**Note**

1. Default PDM\_SYS\_CLOCK=133MHz.
2. For Sample position □ please refer to PDM register PDM\_CHAN\_CTRL, PDM\_CHAN\_CTRL1.

## 5.7.9 UART Timing Specification

Figure 5-21 UART Timing Diagram

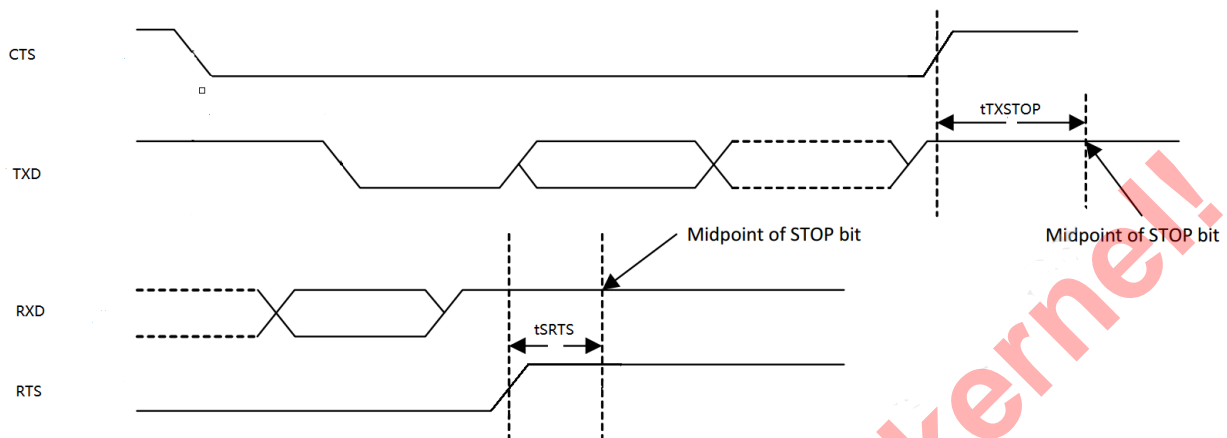

Table 5-22 UART Timing Specification

Parameter	Symbole	Min.	Max.	Units.
Delay time, CTS high before midpoint of stop bit	tTXSTOP	-	0.5	Bit Periods
Delay time, midpoint of stop bit to RTS high	tSRTS	-	0.5	Bit Periods

## 5.8 Power On Config

3 Boot pins are used as power on config (POC) pins, to set the booting sequence.

POC setting is latched at the rising edge of reset signal.

3 POC pins are all pull high internal, CPU will try to boot from nand/eMMC first, if fails then try to boot from SD CARD, still fails then try to boot from USB (PC).

External 4.7K ohm pull down resistors can be used to change the POC setting. The resistors should be placed on right location, avoid stubs on high speed signals.

The SoC's Power On Configuration is listed as following:

Table 5-23 Power On Configuration Pin Table

POC	Boot Pin	Name	Pull low	Pull high
POC_0	Boot_4	SPI NAND First	SPI NAND boot first	Default sequence
POC_1	Boot_5	USB First	USB boot first	Default sequence
POC_2	Boot_6	SPI NOR First	SPI NOR first	Default sequence

Table 5-24 Booting Sequence Diagram

No.	POC_0 (SPI_ NAND)	POC_1 (USB_ BOOT)	POC_2 (SPI_NOR, eMMC/ NAND )	1st Boot device	2nd Boot device	3rd Boot device	4th Boot device
1	0	0	0	USB (short delay)	SPI_NOR	NAND/ eMMC	SD Card
2	0	0	1	USB (short delay)	NAND/ eMMC	SD Card	-
3	0	1	0	SPI_NOR	NAND/ eMMC	SD Card	USB
4	0	1	1	SPI_NAND	NAND/ eMMC	USB	-
5	1	0	0	USB (short delay)	SPI_NOR	NAND/ eMMC	SD Card
6	1	0	1	USB (short delay)	NAND/ eMMC	SD Card	-
7	1	1	0	SPI_NOR	NAND/ eMMC	SD Card	USB
8	1	1	1	NAND/ eMMC	SD Card	USB	-

**Note**

If GPIOC is not work as SDIO port, please do not pull CARD\_DET(GPIOC\_6) low when system booting up, to avoid romcode trying to boot from SD CARD.

## 5.9 Power On Reset

The POR (Power On Reset) monitors VDDIO\_AO power voltage and compares it to a threshold Voltage.

RESET\_N pin is low (SOC is reset mode) when VDDIO\_AO is below threshold,

Force SOC enter reset mode via key to GND serial 100R resitor.

**Note**

1. Place 1nF capacitors on RESET\_N Pin.
2. VDDIO\_AO power pin is only support 3.3V, not allow to power off in sleep mode.

Figure 5-22 POR Wave Diagram

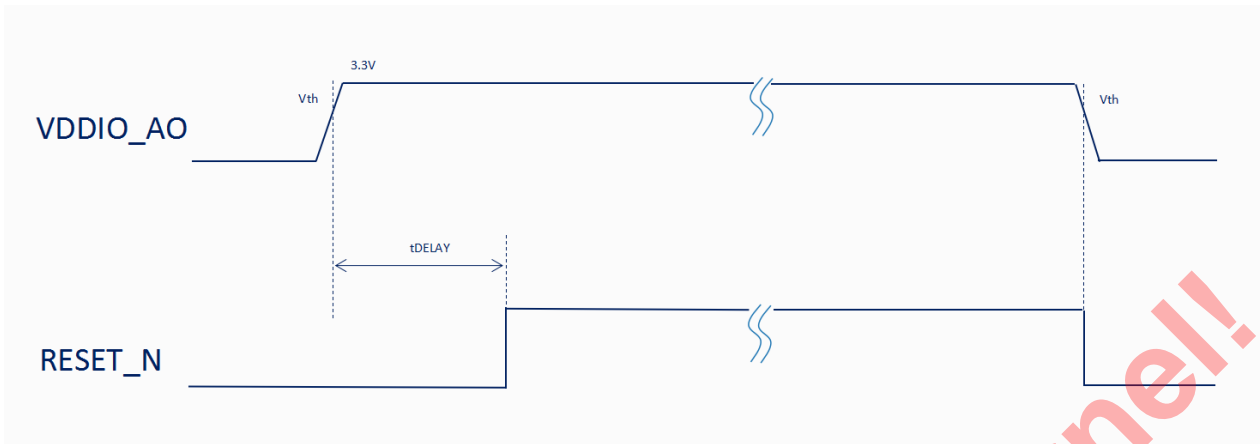
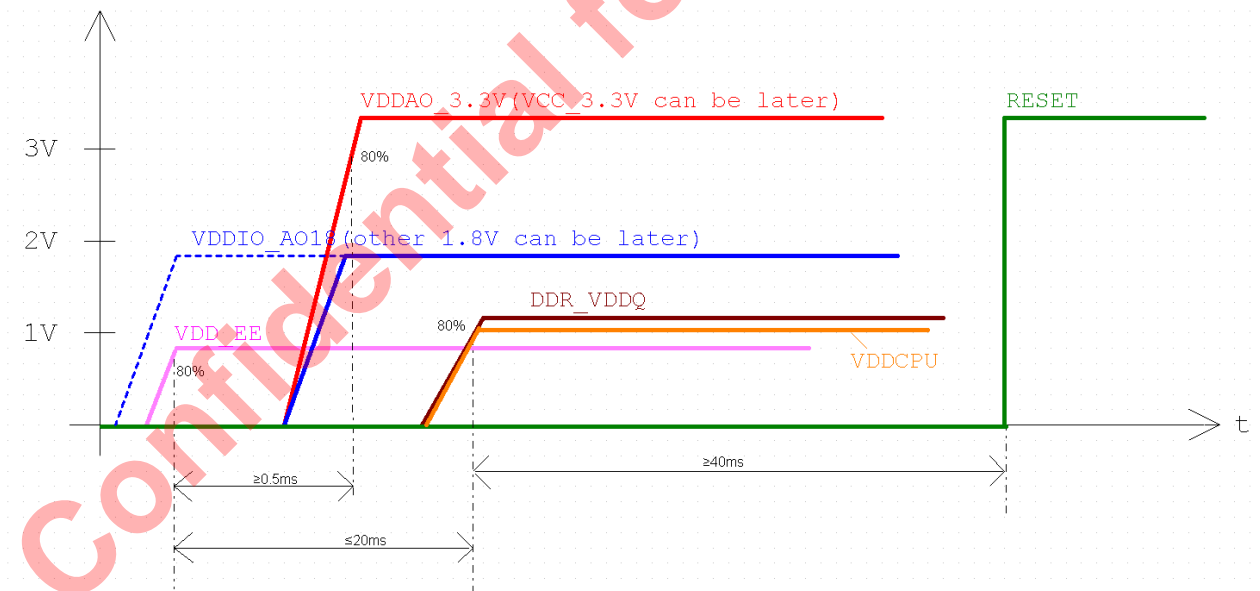

Table 5-25 POR Specifications

Parameter	Symbol	Min.	Typ.	Max.	Unit
Reset threshold voltage	Vth	2.6	2.7	2.8	V
Reset delay time	tDELAY	109	170	218	ms

### 5.10 Recommended Power on Sequence

Example power on sequence:



**Note**

1. All test values refer to 80% of typical power voltage.
2. VDDAO\_3.3V & VCC3.3V should ramp up > 0.5ms later than VDD\_EE.
3. All power sources should get stable within 20ms (except for DDR\_VDDQ).
4. No sequence requirement between VDDCPU & DDR\_VDDQ and other power source.
5. VDDIO\_AO18 should ramps up earlier than or at the same time with VDDAO\_3.3V & VCC3.3V, VDDAO\_3.3V & VCC3.3V should never be 2.5V higher than VDDIO\_AO18.
6. In some designs, VDDCPU & VDD\_EE are merged to VCC\_CORE, the power on sequence should be same as VDD\_EE.
7. RESET\_n should keep low for at least 40ms after power up (except DDR\_VDDQ).

Please refer to reference schematics.

## 5.11 Power Consumption

**Note**

Value listed here is estimated typical max value tested. Enough margin in circuit needs to be reserved.

Symbol	Maximum Current	Note
VDDCPU	3 A	-
VDD_EE	1.9 A	-
VDDQ	900 mA	VDDQ Maximum current does not include DRAM current. Peak SOC + DRAM VDDQ current is up to 1.5A with 2 ranks DDR3

Symbol	Typical Current	Maximum Current	Note
AVDD0V8_USB_PCIE	19.2mA	58mA	
AVDD0V8_HDMI	17.2mA	23mA	At 6 Gbps mode
AVDD_DDRPLL	4.1mA	6mA	
AVDD18_ENET	35.5mA	40mA	-
AVDD18_AO	25.9	128.5	Max 130 mA when programming EFUSE
AVDD18_AUDIO	4mA	6.6mA	-
AVDD18_PCIE	31.6mA	40mA	At 5 Gbps mode
AVDD18_HDMI	9.3mA	15.3mA	-
AVDD18_CVBS	39.8mA	48mA	-
AVDD18_USB	18.2mA	25mA	-
AVDD33_USB	0.3mA	2mA	-
VDDIO	-	-	Note

**Note**

VDDIO=1.8V, DS=3, output 200MHz clock:

1. IO pad itself consumes about 1.4mA.
2. Driving a 55ohm trace with length of 50mm and width of 0.1mm will consumes about 2.8mA additional current (low impedance trace consumes more power)
3. Base on #2, add 5pF cap will consumes about 1.8mA additional current, total about 6mA
4. When VDDIO=3.3V, GPIO consumes about 70% higher current, about 13mA.
5. Internal & external pull down resistor consumes more current.

## 5.12 Storage and Baking Conditions

The processor is moisture-sensitive device of MSL level 3, defined by IPC/JEDEC J-STD-020. Please follow the storage and backing guidelines.

1. Calculated shelf life in sealed bag: 12 months at <math><40^{\circ}\text{C}</math> and <math><90\%</math> relative humidity (RH).
2. After bag is opened, devices that will be subjected to reflow solder or other high temperature process must be
  - a. Mounted with 168 hours of factory conditions  $\leq 30^{\circ}\text{C}/60\% \text{RH}$ , or
  - b. Stored per J-STD-033
3. Devices require bake, before mounting, if Humidity Indicator Card reads >10%.
4. If baking is required, refer IPC/JEDEC J-STB-033 for baking process.

# 6 Mechanical Dimensions

The SoC comes in a 45\*45 ball matrix FCBGA RoHS package. The mechanical dimensions are given in millimeters as the following figures.

Figure 6-1 Dimensions

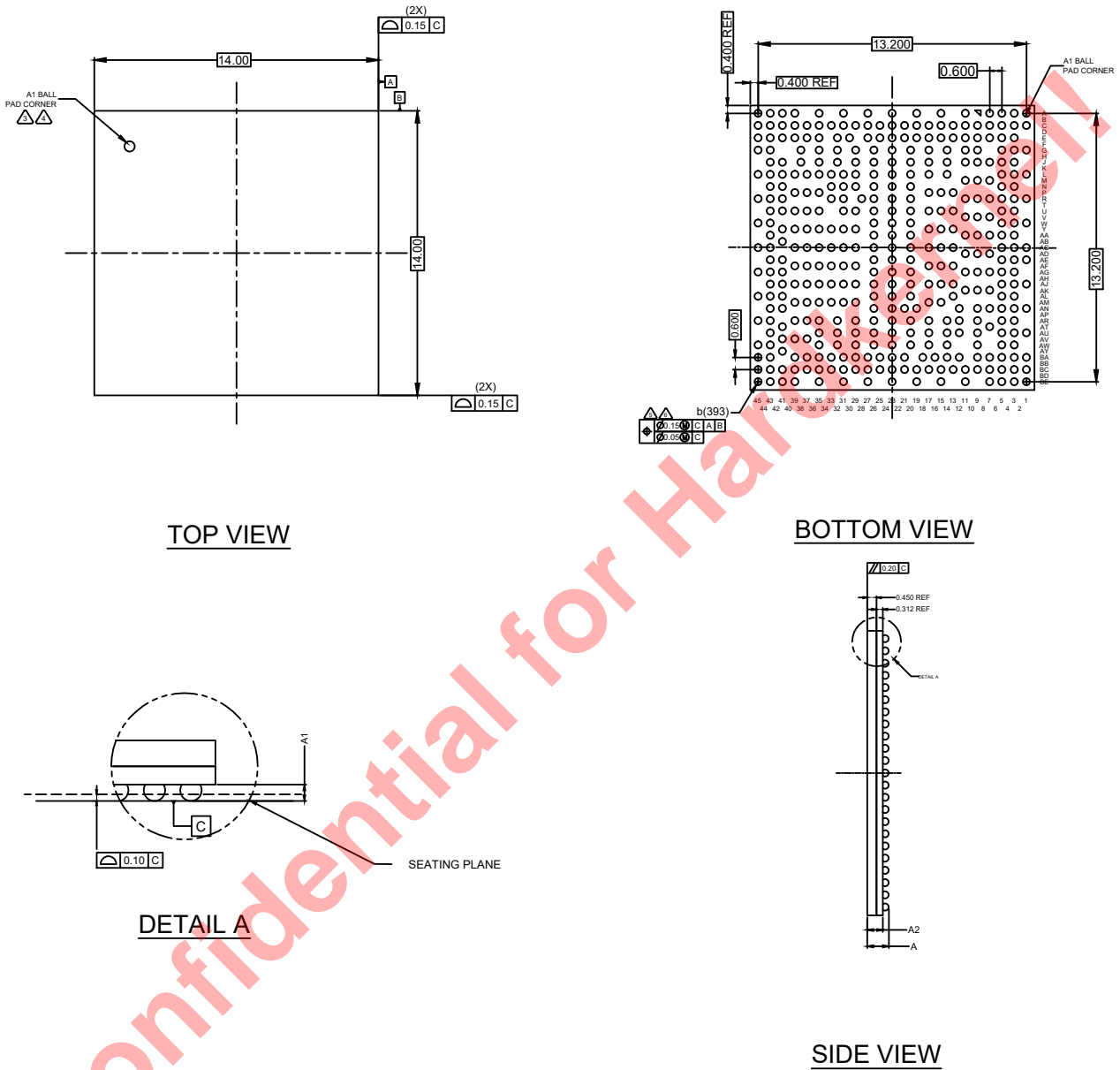

Figure 6-2 Dimension Specification

DIMENSION	MINIMUM	NOMINAL	MAXIMUM
A	0.952	1.032	1.112
A1	0.230	0.270	0.310
A2	0.702	0.762	0.822
b	0.300	0.350	0.400
NUMBER OF BALL 393			



## 7 System

This chapter describes the S905X3 system architecture.

### 7.1 Memory Map

Memory map of S905X3 is listed in the following table.

**Table 7-1 Memory Map**

START	END	REGION (NORMAL)
FFFF0000	FFFFFFFF	a55_rom
FFFE8000	FFFEFFFF	reserved
FFFA0000	FFFE7FFF	ahb_sram
FFE80000	FFF9FFFF	reserved
FFE40000	FFE7FFFF	mali
FFE0D000	FFE3FFFF	reserved
FFE0B000	FFE0CFFF	reserved
FFE09000	FFE0AFFF	usbctrl
FFE07000	FFE08FFF	emmcC
FFE05000	FFE06FFF	emmcB
FFE03000	FFE04FFF	emmcA
FFE02000	FFE02FFF	bt656
FFE01000	FFE01FFF	htx_hdcp22
FFE00000	FFE00FFF	reserved
FFD27000	FFDFFFFF	reserved
FFD26000	FFD26FFF	async_fifo3
FFD25000	FFD25FFF	sc
FFD24000	FFD24FFF	uart0
FFD23000	FFD23FFF	uart1
FFD22000	FFD22FFF	uart2
FFD21000	FFD21FFF	reserved
FFD20000	FFD20FFF	reserved
FFD1F000	FFD1FFFF	i2c_m0
FFD1E000	FFD1EFFF	i2c_m1
FFD1D000	FFD1DFFF	i2c_m2
FFD1C000	FFD1CFFF	i2c_m3
FFD1B000	FFD1BFFF	pwm_ab
FFD1A000	FFD1AFFF	pwm_cd
FFD19000	FFD19FFF	pwm_ef
FFD18000	FFD18FFF	msr_clk
FFD17000	FFD17FFF	reserved

START	END	REGION (NORMAL)
FFD16000	FFD16FFF	reserved
FFD15000	FFD15FFF	spicc_1
FFD14000	FFD14FFF	spifc
FFD13000	FFD13FFF	spicc_0
FFD12000	FFD12FFF	reserved
FFD11000	FFD11FFF	reserved
FFD10000	FFD10FFF	reserved
FFD0F000	FFD0FFFF	isa
FFD0E000	FFD0EFFF	parser
FFD0D000	FFD0DFFF	parser1
FFD0C000	FFD0CFFF	sana
FFD0B000	FFD0BFFF	stream
FFD0A000	FFD0AFFF	async_fifo
FFD09000	FFD09FFF	async_fifo2
FFD08000	FFD08FFF	assist
FFD07000	FFD07FFF	
FFD06000	FFD06FFF	stb
FFD05000	FFD05FFF	aiffo
FFD04000	FFD04FFF	reserved
FFD03000	FFD03FFF	reserved
FFD02000	FFD02FFF	reserved
FFD01000	FFD01FFF	reset
FFD00000	FFD00FFF	reserved
FFC08000	FFC07FFF	reserved
FFC00000	FFC07FFF	gic
FFB00000	FFB07FFF	gpv
FF950000	FF947FFF	reserved
FF940000	FF947FFF	ge2d
FF900000	FF937FFF	vpu
FF80B000	FF80AFFF	reserved
FF80A000	FF80AFFF	ao_mailbox
FF809000	FF809FFF	sar_adc
FF808000	FF808FFF	ir_dec
FF807000	FF807FFF	pwm_ab
FF806000	FF806FFF	i2c_s
FF805000	FF805FFF	i2c_m
FF804000	FF804FFF	uart2

START	END	REGION (NORMAL)
FF803000	FF803FFF	uart
FF802000	FF802FFF	pwm_cd
FF801000	FF801FFF	reserved
FF800000	FF800FFF	rti
FF664000	FF7FFFFF	reserved
FF663800	FF663FFF	
FF663000	FF6637FF	
FF662000	FF662FFF	eqdrc
FF661C00	FF661FFF	resampleA
FF661800	FF661BFF	vad
FF661400	FF6617FF	locker
FF661000	FF6613FF	pdm
FF660000	FF660FFF	audiotop
FF652000	FF65FFFF	reserved
FF650000	FF651FFF	
FF64E000	FF64FFFF	reset_sec
FF64C000	FF64DFFF	eth_phy
FF64A000	FF64BFFF	
FF648000	FF649FFF	pcie_A
FF646000	FF647FFF	pcie_phy
FF644000	FF645FFF	
FF642000	FF643FFF	
FF640000	FF641FFF	pdm
FF63E000	FF63FFFF	dma
FF63C000	FF63DFFF	hiu
FF63A000	FF63BFFF	usbphy21
FF638000	FF639FFF	dmc
FF636000	FF637FFF	usbphy20
FF635000	FF635FFF	reserved
FF634C00	FF634FFF	ts_ddr
FF634800	FF634BFF	ts_pll
FF634400	FF6347FF	periphs_reg
FF634000	FF6343FF	reserved
FF632000	FF633FFF	acodec
FF630000	FF631FFF	efuse
FF620000	FF62FFFF	dos
FF610000	FF61FFFF	wavel

START	END	REGION (NORMAL)
FF600000	FF60FFFF	hdmitx
FF500000	FF5FFFFFFF	usb0
FF400000	FF4FFFFFFF	usb1
FF3F0000	FF3FFFFFFF	eth
FF140000	FF3EFFFF	reserved
FF100000	FF13FFFF	NN
FF000000	FF0FFFFFFF	reserved
FE000000	FEFFFFFFF	ddr_ctrl
FC000000	FDFFFFFFF	pcie_axi
FA000000	FBFFFFFFF	reserved
F6000000	F9FFFFFFF	flash
F5800000	F5FFFFFFF	a55_dbg
0	F57FFFFFFF	ddr

## 7.2 Power Domain

The following figure shows the power domain of S905X3.

Figure 7-1 Power Domain

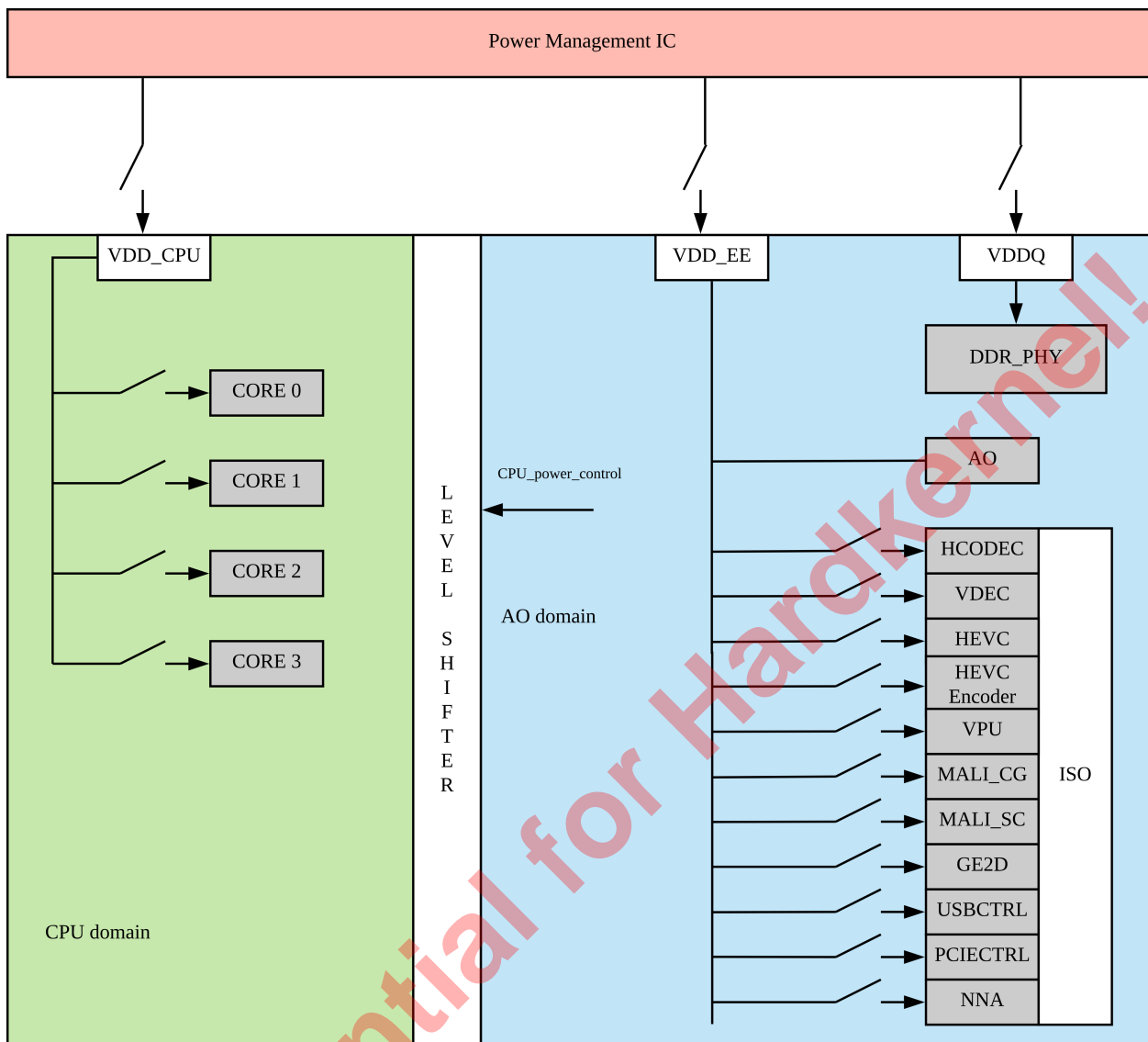

**Note**

- VDD\_AO and VDD\_EE are merged to reduce SOC area and power consumption, the isolation design of AO and EE power domain is kept for compatibility.

**7.2.1 Top Level Power Domains**

The power supplies for the different domains must follow a specific power supply order:

- The A55 can't be powered without the EE domain.
- The EE domain can't be powered on without the AO domain.

Please read the following table from left to right and then right to left, that's the essential power up/down sequence for the entire chip.

	Always On	EE Domain		A55 domain			
		Logic	EE Logic	domains	L3 Cache	CPU0	CPU1
STATE 0 All off	Off	The EE domain must be OFF if the AO domain is off		The A55 domain must be off if the EE domain is OFF			
STATE 1 Hibernate: Only the Always on Domain is powered	ON	Off	The Mali must be OFF is if the EE domain is off	The A55 domain must be off if the EE domain is OFF			
STATE 2 Always On/ EE only (for example audio applications or simple video applications that don't need the A5)	On	On	On or off as needed	Off	Off	Off	Off
STATE 3 Single PU	On	On	On or off as needed	All three must be enabled		Off	Off
STATE 4 2 CPU's	On	On	On or off as needed	All three must be enabled		On	Off
STATE 5 4 CPUs	On	On	On or off as needed	All three must be enabled		On	On

## 7.2.2 A55 Power Modes

The A55 domain is the last to power up and the first to power down. The A55 domain itself consists of a quad (4) CPUs (L1 inside), an L3 cache controller and an SCU. The A55 CPU boots with the SCU/L3 powered and CPU0 powered. After CPU0 boots, subsequent CPU's can be enabled and disabled independently of one another using the control bits described below. The most likely scenario would be for the CPU0 to be used for low load conditions, CPU0 and CPU1 to be used for medium load conditions and CPU0, 1, 2 and CPU3 to all be used for heavy load conditions. The flow-diagram below illustrates the transition to each legal state.

A55	CPU0	CPU1	CPU2	CPU3	A55_pwr
Domain Power Sleep bit AO_RTI_PWR_SYS_CPU_CNTL1 (1 = power off)	Bit[2]	Bit[4]	Bit[6]	Bit[8]	
Domain Power Acknowledge bit AO_RTI_PWR_SYS_CPU_CNTL1 AO_RTI_PWR_	Bit[16]	Bit[17]	Bit[18]	Bit[19]	
Output signal isolation bit AO_RTI_PWR_SYS_CPU_CNTL0 (1 = isolated)	Bit[0]	Bit[1]	Bit[2]	Bit[3]	Bit[12]

Figure 7-2 Power Sequence of A55

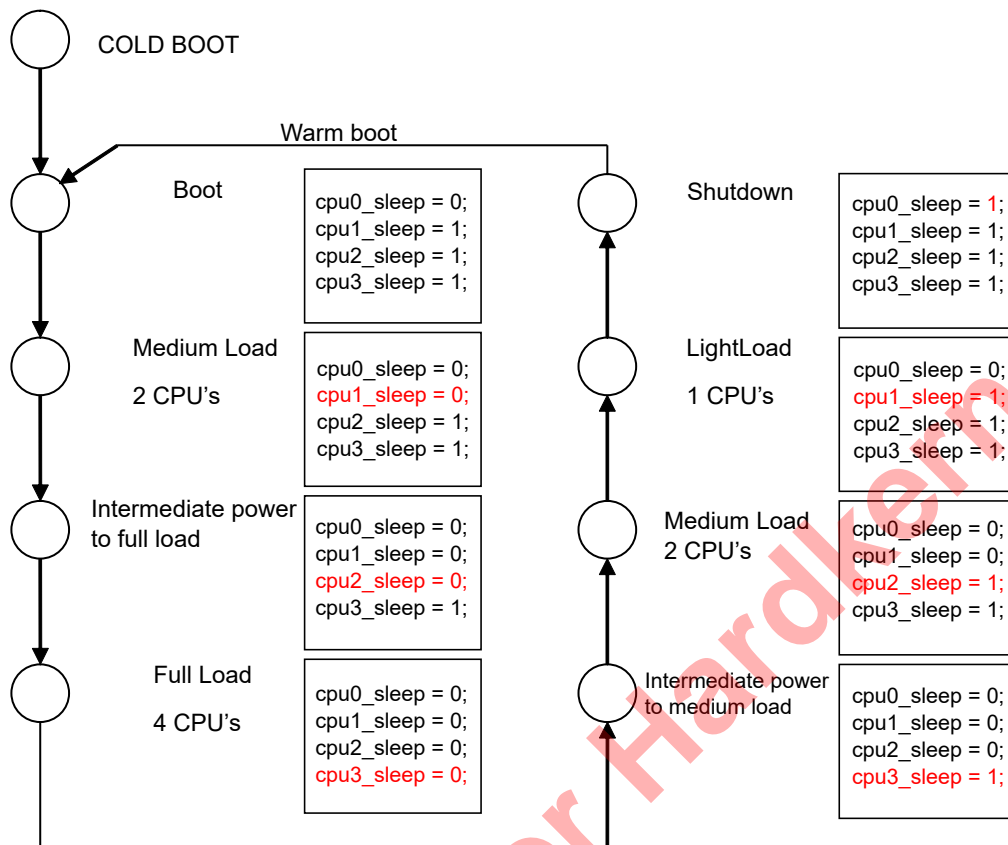

T02FC33

### 7.2.3 EE Top Level Power Modes

The EE domain consists of several sub-domains: DOS, VPU, Mali and GE2D, USBCTRL, PCIECTRL and NNA.

#### 7.2.3.1 DOS

The DOS module sits in the EE domain and has 4 distinct power domains, as following:

- VDEC1
- HEVC
- HCODEC
- HEVC Encoder

These should be powered up in sequence so as to reduce the surge currents. The module consists of both logic and memories. The logic and memories should be powered up/down with the clocks disabled. Each power domain in the DOS module is controlled by a single control bit. There is also an "acknowledge" bit that can be used to check if the power up/down condition is complete. The typical shutdown/power up time is typically less than 200nS.

Table 7-2 DOS Power Control Summary

	Register	VDEC	HEVC	HCODEC	HEVC Encoder
Domain Power Sleep (1 = power off)	AO_RTI_GEN_PWR_SLEEP0	Bit[1]	Bit[2]	Bit[0]	Bit[3]
Domain Power Acknowledge	AO_RTI_GEN_PWR_ACK0	Bit[1]	Bit[2]	Bit[0]	Bit[3]
Output signal isolation (1 = isolated)	AO_RTI_GEN_PWR_ISO0	Bit[1]	Bit[2]	Bit[0]	Bit[3]
Memory Power Down/Up 0 = powered on 1 = powered off		DOS_MEM_PD_VDEC	DOS_MEM_PD_HEVC	DOS_MEM_PD_HCODEC	DOS_MEM_PD_HEVC Encoder
Reset_n		DOS_SW_RESET0	DOS_SW_RESET3	DOS_SW_RESET1	DOS_SW_RESET4

### 7.2.3.2 VPU

The VPU is one large power domain even though it contains multiple video paths and the HDMI-TX module.

Table 7-3 Power &amp; Global Clock Control Summary

	Register/Bit
Domain Power Sleep bit 1 = power off	Bit[8] of AO_RTI_GEN_PWR_SLEEP0
Domain Power Acknowledge status 1 = module powered off	Bit[8] of AO_RTI_GEN_PWR_ACK0
Output Signal isolation bit 1 = Set isolation	Bit[8] of AO_RTI_GEN_PWR_SLEEP0
Memory Power Down/Up 0x00000000 = powered on 0xFFFFFFFF = powered off	HHI_VPU_MEM_PD_REG0 (bit[31:0]) HHI_VPU_MEM_PD_REG1 (bit[31:0]) HHI_VPU_MEM_PD_REG2 (bit[31:0]) HHI_VPU_MEM_PD_REG3 (bit[31:0]) HHI_VPU_MEM_PD_REG4 (bit[31:0]) HHI_MEM_PD_REG0 (bit[15:8])

### 7.2.3.3 Mali Power Modes

The Mali block sits within the EE domain and the Mali module itself has 3 distinct power domains:

- SC0 (VDD\_SC0)
- CG (VDD\_CG)
- GL (VDD)

The power on/down sequence is as follows:

- Power on sequence: CG -> SC0
- Power down sequence: SC0 -> CG



### 7.2.3.4 GE2D

The GE2D is one power domain including ge2d module.

**Table 7-4 Power & Global Clock Control Summary**

	Register/Bit
Domain Power Sleep bit 1 = power off	Bit[19] of AO_RTI_GEN_PWR_SLEEP0
Domain Power Acknowledge status 1 = module powered off	Bit[19] of AO_RTI_GEN_PWR_ACK0
Output Signal isolation bit 1 = Set isolation	Bit[19] of AO_RTI_GEN_PWR_SLEEP0
Memory Power Down/Up 0x00 = powered on 0xFF = powered off	HHI_MEM_PD_REG0 (bit[25:18])

### 7.2.3.5 USB CTRL

The USB\_COMB is one power domain including usb2 and usb3 controllers. USB phy is not included.

**Table 7-5 Power & Global Clock Control Summary**

	Register/Bit
Domain Power Sleep bit 1 = power off	Bit[17] of AO_RTI_GEN_PWR_SLEEP0
Domain Power Acknowledge status 1 = module powered off	Bit[17] of AO_RTI_GEN_PWR_ACK0
Output Signal isolation bit 1 = Set isolation	Bit[17] of AO_RTI_GEN_PWR_SLEEP0
Memory Power Down/Up 0x0 = powered on 0x3 = powered off	HHI_MEM_PD_REG0 (bit[31:30])

### 7.2.3.6 PCIE CTRL

The PCIE\_COMB is one power domain including pcie controllers. PCIE phy is not included.

**Table 7-6 Power & Global Clock Control Summary**

	Register/Bit
Domain Power Sleep bit 1 = power off	Bit[18] of AO_RTI_GEN_PWR_SLEEP0
Domain Power Acknowledge status 1 = module powered off	Bit[18] of AO_RTI_GEN_PWR_ACK0

	Register/Bit
Output Signal isolation bit 1 = Set isolation	Bit[18] of AO_RTI_GEN_PWR_SLEEP0
Memory Power Down/Up 0x0 = powered on 0xF = powered off	HHI_MEM_PD_REG0 (bit[29:26])

### 7.2.3.7 NNA

The NNA is one power domain including nna module.

**Table 7-7 Power & Global Clock Control Summary**

	Register/Bit
Domain Power Sleep bit 1 = power off	Bit[16] of AO_RTI_GEN_PWR_SLEEP0
Domain Power Acknowledge status 1 = module powered off	Bit[16] of AO_RTI_GEN_PWR_ACK0
Output Signal isolation bit 1 = Set isolation	Bit[16] of AO_RTI_GEN_PWR_SLEEP0
Memory Power Down/Up 0x00 = powered on 0xFF = powered off	HHI_NANOQ_MEM_PD_REG0 HHI_NANOQ_MEM_PD_REG1

### 7.2.4 Register Description

This section describes power/isolation/memory power down register summary.

For below registers the base address is 0xFF63C000.

Each register final address = BASE + address \* 4.

**Table 7-8 HHI\_MEM\_PD\_REG0 0x40**

Bit(s)	R/W	Default	Description
31~18	R/W	0x3FFF	Reserved
17~16	R/W	0x3	DDR memory PD
15~8	R/W	0xFF	HDMI memory PD
7~6	R/W	0x3	Reserved
5~4	R/W	0x3	Audio mem PD
3~2	R/W	0x3	Ethernet memory PD
1~0	R/W	0x3	resv

Table 7-9 HHI\_VPU\_MEM\_PD\_REG0 0x41

Bit(s)	R/W	Default	Description
31~30	R/W	0x3	sharpness
29~28	R/W	0x3	Deinterlacer – di_post
27~26	R/W	0x3	Deinterlacer – di_pre[1:0] – di_pre[3:2] in reg2
25~24	R/W	0x3	Disc memory
23~22	R/W	0x3	Afbc_dec1
21~20	R/W	0x3	Srsc
19~18	R/W	0x3	Vdin1
17~16	R/W	0x3	Vdin0
15~14	R/W	0x3	Osd
13~12	R/W	0x3	Scaler
11~10	R/W	0x3	Ofifo
9~8	R/W	0x3	Chroma
7~6	R/W	0x3	Vd2
5~4	R/W	0x3	Vd1
3~2	R/W	0x3	Osd2
1~0	R/W	0x3	Osd1

Table 7-10 HHI\_VPU\_MEM\_PD\_REG1 0x42

Bit(s)	R/W	Default	Description
31~30	R/W	0x3	Vd2_osd_sc
29~28	R/W	0x3	Ldim_stts
27~26	R/W	0x3	Lc_stts
25~24	R/W	0x3	Venci_int
23~22	R/W	0x3	Venc_l_top
21~20	R/W	0x3	Vencp_int
19~18	R/W	0x3	Vd2_scale
17~16	R/W	0x3	Afbc_dec0
15~14	R/W	0x3	Vpu_arb
13~12	R/W	0x3	Dolby1b
11~10	R/W	0x3	Dolby1a
9~8	R/W	0x3	Dolby0
7~6	R/W	0x3	Dolby_core3
5~4	R/W	0x3	vks
3~0	R/W	0x3	Viu2[3:0] – viu2[5:4] in reg2

Table 7-11 HHI\_VPU\_MEM\_PD\_REG3 0x43

Bit(s)	R/W	Default	Description
31~0	R/W	0xffffffff	Reserved

Table 7-12 HHI\_VPU\_MEM\_PD\_REG4 0x44

Bit(s)	R/W	Default	Description
31~6	R/W	-	Resv
5~4	R/W	0x3	Mali_afbce
3~0	R/W	0xf	Axi_arbiter

Table 7-13 HHI\_VPU\_MEM\_PD\_REG2 0x4d

Bit(s)	R/W	Default	Description
31~26	R/W	0x3	Resv
25~24	R/W	0x3	Deinterlacer – di_pre[3:2]
23~22	R/W	0x3	Viu2[5:4]
21~20	R/W	0x3	Lut3d
19~18	R/W	0x3	ds
17~16	R/W	0x3	Vd2_offo
15~14	R/W	0x3	Prime_dolby_ram
13~12	R/W	0x3	Osd_bld34
11~10	R/W	0x3	Vd1sc
9~8	R/W	0x3	Mali_afbcd
7~6	R/W	0x3	Osd4
5~4	R/W	0x3	Osd3
3~2	R/W	0x3	Reserved
1~0	R/W	0x3	waterMark

Table 7-14 HHI\_AUDIO\_MEM\_PD\_REG0 0x45

Bit(s)	R/W	Default	Description
31~4	R/W	0x3	no use
27-26			toddr_E memory pd
25-24			frddr_E memory pd
23-22			toddr_C memory pd
21-20			frddr_D memory pd
19-18			toddr_D memory pd
17-16	R/W	0x3	toddr_A memory pd
15-14			VAD memory pd

Bit(s)	R/W	Default	Description
13-12			EQDRC memory pd
9-8			
7-6			frddr_C memory pd
5-4			frddr_B memory pd
3-2	R/W	0x3	frddr_A memory pd
1-0	R/W	0x3	toddr_B memory pd

For below registers:

Base address: 0xFF800000

Register address: 0xFF800000 + offset \* 4

**Table 7-15 AO\_RTI\_PWR\_SYS\_CPU\_CNTL0 0x38**

Bit(s)	R/W	Default	Description
31~5	R/W	0	resv
4	R/W		A55_pwr isolation
3~0	R/W	0xE	CPU cores 0~3 isolation

**Table 7-16 AO\_RTI\_PWR\_SYS\_CPU\_CNTL1 0x39**

Bit(s)	R/W	Default	Description
31~20	R	-	resv
19	R	-	CPU3 Sleep status: 1 = powered down
18	R	-	CPU2 Sleep status: 1 = powered down
17	R	-	CPU1 Sleep status: 1 = powered down
16	R	-	CPU0 Sleep status: 1 = powered down
15~10	R/W	00	resv
9~8	R/W	11	CPU3 sleep: 11 = powered down
7~6	R/W	11	CPU2 sleep: 11 = powered down
5~4	R/W	11	CPU1 sleep: 11 = powered down
3~2	R/W	00	CPU0 sleep: 11 = powered down
1	R/W	1	Nic400 pwr up req
0	R/W	0	resv

**Table 7-17 AO\_RTI\_GEN\_PWR\_SLEEP0 0x3a**

Bit(s)	R/W	Default	Description
31~20	R/W	0	Resv
19	R/W	1	GE2D power off: 1 = powered off, 0 = powered on

Bit(s)	R/W	Default	Description
18	R/W	1	PCIE_COMB power off: 1 = powered off, 0 = powered on
17	R/W	1	USB_COMB power off: 1 = powered off, 0 = powered on
16	R/W	1	NNA power off: 1 = powered off, 0 = powered on
15~9	R/W	1	Resv
8	R/W	1	VPU/HDMI power off: 1 = powered off, 0 = powered on
7~4	R/W	0	Resv
3	R/W	3	Dos HEVC encoder power off: 1 = powered off, 0 = powered on
2	R/W	0	Dos hevc power off: 1 = powered off, 0 = powered on
1	R/W	3	Dos vdec power off: 1 = powered off, 0 = powered on
0	R/W	3	Dos hcodec power off: 1 = powered off, 0 = powered on

Table 7-18 AO\_RTI\_GEN\_PWR\_ISO0 0x3b

Bit(s)	R/W	Default	Description
31~20	R/W	0	Resv
19	R/W	1	GE2D isolation enable: 1 = enabled, 0 = disabled
18	R/W	1	PCIE_COMB isolation enable: 1 = enabled, 0 = disabled
17	R/W	1	USB_COMB isolation enable: 1 = enabled, 0 = disabled
16	R/W	1	NNA isolation enable: 1 = enabled, 0 = disabled
15~9	R/W	1	Resv
8	R/W	1	VPU/HDMI isolation enable: 1 = enabled, 0 = disabled
7~4	R/W	0	Resv
3	R/W	3	Dos HEVC encoder isolation enable: 1 = enabled, 0 = disabled
2	R/W	0	Dos hevc isolation enable: 1 = enabled, 0 = disabled
1	R/W	3	Dos vdec isolation enable: 1 = enabled, 0 = disabled
0	R/W	3	Dos hcodec isolation enable: 1 = enabled, 0 = disabled

Table 7-19 AO\_RTI\_GEN\_PWR\_ACK0 0x3c

Bit(s)	R/W	Default	Description
31~20	RO	0	Resv
19	RO	1	GE2D power ack: 1 = power switch done, 0 = not done
18	RO	1	PCIE_COMB power ack: 1 = power switch done, 0 = not done
17	RO	1	USB_COMB power ack: 1 = power switch done, 0 = not done
16	RO	1	NNA power ack: 1 = power switch done, 0 = not done
15~9	RO	1	Resv
8	RO	1	VPU/HDMI power ack: 1 = power switch done, 0 = not done
3	RO	3	Dos HEVC encoder power ack: 1 = enabled, 0 = disabled

Bit(s)	R/W	Default	Description
2	RO	0	Dos hevc power ack: 1 = enabled, 0 = disabled
1	RO	3	Dos vdec power ack: 1 = enabled, 0 = disabled
0	RO	3	Dos hcodec power ack: 1 = enabled, 0 = disabled

Table 7-20 AO\_RTI\_GEN\_PWR\_SYS\_CPU\_MEM\_PD0 0x3d

Bit(s)	R/W	Default	Description
31-28	R/W	0xF	CPU2 RAM power down[3:0] (Each Bit controls different RAMs): 1 = powered down
27:14	R/W	0x3FFF	CPU1 RAM power down[13:0] (Each Bit controls different RAMs): 1 = powered down
13~0	R/W	0x0	CPU0 RAM power down[13:0] (Each Bit controls different RAMs): 1 = powered down

Table 7-21 AO\_RTI\_GEN\_PWR\_SYS\_CPU\_MEM\_PD1 0x3e

Bit(s)	R/W	Default	Description
31~24	R/W	0	DSU RAM power down[7:0] (Each Bit controls different RAMs): 1 = powered down
23:10	R/W	0x3FFF	CPU3 RAM power down[13:0] (Each Bit controls different RAMs): 1 = powered down
9:0	R/W	0x3FF	CPU2 RAM power down[13:4] (Each Bit controls different RAMs): 1 = powered down

## 7.3 System Booting

### 7.3.1 Overview

This part describes the power-on mode configuration of the SoC, which include two portions: Cortex-M3 for security control and A55 for others.

### 7.3.2 Power-on Flow Chart

The following figure illustrates the SoC's power on sequence.

Figure 7-3 Power-on Flow Chart

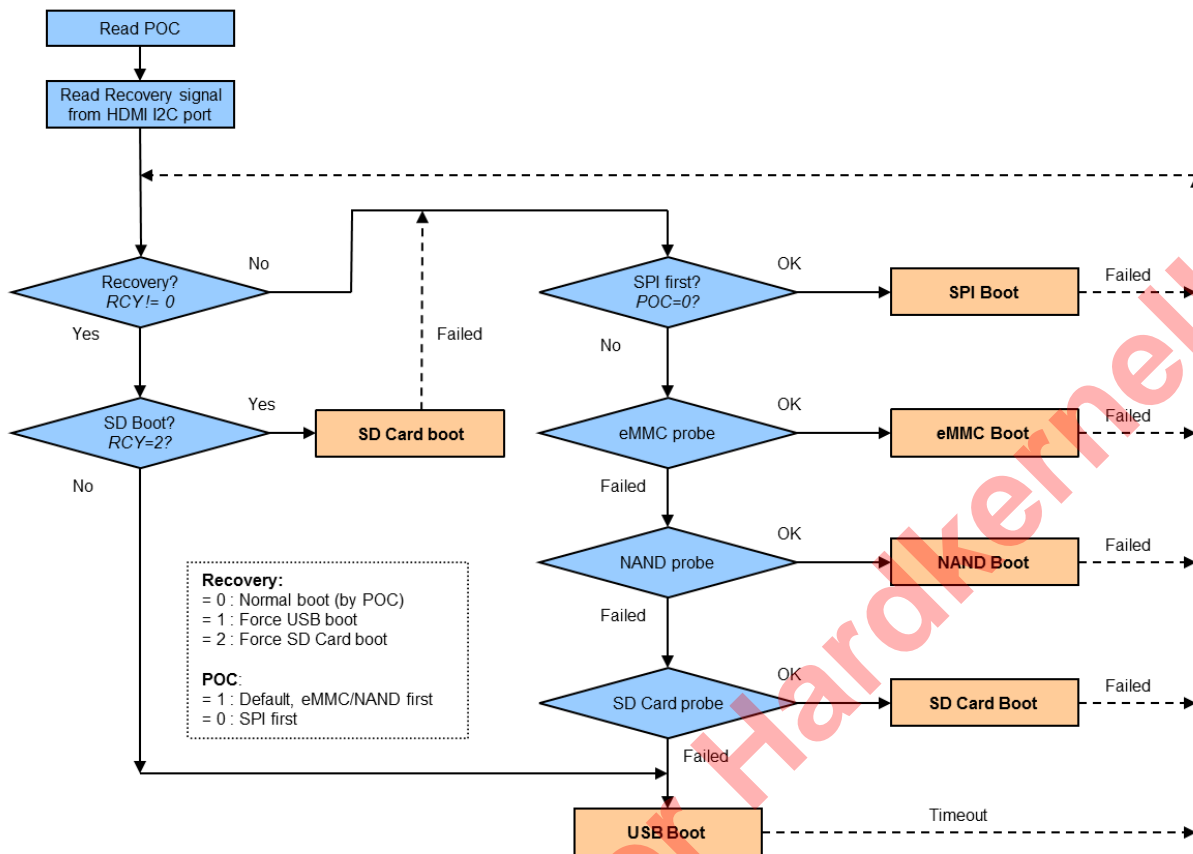

## 7.4 CPU

The Cortex™-A55 MP subsystem of the chip is a high-performance, low-power, ARM macrocell with an L1 and L3 cache subsystem that provide full virtual memory capabilities. The Cortex-A55 processor implements the ARMv8.2 architecture and runs 32-bit ARM instructions and 64 bit ARMv8 instructions. The developers can follow the ARM official reference documents for programming details.

The Cortex-A55 processor features are:

- In-order pipeline with dynamic branch prediction
- ARM, Thumb, and ThumbEE instruction set support
- TrustZone security extensions
- Harvard level 1 memory system with a Memory Management Unit (MMU)
- 128-bit AXI master interface
- ARM CoreSight debug architecture
- Trace support through an Embedded Trace Macrocell (ETMv4) interface
- Intelligent Energy Manager (IEM) support with
  - Asynchronous AXI wrappers
  - Two voltage domains
- Media Processing Engine (MPE) with NEON technology
- Supports FPU
- Supports Hardware Virtualization



## 7.5 GPU

The Mali-G31 MP2 GPU is a hardware accelerator for 2D and 3D graphics system which compatible with the following graphics standards: OpenGL ES 3.2 Vulkan 1.0 and OpenCL 2.0. The developers can follow the ARM and Khronos official reference documents for programming details.

## 7.6 NPU

### 7.6.1 Overview

NPU is the process unit which is dedicated to neural network. It is designed to accelerate the neural network arithmetic in field of AI (artificial intelligence) such as machine vision and natural language processing.

The following figure shows the hardware structure of NPU.

Figure 7-4 NPU Structure

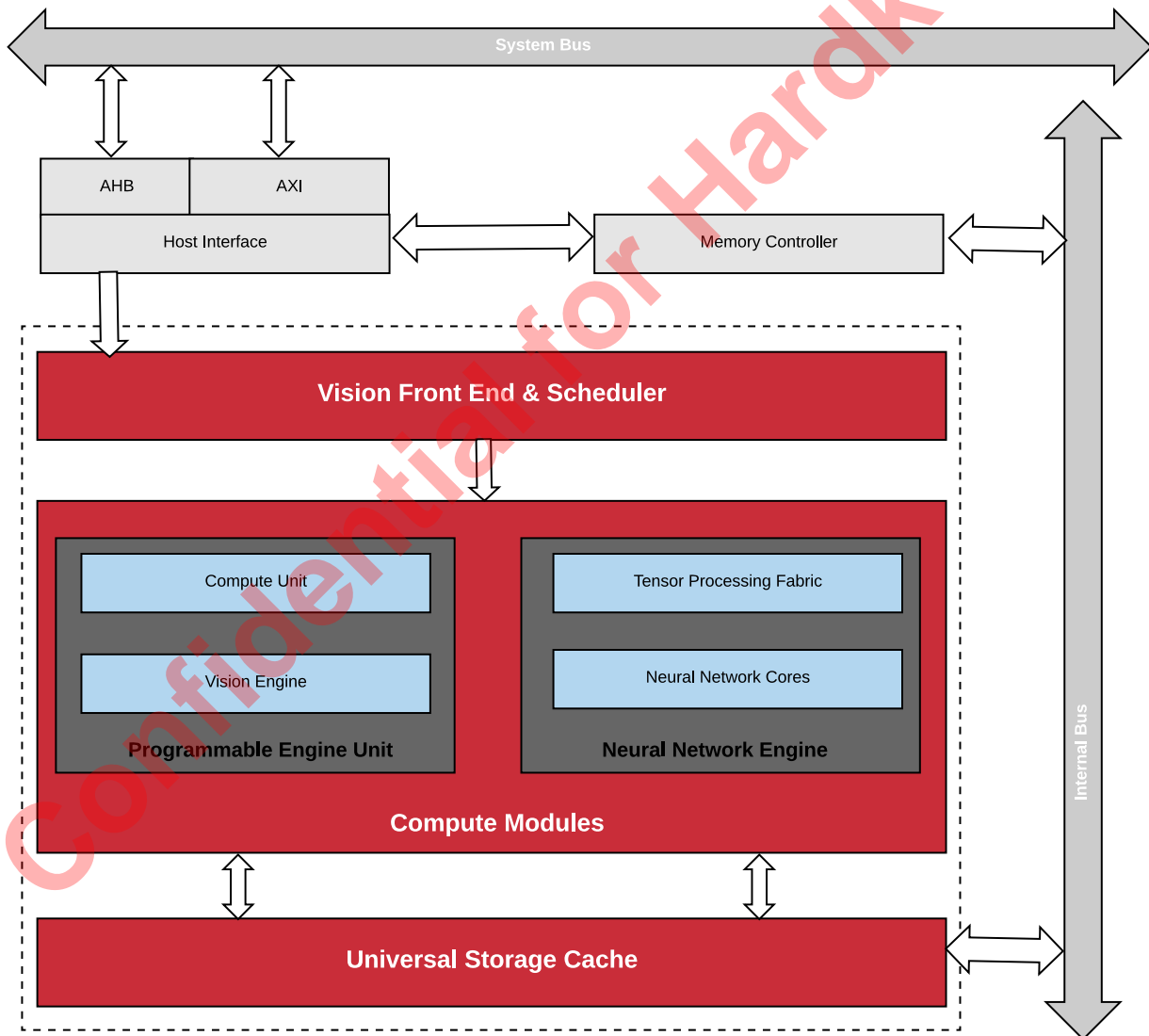

NPU supports the following features.

- **Host interface**

- 32 bit AHB interface used for configuration and only support single mode access
- 128 bit AXI interface used to fetch data memory

- **Neural Network**

- Support integer 8, integer 16 convolution operation
- 768MAC (multiply-add units) per cycle (int 8)
- 192MAC per cycle (int 16)
- Support Liner, MIMO, Fully Connected, Fully Convolution
- Unlimited network size (bound by system resource)
- Inference Engine: Tensorflow, Tensorflow lite, Darknet, Onnxc Caffe, Caffe2, Pytorch, Keras backend, OpenCL, OpenVX
- Support network sparse coefficient decompression
- Support max, average pooling
- Max pooling support 2x2, 3x3, stride  $\leq$  min (input width, input height)
- Local average pooling size  $\leq$  11x11
- Support unpooling
- Support batch normalize, l2 normalize, local response normalize, Instance normalize
- Support region proposal
- Support permute, reshape, concat, depth to space, space to depth, flatten, reorg, squeeze and split
- Support prior\_box layer
- Support non-max Suppression
- Support ROI pooling
- Convolution size NXN,  $N \leq 11 * \text{stride}$ , stride  $\leq$  min(input width, input height)
- Support dilate convolution,  $N \leq 11 * \text{stride}$ , stride  $\leq$  min(input width, input height), dilation < 1024
- Support de-convolution,  $N \leq 11 * \text{stride}$ , stride  $\leq$  min(input width, input height)
- Support Element\_wise add, div, floor, max, mul, scale, sub
- Support ReLU, Leaky ReLU, Softmax, PreLU, Sigmod, Tanh
- Support LSTM, RNN
- Support channel shuffle
- Support dequantize, dropout
- Include embedded lookup table
- Support hashtable lookup
- Support lsh projection
- Support svdf
- Support reserve

## 7.6.2 Register Description

**Table 7-22 AQHiClockControl 0x0000**

Bit(s)	R/W	Name	Description
0	R/W	CLK3D_ DIS	Disable 3D clock. Software core clock disable signal for 3D modules(clk_3d) clock. When set to 1, this clock is frozen.
1	R/W	CLK2D_ DIS	Disable 2D clock. Software clock disable signal. For this core both bits CLK3D_ DIS and CLK2D_ DIS should be controlled by software. The AXI interface clock is the only block not stalled at that point.
8:2	R/W	FSCAL- E_VAL	Core clock frequency scale value.
9	R/W	FSCAL- E_CMD_ LOAD	Core clock frequency scale value enable. When writing a 1 to this bit, it updates the frequency scale factor with the value FSCALE_VAL[6:0]. The bit must be set back to 0 after that. If this bit is set and FSCALE_VAL=0 (an invalid combination), the HREADYOUT output signal will get stuck to 0.
10	R/W	DISA- BLE_ RAM_ CLOCK_ GATING	Disables clock gating for rams.
13	R/W	DISA- BLE_ RAM_ POW- ER_OP- TIMIZA- TION	Disables ram power optimization.
16	R	IDLE3_D	3D pipe is idle.
19	R/W	ISO- LATE_ GPU	Isolate GPU bit. Used for power on/off, isolation only for multi-core GPUs.
23:20	R/W	MULTI_ PIPE_ REG_ SELECT	Determines which HI/MC to use while reading registers.

**Table 7-23 AQHIdle 0x0001**

Bit(s)	R/W	Name	Description
0	R	IDLE_FE	FE is idle.
1	R	IDLE_SH	SH is idle.
31	R	AXI_LP	AXI is in low power mode.

**Table 7-24 AQAxIStatus 0x0003**

Bit(s)	R/W	Name	Description
9	R	DET_ RD_ERR	Detect read error
8	R	DET_ WR_ ERR	Detect write error

Bit(s)	R/W	Name	Description
7:4	R	RD_ERR_ID	Read Error ID
3:0	R	WR_ERR_ID	Write Error ID

**Table 7-25 AQIntrAcknowledge 0x0004**

Bit(s)	R/W	Name	Description
31:0	R	INTR_VEC	For each interrupt event, 0=Clear, 1=InterruptActive Bit 31 is AXI_BUS_ERROR, 0 = No Error.

**Table 7-26 AQIntrEnbl 0x0005**

Bit(s)	R/W	Name	Description
31:0	R/W	INTR_ENBL_VEC	0: Disable interrupt; 1: Enable interrupt

**Table 7-27 GCChipRev 0x0009**

Bit(s)	R/W	Name	Description
31:0	R	REV	Revision

**Table 7-28 GCChipDate 0x000A**

Bit(s)	R/W	Name	Description
31:0	R	DATE	Date.

**Table 7-29 gcTotalCycles 0x001E**

Bit(s)	R/W	Name	Description
31:0	R/W	CYCLES	

**Table 7-30 gcregHIChipPatchRev 0x0026**

Bit(s)	R/W	Name	Description
7:0	R	PATCH_REV	

**Table 7-31 gcProductId 0x002A**

Bit(s)	R/W	Name	Description
3:0	R	GRADE_LEVEL	0: None-no extra letter on the product name 1:N-Nano 2:L-Lite 3:UL-UltraLite
23:4	R	NUM	Product Number

Bit(s)	R/W	Name	Description
27:24	R	TYPE	VIP (OpenVX/VIP only core)
31:28	R		this value is 0 and Convolution core count is provided in gcEcold bits 31:24.

Table 7-32 gcEcold 0x003A

Bit(s)	R/W	Name	Description
7:0	R	ID	ECO Id.
31:24	R	CONV_COUNT	For example: 0x00: No convolution cores. 0x01: 1 CC, (= .5 NN). 0x02: 2 CC, S variant (Single = 1NN). 0x03: 3 CC, S+ variant (= 1.5 NN). 0x04: 4 CC, D variant (Dual = 2NN). 0x06: 6 CC, D+ variant (= 3 NN). 0x08: 8 CC, Q variant (Quad = 4 NN). 0x10: 16 CC, O variant (Octo = 8 NN). 0x20: 32 CC, H variant (Hex = 16 NN).

Table 7-33 gcModulePowerControls 0x0040

Bit(s)	R/W	Name	Description
0	R/W	ENABLE_MODULE_CLOCK_GATING	Enables module level clock gating.
1	R/W	DISABLE_STALL_MODULE_CLOCK_GATING	Disables module level clock gating for stall condition.
2	R/W	DISABLE_STARVE_MODULE_CLOCK_GATING	Disables module level clock gating for starve/idle condition.
7:4	R/W	TURN_ON_COUNTER	Number of clock cycles to wait after turning on the clock.
31:16	R/W	TURN_OFF_COUNTER	Counter value for clock gating the module if the module is idle for this amount of clock cycles.

Table 7-34 gcregMMUAHBControl 0x00E2

Bit(s)	R/W	Name	Description
0	W	MMU	Enable the MMU. For security reasons, once the MMU is enabled it cannot be disabled anymore. writeOnce

**Table 7-35 gcregMMUAHBTableArrayBaseAddressLow 0x00E3**

Bit(s)	R/W	Name	Description
31:0	R/W	AD-DRESS	32 bit Address for MMUTableArrayBaseLow 32bit.

**Table 7-36 gcregMMUAHBTableArrayBaseAddressHigh 0x00E4**

Bit(s)	R/W	Name	Description
7:0	R/W	MAS-TER_TLB	Upper 8-bits of the master TLB address to form a true 40-bit address.
8	R/W	MAS-TER_TLB_SE-CURE	Bit that defines whether the master TLB address is secure or not
9	R/W	MAS-TER_TLB_SHARE-ABLE	Bit that defines whether the master TLB address is shareable or not.

**Table 7-37 gcregMMUAHBTableArraySize 0x00E5**

Bit(s)	R/W	Name	Description
15:0	R/W	SIZE	16 bit MMUTableArraySize.

**Table 7-38 gcregMMUAHBSafeNonSecureAddress 0x00E6**

Bit(s)	R/W	Name	Description
31:0	R/W	AD-DRESS	A 64-byte address that will acts as a 'safe' zone. Any address that would cause an exception is routed to this safe zone. Reads will happen and writes will go to this address, but with a write-enable of 0. This register can only be programmed once after a reset - any attempt to write to this register after the initial write-after-reset will be ignored. This is in NonSecure memory.

**Table 7-39 gcregMMUAHBSafeSecureAddress 0x00E7**

Bit(s)	R/W	Name	Description
31:0	R/W	AD-DRESS	Description: A 64-byte address that will act as a 'safe' zone. Any address that would cause an exception is routed to this safe zone. Reads will happen and writes will go to this address, but with a write-enable of 0. This register can only be programmed once after a reset - any attempt to write to this register after the initial write-after-reset will be ignored. This is in Secure memory.

**Table 7-40 gcregCmdBufferAHBCtrl 0x00E9**

Bit(s)	R/W	Name	Description
15:0	W	PRE-FETCH	Number of 64-bit words to fetch from the command buffer.
16	W	ENABLE	Enable the command parser. 0 => DISABLE 1 => ENABLE

**Table 7-41 gcregHiAHBControl 0x00EA**

Bit(s)	R/W	Name	Description
0	R/W	SOFT_RESET	Soft resets the IP. 1 => ENABLE 0 => DISABLE
1	R/W	DEBUG_MODE	Enable debug mode if disabled debug registers return 0xFFFF FFFF. 1 => ENABLE 0 => DISABLE

**Table 7-42 gcregAxiAHBConfig 0x00EB**

Bit(s)	R/W	Name	Description
3:0	R/W	AWID	
7:4	R/W	ARID	
11:8	R/W	AWC-CACHE	Set AWCACHE[3:0] value
15:12	R/W	ARC-CACHE	Set ARCCACHE[3:0] value
17:16	R/W	AXDOMAIN_SHARE-D	Configure AxDOMAIN value for shareable request
19:18	R/W	AXDOMAIN_NON_SHARE-D	Configure AxDOMAIN value for non-shareable request
23:20	R/W	AXC-CACHE_OVERRIDE_SHARE-D	Configure AxCACHE value for shareable request

**Table 7-43 AQMemoryDebug 0x0105**

Bit(s)	R/W	Name	Description
7:0	R/W	MAX_OUTSTANDING_READS	Limits the total number of outstanding read requests.

**Table 7-44 AQRegisterTimingControl 0x010B**

Bit(s)	R/W	Name	Description
7:0	R/W	FOR_RF1P	For 1 port RAM
15:8	R/W	FOR_RF2P	For 2 port RAM
17:16	R/W	FAST_RTC	RTC for fast RAM
19:18	R/W	FAST_WTC	WTC for fast RAM
20	R/W	POWER_DOWN	Power down memory
21	R/W	DEEP_SLEEP	Deep sleep. Bit to allow SOC to manage sleep for embedded memories.
22	R/W	LIGHT_SLEEP	Light sleep. Bit to allow SOC to manage sleep for embedded memories.

**Table 7-45 AQCmdBufferAddr 0x0195**

Bit(s)	R/W	Name	Description
30:0	W	ADDRESS	Base address for the command buffer. The address must be 64-bit aligned and it is always physical. You can write all bits (the virtual bit is legacy). This register cannot be read. To check the value of the current fetch address use AQFEdebugCurCmdAdr. This WRITE ONLY register it has no set reset value.
31	W	TYPE	0 => SYSTEM 1 => VIRTUAL_SYSTEM

**Table 7-46 AQFEdebugCurCmdAdr 0x0199**

Bit(s)	R/W	Name	Description
31:3	R	CUR_CMD_ADR	This is the command decoder address. It has no reset value. READ ONLY

## 7.7 Clock

### 7.7.1 Overview

The clock and reset unit is an APB slave module that is designed for generating all of the internal and system clocks, resets of chip. The SoC uses an external 24MHz crystal; there are 10 internal PLLs: SYS\_PLL/DDR\_PLL/GP0\_PLL/GP1\_PLL/PCIE\_PLL/HIFI\_PLL/HDMI\_PLL/MPLL (FIXPLL)/ETHPLL/USB2PLL, these PLLs generate 24 clock sources, as shown in the following table.

TYPE	OUTPUT CLOCK	MAX FREQ	INTERNAL DIV	Spread Spectrum
SYS_PLL	SYS_CLK_OUT	6G	/1 /2 /4 /8 /16 /32	yes
GP0_PLL	GP0_CLK_OUT	6G	/1 /2 /4 /8 /16 /32	yes
GP1_PLL	GP1_CLK_OUT	6G	/1 /2 /4 /8 /16 /32	yes



TYPE	OUTPUT CLOCK	MAX FREQ	INTERNAL DIV	Spread Spectrum
HIFI_PLL	HIFI_CLK_OUT	6G	/1 /2 /4 /8	yes
PCIE_PLL	PCIE_REF_CLK_N/ P	100M(fixed)		yes
ETHPHY_PLL	ETH_CLK	500M(fixed)		No
USBPHY_PLL0/1	USB_CLK0/1	480M(fixed)		No
MPLL	FCLK_DIV2_CPU	1G(fixed)		No
	FCLK_DIV3_CPU	666M(fixed)		No
	MPLL_CLK_OUT_ DIV2_GPIO	1G(fixed)		No
	MPLL_CLK_OUT_ DIV2	1G(fixed)		No
	MPLL_CLK_OUT_ DIV2p5	800M(fixed)		No
	MPLL_CLK_OUT_ DIV3	666M(fixed)		No
	MPLL_CLK_OUT_ DIV4	500M(fixed)		No
	MPLL_CLK_OUT_ DIV5	400M(fixed)		No
	MPLL_CLK_OUT_ DIV7	285.7M(fixed)		No
	MPLL_DDS_CLK0	500M	Up to /32	No
	MPLL_DDS_CLK1	500M	Up to /32	No
	MPLL_DDS_CLK2	500M	Up to /32	yes
	MPLL_DDS_CLK3	500M	Up to /32	yes
HDMI_PLL	HDMI_CLK_OUT	6G	/1/2/4/8/16	yes
	HDMI_CLK_OUT2	6G	/1/2/4/8/16/32/64	yes
DDR_PLL	DDR_CLK4X_OUT	4.8G	/4 /6 /8 /12 /16 /8 /12 /16 /24 /32	yes
	DDR_CLK_OUT	4.8G	/2 /3 /4 /6 /8	No

### 7.7.2 Clock Trees

The following figure shows the clock connections of the SoC. In this part, we will discuss A55 clock tree, AO clock tree, HDMI clock tree and EE clock tree in details.

Figure 7-5 Clock Connections

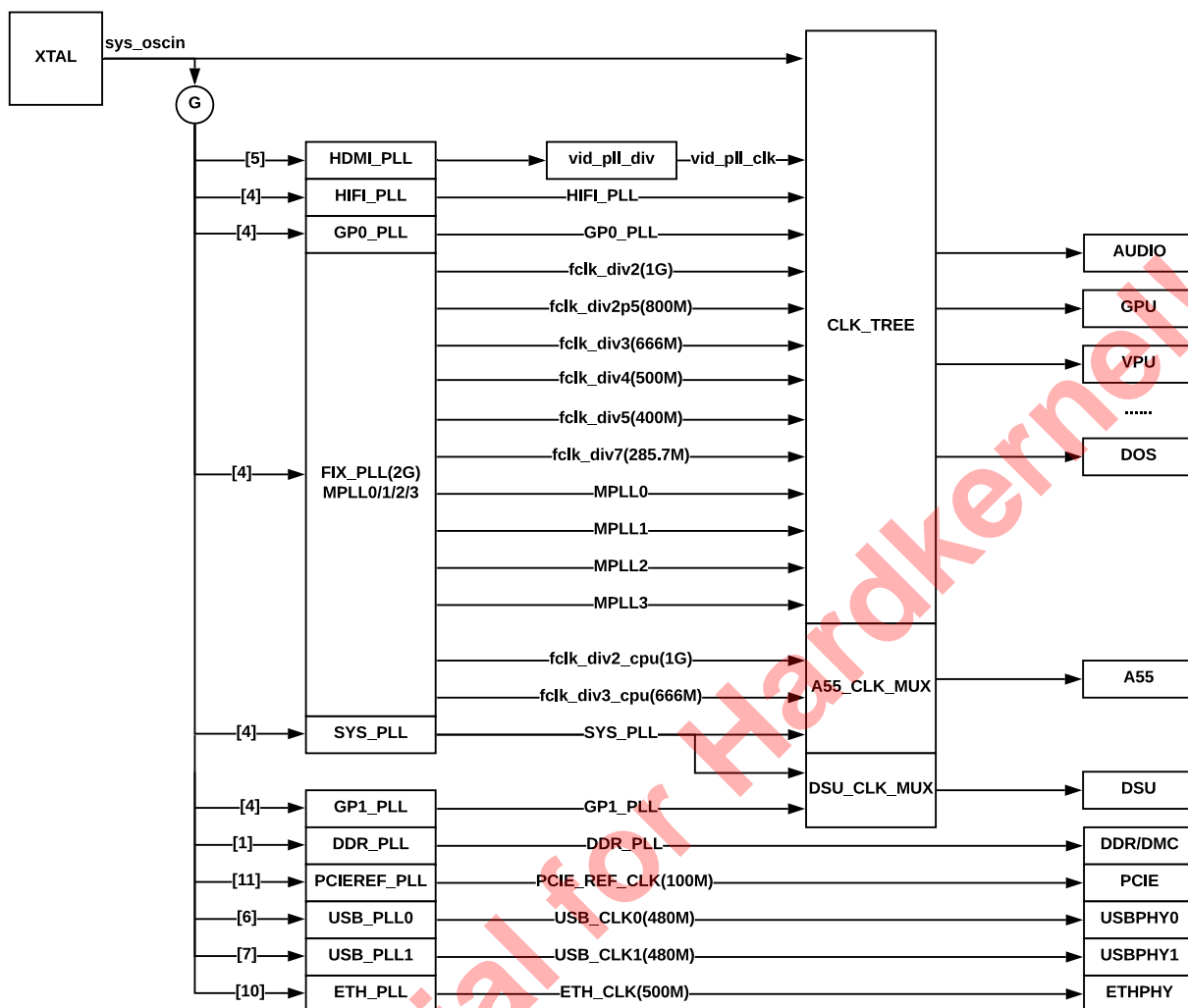

### 7.7.2.1 A55 Clock Tree

A55 has 5 clock source, as shown in the following figure, among which,

1. `cts_osc_slow_clk` is for low power and debug clock.
2. `fclk_div2` and `fclk_div3` are for frequencies lower than 1G.
3. `sys_pll` and `gp1_clk` are for frequencies higher than 1G.

Figure 7-6 Mutil Phase PLLs of A55

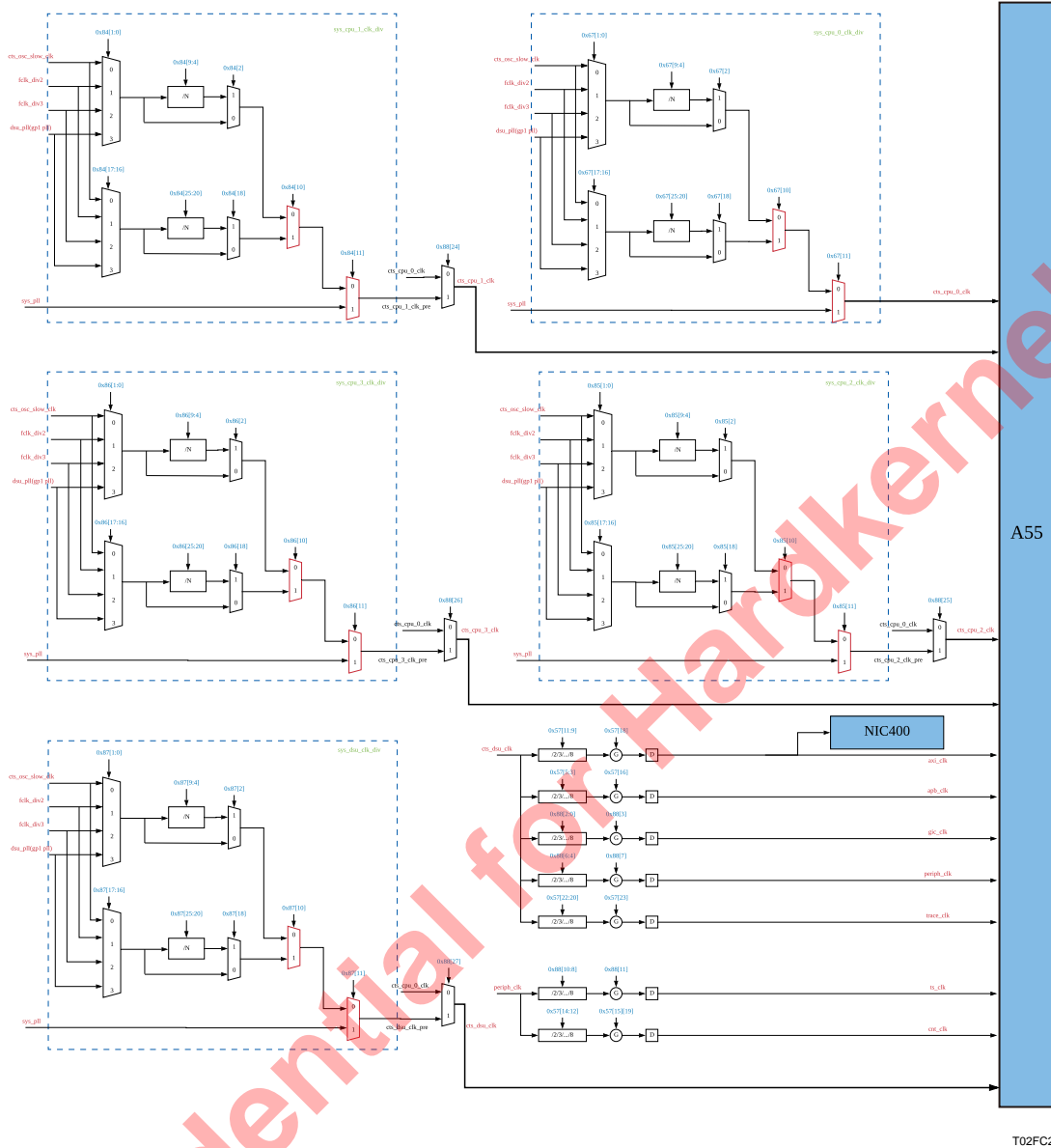

To avoid glitch when change frequencies, there are 2 specially designed dynamic muxes, labeled by red in the above figure. When frequencies changes, the dynamic muxes will first stop the first frequency, then start the second so there will be no mixing of 2 different frequencies thus generate no frequency glitch.

It is possible to do the following switch without glitch:

- Between any 2 frequencies lower than 1GHz;
- From a frequency lower than 1GHz to a frequency higher than 1GHz

If the user want to switch between 2 frequencies both higher than 1GHz, it is strongly recommended to change to frequencies lower than 1GHz first.

The diagram of specially designed dynamic mux is shown in the following diagram.

**Note**

When use these 2 dynamic muxes, both control bits of these muxes have to be configured at the same time, otherwise they will not function correctly.

**Figure 7-7 Dynamic Mux**

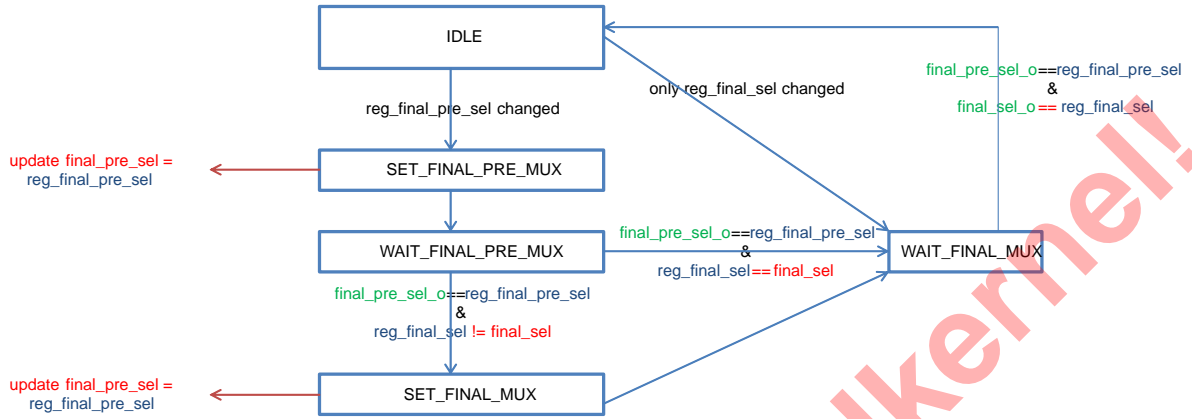

T02FC01

**7.7.2.2 AO Clock Tree**

The following figure shows the clock source of AO modules.

Figure 7-8 AO Clock Sources

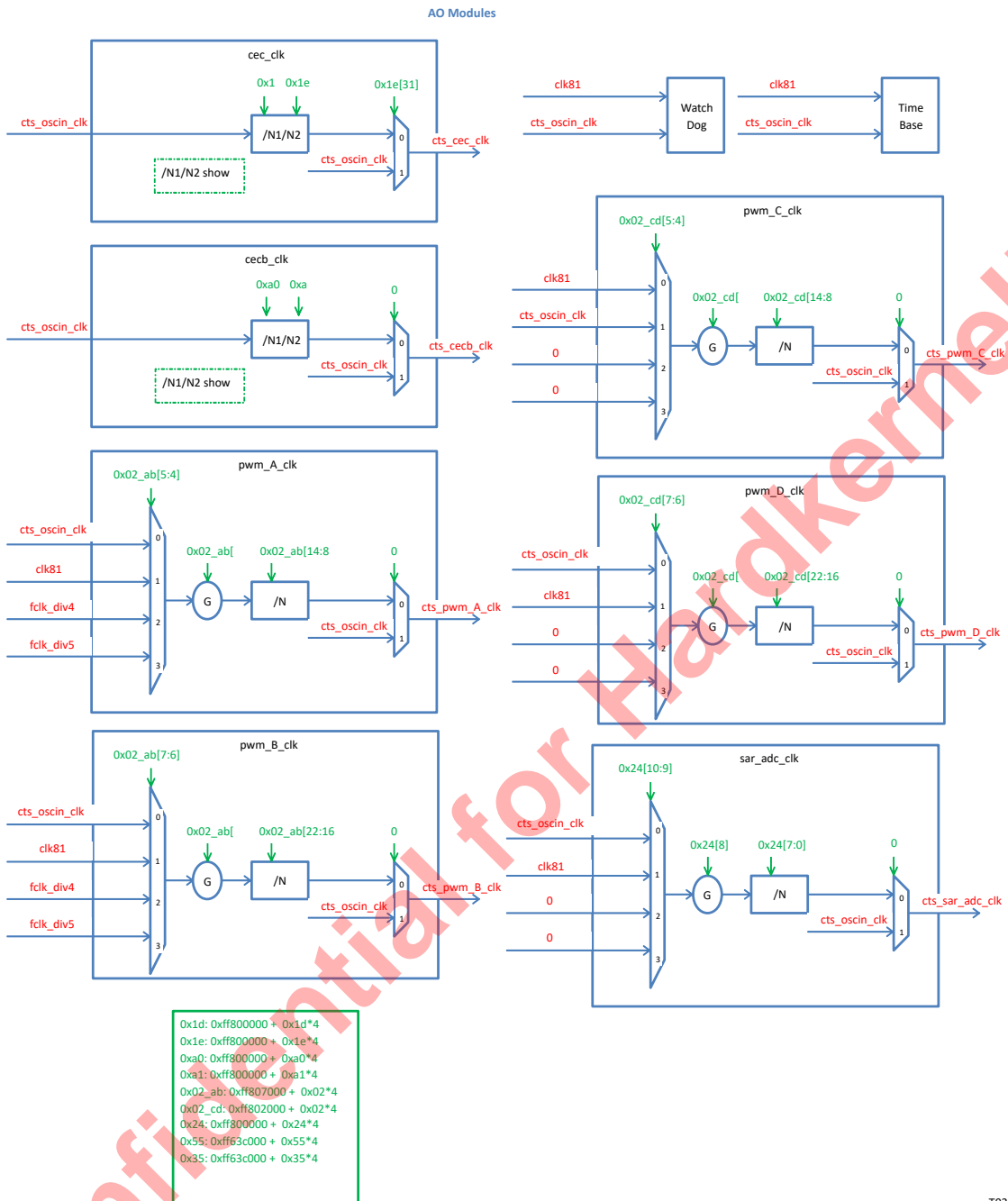

For low power mode, 32KHz clock is needed, and it is generated in AO domain as shown in the following diagram.

Figure 7-9 How to generate 32KHz Clock

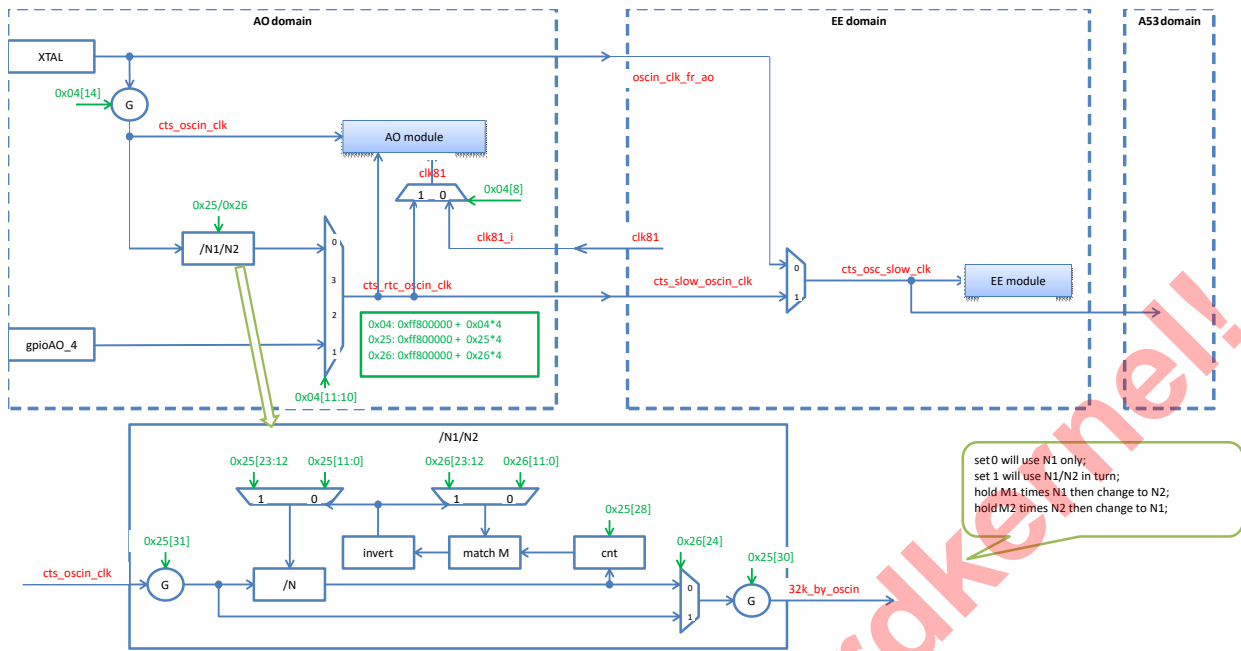

To generate the exact 32768Hz frequency, please check the following diagram.

Figure 7-10 How to generate 32786Hz Clock

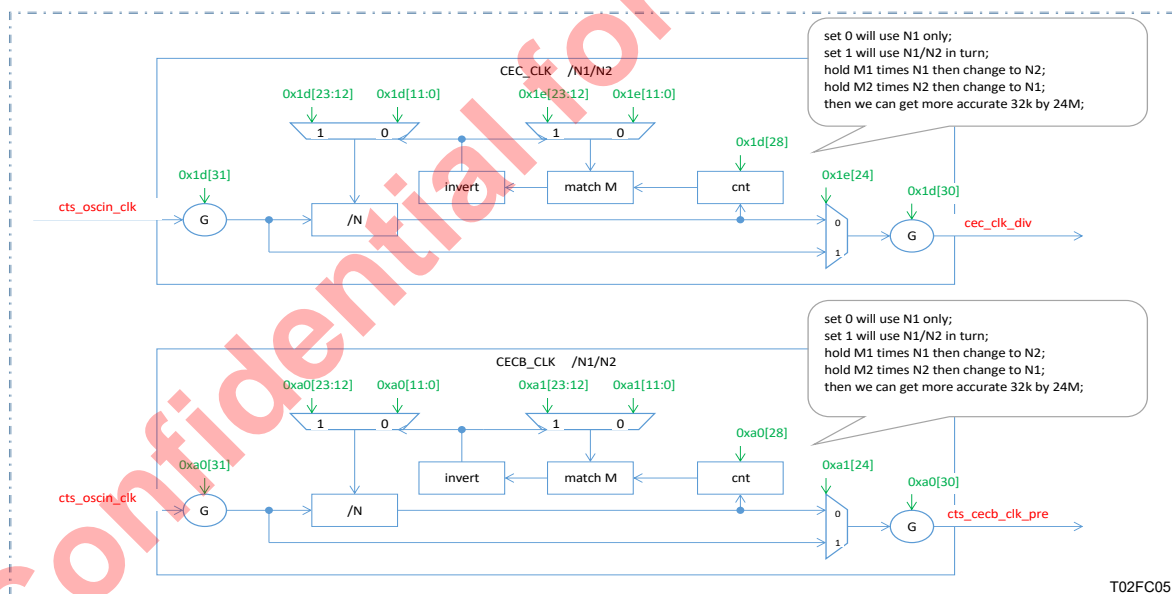

### 7.7.2.3 HDMI Clock Tree

The HDMI\_PLL goes through vid\_pll\_div to generate new clock. The HDMI clock tree is shown in the following figure.

Figure 7-11 HDMI Clock Tree

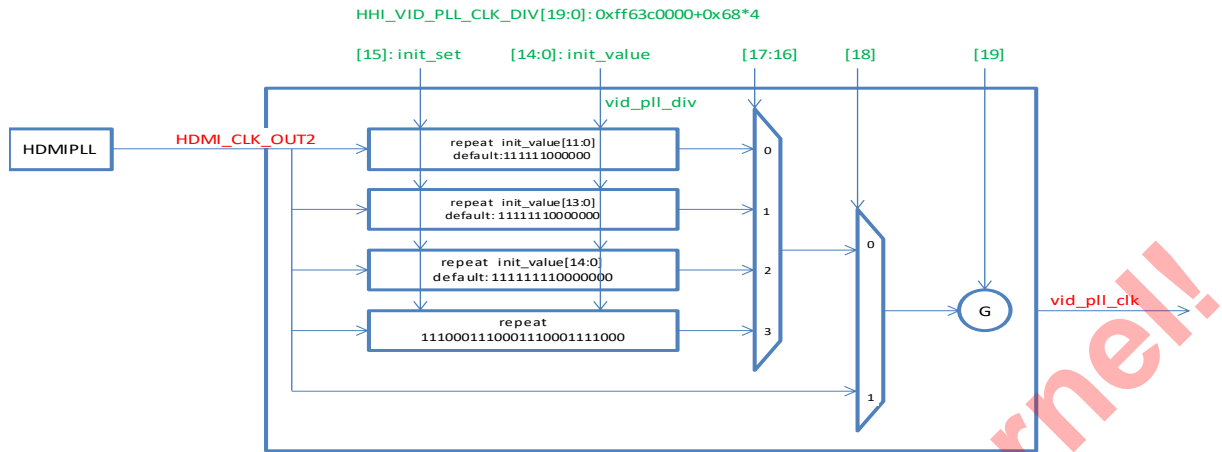

T02FC06

### 7.7.2.4 EE Clock Tree

All EE clocks except video clock are listed in the following table.

Confidential for Hardkernel!





Figure 7-13 Video Clock Tree

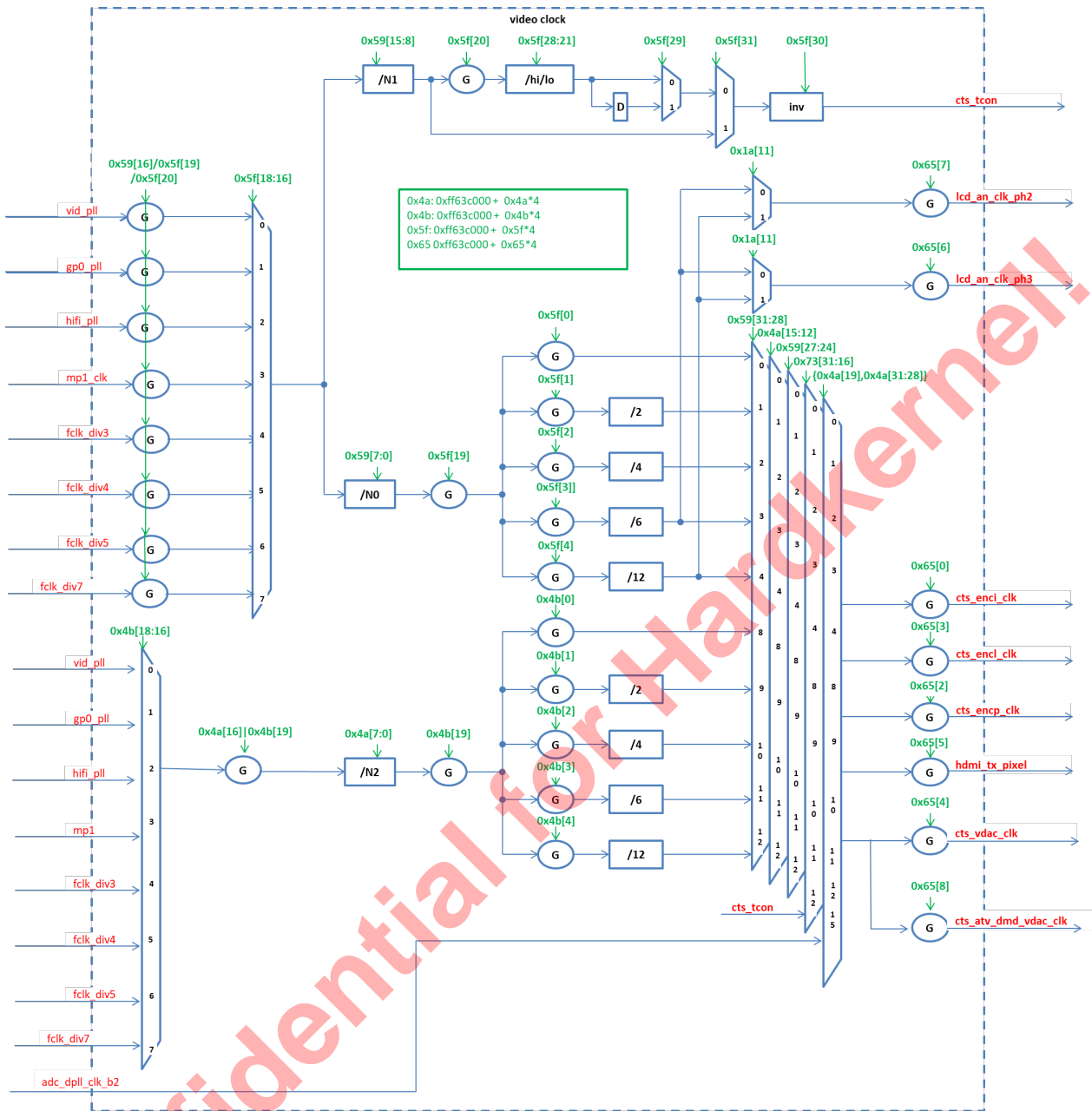

T20FC08

### 7.7.3 Frequency Calculation

#### 7.7.3.1 SYS\_PLL

SYS\_PLL diagram is shown in the following figure.

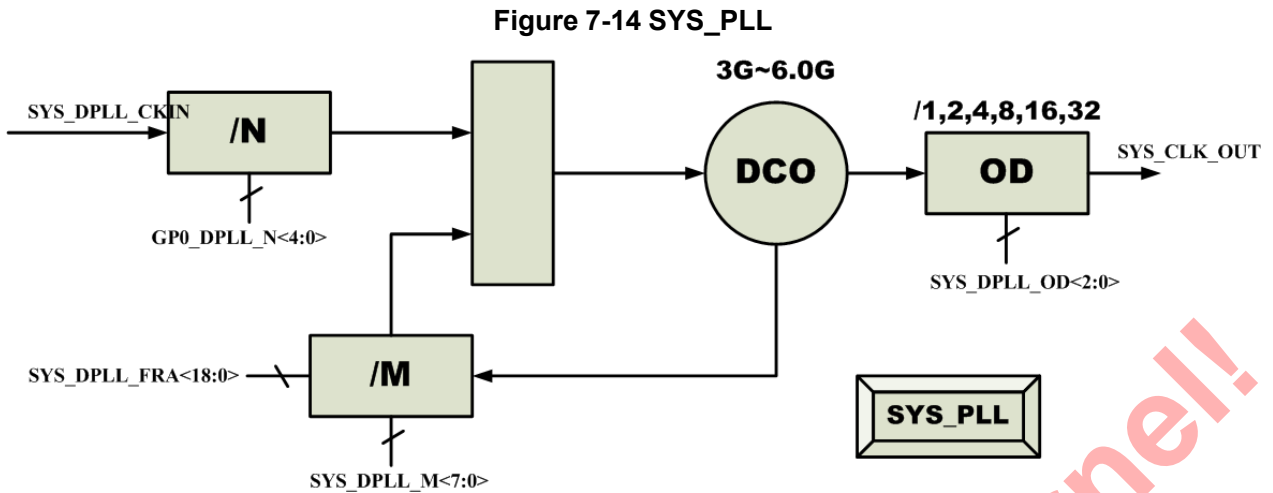

DCO frequency is calculated with the following equation:

$$f_{DCO} = f_{REF} \cdot (M + frac) / N$$

OD control table is as following.

**Table 7-47 SYS\_PLL OD Control**

Block	Register	Function
OD	SYS_DPLL_OD<2:0>	000:/1
		001:/2
		010:/4
		011:/8
		100:/16
		101:/32

### 7.7.3.2 GP0\_PLL

GP0\_PLL diagram is shown in the following figure.

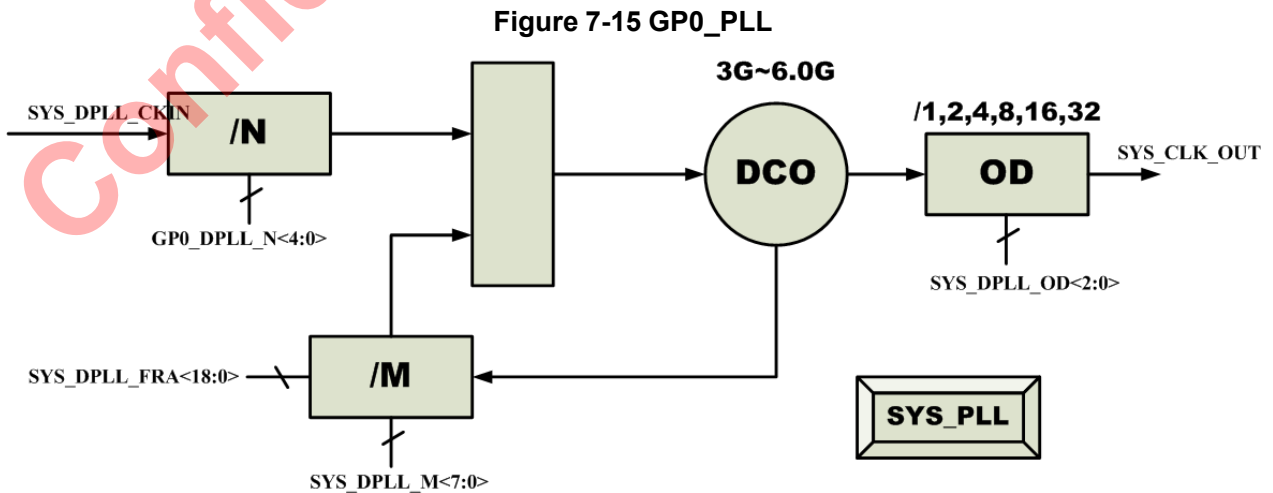

DCO frequency is calculated with the following equation:

$$f_{DCO} = f_{REF} \cdot (M + frac)/N$$

OD control table is as following.

**Table 7-48 GP0\_PLL OD Control**

Block	Register	Function
OD	GP0_DPLL_OD<2:0>	000:/1
		001:/2
		010:/4
		011:/8
		100:/16
		101:/32

### 7.7.3.3 HIFI PLL

HIFI PLL diagram is shown in the following figure.

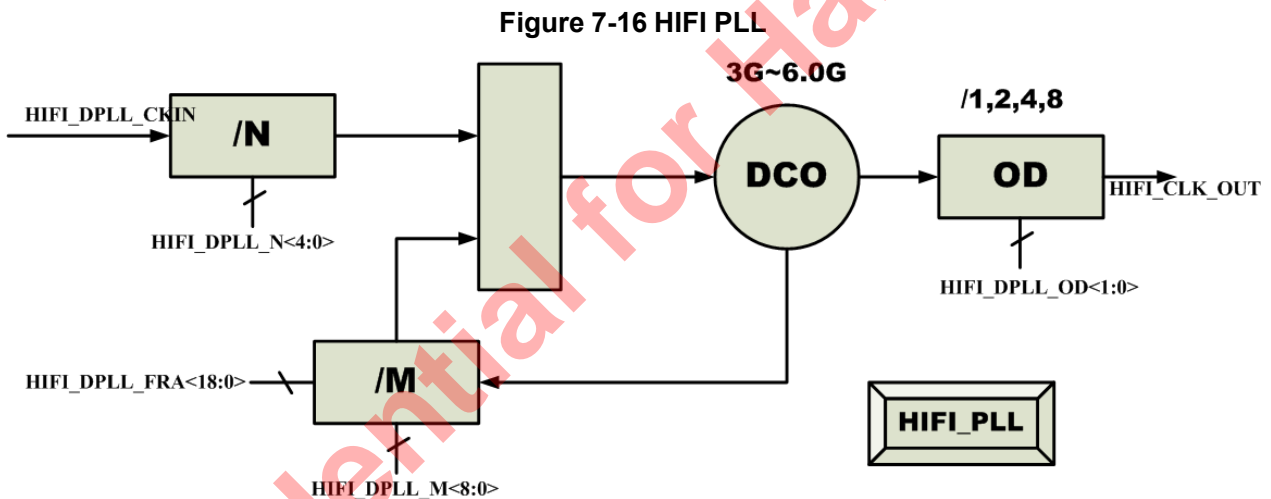

DCO frequency is calculated with the following equation:

$$f_{DCO} = f_{REF} \cdot (M + frac)/N$$

OD control table is as following.

**Table 7-49 HIFI PLL OD Control**

Block	Register	Function
OD	PCIE_DPLL_OD<1:0>	00: /1
		01:/2
		10:/4
		10:/8

### 7.7.3.4 PCIE PLL

PCIE PLL diagram is shown in the following figure.

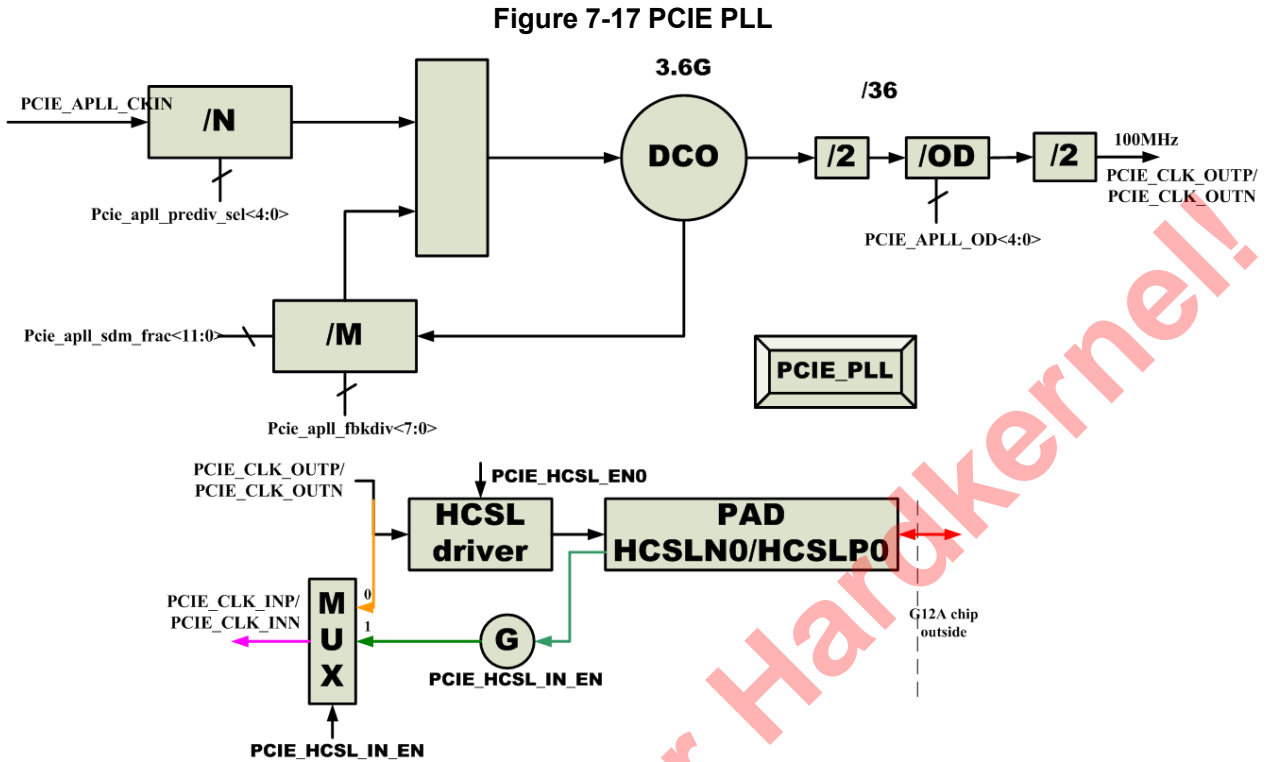

DCO frequency is calculated with the following equation:

$$f_{DCO} = f_{REF} \cdot (M + frac)/N$$

The PCIE PLL fractional value weight table is shown below.

**Table 7-50 PCIE PLL OD Control Table**

Block	Register	Function
OD	PCIE_APLL_OD<4:0>	OD<4:0>=5'h09 : 1/9

### 7.7.3.5 ETH PLL

ETH PLL diagram is shown in the following figure.

Figure 7-18 ETH PLL

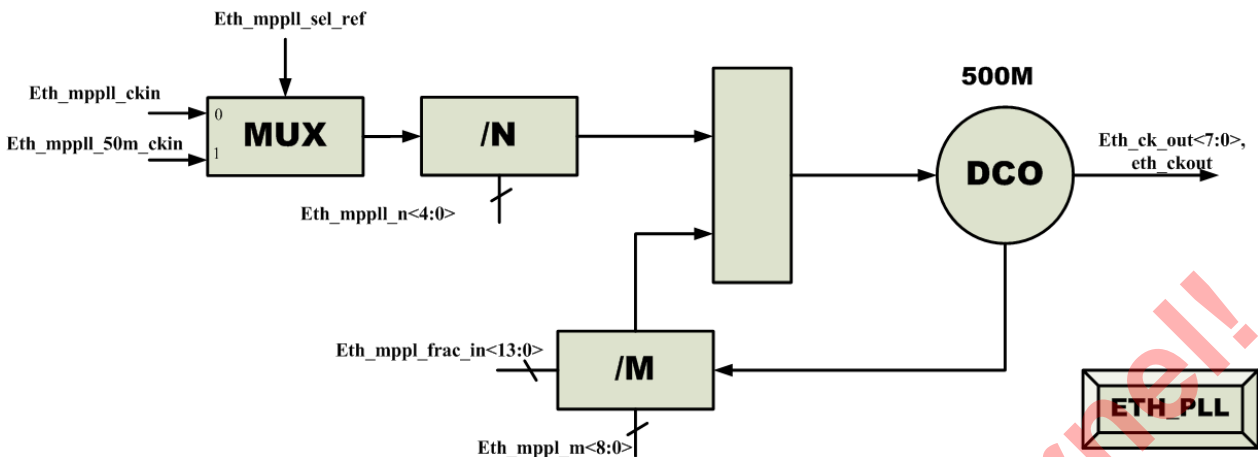

DCO frequency is 500M.

The ETH PLL fractional value weight table is shown below.

Table 7-51 ETH PLL Fractional Value Weight Table

	Bit13	Bit12	Bit11	Bit10	..	..	..	..	..	..	..	Bit0
Weight	1/2	1/2 <sup>2</sup>	1/2 <sup>3</sup>	1/2 <sup>4</sup>	..	..	..	..	..	..	..	1/2 <sup>14</sup>

### 7.7.3.6 USB PLL

USB PLL diagram is shown in the following figure.

Figure 7-19 USB PLL

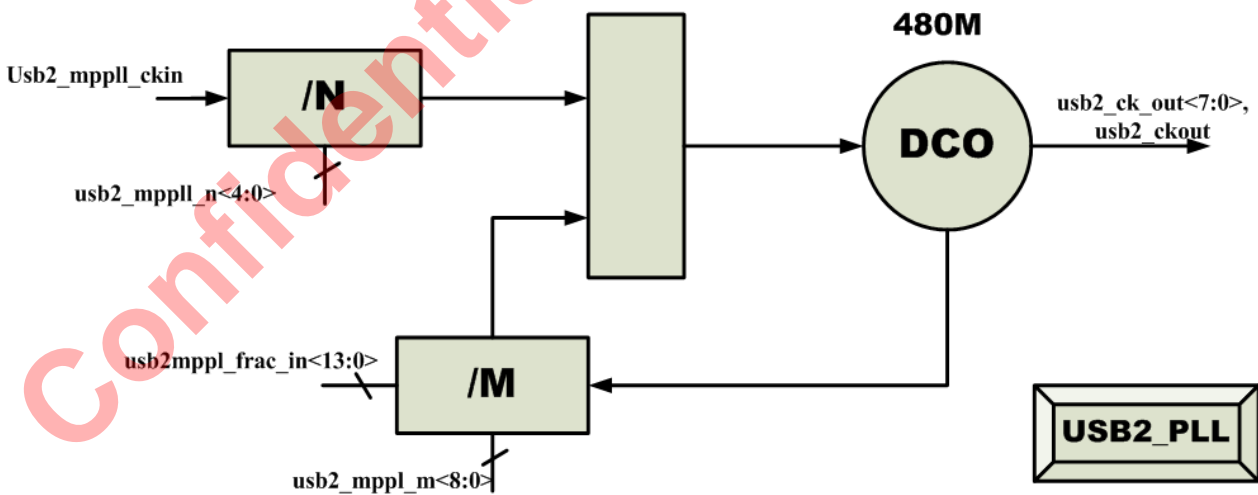

DCO frequency is 480M.

The USB PLL fractional value weight table is shown below.

**Table 7-52 USB PLL Fractional Value Weight Table**

	Bit13	Bit12	Bit11	Bit10	..	..	..	..	..	..	..	Bit0
Weight	1/2	1/2 <sup>2</sup>	1/2 <sup>3</sup>	1/2 <sup>4</sup>	..	..	..	..	..	..	..	1/2 <sup>14</sup>

### 7.7.3.7 MPLL

MPLL diagram is shown in the following figure.

**Figure 7-20 MPLL**

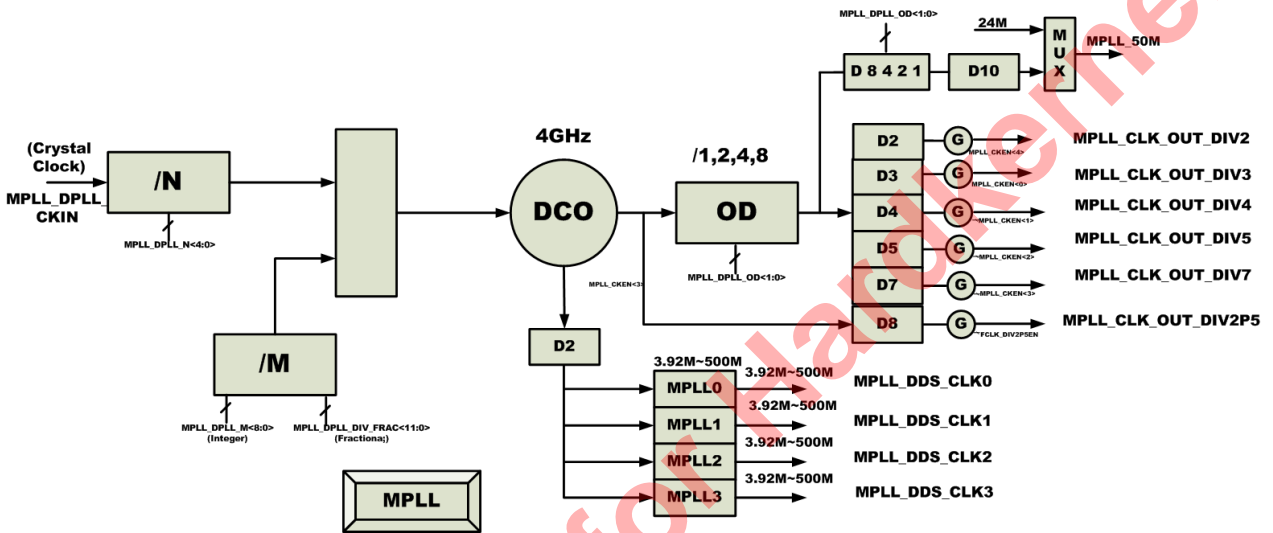

DCO frequency is calculated with the following equation:

$$f_{out\_2G} = f_{ref} * M * OD\_FB / N$$

$$MPLL\_CLK\_OUT2 = f(N2\_integer, SDM\_IN) = \left( \frac{2Ghz}{(N2\_integer + \frac{SDM\_IN}{16384})} \right)$$

### 7.7.3.8 HDMI PLL

HDMI PLL diagram is shown in the following figure.

Figure 7-21 HDMI PLL

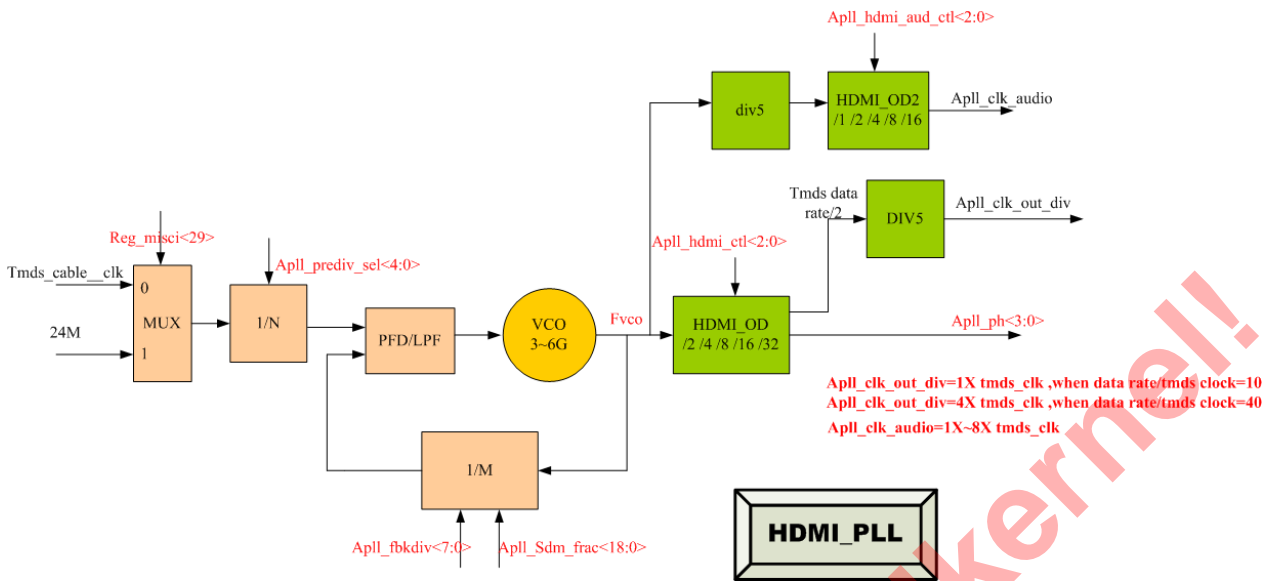

OD control table is as following.

Table 7-53 HDMI PLL OD Control

Block	Register	Function
HDMI_OD	ApIi_hdmi_ctrl<2:0>	001: /2
		010:/4
		011:/8
		100:/16
		101:/32
HDMI_OD2	ApIi_hdmi_aud_ctrl<2:0>	000: /1
		001:/2
		010:/4
		011:/8
		100:/16

### 7.7.3.9 DDR\_PLL

DDR\_PLL diagram is shown in the following figure.

Figure 7-22 DDR\_PLL

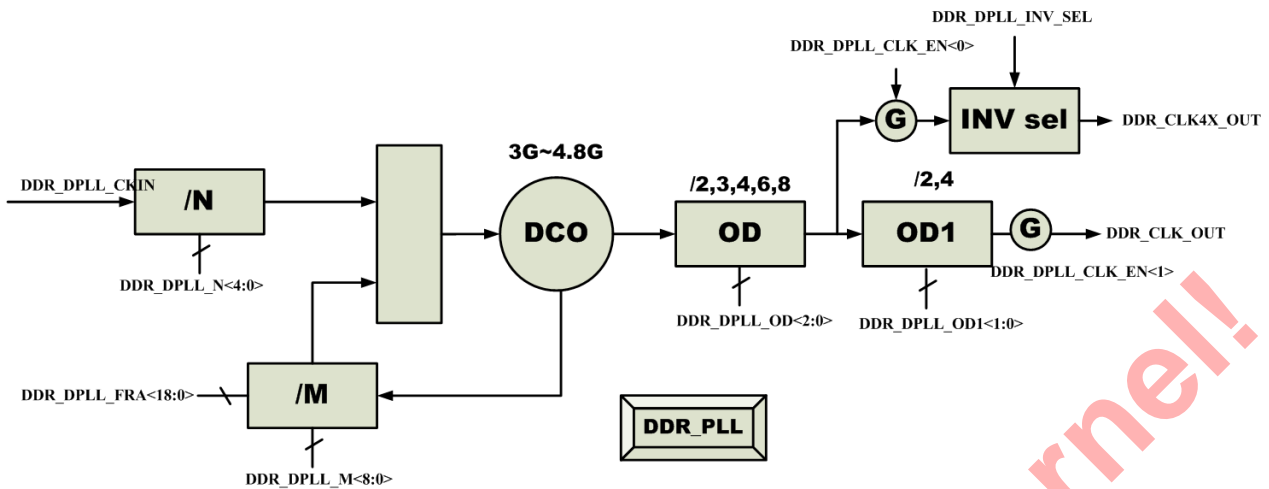

OD control table is as following.

Table 7-54 DDR\_PLL OD Control

Block	Register	Function
OD	DDR_DPLL_OD<2:0>	000:/2
		001:/3
		010:/4
		011:/6
		100:/8
OD1	DDR_DPLL_OD1<1:0>	*0:/2
		*1:/4

### 7.7.4 Clock Gating

Modules and sub-modules within the chip can be disabled by shutting off the clockR. The control for these clocks comes from six CBUS registers that collectively make up a 64-bit register that controls the MPEG\_DOMAIN and a 32-bit register that controls the OTHER\_DOMAIN. The table below indicates the Bits associated with either the MPEG\_DOMAIN and OTHER\_DOMAIN gated clock enables. The table is organized by function rather than by bit order because it makes it easier to determine how to turn on/off a particular function within the chip. If a bit is set high, the clock is enabled. If a bit is set low, the clock is turned off and the module is disabled.

Table 7-55 AO Domain Clock Gating

Address	Bit(s)	Module Description
0xff80004C	31:09	Unused
	8	SARADC
	7	IR_OUT
	6	AO_UART2
	5	PROD_I2C
	4	AO_UART2



Address	Bit(s)	Module Description
	3	AO_I2C_S0
	2	AO_I2C_M0
	1	IR_IN
	0	AHB
0xff800050	31:06	Unused
	5	M4_HCLK
	4	M4_FCLK
	3	RTI
	2	AHB_SRAM
	1	M3
	0	MAILBOX

Table 7-56 EE Domain Clock Gating (clk81)

Address	Bit(s)	Module Description
0xff63c140 0xff63c0c0	31	-
	30	spi
	29	-
	28	acodec
	27	-
	26	emmc_c
	25	emmc_b
	24	emmc_a
	23	ASSIST_MISC
	22	-
	21	-
	20	
	19	HIU Registers
	18	-
	17	-
	16	AML async fifo
	15	stream
	14	spicc_1
	13	uart0
	12	random64
11	smartcard	
10	sana	
9	i2c	

Address	Bit(s)	Module Description
	8	spicc_0
	7	PERIPHS top
	6	PL310 (AXI Matrix) to CBUS
	5	ISA module
	4	eth_phy
	3	-
	2	-
	1	u_dos_top()
	0	dmc/am2axi_arb
0xff63c144 0xff63c0c4	31	-
	30	-
	29	AHB ARB0
	28	parser1
	27	pciephy
	26	USB General
	25	parser0
	24	pciecomb
	23	RESET
	22	-
	21	-
	20	General 2D Graphics Engine
	19	nna
	18	-
	17	-
	16	uart1
	15	-
	14	-
	13	ADC
	12	-
	11	aififo
	10	-
	9	-
	8	-
	7	-
	6	-
	5	-
	4	Set top box demux module u_stb_top.clk

Address	Bit(s)	Module Description
	3	Ethernet core logic
	2	-
	1	-
	0	audio
0xff63c148 0xff63c0c8	31	-
	30	gic
	29	-
	28	-
	27	-
	26	-
	25	VPU Interrupt
	24	-
	23	-
	22	temp sensor
	21	-
	20	-
	19	-
	18	-
	17	-
	16	-
	15	uart2
	14	-
	13	-
	12	-
	11	MMC PCLK
	10	-
	9	-
	8	USB1 to DDR bridge
	7	-
	6	bt656
	5	-
4	hdmitx_top hdmitx_pclk	
3	hdmitx_top htx_hdcp22_pclk	
2	AHB control bus	
1	AHB data bus	
0	-	
0xff63c150 0xff63c0cc	31	-
	30	-

Address	Bit(s)	Module Description
	29	-
	28	-
	27	-
	26	VCLK2_OTHER
	25	VCLK2_VENCL
	24	VCLK2_VENCL
	23	VCLK2_ENCL
	22	VCLK2_ENCT
	21	Random Number Generator
	20	ENC480P
	19	-
	18	-
	17	-
	16	IEC958_GATE
	15	-
	14	AOCLK_GATE
	13	-
	12	-
	11	-
	10	DAC_CLK
	9	VCLK2_ENCP
	8	VCLK2_ENCI
	7	VCLK2_OTHER
	6	VCLK2_VENCT
	5	VCLK2_VENCT
	4	VCLK2_VENCP
	3	VCLK2_VENCP
	2	VCLK2_VENCI
	1	VCLK2_VENCI
	0	-
0xff63c154	31:5	-
	4	sec_ahb_apb3
	3	reset_sec
	2	rom_boot
	1	efuse
	0	dma

### 7.7.5 Clock Measure

The chip contains a module that can measure the frequency of internal clock. The frequency measurement is a simple counter measurement in which the counter (driven by MCLK) is enabled for a programmable amount of time. The sources are listed in the following table.

**Table 7-57 Clock Measure Source**

No.	Source
127	-
126	-
125	-
124	-
123	audio_resampleb_clk
122	mod_audio_pdm_dclk_o
121	audio_spdifin_mst_clk
120	audio_spdifout_mst_clk
119	audio_spdifout_b_mst_clk
118	audio_pdm_sysclk
117	audio_resampleA_clk
116	audio_tdm_in_a_sclk
115	audio_tdm_in_b_sclk
114	audio_tdm_in_c_sclk
113	audio_tdm_in_lb_sclk
112	audio_tdm_out_a_sclk
111	audio_tdm_out_b_sclk
110	audio_tdm_out_c_sclk
109	c_alocker_out_clk
108	c_alocker_in_clk
107	au_dac_clk_g128x
106	ephy_test_clk
105	am_ring_osc_clk_out[16]
104	am_ring_osc_clk_out[15]
103	am_ring_osc_clk_out[14]
102	am_ring_osc_clk_out[13]
101	am_ring_osc_clk_out[12]
100	am_ring_osc_clk_out[11]
99	am_ring_osc_clk_out[10]
98	cts_ts_clk
97	cts_vpu_clkb_tmp

No.	Source
96	cts_vpu_clkb
95	eth_phy_plltxclk
94	eth_phy_rxclk
93	vad_clk
92	nna_axi_clk
91	nna_core_clk
90	cts_hdmitx_sys_clk
89	HDMI_CLK_TODIG
88	-
87	-
86	am_ring_osc_clk_out[9]
85	am_ring_osc_clk_out[8]
84	co_tx_clk
83	co_rx_clk
82	cts_ge2d_clk
81	cts_vapbclk
80	rng_ring_osc_clk[3]
79	rng_ring_osc_clk[2]
78	rng_ring_osc_clk[1]
77	rng_ring_osc_clk[0]
76	am_ring_osc_clk_out[7]
75	cts_hevcf_clk
74	am_ring_osc_clk_out[6]
73	cts_pwm_C_clk
72	cts_pwm_D_clk
71	cts_pwm_E_clk
70	cts_pwm_F_clk
69	cts_hdcp22_skpclk
68	cts_hdcp22_esmclk
67	cts_dsi_phy_clk
66	cts_vid_lock_clk
65	cts_spicc_0_clk
64	cts_spicc_1_clk
63	cts_dsi_meas_clk
62	cts_hevcb_clk

No.	Source
61	gpio_clk_msr
60	am_ring_osc_clk_out[5]
59	cts_hcodec_clk
58	cts_HEVC Encoder_bclk
57	cts_HEVC Encoder_cclk
56	cts_HEVC Encoder_ack
55	vid_pll_div_clk_out
54	cts_vpu_clkc
53	cts_sd_emmc_clk_A
52	cts_sd_emmc_clk_B
51	cts_sd_emmc_clk_C
50	mp3_clk_out
49	mp2_clk_out
48	mp1_clk_out
47	ddr_dpll_pt_clk
46	cts_vpu_clk
45	cts_pwm_A_clk
44	cts_pwm_B_clk
43	fclk_div5
42	mp0_clk_out
41	mac_eth_rx_clk_rmii
40	am_ring_osc_clk_out[4]
39	cts_bt656_clk0
38	cts_vdin_meas_clk
37	cts_cdac_clk_c
36	cts_hdmi_tx_pixel_clk
35	cts_mali_clk
34	eth_mppll_50m_ckout
33	-
32	mpll_clk_test_out
31	pcie_clk_inn
30	pcie_clk_inp
29	cts_sar_adc_clk
28	co_clk_in_to_mac
27	sc_clk_int

No.	Source
26	cts_eth_clk_rmii
25	cts_eth_clk125Mhz
24	mppll_clk_50m
23	mac_eth_phy_ref_clk
22	lcd_an_clk_ph3
21	rtc_osc_clk_out
20	lcd_an_clk_ph2
19	sys_cpu_clk_div16
18	sys_pll_div16
17	cts_FEC_CLK_2
16	cts_FEC_CLK_1
15	cts_FEC_CLK_0
14	mod_tcon_clk
13	hifi_pll_clk
12	mac_eth_tx_clk
11	cts_vdac_clk
10	cts_encl_clk
9	cts_encp_clk
8	clk81
7	cts_enci_clk
6	gp1_pll_clk
5	gp0_pll_clk
4	am_ring_osc_clk_out[3]
3	am_ring_osc_clk_out[2]
2	am_ring_osc_clk_out[1]
1	am_ring_osc_clk_out[0]
0	am_ring_osc_clk_out_ee[0]

### 7.7.6 Register Description

HIU(base:32'hFF63C000)

Each register final address = BASE + address \* 4



**Table 7-58 HHI\_CHECK\_CLK\_RESULT 0x04**

Bit(s)	R/W	Default	Description
31	R	0	sys_cpu core0_clk check_result
30	R	0	sys_cpu core1_clk check_result
29	R	0	sys_cpu core2_clk check_result
28	R	0	sys_cpu core3_clk check_result
27	R	0	sys_cpu dsu_clk check_result
2	R	0	encp_check_result
1	R	0	hevcb_clk_check_result
0	R	0	mali_clk_check_result

**Table 7-59 SCR System Clock Reference 0x0B**

Bit(s)	R/W	Default	Description
31-0	R/W	0	System clock reference high: bits 31:16

**Table 7-60 TIMEOUT\_VALUE: Program timer 0x0F**

Bit(s)	R/W	Default	Description
15-12	R	0	Unused
11-0	R/W	0	Program timer

Increased by 1 every 900 cycles. Triggers timer interrupt to CPU when it expires.

**Table 7-61 HHI\_GP0\_PLL\_CNTL0 0x10**

Bit(s)	R/W	Default	Description
[31]	R	0	gp0_dpll_lock
[30]	R	0	gp0_dpll_lock_a
[29]	R/W	1	gp0_dpll_reset
[28]	R/W	0	gp0_dpll_en
[18:16]	R/W	0	gp0_dpll_od
[14:10]	R/W	0	gp0_dpll_N
[7:0]	R/W	0	gp0_dpll_M

**Table 7-62 HHI\_GP0\_PLL\_CNTL1 0x11**

Bit(s)	R/W	Default	Description
[18:0]	R/W	0	gp0_dpll_frac

Table 7-63 HHI\_GP0\_PLL\_CNTL2 0x12

Bit(s)	R/W	Default	Description
[22:20]	R/W	0	gp0_dpll_fref_sel
[17:16]	R/W	0	gp0_dpll_os_ssc
[15:12]	R/W	0	gp0_dpll_ssc_str_m
[8]	R/W	0	gp0_dpll_ssc_en
[7:4]	R/W	0	gp0_dpll_ssc_dep_sel
[1:0]	R/W	0	gp0_dpll_ss_mode

Table 7-64 HHI\_GP0\_PLL\_CNTL3 0x13

Bit(s)	R/W	Default	Description
31	R/W	0	gp0_dpll_afc_bypass
30	R/W	0	gp0_dpll_afc_clk_sel
29	R/W	0	gp0_dpll_code_new
28	R/W	0	gp0_dpll_dco_m_en
27	R/W	0	gp0_dpll_dco_sdm_en
25	R/W	0	gp0_dpll_div_mode
24	R/W	0	gp0_dpll_fast_lock
23	R/W	0	gp0_dpll_fb_pre_div
22	R/W	0	gp0_dpll_filter_mode
21	R/W	0	gp0_dpll_fix_en
20	R/W	0	gp0_dpll_freq_shift_en
19	R/W	0	gp0_dpll_load
18	R/W	0	gp0_dpll_load_en
17	R/W	0	gp0_dpll_lock_f
16	R/W	0	gp0_dpll_pulse_width_en
15	R/W	0	gp0_dpll_sdmnc_en
14	R/W	0	gp0_dpll_sdmnc_mode
13	R/W	0	gp0_dpll_sdmnc_range
12	R/W	0	gp0_dpll_tdc_en
11	R/W	0	gp0_dpll_tdc_mode_sel
10	R/W	0	gp0_dpll_wait_en

Table 7-65 HHI\_GP0\_PLL\_CNTL4 0x14

Bit(s)	R/W	Default	Description
[30:28]	R/W	0	gp0_dpll_alpha
[26:24]	R/W	0	gp0_dpll_rou
[22:20]	R/W	0	gp0_dpll_lambda1
[18:16]	R/W	0	gp0_dpll_lambda0
[13:12]	R/W	0	gp0_dpll_acq_gain
[11:8]	R/W	0	gp0_dpll_filter_pvt2
[7:4]	R/W	0	gp0_dpll_filter_pvt1
[1:0]	R/W	0	gp0_dpll_pfd_gain

Table 7-66 HHI\_GP0\_PLL\_CNTL5 0x15

Bit(s)	R/W	Default	Description
[30:28]	R/W	0	gp0_dpll_adj_vco_ldo
[27:24]	R/W	0	gp0_dpll_lm_w
[21:16]	R/W	0	gp0_dpll_lm_s
[15:0]	R/W	0	gp0_dpll_reve

Table 7-67 HHI\_GP0\_PLL\_CNTL6 0x16

Bit(s)	R/W	Default	Description
[31:30]	R/W	0	gp0_dpll_afc_hold_t
[29:28]	R/W	0	gp0_dpll_lkw_sel
[27:26]	R/W	0	gp0_dpll_dco_sdm_clk_sel
[25:24]	R/W	0	gp0_dpll_afc_in
[23:22]	R/W	0	gp0_dpll_afc_nt
[21:20]	R/W	0	gp0_dpll_vc_in
[19:18]	R/W	0	gp0_dpll_lock_long
[17:16]	R/W	0	gp0_dpll_freq_shift_v
[14:12]	R/W	0	gp0_dpll_data_sel
[10:8]	R/W	0	gp0_dpll_sdmnc_ulms
[6:0]	R/W	0	gp0_dpll_sdmnc_power

Table 7-68 HHI\_GP0\_PLL\_STS 0x17

Bit(s)	R/W	Default	Description
[31]	R	0	gp0_dpll_lock
[30]	R	0	gp0_dpll_lock_a

Bit(s)	R/W	Default	Description
[29]	R	0	gp0_dpll_afc_done
[22:16]	R	0	gp0_dpll_sdmnc_monitor
[9:0]	R	0	gp0_dpll_out_rsv

Table 7-69 HHI\_GP1\_PLL\_CNTL0 0x18

Bit(s)	R/W	Default	Description
[31]	R	0	gp1_dpll_lock
[30]	R	0	gp1_dpll_lock_a
[29]	R/W	1	gp1_dpll_reset
[28]	R/W	0	gp1_dpll_en
[18:16]	R/W	0	gp1_dpll_od
[14:10]	R/W	0	gp1_dpll_N
[7:0]	R/W	0	gp1_dpll_M

Table 7-70 HHI\_GP1\_PLL\_CNTL1 0x19

Bit(s)	R/W	Default	Description
[18:0]	R/W	0	gp1_dpll_frac

Table 7-71 HHI\_GP1\_PLL\_CNTL2 0x1a

Bit(s)	R/W	Default	Description
[22:20]	R/W	0	gp1_dpll_fref_sel
[17:16]	R/W	0	gp1_dpll_os_ssc
[15:12]	R/W	0	gp1_dpll_ssc_str_m
[8]	R/W	0	gp1_dpll_ssc_en
[7:4]	R/W	0	gp1_dpll_ssc_dep_sel
[1:0]	R/W	0	gp1_dpll_ss_mode

Table 7-72 HHI\_GP1\_PLL\_CNTL3 0x1b

Bit(s)	R/W	Default	Description
31	R/W	0	gp1_dpll_afc_bypass
30	R/W	0	gp1_dpll_afc_clk_sel
29	R/W	0	gp1_dpll_code_new
28	R/W	0	gp1_dpll_dco_m_en
27	R/W	0	gp1_dpll_dco_sdm_en
25	R/W	0	gp1_dpll_div_mode

Bit(s)	R/W	Default	Description
24	R/W	0	gp1_dpll_fast_lock
23	R/W	0	gp1_dpll_fb_pre_div
22	R/W	0	gp1_dpll_filter_mode
21	R/W	0	gp1_dpll_fix_en
20	R/W	0	gp1_dpll_freq_shift_en
19	R/W	0	gp1_dpll_load
18	R/W	0	gp1_dpll_load_en
17	R/W	0	gp1_dpll_lock_f
16	R/W	0	gp1_dpll_pulse_width_en
15	R/W	0	gp1_dpll_sdmnc_en
14	R/W	0	gp1_dpll_sdmnc_mode
13	R/W	0	gp1_dpll_sdmnc_range
12	R/W	0	gp1_dpll_tdc_en
11	R/W	0	gp1_dpll_tdc_mode_sel
10	R/W	0	gp1_dpll_wait_en

Table 7-73 HHI\_GP1\_PLL\_CNTL4 0x1c

Bit(s)	R/W	Default	Description
[30:28]	R/W	0	gp1_dpll_alpha
[26:24]	R/W	0	gp1_dpll_rou
[22:20]	R/W	0	gp1_dpll_lambda1
[18:16]	R/W	0	gp1_dpll_lambda0
[13:12]	R/W	0	gp1_dpll_acq_gain
[11:8]	R/W	0	gp1_dpll_filter_pvt2
[7:4]	R/W	0	gp1_dpll_filter_pvt1
[1:0]	R/W	0	gp1_dpll_pfd_gain

Table 7-74 HHI\_GP1\_PLL\_CNTL5 0x1d

Bit(s)	R/W	Default	Description
[30:28]	R/W	0	gp1_dpll_adj_vco_ldo
[27:24]	R/W	0	gp1_dpll_lm_w
[21:16]	R/W	0	gp1_dpll_lm_s
[15:0]	R/W	0	gp1_dpll_reve

Table 7-75 HHI\_GP1\_PLL\_CNTL6 0x1e

Bit(s)	R/W	Default	Description
[31:30]	R/W	0	gp1_dpll_afc_hold_t
[29:28]	R/W	0	gp1_dpll_lkw_sel
[27:26]	R/W	0	gp1_dpll_dco_sdm_clk_sel
[25:24]	R/W	0	gp1_dpll_afc_in
[23:22]	R/W	0	gp1_dpll_afc_nt
[21:20]	R/W	0	gp1_dpll_vc_in
[19:18]	R/W	0	gp1_dpll_lock_long
[17:16]	R/W	0	gp1_dpll_freq_shift_v
[14:12]	R/W	0	gp1_dpll_data_sel
[10:8]	R/W	0	gp1_dpll_sdmnc_ulms
[6:0]	R/W	0	gp1_dpll_sdmnc_power

Table 7-76 HHI\_GP1\_PLL\_STS 0x1f

Bit(s)	R/W	Default	Description
[31]	R	0	gp1_dpll_lock
[30]	R	0	gp1_dpll_lock_a
[29]	R	0	gp1_dpll_afc_done
[22:16]	R	0	gp1_dpll_sdmnc_monitor
[9:0]	R	0	gp1_dpll_out_rsv

Table 7-77 HHI\_PCIE\_PLL\_CNTL0 0x26

Bit(s)	R/W	Default	Description
[31]	R	0	pcie_apll_lock
[30]	R	0	pcie_hcsl_cal_done
[29]	R/W	0	pcie_apll_reset
[28]	R/W	0	pcie_apll_en
[27]	R/W	0	pcie_apll_vco_div_sel
[26]	R/W	0	pcie_apll_afc_start
[20:16]	R/W	0	pcie_apll_od
[14:10]	R/W	0	pcie_apll_prediv_sel
[7:0]	R/W	0	pcie_apll_fbdiv

**Table 7-78 HHI\_PCIE\_PLL\_CNTL1 0x27**

Bit(s)	R/W	Default	Description
12	R/W	0	pcie_apll_sdm_en
[11:0]	R/W	0	pcie_apll_sdm_frac

**Table 7-79 HHI\_PCIE\_PLL\_CNTL2 0x28**

Bit(s)	R/W	Default	Description
[31:28]	R/W	0	pcie_apll_ssc_dep_sel
[25:24]	R/W	0	pcie_apll_ssc_fref_sel
[23:22]	R/W	0	pcie_apll_ssc_mode
[21:20]	R/W	0	pcie_apll_ssc_offset
[19:18]	R/W	0	pcie_apll_str_m
[15:0]	R/W	0	pcie_apll_reserve

**Table 7-80 HHI\_PCIE\_PLL\_CNTL3 0x29**

Bit(s)	R/W	Default	Description
[31]	R/W	0	pcie_apll_afc_bypass_en
[29:28]	R/W	0	pcie_apll_afc_hold_t
[26:20]	R/W	0	pcie_apll_afc_in
[19]	R/W	0	pcie_apll_afc_nt
[18:17]	R/W	0	pcie_apll_afc_div
[16]	R/W	0	pcie_apll_bias_lpf_en
[15:12]	R/W	0	pcie_apll_cp_icap
[11:8]	R/W	0	pcie_apll_cp_ires
[5:4]	R/W	0	pcie_apll_cpi

**Table 7-81 HHI\_PCIE\_PLL\_CNTL4 0x2A**

Bit(s)	R/W	Default	Description
[31]	R/W	0	pcie_apll_shift_en
[27:26]	R/W	0	pcie_apll_shift_t
[25:24]	R/W	0	pcie_apll_shift_v
[23]	R/W	0	pcie_apll_vctrl_mon_en
[21:20]	R/W	0	pcie_apll_lpf_cap
[19:16]	R/W	0	pcie_apll_lpf_capadj
[13:12]	R/W	0	pcie_apll_lpf_res
[11]	R/W	0	pcie_apll_lpf_sf

Bit(s)	R/W	Default	Description
[10]	R/W	0	pcie_apll_lvr_od_en
[9]	R/W	0	pcie_apll_refclk_mon_en
[8]	R/W	0	pcie_apll_fbclk_mon_en
[7]	R/W	0	pcie_apll_load
[6]	R/W	0	pcie_apll_load_en

Table 7-82 HHI\_PCIE\_PLL\_CNTL5 0x2B

Bit(s)	R/W	Default	Description
[30:28]	R/W	0	pcie_hcsl_adj_ldo
[27]	R/W	0	pcie_hcsl_bgp_en
[24:20]	R/W	0	pcie_hcsl_bgr_adj
[19]	R/W	0	pcie_hcsl_bgr_start
[16:12]	R/W	0	pcie_hcsl_bgr_vref
[11:8]	R/W	0	pcie_hcsl_by_imp_in
[7]	R/W	0	pcie_hcsl_by_imp
[6]	R/W	0	pcie_hcsl_cal_en
[5]	R/W	0	pcie_hcsl_cal_rstn
[4]	R/W	0	pcie_hcsl_edgedrv_en
[3]	R/W	0	pcie_hcsl_en0
[2]	R/W	0	pcie_hcsl_in_en
[1]	R/W	0	pcie_hcsl_sel_pw
[0]	R/W	0	pcie_hcsl_sel_str

Table 7-83 HHI\_PCIE\_PLL\_STS 0x2C

Bit(s)	R/W	Default	Description
[31]	R	0	pcie_apll_lock
[30]	R	0	pcie_hcsl_cal_done
[29]	R	0	pcie_apll_afc_done

Table 7-84 HHI\_XTAL\_DIVN\_CNTL 0x2f

Bit(s)	R/W	Default	Description
12	R/W	0	crt_clk25_en
11	R/W	0	crt_clk24_en
10	R/W	0	clk24_div2_en
7:0	R/W	0	clk25_div



**Table 7-85 HHI\_GCLK2\_MPEG0 0x30**

Bit(s)	R/W	Default	Description
31-0	R/W	All 0	Bits [31:0] of the composite MPEG clock gating register

**Table 7-86 HHI\_GCLK2\_MPEG1 0x31**

Bit(s)	R/W	Default	Description
31-0	R/W	All 0	Bits [63:32] of the composite MPEG clock gating register

**Table 7-87 HHI\_GCLK2\_MPEG2 0x32**

Bit(s)	R/W	Default	Description
31-0	R/W	All 0	Bits [63:32] of the composite MPEG clock gating register

**Table 7-88 HHI\_GCLK2\_OTHER 0x34**

Bit(s)	R/W	Default	Description
31-0	R/W	All 0	Bits [31:0] of the composite Other clock gating register

**Table 7-89 HHI\_HIFI\_PLL\_CNTL0 0x36**

Bit(s)	R/W	Default	Description
[31]	R	0	hifi_dppll_lock
[30]	R	0	hifi_dppll_lock_a
[29]	R/W	1	hifi_dppll_reset
[28]	R/W	0	hifi_dppll_en
[17:16]	R/W	0	hifi_dppll_od
[14:10]	R/W	0	hifi_dppll_N
[7:0]	R/W	0	hifi_dppll_M

**Table 7-90 HHI\_HIFI\_PLL\_CNTL1 0x37**

Bit(s)	R/W	Default	Description
[18:0]	R	0	hifi_dppll_frac

**Table 7-91 HHI\_HIFI\_PLL\_CNTL2 0x38**

Bit(s)	R/W	Default	Description
[22:20]	R/W	0	hifi_dppll_fref_sel
[17:16]	R/W	0	hifi_dppll_os_ssc

Bit(s)	R/W	Default	Description
[15:12]	R/W	0	hifi_dppll_ssc_str_m
[8]	R/W	0	hifi_dppll_ssc_en
[7:4]	R/W	0	hifi_dppll_ssc_dep_sel
[1:0]	R/W	0	hifi_dppll_ss_mode

Table 7-92 HHI\_HIFI\_PLL\_CNTL3 0x39

Bit(s)	R/W	Default	Description
31	R/W	0	hifi_dppll_afc_bypass
30	R/W	0	hifi_dppll_afc_clk_sel
29	R/W	0	hifi_dppll_code_new
28	R/W	0	hifi_dppll_dco_m_en
27	R/W	0	hifi_dppll_dco_sdm_en
25	R/W	0	hifi_dppll_div_mode
24	R/W	0	hifi_dppll_fast_lock
23	R/W	0	hifi_dppll_fb_pre_div
22	R/W	0	hifi_dppll_filter_mode
21	R/W	0	hifi_dppll_fix_en
20	R/W	0	hifi_dppll_freq_shift_en
19	R/W	0	hifi_dppll_load
18	R/W	0	hifi_dppll_load_en
17	R/W	0	hifi_dppll_lock_f
16	R/W	0	hifi_dppll_pulse_width_en
15	R/W	0	hifi_dppll_sdmnc_en
14	R/W	0	hifi_dppll_sdmnc_mode
13	R/W	0	hifi_dppll_sdmnc_range
12	R/W	0	hifi_dppll_tdc_en
11	R/W	0	hifi_dppll_tdc_mode_sel
10	R/W	0	hifi_dppll_wait_en

Table 7-93 HHI\_HIFI\_PLL\_CNTL4 0x3A

Bit(s)	R/W	Default	Description
[30:28]	R/W	0	hifi_dppll_alpha
[26:24]	R/W	0	hifi_dppll_rou
[22:20]	R/W	0	hifi_dppll_lambda1
[18:16]	R/W	0	hifi_dppll_lambda0

Bit(s)	R/W	Default	Description
[13:12]	R/W	0	hifi_dppll_acq_gain
[11:8]	R/W	0	hifi_dppll_filter_pvt2
[7:4]	R/W	0	hifi_dppll_filter_pvt1
[1:0]	R/W	0	hifi_dppll_pfd_gain

Table 7-94 HHI\_HIFI\_PLL\_CNTL5 0x3B

Bit(s)	R/W	Default	Description
[30:28]	R/W	0	hifi_dppll_adj_vco_ldo
[27:24]	R/W	0	hifi_dppll_lm_w
[21:16]	R/W	0	hifi_dppll_lm_s
[15:0]	R/W	0	hifi_dppll_reve

Table 7-95 HHI\_HIFI\_PLL\_CNTL6 0x3C

Bit(s)	R/W	Default	Description
[31:30]	R/W	0	hifi_dppll_afc_hold_t
[29:28]	R/W	0	hifi_dppll_lkw_sel
[27:26]	R/W	0	hifi_dppll_dco_sdm_clk_sel
[25:24]	R/W	0	hifi_dppll_afc_in
[23:22]	R/W	0	hifi_dppll_afc_nt
[21:20]	R/W	0	hifi_dppll_vc_in
[19:18]	R/W	0	hifi_dppll_lock_long
[17:16]	R/W	0	hifi_dppll_freq_shift_v
[14:12]	R/W	0	hifi_dppll_data_sel
[10:8]	R/W	0	hifi_dppll_sdmnc_ulms
[6:0]	R/W	0	hifi_dppll_sdmnc_power

Table 7-96 HHI\_HIFI\_PLL\_STS 0x3D

Bit(s)	R/W	Default	Description
[31]	R	0	hifi_dppll_lock
[30]	R	0	hifi_dppll_lock_a
[29]	R	0	hifi_dppll_afc_done
[22:16]	R	0	hifi_dppll_sdmnc_monitor
[9:0]	R	0	hifi_dppll_out_rsv

**Table 7-97 HHI\_TIMER90K 0x3F**

Bit(s)	R/W	Default	Description
31-16	R/W	0	Unused
15-0	R/W	0x384	90khz divider

**Table 7-98 HHI\_NANOQ\_MEM\_PD\_REG0 0x46**

Bit(s)	R/W	Default	Description
31~0	R/W	0xffffffff	todo

**Table 7-99 HHI\_NANOQ\_MEM\_PD\_REG1 0x47**

Bit(s)	R/W	Default	Description
31~0	R/W	0xffffffff	todo

**Table 7-100 HHI\_VIID\_CLK\_DIV 0x4a**

Bit(s)	R/W	Default	Description
31-28	R/W	0	DAC0_CLK_SEL
27-24	R/W	0	DAC1_CLK_SEL
23-20	R/W	0	DAC2_CLK_SEL
19	R/W	0	Select adc_pll_clk_b2 to be cts_clk_vdac
18	R/W	0	Unused
17	R/W	0	V2_cntl_clk_div_reset
16	R/W	0	V2_cntl_clk_div_en
15-12	R/W	0	Encl_clk_sel
14-8	R/W	0	Unused
7-0	R/W	0	V2_cntl_xd0

**Table 7-101 HHI\_VIID\_CLK\_CNTL 0x4b**

Bit(s)	R/W	Default	Description
31-20	R/W	0	Unused
19	R/W	0	V2_cntl_clk_en0
18-16	R/W	0	V2_cntl_clk_in_sel
15	R/W	0	V2_cntl_soft_reset
14-5	R/W	0	Unused
4	R/W	0	V2_cntl_div12_en
3	R/W	0	V2_cntl_div6_en
2	R/W	0	V2_cntl_div4_en

Bit(s)	R/W	Default	Description
1	R/W	0	V2_cntl_div2_en
0	R/W	0	V2_cntl_div1_en

**Table 7-102 HHI\_GCLK\_LOCK 0x4F**

wr	rd
SP/SCP sec only	all access

Bit(s)	R/W	Default	Description
31	R/W	0	enable error return if write gclk after lock
8	R/W	0	lock gclk2_other
7	R/W	0	lock gclk2_mpeg2
6	R/W	0	lock gclk2_mpeg1
5	R/W	0	lock gclk2_mpeg0
4	R/W	0	lock gclk_sp_mpeg
3	R/W	0	lock gclk1_other
2	R/W	0	lock gclk1_mpeg2
1	R/W	0	lock gclk1_mpeg1
0	R/W	0	lock gclk1_mpeg0

**Table 7-103 HHI\_GCLK\_MPEG0 0x50**

Bit(s)	R/W	Default	Description
31-0	R/W	All 1	Bits [31:0] of the composite MPEG clock gating register

**Table 7-104 HHI\_GCLK\_MPEG1 0x51**

Bit(s)	R/W	Default	Description
31-0	R/W	All 1	Bits [63:32] of the composite MPEG clock gating register

**Table 7-105 HHI\_GCLK\_MPEG2 0x52**

Bit(s)	R/W	Default	Description
31-0	R/W	All 1	Bits [63:32] of the composite MPEG clock gating register

**Table 7-106 HHI\_GCLK\_OTHER 0x54**

Bit(s)	R/W	Default	Description
31-0	R/W	All 1	Bits [31:0] of the composite Other clock gating register

Table 7-107 HHI\_GCLK\_SP\_MPEG 0x55

Bit(s)	R/W	Default	Description
31-0	R/W	0	bits[31:0] of secure module clock gating.

Table 7-108 HHI\_SYS\_CPU\_CLK\_CNTL1 0x57

Bit(s)	R/W	Default	Description
31-25	R/W	0	Reserved
24	R/W	0	Sys_pll_div16_en
23	R/W	0	A55_trace_clk_DIS: Set to 1 to manually disable the A55_trace_clk when changing the mux selection. Typically this bit is set to 0 since the clock muxes can switch without glitches. This is a "just in case" bit
22:20	R/W	5	0 A55_trace_clk: A55 clock divided by 2 A55 clock divided by 3 A55 clock divided by 4 A55 clock divided by 5 A55 clock divided by 6 A55 clock divided by 7 A55 clock divided by 8
19	R/W	0	Timestamp CNTCLKEN_dis
18	R/W	0	AXI_CLK_DIS: Set to 1 to manually disable the AXI clock when changing the mux selection. Typically this bit is set to 0 since the clock muxes can switch without glitches. This is a "just in case" bit
17	R/W	0	ATCLK_dis
16	R/W	0	APB_CLK_DIS: Set to 1 to manually disable the APB clock when changing the mux selection. Typically this bit is set to 0 since the clock muxes can switch without glitches. This is a "just in case" bit
15	R/W	0	Timestamp CNTCLKEN
14~12	R/W	0	Timestamp cntclk mux(not used)
11~9	R/W	1	0 AXI_CLK_MUX: A55 clock divided by 2 A55 clock divided by 3 A55 clock divided by 4 A55 clock divided by 5 A55 clock divided by 6 A55 clock divided by 7 A55 clock divided by 8
8~6	R/W	2	0 atCLK_MUX: A55 clock divided by 2 A55 clock divided by 3 A55 clock divided by 4 A55 clock divided by 5 A55 clock divided by 6 A55 clock divided by 7 A55 clock divided by 8
5~3	R/W	4	0 APB_CLK_MUX: A55 clock divided by 2 A55 clock divided by 3 A55 clock divided by 4 A55 clock divided by 5 A55 clock divided by 6 A55 clock divided by 7 A55 clock divided by 8
2	R/W	0	Soft_reset
1	R/W	0	Sys_cpu_clk_div16_en
0	R/W	0	Pclk_en_dbg

Table 7-109 HHI\_VID\_CLK\_DIV 0x59

Bit(s)	R/W	Default	Description
31-28	R/W	0	ENCI_CLK_SEL
27-24	R/W	0	ENCP_CLK_SEL
23-20	R/W	0	ENCT_CLK_SEL
19-18	R/W	0	UNUSED
17	R/W	0	CLK_DIV_RESET
16	R/W	0	CLK_DIV_EN
15-8	R/W	1	XD1
7-0	R/W	1	XD0

Table 7-110 HHI\_MPEG\_CLK\_CNTL 0x5d

Bit(s)	R/W	Default	Description
31	R/W	0	NEW_DIV_EN: If this bit is set to 1, then bits[30:16] make up the clk81 divider. If this bit is 0, then bits[6:0] dictate the divider value. This is a new feature that allows clk81 to be divided down to a very slow frequency.
30~16	R/W	0	NEW_DIV: New divider value if bit[31] = 1
15	R/W	0	Production clock enable
14-12	R.W	6	MPEG_CLK_SEL (See clock document)
11-10	R/W	0	unused
9	R.W	0	RTC Oscillator Enable: Set this bit to 1 to connect the RTC 32khz oscillator output as the XTAL input for the divider above
8	R/W	0	Divider Mux: 0 = the ARC clock and the MPEG system clock are connected to the 27Mhz crystal. 1 = the ARC clock and the MPEG system clock are connected to the MPEG PLL divider
7	R/W	1	PLL Mux: 0 = all circuits associated with the MPEG PLL are connected to 27Mhz. 1 = all circuits associated with the MPEG PLL are connected to the MPEG PLL
6-0	R/W	0	PLL Output divider. The MPEG System clock equals the video PLL clock frequency divided by (N+1). Note: N must be odd (1,3,5,...) so that the MPEG clock is divided by an even number to generate a 50% duty cycle.

Table 7-111 HHI\_VID\_CLK\_CNTL 0x5f

Bit(s)	R/W	Default	Description
31-21	R/W	0	TCON_CLK0_CTRL
20	R/W	0	CLK_EN1
19	R/W	0	CLK_EN0
18-16	R/W	0	CLK_IN_SEL
15	R/W	0	SOFT_RESET
14	R/W	0	PH23_ENABLE
13	R/W	0	DIV12_PH23

Bit(s)	R/W	Default	Description
12-5	R/W	0	UNUSED
4	R/W	0	DIV12_EN
3	R/W	0	DIV6_EN
2	R/W	0	DIV4_EN
1	R/W	0	DIV2_EN
0	R/W	0	DIV1_EN

Table 7-112 HHI\_TS\_CLK\_CNTL 0x64

Bit(s)	R/W	Default	Description
8	R/W	0	ts_clk clk_en
7:0	R/W	0	ts_clk clk_div

Table 7-113 HHI\_VID\_CLK\_CNTL2 0x65

Bit(s)	R/W	Default	Description
31-16	R	0	
15-9	R/W	0	Reserved
8	R/W	0	Atv demod vdac gated clock control
7	R/W	1	LCD_AN_CLK_PHY2 gated clock control. 1 = enable
6	R/W	1	LCD_AN_CLK_PH3 gated clock control
5	R/W	1	HDMI_TX_PIXEL_CLK gated clock control
4	R/W	1	VDAC_clk gated clock control
3	R/W	1	ENCL gated clock control
2	R/W	1	ENCP gated clock control
1	R/W	1	ENCT gated clock control
0	R/W	1	ENCI gated clock control

Table 7-114 HHI\_SYS\_CPU\_CLK\_CNTL0 0x67

Bit(s)	R/W	Default	Description
31	R	0	Final_mux_sel
30	R	0	Final_dyn_mux_sel
29	R	0	Busy_cnt
28	R	0	busy
26	R/W	0	Dyn_enable
25-20	R/W	0	Mux1_divn_tcnt
18	R/W	0	Postmux1



Bit(s)	R/W	Default	Description
17-16	R/W	0	Premux1
15	R/W	0	Manual_mux_mode
14	R/W	0	Manual_mode_post
13	R/W	0	Manual_mode_pre
12	R/W	0	Force_update_t
11	R/W	0	Final_mux_sel
10	R/W	0	Final_dyn_mux_sel
9-4	R/W	0	mux0_divn_tcnt
3	R/W	0	Rev
2	R/W	0	Postmux0
1-0	R/W	0	Premux0

Table 7-115 HHI\_VID\_PLL\_CLK\_DIV 0x68

Bit(s)	R/W	Default	Description
31~24	R	0	RESERVED
23~20	R/W	0	Reserved
19	R/W	0	CLK_FINAL_EN
18	R/W	0	CLK_DIV1
17~16	R/W	0	CLK_SEL
15	R/W	0	SET_PRESET
14-0	R/W	0	SHIFT_PRESET

Table 7-116 HHI\_MALI\_CLK\_CNTL 0x6c

Bit(s)	R/W	Default	Description
31	R/W	0	0: mali_clk_cntl[14:0]; 1: mali_clk_cntl[30:16];
27~25	R/W	0	CLK_SEL: See the Clock Tree document for information related to cts_mali_clk 0:oscin; 1:gp0pll; 2:hifi_pll; 3:fclk_div2p5; 4:fclk_div3; 5:fclk_div4; 6:fclk_div5; 7: fclk_div7;
24	R/W	0	CLK_EN: See the Clock Tree document for information related to cts_mali_clk
23	R/W	0	Reserved
22~16	R/W	0	CLK_DIV: See the Clock Tree document for information related to cts_mali_clk
15~12			
11~9	R/W	0	CLK_SEL: See the Clock Tree document for information related to cts_mali_clk 0:oscin; 1:gp0pll; 2:mp1l2; 3:mp1l1; 4:fclk_div7; 5:fclk_div4; 6:fclk_div3; 7:fclk_div5;
8	R/W	0	CLK_EN: See the Clock Tree document for information related to cts_mali_clk

Bit(s)	R/W	Default	Description
7	R/W	0	Reserved
6-0	R/W	0	CLK_DIV: See the Clock Tree document for information related to cts_mali_clk

Table 7-117 HHI\_VPU\_CLKC\_CNTL 0x6D

Bit(s)	R/W	Default	Description
31	R/W	0	Final mux sel
30-29	R/W	0	Reserved
27~25	R/W	0	CLK_SEL: See the Clock Tree document for information related to cts_vpu_clkc 0:fclk_div4; 1:fclk_div3; 2:fclk_div5; 3:fclk_div7; 4:mp1l1; 5:vid_pll; 6:mp1l2; 7: gp0pll;
24	R/W	0	CLK_EN: See the Clock Tree document for information related to cts_vpu_clkc
23	R/W	0	Reserved
22~16	R/W	0	CLK_DIV: See the Clock Tree document for information related to cts_vpu_clkc
15~12			
11~9	R/W	0	CLK_SEL: See the Clock Tree document for information related to cts_vpu_clkc 0:fclk_div4; 1:fclk_div3; 2:fclk_div5; 3:fclk_div7; 4:mp1l1; 5:vid_pll; 6:mp1l2; 7: gp0pll;
8	R/W	0	CLK_EN: See the Clock Tree document for information related to cts_vpu_clkc
7	R/W	0	Reserved
6-0	R/W	0	CLK_DIV: See the Clock Tree document for information related to cts_vpu_clkc

Table 7-118 HHI\_VPU\_CLK\_CNTL 0x6F

Bit(s)	R/W	Default	Description
31	R/W	0	Final mux sel
30-29	R/W	0	Reserved
27~25	R/W	0	CLK_SEL: See the Clock Tree document for information related to cts_vpu_clk 0:fclk_div3; 1:fclk_div4; 2:fclk_div5; 3:fclk_div7; 4:mp1l1; 5:vid_pll; 6:hifi_pll; 7: gp0_pll;
24	R/W	0	CLK_EN: See the Clock Tree document for information related to cts_vpu_clk
23	R/W	0	Reserved
22~16	R/W	0	CLK_DIV: See the Clock Tree document for information related to cts_vpu_clk
15~12			
11~9	R/W	0	CLK_SEL: See the Clock Tree document for information related to cts_vpu_clk 0:fclk_div3; 1:fclk_div4; 2:fclk_div5; 3:fclk_div7; 4:mp1l1; 5:vid_pll; 6:hifi_pll; 7: gp0_pll;
8	R/W	0	CLK_EN: See the Clock Tree document for information related to cts_vpu_clk
7	R/W	0	Reserved
6-0	R/W	0	CLK_DIV: See the Clock Tree document for information related to cts_vpu_clk

Table 7-119 HHI\_NN\_CNTL 0x71

Bit(s)	R/W	Default	Description
31~30	R/W	0x3	todo

Table 7-120 HHI\_NN\_CLK\_CNTL 0x72

Bit(s)	R/W	Default	Description
27:25	R/W	0	NN_core_clk; clk_sel 0:oscin; 1:gp0_pll; 2:hifi_pll; 3:fclk_div2p5;; 4:fclk_div3; 5:fclk_div4; 6:fclk_div5; 7:fclk_div7;
24	R/W	0	NN_core_clk; clk_en
22:16	R/W	0	NN_core_clk; clk_div
11:9	R/W	0	NN_axi_clk; clk_sel 0:oscin; 1:gp0_pll; 2:hifi_pll; 3:fclk_div2p5;; 4:fclk_div3; 5:fclk_div4; 6:fclk_div5; 7:fclk_div7;
8	R/W	0	NN_axi_clk; clk_en
6:0	R/W	0	NN_axi_clk; clk_div

Table 7-121 HHI\_HDMI\_CLK\_CNTL 0x73

Bit(s)	R/W	Default	Description
31-20	R/W	0	Reserved
19~16	R/W	0	crt_hdmi_pixel_clk_sel
15~11	R/W	0	Reserved
10~9	R/W	0	CLK_SEL: See the Clock Tree document for information related to cts_hdmi_sys_clk 0:oscin; 1:fclk_div4; 2:fclk_div3; 3:fclk_div5;
8	R/W	0	CLK_EN: See the Clock Tree document for information related to cts_hdmi_sys_clk
7	R/W	0	Reserved
6-0	R/W	0	CLK_DIV: See the Clock Tree document for information related to cts_hdmi_sys_clk

Table 7-122 HHI\_ETH\_CLK\_CNTL 0x76

Bit(s)	R/W	Default	Description
17	R/W	0	eth_mac_speed; 0:div 20; 1: div2;
16	R/W	0	invert clk_rmii_pad_i
13	R/W	0	invert clk_rmii_pad_o
12	R/W	0	clk_rmii_pad_o; 0: rmii_clk; 1: rmii_div;
11:9	R/W	0	rmii_clk; clk_sel; 0: fclk_div2; 7: clk_rmii_pad_i;
8	R/W	0	rmii_clk; clk_en

Bit(s)	R/W	Default	Description
7	R/W	0	eth_clk125M; clk_en;
6:0	R/W	0	rmii_clk; clk_div

Table 7-123 HHI\_VDEC\_CLK\_CNTL 0x78

Bit(s)	R/W	Default	Description
31-28	R/W	0	Reserved
27~25	R/W	0	CLK_SEL: See the Clock Tree document for information related to cts_hcodec_clk 0:fclk_div2p5; 1:fclk_div3; 2:fclk_div4; 3:fclk_div5; 4:fclk_div7; 5:hifi_pll; 6:gp0pll; 7:oscin;
24	R/W	0	CLK_EN: See the Clock Tree document for information related to cts_hcodec_clk
23	R/W	0	Reserved
22~16	R/W	0	CLK_DIV: See the Clock Tree document for information related to ctshcodec_clk
15~12	R/W	0	Reserved
11~9	R/W	0	CLK_SEL: See the Clock Tree document for information related to cts_vdec_clk 0:fclk_div2p5; 1:fclk_div3; 2:fclk_div4; 3:fclk_div5; 4:fclk_div7; 5:hifi_pll; 6:gp0pll; 7:oscin;
8	R/W	0	CLK_EN: See the Clock Tree document for information related to cts_vdec_clk
7	R/W	0	Reserved
6-0	R/W	0	CLK_DIV: See the Clock Tree document for information related to cts_vdec_clk

Table 7-124 HHI\_VDEC2\_CLK\_CNTL 0x79

Bit(s)	R/W	Default	Description
31-28	R/W	0	Reserved
27~25	R/W	0	HEVCB_CLK_SEL: See the Clock Tree document for information related to cts_hevcb_clk 0:fclk_div2p5; 1:fclk_div3; 2:fclk_div4; 3:fclk_div5; 4:fclk_div7; 5:hifi_pll; 6:gp0pll; 7:oscin;
24	R/W	0	HEVCB_CLK_EN: See the Clock Tree document for information related to cts_hevcb_clk
23	R/W	0	Reserved
22~16	R/W	0	HEVCB_CLK_DIV: See the Clock Tree document for information related to cts_hevcb_clk
15~12			
11~9	R/W	0	HEVCF_CLK_SEL: See the Clock Tree document for information related to cts_hevcf_clk 0:fclk_div2p5; 1:fclk_div3; 2:fclk_div4; 3:fclk_div5; 4:fclk_div7; 5:hifi_pll; 6:gp0pll; 7:oscin;
8	R/W	0	HEVCF_CLK_EN: See the Clock Tree document for information related to cts_hevcf_clk
7	R/W	0	Reserved
6-0	R/W	0	HEVCF_CLK_DIV: See the Clock Tree document for information related to cts_hevcf_clk

Table 7-125 HHI\_VDEC3\_CLK\_CNTL 0x7a

Bit(s)	R/W	Default	Description
31	R/W	0	cts_hcodec_clk; 0: use VDEC_CLK_CNTL; 1: use VDEC3_CLK_CNTL;
27~25	R/W	0	CLK_SEL: See the Clock Tree document for information related to cts_hcodec_clk 0:fclk_div2p5; 1:fclk_div3; 2:fclk_div4; 3:fclk_div5; 4:fclk_div7; 5:hifi_pll; 6:gp0pll; 7:oscin;
24	R/W	0	CLK_EN: See the Clock Tree document for information related to cts_hcodec_clk
23	R/W	0	Reserved
22~16	R/W	0	CLK_DIV: See the Clock Tree document for information related to ctshcodec_clk
15	R/W	0	cts_vdec_clk; 0: use VDEC_CLK_CNTL; 1: use VDEC3_CLK_CNTL;
11~9	R/W	0	CLK_SEL: See the Clock Tree document for information related to cts_vdec_clk 0:fclk_div2p5; 1:fclk_div3; 2:fclk_div4; 3:fclk_div5; 4:fclk_div7; 5:hifi_pll; 6:gp0pll; 7:oscin;
8	R/W	0	CLK_EN: See the Clock Tree document for information related to cts_vdec_clk
7	R/W	0	Reserved
6-0	R/W	0	CLK_DIV: See the Clock Tree document for information related to cts_vdec_clk

Table 7-126 HHI\_VDEC4\_CLK\_CNTL 0x7b

Bit(s)	R/W	Default	Description
31	R/W	0	HEVCB_CLK; 0: use VDEC2_CLK_CNTL; 1: use VDEC4_CLK_CNTL;
27~25	R/W	0	HEVCB_CLK_SEL: See the Clock Tree document for information related to cts_hevcb_clk 0:fclk_div2p5; 1:fclk_div3; 2:fclk_div4; 3:fclk_div5; 4:fclk_div7; 5:hifi_pll; 6:gp0pll; 7:oscin;
24	R/W	0	HEVCB_CLK_EN: See the Clock Tree document for information related to cts_hevcb_clk
23	R/W	0	Reserved
22~16	R/W	0	HEVCB_CLK_DIV: See the Clock Tree document for information related to cts_hevcb_clk
15	R/W	0	HEVCF_CLK; 0: use VDEC2_CLK_CNTL; 1: use VDEC4_CLK_CNTL;
11~9	R/W	0	HEVCF_CLK_SEL: See the Clock Tree document for information related to cts_hevcf_clk 0:fclk_div2p5; 1:fclk_div3; 2:fclk_div4; 3:fclk_div5; 4:fclk_div7; 5:hifi_pll; 6:gp0pll; 7:oscin;
8	R/W	0	HEVCF_CLK_EN: See the Clock Tree document for information related to cts_hevcf_clk
7	R/W	0	Reserved
6-0	R/W	0	HEVCF_CLK_DIV: See the Clock Tree document for information related to cts_hevcf_clk

Table 7-127 HHI\_HDCP22\_CLK\_CNTL 0x7c

Bit(s)	R/W	Default	Description
31-0	R/W	0	Reserved
26-25	R/W	0	Clk_sel: 0:cts_oscin_clk 1:fclk_div4 2:fclk_div3 3:fclk_div5
24	R/W	0	Clk_en
23-0	R/W	0	Clk_div

Table 7-128 HHI\_VAPBCLK\_CNTL 0x7d

Bit(s)	R/W	Default	Description
31	R/W	0	Final_mux_sel
30	R/W	0	Enable
29-28	R/W	0	Reserved
27-25	R/W	0	Mux1_sel: 0:fclk_div4 1:fclk_div3 2:fclk_div5 3:fclk_div7 4:mp1_clk_out 5:vid_pll_clk 6: mp2_clk_out 7:fclk_div2p5
24	R/W	0	Mux1_en
23	R/W	0	Reserved
22-16	R/W	0	Mux1_div
15-12	R/W	0	Reserved
11-9	R/W	0	Mux0_sel,as mux1_sel
8	R/W	0	Mux0_en
7	R/W	0	Reserved
6-0	R/W	0	Mux0_div

Table 7-129 HHI\_VPU\_CLKB\_CNTL 0x83

Bit(s)	R/W	Default	Description
31-25	R/W	0	Reserved
24	R/W	0	Cts_vpu_clkb_tmp en
21-20	R/W	0	Cts_vpu_clkb_tmp sel
19-16	R/W	0	Cts_vpu_clkb_tmp div
9	R/W	0	Vpu_clkb_latch_en
8	R/W	0	Vpu_clkb_en
7-0	R/W	0	Vpu_clkb_div

Table 7-130 HHI\_SYS\_CPU\_CLK\_CNTL2 0x84

Bit(s)	R/W	Default	Description
31	R	0	Cpu1:Final_mux_sel
30	R	0	Cpu1:Final_dyn_mux_sel
29	R	0	Cpu1:Busy_cnt
28	R	0	Cpu1:busy
26	R/W	0	Cpu1:Dyn_enable
25-20	R/W	0	Cpu1:Mux1_divn_tcmt
18	R/W	0	Cpu1:Postmux1
17-16	R/W	0	Cpu1:Premux1
15	R/W	0	Cpu1:Manual_mux_mode
14	R/W	0	Cpu1:Manual_mode_post
13	R/W	0	Cpu1:Manual_mode_pre
12	R/W	0	Cpu1:Force_update_t
11	R/W	0	Cpu1:Final_mux_sel
10	R/W	0	Cpu1:Final_dyn_mux_sel
9-4	R/W	0	Cpu1:mux0_divn_tcmt
3	R/W	0	Rev
2	R/W	0	Cpu1:Postmux0
1-0	R/W	0	Cpu1:Premux0

Table 7-131 HHI\_SYS\_CPU\_CLK\_CNTL3 0x85

Bit(s)	R/W	Default	Description
31	R	0	Cpu2:Final_mux_sel
30	R	0	Cpu2:Final_dyn_mux_sel
29	R	0	Cpu2:Busy_cnt
28	R	0	Cpu2:busy
26	R/W	0	Cpu2:Dyn_enable
25-20	R/W	0	Cpu2:Mux1_divn_tcmt
18	R/W	0	Cpu2:Postmux1
17-16	R/W	0	Cpu2:Premux1
15	R/W	0	Cpu2:Manual_mux_mode
14	R/W	0	Cpu2:Manual_mode_post
13	R/W	0	Cpu2:Manual_mode_pre
12	R/W	0	Cpu2:Force_update_t
11	R/W	0	Cpu2:Final_mux_sel

Bit(s)	R/W	Default	Description
10	R/W	0	Cpu2:Final_dyn_mux_sel
9-4	R/W	0	Cpu2:mux0_divn_tcnt
3	R/W	0	Rev
2	R/W	0	Cpu2:Postmux0
1-0	R/W	0	Cpu2:Premux0

Table 7-132 HHI\_SYS\_CPU\_CLK\_CNTL4 0x86

Bit(s)	R/W	Default	Description
31	R	0	Cpu3:Final_mux_sel
30	R	0	Cpu3:Final_dyn_mux_sel
29	R	0	Cpu3:Busy_cnt
28	R	0	Cpu3:busy
26	R/W	0	Cpu3:Dyn_enable
25-20	R/W	0	Cpu3:Mux1_divn_tcnt
18	R/W	0	Cpu3:Postmux1
17-16	R/W	0	Cpu3:Premux1
15	R/W	0	Cpu3:Manual_mux_mode
14	R/W	0	Cpu3:Manual_mode_post
13	R/W	0	Cpu3:Manual_mode_pre
12	R/W	0	Cpu3:Force_update_t
11	R/W	0	Cpu3:Final_mux_sel
10	R/W	0	Cpu3:Final_dyn_mux_sel
9-4	R/W	0	Cpu3:mux0_divn_tcnt
3	R/W	0	Rev
2	R/W	0	Cpu3:Postmux0
1-0	R/W	0	Cpu3:Premux0

Table 7-133 HHI\_SYS\_CPU\_CLK\_CNTL5 0x87

Bit(s)	R/W	Default	Description
31	R	0	dsu:Final_mux_sel
30	R	0	dsu:Final_dyn_mux_sel
29	R	0	dsu:Busy_cnt
28	R	0	dsu:busy
26	R/W	0	dsu:Dyn_enable
25-20	R/W	0	dsu:Mux1_divn_tcnt



Bit(s)	R/W	Default	Description
18	R/W	0	dsu:Postmux1
17-16	R/W	0	dsu:Premux1
15	R/W	0	dsu:Manual_mux_mode
14	R/W	0	dsu:Manual_mode_post
13	R/W	0	dsu:Manual_mode_pre
12	R/W	0	dsu:Force_update_t
11	R/W	0	dsu:Final_mux_sel
10	R/W	0	dsu:Final_dyn_mux_sel
9-4	R/W	0	dsu:mux0_divn_tcmt
3	R/W	0	Rev
2	R/W	0	dsu:Postmux0
1-0	R/W	0	dsu:Premux0

Table 7-134 HHI\_SYS\_CPU\_CLK\_CNTL6 0x88

Bit(s)	R/W	Default	Description
27-24	R/W	0	Cpu_clk_sync_mux_sel
23	R/W	0	Sys_pll_mux_sel
22-20	R/W	0	Sys_clk_mux_sel
11	R/W	0	Tsclk_dis
10-8	R/W	0	Tsclk_mux
7	R/W	0	Periphclk_dis
6-4	R/W	0	Periphclk_mux
3	R/W	0	Gicclk_dis
2-0	R/W	0	Gicclk_mux

Table 7-135 HHI\_GEN\_CLK\_CNTL 0x8a

Bit(s)	R/W	Default	Description
31-17	R/W	0	Reserved
16~12	R/W	0	CLK_SEL: 0:cts_oscclk 1:rtc_oscclk 2:sys_cpu_clk_div16 3:ddr_dppll_pt_clk 4:vid_pll_clk 5:gp0_pll_clk 6:gp1_pll_clk 7:hifi_pll_clk 8:pcie_clk_in_n 9:pcie_clk_in_p 12:cts_msr_clk 16:acodec_dac_clk 17:sys_cpu_clk_div16; 20:fclk_div2; 21:fclk_div3; 22:fclk_div4; 23:fclk_div5; 24:fclk_div7; 25:mpll0_clk; 26:mpll1_clk; 27:mpll2_clk; 28:mpll3_clk;
11	R/W	0	CLK_EN: See the Clock Tree document for information related to gen_clk_out
10~0	R/W	0	CLK_DIV: See the Clock Tree document for information related to gen_clk_out

Below register is for clock control for cts\_vdin\_meas\_clk

**Table 7-136 HHI\_VDIN\_MEAS\_CLK\_CNTL 0x94**

Bit(s)	R/W	Default	Description
31-12	R/W	0	unused
11-9	R/W	0	CLK_SEL: See the Clock Tree document for information related to cts_vdin_meas_clk 0:oscin; 1:fclk_div4; 2:fclk_div3; 3:fclk_div5; 4:vid_pll; 5:gp0_pll; 6:fclk_div2; 7:fclk_div7;
8	R/W	0	CLK_EN: See the Clock Tree document for information related to cts_vdin_meas_clk
6-0	R/W	48	CLK_DIV: See the Clock Tree document for information related to cts_vdin_meas_clk

**Table 7-137 HHI\_NAND\_CLK\_CNTL 0x97**

Bit(s)	R/W	Default	Description
31-12	R/W	0	unused
11-9	R/W	0	CLK_SEL: 0:cts_oscin_clk 1:fclk_div2 2:fclk_div3 3:fclk_div5 4:fclk_div7 5:mp2_clk_out 6:mp3_clk_out 7:gp0_pll_clk
8			Reserved
7	R/W	1	CLK_EN:
6-0	R/W	0	CLK_DIV

**Table 7-138 HHI\_SD\_EMMC\_CLK\_CNTL 0x99**

Bit(s)	R/W	Default	Description
31-28	R/W	0	unused
27-25	R/W	0	Sd_emmc_B_CLK_SEL: 0:cts_oscin_clk 1:fclk_div2 2:fclk_div3 3:fclk_div5 4:fclk_div7 5:mp2_clk_out 6:mp3_clk_out 7:gp0_pll_clk
24			Reserved
23	R/W	1	Sd_emmc_B_CLK_EN:
22-16	R/W	0	Sd_emmc_B_CLK_DIV
15-12	R/W	0	reseverd
11-9	R/W	0	Sd_emmc_A_CLK_SEL: 0:cts_oscin_clk 1:fclk_div2 2:fclk_div3 3:fclk_div5 4:fclk_div7 5:mp2_clk_out 6:mp3_clk_out 7:gp0_pll_clk
8			Reserved
7	R/W	1	Sd_emmc_A_CLK_EN:
6-0	R/W	0	Sd_emmc_A_CLK_DIV

Table 7-139 HHI\_HEVC Encoder\_CLK\_CNTL 0x9A

Bit(s)	R/W	Default	Description
27:25	R/W	0	HEVC Encoder_cclk clk_sel; 0:oscin; 1:fclk_div4; 2:fclk_div3; 3:fclk_div5; 4:fclk_div7; 5:mppll2; 6:mppll3; 7:gp0pll;
24	R/W	0	HEVC Encoder_cclk clk_en
22:16	R/W	0	HEVC Encoder_cclk clk_div
11:9	R/W	0	HEVC Encoder_bclk clk_sel; 0:oscin; 1:fclk_div4; 2:fclk_div3; 3:fclk_div5; 4:fclk_div7; 5:mppll2; 6:mppll3; 7:gp0pll;
8	R/W	0	HEVC Encoder_bclk clk_en
6:0	R/W	0	HEVC Encoder_bclk clk_div

Table 7-140 HHI\_HEVC Encoder\_CLK\_CNTL2 0x9B

Bit(s)	R/W	Default	Description
11:9	R/W	0	HEVC Encoder_aclk clk_sel; 0:oscin; 1:fclk_div4; 2:fclk_div3; 3:fclk_div5; 4:fclk_div7; 5:mppll2; 6:mppll3; 7:gp0pll;
8	R/W	0	HEVC Encoder_aclk clk_en
6:0	R/W	0	HEVC Encoder_aclk clk_div

Table 7-141 HHI\_MPLL\_CNTL0 0x9E

Bit(s)	R/W	Default	Description
[21:20]	R/W	0	mppll_sys_dpll_exldo
[18:16]	R/W	0	mppll_test_c
[15:12]	R/W	0	mppll_dds_reve
[11:10]	R/W	0	mppll_dds_vc_vdd
[9:8]	R/W	0	mppll_dds_vr_fb1
[7:6]	R/W	0	mppll_dds_vr_fb2
[1]	R/W	0	mppll_dds_enldo
[0]	R/W	0	mppll_dds_ldo_rupsel

Table 7-142 HHI\_MPLL\_CNTL1 0x9F

Bit(s)	R/W	Default	Description
[31]	R/W	0	mppll_dds0_en
[30]	R/W	0	mppll_dds0_sdm_en
[29]	R/W	0	mppll_dds0_ss_en
[28:20]	R/W	0	mppll_dds0_n_in
[13:0]	R/W	0	mppll_dds0_sdm_in

**Table 7-143 HHI\_MPLL\_CNTL2 0xA0**

Bit(s)	R/W	Default	Description
[31]	R/W	0	mpll_dds0_ir_bypass
[30]	R/W	0	mpll_dds0_load
[29]	R/W	0	mpll_dds0_lp_en
[28]	R/W	0	mpll_dds0_modesel
[20:16]	R/W	0	mpll_dds0_f_set
[15:12]	R/W	0	mpll_dds0_ir_byin
[10:8]	R/W	0	mpll_dds0_p_set
[7:4]	R/W	0	mpll_dds0_vref_cf
[3:0]	R/W	0	mpll_dds0_vref_cs

**Table 7-144 HHI\_MPLL\_CNTL3 0xA1**

Bit(s)	R/W	Default	Description
[31]	R/W	0	mpll_dds1_en
[30]	R/W	0	mpll_dds1_sdm_en
[29]	R/W	0	mpll_dds1_ss_en
[28:20]	R/W	0	mpll_dds1_n_in
[13:0]	R/W	0	mpll_dds1_sdm_in

**Table 7-145 HHI\_MPLL\_CNTL4 0xA2**

Bit(s)	R/W	Default	Description
[31]	R/W	0	mpll_dds1_ir_bypass
[30]	R/W	0	mpll_dds1_load
[29]	R/W	0	mpll_dds1_lp_en
[28]	R/W	0	mpll_dds1_modesel
[20:16]	R/W	0	mpll_dds1_f_set
[15:12]	R/W	0	mpll_dds1_ir_byin
[10:8]	R/W	0	mpll_dds1_p_set
[7:4]	R/W	0	mpll_dds1_vref_cf
[3:0]	R/W	0	mpll_dds1_vref_cs

**Table 7-146 HHI\_MPLL\_CNTL5 0xA3**

Bit(s)	R/W	Default	Description
[31]	R/W	0	mpll_dds2_en
[30]	R/W	0	mpll_dds2_sdm_en
[29]	R/W	0	mpll_dds2_ss_en
[28:20]	R/W	0	mpll_dds2_n_in
[13:0]	R/W	0	mpll_dds2_sdm_in

**Table 7-147 HHI\_MPLL\_CNTL6 0xA4**

Bit(s)	R/W	Default	Description
[31]	R/W	0	mpll_dds2_ir_bypass
[30]	R/W	0	mpll_dds2_load
[29]	R/W	0	mpll_dds2_lp_en
[28]	R/W	0	mpll_dds2_modesel
[20:16]	R/W	0	mpll_dds2_f_set
[15:12]	R/W	0	mpll_dds2_ir_byin
[10:8]	R/W	0	mpll_dds2_p_set
[7:4]	R/W	0	mpll_dds2_vref_cf
[3:0]	R/W	0	mpll_dds2_vref_cs

**Table 7-148 HHI\_MPLL\_CNTL7 0xA5**

Bit(s)	R/W	Default	Description
[31]	R/W	0	mpll_dds3_en
[30]	R/W	0	mpll_dds3_sdm_en
[29]	R/W	0	mpll_dds3_ss_en
[28:20]	R/W	0	mpll_dds3_n_in
[13:0]	R/W	0	mpll_dds3_sdm_in

**Table 7-149 HHI\_MPLL\_CNTL8 0xA6**

Bit(s)	R/W	Default	Description
[31]	R/W	0	mpll_dds3_ir_bypass
[30]	R/W	0	mpll_dds3_load
[29]	R/W	0	mpll_dds3_lp_en
[28]	R/W	0	mpll_dds3_modesel
[20:16]	R/W	0	mpll_dds3_f_set
[15:12]	R/W	0	mpll_dds3_ir_byin

Bit(s)	R/W	Default	Description
[10:8]	R/W	0	mppll_dds3_p_set
[7:4]	R/W	0	mppll_dds3_vref_cf
[3:0]	R/W	0	mppll_dds3_vref_cs

Table 7-150 HHI\_MPLL\_STS 0xA7

Bit(s)	R/W	Default	Description
[28]	R	0	mppll_dds0_ir_done
[27:24]	R	0	mppll_dds0_ir_out
[20]	R	0	mppll_dds1_ir_done
[19:16]	R	0	mppll_dds1_ir_out
[12]	R	0	mppll_dds2_ir_done
[11:8]	R	0	mppll_dds2_ir_out
[4]	R	0	mppll_dds3_ir_done
[3:0]	R	0	mppll_dds3_ir_out

Table 7-151 HHI\_FIX\_PLL\_CNTL0 0xA8

Bit(s)	R/W	Default	Description
[31]	R	0	fix_dppll_lock
[30]	R	0	fix_dppll_lock_a
[29]	R/W	1	fix_dppll_reset
[28]	R/W	0	fix_dppll_en
[17:16]	R/W	0	fix_dppll_od
[14:10]	R/W	0	fix_dppll_N
[7:0]	R/W	0	fix_dppll_M

Table 7-152 HHI\_FIX\_PLL\_CNTL1 0xA9

Bit(s)	R/W	Default	Description
[25]	R/W	0	fix_dppll_div2p5_en
[24:20]	R/W	0	fixppll_dppll_clken
[18:0]	R/W	0	fix_dppll_frac

Table 7-153 HHI\_FIX\_PLL\_CNTL2 0xAA

Bit(s)	R/W	Default	Description
[22:20]	R/W	0	fix_dppll_fref_sel
[17:16]	R/W	0	fix_dppll_os_ssc

Bit(s)	R/W	Default	Description
[15:12]	R/W	0	fix_dpll_ssc_str_m
[8]	R/W	0	fix_dpll_ssc_en
[7:4]	R/W	0	fix_dpll_ssc_dep_sel
[1:0]	R/W	0	fix_dpll_ss_mode

Table 7-154 HHI\_FIX\_PLL\_CNTL3 0xAB

Bit(s)	R/W	Default	Description
31	R/W	0	fix_dpll_afc_bypass
30	R/W	0	fix_dpll_afc_clk_sel
29	R/W	0	fix_dpll_code_new
28	R/W	0	fix_dpll_dco_m_en
27	R/W	0	fix_dpll_dco_sdm_en
25	R/W	0	fix_dpll_div_mode
24	R/W	0	fix_dpll_fast_lock
23	R/W	0	fix_dpll_fb_pre_div
22	R/W	0	fix_dpll_filter_mode
21	R/W	0	fix_dpll_fix_en
20	R/W	0	fix_dpll_freq_shift_en
19	R/W	0	fix_dpll_load
18	R/W	0	fix_dpll_load_en
17	R/W	0	fix_dpll_lock_f
16	R/W	0	fix_dpll_pulse_width_en
15	R/W	0	fix_dpll_sdmnc_en
14	R/W	0	fix_dpll_sdmnc_mode
13	R/W	0	fix_dpll_sdmnc_range
12	R/W	0	fix_dpll_tdc_en
11	R/W	0	fix_dpll_tdc_mode_sel
10	R/W	0	fix_dpll_wait_en
7	R/W	0	fix_dpll_ssclk_sel
6	R/W	0	fix_dpll_clk_irscl
5	R/W	0	fix_dpll_clk50m_en

**Table 7-155 HHI\_FIX\_PLL\_CNTL4 0xAC**

Bit(s)	R/W	Default	Description
[31:28]	R/W	0	fix_dpll_alpha
[27:24]	R/W	0	fix_dpll_rou
[18:16]	R/W	0	fix_dpll_lambda0
[13:12]	R/W	0	fix_dpll_acq_gain
[11:8]	R/W	0	fix_dpll_filter_pvt2
[7:4]	R/W	0	fix_dpll_filter_pvt1
[1:0]	R/W	0	fix_dpll_pfd_gain

**Table 7-156 HHI\_FIX\_PLL\_CNTL5 0xAD**

Bit(s)	R/W	Default	Description
[30:28]	R/W	0	fix_dpll_adj_vco_ldo
[27:24]	R/W	0	fix_dpll_lm_w
[21:16]	R/W	0	fix_dpll_lm_s
[15:0]	R/W	0	fix_dpll_reve

**Table 7-157 HHI\_FIX\_PLL\_CNTL6 0xAE**

Bit(s)	R/W	Default	Description
[31:30]	R/W	0	fix_dpll_afc_hold_t
[29:28]	R/W	0	fix_dpll_lkw_sel
[27:26]	R/W	0	fix_dpll_dco_sdm_clk_sel
[25:24]	R/W	0	fix_dpll_afc_in
[23:22]	R/W	0	fix_dpll_afc_nt
[21:20]	R/W	0	fix_dpll_vc_in
[19:18]	R/W	0	fix_dpll_lock_long
[17:16]	R/W	0	fix_dpll_freq_shift_v
[14:12]	R/W	0	fix_dpll_data_sel
[10:8]	R/W	0	fix_dpll_sdmnc_ulms
[6:0]	R/W	0	fix_dpll_sdmnc_power

**Table 7-158 HHI\_FIX\_PLL\_STS 0xAF**

Bit(s)	R/W	Default	Description
[31]	R	0	fix_dpll_lock
[30]	R	0	fix_dpll_lock_a
[29]	R	0	fix_dpll_afc_done



Bit(s)	R/W	Default	Description
[22:16]	R	0	fix_dpll_sdmnc_monitor
[9:0]	R	0	fix_dpll_out_rsv

Table 7-159 HHI\_VDAC\_CNTL0 0xBB

Bit(s)	R/W	Default	Description
27	R/W	0	CDAC_BIAS_C
26	R/W	0	CDAC_EXT_VREF_EN
25	R/W	0	CDAC_DRIVER_ADJ
24	R/W	0	CDAC_CLK_PHASE_SEL
23~21	R/W	0	CDAC_RL_ADJ
20~16	R/W	0	CDAC_VREF_ADJ
15~8	R/W	0	CDAC_CTRL_RESV2
7~0	R/W	0	CDAC_CTRL_RESV1

Table 7-160 HHI\_VDAC\_CNTL1 0xBC

Bit(s)	R/W	Default	Description
23~16	R	0	CDAC_DIG_OUT_RESV
15~4	R	0	Reserved
3	R/W	0	Cdac_pwd
2~0	R/W	0	CDAC_GSW

Table 7-161 HHI\_SYS\_PLL\_CNTL0 0xBD

Bit(s)	R/W	Default	Description
[31]	R	0	sys_dpll_lock
[30]	R	0	sys_dpll_lock_a
[29]	R/W	1	sys_dpll_reset
[28]	R/W	0	sys_dpll_en
[18:16]	R/W	0	sys_dpll_od
[14:10]	R/W	0	sys_dpll_N
[7:0]	R/W	0	sys_dpll_M

Table 7-162 HHI\_SYS\_PLL\_CNTL1 0xBE

Bit(s)	R/W	Default	Description
[18:0]	R/W	0	sys_dpll_frac

Table 7-163 HHI\_SYS\_PLL\_CNTL2 0xBF

Bit(s)	R/W	Default	Description
[22:20]	R/W	0x0	sys_dpll_fref_sel
[17:16]	R/W	0x0	sys_dpll_os_ssc
[15:12]	R/W	0x0	sys_dpll_ssc_str_m
[8]	R/W	0x0	sys_dpll_ssc_en
[7:4]	R/W	0x0	sys_dpll_ssc_dep_sel
[1:0]	R/W	0x0	sys_dpll_ss_mode

Table 7-164 HHI\_SYS\_PLL\_CNTL3 0xC0

Bit(s)	R/W	Default	Description
31	R/W	0x0	sys_dpll_afc_bypass
30	R/W	0x0	sys_dpll_afc_clk_sel
29	R/W	0x0	sys_dpll_code_new
28	R/W	0x0	sys_dpll_dco_m_en
27	R/W	0x0	sys_dpll_dco_sdm_en
25	R/W	0x0	sys_dpll_div_mode
24	R/W	0x0	sys_dpll_fast_lock
23	R/W	0x0	sys_dpll_fb_pre_div
22	R/W	0x0	sys_dpll_filter_mode
21	R/W	0x0	sys_dpll_fix_en
20	R/W	0x0	sys_dpll_freq_shift_en
19	R/W	0x0	sys_dpll_load
18	R/W	0x0	sys_dpll_load_en
17	R/W	0x0	sys_dpll_lock_f
16	R/W	0x0	sys_dpll_pulse_width_en
15	R/W	0x0	sys_dpll_sdmnc_en
14	R/W	0x0	sys_dpll_sdmnc_mode
13	R/W	0x0	sys_dpll_sdmnc_range
12	R/W	0x0	sys_dpll_tdc_en
11	R/W	0x0	sys_dpll_tdc_mode_sel
10	R/W	0x0	sys_dpll_wait_en

Table 7-165 HHI\_SYS\_PLL\_CNTL4 0xC1

Bit(s)	R/W	Default	Description
[30:28]	R/W	0	sys_dpll_alpha
[26:24]	R/W	0	sys_dpll_rou
[22:20]	R/W	0	sys_dpll_lambda1
[18:16]	R/W	0	sys_dpll_lambda0
[13:12]	R/W	0	sys_dpll_acq_gain
[11:8]	R/W	0	sys_dpll_filter_pvt2
[7:4]	R/W	0	sys_dpll_filter_pvt1
[1:0]	R/W	0	sys_dpll_pfd_gain

Table 7-166 HHI\_SYS\_PLL\_CNTL5 0xC2

Bit(s)	R/W	Default	Description
[30:28]	R/W	0	sys_dpll_adj_vco_ldo
[27:24]	R/W	0	sys_dpll_lm_w
[21:16]	R/W	0	sys_dpll_lm_s
[15:0]	R/W	0	sys_dpll_reve

Table 7-167 HHI\_SYS\_PLL\_CNTL6 0xC3

Bit(s)	R/W	Default	Description
[31:30]	R/W	0	sys_dpll_afc_hold_t
[29:28]	R/W	0	sys_dpll_lkw_sel
[27:26]	R/W	0	sys_dpll_dco_sdm_clk_sel
[25:24]	R/W	0	sys_dpll_afc_in
[23:22]	R/W	0	sys_dpll_afc_nt
[21:20]	R/W	0	sys_dpll_vc_in
[19:18]	R/W	0	sys_dpll_lock_long
[17:16]	R/W	0	sys_dpll_freq_shift_v
[14:12]	R/W	0	sys_dpll_data_sel
[10:8]	R/W	0	sys_dpll_sdmnc_ulms
[6:0]	R/W	0	sys_dpll_sdmnc_power

Table 7-168 HHI\_SYS\_PLL\_STS 0xC4

Bit(s)	R/W	Default	Description
[31]	R	0	sys_dpll_lock
[30]	R	0	sys_dpll_lock_a

Bit(s)	R/W	Default	Description
[29]	R	0	sys_dppll_afc_done
[22:16]	R	0	sys_dppll_sdmnc_monitor
[9:0]	R	0	sys_dppll_out_rsv

Table 7-169 HHI\_HDMI\_PLL\_CNTL0 0xC8

Bit(s)	R/W	Default	Description
[31]	R	0	hdmi_dppll_lock
[30]	R	0	hdmi_dppll_lock_a
[29]	R/W	1	hdmi_dppll_reset
[28]	R/W	0	hdmi_dppll_en
[25:24]	R/W	0	hdmi_dppll_out_gate_ctrl
[21:20]	R/W	0	hdmi_dppll_od2
[19:16]	R/W	0	hdmi_dppll_od
[14:10]	R/W	0	hdmi_dppll_N
[7:0]	R/W	0	hdmi_dppll_M

Table 7-170 HHI\_HDMI\_PLL\_CNTL1 0xC9

Bit(s)	R/W	Default	Description
[18:0]	R/W	0	hdmi_dppll_frac

Table 7-171 HHI\_HDMI\_PLL\_CNTL2 0xCA

Bit(s)	R/W	Default	Description
[22:20]	R/W	0	hdmi_dppll_fref_sel
[17:16]	R/W	0	hdmi_dppll_os_ssc
[15:12]	R/W	0	hdmi_dppll_ssc_str_m
[8]	R/W	0	hdmi_dppll_ssc_en
[7:4]	R/W	0	hdmi_dppll_ssc_dep_sel
[1:0]	R/W	0	hdmi_dppll_ss_mode

Table 7-172 HHI\_HDMI\_PLL\_CNTL3 0xCB

Bit(s)	R/W	Default	Description
31	R/W	0	hdmi_dppll_afc_bypass
30	R/W	0	hdmi_dppll_afc_clk_sel
29	R/W	0	hdmi_dppll_code_new
28	R/W	0	hdmi_dppll_dco_m_en

Bit(s)	R/W	Default	Description
27	R/W	0	hdmi_dppll_dco_sdm_en
25	R/W	0	hdmi_dppll_div_mode
24	R/W	0	hdmi_dppll_fast_lock
23	R/W	0	hdmi_dppll_fb_pre_div
22	R/W	0	hdmi_dppll_filter_mode
21	R/W	0	hdmi_dppll_fix_en
20	R/W	0	hdmi_dppll_freq_shift_en
19	R/W	0	hdmi_dppll_load
18	R/W	0	hdmi_dppll_load_en
17	R/W	0	hdmi_dppll_lock_f
16	R/W	0	hdmi_dppll_pulse_width_en
15	R/W	0	hdmi_dppll_sdmnc_en
14	R/W	0	hdmi_dppll_sdmnc_mode
13	R/W	0	hdmi_dppll_sdmnc_range
12	R/W	0	hdmi_dppll_tdc_en
11	R/W	0	hdmi_dppll_tdc_mode_sel
10	R/W	0	hdmi_dppll_wait_en

Table 7-173 HHI\_HDMI\_PLL\_CNTL4 0xCC

Bit(s)	R/W	Default	Description
[30:28]	R/W	0	hdmi_dppll_alpha
[26:24]	R/W	0	hdmi_dppll_rou
[22:20]	R/W	0	hdmi_dppll_lambda1
[18:16]	R/W	0	hdmi_dppll_lambda0
[13:12]	R/W	0	hdmi_dppll_acq_gain
[11:8]	R/W	0	hdmi_dppll_filter_pvt2
[7:4]	R/W	0	hdmi_dppll_filter_pvt1
[1:0]	R/W	0	hdmi_dppll_pfd_gain

Table 7-174 HHI\_HDMI\_PLL\_CNTL5 0xCD

Bit(s)	R/W	Default	Description
[30:28]	R/W	0	hdmi_dppll_adj_vco_ldo
[27:24]	R/W	0	hdmi_dppll_lm_w
[21:16]	R/W	0	hdmi_dppll_lm_s
[15:0]	R/W	0	hdmi_dppll_reve

Table 7-175 HHI\_HDMI\_PLL\_CNTL6 0xCE

Bit(s)	R/W	Default	Description
[31:30]	R/W	0	hdmi_dppll_afc_hold_t
[29:28]	R/W	0	hdmi_dppll_lkw_sel
[27:26]	R/W	0	hdmi_dppll_dco_sdm_clk_sel
[25:24]	R/W	0	hdmi_dppll_afc_in
[23:22]	R/W	0	hdmi_dppll_afc_nt
[21:20]	R/W	0	hdmi_dppll_vc_in
[19:18]	R/W	0	hdmi_dppll_lock_long
[17:16]	R/W	0	hdmi_dppll_freq_shift_v
[14:12]	R/W	0	hdmi_dppll_data_sel
[10:8]	R/W	0	hdmi_dppll_sdmnc_ulms
[6:0]	R/W	0	hdmi_dppll_sdmnc_power

Table 7-176 HHI\_HDMI\_PLL\_STS 0xCF

Bit(s)	R/W	Default	Description
[31]	R	0	hdmi_dppll_lock
[30]	R	0	hdmi_dppll_lock_a
[29]	R	0	hdmi_dppll_afc_done
[22:16]	R	0	hdmi_dppll_sdmnc_monitor
[9:0]	R	0	hdmi_dppll_out_rsv

Table 7-177 HHI\_VID\_LOCK\_CLK\_CNTL 0xF2

Bit(s)	R/W	Default	Description
31~10	R/W	0	reserved
9-8	R/W	0	Clk_sel: 0:cts_oscclk_clk 1:cts_encl_clk 2:cts_enci_clk 3:cts_encp_clk
7	R/W	0	Clk_en
6-0	R/W	0	Clk_div

Table 7-178 HHI\_AXI\_PIPEL\_CNTL 0xF4

Bit(s)	R/W	Default	Description
31	R	-	MALI DMC Pipeline control: CHAN_IDLE
30	R/W	1	MALI DMC Pipeline control: REQ_EN
29	R/W	1	MALI DMC Pipeline control: AUTO_GCLK_EN

Bit(s)	R/W	Default	Description
28	R/W	0	MALI DMC Pipeline control: DISABLE_GCLK
27	R	-	HEVCF DMC Pipeline control: CHAN_IDLE
26	R/W	1	HEVCF DMC Pipeline control: REQ_EN
25	R/W	1	HEVCF DMC Pipeline control: AUTO_GCLK_EN
24	R/W	0	HEVCF DMC Pipeline control: DISABLE_GCLK
23	R	-	HEVCB DMC Pipeline control: CHAN_IDLE
22	R/W	1	HEVCB DMC Pipeline control: REQ_EN
21	R/W	1	HEVCB DMC Pipeline control: AUTO_GCLK_EN
20	R/W	0	HEVCB DMC Pipeline control: DISABLE_GCLK
15	R	-	VPU2 DMC Pipeline control: CHAN_IDLE
14	R/W	1	VPU2 DMC Pipeline control: REQ_EN
13	R/W	1	VPU2 DMC Pipeline control: AUTO_GCLK_EN
12	R/W	0	VPU2 DMC Pipeline control: DISABLE_GCLK
11	R	-	VPU1 DMC Pipeline control: CHAN_IDLE
10	R/W	1	VPU1 DMC Pipeline control: REQ_EN
9	R/W	1	VPU1 DMC Pipeline control: AUTO_GCLK_EN
8	R/W	0	VPU1 DMC Pipeline control: DISABLE_GCLK
7	R	-	VPU0 DMC Pipeline control: CHAN_IDLE
6	R/W	1	VPU0 DMC Pipeline control: REQ_EN
5	R/W	1	VPU0 DMC Pipeline control: AUTO_GCLK_EN
4	R/W	0	VPU0 DMC Pipeline control: DISABLE_GCLK
3	R	-	HCODEC DMC Pipeline control: CHAN_IDLE
2	R/W	1	HCODEC DMC Pipeline control: REQ_EN
1	R/W	1	HCODEC DMC Pipeline control: AUTO_GCLK_EN
0	R/W	0	HCODEC DMC Pipeline control: DISABLE_GCLK

Table 7-179 HHI\_BT656\_CLK\_CNTL 0xF5

Bit(s)	R/W	Default	Description
10-9	R/W	0	Bt656_1_clk_sel 0:fclk_div2 1:fclk_div3 2:fclk_div5 3:fclk_div7
8	R/W	0	Reserved
7	R/W	0	Bt656_1_clk_en
6-0	R/W	0	Bt656_1_clk_div

Table 7-180 HHI\_CDAC\_CLK\_CNTL 0xF6

Bit(s)	R/W	Default	Description
20	R/W	0	vdac_clk_c clk_en
17:16	R/W	0	vdac_clk_c clk_sel 0:osc; 1:fclk_div5;
15:0	R/W	0	vdac_clk_c: clk_div

Table 7-181 HHI\_SPICC\_CLK\_CNTL 0xF7

Bit(s)	R/W	Default	Description
25:23	R/W	0	spicc_1_clk clk_sel 0:osc; 1:clk81; 2:fclk_div4; 3:fclk_div3; 4:fclk_div2; 5:fclk_div5; 6:fclk_div7; 7:gp0_pll;
22	R/W	0	spicc_1_clk clk_en
21:16	R/W	0	spicc_1_clk clk_div
9:7	R/W	0	spicc_0_clk clk_sel 0:osc; 1:clk81; 2:fclk_div4; 3:fclk_div3; 4:fclk_div2; 5:fclk_div5; 6:fclk_div7; 7:gp0_pll;
6	R/W	0	spicc_0_clk clk_en
5:0	R/W	0	spicc_0_clk clk_div

Table 7-182 HHI\_AXI\_PIPEL\_CNTL1 0xFb

Bit(s)	R/W	Default	Description
11	R	-	HEVC Encoder DMC Pipeline control: CHAN_IDLE
10	R/W	1	HEVC Encoder DMC Pipeline control: REQ_EN
9	R/W	1	HEVC Encoder DMC Pipeline control: AUTO_GCLK_EN
8	R/W	0	HEVC Encoder DMC Pipeline control: DISABLE_GCLK
7	R	-	VDEC DMC Pipeline control: CHAN_IDLE
6	R/W	1	VDEC DMC Pipeline control: REQ_EN
5	R/W	1	VDEC DMC Pipeline control: AUTO_GCLK_EN
4	R/W	0	VDEC DMC Pipeline control: DISABLE_GCLK
3	R	-	NN DMC Pipeline control: CHAN_IDLE
2	R/W	1	NN DMC Pipeline control: REQ_EN
1	R/W	1	NN DMC Pipeline control: AUTO_GCLK_EN
0	R/W	0	NN DMC Pipeline control: DISABLE_GCLK
7	R	-	VDEC DMC Pipeline control: CHAN_IDLE
6	R/W	1	VDEC DMC Pipeline control: REQ_EN
5	R/W	1	VDEC DMC Pipeline control: AUTO_GCLK_EN
4	R/W	0	VDEC DMC Pipeline control: DISABLE_GCLK
3	R	-	NN DMC Pipeline control: CHAN_IDLE



Bit(s)	R/W	Default	Description
2	R/W	1	NN DMC Pipeline control: REQ_EN
1	R/W	1	NN DMC Pipeline control: AUTO_GCLK_EN
0	R/W	0	NN DMC Pipeline control: DISABLE_GCLK

## 7.8 Reset

### 7.8.1 Overview

The following figure shows the reset design of the SoC.

- Each reset includes 3 control registers: reg\_reset, reg\_reset\_level, and reg\_reset\_mask.
- When write “1” to reg\_reset, it will generate a signal: reset\_pulse.
- Most of module’s reset is negative, so reset\_pulse will invert to reset\_pulse\_n.
- The usage of reg\_reset\_level is hold reset\_pulse\_n to “0”.
- The usage of reg\_reset\_mask is hold reset\_pulse\_n to “1”.
- AO module has special soft reset control.
- A55 has special soft reset control.

Figure 7-23 Reset Design

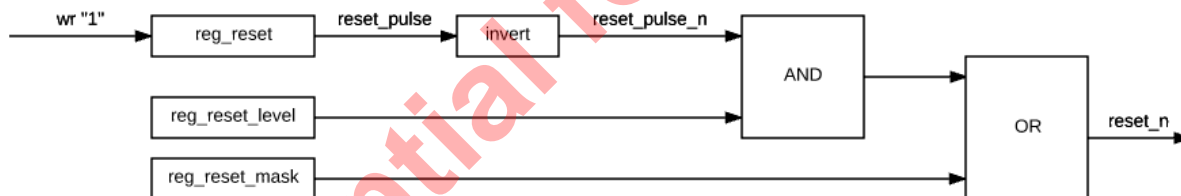

T02FC09

### 7.8.2 Register Description

#### 7.8.2.1 EE Reset

Base\_address: 0xFFD0\_1000

Each register final address = base\_address + address \* 4

Table 7-183 RESET0\_REGISTER: 0xFFD01004

Bit(s)	R/W	Default	Description
31-27	R/W	0	Reserved
26	R/W	0	vcbus_clk81
25	R/W	0	ahb_data

Bit(s)	R/W	Default	Description
24	R/W	0	ahb_cntl
23	R/W	0	cbus_capb3
22	R/W	0	-
21	R/W	0	dos_capb3
20	R/W	0	mali_capb3
19	R/W	0	hdmitx_capb3
18	R/W	0	-
17	R/W	0	decode_capb3
16	R/W	0	gic
15	R/W	0	pcie_apb
14	R/W	0	pcie_phy
13	R/W	0	vcbus
12	R/W	0	pcie_ctrl_A
11	R/W	0	assist
10	R/W	0	venc
9	R/W	0	-
8	R/W	0	-
7	R/W	0	vid_pll_div
6	R/W	0	afifo
5	R/W	0	viu
4	R/W	0	-
3	R/W	0	-
2	R/W	0	dos
1	R/W	0	-
0	R/W	0	hiu

Table 7-184 RESET1\_REGISTER: 0xFFD01008

Bit(s)	R/W	Default	Description
31-30	R/W	0	Reserved
29	R/W	0	Audio codec
28:18	R/W	0	Reserved
17	R/W	0	u2phy21
16	R/W	0	u2phy20
15	R/W	0	Reserved
14	R/W	0	sd_emmcC
13	R/W	0	sd_emmcB
12	R/W	0	sd_emmcA

Bit(s)	R/W	Default	Description
11	R/W	0	eth
10	R/W	0	isa
9	R/W	0	-
8	R/W	0	parser
7	R/W	0	-
6	R/W	0	ahb_sram
5	R/W	0	bt656
4	R/W	0	-
3	R/W	0	ddr
2	R/W	0	usb
1	R/W	0	demux
0	R/W	0	-

Table 7-185 RESET2\_REGISTER: 0xFFD0100C

Bit(s)	R/W	Default	Description
15	R/W	0	hdmitx
14	R/W	0	mali
13	R/W	0	NN_pipeline1
12	R/W	0	NN
11	R/W	0	NN_pipeline0
10	R/W	0	parser_top
9	R/W	0	parser_ctl
8	R/W	0	parser_fetch
7	R/W	0	parser_reg
6	R/W	0	ge2d
5	R/W	0	-
4	R/W	0	-
3	R/W	0	-
2	R/W	0	hdmi_tx_pphy
1	R/W	0	audio
0	R/W	0	

Table 7-186 RESET3\_REGISTER: 0xFFD01010

Bit(s)	R/W	Default	Description
15	R/W	0	demux_2
14	R/W	0	demux_1

Bit(s)	R/W	Default	Description
13	R/W	0	demux_0
12	R/W	0	demux_s2p_1
11	R/W	0	demux_s2p_0
10	R/W	0	demux_des_pl
9	R/W	0	demux_top
8	R/W	0	parser1_ctl
7	R/W	0	parser1_fetch
6	R/W	0	parser1_reg
5	R/W	0	parser1
4	R/W	0	parser1_top
3	R/W	0	-
2	R/W	0	-
1	R/W	0	-
0	R/W	0	demux_s2p_2

Table 7-187 RESET4\_REGISTER: 0xFFD01014

Bit(s)	R/W	Default	Description
15	R/W	0	i2c_m2
14	R/W	0	i2c_m1
13	R/W	0	vencl
12	R/W	0	vdi6
11	R/W	0	-
10	R/W	0	-
9	R/W	0	vdac
8	R/W	0	-
7	R/W	0	vencp
6	R/W	0	venci
5	R/W	0	rdma
4	R/W	0	-
3	R/W	0	-
2	R/W	0	-
1	R/W	0	-
0	R/W	0	-

Table 7-188 RESET6\_REGISTER: 0xFFD0101c

Bit(s)	R/W	Default	Description
15	R/W	0	mali_pipeline
14	R/W	0	i2c_m3
13	R/W	0	spifc
12	R/W	0	async1
11	R/W	0	async0
10	R/W	0	uart1_2
9	R/W	0	uart0
8	R/W	0	ts_cpu
7	R/W	0	stream
6	R/W	0	spicc1
5	R/W	0	ts_pll
4	R/W	0	i2c_m0
3	R/W	0	sana_3
2	R/W	0	sc
1	R/W	0	spicc0
0	R/W	0	gen

Table 7-189 RESET7\_REGISTER: 0xFFD01020

Bit(s)	R/W	Default	Description
15	R/W	0	vdec_pipl
14	R/W	0	async_fifo3
13	R/W	0	hevcf_dmc_pipl
12	R/W	0	HEVC Encoder_dmc_pipl
11	R/W	0	hcodec_dmc_pipl
10	R/W	0	ge2d_dmc_pipl
9	R/W	0	dmc_vpu_pipl
8	R/W	0	nic_dmc_pipl
7	R/W	0	vid_lock
6	R/W	0	mali_dmc_pipl
5	R/W	0	device_mmc_arb
4	R/W	0	ts_gpu
3	R/W	0	usb_ddr3
2	R/W	0	usb_ddr2

Bit(s)	R/W	Default	Description
1	R/W	0	usb_ddr1
0	R/W	0	usb_ddr0

**RESET0\_MASK 0xFFD01040**

The Bits of this register correspond to the RESET[n] REGISTERS above. If a bit is set in this register, then when the watchdog timer fires, that particular module will NOT be reset.

**RESET1\_MASK 0xFFD01044**

The Bits of this register correspond to the RESET[n] REGISTERS above. If a bit is set in this register, then when the watchdog timer fires, that particular module will NOT be reset.

**RESET2\_MASK 0xFFD01048**

The Bits of this register correspond to the RESET[n] REGISTERS above. If a bit is set in this register, then when the watchdog timer fires, that particular module will NOT be reset.

**RESET3\_MASK 0xFFD0104c**

The Bits of this register correspond to the RESET[n] REGISTERS above. If a bit is set in this register, then when the watchdog timer fires, that particular module will NOT be reset.

**RESET4\_MASK 0xFFD01050**

The Bits of this register correspond to the RESET[n] REGISTERS above. If a bit is set in this register, then when the watchdog timer fires, that particular module will NOT be reset.

**RESET6\_MASK 0xFFD01058**

The Bits of this register correspond to the RESET[n] REGISTERS above. If a bit is set in this register, then when the watchdog timer fires, that particular module will NOT be reset.

**RESET7\_MASK 0xFFD0105c**

The Bits of this register correspond to the RESET[n] REGISTERS above. If a bit is set in this register, then when the watchdog timer fires, that particular module will NOT be reset.

**RESET0\_LEVEL 0xFFD01080**

The bits of this register correspond to the RESET[n] REGISTERS above. The default of this register is 0xFFFFFFFF. Setting any bit to 0, forces the corresponding RESET LOW. This registers allows the software to "Hold" a reset LOW (in a reset condition).

**RESET1\_LEVEL 0xFFD01084**

The bits of this register correspond to the RESET[n] REGISTERS above. The default of this register is 0xFFFFFFFF. Setting any bit to 0, forces the corresponding RESET LOW. This registers allows the software to "Hold" a reset LOW (in a reset condition).

**RESET2\_LEVEL 0xFFD01088**

The bits of this register correspond to the RESET[n] REGISTERS above. The default of this register is 0xFFFFFFFF. Setting any bit to 0, forces the corresponding RESET LOW. This registers allows the software to "Hold" a reset LOW (in a reset condition).

**RESET3\_LEVEL 0xFFD0108c**

The bits of this register correspond to the RESET[n] REGISTERS above. The default of this register is 0xFFFFFFFF. Setting any bit to 0, forces the corresponding RESET LOW. This registers allows the software to "Hold" a reset LOW (in a reset condition).

**RESET4\_LEVEL 0xFFD01090**

The bits of this register correspond to the RESET[n] REGISTERS above. The default of this register is 0xFFFFFFFF. Setting any bit to 0, forces the corresponding RESET LOW. This registers allows the software to “Hold” a reset LOW (in a reset condition).

#### RESET6\_LEVEL 0xFFD01098

The bits of this register correspond to the RESET[n] REGISTERS above. The default of this register is 0xFFFFFFFF. Setting any bit to 0, forces the corresponding RESET LOW. This registers allows the software to “Hold” a reset LOW (in a reset condition).

#### RESET7\_LEVEL 0xFFD0109c

The bits of this register correspond to the RESET[n] REGISTERS above. The default of this register is 0xFFFFFFFF. Setting any bit to 0, forces the corresponding RESET LOW. This registers allows the software to “Hold” a reset LOW (in a reset condition).

### 7.8.2.2 AO Soft Rest

Base\_address: 0xFF80\_0040

Each register final address = base\_address + address \* 4

**Table 7-190 AO Soft Rest 0xFF800044**

Bit(s)	R/W	Default	Description
31-24	R/W	0	Reserved
23	R/W	0	ir_out
22	R/W	0	uart2
21	R/W	0	Reserved
20	R/W	0	sar_adc
19	R/W	0	i2c_s
18	R/W	0	i2c_m
17	R/W	0	uart
16	R/W	0	ir_in
15-0	R/W	0	Reserved

### 7.8.2.3 SEC Reset

**Table 7-191 reset0 0xFF64E000**

Bit(s)	R/W	Default	Description
6	R/W	0	ao_mailbox
5	R/W	0	ao
4	R/W	0	dma
3	R/W	0	Reserved
2	R/W	0	am_ring_osc
1	R/W	0	m4_cpu
0	R/W	0	ao_cpu

Table 7-192 reset1 0xFF64E004

Bit(s)	R/W	Default	Description
20	R/W	0	cpu_periphs
19	R/W	0	cpu_gic
18	R/W	0	-
17	R/W	0	dsu
16	R/W	0	dsu_po
15	R/W	0	sys_core3
14	R/W	0	sys_core2
13	R/W	0	sys_core1
12	R/W	0	sys_core0
11	R/W	0	sys_core3
10	R/W	0	sys_core2
9	R/W	0	sys_core1
8	R/W	0	sys_core0
7	R/W	0	sys_pll_div
6	R/W	0	presetrn_sys_cpu_capb3
5	R/W	0	rom_boot
4	R/W	0	syscpu_axi
3	R/W	0	syscpu_l2
2	R/W	0	syscpu_preset
1	R/W	0	syscpu_mbist
0	R/W	0	sys_cpu_cpu

**RESET0\_SEC\_LEVEL 0xFF64E040**

The bits of this register correspond to the RESET[n]\_SEC REGISTERS above. The default of this register is 0xFFFFFFFF. Setting any bit to 0, forces the corresponding RESET LOW. This registers allows the software to “Hold” a reset LOW (in a reset condition).

**RESET1\_SEC\_LEVEL 0xFF64E044**

The bits of this register correspond to the RESET[n]\_SEC REGISTERS above. The default of this register is 0xFFFFFFFF. Setting any bit to 0, forces the corresponding RESET LOW. This registers allows the software to “Hold” a reset LOW (in a reset condition).

**RESET0\_SEC\_MASK 0xFF64E080**

The Bits of this register correspond to the RESET[n]\_SEC REGISTERS above. If a bit is set in this register, then when the watchdog timer fires, that particular module will NOT be reset.

**RESET1\_SEC\_MASK 0xFF64E084**

The Bits of this register correspond to the RESET[n]\_SEC REGISTERS above. If a bit is set in this register, then when the watchdog timer fires, that particular module will NOT be reset.



## 7.8.2.4 A55 Soft Reset

Table 7-193 a55\_soft\_reset 0xFF63C160

Bit(s)	R/W	Default	Description
16	R/W	0	Cpu_axi_reset
15	R/W	0	-
14	R/W	0	nPERIPHRESET
13	R/W	0	nGICRESET
12	R/W	0	-
11	R/W	0	nPERSETDBG
10	R/W	0	syscpu_axi
9	R/W	0	syscpu_preset
8	R/W	0	syscpu_l2
7	R/W	0	sys_core3
6	R/W	0	sys_core2
5	R/W	0	sys_core1
4	R/W	0	sys_core0
3	R/W	0	sys_core3_por
2	R/W	0	sys_core2_por
1	R/W	0	sys_core1_por
0	R/W	0	sys_core0_por

## 7.9 GPIO

### 7.9.1 Overview

The SOC has a number of multi-function digital I/O pads that can be multiplexed to a number of internal resources (e.g. PWM generators, SDIO controllers). When a digital I/O is not being used for any specific purpose, it is converted to a general purpose GPIO pin. A GPIO pin can be statically set to high/low logical levels. The structure of a GPIO is given below.

Figure 7-24 GPIO Structure

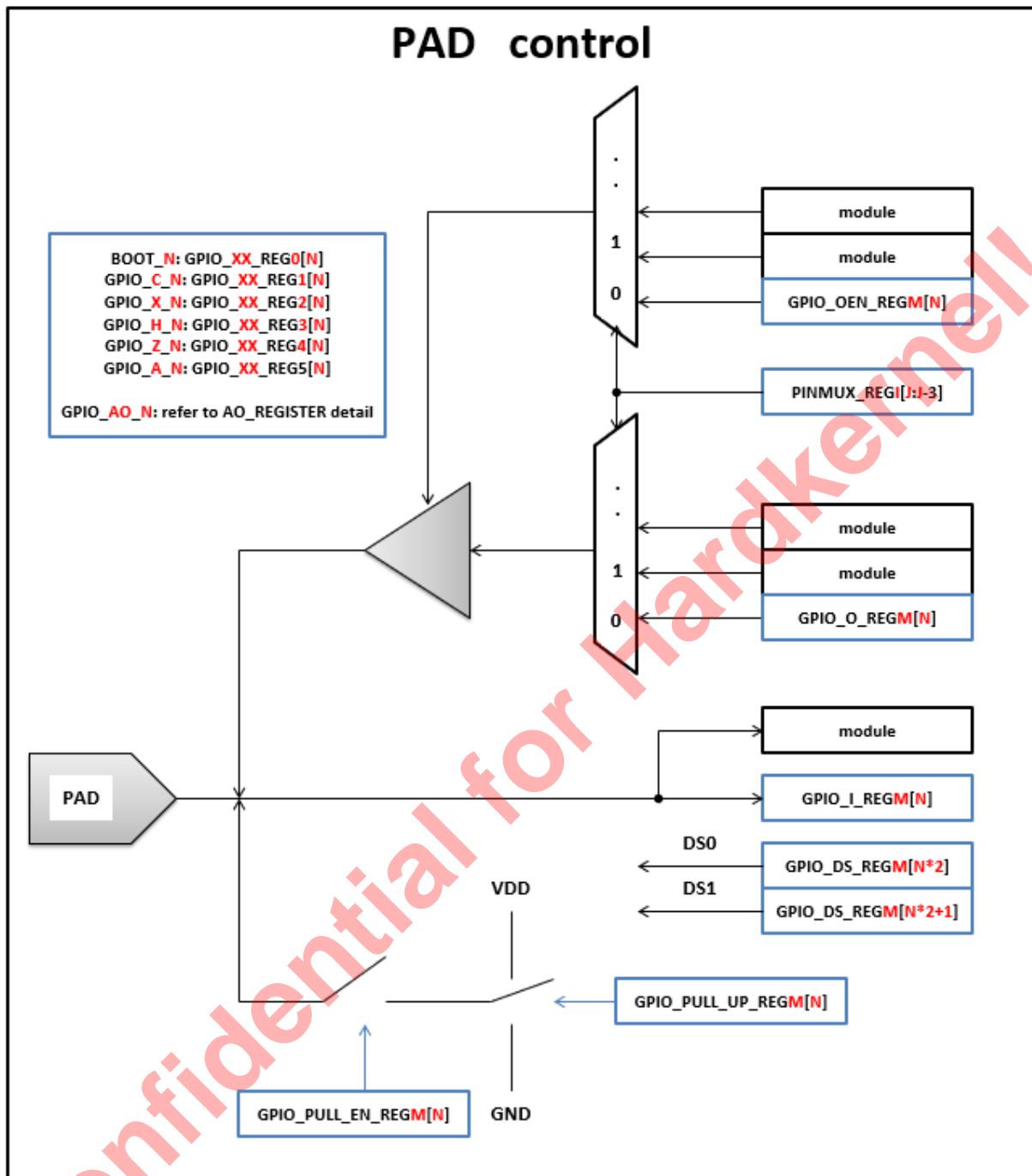

Each GPIO pad has 6 related registers, among which:

- GPIO\_O\_REG is used to control the output of the pad;
- GPIO\_I\_REG is used to store the input value of the pad;
- GPIO\_O\_EN\_REG is used to enable GPIO output function;
- PINMUX\_REG is used to define the function;
- GPIO\_PULL\_EN\_REG is used to enable the pull-up function of GPIO pad;
- GPIO\_PULL\_UP\_REG is used to control GPIO PAD to be whether pull-up or pull-down;
- For AO GPIO pads, refer to AO GPIO registers.

There are OD pins that can not be used as output, with different structure, shown as following.

Figure 7-25 OD Pad Structure

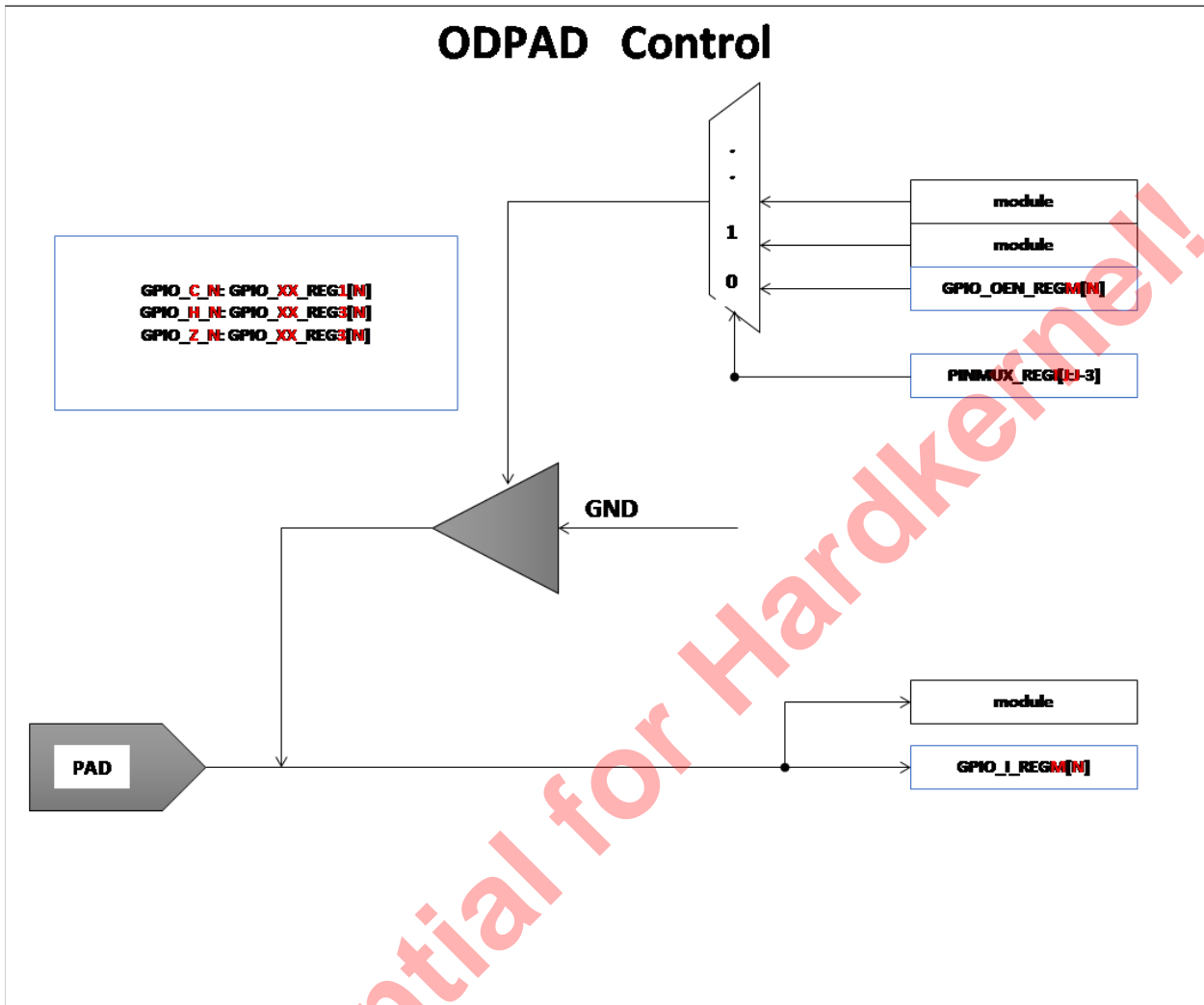

### 7.9.2 GPIO Multiplex Function

The GPIO multiplex functions are shown in the sections below, where the `RegNN[MM]` corresponds to CBUS registers defined in the following table. The base address is `0xff634400` for `PERIPHERS_PIN_MUX_X`, `PREG_PAD_GPIO_EN_N`, `PREG_PAD_GPIO_O`, `PREG_PAD_GPIO_I`, `PAD_PULL_UP_EN_REG`, `PAD_PULL_UP_REG`; and `0xff800000` for `AO_RTI_PIN_MUX_REG`, the final address is calculated as: `final address = base address + offset*4`.

Table 7-194 Pin Mux Registers

Pin Mux Registers	Offset	Reset by Watchdog
AO_GPIO_I	0x0a	Yes
AO_GPIO_O	0x0d	Yes
AO_GPIO_O_EN_N	0x09	Yes
AO_RTI_PULL_UP_REG	0x0b	Yes

Pin Mux Registers	Offset	Reset by Watchdog
AO_RTI_PULL_UP_EN_REG	0x0c	Yes
AO_PAD_DS_A	0x07	Yes
AO_PAD_DS_B	0x08	Yes
AO_RTI_PINMUX_REG0	0x05	Yes
AO_RTI_PINMUX_REG1	0x06	Yes
PERIPHS_PIN_MUX_0	0xb0	Yes
PERIPHS_PIN_MUX_1	0xb1	Yes
PERIPHS_PIN_MUX_2	0xb2	Yes
PERIPHS_PIN_MUX_3	0xb3	Yes
PERIPHS_PIN_MUX_4	0xb4	Yes
PERIPHS_PIN_MUX_5	0xb5	Yes
PERIPHS_PIN_MUX_6	0xb6	Yes
PERIPHS_PIN_MUX_7	0xb7	Yes
PERIPHS_PIN_MUX_8	0xb8	Yes
PERIPHS_PIN_MUX_9	0xb9	Yes
PERIPHS_PIN_MUX_A	0xba	Yes
PERIPHS_PIN_MUX_B	0xbb	Yes
PERIPHS_PIN_MUX_C	0xbc	Yes
PERIPHS_PIN_MUX_D	0xbd	Yes
PERIPHS_PIN_MUX_E	0xbe	Yes
PERIPHS_PIN_MUX_F	0xbf	Yes
PAD_DS_REG0A	0xd0	Yes
PAD_DS_REG1A	0xd1	Yes
PAD_DS_REG2A	0xd2	Yes
PAD_DS_REG2B	0xd3	Yes
PAD_DS_REG3A	0xd4	Yes
PAD_DS_REG4A	0xd5	Yes
PAD_DS_REG5A	0xd6	Yes
PAD_PULL_UP_REG0	0x3a	Yes
PAD_PULL_UP_REG1	0x3b	Yes
PAD_PULL_UP_REG2	0x3c	Yes
PAD_PULL_UP_REG3	0x3d	Yes
PAD_PULL_UP_REG4	0x3e	Yes
PAD_PULL_UP_REG5	0x3f	Yes
PAD_PULL_UP_EN_REG0	0x48	Yes

Pin Mux Registers	Offset	Reset by Watchdog
PAD_PULL_UP_EN_REG1	0x49	Yes
PAD_PULL_UP_EN_REG2	0x4a	Yes
PAD_PULL_UP_EN_REG3	0x4b	Yes
PAD_PULL_UP_EN_REG4	0x4c	Yes
PAD_PULL_UP_EN_REG5	0x4d	Yes
PREG_PAD_GPIO0_EN_N	0x10	Yes
PREG_PAD_GPIO0_O	0x11	Yes
PREG_PAD_GPIO0_I	0x12	Yes
PREG_PAD_GPIO1_EN_N	0x13	Yes
PREG_PAD_GPIO1_O	0x14	Yes
PREG_PAD_GPIO1_I	0x15	Yes
PREG_PAD_GPIO2_EN_N	0x16	Yes
PREG_PAD_GPIO2_O	0x17	Yes
PREG_PAD_GPIO2_I	0x18	Yes
PREG_PAD_GPIO3_EN_N	0x19	Yes
PREG_PAD_GPIO3_O	0x1a	Yes
PREG_PAD_GPIO3_I	0x1b	Yes
PREG_PAD_GPIO4_EN_N	0x1c	Yes
PREG_PAD_GPIO4_O	0x1d	Yes
PREG_PAD_GPIO4_I	0x1e	Yes
PREG_PAD_GPIO5_EN_N	0x20	Yes
PREG_PAD_GPIO5_O	0x21	Yes
PREG_PAD_GPIO5_I	0x22	Yes

Table 7-195 GPIOZ\_x Multi-Function Pin

Pin Name	Control Register	Control Bit	Func1	Func2	Func3	Func4	Func5	Func6	Func7
GPIOZ_0	PE-RIPHS_PIN_MUX_6	[3:0]	ETH_MDIO	BT656_A_VS	IS-O7816_CLK	I2C_EE_M0_SDA	PWM_B	I2C_EE_M1_SDA	
GPIOZ_1		[7:4]	ETH_MDC	BT656_A_HS	IS-O7816_DATA	I2C_EE_M0_SCL	PWM_C	I2C_EE_M1_SCL	
GPIOZ_2		[11:8]	ETH_RGMII_RX_CLK	PWM_D	TSIN_B_VALID	TDMC_D0	SDCAR-D_D0	TDMC_DIN0	PDM_DIN0
GPIOZ_3		[15:12]	ETH_RX_DV	BT656_A_CLK	TSIN_B_SOP	TDMC_D1	SDCAR-D_D1	TDMC_DIN1	PDM_DIN1

Pin Name	Control Register	Control Bit	Func1	Func2	Func3	Func4	Func5	Func6	Func7
GPIOZ_4		[19:16]	ETH_RXD0	BT656_A_DIN0	TSIN_B_DIN0	TDMC_D2	SDCARD_D2	TDMC_DIN2	PDM_DIN2
GPIOZ_5		[23:20]	ETH_RXD1	BT656_A_DIN1	TSIN_B_CLK	TDMC_D3	SDCARD_D3	TDMC_DIN3	PDM_DIN3
GPIOZ_6		[27:24]	ETH_RXD2_RGMII	BT656_A_DIN2	TSIN_B_FAIL	TDMC_FS	SDCARD_CLK	TDMC_SLV_FS	PDM_DCLK
GPIOZ_7		[31:28]	ETH_RXD3_RGMII	BT656_A_DIN3	TSIN_B_DIN1	TDMC_SCLK	SDCARD_CMD	TDMC_SLV_SCLK	I2C_EE_M0_SDA
GPIOZ_8	PERIPHS_PIN_MUX_7	[3:0]	ETH_RGMII_TX_CLK	BT656_A_DIN4	TSIN_B_DIN2	MCLK_1			I2C_EE_M0_SCL
GPIOZ_9		[7:4]	ETH_TXEN	BT656_A_DIN5	TSIN_B_DIN3	TDMC_D4			
GPIOZ_10		[11:8]	ETH_TXD0	BT656_A_DIN6	TSIN_B_DIN4	I2C_EE_M2_SDA	IR_REMOTE_OUT		
GPIOZ_11		[15:12]	ETH_TXD1	BT656_A_DIN7	TSIN_B_DIN5	I2C_EE_M2_SCL			
GPIOZ_12		[19:16]	ETH_TXD2_RGMII		TSIN_B_DIN6	TDMC_D5	PWM_F		
GPIOZ_13		[23:20]	ETH_TXD3_RGMII	CLK12_24	TSIN_B_DIN7		PWM_B		GEN_CLK_EE
GPIOZ_14		[27:24]	ETH_LINK_LED		I2C_EE_M2_SDA				
GPIOZ_15		[31:28]	ETH_ACT_LED		I2C_EE_M2_SCL				

Table 7-196 GPIOA\_x Multi-Function Pin

Pin Name	Control Register	Control Bit	Func1	Func2
GPIOA_14	PERIPHS_PIN_MUX_E	[27:24]	WORLD_SYNC	I2C_EE_M3_SDA
GPIOA_15		[31:28]	IR_REMOTE_INPUT	I2C_EE_M3_SCL

Table 7-197 BOOT\_x Multi-Function Pin

Pin Name	Control Register	Control Bit	Func1	Func2	Func3
BOOT_0	PERIPHS_PIN_MUX_0	[3:0]	EMMC_D0		
BOOT_1		[7:4]	EMMC_D1		
BOOT_2		[11:8]	EMMC_D2		
BOOT_3		[15:12]	EMMC_D3		NOR_HOLD

Pin Name	Control Register	Control Bit	Func1	Func2	Func3
BOOT_4		[19:16]	EMMC_D4		NOR_D
BOOT_5		[23:20]	EMMC_D5		NOR_Q
BOOT_6		[27:24]	EMMC_D6		NOR_C
BOOT_7		[31:28]	EMMC_D7		NOR_WP
BOOT_8	PERIPHS_PIN_MUX_1	[3:0]	EMMC_CLK	NAND_WEN_CLK	
BOOT_9		[7:4]		NAND_ALE	
BOOT_10		[11:8]	EMMC_CMD	NAND_CLE	
BOOT_11		[15:12]		NAND_CE0	
BOOT_12		[19:16]		NAND_REN_WR	
BOOT_13		[23:20]	EMMC_NAND_DQS		
BOOT_14		[27:24]		NAND_RB0	NOR_CS
BOOT_15		[31:28]		NAND_CE1	

Table 7-198 GPIOC\_x Multi-Function Pin

Pin Name	Control Register	Control Bit	Func1	Func2	Func3	Func4	Func5
GPIOC_0	PERIPHS_PIN_MUX_9	[3:0]	SDCARD_D0	JTAG_B_TDO		PDM_DIN0	SPI_A_MOSI
GPIOC_1		[7:4]	SDCARD_D1	JTAG_B_TDI		PDM_DIN1	SPI_A_MISO
GPIOC_2		[11:8]	SDCARD_D2	UART_AO_A_RX		PDM_DIN2	SPI_A_SS0
GPIOC_3		[15:12]	SDCARD_D3	UART_AO_A_TX		PDM_DIN3	SPI_A_SCLK
GPIOC_4		[19:16]	SDCARD_CLK	JTAG_B_CLK		PDM_DCLK	PWM_C
GPIOC_5		[23:20]	SDCARD_CMD	JTAG_B_TMS	I2C_EE_M0_SDA		ISO7816_CLK
GPIOC_6		[27:24]			I2C_EE_M0_SCL		ISO7816_DATA
GPIOC_7		[31:28]	PCIECK_REQN	WORLD_SYNC			

Table 7-199 GPIOX\_x Multi-Function Pin

Pin Name	Control Register	Control Bit	Func1	Func2	Func3	Func4	Func5	Func6	Func7
GPIOX_0	PERIPHS_PIN_MUX_3	[3:0]	SDIO_D0	PDM_DIN0	TSIN_A_DIN0		SDCARD_D_D0		
GPIOX_1		[7:4]	SDIO_D1	PDM_DIN1	TSIN_A_SOP		SDCARD_D_D1		

Pin Name	Control Register	Control Bit	Func1	Func2	Func3	Func4	Func5	Func6	Func7
GPIOX_2		[11:8]	SDIO_D2	PDM_DIN2	TSIN_A_VALID		SDCARD_D2		
GPIOX_3		[15:12]	SDIO_D3	PDM_DIN3	TSIN_A_CLK	PWM_D	SDCARD_D3		
GPIOX_4		[19:16]	SDIO_CLK	PDM_DCLK			SDCARD_CLK		
GPIOX_5		[23:20]	SDIO_CMD	MCLK_1		PWM_C	SDCARD_CMD		
GPIOX_6		[27:24]	PWM_A	UART_EE_B_TX		PWM_D			
GPIOX_7		[31:28]	PWM_F	UART_EE_B_RX		PWM_B			
GPIOX_8		PE-RIPHS_PIN_MUX_4	[3:0]	TDMA_D1	TDMA_DIN1	TSIN_B_SOP	SPI_A_MOSI	PWM_C	IS-O7816_CLK
GPIOX_9	[7:4]		TDMA_D0	TDMA_DIN0	TSIN_B_VALID	SPI_A_MISO		IS-O7816_DATA	
GPIOX_10	[11:8]		TDMA_FS	TDMA_SLV_FS	TSIN_B_DIN0	SPI_A_SS0	I2C_EE_M1_SDA		
GPIOX_11	[15:12]		TDMA_SCLK	TDMA_SLV_SCLK	TSIN_B_CLK	SPI_A_SCLK	I2C_EE_M1_SCL		
GPIOX_12	[19:16]		UART_EE_A_TX						
GPIOX_13	[23:20]		UART_EE_A_RX						
GPIOX_14	[27:24]		UART_EE_A_CTS						
GPIOX_15	[31:28]		UART_EE_A_RTS						
GPIOX_16	PE-RIPHS_PIN_MUX_5		[3:0]	PWM_E					
GPIOX_17		[7:4]	I2C_EE_M2_SDA						
GPIOX_18		[11:8]	I2C_EE_M2_SCL						
GPIOX_19		[15:12]	PWM_B	WORLD_SYNC					GEN_CLK_EE



Table 7-200 GPIOH\_x Multi-Function Pin

Pin Name	Control Register	Control Bit	Func1	Func2	Func3	Func4	Func5	Func6
GPIOH_0	PE-RIPHS_PIN_MUX_B	[3:0]	HDMITX_SDA	I2C_EE_M3_SDA				
GPIOH_1		[7:4]	HDMITX_SCL	I2C_EE_M3_SCL				
GPIOH_2		[11:8]	HDMITX_HPDI_IN	I2C_EE_M1_SDA				
GPIOH_3		[15:12]		I2C_EE_M1_SCL		AO_CEC_A	AO_CEC_B	
GPIOH_4		[19:16]	SPDIF_OUT	UART_EE_C_RTS	SPI_B_MOSI			
GPIOH_5		[23:20]	SPDIF_IN	UART_EE_C_CTS	SPI_B_MISO	PWM_F	TDMB_D3	TDMB_DIN3
GPIOH_6		[27:24]	ISO7816_CLK	UART_EE_C_RX	SPI_B_SS0	I2C_EE_M1_SDA	IR_REMOTE_OUT	
GPIOH_7		[31:28]	ISO7816_DATA	UART_EE_C_TX	SPI_B_SCLK	I2C_EE_M1_SCL	PWM_B	
GPIOH_8	PE-RIPHS_PIN_MUX_C	[3:0]						

Table 7-201 GPIOAO\_x Multi-Function Pin

Pin Name	Control Register	Control Bit	Func1	Func2	Func3	Func4	Func5	Func6	Func7
GPIOAO_0	AO_RTIPIN_MUX_REG0	[3:0]	UART_AO_A_TX						
GPIOAO_1		[7:4]	UART_AO_A_RX						
GPIOAO_2		[11:8]	I2C_AO_M0_SCL	UART_AO_B_TX	I2C_AO_S0_SCL				
GPIOAO_3		[15:12]	I2C_AO_M0_SDA	UART_AO_B_RX	I2C_AO_S0_SDA				
GPIOAO_4		[19:16]	IR_REMOTE_OUT	CLK_32K_IN	PWMA_O_C	PWMA_O_C_HI_Z	TDMB_D0	TDMB_DIN0	
GPIOAO_5		[23:20]	IR_REMOTE_INPUT		PWMA_O_D				
GPIOAO_6		[27:24]	JTAG_A_CLK		PWMA_O_C	TSIN_A_SOP	TDMB_D2	TDMB_DIN2	
GPIOAO_7		[31:28]	JTAG_A_TMS			TSIN_A_DIN0	TDMB_FS	TDMB_SLV_FS	

Pin Name	Control Register	Control Bit	Func1	Func2	Func3	Func4	Func5	Func6	Func7
GPIOA-O_8	AO_RT <sub>I</sub> _PIN-MUX_REG1	[3:0]	JTAG_A_TDI		UART_AO_B_TX	TSIN_A_CLK	TDMB_SCLK	TDMB_SLV_SCLK	
GPIOA-O_9		[7:4]	JTAG_A_TDO	IR_REMOTE_OUT	UART_AO_B_RX	TSIN_A_VALID	MCLK_0		
GPIOA-O_10		[11:8]	AO_CEC_A	AO_CEC_B	PWMA-O_D	SPDIF_OUT	TDMB_D1	TDMB_DIN1	CLK12_24
GPIOA-O_11		[15:12]		PWMA-O_A_HIZ	PWMA-O_A	GEN_CLK_EE	GEN_CLK_AO		

Table 7-202 GPIOE\_x Multi-Function Pin

Pin Name	Control Register	Control Bit	Func1	Func2	Func3	Func4
GPIOE_0	AO_RT <sub>I</sub> _PIN-MUX_REG1	[19:16]	UART_AO_A_CTS	UART_AO_B_CTS	PWMAO_B	I2C_AO_M0_SCL
GPIOE_1		[23:20]	UART_AO_A_RTS	UART_AO_B_RTS	PWMAO_D	I2C_AO_M0_SDA
GPIOE_2		[27:24]	CLK12_24	CLK25_EE	PWM_A	

### 7.9.3 Register Description

The following table shows the mapping information of GPIO I/O Registers and Nets.

Register	Offset	Net Name
PREG_PAD_GPIO0_EN_N	0x10	BOOT
PREG_PAD_GPIO0_O	0x11	
PREG_PAD_GPIO0_I	0x12	
PAD_PULL_UP_REG0	0x3a	
PAD_PULL_UP_EN_REG0	0x48	
PAD_DS_REG0A	0xd0	
PERIPHS_PIN_MUX_0	0xb0	
PERIPHS_PIN_MUX_1	0xb1	
PREG_PAD_GPIO3_EN_N	0x19	GPIOC
PREG_PAD_GPIO3_O	0x1a	
PREG_PAD_GPIO3_I	0x1b	
PAD_PULL_UP_REG3	0x3d	
PAD_PULL_UP_EN_REG3	0x4b	
PERIPHS_PIN_MUX_4	0xb4	
PERIPHS_PIN_MUX_5	0xb5	

Register	Offset	Net Name
PREG_PAD_GPIO2_EN_N	0x16	GPIOH
PREG_PAD_GPIO2_O	0x17	
PREG_PAD_GPIO2_I	0x18	
PAD_PULL_UP_REG2	0x3c	
PAD_PULL_UP_EN_REG2	0x4a	
PAD_DS_REG2A	0xd2	
PAD_DS_REG2B	0xd3	
PAD_DS_REG3A	0xd4	
PERIPHS_PIN_MUX_7	0xb7	
PERIPHS_PIN_MUX_8	0xb8	
PERIPHS_PIN_MUX_9	0xb9	
PREG_PAD_GPIO4_EN_N	0x1c	
PREG_PAD_GPIO4_O	0x1d	
PREG_PAD_GPIO4_I	0x1e	
PERIPHS_PIN_MUX_A	0xba	
PERIPHS_PIN_MUX_B	0xbb	
PREG_PAD_GPIO5_EN_N	0x20	GPIODV
PREG_PAD_GPIO5_O	0x21	
PREG_PAD_GPIO5_I	0x22	
PAD_PULL_UP_REG5	0x3f	
PAD_PULL_UP_EN_REG5	0x4d	
PAD_DS_REG5A	0xd6	
PERIPHS_PIN_MUX_C	0xbc	
PERIPHS_PIN_MUX_D	0xbd	
PAD_PULL_UP_REG1	0x3b	GPIOZ
PAD_PULL_UP_EN_REG1	0x49	
PAD_DS_REG1A	0xd1	
PERIPHS_PIN_MUX_2	0xb2	
PERIPHS_PIN_MUX_3	0xb3	
PREG_PAD_GPIO1_EN_N	0x13	
PREG_PAD_GPIO1_O	0x14	
PREG_PAD_GPIO1_I	0x15	

### 7.9.3.1 Pin MUX Registers

Table 7-203 PERIPHS\_PIN\_MUX\_0 0xb0

Bit(s)	R/W	Default	Description
[3:0]	R/W	0	pin mux select bits for BOOT_0
[7:4]	R/W	0	pin mux select bits for BOOT_1
[11:8]	R/W	0	pin mux select bits for BOOT_2
[15:12]	R/W	0	pin mux select bits for BOOT_3
[19:16]	R/W	0	pin mux select bits for BOOT_4
[23:20]	R/W	0	pin mux select bits for BOOT_5
[27:24]	R/W	0	pin mux select bits for BOOT_6
[31:28]	R/W	0	pin mux select bits for BOOT_7

Table 7-204 PERIPHS\_PIN\_MUX\_1 0xb1

Bit(s)	R/W	Default	Description
[3:0]	R/W	0	pin mux select bits for BOOT_8
[7:4]	R/W	0	pin mux select bits for BOOT_9
[11:8]	R/W	0	pin mux select bits for BOOT_10
[15:12]	R/W	0	pin mux select bits for BOOT_11
[19:16]	R/W	0	pin mux select bits for BOOT_12
[23:20]	R/W	0	pin mux select bits for BOOT_13
[27:24]	R/W	0	pin mux select bits for BOOT_14
[31:28]	R/W	0	pin mux select bits for BOOT_15

#### PERIPHS\_PIN\_MUX\_2 0xb2

Reserved.

Table 7-205 PERIPHS\_PIN\_MUX\_3 0xb3

Bit(s)	R/W	Default	Description
[3:0]	R/W	0	pin mux select bits for GPIOX_0
[7:4]	R/W	0	pin mux select bits for GPIOX_1
[11:8]	R/W	0	pin mux select bits for GPIOX_2
[15:12]	R/W	0	pin mux select bits for GPIOX_3
[19:16]	R/W	0	pin mux select bits for GPIOX_4
[23:20]	R/W	0	pin mux select bits for GPIOX_5
[27:24]	R/W	0	pin mux select bits for GPIOX_6
[31:28]	R/W	0	pin mux select bits for GPIOX_7

Table 7-206 PERIPHS\_PIN\_MUX\_4 0xb4

Bit(s)	R/W	Default	Description
[3:0]	R/W	0	pin mux select bits for GPIOX_8
[7:4]	R/W	0	pin mux select bits for GPIOX_9
[11:8]	R/W	0	pin mux select bits for GPIOX_10
[15:12]	R/W	0	pin mux select bits for GPIOX_11
[19:16]	R/W	0	pin mux select bits for GPIOX_12
[23:20]	R/W	0	pin mux select bits for GPIOX_13
[27:24]	R/W	0	pin mux select bits for GPIOX_14
[31:28]	R/W	0	pin mux select bits for GPIOX_15

Table 7-207 PERIPHS\_PIN\_MUX\_5 0xb5

Bit(s)	R/W	Default	Description
[3:0]	R/W	0	pin mux select bits for GPIOX_16
[7:4]	R/W	0	pin mux select bits for GPIOX_17

Bit(s)	R/W	Default	Description
[11:8]	R/W	0	pin mux select bits for GPIOX_18
[15:12]	R/W	0	pin mux select bits for GPIOX_19

Table 7-208 PERIPHS\_PIN\_MUX\_6 0xb6

Bit(s)	R/W	Default	Description
[3:0]	R/W	0	pin mux select bits for GPIOZ_0
[7:4]	R/W	0	pin mux select bits for GPIOZ_1
[11:8]	R/W	0	pin mux select bits for GPIOZ_2
[15:12]	R/W	0	pin mux select bits for GPIOZ_3
[19:16]	R/W	0	pin mux select bits for GPIOZ_4
[23:20]	R/W	0	pin mux select bits for GPIOZ_5
[27:24]	R/W	0	pin mux select bits for GPIOZ_6
[31:28]	R/W	0	pin mux select bits for GPIOZ_7

Table 7-209 PERIPHS\_PIN\_MUX\_7 0xb7

Bit(s)	R/W	Default	Description
[3:0]	R/W	0	pin mux select bits for GPIOZ_8
[7:4]	R/W	0	pin mux select bits for GPIOZ_9
[11:8]	R/W	0	pin mux select bits for GPIOZ_10
[15:12]	R/W	0	pin mux select bits for GPIOZ_11
[19:16]	R/W	0	pin mux select bits for GPIOZ_12
[23:20]	R/W	0	pin mux select bits for GPIOZ_13
[27:24]	R/W	0	pin mux select bits for GPIOZ_14
[31:28]	R/W	0	pin mux select bits for GPIOZ_15

**PERIPHS\_PIN\_MUX\_8 0xb8**

Reserved.

**Table 7-210 PERIPHS\_PIN\_MUX\_9 0xb9**

Bit(s)	R/W	Default	Description
[3:0]	R/W	0	pin mux select bits for GPIOC_0
[7:4]	R/W	0	pin mux select bits for GPIOC_1
[11:8]	R/W	0	pin mux select bits for GPIOC_2
[15:12]	R/W	0	pin mux select bits for GPIOC_3
[19:16]	R/W	0	pin mux select bits for GPIOC_4
[23:20]	R/W	0	pin mux select bits for GPIOC_5
[27:24]	R/W	0	pin mux select bits for GPIOC_6
[31:28]	R/W	0	pin mux select bits for GPIOC_7

**PERIPHS\_PIN\_MUX\_A 0xba**

Reserved.

**Table 7-211 PERIPHS\_PIN\_MUX\_B 0xbb**

Bit(s)	R/W	Default	Description
[3:0]	R/W	0	pin mux select bits for GPIOH_0
[7:4]	R/W	0	pin mux select bits for GPIOH_1
[11:8]	R/W	0	pin mux select bits for GPIOH_2
[15:12]	R/W	0	pin mux select bits for GPIOH_3
[19:16]	R/W	0	pin mux select bits for GPIOH_4
[23:20]	R/W	0	pin mux select bits for GPIOH_5
[27:24]	R/W	0	pin mux select bits for GPIOH_6
[31:28]	R/W	0	pin mux select bits for GPIOH_7

Table 7-212 PERIPHS\_PIN\_MUX\_C 0xbc

Bit(s)	R/W	Default	Description
[3:0]	R/W	0	pin mux select bits for GPIOH_8

Table 7-213 PERIPHS\_PIN\_MUX\_D 0xbd

Bit(s)	R/W	Default	Description
[3:0]	R/W	0	pin mux select bits for GPIOA_0
[7:4]	R/W	0	pin mux select bits for GPIOA_1
[11:8]	R/W	0	pin mux select bits for GPIOA_2
[15:12]	R/W	0	pin mux select bits for GPIOA_3
[19:16]	R/W	0	pin mux select bits for GPIOA_4
[23:20]	R/W	0	pin mux select bits for GPIOA_5
[27:24]	R/W	0	pin mux select bits for GPIOA_6
[31:28]	R/W	0	pin mux select bits for GPIOA_7

Table 7-214 PERIPHS\_PIN\_MUX\_E 0xbe

Bit(s)	R/W	Default	Description
[3:0]	R/W	0	pin mux select bits for GPIOA_8
[7:4]	R/W	0	pin mux select bits for GPIOA_9
[11:8]	R/W	0	pin mux select bits for GPIOA_10
[15:12]	R/W	0	pin mux select bits for GPIOA_11
[19:16]	R/W	0	pin mux select bits for GPIOA_12
[23:20]	R/W	0	pin mux select bits for GPIOA_13
[27:24]	R/W	0	pin mux select bits for GPIOA_14
[31:28]	R/W	0	pin mux select bits for GPIOA_15

**PERIPHS\_PIN\_MUX\_F 0xbf**

Reserved.



### 7.9.3.2 Pad Pull-up/down Direction

The I/O pads contain both a pull-up and a pull-down. If a bit is set to 1 in the registers below, then the pull-up is enabled. If a bit is set to 0, then the pull-down is enabled.

#### Note

There are separate pull-up “enables” that must also be set to 1 for the pull-up/down direction to function. If an “enable” is set to 0, then the pull-up/down feature is disabled, and the bits below are ignored (on a per pad basis).

**Table 7-215 PAD\_PULL\_UP\_REG0 0x3a**

Bit(s)	R/W	Default	Description
31:16	R/W	0xcfff	Unused
15:0	R/W		Boot[15:0] 1 = pull up. 0 = pull down

**Table 7-216 PAD\_PULL\_UP\_REG1 0x3b**

Bit(s)	R/W	Default	Description
37:0	R/W	0xff	Unused
6:0	R/W		gpioC[6 :0] 1 = pull up. 0 = pull down

**Table 7-217 PAD\_PULL\_UP\_REG2 0x3c**

Bit(s)	R/W	Default	Description
31:20	R/W	0x5ffb	Reserved
19:0	R/W		gpioX[19:0] 1 = pull up. 0 = pull down

**Table 7-218 PAD\_PULL\_UP\_REG3 0x3d**

Bit(s)	R/W	Default	Description
31:8	R/W	0x10f	Reserved
7:4	R/W		gpioH[7:4] 1 = pull up. 0 = pull down
3:0	R/W		Reserved

**Table 7-219 PAD\_PULL\_UP\_REG4 0x3e**

Bit(s)	R/W	Default	Description
31:14	R/W	0xc1ff	Unused
13:0	R/W		gpioZ[13:0] 1 = pull up. 0 = pull down

**Table 7-220 PAD\_PULL\_UP\_REG5 0x3f**

Bit(s)	R/W	Default	Description
31:16	R/W	0xc000	Unused
15:0	R/W		gpioA[15:0] 1 = pull up. 0 = pull down

### 7.9.3.3 Pad Pull-up/down Enables

Each I/O pad has a selectable pull-up or pull-down resistor. For the pull-up direction (up or down) to be operational, the appropriate bit below must be set in order to enable the pull-up/down function.

**Table 7-221 PAD\_PULL\_UP\_EN\_REG0 0x48**

Bit(s)	R/W	Default	Description
31:16	R/W	0xffff	Unused
15:0	R/W		boot[15:0] pullup-enable: 1 = pullup or pull-down enabled. 0 = no-pull-up or pull-down

**Table 7-222 PAD\_PULL\_UP\_EN\_REG1 0x49**

Bit(s)	R/W	Default	Description
31:7	R/W	0xff	Unused
6:0	R/W		gpioC[6:0] pullup-enable: 1 = pullup or pull-down enabled. 0 = no-pull-up or pull-down

**Table 7-223 PAD\_PULL\_UP\_EN\_REG2 0x4a**

Bit(s)	R/W	Default	Description
31:20	R/W	0x7fff	Reserved
19:0	R/W		gpioX[19:0] pullup-enable: 1 = pullup or pull-down enabled. 0 = no-pull-up or pull-down

**Table 7-224 PAD\_PULL\_UP\_EN\_REG3 0x4b**

Bit(s)	R/W	Default	Description
31:8	R/W	0x1ff	reserved
7:4	R/W		gpioH[7:4] pullup-enable: 1 = pullup or pull-down enabled. 0 = no-pull-up or pull-down
3:0	R/W		reserved

**Table 7-225 PAD\_PULL\_UP\_EN\_REG4 0x4c**

Bit(s)	R/W	Default	Description
31:14	R/W	0x3fff	reserved
13:0	R/W		gpioZ[13:0] pullup-enable: 1 = pullup or pull-down enabled. 0 = no-pull-up or pull-down

**Table 7-226 PAD\_PULL\_UP\_EN\_REG5 0x4d**

Bit(s)	R/W	Default	Description
31:16	R/W	0xffff	reserved

Bit(s)	R/W	Default	Description
15:0	R/W		gpioA[15:0] pullup-enable: 1 = pullup or pull-down enabled. 0 = no-pull-up or pull-down

### 7.9.3.4 PREG\_PAD\_GPIO\_I Registers

Table 7-227 PREG\_PAD\_GPIO0\_I Registers 0x12

Bit(s)	R/W	Default	Description
0	R/W	0	BOOT_0 select
1	R/W	0	BOOT_1 select
2	R/W	0	BOOT_2 select
3	R/W	0	BOOT_3 select
4	R/W	0	BOOT_4 select
5	R/W	0	BOOT_5 select
6	R/W	0	BOOT_6 select
7	R/W	0	BOOT_7 select
8	R/W	0	BOOT_8 select
9	R/W	0	BOOT_9 select
10	R/W	0	BOOT_10 select
11	R/W	0	BOOT_11 select
12	R/W	0	BOOT_12 select
13	R/W	0	BOOT_13 select
14	R/W	0	BOOT_14 select
15	R/W	0	BOOT_15 select

Table 7-228 PREG\_PAD\_GPIO1\_I Registers 0x15

Bit(s)	R/W	Default	Description
0	R/W	0	GPIOC_0 select
1	R/W	0	GPIOC_1 select
2	R/W	0	GPIOC_2 select
3	R/W	0	GPIOC_3 select
4	R/W	0	GPIOC_4 select
5	R/W	0	GPIOC_5 select
6	R/W	0	GPIOC_6 select
7	R/W	0	GPIOC_7 select

Table 7-229 PREG\_PAD\_GPIO2\_I Registers 0x18

Bit(s)	R/W	Default	Description
0	R/W	0	GPIOX_0 select
1	R/W	0	GPIOX_1 select
2	R/W	0	GPIOX_2 select
3	R/W	0	GPIOX_3 select
4	R/W	0	GPIOX_4 select
5	R/W	0	GPIOX_5 select
6	R/W	0	GPIOX_6 select
7	R/W	0	GPIOX_7 select
8	R/W	0	GPIOX_8 select
9	R/W	0	GPIOX_9 select
10	R/W	0	GPIOX_10 select
11	R/W	0	GPIOX_11 select
12	R/W	0	GPIOX_12 select
13	R/W	0	GPIOX_13 select
14	R/W	0	GPIOX_14 select
15	R/W	0	GPIOX_15 select
16	R/W	0	GPIOX_16 select
17	R/W	0	GPIOX_17 select
18	R/W	0	GPIOX_18 select
19	R/W	0	GPIOX_19 select

Table 7-230 PREG\_PAD\_GPIO3\_I Registers 0x1b

Bit(s)	R/W	Default	Description
0	R/W	0	GPIOH_0 select
1	R/W	0	GPIOH_1 select
2	R/W	0	GPIOH_2 select
3	R/W	0	GPIOH_3 select
4	R/W	0	GPIOH_4 select
5	R/W	0	GPIOH_5 select
6	R/W	0	GPIOH_6 select
7	R/W	0	GPIOH_7 select
8	R/W	0	GPIOH_8 select

Table 7-231 PREG\_PAD\_GPIO4\_I Registers 0x1e

Bit(s)	R/W	Default	Description
0	R/W	0	GPIOZ_0 select
1	R/W	0	GPIOZ_1 select
2	R/W	0	GPIOZ_2 select
3	R/W	0	GPIOZ_3 select
4	R/W	0	GPIOZ_4 select
5	R/W	0	GPIOZ_5 select
6	R/W	0	GPIOZ_6 select
7	R/W	0	GPIOZ_7 select
8	R/W	0	GPIOZ_8 select
9	R/W	0	GPIOZ_9 select
10	R/W	0	GPIOZ_10 select
11	R/W	0	GPIOZ_11 select
12	R/W	0	GPIOZ_12 select
13	R/W	0	GPIOZ_13 select

Table 7-232 PREG\_PAD\_GPIO5\_I Registers 0x22

Bit(s)	R/W	Default	Description
0	R/W	0	GPIOA_0 select
1	R/W	0	GPIOA_1 select
2	R/W	0	GPIOA_2 select
3	R/W	0	GPIOA_3 select
4	R/W	0	GPIOA_4 select
5	R/W	0	GPIOA_5 select
6	R/W	0	GPIOA_6 select
7	R/W	0	GPIOA_7 select
8	R/W	0	GPIOA_8 select
9	R/W	0	GPIOA_9 select
10	R/W	0	GPIOA_10 select
11	R/W	0	GPIOA_11 select
12	R/W	0	GPIOA_12 select
13	R/W	0	GPIOA_13 select
14	R/W	0	GPIOA_14 select
15	R/W	0	GPIOA_15 select

### 7.9.3.5 PREG\_PAD\_GPIO\_O Registers

Table 7-233 PREG\_PAD\_GPIO0\_O Registers 0x11

Bit(s)	R/W	Default	Description
0	R/W	1	BOOT_0 select
1	R/W	1	BOOT_1 select
2	R/W	1	BOOT_2 select
3	R/W	1	BOOT_3 select
4	R/W	1	BOOT_4 select
5	R/W	1	BOOT_5 select
6	R/W	1	BOOT_6 select
7	R/W	1	BOOT_7 select
8	R/W	1	BOOT_8 select
9	R/W	1	BOOT_9 select
10	R/W	1	BOOT_10 select
11	R/W	1	BOOT_11 select
12	R/W	1	BOOT_12 select
13	R/W	1	BOOT_13 select
14	R/W	1	BOOT_14 select
15	R/W	1	BOOT_15 select

Table 7-234 PREG\_PAD\_GPIO1\_O Registers 0x14

Bit(s)	R/W	Default	Description
0	R/W	1	GPIOC_0 select
1	R/W	1	GPIOC_1 select
2	R/W	1	GPIOC_2 select
3	R/W	1	GPIOC_3 select
4	R/W	1	GPIOC_4 select
5	R/W	1	GPIOC_5 select
6	R/W	1	GPIOC_6 select

Table 7-235 PREG\_PAD\_GPIO2\_O Registers 0x17

Bit(s)	R/W	Default	Description
0	R/W	1	GPIOX_0 select
1	R/W	1	GPIOX_1 select
2	R/W	1	GPIOX_2 select
3	R/W	1	GPIOX_3 select

Bit(s)	R/W	Default	Description
4	R/W	1	GPIOX_4 select
5	R/W	1	GPIOX_5 select
6	R/W	1	GPIOX_6 select
7	R/W	1	GPIOX_7 select
8	R/W	1	GPIOX_8 select
9	R/W	1	GPIOX_9 select
10	R/W	1	GPIOX_10 select
11	R/W	1	GPIOX_11 select
12	R/W	1	GPIOX_12 select
13	R/W	1	GPIOX_13 select
14	R/W	1	GPIOX_14 select
15	R/W	1	GPIOX_15 select
16	R/W	1	GPIOX_16 select
17	R/W	1	GPIOX_17 select
18	R/W	1	GPIOX_18 select
19	R/W	1	GPIOX_19 select

Table 7-236 PREG\_PAD\_GPIO3\_O Registers 0x1a

Bit(s)	R/W	Default	Description
4	R/W	1	GPIOH_4 select
5	R/W	1	GPIOH_5 select
6	R/W	1	GPIOH_6 select
7	R/W	1	GPIOH_7 select

Table 7-237 PREG\_PAD\_GPIO4\_O Registers 0x1d

Bit(s)	R/W	Default	Description
0	R/W	1	GPIOZ_0 select
1	R/W	1	GPIOZ_1 select
2	R/W	1	GPIOZ_2 select
3	R/W	1	GPIOZ_3 select
4	R/W	1	GPIOZ_4 select
5	R/W	1	GPIOZ_5 select
6	R/W	1	GPIOZ_6 select
7	R/W	1	GPIOZ_7 select
8	R/W	1	GPIOZ_8 select

Bit(s)	R/W	Default	Description
9	R/W	1	GPIOZ_9 select
10	R/W	1	GPIOZ_10 select
11	R/W	1	GPIOZ_11 select
12	R/W	1	GPIOZ_12 select
13	R/W	1	GPIOZ_13 select

Table 7-238 PREG\_PAD\_GPIO5\_O Registers 0x21

Bit(s)	R/W	Default	Description
0	R/W	1	GPIOA_0 select
1	R/W	1	GPIOA_1 select
2	R/W	1	GPIOA_2 select
3	R/W	1	GPIOA_3 select
4	R/W	1	GPIOA_4 select
5	R/W	1	GPIOA_5 select
6	R/W	1	GPIOA_6 select
7	R/W	1	GPIOA_7 select
8	R/W	1	GPIOA_8 select
9	R/W	1	GPIOA_9 select
10	R/W	1	GPIOA_10 select
11	R/W	1	GPIOA_11 select
12	R/W	1	GPIOA_12 select
13	R/W	1	GPIOA_13 select
14	R/W	1	GPIOA_14 select
15	R/W	1	GPIOA_15 select

### 7.9.3.6 PREG\_PAD\_GPIO\_EN\_N Registers

Table 7-239 PREG\_PAD\_GPIO0\_EN\_N 0x10

Bit(s)	R/W	Default	Description
0	R/W	1	BOOT_0 select
1	R/W	1	BOOT_1 select
2	R/W	1	BOOT_2 select
3	R/W	1	BOOT_3 select
4	R/W	1	BOOT_4 select
5	R/W	1	BOOT_5 select



Bit(s)	R/W	Default	Description
6	R/W	1	BOOT_6 select
7	R/W	1	BOOT_7 select
8	R/W	1	BOOT_8 select
9	R/W	1	BOOT_9 select
10	R/W	1	BOOT_10 select
11	R/W	1	BOOT_11 select
12	R/W	1	BOOT_12 select
13	R/W	1	BOOT_13 select
14	R/W	1	BOOT_14 select
15	R/W	1	BOOT_15 select

Table 7-240 PREG\_PAD\_GPIO1\_EN\_N 0x13

Bit(s)	R/W	Default	Description
0	R/W	1	GPIOC_0 select
1	R/W	1	GPIOC_1 select
2	R/W	1	GPIOC_2 select
3	R/W	1	GPIOC_3 select
4	R/W	1	GPIOC_4 select
5	R/W	1	GPIOC_5 select
6	R/W	1	GPIOC_6 select
7	R/W	1	GPIOC_7 select

Table 7-241 PREG\_PAD\_GPIO2\_EN\_N 0x16

Bit(s)	R/W	Default	Description
0	R/W	1	GPIOX_0 select
1	R/W	1	GPIOX_1 select
2	R/W	1	GPIOX_2 select
3	R/W	1	GPIOX_3 select
4	R/W	1	GPIOX_4 select
5	R/W	1	GPIOX_5 select
6	R/W	1	GPIOX_6 select
7	R/W	1	GPIOX_7 select
8	R/W	1	GPIOX_8 select
9	R/W	1	GPIOX_9 select
10	R/W	1	GPIOX_10 select

Bit(s)	R/W	Default	Description
11	R/W	1	GPIOX_11 select
12	R/W	1	GPIOX_12 select
13	R/W	1	GPIOX_13 select
14	R/W	1	GPIOX_14 select
15	R/W	1	GPIOX_15 select
16	R/W	1	GPIOX_16 select
17	R/W	1	GPIOX_17 select
18	R/W	1	GPIOX_18 select
19	R/W	1	GPIOX_19 select

Table 7-242 PREG\_PAD\_GPIO3\_EN\_N 0x19

Bit(s)	R/W	Default	Description
0	R/W	1	GPIOH_0 select
1	R/W	1	GPIOH_1 select
2	R/W	1	GPIOH_2 select
3	R/W	1	GPIOH_3 select
4	R/W	1	GPIOH_4 select
5	R/W	1	GPIOH_5 select
6	R/W	1	GPIOH_6 select
7	R/W	1	GPIOH_7 select
8	R/W	1	GPIOH_8 select

Table 7-243 PREG\_PAD\_GPIO4\_EN\_N 0x1c

Bit(s)	R/W	Default	Description
0	R/W	1	GPIOZ_0 select
1	R/W	1	GPIOZ_1 select
2	R/W	1	GPIOZ_2 select
3	R/W	1	GPIOZ_3 select
4	R/W	1	GPIOZ_4 select
5	R/W	1	GPIOZ_5 select
6	R/W	1	GPIOZ_6 select
7	R/W	1	GPIOZ_7 select
8	R/W	1	GPIOZ_8 select
9	R/W	1	GPIOZ_9 select
10	R/W	1	GPIOZ_10 select

Bit(s)	R/W	Default	Description
11	R/W	1	GPIOZ_11 select
12	R/W	1	GPIOZ_12 select
13	R/W	1	GPIOZ_13 select
14	R/W	1	GPIOZ_14 select
15	R/W	1	GPIOZ_15 select

Table 7-244 PREG\_PAD\_GPIO5\_EN\_N 0x20

Bit(s)	R/W	Default	Description
0	R/W	1	GPIOA_0 select
1	R/W	1	GPIOA_1 select
2	R/W	1	GPIOA_2 select
3	R/W	1	GPIOA_3 select
4	R/W	1	GPIOA_4 select
5	R/W	1	GPIOA_5 select
6	R/W	1	GPIOA_6 select
7	R/W	1	GPIOA_7 select
8	R/W	1	GPIOA_8 select
9	R/W	1	GPIOA_9 select
10	R/W	1	GPIOA_10 select
11	R/W	1	GPIOA_11 select
12	R/W	1	GPIOA_12 select
13	R/W	1	GPIOA_13 select
14	R/W	1	GPIOA_14 select
15	R/W	1	GPIOA_15 select

### 7.9.3.7 PAD\_DS Registers

Table 7-245 PAD\_DS\_REG0A 0xd0

Bit(s)	R/W	Default	Description
[1:0]	R/W	0xaaaa-aaaa	BOOT_0 select
[3:2]	R/W		BOOT_1 select
[5:4]	R/W		BOOT_2 select
[7:6]	R/W		BOOT_3 select
[9:8]	R/W		BOOT_4 select
[11:10]	R/W		BOOT_5 select

Bit(s)	R/W	Default	Description
[13:12]	R/W		BOOT_6 select
[15:14]	R/W		BOOT_7 select
[17:16]	R/W		BOOT_8 select
[19:18]	R/W		BOOT_9 select
[21:20]	R/W		BOOT_10 select
[23:22]	R/W		BOOT_11 select
[25:24]	R/W		BOOT_12 select
[27:26]	R/W		BOOT_13 select
[29:28]	R/W		BOOT_14 select
[31:30]	R/W		BOOT_15 select

Table 7-246 PAD\_DS\_REG1A 0xd1

Bit(s)	R/W	Default	Description
[1:0]	R/W	0xaaa- a9aaa	GPIOC_0 select
[3:2]	R/W		GPIOC_1 select
[5:4]	R/W		GPIOC_2 select
[7:6]	R/W		GPIOC_3 select
[9:8]	R/W		GPIOC_4 select
[11:10]	R/W		GPIOC_5 select
[13:12]	R/W		GPIOC_6 select

Table 7-247 PAD\_DS\_REG2A 0xd2

Bit(s)	R/W	Default	Description
[1:0]	R/W	0x5595- 5aaa	GPIOX_0 select
[3:2]	R/W		GPIOX_1 select
[5:4]	R/W		GPIOX_2 select
[7:6]	R/W		GPIOX_3 select
[9:8]	R/W		GPIOX_4 select
[11:10]	R/W		GPIOX_5 select
[13:12]	R/W		GPIOX_6 select
[15:14]	R/W		GPIOX_7 select
[17:16]	R/W		GPIOX_8 select
[19:18]	R/W		GPIOX_9 select
[21:20]	R/W		GPIOX_10 select
[23:22]	R/W		GPIOX_11 select

Bit(s)	R/W	Default	Description
[25:24]	R/W		GPIOX_12 select
[27:26]	R/W		GPIOX_13 select
[29:28]	R/W		GPIOX_14 select
[31:30]	R/W		GPIOX_15 select

Table 7-248 PAD\_DS\_REG2B 0xd3

Bit(s)	R/W	Default	Description
[1:0]	R/W	0xaaaa- aa55	GPIOX_16 select
[3:2]	R/W		GPIOX_17 select
[5:4]	R/W		GPIOX_18 and GPIOX_19 select

Table 7-249 PAD\_DS\_REG3A 0xd4

Bit(s)	R/W	Default	Description
[9:8]	R/W	0xaaa- a55aa	GPIOH_4 select
[11:10]	R/W		GPIOH_5 select
[13:12]	R/W		GPIOH_6 select
[15:14]	R/W		GPIOH_7 select

Table 7-250 PAD\_DS\_REG4A 0xd5

Bit(s)	R/W	Default	Description
[1:0]	R/W	0xaaaa- aaa5	GPIOZ_0 select
[3:2]	R/W		GPIOZ_1 select
[5:4]	R/W		GPIOZ_2 select
[7:6]	R/W		GPIOZ_3 select
[9:8]	R/W		GPIOZ_4 select
[11:10]	R/W		GPIOZ_5 select
[13:12]	R/W		GPIOZ_6 select
[15:14]	R/W		GPIOZ_7 select
[17:16]	R/W		GPIOZ_8 select
[19:18]	R/W		GPIOZ_9 select
[21:20]	R/W		GPIOZ_10 select
[23:22]	R/W		GPIOZ_11 select
[25:24]	R/W		GPIOZ_12 select
[27:26]	R/W	GPIOZ_13 select	

Table 7-251 PAD\_DS\_REG5A 0xd6

Bit(s)	R/W	Default	Description
[1:0]	R/W	0x5695-555a	GPIOA_0 select
[3:2]	R/W		GPIOA_1 select
[5:4]	R/W		GPIOA_2 select
[7:6]	R/W		GPIOA_3 select
[9:8]	R/W		GPIOA_4 select
[11:10]	R/W		GPIOA_5 select
[13:12]	R/W		GPIOA_6 select
[15:14]	R/W		GPIOA_7 select
[17:16]	R/W		GPIOA_8 select
[19:18]	R/W		GPIOA_9 select
[21:20]	R/W		GPIOA_10 select
[23:22]	R/W		GPIOA_11 select
[25:24]	R/W		GPIOA_12 select
[27:26]	R/W		GPIOA_13 select
[29:28]	R/W		GPIOA_14 select
[31:30]	R/W		GPIOA_15 select

### 7.9.3.8 GPIOAO Registers

Always On GPIO Input levels.

Table 7-252 AO\_GPIO\_I 0x0a

Bit(s)	R/W	Default	Description
31	R	0	TEST_N input level
18:16	R	0	INPUT_LEVELS: These bits correspond to the INPUT levels on the gpioE[2:0] pins
11:00	R	0	INPUT_LEVELS: These bits correspond to the INPUT levels on the gpioAO[11:0] pins

Always On GPIO controls.

#### Caution

This register is NOT reset during a watchdog event.

Table 7-253 AO\_GPIO\_O 0x0d

Bit(s)	R/W	Default	Description
31	R/W	0xffffffff	TEST_N_OUTPUT_LEVEL: This bit controls the output level of the test_n pin when TEST_N_GPIO_EN_N is set to 0.

Bit(s)	R/W	Default	Description
18:16	R/W		OUTPUT_LEVEL: These bits correspond to the output levels on the gpioE[2:0] pins when in GPIO mode.
11:00	R/W		OUTPUT_LEVEL: These bits correspond to the output levels on the gpioAO [11:0] pins when in GPIO mode.

Table 7-254 AO\_RTI\_PINMUX\_REG0 0x05

Bit(s)	R/W	Default	Description
1900-01-01	R/W	0	gpioAO_7 select
1900-01-01	R/W	0	gpioAO_6 select
23:20	R/W	0	gpioAO_5 select
19:16	R/W	0	gpioAO_4 select
15:12	R/W	0	gpioAO_3 select
11:08	R/W	0	gpioAO_2 select
07:04	R/W	0	gpioAO_1 select
3:0	R/W	0	gpioAO_0 select

Table 7-255 AO\_RTI\_PINMUX\_REG1 0x06

Bit(s)	R/W	Default	Description
31:28	R/W	0	gpioAO TEST_N
27:24	R/W	0	gpioE_2 select
[23:20]	R/W	0	gpioE_1 select
[19:16]	R/W	0	gpioE_0 select
[15:12]	R/W	0	gpioAO_11 select
[11:8]	R/W	0	gpioAO_10 select
[7:4]	R/W	0	gpioAO_9 select
[3:0]	R/W	0	gpioAO_8 select

Always On GPIO controls.

### Caution

This register is NOT reset during a watchdog event.

Table 7-256 AO\_GPIO\_O\_EN\_N 0x09

Bit(s)	R/W	Default	Description
30-19	R	0xffffffff	Reserved
18-16	R/W		OUTPUT_ENABLE: These bits correspond to the output levels on the gpioE[2:0] pins when in GPIO mode. A '0' sets the gpioE pin to be an output.

Bit(s)	R/W	Default	Description
15-12	R		Reserved
11-0	R/W		OUTPUT_ENABLE: These bits correspond to the output levels on the gpioAO [11:0] pins when in GPIO mode. A '0' sets the gpioAO pin to be an output.

Table 7-257 AO\_RTI\_PULL\_UP\_REG 0x0b

Bit(s)	R/W	Default	Description
31	R/W	0x8000-05ab	TEST_N pull up/down. 1 = pull-up 0 = pull-down
18-16	R/W		gpioE[2:0] pull-up/down. 1 = pull-up 0 = pull-down
11-0	R/W		gpioAO[11:0] pull up/down. 1 = pull-up 0 = pull-down

Always On GPIO controls.

### Caution

This register is NOT reset during a watchdog event.

Table 7-258 AO\_RTI\_PULL\_UP\_EN\_REG 0x0c

Bit(s)	R/W	Default	Description
31	R/W	0x8004-0fff	TEST_N pull-up/down enable. 1 = pull-up/down enable, 0 = pull-up/down disable
18-16	R/W		gpioE[2:0] pull-up/down enable. 1 = pull-up/down enable, 0 = pull-up/down disable
11-0	R/W		gpioAO[11:0] pull-up/down enable. 1 = pull-up/down enable, 0 = pull-up/down disable

Pad ds0/ds1

Table 7-259 AO\_PAD\_DS\_A 0x07

Bit(s)	R/W	Default	Description
23:22	R/W	0xaaaa-aaaa	gpioAO_11{ds1 ds0}
21:20	R/W		gpioAO_10{ds1 ds0}
19:18	R/W		gpioAO_9{ds1 ds0}
17:16	R/W		gpioAO_8{ds1 ds0}
15:14	R/W		gpioAO_7{ds1 ds0}
13:12	R/W		gpioAO_6{ds1 ds0}
11:10	R/W		gpioAO_5{ds1 ds0}
9:8	R/W		gpioAO_4{ds1 ds0}
7:6	R/W		gpioAO_3{ds1 ds0}
5:4	R/W		gpioAO_2{ds1 ds0}



Bit(s)	R/W	Default	Description
3:2	R/W		gpioAO_1{ds1 ds0}
1:0	R/W		gpioAO_0 {ds1 ds0}

Pad ds0/ds1

**Table 7-260 AO\_PAD\_DS\_B 0x08**

Bit(s)	R/W	Default	Description
31:30	R/W	0xaaaa-aaaa	reset_n {ds1, ds0}
29:28	R/W		test_n {ds1, ds0}
5:4	R/W		gpioE_2 {ds1 ds0}
3:2	R/W		gpioE_1 {ds1 ds0}
1:0	R/W		gpioE_0 {ds1 ds0}

**Table 7-261 AO\_PINMUX\_LOCK 0x17**

Bit(s)	R/W	Default	Description
31	R/W	0	1: generate error when write to each locked register;
7	R/W	0	lock ao gpio_o
6	R/W	0	lock ao gpio pull en
5	R/W	0	lock ao gpio pull up
4	R/W	0	lock ao gpio_o_en
1	R/W	0	lock ao pin_mux_reg1
0	R/W	0	lock ao pin_mux_reg0

## 7.10 Interrupt Control

### 7.10.1 Overview

Generic Interrupt Controller (GIC) is a centralized resource that supports and manages interrupts in a system. For more details about GIC, please refer to the ARM GIC Architecture Specification V2.0.

### 7.10.2 Interrupt Source

There are 224 interrupt sources in the chip. All of the interrupts are connected to the integrated GIC in Cortex-A55 while the AO-CPU see a sub-set of the interrupts. The control Bits of AO-CPU interrupt are listed in the following table.

A55 GIC Bit	Interrupt Source	Description
255	pcie_A_7	
254	pcie_A_6	

A55 GIC Bit	Interrupt Source	Description
253	pcie_A_5	
252	pcie_A_4	
251	pcie_A_3	
250	pcie_A_2	
249	pcie_A_1	
248	pcie_A_0	
247	m_i2c_2_irq	
246	m_i2c_1_irq	
245	mbox_irq_send5	
244	mbox_irq_send4	
243	mbox_irq_send3	
242	mbox_irq_receive2	
241	mbox_irq_receive1	
240	mbox_irq_receive0	
239	ao_gpio_irq1	
238	ao_gpio_irq0	
237	ao_timerB_irq	
236	ao_timerA_irq	
235	cecb_irq	
234	ao_watchdog_irq	
233	ao_m_i2c_to_irq	
232	sar_adc_irq	
231	ao_cec_irq	
230	ao_ir_blaster_irq	
229	ao_uart2_irq	
228	ao_ir_dec_irq	
227	ao_i2c_m_irq	
226	ao_i2c_s_irq	
225	ao_uart_irq	
224	1'b0	
223	SD_EMMC_C	
222	SD_EMMC_B	
221	SD_EMMC_A	
220	HEVC Encoder_VPU_IDLE	
219	HEVC Encoder	

A55 GIC Bit	Interrupt Source	Description
218	NN	
217	dma_irq[5]	
216	dma_irq[4]	
215	dma_irq[3]	
214	dma_irq[2]	
213	dma_irq[1]	
212	dma_irq[0]	
211	eth_phy_irq8	
210	eth_phy_irq7	
209	eth_phy_irq6	
208	eth_phy_irq5	
207	eth_phy_irq4	
206	eth_phy_irq3	
205	eth_phy_irq2	
204	eth_phy_irq1	
203	eth_phy_irq0	
202	mali_irq_pp3	reserved
201	mali_irq_ppmmu2	reserved
200	mali_irq_pp2	reserved
199	mali_irq_ppmmu1	reserved
198	mali_irq_pp1	reserved
197	mali_irq_ppmmu0	reserved
196	mali_irq_pp0	reserved
195	mali_irq_pmu	
194	mali_irq_pp	
193	mali_irq_gpmmu	
192	mali_irq_gp	
191	PCIE_A_EDMA_RD	
190	PCIE_A_EDMA_WR	
189	locker	
188	toram	
187	vad_flag	
186	frddr_C	
185	frddr_B	
184	frddr_A	

A55 GIC Bit	Interrupt Source	Description
183	spdifin	
182	toddr_C	
181	toddr_B	
180	toddr_A	
179	1'b0	
178	ge2d	
177	cusad	
176	a55irq[6]	
175	viu1_wm_int	
174	a55irq[5]	
173	a55irq[4]	EXTERRIRQ_a
172	a55irq[3]	CTIIRQ[3:0]
171	a55irq[2]	VCPUMNTIRQ_a[3:0]
170	a55irq[1]	COMMIRQ_a[3:0]
169	a55irq[0]	PMUIRQ_a[3:0]
168	mbox_rec7	
167	mbox_sed6	
166		
165		
164	viu1_line	
163	asssit_mbox_irq3	
162	asssit_mbox_irq2	
161	asssit_mbox_irq1	
160	asssit_mbox_irq0	
127	m_i2c_3_TO	
126	m_i2c_2_TO	
125	uart2_irq	
124	m_i2c_1_TO	
123	m_i2c_0_TO	
122	spicc_1_int	
121	rdma_done_int	
120		
119		
118	vid1_wr_irq	
117	vdin1_vsync_int	

A55 GIC Bit	Interrupt Source	Description
116	vdin1_hsync_int	
115	vdin0_vsync_int	
114	vdin0_hsync_int	
113	spicc_0_int	
112	spi_int	
111	vid0_wr_irq	
110	venc_vx1_int	
109	viu1_dolby_int	
108	viu1_mail_afbc	
107	uart1_irq	
106	lc_curve	
105	vpu_crash	
104	parser1	
103	gpio_irq[7]	
102	gpio_irq[6]	
101	gpio_irq[5]	
100	gpio_irq[4]	
99	gpio_irq[3]	
98	gpio_irq[2]	
97	gpio_irq[1]	
96	gpio_irq[0]	
95	TimerI	TimerI
94	TimerH	TimerH
93	TimerG	TimerG
92	TimerF	TimerF
91	viu2_line	
90	htx_hdcp22_intr	
89	hdmitx_interrupt	
88	viu2_vsync	
87	viu2_hsync	
86	dmc_test_irq	
85	demux_int_2	
84	dmc_irq	
83	dmc_sec_irq	
82	frdd_d	

A55 GIC Bit	Interrupt Source	Description
81	toddr_d	
80	vad_fs	
79	spdifin_lb	
78	di_pre	Reserved for Deinterlacer
77	dos_mbox_slow_irq[2]	DOS Mailbox 2
76	dos_mbox_slow_irq[1]	DOS Mailbox 1
75	dos_mbox_slow_irq[0]	DOS Mailbox 0
74	1'b0	
73	1'b0	
72	di_post	
71	m_i2c_3_irq	I2C Master #3
70	1'b0	
69	smartcard_irq	
68	ts_ddr	
67	ts_pll	
66	nand_irq	
65	viff_empty_int_cpu	
64	parser_int_cpu	
63	U2d_interrupt	USB
62	U3h_interrupt	USB
61	Timer D	Timer D
60	bus_mon1_fast_irq	
59	bus_mon0_fast_irq	
58	uart0_irq	
57	async_fifo2_flush_irq	
56	async_fifo2_fill_irq	
55	demux_int	
54	encif_irq	
53	m_i2c_0_irq	
52	bt656	
51	async_fifo_flush_irq	
50	async_fifo_fill_irq	
49	async_fifo3_flush_irq	
48	usb_iddig_irq	
47	1'b0	unused
46	eth_lip_intro_o	

A55 GIC Bit	Interrupt Source	Description
45	1'b0	
44		
43	Timer B	Timer B
42	Timer A	Timer A
41	eth_phy_irq_or	
40	eth_gmac_int	
39	async_fifo3_fill_irq	
38	Timer C	Timer C
37	demux_int_1	
36	eth_pmt_intr_o	
35	viu1_vsync_int	VSYNC
34	viu1_hsync_int	HSYNC
33		
32	ee_wd_irq	Watchdog Timer

### 7.10.3 GPIO Interrupt

There are 10 interrupts that are routed to all CPUs (A55/SCP). The tables below outline the interrupts associated with each interrupt group.

**Figure 7-26 GPIO Interrupt**

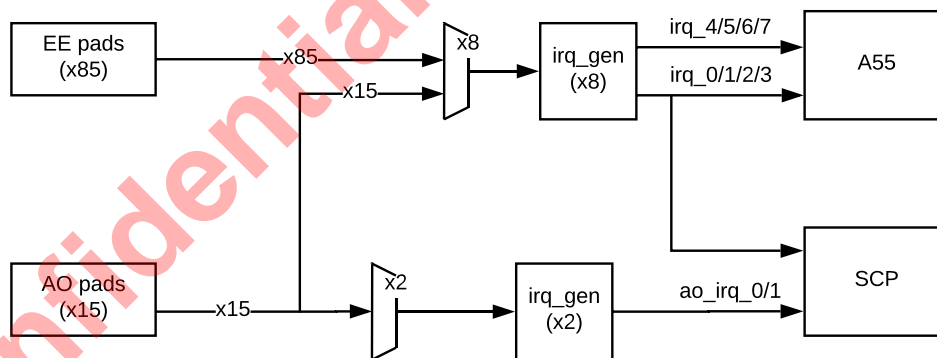

T02FC31

There are 8 independent filtered GPIO interrupt modules that can be programmed to use any of the GPIOs in the chip as an interrupt source (listed in the table below). For example, to select gpioZ\_15 as the source for GPIO IRQ #0, then CBUS 0x2609 bits[7:0] = 27 (according to the table below).

Input Mux Location CBUS registers 0x2621 and 0x2622	Description
[223:100]	0
[99:97]	gpioE[2:0]

Input Mux Location CBUS registers 0x2621 and 0x2622	Description
[96:77]	gpioX[19:0]
[76:61]	gpioA[15:0]
[60:53]	gpioC[7:0]
[52:37]	boot[15:0]
[36:28]	gpioH[8:0]
[27:12]	gpioZ[15:0]
[11:0]	gpioAO[11:0]

The diagram below illustrates the path a GPIO takes to become an interrupt. The eight GPIO interrupts respond to the MASK, STATUS and STATUS/CLEAR registers just like any other interrupt in the chip. The difference for the GPIO interrupts is that they can be filtered and conditioned.

#### Note

The input for the GPIO interrupt module (the input into the 256:1 mux) comes directly from the I/O pad of the chip. Therefore if a pad (say gpioA\_11) is configured as a UART TX pin, then in theory, the UART TX pin can be a GPIO interrupt since the TX pin will drive gpioA\_11 which in turn can drive the GPIO interrupt module.



Figure 7-27 GPIO Interrupt Path

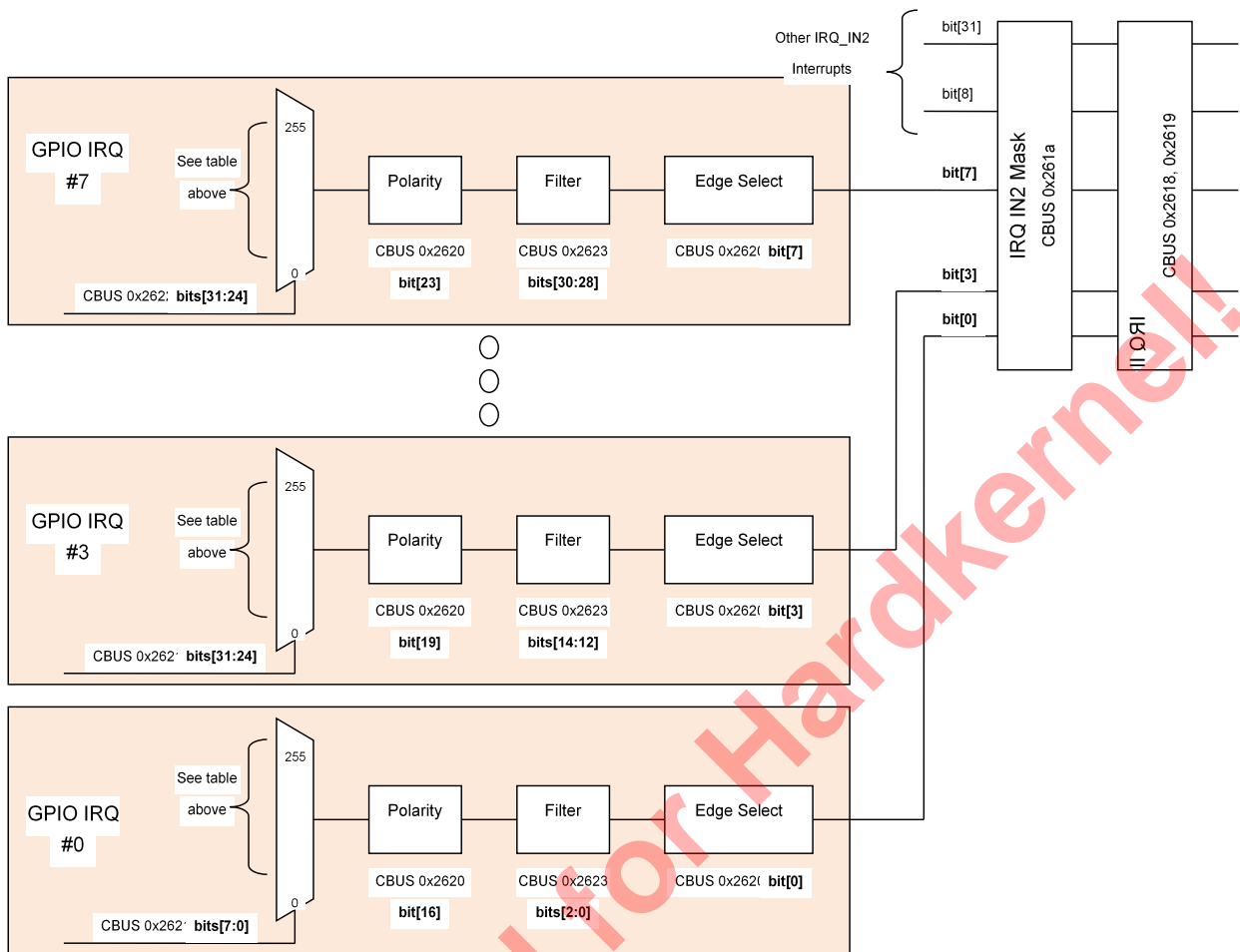

T02FC32

### 7.10.4 Register Description

Each register final address = 0xffd00000 + offset \* 4

This register controls the polarity of the GPIO interrupts and whether or not the interrupts are level or edge triggered. There are 8 GPIO interrupts. These 8 GPIO interrupts can be assigned to any one of up to 256 pins on the chip.

Interrupt masking and FIQ select.

Table 7-262 AO\_IRQ\_GPIO\_REG 0x21

Bit(s)	R/W	Default	Description
31-20	R	0	Unused
21	R/W	0	GPIO_1_IRQ_BOTHEDGE_EN, If this bit is 1, then GPIO_0_IRQ generates an interrupt on the both rising and falling edge of the selected interrupt., this EN is high priority than GPIO_1_IRQ_EDGE
20	R/W	0	GPIO_0_IRQ_BOTHEDGE_EN,

Bit(s)	R/W	Default	Description
			If this bit is 1, then GPIO_0_IRQ generates an interrupt on the both rising and falling edge of the selected interrupt., this EN is high priority than GPIO_0_IRQ_EDGE
19	R/W	0	GPIO_1_IRQ_EDGE: If this bit is 1, then GPIO_1_IRQ generates an interrupt on the rising (or falling edge if GPIO_1_POL is set) of the selected interrupt.
18	R/W	0	GPIO_0_IRQ_EDGE: If this bit is 1, then GPIO_0_IRQ generates an interrupt on the rising (or falling edge if GPIO_0_POL is set) of the selected interrupt.
17	R/W	0	GPIO_1_POL: This bit controls the polarity of the GPIO muxed into the GPIO_1 interrupt filter module
16	R/W	0	GPIO_0_POL: This bit controls the polarity of the GPIO muxed into the GPIO_0 interrupt filter module
15	R/W	0	GPIO_1_FILTER_USE_CLK: Setting this bit to 1 connects the input filter to the system clock (the clock used by the media CPU). If this bit is 0, then the filter uses a 125nS clock to filter the GPIO_1 input
14-12	R/W	0	GPIO_1_FILTER_SEL: 0 = no filter, 1 = max filter (about 2.6uS)
11	R/W	0	GPIO_0_FILTER_USE_CLK
10-8	R/W	0	GPIO_0_FILTER_SEL: 0 = no filter, 1 = max filter (about 2.6uS)
7-4	R/W	0	GPIO_1_INPUT_SEL: These bits select which gpioAO[11:0] pin is connected to the GPIO_1 interrupt filter module.
3-0	R/W	0	GPIO_0_INPUT_SEL: These bits select which gpioAO[11:0] pin is connected to the GPIO_1 interrupt filter module.

Table 7-263 GPIO Interrupt EDGE and Polarity: 0x3c20

Bit(s)	R/W	Default	Description
31			GPIO_BOTH_EDGE_PATH_7: If a bit is set to 1, then the GPIO interrupt for GPIO path 7 is configured to be a both edge generated interrupt. and its priority is higher than GPIO_EDGE_SEL_PATH_7.
30			GPIO_BOTH_EDGE_PATH_6:
29			GPIO_BOTH_EDGE_PATH_5:
28			GPIO_BOTH_EDGE_PATH_4:
27			GPIO_BOTH_EDGE_PATH_3:
26			GPIO_BOTH_EDGE_PATH_2:
25			GPIO_BOTH_EDGE_PATH_1:
24			GPIO_BOTH_EDGE_PATH_0:
23			GPIO_POLARITY_PATH_7: If a bit in this field is 1, then the GPIO signal for GPIO interrupt path 7 is inverted.
22			GPIO_POLARITY_PATH_6:
21			GPIO_POLARITY_PATH_5:
20			GPIO_POLARITY_PATH_4:
19			GPIO_POLARITY_PATH_3:

Bit(s)	R/W	Default	Description
18			GPIO_POLARITY_PATH_2:
17			GPIO_POLARITY_PATH_1:
16	R/W	0	GPIO_POLARITY_PATH_0:
15-8	R	0	Unused
7	R/W		GPIO_EDGE_SEL_PATH_7: If a bit is set to 1, then the GPIO interrupt for GPIO path 7 is configured to be an edge generated interrupt. If the polarity (above) is 0, then the interrupt is generated on the rising edge. If the polarity is 1, then the interrupt is generated on the falling edge of the GPIO. If a bit in this field is 0, then the GPIO is a level interrupt.
6	R/W		GPIO_EDGE_SEL_PATH_6
5	R/W		GPIO_EDGE_SEL_PATH_5
4	R/W		GPIO_EDGE_SEL_PATH_4
3	R/W		GPIO_EDGE_SEL_PATH_3
2	R/W		GPIO_EDGE_SEL_PATH_2
1	R/W		GPIO_EDGE_SEL_PATH_1
0	R/W	0	GPIO_EDGE_SEL_PATH_0

Each GPIO interrupt can select from any number of up to 256 GPIO pins on the chip. The bits below control the pin selection for GPIO interrupts 0 ~3.

**Table 7-264 GPIO 0 ~ 3 Pin Select: 0x3c21**

Bit(s)	R/W	Default	Description
31-24	R/W	0	GPIO_PIN_SEL3: This value select which of up to 256 pins on the chip can be mapped to GPIO interrupt 3
23-16	R/W	0	GPIO_PIN_SEL2: This value select which of up to 256 pins on the chip can be mapped to GPIO interrupt 2
15-8	R/W	0	GPIO_PIN_SEL1: This value select which of up to 256 pins on the chip can be mapped to GPIO interrupt 1
7-0	R/W	0	GPIO_PIN_SEL0: This value select which of up to 256 pins on the chip can be mapped to GPIO interrupt 0

**Table 7-265 GPIO 4 ~ 7 Pin Select: 0x3c22**

Bit(s)	R/W	Default	Description
31-24	R/W	0	GPIO_PIN_SEL7: This value select which of up to 256 pins on the chip can be mapped to GPIO interrupt 7
23-16	R/W	0	GPIO_PIN_SEL6: This value select which of up to 256 pins on the chip can be mapped to GPIO interrupt 6
15-8	R/W	0	GPIO_PIN_SEL5: This value select which of up to 256 pins on the chip can be mapped to GPIO interrupt 5
7-0	R/W	0	GPIO_PIN_SEL4: This value select which of up to 256 pins on the chip can be mapped to GPIO interrupt 4

**Table 7-266 GPIO Filter Select (interrupts 0~7): 0x3c23**

Bit(s)	R/W	Default	Description
31	R/W	0	unused
30-28	R/W	0	FILTER_SEL7: (see FILTER_SEL0)
27	R/W	0	Unused
26-24	R/W	0	FILTER_SEL6: (see FILTER_SEL0)
23	R/W	0	Unused
22-20	R/W	0	FILTER_SEL5: (see FILTER_SEL0)
19	R/W	0	Unused
18-16	R/W	0	FILTER_SEL4: (see FILTER_SEL0)
15	R/W	0	Unused
14-12	R/W	0	FILTER_SEL3: (see FILTER_SEL0)
11	R/W	0	Unused
10-8	R/W	0	FILTER_SEL2: (see FILTER_SEL0)
7	R/W	0	Unused
6-4	R/W	0	FILTER_SEL1: (see FILTER_SEL0)
3	R/W	0	unused
2-0	R/W	0	FILTER_SEL0: This value sets the filter selection for GPIO interrupt 0. A value of 0 = no filtering. A value of 7 corresponds to 7 x 3 x (111nS) of filtering.

## 7.11 Timer

### 7.11.1 Overview

The SOC contains 15 general purpose timers and 2 watchdog timers.

### 7.11.2 General-Purpose Timer

The SOC contains a number of general-purpose timers that can be used as general counters or interrupt generators. Each counter (except TIMER E) can be configured as a periodic counter (for generating periodic interrupts) or a simple count-down and stop counter. Additionally, the timers have a programmable count rate ranging from 1uS to 1mS. The table below outlines the general-purpose timers available in the chip.

Timer	Timebase Options	Counter size	Comment
Timer A	1uS, 10uS, 100uS, 1mS	16-bits	The 16-bit counter allows the timer to generate interrupts as infrequent as every 65.535 Seconds
Timer B	1uS, 10uS, 100uS, 1mS	16-bits	
Timer C	1uS, 10uS, 100uS, 1mS	16-bits	
Timer D	1uS, 10uS, 100uS, 1mS	16-bits	
Timer E	System clock, 1uS, 10uS, 100uS, 1mS	64-bits	Doesn't generate an interrupt. This is a count up counter that counts from 0 to 0xFFFFFFFF. The

Timer	Timebase Options	Counter size	Comment
			counter can be written at any time to reset the value to 0.
Timer F	1uS, 10uS, 100uS, 1mS	16-bits	
Timer G	1uS, 10uS, 100uS, 1mS	16-bits	
Timer H	1uS, 10uS, 100uS, 1mS	16-bits	
Timer I	1uS, 10uS, 100uS, 1mS	16-bits	
Timer A-AO	System clock, 1uS, 10uS, 100uS	32-bits	Used in the Always On domain to generate interrupts for the AO-CPU
Timer B-AO	System clock, 1uS, 10uS, 100uS	32-bits	Used in the Always On domain to generate interrupts for the AO-CPU
Timer C-AO	System clock, 1uS, 10uS, 100uS	32-bits	Used in the Always On domain to generate interrupts for the AO-CPU
Timer E-AO	System clock	64-bits	This Always On counter doesn't generate an interrupt. Instead it simply counts up from 0 to 0xFFFFFFFF. The counter can be written at any time to reset the value to 0.
Timer F-AO	System clock	64-bits	This Always On counter doesn't generate an interrupt. Instead it simply counts up from 0 to 0xFFFFFFFF. The counter can be written at any time to reset the value to 0.
Timer G-AO	System clock	64-bits	This Always On counter doesn't generate an interrupt. Instead it simply counts up from 0 to 0xFFFFFFFF. The counter can be written at any time to reset the value to 0.

### 7.11.3 Watchdog Timer

There are also two watchdog timers, one in AO and the other in EE domain, illustrated as following:

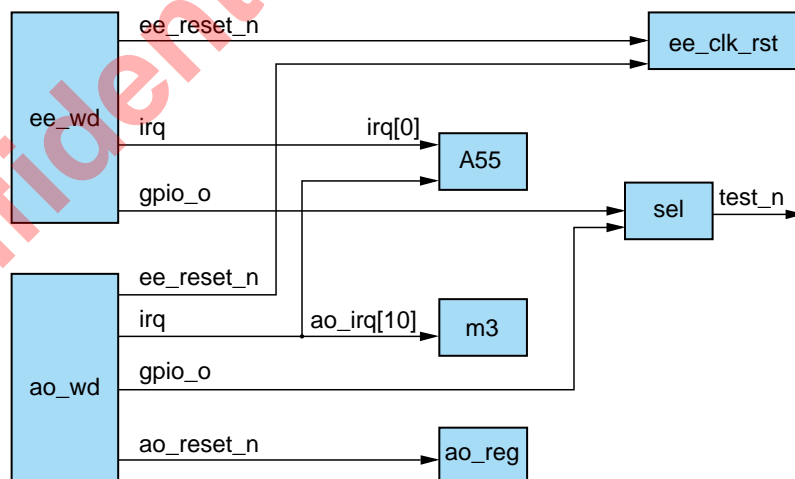

T02FC37

Figure 7-28 EE domain Watchdog Timer Design

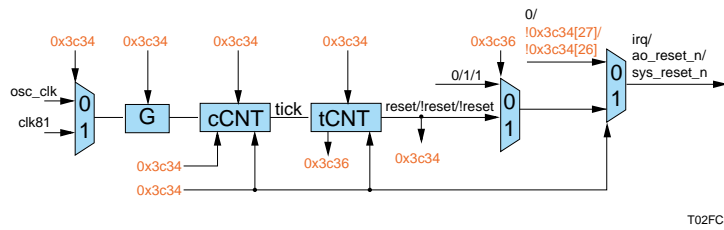

The AO Domain watchdog timer is driven from the system clock (typically 157Mhz). It is a 16-bit counter that is periodically reset by either the AO CPU or the System CPU (A55). This AO-watchdog timer can be used to generate an interrupt of the AO domain. Additionally, the AO-watchdog timer can be used to “enable” a delay generator that can toggle a GPIO pin (currently the TEST\_n I/O pad). The “delay generator” allows an interrupt to first be acknowledged by the AO-CPU before the TEST\_N pad is toggled. The “delay generator” is programmable from 1 to 65535 system clocks (typically 417uS).

It should be noted that the AO watchdog timer can also be used to reset the AO domain but this feature is only used when operating in a suspend mode (only the AO-domain is powered). As long as the system periodically resets the AO-watchdog timer the WD\_GPIO\_CNT (delay generator) will not be enabled and the I/O pad will not toggle.

**Note**

The maximum delay between two AO-watchdog periodic resets is about 100mS (assuming a 157Mhz system clock).

The EE Domain watchdog timer is driven by the 24Mhz crystal clock and can be used to generate an interrupt to the system CPU (the A55) or optionally, the watchdog timer can completely reset the chip (causing a cold boot). There are a few registers that are not affected by watchdog timer. These registers are only reset by the external RESET\_n I/O pad and can be used to store information related to a possible watchdog event. As long as the system CPU periodically resets the EE-watchdog timer, it will never timeout and cause an interrupt or system reset.

**Note**

The maximum delay between two EE-watchdog periodic resets is about 8.3 Seconds. This time is independent of the system clocks and is driven by the external 24Mhz crystal.

**7.11.4 Register Description**

Each register final address = 0xffd00000 + address \* 4

Table 7-267 ISA\_TIMER\_MUX 0x3c50

Bit(s)	R/W	Default	Description
31-20	R	0	unused
19	R/W	1	TIMERD_EN: Set to 1 to enable Timer D
18	R/W	1	TIMERC_EN: Set to 1 to enable Timer C
17	R/W	1	TIMERB_EN: Set to 1 to enable Timer B
16	R/W	1	TIMERA_EN: Set to 1 to enable Timer A
15	R/W	0	TIMERD_MODE: If this bit is set to 1, then timerD is a periodic . 0 = one-shot timer (M1 default)

Bit(s)	R/W	Default	Description
14	R/W	0	TIMERC_MODE: If this bit is set to 1, then timerC is a periodic . 0 = one-shot timer (M1 default)
13	R/W	1	TIMERB_MODE: If this bit is set to 1, then timerB is a periodic (M1 Default). 0 = one-shot timer
12	R/W	1	TIMERA_MODE: If this bit is set to 1, then timerA is a periodic (M1 Default). 0 = one-shot timer
11	R	0	unused
10-8	R/W	0x1	TIMER E input clock selection: 000: System clock 001: 1uS Timebase resolution 010: 10uS Timebase resolution 011: 100uS Timebase resolution 100: 1mS timebase NOTE: The mux selection for Timer E is different from timer A, B, C and D
7-6	R/W	0x0	TIMER D input clock selection: See TIMER A below
5-4	R/W	0x0	TIMER C input clock selection: See TIMER A below
2-3	R/W	0x0	TIMER B input clock selection: See TIMER A below
1-0	R/W	0x0	TIMER A Input clock selection: These bits select the input timebase for the counters for TimerA 00: 1uS Timebase resolution 01: 10uS Timebase resolution 10: 100uS Timebase resolution 11: 1mS Timebase resolution

**Note**

Timer A is a 16 bit count DOWN counter driven by the clock selected in register 0x01000530. TIMER A will count down from some value to zero, generate an interrupt and then re-load the original start count value. This timer can be used to generate a periodic interrupt (e.g. interrupt every 22 uS).

**Table 7-268 ISA\_TIMER A 0x3c51**

Bit(s)	R/W	Default	Description
31-16	R	-	Current Count value
15-0	R/W	0x0	Starting count value. Write this value to start TIMER A.

**Note**

Timer B is just like Timer A.

**Table 7-269 ISA\_TIMER B 0x3c52**

Bit(s)	R/W	Default	Description
31-16	R	-	Current Count value
15-0	R/W	0x0	Starting count value. Write this value to start TIMER B

**Note**

Timer C is just like Timer A.

Table 7-270 ISA\_TIMERC 0x3c53

Bit(s)	R/W	Default	Description
31-16	R	0	unused
15-0	R/W	0x0	Starting count value. Write this value to start TIMER C

**Note**

Timer D is identical to Timer A.

Table 7-271 ISA\_TIMERD 0x3c54

Bit(s)	R/W	Default	Description
31-16	R	0	unused
15-0	R/W	0x0	Starting count value. Write this value to start TIMER C

**Note**

Timer E is simply a 64-bit counter that increments at a rate set by register 0x3c50. To reset the counter to zero, simply write this register with any value. The value below is a read-only value that reflects the current count of the internal counter. This register can be used by software to simply provide a polling delay loop based on a programmable timebase.

Table 7-272 ISA\_TIMERE 0x3c62

Bit(s)	R/W	Default	Description
31-0	R	-	Current value of Timer E. Write this register with any value to clear the counter.

Table 7-273 ISA\_TIMERE\_HI 0x3c63

Bit(s)	R/W	Default	Description
31-0	R	0	Counter[63:32], start by write TIMERE, not write TIMERE_HI.

Table 7-274 ISA\_TIMER\_MUX1 0x3c64

Bit(s)	R/W	Default	Description
31-20	R	0	unused
19	R/W	1	TIMERD_EN: Set to 1 to enable Timer D
18	R/W	1	TIMERC_EN: Set to 1 to enable Timer C
17	R/W	1	TIMERB_EN: Set to 1 to enable Timer B
16	R/W	1	TIMERA_EN: Set to 1 to enable Timer A
15	R/W	0	TIMERD_MODE: If this bit is set to 1, then timerD is a periodic . 0 = one-shot timer (M1 default)
14	R/W	0	TIMERC_MODE: If this bit is set to 1, then timerC is a periodic . 0 = one-shot timer (M1 default)
13	R/W	1	TIMERB_MODE: If this bit is set to 1, then timerB is a periodic (M1 Default). 0 = one-shot timer



Bit(s)	R/W	Default	Description
12	R/W	1	TIMERA_MODE: If this bit is set to 1, then timerA is a periodic (M1 Default). 0 = one-shot timer
11	R	0	unused
10-8	R/W	0x1	TIMER E input clock selection: 000: System clock 001: 1uS Timebase resolution 010: 10uS Timebase resolution 011: 100uS Timebase resolution 100: 1mS timebase NOTE: The mux selection for Timer E is different from timer A, B, C and D
7-6	R/W	0x0	TIMER D input clock selection: See TIMER A below
5-4	R/W	0x0	TIMER C input clock selection: See TIMER A below
2-3	R/W	0x0	TIMER B input clock selection: See TIMER A below
1-0	R/W	0x0	TIMER A Input clock selection: These bits select the input timebase for the counters for TimerA 00: 1uS Timebase resolution 01: 10uS Timebase resolution 10: 100uS Timebase resolution 11: 1mS Timebase resolution

**Note**

Timer F is a 16 bit count DOWN counter driven by the clock selected in register 0x01000530. TIMER A will count down from some value to zero, generate an interrupt and then re-load the original start count value. This timer can be used to generate a periodic interrupt (e.g. interrupt every 22 uS).

**Table 7-275 ISA\_TIMERF 0x3c65**

Bit(s)	R/W	Default	Description
31-16	R	-	Current Count value
15-0	R/W	0x0	Starting count value. Write this value to start TIMER F.

**Note**

Timer G is just like Timer F.

**Table 7-276 ISA\_TIMERG 0x3c66**

Bit(s)	R/W	Default	Description
31-16	R	-	Current Count value
15-0	R/W	0x0	Starting count value. Write this value to start TIMER G

**Note**

Timer H is just like Timer F.

**Table 7-277 ISA\_TIMER\_H 0x3c67**

Bit(s)	R/W	Default	Description
31-16	R	0	unused
15-0	R/W	0x0	Starting count value. Write this value to start TIMER H

**Note**

Timer I is just like Timer F.

**Table 7-278 ISA\_TIMER\_I 0x3c68**

Bit(s)	R/W	Default	Description
31-16	R	0	unused
15-0	R/W	0x0	Starting count value. Write this value to start TIMER I

**Table 7-279 WATCHDOG\_CNTL 0x3c34**

Bit(s)	R/W	Default	Description
31	R	0	Watchdog_reset
30-28	R/W	0	Reserved
27	R/W	0	Ao_reset_n_now, if watchdog_en =0, output ao_reset_n = !ao_reset_n_now
26	R/W	0	Sys_reset_n_now, if watch_dog_en = 0, output sys_reset_n = !sys_reset_n_now.
25	R/W	0	Clk_div_en: 0: no tick; 1: generate tick;
24	R/W	0	Clk_en: 0: no clk; 1: clk work;
23	R/W	0	Interrupt_en: 0: no irq out; 1: irq = watchdog_reset;
22	R/W	0	Ao_reset_n_en: 0: output ao_reset_n = 1; 1: output ao_reset_n = ! watchdog_reset;
21	R/W	0	Sys_reset_n_en 0: output sys_reset_n = 1; 1: output sys_reset_n = ! watchdog_reset;
20	R/W	0	Reserved
19	R/W	0	Clk_sel: 0:osc_clk; 1:clk_81
18	R/W	0	Watchdog_en 0: no watchdog reset 1: gen watchdog reset
17-0	R/W	0	Clk_div_tcmt, when clk_div_en is 1, generate a tick each tcmt clock

**Table 7-280 WATCHDOG\_CNTL1: 0x3c35**

Bit(s)	R/W	Default	Description
31-18	R	0	Reserved
17	R/W	0	Gpio_pulse 0:level reset 1:pulse reset
16	R/W	0	Gpio_polarity 0: 1 is reset; 1: 0 is reset.
15-0	R/W	0	Gpio_pulse_tcmt If gpio_pulse is 1, level reset will hold tcmt clock.

**Table 7-281 WATCHDOG\_TCNT: 0x3c36**

Bit(s)	R/W	Default	Description
31-16	R	0	The cnt of tick.
15-0	R/W	5000	If watchdog_en is 1, when tick cnt reached "5000", generate watchdog_reset.

**Table 7-282 WATCHDOG\_RESET: 0x3c37**

Bit(s)	R/W	Default	Description
31-0	W	0	When write any value(include 0), watchdog module will be reset.

Below registers have the same base address: 0xFF800000, register address: 0xFF800000 + offset \* 4, same for secure and non-secure access

**Table 7-283 AO\_TIMER\_CTRL 0xf0**

Bit(s)	R/W	Default	Description
31-7	R/W	0	Unused
6-5	R/W	0	TIMERE_CLK_MUX: 00 = Timer E clock = Media CPU clock 01 = Timer E clock = 1uS ticks 10 = Timer E clock = 10uS ticks 11 = Timer E clock = 100uS ticks
4	R/W	0	TIMER_E_EN
3	R/W	0	TIMER_A_EN
2	R/W	0	TIMER_A_MODE: 1 = periodic, 0 = one-shot
1-0	R/W	0	TIMERA_CLK_MUX: 00 = TimerA clock = Media CPU clock 01 = Timer A clock = 1uS ticks 10 = Timer A clock = 10uS ticks 11 = Timer A clock = 100uS ticks

**Table 7-284 AO\_TIMER\_SEC\_SCP\_CTRL 0xf1**

Bit(s)	R/W	Default	Description
31-7	R/W	0	Unused
6-5	R/W	0	TIMER F_CLK_MUX: 00 = Timer F clock = Media CPU clock 01 = Timer F clock = 1uS ticks 10 = Timer F clock = 10uS ticks 11 = Timer F clock = 100uS ticks
4	R/W	0	TIMER_F_EN
3	R/W	0	TIMER_B_EN
2	R/W	0	TIMER_B_MODE: 1 = periodic, 0 = one-shot
1-0	R/W	0	TIMERB_CLK_MUX: 00 = TimerB clock = Media CPU clock 01 = Timer B clock = 1uS ticks 10 = Timer B clock = 10uS ticks 11 = Timer B clock = 100uS ticks

**Table 7-285 AO\_TIMER\_SEC\_SP\_CTRL 0xf2**

Bit(s)	R/W	Default	Description
31-7	R/W	0	Unused
6-5	R/W	0	TIMER G_CLK_MUX:

Bit(s)	R/W	Default	Description
			00 = Timer G clock = Media CPU clock 01 = Timer G clock = 1uS ticks 10 = Timer G clock = 10uS ticks 11 = Timer G clock = 100uS ticks
4	R/W	0	TIMER_G_EN
3	R/W	0	TIMER_C_EN
2	R/W	0	TIMER_C_MODE: 1 = periodic, 0 = one-shot
1-0	R/W	0	TIMERC_CLK_MUX: 00 = Timer C clock = Media CPU clock 01 = Timer C clock = 1uS ticks 10 = Timer C clock = 10uS ticks 11 = Timer C clock = 100uS ticks

**Note**

Timer A starts at a non-zero value and decrements to 0. When timer A reaches a count of 0 it will re-load with the TIMER\_A\_TCNT value.

**Table 7-286 AO\_TIMER\_A\_REG 0xf3**

Bit(s)	R/W	Default	Description
31-0	R/W	0	timer A set value; if mode = 0, will clr timer to 0;

**Table 7-287 AO\_TIMER\_A\_CUR\_REG 0xf4**

Bit(s)	R/W	Default	Description
31-0	R	0	TIMER A current count.

**Table 7-288 AO\_TIMER\_B\_REG 0xf5**

Bit(s)	R/W	Default	Description
31-0	R/W	0	timer B set value; if mode = 0, will clr timer to 0;

**Table 7-289 AO\_TIMER\_B\_CUR\_REG 0xf6**

Bit(s)	R/W	Default	Description
31-0	R	0	TIMER B current count.

**Table 7-290 AO\_TIMER\_C\_REG 0xf7**

Bit(s)	R/W	Default	Description
31-0	R/W	0	timer C set value; if mode = 0, will clr timer to 0;

**Table 7-291 AO\_TIMER\_C\_CUR\_REG 0xf8**

Bit(s)	R/W	Default	Description
31-0	R	0	TIMER C current count.

**Note**

If this register is written (with any value), then Timer E is reset to 0. Immediately after being cleared, timer E will start incrementing at a clock rate equal to the clock used for the Media CPU.

**Table 7-292 AO\_TIMERE\_REG 0xf9**

Bit(s)	R/W	Default	Description
31-0	R/W	0	TIMER E current Count[31:0]

**Table 7-293 AO\_TIMERE\_HI\_REG 0xfa**

Bit(s)	R/W	Default	Description
31-0	R/W	0	TIMER E current Count[63:32], latched by read timerE[31:0];

**Note**

If this register is written (with any value), then Timer F is reset to 0. Immediately after being cleared, timer F will start incrementing at a clock rate equal to the clock used for the Media CPU.

**Table 7-294 AO\_TIMERF\_REG 0xfb**

Bit(s)	R/W	Default	Description
31-0	R/W	0	TIMER F current Count[31:0]

**Table 7-295 AO\_TIMERF\_HI\_REG 0xfc**

Bit(s)	R/W	Default	Description
31-0	R/W	0	TIMER F current Count[63:32], latched by read timerF[31:0];

**Note**

If this register is written (with any value), then Timer G is reset to 0. Immediately after being cleared, timer G will start incrementing at a clock rate equal to the clock used for the Media CPU.

**Table 7-296 AO\_TIMERG\_REG 0xfd**

Bit(s)	R/W	Default	Description
31-0	R/W	0	TIMER G current Count[31:0]

**Table 7-297 AO\_TIMERG\_HI\_REG 0xfe**

Bit(s)	R/W	Default	Description
31-0	R/W	0	TIMER G current Count[63:32], latched by read timerG[31:0];

Table 7-298 AO\_WATCHDOG\_CNTL 0x48

Bit(s)	R/W	Default	Description
31-28	R	0	unused
27	R/W	0	Ao_reset_n_now
26	R/W	0	Sys_reset_n_now
25	R/W	0	Clk_div_en
24	R/W	1	Clk_en
23	R/W	0	Interrupt_en
22	R/W	0	Ao_reset_n_en
21	R/W	0	Sys_reset_n_en
20	R/W	0	Noused
19	R/W	0	Clk_sel
18	R/W	0	Watchdog_en
17-0	R/W	23999	Clk_div_tcmt

Table 7-299 AO\_WATCHDOG\_CNTL1 0x49

Bit(s)	R/W	Default	Description
31-17	R	0	unused
17	R/W	0	Gpio_pulse
16	R/W	0	Gpio_polarity
15-0	R/W	0	Gpio_pulse_tcmt

Table 7-300 AO\_WATCHDOG\_TCNT 0x4a

Bit(s)	R/W	Default	Description
31-16	R	0	Watchdog count read
15-0	R/W	0	Watchdog_count set

**Note**

Write any value can reset watchdog.

Table 7-301 AO\_WATCHDOG\_RESET 0x4b

Bit(s)	R/W	Default	Description
31-0	W	0	Watchdog soft reset

**Note**

Write any value can reset watchdog.

Table 7-302 AO\_RTI\_STICKY\_REG0~3 0x4c~0x4f

Bit(s)	R/W	Default	Description
31-0	W	0	

## 7.12 Crypto

### 7.12.1 Overview

The crypto engine is one encrypt/decrypt function accelerator. Crypto engine supports 4 different modes, i.e. A55 secure, A55 non secure, M3 secure and M3 non secure. The crypto engine has special internal DMA controller to transfer data.

It has the following features.

- Trustzone based Trusted Execution Environment (TEE)
- Secured boot, encrypted OTP, encrypted DRAM with memory integrity checker, hardware key ladder and internal control buses and storage
- Separated secure/non-secure Entropy true RNG
- Pre-region/ID memory security control and electric fence
- Hardware based Trusted Video Path (TVP) , video watermarking and secured contents (needs SecureOS software)
- Secured IO and secured clock

### 7.12.2 Key Ladder

The Key Ladder is a series of TDES / AES crypto processes that iterates on different user supplied and OTP keys. The key ladder module uses a single AES / TDES crypto module and iterates by using internal storage to hold temporary states.

### 7.12.3 RNG

Functionality the Random Number Generator (RNG) contains two main modules, True Random Number Generator (TRNG) and Deterministic Random Number Generator (DRNG).

- True Random Number Generator (TRNG): is realized by using metastability and jitter for random bit generation based on four free running ring oscillator
- Deterministic Random Number Generator (DRNG): which has 32-bit random number generator, is mainly designed to increase the throughput and do post-processing of the Digital TRNG, which will need hundreds cycles to collect entropy.

### 7.12.4 EFUSE

The EFUSE consists of a 4k bit One Time Programmable (OTP) memory that is broken up into 32, 128-bit blocks. Data is always read/written in 128-bit blocks using the APB bus (software) or by the Key-ladder which is integrated with EFUSE block.

# 8 GE2D

## 8.1 Overview

The basic structure of GE2D is shown in figure below.

Figure 8-1 GE2D Structure

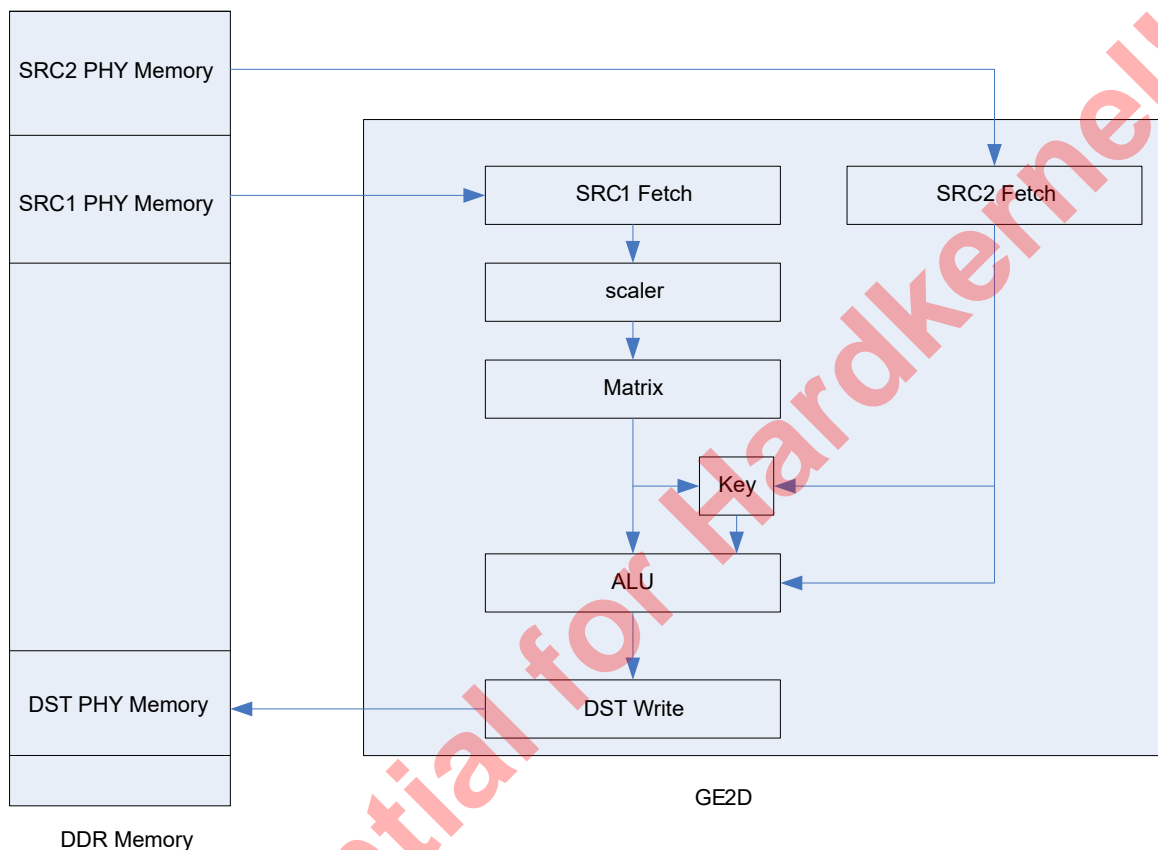

T02ST07

## 8.2 Register Description

Table 8-1 GE2D\_GEN\_CTRL0 0x8A0

Bit(s)	R/W	Default	Description
31	R/W	0	dst_bytemask_only: Applicable only if dst_bitmask_en=1.
30	R/W	0	dst_bitmask_en: destination bitmask enable. 0: disable; 1: enable.
29	R/W	0	src2_key_en: source2 key enable. 0: disable; 1: enable.
28	R/W	0	src2_key_mode: source2 key mode. 0: mask data when match; 1: mask data when unmatched.



Bit(s)	R/W	Default	Description
27	R/W	0	src1_key_en: source1 key enable. 0: disable; 1: enable.
26	R/W	0	src1_key_mode: source1 key mode. 0: mask data when match; 1: mask data when unmatched.
25-24	R/W	0	dst1_8b_mode_sel: Destination 1's 8-bit mode component selection. 0: Select Y or R; 1: Select Cb or G; 2: Select Cr or B; 3: Select Alpha.
23	R/W	0	dst_clip_mode: 0: Write inside clip window; 1: Write outside clip window.
22-17	R	0	Unused
16-15	R/W	0	src2_8b_mode_sel: Applicable only when src2_format=0, define the property of the 8-bit output data. 0: The 8-bit output data is for Y or R; 1: The 8-bit output data is for Cb or G; 2: The 8-bit output data is for Cr or B; 3: The 8-bit output data is for Alpha.
14	R/W	0	src2_fill_mode: When the display window is outside the boundary of the clipping window, this field defines how to fill the area outside the clipping window. 0: Fill with the pixels at the boundary of the clipping window; 1: Fill with the default color defined by register GE2D_SRC2_DEF_COLOR.
13-12	R/W	0	src2_pic_struct: Define how source2 reads the picture stored in DDR memory. 0: Read all lines; 1: Reserved; 2: Read even lines only; 3: Read odd lines only.
11	R/W	0	src2_X_yc_ratio: Source2 x direction yc ratio. 0: 1:1; 1: 2:1.
9-7	R	0	Unused
6-5	R/W	0	src1_8b_mode_sel: Applicable only when src1_sep_en =0, src1_format=0 and src1_lut_en=0, define the property of the 8-bit output data. 0: the 8-bit output data is for Y or R; 1: the 8-bit output data is for Cb or G; 2: the 8-bit output data is for Cr or B; 3: the 8-bit output data is for Alpha.
4	R/W	0	src1_fill_mode: When the display window is outside the boundary of the clipping window, this field defines how to fill the area outside the clipping window. 0: Fill with the pixels at the boundary of the clipping window; 1: Fill with the default color defined by register GE2D_SRC1_DEF_COLOR.
3	R/W	0	src1_lut_en: Applicable only when src1_sep_en =0 and src1_format= 0, define whether to enable 8-bit input data to look up a 32-bit pixel for output. 0: Disable; 1: Enable.
2-1	R/W	0	src1_pic_struct: Define how source1 reads the picture stored in DDR memory. 0: Read all lines; 1: Reserved; 2: Read even lines only; 3: Read odd lines only.

Table 8-2 GE2D\_GEN\_CTRL1 0x8A1

Bit(s)	R/W	Default	Description
31	R/W	0	soft_rst: If true, reset GE2D.
30	R/W	0	dst write response counter reset
29	R/W	0	disable adding dst write response count to busy bit
28-27	R	0	Unused
26	R/W	0	Color_conversion_mode[1] in alu. Mode[1:0] 3 : color_out = color; 2 : color_out = (color != 255) ? color : color + 1; 1 : color_out = (color < 128) ? color : color + 1; 0 : color_out = (color == 0) ? color : color + 1.
25-24	R/W	0	interrupt_ctrl: If bit[0] true, generate interrupt when one command done; if bit[1] true, generate interrupt when ge2d change from busy to not busy.
23-22	R/W	0x3	src2_burst_size_ctrl: Source2 DDR request burst size control. (Note: data to source2 are stored together in one DDR memory block.) 0: Burst size = 24 x 64-bit; 1: Burst size = 32 x 64-bit; 2: Burst size = 48 x 64-bit; 3: Burst size = 64 x 64-bit.
21-16	R/W	0x3F	src1_burst_size_ctrl: Source1 DDR request burst size control. Bit[21:20] control Y burst size, bit[19:18] control Cb burst size, bit[17:16] control Cr burst size. Each 2-bit is decoded as below: 0: Burst size = 24 x 64-bit; 1: Burst size = 32 x 64-bit; 2: Burst size = 48 x 64-bit; 3: Burst size = 64 x 64-bit.
15-14	R/W	0	dst1_pic_struct: Define how destination 1 write the picture to DDR memory. 0: Write all lines (whole frame); 1: Reserved; 2: Write even lines only (top); 3: Write odd lines only (bottom).
13-12	R/W	0	src_rd_ctrl: Bit[13] if true, force read src1, bit[12] if true, force read src2.
11	R/W	0	dst2_urgent_en: Destination 2 DDR request urgent enable.
10	R/W	0	src1_urgent_en: Source1 DDR request urgent enable.
9	R/W	0	src2_urgent_en: Source2 DDR request urgent enable.
8	R/W	0	dst1_urgent_en: Destination 1 DDR request urgent enable.
7-0	R/W	0	src1_gb_alpha: Source1 global alpha.

Table 8-3 GE2D\_GEN\_CTRL2 0x8A2

Bit(s)	R/W	Default	Description
31	R/W	0	alpha_conversion_mode[0] in alu. Mode[1:0]: 2,3 : alpha_out = (alpha!=255) ? alpha : alpha + 1; 1 : alpha_out = (alpha < 128) ? alpha : alpha + 1; 0 : alpha_out = (alpha == 0) ? alpha : alpha + 1.
30	R/W	0	Color_conversion_mode[0] in alu. Mode[1:0] 3 : color_out = color; 2 : color_out = (color != 255) ? color : color + 1; 1 : color_out = (color < 128) ? color : color + 1;

Bit(s)	R/W	Default	Description
			0 : color_out = (color == 0) ? color : color + 1.
29	R/W	0	src1_gb_alpha_en in alu. As = src1_gb_alpha_en ? Asr * Ag : Asr
28	R/W	0	dst1_COLOR_round_MODE. 1 = Truncate the full bit color components to required output bit width; 0 = Round (+ 0.5) the full bit color components to required output bit width.
27	R/W	0	src2_COLOR_EXPAND_MODE. 1 = Expand the color components to 8-bit by padding LSBs with MSBs. E.g. If the input is 5'b11000, the output is expanded to 8'b11000110; 0 = Expand the color components to 8-bit by padding LSBs with 0.
26	R/W	0	src2_ALPHA_EXPAND_MODE. 1 = Expand alpha value to 8-bit by padding LSBs with MSBs. E.g. If the input is 5'b11000, the output is expanded to 8'b11000110; 0 = If input alpha value is all 1, then expand the value to 8-bit by padding LSBs with 1; otherwise, pad LSBs with 0.
25	R/W	0	src1_COLOR_EXPAND_MODE. 1 = Expand the color components to 8-bit by padding LSBs with MSBs. E.g. If the input is 5'b11000, the output is expanded to 8'b11000110; 0 = Expand the color components to 8-bit by padding LSBs with 0.
24	R/W	0	src1_ALPHA_EXPAND_MODE. 1 = Expand alpha value to 8-bit by padding LSBs with MSBs. E.g. If the input is 5'b11000, the output is expanded to 8'b11000110; 0 = If input alpha value is all 1, then expand the value to 8-bit by padding LSBs with 1; otherwise, pad LSBs with 0.
23	R/W	0	dst_little_endian: define the endianness of SRC2 input data. 1 = Little endian; 0 = Big endian.
22-19	R/W	0	dst1_color_map: Applicable to 16-bit, 24-bit and 32-bit pixel, defines the bit-field allocation of the pixel data. For whether to truncate or round full 8-bit to output, refer to ge2d_gen_ctrl2.dst1_color_round_mode.  For 16-bit mode (dst1_format=1): 0 = Unused; 1 = 6:5:5 format. Bit[15:10] is Y[7:2] or R[7:2], bit[9:5] is Cb[7:3] or G[7:3], bit[4:0] is Cr[7:3] or B[7:3]; 2 = 8:4:4 format. Bit[15:8] is Y or R, bit[7:4] is Cb[7:4] or G[7:4], bit[3:0] is Cr[7:4] or B[7:4]; 3 = 6:4:4:2 format. Bit[15:10] is Y[7:2] or R[7:2], bit[9:6] is Cb[7:4] or G[7:4], bit [5:2] is Cr[7:4] or B[7:4], bit[1:0] is Alpha[7:6]; 4 = 4:4:4:4 format. Bit[15:12] is Y[7:4] or R[7:4], bit[11:8] is Cb[7:4] or G[7:4], bit [7:4] is Cr[7:4] or B[7:4], bit[3:0] is Alpha[7:4]; 5 = 5:6:5 format. Bit[15:11] is Y[7:3] or R[7:3], bit[10:5] is Cb[7:2] or G[7:2], bit [4:0] is Cr[7:3] or B[7:3]; 6 = 4:4:4:4 format. Bit[15:12] is Alpha[7:4], bit[11:8] is Y[7:4] or R[7:4], bit[7:4] is Cb[7:4] or G[7:4], bit[3:0] is Cr[7:4] or B[7:4]; 7 = 1:5:5:5 format. Bit[15] is Alpha[7], bit[14:10] is Y[7:3] or R[7:3], bit[9:5] is Cb [7:3] or G[7:3], bit[4:0] is Cr[7:3] or B[7:3]; 8 = 4:6:4:2 format. Bit[15:12] is Y[7:4] or R[7:4], bit[11:6] is Cb[7:2] or G[7:2], bit [5:2] is Cr[7:4] or B[7:4], bit[1:0] is Alpha[1:0]. 9 = CbCr format. Bit[15:8] is Cb, bit[7:0] is Cr; 10 = CrCb format. Bit[15:8] is Cr, bit[7:0] is Cb.  For 24-bit mode (dst1_format=2): 0 = RGB 8:8:8 mode. Bit[23:16] is Y or R, bit[15:8] is Cb or G, bit[7:0] is Cr or B; 1 = RGBA 5:6:5:8 mode. Bit[23:19] is Y[7:3] or R[7:3], bit[18:13] is Cb[7:2] or G [7:2], bit[12:8] is Cr[7:3] or B[7:3], bit[7:0] is Alpha; 2 = ARGB 8:5:6:5 mode. Bit[23:16] is Alpha, bit[15:11] is Y[7:3] or R[7:3], bit [10:5] is Cb[7:2] or G[7:2], bit[4:0] is Cr[7:3] or B[7:3]; 3 = RGBA 6:6:6:6 mode. Bit[23:18] is Y[7:2] or R[7:2], bit[17:12] is Cb[7:2] or G [7:2], bit[11:6] is Cr[7:2] or B[7:2], bit[5:0] is Alpha[7:2];

Bit(s)	R/W	Default	Description
			<p>4 = ARGB 6:6:6:6 mode. Bit[23:18] is Alpha[7:2];, bit[17:12] is Y[7:2] or R[7:2], bit[11:6] is Cb[7:2] or G[7:2], bit[5:0] is Cr[7:2] or B[7:2];            5 = BGR 8:8:8 mode. Bit[23:16] is Cr or B, bit[15:8] is Cb or G, bit[7:0] is Y or R.</p> <p>For 32-bit mode (dst1_format=3):            0 = RGBA 8:8:8:8 format. Bit[31:24] is Y or R, bit[23:16] is Cb or G; bit[15:8] is Cr or B; bit[7:0] is Alpha;            1 = ARGB 8:8:8:8 format. Bit[31:24] is Alpha, bit[23:16] is Y or R; bit[15:8] is Cb or G; bit[7:0] is Cr or B;            2 = ABGR 8:8:8:8 format. Bit[31:24] is Alpha, bit[23:16] is Cr or B; bit[15:8] is Cb or G; bit[7:0] is Y or R;            3 = BGRA 8:8:8:8 format. Bit[31:24] is Cr or B, bit[23:16] is Cb or G; bit[15:8] is Y or R; bit[7:0] is Alpha.</p>
18	R/W	0	<p>ALU_MULT_MODE:            1: mult result rounding else truncation</p>
17-16	R/W	0	<p>dst1_format: define output pixel byte-width.            0: Output pixel is 1-byte (8-bit) color component;            1: Output pixel is 2-byte (16-bit), refer to GE2D_GEN_CTRL2.dst1_COLOR_MAP for further pixel color mapping;            2: Output pixel is 3-byte (24-bit), refer to GE2D_GEN_CTRL2.dst1_COLOR_MAP for further pixel color mapping;            3: Output pixel is 4-byte (32-bit), refer to GE2D_GEN_CTRL2.dst1_COLOR_MAP for further pixel color mapping.</p>
15	R/W	0	<p>src2_little_endian: define the endianness of SRC2 input data.            1 = Little endian;            0 = Big endian.</p>
14-11	R/W	0	<p>src2_color_map: Applicable to 16-bit, 24-bit and 32-bit pixel, defines the bit-field allocation of the pixel data. For expanding the bit-fields to full 8-bit, refer to ge2d_gen_ctrl2.src2_color_expand_mode and ge2d_gen_ctrl2.src2_alpha_expand_mode.</p> <p>For 16-bit mode (src2_format=1):            0 = Unused;            1 = 6:5:5 format. Bit[15:10] is Y[7:2] or R[7:2], bit[9:5] is Cb[7:3] or G[7:3], bit[4:0] is Cr[7:3] or B[7:3], for Alpha value refer to src2_def_color_alpha 0x8af[7:0];            2 = 8:4:4 format. Bit[15:8] is Y or R, bit[7:4] is Cb[7:4] or G[7:4], bit[3:0] is Cr[7:4] or B[7:4], for Alpha value refer to src2_def_color_alpha 0x8af[7:0];            3 = 6:4:4:2 format. Bit[15:10] is Y[7:2] or R[7:2], bit[9:6] is Cb[7:4] or G[7:4], bit[5:2] is Cr[7:4] or B[7:4], bit[1:0] is Alpha[7:6];            4 = 4:4:4:4 format. Bit[15:12] is Y[7:4] or R[7:4], bit[11:8] is Cb[7:4] or G[7:4], bit[7:4] is Cr[7:4] or B[7:4], bit[3:0] is Alpha[7:4];            5 = 5:6:5 format. Bit[15:11] is Y[7:3] or R[7:3], bit[10:5] is Cb[7:2] or G[7:2], bit[4:0] is Cr[7:3] or B[7:3], for Alpha value refer to src2_def_color_alpha 0x8af[7:0];            6 = 4:4:4:4 format. Bit[15:12] is Alpha[7:4], bit[11:8] is Y[7:4] or R[7:4], bit[7:4] is Cb[7:4] or G[7:4], bit[3:0] is Cr[7:4] or B[7:4];            7 = 1:5:5:5 format. Bit[15] is Alpha[7], bit[14:10] is Y[7:3] or R[7:3], bit[9:5] is Cb[7:3] or G[7:3], bit[4:0] is Cr[7:3] or B[7:3];            8 = 4:6:4:2 format. Bit[15:12] is Y[7:4] or R[7:4], bit[11:6] is Cb[7:2] or G[7:2], bit[5:2] is Cr[7:4] or B[7:4], bit[1:0] is Alpha[1:0].</p> <p>For 24-bit mode (src2_format=2):            0 = RGB 8:8:8 mode. Bit[23:16] is Y or R, bit[15:8] is Cb or G, bit[7:0] is Cr or B, for Alpha value refer to src2_def_color_alpha 0x8af[7:0];            1 = RGBA 5:6:5:8 mode. Bit[23:19] is Y[7:3] or R[7:3], bit[18:13] is Cb[7:2] or G[7:2], bit[12:8] is Cr[7:3] or B[7:3], bit[7:0] is Alpha;            2 = ARGB 8:5:6:5 mode. Bit[23:16] is Alpha, bit[15:11] is Y[7:3] or R[7:3], bit[10:5] is Cb[7:2] or G[7:2], bit[4:0] is Cr[7:3] or B[7:3];            3 = RGBA 6:6:6:6 mode. Bit[23:18] is Y[7:2] or R[7:2], bit[17:12] is Cb[7:2] or G[7:2], bit[11:6] is Cr[7:2] or B[7:2], bit[5:0] is Alpha[7:2];            4 = ARGB 6:6:6:6 mode. Bit[23:18] is Alpha[7:2];, bit[17:12] is Y[7:2] or R[7:2], bit[11:6] is Cb[7:2] or G[7:2], bit[5:0] is Cr[7:2] or B[7:2];            5 = BGR 8:8:8 mode. Bit[23:16] is Cr or B, bit[15:8] is Cb or G, bit[7:0] is Y or R, for Alpha value refer to src2_def_color_alpha 0x8af[7:0].</p>

Bit(s)	R/W	Default	Description
			<p>For 32-bit mode (src2_format=3):            0 = RGBA 8:8:8:8 format. Bit[31:24] is Y or R, bit[23:16] is Cb or G; bit[15:8] is Cr or B; bit[7:0] is Alpha;            1 = ARGB 8:8:8:8 format. Bit[31:24] is Alpha, bit[23:16] is Y or R; bit[15:8] is Cb or G; bit[7:0] is Cr or B;            2 = ABGR 8:8:8:8 format. Bit[31:24] is Alpha, bit[23:16] is Cr or B; bit[15:8] is Cb or G; bit[7:0] is Y or R;            3 = BGRA 8:8:8:8 format. Bit[31:24] is Cr or B, bit[23:16] is Cb or G; bit[15:8] is Y or R; bit[7:0] is Alpha.</p>
10	R/W	0	<p>alpha_conversion_mode[1] in alu.            Mode[1:0]:            2,3 : alpha_out = (alpha!=255) ? alpha : alpha + 1;            1 : alpha_out = (alpha &lt; 128) ? alpha : alpha + 1;            0 : alpha_out = (alpha == 0) ? alpha : alpha + 1.</p>
9-8	R/W	0	<p>src2_format: define input pixel byte-width.            0: Input pixel is 1-byte (8-bit) color component;            1: Input pixel is 2-byte (16-bit), refer to GE2D_GEN_CTRL2.SRC2_COLOR_MAP for further pixel color mapping;            2: Input pixel is 3-byte (24-bit), refer to GE2D_GEN_CTRL2.SRC2_COLOR_MAP for further pixel color mapping;            3: Input pixel is 4-byte (32-bit), refer to GE2D_GEN_CTRL2.SRC2_COLOR_MAP for further pixel color mapping.</p>
7	R/W	0	<p>src1_little_endian: define the endianness of SRC1 input data.            1 = Little endian;            0 = Big endian.</p>
6-3	R/W	0	<p>src1_color_map:            Note: If SRC1_DEEPCOLOR=0, the SRC1_COLOR_MAP's definitions is as below.            If SRC1_DEEPCOLOR=1, please refer to SRC1_DEEPCOLOR entry for new meaning.</p> <p>Applicable to 16-bit, 24-bit and 32-bit pixel, defines the bit-field allocation of the pixel data. For expanding the bit-fields to full 8-bit, refer to ge2d_gen_ctrl2.src1_color_expand_mode and ge2d_gen_ctrl2.src1_alpha_expand_mode.</p> <p>For 16-bit mode (src1_format=1):            0 = 4:2:2 format (Y0Cb0Y1Cr0);            1 = 6:5:5 format. Bit[15:10] is Y[7:2] or R[7:2], bit[9:5] is Cb[7:3] or G[7:3], bit[4:0] is Cr[7:3] or B[7:3], for Alpha value refer to src1_def_color_alpha 0x8a6[7:0];            2 = 8:4:4 format. Bit[15:8] is Y or R, bit[7:4] is Cb[7:4] or G[7:4], bit[3:0] is Cr[7:4] or B[7:4], for Alpha value refer to src1_def_color_alpha 0x8a6[7:0];            3 = 6:4:4:2 format. Bit[15:10] is Y[7:2] or R[7:2], bit[9:6] is Cb[7:4] or G[7:4], bit [5:2] is Cr[7:4] or B[7:4], bit[1:0] is Alpha[7:6];            4 = 4:4:4:4 format. Bit[15:12] is Y[7:4] or R[7:4], bit[11:8] is Cb[7:4] or G[7:4], bit [7:4] is Cr[7:4] or B[7:4], bit[3:0] is Alpha[7:4];            5 = 5:6:5 format. Bit[15:11] is Y[7:3] or R[7:3], bit[10:5] is Cb[7:2] or G[7:2], bit [4:0] is Cr[7:3] or B[7:3], for Alpha value refer to src1_def_color_alpha 0x8a6 [7:0];            6 = 4:4:4:4 format. Bit[15:12] is Alpha[7:4], bit[11:8] is Y[7:4] or R[7:4], bit[7:4] is Cb[7:4] or G[7:4], bit[3:0] is Cr[7:4] or B[7:4];            7 = 1:5:5:5 format. Bit[15] is Alpha[7], bit[14:10] is Y[7:3] or R[7:3], bit[9:5] is Cb [7:3] or G[7:3], bit[4:0] is Cr[7:3] or B[7:3];            8 = 4:6:4:2 format. Bit[15:12] is Y[7:4] or R[7:4], bit[11:6] is Cb[7:2] or G[7:2], bit [5:2] is Cr[7:4] or B[7:4], bit[1:0] is Alpha[1:0].</p> <p>For 24-bit mode (src1_format=2):            0 = RGB 8:8:8 mode. Bit[23:16] is Y or R, bit[15:8] is Cb or G, bit[7:0] is Cr or B, for Alpha value refer to src1_def_color_alpha 0x8a6[7:0];            1 = RGBA 5:6:5:8 mode. Bit[23:19] is Y[7:3] or R[7:3], bit[18:13] is Cb[7:2] or G [7:2], bit[12:8] is Cr[7:3] or B[7:3], bit[7:0] is Alpha;            2 = ARGB 8:5:6:5 mode. Bit[23:16] is Alpha, bit[15:11] is Y[7:3] or R[7:3], bit [10:5] is Cb[7:2] or G[7:2], bit[4:0] is Cr[7:3] or B[7:3];</p>

Bit(s)	R/W	Default	Description
			<p>3 = RGBA 6:6:6:6 mode. Bit[23:18] is Y[7:2] or R[7:2], bit[17:12] is Cb[7:2] or G[7:2], bit[11:6] is Cr[7:2] or B[7:2], bit[5:0] is Alpha[7:2];</p> <p>4 = ARGB 6:6:6:6 mode. Bit[23:18] is Alpha[7:2];, bit[17:12] is Y[7:2] or R[7:2], bit[11:6] is Cb[7:2] or G[7:2], bit[5:0] is Cr[7:2] or B[7:2];</p> <p>5 = BGR 8:8:8 mode. Bit[23:16] is Cr or B, bit[15:8] is Cb or G, bit[7:0] is Y or R, for Alpha value refer to src1_def_color_alpha 0x8a6[7:0].</p> <p>14=NV12 format. 8-bit Y and 16-bit CbCr;</p> <p>15=NV21 format. 8-bit Y and 16-bit CrCb;</p> <p>For 32-bit mode (src1_format=3):</p> <p>0 = RGBA 8:8:8:8 format. Bit[31:24] is Y or R, bit[23:16] is Cb or G; bit[15:8] is Cr or B; bit[7:0] is Alpha;</p> <p>1 = ARGB 8:8:8:8 format. Bit[31:24] is Alpha, bit[23:16] is Y or R; bit[15:8] is Cb or G; bit[7:0] is Cr or B;</p> <p>2 = ABGR 8:8:8:8 format. Bit[31:24] is Alpha, bit[23:16] is Cr or B; bit[15:8] is Cb or G; bit[7:0] is Y or R;</p> <p>3 = BGRA 8:8:8:8 format. Bit[31:24] is Cr or B, bit[23:16] is Cb or G; bit[15:8] is Y or R; bit[7:0] is Alpha.</p>
2	R/W	0	<p>src1_DEEPCOLOR:</p> <p>1 = Enable deepcolor formats support, the formats are defined by SRC1_FORMAT and SRC1_COLOR_MAP;</p> <p>0 = Disable deepcolor.</p> <p>The supported deepcolor formats are as below:</p> <p>src1_deep_color=1, src1_format=2'b01, src1_color_map=4'b0000 or 4'b0001: 10-bit 422 in one canvas – 10-bit Y + 10-bit C = 20-bit per pixel in canvas. If src1_color_map=4'b0000, the sequence is Y0Cb0, Y1Cr0, ... If src1_color_map=4'b0001, the sequence is Y0Cr0, Y1Cb0, ...</p> <p>src1_deep_color=1, src1_format=2'b01, src1_color_map=4'b1000 or 4'b1001: 12-bit 422 in one canvas – 12-bit Y + 12-bit C = 24-bit per pixel in canvas. If src1_color_map=4'b1000, the sequence is Y0Cb0, Y1Cr0, ... If src1_color_map=4'b1001, the sequence is Y0Cr0, Y1Cb0, ...</p> <p>src1_deep_color=1, src1_format=2'b10: 10-bit 444 in one canvas – 10-bit Y + 10-bit Cb + 10-bit Cr + 2-bit stuffing = 32-bit per pixel in canvas. If src1_color_map=4'b0000, the sequence is Y0Cb0Cr0, Y1Cb1Cr1, ... If src1_color_map=other value, the sequence is Cr0Cb0Y0, Cr1Cb1Y1, ...</p>
1-0	R/W	0	<p>src1_format: define input pixel byte-width.</p> <p>Note: If SRC1_DEEPCOLOR=0, the SRC1_FORMAT's definitions is as below. If SRC1_DEEPCOLOR=1, please refer to SRC1_DEEPCOLOR entry for new meaning.</p> <p>0: Input pixel is 1-byte (8-bit), it is either an 8-bit color component or 8-bit address to look up a 32-bit pixel, refer to GE2D_GEN_CTRL0.src1_lut_en</p> <p>1: Input pixel is 2-byte (16-bit), refer to GE2D_GEN_CTRL2.SRC1_COLOR_MAP for further pixel color mapping;</p> <p>2: Input pixel is 3-byte (24-bit), refer to GE2D_GEN_CTRL2.SRC1_COLOR_MAP for further pixel color mapping;</p> <p>3: Input pixel is 4-byte (32-bit), refer to GE2D_GEN_CTRL2.SRC1_COLOR_MAP for further pixel color mapping.</p>

Table 8-4 GE2D\_CMD\_CTRL 0x8A3

Bit(s)	R/W	Default	Description
31-10	R	0	unused
9	R/W	0	src2_fill_color_en: if true, all src2 data use default color.
8	R/W	0	src1_fill_color_en: if true, all src1 data use default color.
7	R/W	0	dst_xy_swap: if true, dst x/y swap.

Bit(s)	R/W	Default	Description
6	R/W	0	dst_x_rev: if true, dst x direction reversely read.
5	R/W	0	dst_y_rev: if true, dst y direction reversely read.
4	R/W	0	src2_x_rev: if true, src2 x direction reversely read.
3	R/W	0	src2_y_rev: if true, src2 y direction reversely read.
2	R/W	0	src1_x_rev: if true, src1 x direction reversely read.
1	R/W	0	src1_y_rev: if true, src1 y direction reversely read.
0	R/W	0	cbus_cmd_wr: If true, generate a pulse to validate a GE2D command, the command is described by the rest of the field of this register.

Table 8-5 GE2D\_STATUS0 0x8A4

Bit(s)	R/W	Default	Description
31-29	R	0	unused
28-17	R	0	dst write response counter, for debug only.
16-7	R	0	dp_status: ge2d_dp status, for debug only.
6	R	0	r1cmd_rdy: read src2 cmd ready.
5	R	0	r2cmd_rdy: read src2 cmd ready.
4	R	0	pdpcmd_v: pre dpcmd ready.
3	R	0	dpcmd_rdy: GE2D dpcmd ready.
2	R	0	buf_cmd_v: GE2D buffer command valid.
1	R	0	curr_cmd_v: GE2D current command valid.
0	R	0	ge2d_busy: GE2D busy.

Table 8-6 GE2D\_STATUS1 0x8A5

Bit(s)	R/W	Default	Description
31-30	R	0	unused
29-16	R	0	ge2d_dst1_status, for debug only.
15	R	1	ge2d_rd_src2 core.fifo_empty.
14	R	0	ge2d_rd_src2 core.fifo_overflow.
13-12	R	0	ge2d_rd_src2 core.req_st. Same as req_st_y.
11	R	0	ge2d_rd_src2 cmd_if.cmd_err, true if cmd_format=1.
10	R	0	ge2d_rd_src2 cmd_if.cmd_st, 0=IDLE state, 1=BUSY state.
9	R	1	ge2d_rd_src1 luma_core(chroma_core).fifo_empty.
8	R	0	ge2d_rd_src1 luma_core(chroma_core).fifo_overflow.
7-6	R	0	ge2d_rd_src1 chroma_core.req_st_cr. Same as req_st_y.
5-4	R	0	ge2d_rd_src1 chroma_core.req_st_cb. Same as req_st_y.

Bit(s)	R/W	Default	Description
3-2	R	0	ge2d_rd_src1 luma_core.req_st_y. 0: IDLE; 1: WAIT_FIFO_ROOM; 2: REQUEST; 3: WAIT_FINISH.
1	R	0	ge2d_rd_src1 cmd_if.stat_read_window_err, 1=reading/clipping window setting exceed limit.
0	R	0	ge2d_rd_src1 cmd_if.cmd_st, 0=IDLE state, 1=BUSY state.

Table 8-7 GE2D\_SRC1\_DEF\_COLOR 0x8A6

Bit(s)	R/W	Default	Description
31-24	R/W	0	Default Y or R.
23-16	R/W	0x80	Default Cb or G.
15-8	R/W	0x80	Default Cr or B.
7-0	R/W	0	Default Alpha.

Table 8-8 GE2D\_SRC1\_CLIPX\_START\_END 0x8A7

Bit(s)	R/W	Default	Description
31	R/W	0	SRC1 clip x start extra, if true, one more data is read for chroma.
30-29	R	0	Unused.
28-16	R/W	0	SRC1 clip x start.
15	R/W	0	SRC1 clip x end extra, if true, one more data is read for chroma.
14-13	R	0	Unused.
12-0	R/W	0x1FFF	SRC1 clip x end.

Table 8-9 GE2D\_SRC1\_CLIPY\_START\_END 0x8A8

Bit(s)	R/W	Default	Description
30-29	R	0	Unused.
28-16	R/W	0	SRC1 clip y start.
14-13	R	0	Unused.
12-0	R/W	0x1FFF	SRC1 clip y end.

Table 8-10 GE2D\_SRC1\_CANVAS 0x8A9

Bit(s)	R/W	Default	Description
31-24	R/W	0	SRC1 canvas address0, for Y only or Y/Cb/Cr stored together.
7-0	R	0	Unused.



**Table 8-11 GE2D\_SRC1\_X\_START\_END 0x8AA**

Bit(s)	R/W	Default	Description
31	R/W	0	SRC1 x start extra bit1, if true, one more chroma data is read for x even start chroma data when y/c ratio = 2 or x even/odd start chroma extra data when y/c ratio = 1
30	R/W	0	SRC1 x start extra bit0, if true, one more chroma data is read for x odd start chroma data when y/c ratio = 2
29-16	R/W	0	SRC1 x start, signed data
15	R/W	0	SRC1 x end extra bit1, if true, one more chroma data is read for x odd end chroma data when y/c ratio = 2 or x even/odd end chroma extra data when y/c ratio = 1
14	R/W	0	SRC1 x end extra bit0, if true, one more chroma data is read for x even end chroma data when y/c ratio = 2
13-0	R/W	0	SRC1 x end, signed data.

**Table 8-12 GE2D\_SRC1\_Y\_START\_END 0x8AB**

Bit(s)	R/W	Default	Description
31	R/W	0	SRC1 y start extra bit1, if true, one more chroma line is read for y even start chroma data when y/c ratio = 2 or x even/odd start chroma extra data when y/c ratio = 1
30	R/W	0	SRC1 y start extra bit0, if true, one more chroma line is read for y odd start chroma data when y/c ratio = 2
29-16	R/W	0	SRC1 y start, signed data
15	R/W	0	SRC1 y end extra bit1, if true, one more chroma line is read for y odd end chroma data when y/c ratio = 2 or y even/odd end chroma extra data when y/c ratio = 1
14	R/W	0	SRC1 y end extra bit0, if true, one more chroma line is read for y even end chroma data when y/c ratio = 2
13-0	R/W	0	SRC1 y end, signed data.

**Table 8-13 GE2D\_SRC1\_LUT\_ADDR 0x8AC**

Bit(s)	R/W	Default	Description
31-9	R	0	Unused.
8	R/W	1	0 = Write LUT, 1 = Read LUT.
7-0	R/W	0	lut_addr: The initial read or write address of the look-up table

**Table 8-14 GE2D\_SRC1\_LUT\_DAT 0x8AD**

Bit(s)	R/W	Default	Description
31-24	R/W	0	Current LUT entry's Y or R
23-16	R/W	0	Current LUT entry's Cb or G
15-8	R/W	0	Current LUT entry's Cr or B
7-0	R/W	0	Current LUT entry's Alpha.

Table 8-15 GE2D\_SRC1\_FMT\_CTRL 0x8AE

Bit(s)	R/W	Default	Description
31-20	R	0	Unused.
19	R/W	0	src1_chfmt_rpt_pix: if true, horizontal formatter using repeat to get the pixel, otherwise using interpolation.
18	R/W	0	src1_chfmt_en: horizontal formatter enable.
17	R/W	0	src1_cvfmt_rpt_pix: if true, vertical formatter using repeat to get the pixel, otherwise using interpolation.
16	R/W	0	src1_cvfmt_en: vertical formatter enable.
15-8	R/W	0	src1_x_chr_phase: X direction chroma phase, Bit[15:12] for x direction even start/end chroma phase when y/c ratio = 2 or start/end even/odd chroma phase when y/c ratio = 1; Bit[11:8] for x direction odd start/end chroma phase only when y/c ratio = 2.
7-0	R/W	0	src1_y_chr_phase: Y direction chroma phase. Bit[7:4] for y direction even start/end chroma phase when y/c ratio = 2 or start/end even/odd chroma phase when y/c ratio = 1; Bit[3:0] for y direction odd start/end chroma phase only when y/c ratio = 2.

Table 8-16 GE2D\_SRC2\_DEF\_COLOR 0x8AF

Bit(s)	R/W	Default	Description
31-24	R/W	0	Default Y or R.
23-16	R/W	0x80	Default Cb or G.
15-8	R/W	0x80	Default Cr or B.
7-0	R/W	0	Default Alpha.

Table 8-17 GE2D\_SRC2\_CLIPX\_START\_END 0x8B0

Bit(s)	R/W	Default	Description
31-29	R	0	Unused.
28-16	R/W	0	SRC2 clip x start.
15-13	R	0	Unused.
12-0	R/W	0x1FFF	SRC2 clip x end.

Table 8-18 GE2D\_SRC2\_CLIPY\_START\_END 0x8B1

Bit(s)	R/W	Default	Description
31-29	R	0	Unused.
28-16	R/W	0	SRC2 clip y start.
15-13	R	0	Unused.
12-0	R/W	0x1FFF	SRC2 clip y end.

**Table 8-19 GE2D\_SRC2\_X\_START\_END 0x8B2**

Bit(s)	R/W	Default	Description
31-29	R	0	Unused.
28-16	R/W	0	SRC2 x start.
15-13	R	0	Unused.
12-0	R/W	0	SRC2 x end.

**Table 8-20 GE2D\_SRC2\_Y\_START\_END 0x8B3**

Bit(s)	R/W	Default	Description
31-29	R	0	Unused.
28-16	R/W	0	SRC2 y start.
15-13	R	0	Unused.
12-0	R/W	0	SRC2 y end.

**Table 8-21 GE2D\_DST\_CLIPX\_START\_END 0x8B4**

Bit(s)	R/W	Default	Description
31-29	R	0	Unused.
28-16	R/W	0	DST clip x start.
15-13	R	0	Unused.
12-0	R/W	0x1FFF	DST clip x end.

**Table 8-22 GE2D\_DST\_CLIPY\_START\_END 0x8B5**

Bit(s)	R/W	Default	Description
31-29	R	0	Unused.
28-16	R/W	0	DST clip y start.
15-13	R	0	Unused.
12-0	R/W	0x1FFF	DST clip y end.

**Table 8-23 GE2D\_DST\_X\_START\_END 0x8B6**

Bit(s)	R/W	Default	Description
31-29	R	0	Unused.
28-16	R/W	0	DST x start.
15-13	R	0	Unused.
12-0	R/W	0	DST x end.

**Table 8-24 GE2D\_DST\_Y\_START\_END 0x8B7**

Bit(s)	R/W	Default	Description
31-29	R	0	Unused.
28-16	R/W	0	DST y start.
15-13	R	0	Unused.
12-0	R/W	0	DST y end.

**Table 8-25 GE2D\_SRC2\_DST\_CANVAS 0x8B8**

Bit(s)	R/W	Default	Description
31-24	R	0	Unused.
23-16	R/W	0	DST2 canvas address.
15-8	R/W	0	SRC2 canvas address.
7-0	R/W	0	DST1 canvas address.

**Table 8-26 GE2D\_VSC\_START\_PHASE\_STEP 0x8B9**

Bit(s)	R/W	Default	Description
31-29	R	0	Unused.
28-0	R/W	0x0100-0000	5.24 format.

**Table 8-27 GE2D\_VSC\_PHASE\_SLOPE 0x8BA**

Bit(s)	R/W	Default	Description
31-25	R	0	Unused.
24-0	R/W	0	Signed data.

**Table 8-28 GE2D\_VSC\_INI\_CTRL 0x8BB**

Bit(s)	R/W	Default	Description
31	R	0	Unused.
30-29	R/W	0	vertical repeat line0 number.
28-24	R	0	Unused.
23-0	R/W	0	vertical scaler initial phase.

**Table 8-29 GE2D\_HSC\_START\_PHASE\_STEP 0x8BC**

Bit(s)	R/W	Default	Description
31-29	R	0	Unused.
28-0	R/W	0x0100-0000	5.24 format.

**Table 8-30 GE2D\_HSC\_PHASE\_SLOPE 0x8BD**

Bit(s)	R/W	Default	Description
31-25	R	0	Unused.
24-0	R/W	0	Signed data.

**Table 8-31 GE2D\_HSC\_INI\_CTRL 0x8BE**

Bit(s)	R/W	Default	Description
31	R	0	Unused.
30-29	R/W	0	horizontal repeat line0 number.
28-24	R	0	Unused.
23-0	R/W	0	horizontal scaler initial phase.

**Table 8-32 GE2D\_HSC\_ADV\_CTRL 0x8BF**

Bit(s)	R/W	Default	Description
31-24	R/W	0	advance number in this round, if horizontal scaler is working on dividing mode.
23-0	R/W	0	horizontal scaler advance phase in this round, if horizontal scaler is working on dividing mode.

**Table 8-33 GE2D\_SC\_MISC\_CTRL 0x8C0**

Bit(s)	R/W	Default	Description
31	R	0	Unused.
30	R/W	0	vsc_nearest_en: vertical nearest mode enable, must set vt_bank_length = 4.
29	R/W	0	hsc_nearest_en: horizontal nearest mode enable, must set hz_bank_length = 4.
28	R/W	0	hsc_div_en: horizontal scaler dividing mode enable.
27-15	R/W	0	hsc_div_length: horizontal dividing length, if bit 25 is enable.
14	R/W	0	pre horizontal scaler enable.
13	R/W	0	pre vertical scale enable.
12	R/W	0	vertical scale enable.
11	R/W	0	horizontal scaler enable.
10	R	0	Unused.
9	R/W	0	HSc_rpt_ctrl: if true, treat horizontal repeat line number(GE2D_HSC_INI_CTRL bit 30:29) as repeating line, otherwise using treat horizontal repeat line number as minus line number.
8	R/W	0	VSc_rpt_ctrl: if true, treat vertical repeat line number(GE2D_VSC_INI_CTRL bit 30:29) as repeating line, otherwise using treat vertical repeat line number as minus line number.
7	R/W	0	vsc_phase0_always_en: if true, always use phase0 in vertical scaler.
6-4	R/W	2	vsc_bank_length: vertical scaler bank length.

Bit(s)	R/W	Default	Description
3	R/W	0	hsc_phase0_always_en: if true, always use phase0 in horizontal scaler.
2-0	R/W	2	hsc_bank_length: horizontal scaler bank length.

Table 8-34 GE2D\_VSC\_NRND\_POINT 0x8C1

Bit(s)	R/W	Default	Description
31-14	R	0	Unused.
13-0	R	0	vertical scaler next round integer pixel pointer, signed data.

Table 8-35 GE2D\_VSC\_NRND\_PHASE 0x8C2

Bit(s)	R/W	Default	Description
31-24	R	0	Unused.
23-0	R	0	vertical scaler next round phase.

Table 8-36 GE2D\_HSC\_NRND\_POINT 0x8C3

Bit(s)	R/W	Default	Description
31-14	R	0	Unused.
13-0	R	0	horizontal scaler next round integer pixel pointer, signed data.

Table 8-37 GE2D\_HSC\_NRND\_PHASE 0x8C4

Bit(s)	R/W	Default	Description
31-24	R	0	Unused.
23-0	R	0	horizontal scaler next round phase.

Table 8-38 GE2D\_MATRIX\_PRE\_OFFSET 0x8C5

Bit(s)	R/W	Default	Description
31-29	R	0	Unused.
28-20	R/W	0	pre_offset0.
19	R	0	Unused.
18-10	R/W	0	pre_offset1.
9	R	0	Unused.
8-0	R/W	0	pre_offset2.

**Table 8-39 GE2D\_MATRIX\_COEF00\_01 0x8C6**

Bit(s)	R/W	Default	Description
31-29	R	0	Unused.
28-16	R/W	0	coef00.
15-13	R	0	Unused.
12-0	R/W	0	coef01.

**Table 8-40 GE2D\_MATRIX\_COEF02\_10 0x8C7**

Bit(s)	R/W	Default	Description
31-29	R	0	Unused.
28-16	R/W	0	Coef02.
15-13	R	0	Unused.
12-0	R/W	0	Coef10.

**Table 8-41 GE2D\_MATRIX\_COEF11\_12 0x8C8**

Bit(s)	R/W	Default	Description
31-29	R	0	Unused.
28-16	R/W	0	Coef11.
15-13	R	0	Unused.
12-0	R/W	0	Coef12.

**Table 8-42 GE2D\_MATRIX\_COEF20\_21 0x8C9**

Bit(s)	R/W	Default	Description
31-29	R	0	Unused.
28-16	R/W	0	Coef20.
15-13	R	0	Unused.
12-0	R/W	0	Coef21.

**Table 8-43 GE2D\_MATRIX\_COEF22\_CTRL 0x8CA**

Bit(s)	R/W	Default	Description
31-29	R	0	Unused.
28-16	R/W	0	coef22.
15-8	R	0	Unused.
7	R/W	0	input y/cb/cr saturation enable.
6-1	R	0	Unused.
0	R/W	0	conversion matrix enable.

Table 8-44 GE2D\_MATRIX\_OFFSET 0x8CB

Bit(s)	R/W	Default	Description
31-29	R	0	Unused.
28-20	R/W	0	offset0.
19	R	0	Unused.
18-10	R/W	0	offset1.
9	R	0	Unused.
8-0	R/W	0	offset2.

Table 8-45 GE2D\_ALU\_OP\_CTRL 0x8CC

Bit(s)	R/W	Default	Description
31-27	R	0	Unused.
26-25	R/W	0	SRC1 color multiplier alpha selection. if 00, Cs = Csr if 01, Cs = Csr * Asr * Ag (if source is not premultiplied) if 10, Cs = Csr * Ag (if source is premultiplied).
24	R/W	0	SRC2 color multiplier alpha selection. if 0, no multiplier, Cd = Cdr, otherwise, Cd = Cdr * Ad.
23	R	0	Unused.
22-12	R/W	0x010	ALU color operation. Bit[22:20] Blending Mode Parameter. 3'b000: ADD Cs*Fs + Cd*Fd 3'b001: SUBTRACT Cs*Fs - Cd*Fd 3'b010: REVERSE SUBTRACT Cd*Fd - Cs*Fs 3'b011: MIN min(Cs*Fs, Cd*Fd) 3'b100: MAX max(Cs*Fs, Cd*Fd) 3'b101: LOGIC OP Cs op Cd .... reserved Bit[19:16] Source Color Blending Factor CFs. 4'b0000: ZERO 0 4'b0001: ONE 1 4'b0010: SRC_COLOR Cs(RGBs) 4'b0011: ONE_MINUS_SRC_COLOR 1 - Cs(RGBs) 4'b0100: DST_COLOR Cd(RGBd) 4'b0101: ONE_MINUS_DST_COLOR 1 - Cd(RGBd) 4'b0110: SRC_ALPHA As 4'b0111: ONE_MINUS_SRC_ALPHA 1 - As 4'b1000: DST_ALPHA 1 - As 4'b1001: ONE_MINUS_DST_ALPHA 1 - Ad 4'b1010: CONST_COLOR Cc(RGBc) 4'b1011: ONE_MINUS_CONST_COLOR 1 - Cc(RGBc) 4'b1100: CONST_ALPHA Ac 4'b1101: ONE_MINUS_CONST_ALPHA 1 - Ac 4'b1110: SRC_ALPHA_SATURATE min(As, 1-Ad) .... reserved Bit[15:12] dest Color Blending Factor CFd, when bit[22:20] != LOGIC OP. 4'b0000: ZERO 0 4'b0001: ONE 1 4'b0010: SRC_COLOR Cs(RGBs) 4'b0011: ONE_MINUS_SRC_COLOR 1 - Cs(RGBs) 4'b0100: DST_COLOR Cd(RGBd) 4'b0101: ONE_MINUS_DST_COLOR 1 - Cd(RGBd) 4'b0110: SRC_ALPHA As 4'b0111: ONE_MINUS_SRC_ALPHA 1 - As 4'b1000: DST_ALPHA 1 - As 4'b1001: ONE_MINUS_DST_ALPHA 1 - Ad 4'b1010: CONST_COLOR Cc(RGBc) 4'b1011: ONE_MINUS_CONST_COLOR 1 - Cc(RGBc) 4'b1100: CONST_ALPHA Ac 4'b1101: ONE_MINUS_CONST_ALPHA 1 - Ac 4'b1110: SRC_ALPHA_SATURATE min(As, 1-Ad) .... reserved Bit[15:12] logic operations, when bit[22:20] == LOGIC OP. 4'b0000: CLEAR 0 4'b0001: COPY s 4'b0010: NOOP d 4'b0011: SET 1 4'b0100: COPY_INVERT ~s 4'b0101: INVERT ~d 4'b0110: AND_REVERSE s & ~d 4'b0111: OR_REVERSE s   ~d 4'b1000: AND s & d 4'b1001: OR s   d 4'b1010: NAND ~(s & d) 4'b1011: NOR ~(s   d) 4'b1100: XOR s ^ d 4'b1101: EQUIV ~(s ^ d) 4'b1110: AND_INVERTED ~s & d 4'b1111: OR_INVERTED ~s   d



Bit(s)	R/W	Default	Description
11	R	0	Unused.
10-0	R/W	0x010	ALU alpha operation. Bit[10:8] Blending Equation Math Operation. 3'b000: ADD As*Fs + Ad*Fd 3'b001: SUBTRACT As*Fs - Ad*Fd 3'b010: REVERSE SUBTRACT Ad*Fd - As*Fs 3'b011: MIN min(As*Fs, Ad*Fd) 3'b100: MAX max(As*Fs, Ad*Fd) 3'b101: LOGIC OP As op Ad .... reserved Bit[7:4] Source alpha Blending Factor AFs. 4'b0000 0 4'b0001 1 4'b0010 As 4'b0011 1 - As 4'b0100 Ad 4'b0101 1 - Ad 4'b0110 Ac 4'b0111 1 - Ac .... reserved Bit[3:0] Destination alpha Blending Factor AFd, when bit[10:8] != LOGIC OP. 4'b0000 0 4'b0001 1 4'b0010 As 4'b0011 1 - As 4'b0100 Ad 4'b0101 1 - Ad 4'b0110 Ac 4'b0111 1 - Ac .... reserved Bit[3:0] logic operations, when bit[10:8] == LOGIC OP. 4'b0000: CLEAR 0 4'b0001: COPY s 4'b0010: NOOP d 4'b0011: SET 1 4'b0100: COPY_INVERT ~s 4'b0101: INVERT ~d 4'b0110: AND_REVERSE s & ~d 4'b0111: OR_REVERSE s   ~d 4'b1000: AND s & d 4'b1001: OR s   d 4'b1010: NAND ~(s & d) 4'b1011: NOR ~(s   d) 4'b1100: XOR s ^ d 4'b1101: EQUIV ~(s ^ d) 4'b1110: AND_INVERTED ~s & d 4'b1111: OR_IN- VERTED ~s   d

Table 8-46 GE2D\_ALU\_CONST\_COLOR 0x8CD

Bit(s)	R/W	Default	Description
31-0	R/W	0x0080-8000	RGBA or YCbCrA.

Table 8-47 GE2D\_SRC1\_KEY 0x8CE

Bit(s)	R/W	Default	Description
31-0	R/W	0	SRC1 Key.

Table 8-48 GE2D\_SRC1\_KEY\_MASK 0x8CF

Bit(s)	R/W	Default	Description
31-0	R/W	0	SRC1 Key Mask.

Table 8-49 GE2D\_SRC2\_KEY 0x8D0

Bit(s)	R/W	Default	Description
31-0	R/W	0	SRC2 Key.

Table 8-50 GE2D\_SRC2\_KEY\_MASK 0x8D1

Bit(s)	R/W	Default	Description
31-0	R/W	0	Destination Bit Mask.

Table 8-51 GE2D\_DP\_ONOFF\_CTRL 0x8D3

Bit(s)	R/W	Default	Description
31	R/W	0	DP onoff mode. 0: on_counter means how many pixels will output before ge2d turns off; 1: on_counter means how many clocks will ge2d turn on before ge2d turns off.
30-16	R/W	0	DP on counter.
15	R/W	0	0: vd_format doesnt have onoff mode, 1: vd format has onoff mode.
14-0	R/W	0	DP off counter.

Because there are many coefficients used in the vertical filter and horizontal filters, indirect access the coefficients of vertical filter and horizontal filter is used. For vertical filter, there are 33x4 coefficients. For horizontal filter, there are 33x4 coefficients

Table 8-52 GE2D\_SCALE\_COEF\_IDX 0x8D4

Bit(s)	R/W	Default	Description
31-16	R	0	Unused.
15	R/W	0	index increment, if bit9 == 1 then (0: index increase 1, 1: index increase 2) else (index increase 2).
14	R/W	0	1: read coef through cbus enable, just for debug purpose in case when we wanna check the coef in ram in correct or not.
13-10	R	0	Unused.
9	R/W	0	if true, use 9bit resolution coef, other use 8bit resolution coef.
8	R/W	0	type of index, 0: vertical coef; 1: horizontal coef.
7	R	0	Unused.
6-0	R/W	0	coef index.

Table 8-53 GE2D\_SCALE\_COEF 0x8D5

Bit(s)	R/W	Default	Description
31-0	R/W	0	coefficients for vertical filter and horizontal filter.

Table 8-54 GE2D\_SRC\_OUTSIDE\_ALPHA 0x8D6

Bit(s)	R/W	Default	Description
31-25	R	0	Unused.
24	R/W	0	src2 alpha fill mode: together with GE2D_GEN_CTRL0[14](fill_mode), define what alpha values are used. 0: repeat inner alpha, 1: fill src2 outside alpha.  for the area outside the clipping window. As below: fill_mode=0, alpha_fill_mode=0 : use inner alpha, (or default_alpha if src data have no alpha values); fill_mode=0, alpha_fill_mode=1 : use outside_alpha; fill_mode=1, alpha_fill_mode=0 : use default_alpha; fill_mode=1, alpha_fill_mode=1 : use outside_alpha.
23-16	R/W	16	src2 outside alpha.
15-9	R	0	Unused.

Bit(s)	R/W	Default	Description
8	R/W	1	src1 alpha fill mode, refer to src2 alpha fill mode above.
7-0	R/W	0	src1 outside alpha.

Table 8-55 GE2D\_ANTIFLICK\_CTRL0 0x8D8

Bit(s)	R/W	Default	Description
31	R/W	0	antiflick enable
24	R/W	0	1: alpha value for the first line use repeated alpha, 0: use bit 23:16 as the first line alpha
23-16	R/W	0	register value for the first line alpha when bit 24 is 1.
8	R/W	0	1: alpha value for the last line use repeated alpha, 0: use bit 7:0 as the last line alpha
7-0	R/W	0	register value for the last line alpha when bit 8 is 1.

Table 8-56 GE2D\_ANTIFLICK\_CTRL1 0x8D9

Bit(s)	R/W	Default	Description
25	R/W	0	rgb_sel, 1: antiflick RGBA, 0: antiflick YCbCrA
24	R/W	0	cbr_en, 1: also filter cbr in case of antiflicking YCbCrA, 0: no filter on cbr in case of antiflicking YCbCrA
23-16	R/W	0	R mult coef for converting RGB to Y
15- 8	R/W	0	G mult coef for converting RGB to Y
7-0	R/W	0	B mult coef for converting RGB to Y

$$Y = (R * y_r + G * y_g + B * y_b) / 256$$

Table 8-57 GE2D\_ANTIFLICK\_COLOR\_FILTER0 0x8DA

Bit(s)	R/W	Default	Description
31-24	R/W	0	Y threshold1, when $0 < Y \leq th1$ , use filter0.
23-16	R/W	0	color antiflick filter0 n3
15- 8	R/W	0	color antiflick filter0 n2
7-0	R/W	0	color antiflick filter0 n1

$$Y = (line\_up * n1 + line\_center * n2 + line\_dn * n3) / 128$$

Table 8-58 GE2D\_ANTIFLICK\_COLOR\_FILTER1 0x8DB

Bit(s)	R/W	Default	Description
31-24	R/W	0	Y threshold2, when $th1 < Y \leq th2$ , use filter1.
23-16	R/W	0	color antiflick filter1 n3
15- 8	R/W	0	color antiflick filter1 n2
7-0	R/W	0	color antiflick filter1 n1

**Table 8-59 GE2D\_ANTIFLICK\_COLOR\_FILTER2 0x8DC**

Bit(s)	R/W	Default	Description
31-24	R/W	0	Y threshold3, when $th2 < Y \leq th3$ , use filter2 ; $Y > th3$ , use filter3.
23-16	R/W	0	color antiflick filter2 n3
15- 8	R/W	0	color antiflick filter2 n2
7-0	R/W	0	color antiflick filter2 n1

**Table 8-60 GE2D\_ANTIFLICK\_COLOR\_FILTER3 0x8DD**

Bit(s)	R/W	Default	Description
23-16	R/W	0	color antiflick filter3 n3
15- 8	R/W	0	color antiflick filter3 n2
7-0	R/W	0	color antiflick filter3 n1

**Table 8-61 GE2D\_ANTIFLICK\_ALPHA\_FILTER0 0x8DE**

Bit(s)	R/W	Default	Description
31-24	R/W	0	Alpha threshold1, when $0 < Alpha \leq th1$ , use filter0.
23-16	R/W	0	Alpha antiflick filter0 n3
15- 8	R/W	0	Alpha antiflick filter0 n2
7-0	R/W	0	Alpha antiflick filter0 n1

$$\text{Alpha} = (\text{line\_up} * n1 + \text{line\_center} * n2 + \text{line\_dn} * n3) / 128$$

**Table 8-62 GE2D\_ANTIFLICK\_ALPHA\_FILTER1 0x8DF**

Bit(s)	R/W	Default	Description
31-24	R/W	0	Alpha threshold2, when $th1 < Alpha \leq th2$ , use filter1.
23-16	R/W	0	Alpha antiflick filter1 n3
15- 8	R/W	0	Alpha antiflick filter1 n2
7-0	R/W	0	Alpha antiflick filter1 n1

**Table 8-63 GE2D\_ANTIFLICK\_ALPHA\_FILTER2 0x8E0**

Bit(s)	R/W	Default	Description
31-24	R/W	0	Alpha threshold3, when $th2 < Alpha \leq th3$ , use filter2; $Alpha > th3$ , use filter3.
23-16	R/W	0	Alpha antiflick filter2 n3
15- 8	R/W	0	Alpha antiflick filter2 n2
7-0	R/W	0	Alpha antiflick filter2 n1

**Table 8-64 GE2D\_ANTIFLICK\_ALPHA\_FILT3 0x8E1**

Bit(s)	R/W	Default	Description
23-16	R/W	0	Alpha antiflick filter3 n3
15- 8	R/W	0	Alpha antiflick filter3 n2
7-0	R/W	0	Alpha antiflick filter3 n1

**Table 8-65 GE2D\_SRC1\_RANGE\_MAP\_Y\_CTRL 0x8E3**

Bit(s)	R/W	Default	Description
30-22	R/W	0	din_offset (signed data)
21-14	R/W	0	map_coef (unsigned data)
13- 10	R/W	0	map_sr (unsigned data)
9-1	R/W	0	dout_offset (signed data)
0	R/W	0	enable

$dout = \text{clipto\_0\_255}(((din + din\_offset) * map\_coef + ((1 \ll (map\_sr - 1))) \gg map\_sr + dout\_offset)$

**Table 8-66 GE2D\_SRC1\_RANGE\_MAP\_CB\_CTRL 0x8E4**

Bit(s)	R/W	Default	Description
30-22	R/W	0	din_offset (signed data)
21-14	R/W	0	map_coef (unsigned data)
13- 10	R/W	0	map_sr (unsigned data)
9-1	R/W	0	dout_offset (signed data)
0	R/W	0	enable

$dout = \text{clipto\_0\_255}(((din + din\_offset) * map\_coef + ((1 \ll (map\_sr - 1))) \gg map\_sr + dout\_offset)$

**Table 8-67 GE2D\_SRC1\_RANGE\_MAP\_CR\_CTRL 0x8E5**

Bit(s)	R/W	Default	Description
30-22	R/W	0	din_offset (signed data)
21-14	R/W	0	map_coef (unsigned data)
13- 10	R/W	0	map_sr (unsigned data)
9-1	R/W	0	dout_offset (signed data)
0	R/W	0	enable

$dout = \text{clipto\_0\_255}(((din + din\_offset) * map\_coef + ((1 \ll (map\_sr - 1))) \gg map\_sr + dout\_offset)$

Table 8-68 GE2D\_ARB\_BURST\_NUM 0x8E6

Bit(s)	R/W	Default	Description
21-16	R/W	0x3f	Src1 prearbitor burst number
13-8	R/W	0x3f	Src2 prearbitor burst number
5-0	R/W	0x3f	dst prearbitor burst number

Table 8-69 GE2D\_TID\_TOKEN 0x8E7

Bit(s)	R/W	Default	Description
21-16	R/W	0x3f	Src1 ID. High 4bit are thread ID, low 2bits are the token
13-8	R/W	0x3f	Src2 ID. High 4bit are thread ID, low 2bits are the token
5-0	R/W	0x3f	dst ID. High 4bit are thread ID, low 2bits are the token

Table 8-70 GE2D\_GEN\_CTRL3 0x8E8

Bit(s)	R/W	Default	Description
31-28	R/W	0	dst2_bytemask_val: 1-bit mask for each byte (8-bit). Applicable only if both dst_bitmask_en=1 and dst_bytemask_only=1.
27-26	R/W	0	dst2_pic_struct: Define how destination 2 write the picture to DDR memory. 0: Write all lines (whole frame); 1: Reserved; 2: Write even lines only (top); 3: Write odd lines only (bottom).
25-24	R/W	0	dst2_8b_mode_sel: Destination 8-bit mode component selection. 0: Select Y or R; 1: Select Cb or G; 2: Select Cr or B; 3: Select Alpha.
23	R	0	Unused
22-19	R/W	0	dst2_color_map: Applicable to 16-bit, 24-bit and 32-bit pixel, defines the bit-field allocation of the pixel data. For whether to truncate or round full 8-bit to output, refer to ge2d_gen_ctrl3.dst2_color_round_mode.  For 16-bit mode (dst2_format=1): 0 = Unused; 1 = 6:5:5 format. Bit[15:10] is Y[7:2] or R[7:2], bit[9:5] is Cb[7:3] or G[7:3], bit[4:0] is Cr[7:3] or B[7:3]; 2 = 8:4:4 format. Bit[15:8] is Y or R, bit[7:4] is Cb[7:4] or G[7:4], bit[3:0] is Cr[7:4] or B[7:4]; 3 = 6:4:4:2 format. Bit[15:10] is Y[7:2] or R[7:2], bit[9:6] is Cb[7:4] or G[7:4], bit [5:2] is Cr[7:4] or B[7:4], bit[1:0] is Alpha[7:6]; 4 = 4:4:4:4 format. Bit[15:12] is Y[7:4] or R[7:4], bit[11:8] is Cb[7:4] or G[7:4], bit [7:4] is Cr[7:4] or B[7:4], bit[3:0] is Alpha[7:4]; 5 = 5:6:5 format. Bit[15:11] is Y[7:3] or R[7:3], bit[10:5] is Cb[7:2] or G[7:2], bit [4:0] is Cr[7:3] or B[7:3]; 6 = 4:4:4:4 format. Bit[15:12] is Alpha[7:4], bit[11:8] is Y[7:4] or R[7:4], bit[7:4] is Cb[7:4] or G[7:4], bit[3:0] is Cr[7:4] or B[7:4]; 7 = 1:5:5:5 format. Bit[15] is Alpha[7], bit[14:10] is Y[7:3] or R[7:3], bit[9:5] is Cb [7:3] or G[7:3], bit[4:0] is Cr[7:3] or B[7:3]; 8 = 4:6:4:2 format. Bit[15:12] is Y[7:4] or R[7:4], bit[11:6] is Cb[7:2] or G[7:2], bit [5:2] is Cr[7:4] or B[7:4], bit[1:0] is Alpha[1:0]; 9 = CbCr format. Bit[15:8] is Cb, bit[7:0] is Cr; 10 = CrCb format. Bit[15:8] is Cr, bit[7:0] is Cb.  For 24-bit mode (dst2_format=2):

Bit(s)	R/W	Default	Description
			<p>0 = RGB 8:8:8 mode. Bit[23:16] is Y or R, bit[15:8] is Cb or G, bit[7:0] is Cr or B;            1 = RGBA 5:6:5:8 mode. Bit[23:19] is Y[7:3] or R[7:3], bit[18:13] is Cb[7:2] or G[7:2], bit[12:8] is Cr[7:3] or B[7:3], bit[7:0] is Alpha;            2 = ARGB 8:5:6:5 mode. Bit[23:16] is Alpha, bit[15:11] is Y[7:3] or R[7:3], bit[10:5] is Cb[7:2] or G[7:2], bit[4:0] is Cr[7:3] or B[7:3];            3 = RGBA 6:6:6:6 mode. Bit[23:18] is Y[7:2] or R[7:2], bit[17:12] is Cb[7:2] or G[7:2], bit[11:6] is Cr[7:2] or B[7:2], bit[5:0] is Alpha[7:2];            4 = ARGB 6:6:6:6 mode. Bit[23:18] is Alpha[7:2], bit[17:12] is Y[7:2] or R[7:2], bit[11:6] is Cb[7:2] or G[7:2], bit[5:0] is Cr[7:2] or B[7:2];            5 = BGR 8:8:8 mode. Bit[23:16] is Cr or B, bit[15:8] is Cb or G, bit[7:0] is Y or R.</p> <p>For 32-bit mode (dst2_format=3):            0 = RGBA 8:8:8:8 format. Bit[31:24] is Y or R, bit[23:16] is Cb or G; bit[15:8] is Cr or B; bit[7:0] is Alpha;            1 = ARGB 8:8:8:8 format. Bit[31:24] is Alpha, bit[23:16] is Y or R; bit[15:8] is Cb or G; bit[7:0] is Cr or B;            2 = ABGR 8:8:8:8 format. Bit[31:24] is Alpha, bit[23:16] is Cr or B; bit[15:8] is Cb or G; bit[7:0] is Y or R;            3 = BGRA 8:8:8:8 format. Bit[31:24] is Cr or B, bit[23:16] is Cb or G; bit[15:8] is Y or R; bit[7:0] is Alpha.</p>
18	R	0	Unused
17-16	R/W	0	<p>dst2_format: define DST2 output pixel byte-width.            0: Output pixel is 1-byte (8-bit) color component;            1: Output pixel is 2-byte (16-bit), refer to GE2D_GEN_CTRL3.dst2_COLOR_map for further pixel color mapping;            2: Output pixel is 3-byte (24-bit), refer to GE2D_GEN_CTRL3.dst2_COLOR_MAP for further pixel color mapping;            3: Output pixel is 4-byte (32-bit), refer to GE2D_GEN_CTRL3.dst2_COLOR_MAP for further pixel color mapping.</p>
15	R	0	Unused
14	R/W	0	<p>dst2_COLOR_round_MODE.            1 = Truncate the full bit color components to required output bit width;            0 = Round (+ 0.5) the full bit color components to required output bit width.</p>
13-12	R/W	0	<p>dst2_x_discard_mode: Define how DST2 discard X direction data before writing to DDR.            Note: x is post reverse/rotation.            0: No discard;            1: Reserved;            2: discard even x;            3: discard odd x.</p>
11-10	R/W	0	<p>dst2_y_discard_mode: Define how DST2 discard Y direction data before writing to DDR.            Note: y is post reverse/rotation.            0: No discard;            1: Reserved;            2: discard even y;            3: discard odd y.</p>
9	R	0	Unused
8	R/W	0	<p>dst2_enable:            0: Disable destination 2;            1: Enable destination 2.</p>
7-6	R	0	Unused
5-4	R/W	0	<p>dst1_x_discard_mode: Define how DST1 discard X direction data before writing to DDR.            Note: x is post reverse/rotation.            0: No discard;            1: Reserved;            2: discard even x;            3: discard odd x.</p>

Bit(s)	R/W	Default	Description
3-2	R/W	0	dst1_y_discard_mode: Define how DST1 discard Y direction data before writing to DDR. Note: y is post reverse/rotation. 0: No discard; 1: Reserved; 2: discard even y; 3: discard odd y.
1	R	0	Unused
0	R/W	1	dst1_enable: 0: Disable destination 1; 1: Enable destination 1.

Table 8-71 GE2D\_STATUS2 0x8E9

Bit(s)	R/W	Default	Description
13-12	R	0	ge2d_dst1.ctrl_status
11	R	0	ge2d_dst1.map_srdy
10	R	0	ge2d_dst1.map_d1_srdy
9	R	0	ge2d_dst1.s_v
8	R	0	ge2d_dst1.ofifo_dout_srdy
7-1	R	0	ge2d_dst1.ofifo_cnt
0	R	0	ge2d_dst1.dst_busy

Table 8-72 GE2D\_GEN\_CTRL4 0x8EA

Bit(s)	R/W	Default	Description
0	R/W	0	dis_dp_hang_bugfix.

Table 8-73 GE2D\_DST1\_BADDR\_CTRL 0x8f1

Bit(s)	R/W	Default	Description
31-0	R/W	0	DST1 base address in 64bits.

Table 8-74 GE2D\_DST1\_STRIDE\_CTRL 0x8f2

Bit(s)	R/W	Default	Description
19-0	R/W	0	DST1 stride size in 64bits.

Table 8-75 GE2D\_SRC1\_BADDR\_CTRL 0x8f3

Bit(s)	R/W	Default	Description
31-0	R/W	0	SRC1 base address in 64bits.



**Table 8-76 GE2D\_SRC1\_STRIDE\_CTRL 0x8f4**

Bit(s)	R/W	Default	Description
19-0	R/W	0	SRC1 stride size in 64bits.

**Table 8-77 GE2D\_SRC2\_BADDR\_CTRL 0x8f5**

Bit(s)	R/W	Default	Description
31-0	R/W	0	SRC2 base address in 64bits.

**Table 8-78 GE2D\_SRC2\_STRIDE\_CTRL 0x8f6**

Bit(s)	R/W	Default	Description
19-0	R/W	0	SRC2 stride size in 64bits.

Confidential for Hardkernel!!

## 9 Video Path

This section describe the SoC's video path from the following aspects:

- Video Input
- Video Output
  - RDMA
  - VPP(VIU/VPP)
  - CVBS

The data path of the video path module is shown in the figure below:

**Figure 9-1 Data Path of Video Path**

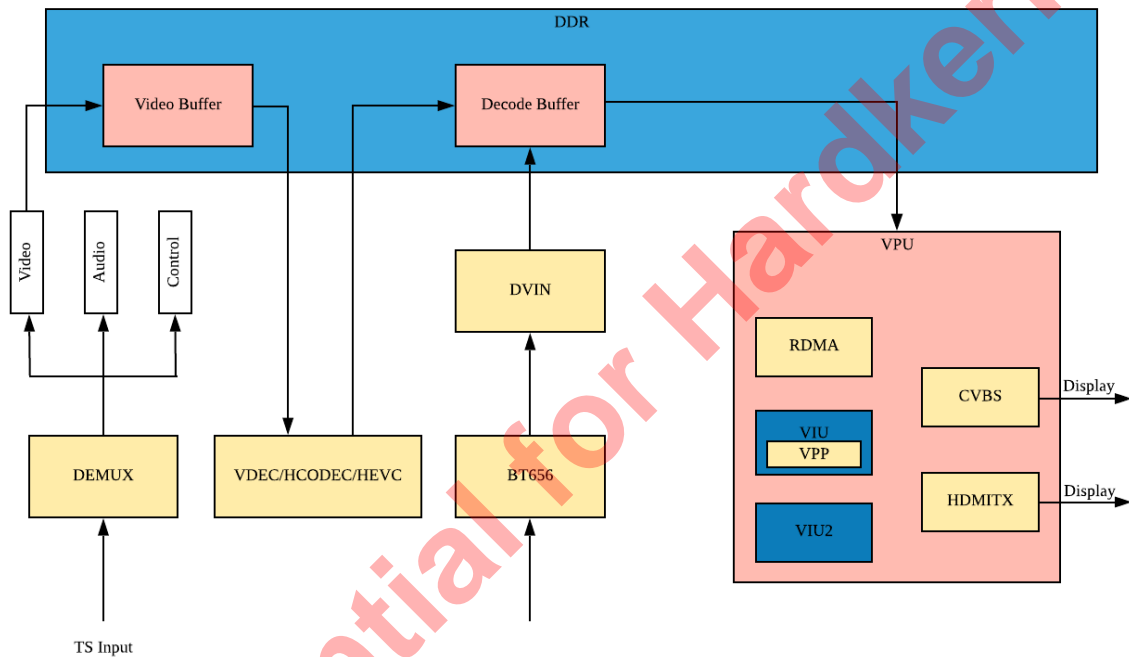

### 9.1 Video Input

#### 9.1.1 Overview

This part describes the video input module of the SoC which uses DEMUX to handle input video signals, and store the demuxed signal in DDR, which can be read directly.

Demux submodule of the SoC is designed for connecting to external digital TV tuner/demodular and de-mux the input signal. It decomposes the input signal from TS/DDR into video signal, audio signal, and clock signal, the video signal will be first written in to DDR, then decoded by the video decoder (VDEC). Below shows the diagram of Demux submodule.

Figure 9-2 Demux Submodule

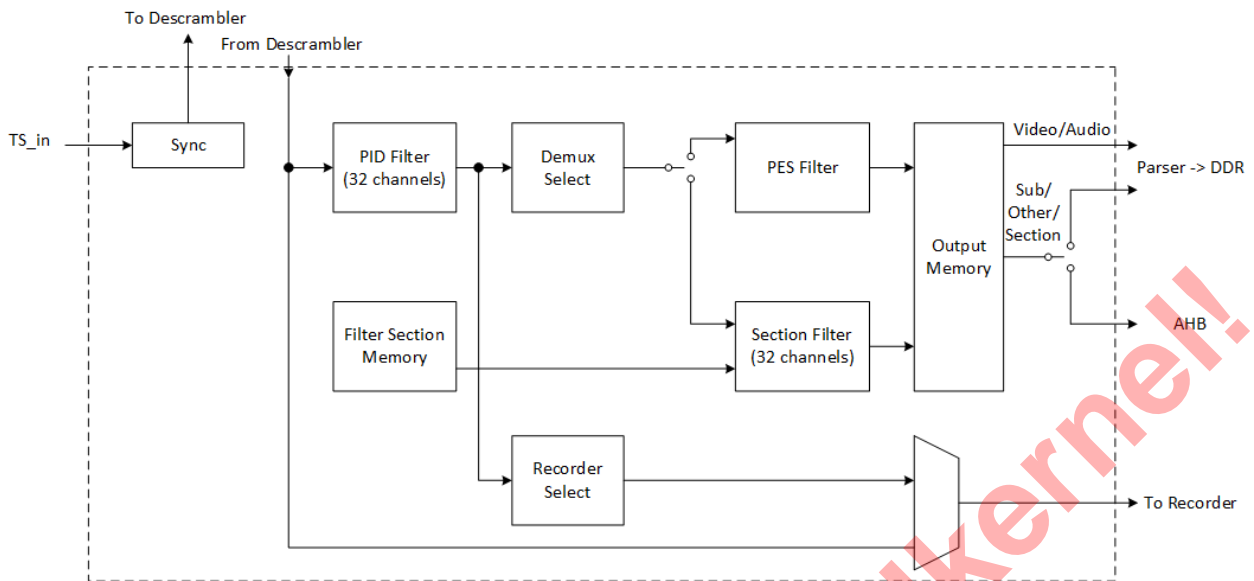

The SoC intergrades 3 demux controllers, with the following features:

- Supports PID filter up to 32 channels
- Supports session filter up to 32 channels
- Supports up to 96 channels filter when use 3 demux as one group
- Supports AES/DES/DVB-CSA 1.0 crypto
- Supports inputs from both external TS inputs (serial or parallel, depending on pinmux) and DDR memory (file playback path)
- Supports input loopback to TS-out pins
- Supports separate selection for playback and recorder

### 9.1.2 Register Description

#### 9.1.2.1 Demux Register

Below are registers for Demux.

#### Demux Common Registers

Final address = 0xffd06000 + offset \* 4

Table 9-1 TS\_HIU1\_CONFIG 0x4e

Bit(s)	R/W	Default	Description
31:24	RW	0	file_m2ts_skip_bytes_hiu1
21	RW	0	ts_hiu_enable_hiu1
20:16	RW	0	fec_clk_div_hiu1
15:8	RW	0	TS_package_length_sub_1_hiu1
7:0	RW	8'h47	fec_sync_byte_hiu1

**Table 9-2 TS\_TOP\_CONFIG1 0x4f**

Bit(s)	R/W	Default	Description
31:6	RW	0	reserved
5:4	RW	2	fec_sel_demux_2
3:2	RW	1	fec_sel_demux_1
1:0	RW	0	fec_sel_demux_0

**Table 9-3 STB\_RECORDER2\_CNTL 0xee**

Bit(s)	R/W	Default	Description
31:2	RW	0	reserved
1:0	RW	1	stb_recorder2_sel

**Table 9-4 STB\_S2P2\_CONFIG 0xef**

Bit(s)	R/W	Default	Description
31:12	RW	0	reserved
11	RW	0	s2p2_disable
10:7	RW	7	s2p2_clk_div
6	RW	0	invert fec_error for S2P2
5	RW	0	invert fec_data for S2P2
4	RW	0	invert fec_sync for S2P2
3	RW	0	invert fec_valid for S2P2
2	RW	0	invert fec_clk for S2P2
1:0	RW	0	fec_s_sel for S2P2 00 - select TS0, 01 – select TS1, 10 – select TS2, 11 - TS3

**Table 9-5 STB\_TOP\_CONFIG 0xf0**

Bit(s)	R/W	Default	Description
30:28	RW	0	ciplus_o_sel
27:26	RW	0	ciplus_i_sel
25	RW	0	use FAIL from TS2
24	RW	0	use FAIL from TS1
23	RW	0	use FAIL from TS0
22	RW	0	invert fec_error for S2P1
21	RW	0	invert fec_data for S2P1
20	RW	0	invert fec_sync for S2P1
19	RW	0	invert fec_valid for S2P1
18	RW	0	invert fec_clk for S2P1

Bit(s)	R/W	Default	Description
17:16	RW	0	fec_s_sel for S2P1 00 - select TS0, 01 – select TS1, 10 – select TS2, 11 - TS3
15	RW	0	enable_des_pl_clk
14:13	RW	0	reserved
13	RW	0	use FAIL for TS3
12:10	RW	0	ts_out_select, 0-TS0, 1-TS1, 2-TS2, 3-TS3, 4-S2P2, 5-S2P1, 6-S2P0, 7-File
9:8	RW	0	des_i_sel 00 – select_fec_0, 01 – select_fec_1, 10 – select_fec_2, 11 - TS3
7	RW	0	enable_des_pl
6	RW	0	invert fec_error for S2P0
5	RW	0	invert fec_data for S2P0
4	RW	0	invert fec_sync for S2P0
3	RW	0	invert fec_valid for S2P0
2	RW	0	invert fec_clk for S2P0

Table 9-6 TS\_TOP\_CONFIG 0xf1

Bit(s)	R/W	Default	Description
31:28	RW	7	s2p1_clk_div
27:24	RW	7	s2p0_clk_div
23	RW	0	s2p1_disable
22	RW	0	s2p0_disable
21	RW	0	Reserved
20	RW	0	TS_OUT_error_INVERT
19	RW	0	TS_OUT_data_INVERT
18	RW	0	TS_OUT_sync_INVERT
17	RW	0	TS_OUT_valid_INVERT
16	RW	0	TS_OUT_clk_INVERT
15:8	RW	187	TS_package_length_sub_1 (default : 187)
7:0	RW	0x47	fec_sync_byte (default : 0x47)

Table 9-7 TS\_FILE\_CONFIG 0xf2

Bit(s)	R/W	Default	Description
25:24	RW	3	transport_scrambling_control_odd_2 // should be 3
23:16	RW	0	file_m2ts_skip_bytes
15:8	RW	0	des_out_dly
7:6	RW	3	transport_scrambling_control_odd // should be 3

Bit(s)	R/W	Default	Description
5	RW	0	ts_hiu_enable
4:0	RW	4	fec_clk_div

**Table 9-8 TS\_PL\_PID\_INDEX 0xf3**

Bit(s)	R/W	Default	Description
19:14	R	0	des_2 ts pl state – Read Only
13:8	R	0	des ts pl state – Read Only
3:0	RW	0	PID index to 8 PID to get key-set

**Table 9-9 TS\_PL\_PID\_DATA 0xf4**

Bit(s)	R/W	Default	Description
29	RW	0	PID #INDEX +1 match disble
28:16	RW	0	PID #INDEX+1
13	RW	0	PID #INDEX match disble
12:0	RW	0	PID #INDEX

**Table 9-10 COMM\_DESC\_KEY0 0xf5**

Bit(s)	R/W	Default	Description
31:0	RW	0	Common descrambler key (key Bits[63:32])

**Table 9-11 COMM\_DESC\_KEY1 0xf6**

Bit(s)	R/W	Default	Description
31:0	RW	0	Common descrambler key (key Bits[31:0])

**Table 9-12 COMM\_DESC\_KEY\_RW 0xf7**

Bit(s)	R/W	Default	Description
7	RW	0	Key endian;
6	RW	0	Write key ladder cw [127:64] to key;
5	RW	0	Write key ladder cw [63:0] to key;
4	RW	0	0: write to descramble 1; 1: write to descramble 2;
3:0	RW	0	The address of key

**Table 9-13 CIPLUS\_KEY0 0xf8**

Bit(s)	R/W	Default	Description
31:0	RW	0	CI+ Register defines Bits[31:0] of the key

**Table 9-14 CIPLUS\_KEY1 0xf9**

Bit(s)	R/W	Default	Description
31:0	RW	0	CI+ Register defines Bits[63:32] of the key

**Table 9-15 CIPLUS\_KEY2 0xfa**

Bit(s)	R/W	Default	Description
31:0	RW	0	CI+ Register defines Bits[95:64] of the key

**Table 9-16 CIPLUS\_KEY3 0xfb**

Bit(s)	R/W	Default	Description
31:0	RW	0	CI+ Register defines Bits[127:96] of the key

**Table 9-17 CIPLUS\_KEY\_WR 0xfc**

Bit(s)	R/W	Default	Description
5	RW	0	write AES IV B value
4	RW	0	write AES IV A value
3	RW	0	write AES B key
2	RW	0	write AES A key
1	RW	0	write DES B key
0	RW	0	write DES A key

**Table 9-18 CIPLUS\_CONFIG 0xfd**

Bit(s)	R/W	Default	Description
15:8	RW	0	TS out delay. This controls the rate at which the Cplus module drives TS out
3	RW	0	General enable for the cplus module
2	RW	0	AES CBC disable (default should be 0 to enable AES CBC)
1	RW	0	AES Enable
0	RW	0	DES Eanble

**Table 9-19 CIPLUS\_ENDIAN 0xfe**

Bit(s)	R/W	Default	Description
31:28	RW	0	AES IV endian
27:24	RW	0	AES message out endian
23:20	RW	0	AES message in endian
19:16	RW	0	AES key endian

Bit(s)	R/W	Default	Description
15:11	RW	0	unused
10:8	RW	0	DES message out endian
6:4	RW	0	DES message in endian
2:0	RW	0	DES key endian

Table 9-20 COMM\_DESC\_2\_CTL 0xff

Bit(s)	R/W	Default	Description
15:8	RW	0	des_out_dly_2
7	RW	0	reserved
6	RW	0	enable_des_pl_clk_2
5	RW	0	enable_des_pl_2
4:2	RW	0	use_des_2 Bit[2] – demux0, Bit[3] – demux1, Bit[4] – demux2
1:0	RW	0	des_i_sel_2 00 – select_fec_0, 01 – select_fec_1, 10 – select_fec_2, 11 - reserved
23	R/W	0	gp1_dpll_fb_pre_div
22	R/W	0	gp1_dpll_filter_mode
21	R/W	0	gp1_dpll_fix_en
20	R/W	0	gp1_dpll_freq_shift_en
19	R/W	0	gp1_dpll_load
18	R/W	0	gp1_dpll_load_en
17	R/W	0	gp1_dpll_lock_f
16	R/W	0	gp1_dpll_pulse_width_en
15	R/W	0	gp1_dpll_sdmnc_en
14	R/W	0	gp1_dpll_sdmnc_mode
13	R/W	0	gp1_dpll_sdmnc_range
12	R/W	0	gp1_dpll_tdc_en
11	R/W	0	gp1_dpll_tdc_mode_sel
10	R/W	0	gp1_dpll_wait_en

### Demux Core Registers

demux core 0 Final address = 0xc1105800 + offset \* 4

demux core 1 Final address = 0xc1105940 + offset \* 4

demux core 2 Final address = 0xc1105a80 + offset \* 4



**Table 9-21 STB\_VERSION\_O 0x00**

Bit(s)	R/W	Default	Description
31:0	R	0x30003	The version of stb

**Table 9-22 STB\_TEST\_REG\_O 0x01**

Bit(s)	R/W	Default	Description
31:0	RW	0xfe015-aa5	Test register.

**Table 9-23 FEC\_INPUT\_CONTROL\_O 0x02**

Bit(s)	R/W	Default	Description
16	RW	0	fec_select[3]
15	RW	0	fec_core_select 1 - select descramble output
14:12	RW	0	fec_select[2:0] 0-TS0, 1-TS1, 2-TS2, 3-TS3,4-S2P2, 5-S2P1, 6-S2P0, 7-File, 8-File1
11	RW	0	FEC_CLK
10	RW	0	SOP
9	RW	0	D_VALID
8	RW	0	D_FAIL
7:0	RW	0	D_DATA 7:0

**Table 9-24 FEC\_INPUT\_DATA\_O 0x03**

Bit(s)	R/W	Default	Description
11	R	0	FEC_CLK
20	R	0	SOP
9	R	0	VALID
8	R	0	FAIL
7:0	R	0	FEC DATAIN

**Table 9-25 DEMUX\_CONTROL\_O 0x04**

Bit(s)	R/W	Default	Description
31	RW	0	enable_free_clk_fec_data_valid
30	RW	0	enable_free_clk_stb_reg
29	RW	0	always_use_pes_package_length
28	RW	0	disable_pre_incomplete_section_fix
27	RW	0	pointer_field_multi_pre_en

Bit(s)	R/W	Default	Description
26	RW	0	ignore_pre_incomplete_section
25	RW	0	video2_enable
24:22	RW	0	video2_type
21	RW	0	do_not_trust_pes_package_length
20 (bit4)	RW	0	Bypass use recoder path
19 (bit3)	RW	0	clear_PID_continuity_counter_valid
18 (bit2)	RW	0	Disable Splicing
17 (bit1)	RW	0	Insert PES_STRONG_SYNC in Audio PES
16 (bit0)	RW	0	Insert PES_STRONG_SYNC in Video PES
15	RW	0	do not trust section length
14	RW	0	om cmd push even zero
13	RW	0	set_buff_ready_even_not_busy
12	RW	0	SUB, OTHER PES interrupt at beginning of PES
11	RW	0	discard_av_package – for ts_recorder use only
10	RW	0	ts_recorder_select 0:after PID filter 1:before PID filter
9	RW	0	ts_recorder_enable
8	RW	0	(table_id == 0xff) means section_end
7	RW	0	do not send uncomplete section
6	RW	0	do not discard duplicate package
5	RW	0	search SOP when trasport_error_indicator
4	RW	0	stb demux enable
3	RW	0	do not reset state machine on SOP
2	RW	0	search SOP when error happened ( when ignore_fail_n_sop, will have this case)
1	RW	0	do not use SOP input ( check FEC sync byte instead )
0	RW	0	ignore fec_error bit when non sop ( check error on SOP only)

Table 9-26 FEC\_SYNC\_BYTE\_O 0x05

Bit(s)	R/W	Default	Description
15:8	RW	187	demux package length - 1 ( default : 187 )
7:0	RW	0	default is 0x47

Table 9-27 FM\_WR\_DATA\_O 0x06

Bit(s)	R/W	Default	Description
31:16	RW	0	filter memory write data hi[31:16]
15:0	RW	0	filter memory write data low [15:0]

**Table 9-28 FM\_WR\_ADDR\_O 0x07**

Bit(s)	R/W	Default	Description
31:24	RW	0	advanced setting hi
23:16	RW	0	advanced setting low
15	R	0	filter memory write data request
7:0	R	0	filter memory write addr

**Table 9-29 MAX\_FM\_COMP\_ADDR\_O 0x08**

Bit(s)	R/W	Default	Description
13:8	R	0	demux state – read only
7:4	RW	0	maxnum section filter compare address
3:0	RW	0	maxnum PID filter compare address

**Table 9-30 TS\_HEAD\_0\_O 0x09**

Bit(s)	R/W	Default	Description
15	RW	0	transport_error_indicator
14	RW	0	payload_unit_start_indicator
13	RW	0	transport_priority
12:00	RW	0	PID

**Table 9-31 TS\_HEAD\_1\_O 0x0a**

Bit(s)	R/W	Default	Description
7:6	R	0	transport_scrambling_control
5:4	R	0	adaptation_field_control
3:0	R	0	continuity_counter

**Table 9-32 OM\_CMD\_STATUS\_O 0x0b**

Bit(s)	R/W	Default	Description
15:12	R	0	om_cmd_count (read only)
11:9	R	0	overflow_count // bit 11:9 – om_cmd_wr_ptr (read only)
8:6	R	0	om_overwrite_count // bit 8:6 – om_cmd_rd_ptr (read only)
5:3	R	0	type_stb_om_w_rd (read only)
2	R	0	unit_start_stb_om_w_rd (read only)
1	R	0	om_cmd_overflow (read only)

Bit(s)	R/W	Default	Description
0	R	0	om_cmd_pending (read)
0	R	0	om_cmd_read_finished (write)

**Table 9-33 OM\_CMD\_DATA\_O 0x0c**

Bit(s)	R/W	Default	Description
15:9	R	0	count_stb_om_w_rd (read only)
8:0	R	0	start_stb_om_wa_rd (read only)

**Table 9-34 OM\_CMD\_DATA2\_O 0x0d**

Bit(s)	R/W	Default	Description
11:0	R	0	offset for section data

**Table 9-35 SEC\_BUFF\_01\_START\_O 0x0e**

Bit(s)	R/W	Default	Description
31:16	RW	0	base address for section buffer group 0 (*0x400 to get real address)
15:0	RW	0	base address for section buffer group 1 (*0x400 to get real address)

**Table 9-36 SEC\_BUFF\_23\_START\_O 0x0f**

Bit(s)	R/W	Default	Description
31:16	RW	0	base address for section buffer group 2 (*0x400 to get real address)
15:0	RW	0	base address for section buffer group 3 (*0x400 to get real address)

**Table 9-37 SEC\_BUFF\_SIZE\_O 0x10**

Bit(s)	R/W	Default	Description
3:0	RW	0	section buffer size for group 0 (bitused, for example, 10 means 1K)
7:4	RW	0	section buffer size for group 1
11:8	RW	0	section buffer size for group 2
15:12	RW	0	section buffer size for group 3

**Table 9-38 SEC\_BUFF\_BUSY\_O 0x11**

Bit(s)	R/W	Default	Description
31:0	R	0	Section buffer busy status for buff 31:0 (Read Only)

**Table 9-39 SEC\_BUFF\_READY\_O 0x12**

Bit(s)	R/W	Default	Description
31:0	RW	0	section buffer write status for buff 31:0 – Read clear buffer status ( buff READY and BUSY ) – write

**Table 9-40 SEC\_BUFF\_NUMBER\_O 0x13**

Bit(s)	R/W	Default	Description
4:0	RW	0	SEC_BUFFER_INDEX RW
12:8	RW	0	SEC_BUFFER_NUMBER for the INDEX buffer Read_Only
14	RW	0	output_section_buffer_valid
15	RW	0	section_reset_busy (Read Only)

**Table 9-41 ASSIGN\_PID\_NUMBER\_O 0x14**

Bit(s)	R/W	Default	Description
9:5	RW	0	BYPASS PID number
4:0	RW	0	PCR PID number

**Table 9-42 VIDEO\_STREAM\_ID\_O 0x15**

Bit(s)	R/W	Default	Description
31:16	RW	0	for video2
15:0	RW	0	stream_id filter Bit(s) enable

**Table 9-43 AUDIO\_STREAM\_ID\_O**

Bit(s)	R/W	Default	Description
15:0	RW	0	For audio

**Table 9-44 SUB\_STREAM\_ID\_O**

Bit(s)	R/W	Default	Description
15:0	RW	0	For sub

**Table 9-45 OTHER\_STREAM\_ID\_O**

Bit(s)	R/W	Default	Description
15:0	RW	0	For other

**Table 9-46 PCR90K\_CTL\_O 0x19**

Bit(s)	R/W	Default	Description
12	RW	0	PCR_EN
11:0	RW	0	PCR90K_DIV

**Table 9-47 PCR\_DEMUX\_O 0x1a**

Bit(s)	R/W	Default	Description
31:0	RW	0	PCR

**Table 9-48 VIDEO\_PTS\_DEMUX\_O 0x1b**

Bit(s)	R/W	Default	Description
31:0	RW	0	VPTS

**Table 9-49 VIDEO\_DTS\_DEMUX\_O 0x1c**

Bit(s)	R/W	Default	Description
31:0	RW	0	VDTS

**Table 9-50 AUDIO\_PTS\_DEMUX\_O 0x1d**

Bit(s)	R/W	Default	Description
31:0	RW	0	APTS

**Table 9-51 SUB\_PTS\_DEMUX\_O 0x1e**

Bit(s)	R/W	Default	Description
31:0	RW	0	SPTS

**Table 9-52 STB\_PTS\_DTS\_STATUS\_O 0x1f**

Bit(s)	R/W	Default	Description
15	R	0	SUB_PTS[32]
14	R	0	AUDIO_PTS[32]
13	R	0	VIDEO_DTS[32]
12	R	0	VIDEO_PTS[32]
3	R	0	sub_pts_ready
2	R	0	audio_pts_ready
1	R	0	video_dts_ready
0	R	0	video_pts_ready

**Table 9-53 STB\_DEBUG\_INDEX\_O 0x20**

Bit(s)	R/W	Default	Description
3	RW	0	pes_ctr_byte[7:0], pes_flag_byte[7:0]
2	RW	0	pes_package_bytes_left[15:0]
1	RW	0	stream_id[7:0], pes_header_bytes_left[7:0]
0	RW	0	adaptation_field_length[7:0], adaption_field_byte_1[7:0]

**Table 9-54 STB\_DEBUG\_DATAOUT\_O 0x21**

Bit(s)	R/W	Default	Description
15:0	R	0	Debug data out[15:0]

**Table 9-55 STB\_MOM\_CTL\_O 0x22**

Bit(s)	R/W	Default	Description
31	RW	0	no_match_record_en
30:16	RW	0	reserved
15:9	RW	0	MAX OM DMA COUNT (default: 0x40)
8:0	RW	0	LAST ADDR OF OM ADDR (default: 127)

**Table 9-56 STB\_INT\_STATUS\_O 0x23**

Bit(s)	R/W	Default	Description
12	R	0	INPUT_TIME_OUT
11	R	0	PCR_ready
10	R	0	audio_splicing_point
9	R	0	video_splicing_point
8	R	0	other_PES_int
7	R	0	sub_PES_int
6	R	0	discontinuity
5	R	0	duplicated_pack_found
4	R	0	New PDTS ready
3	R	0	om_cmd_buffer ready for access
2	R	0	section buffer ready
1	R	0	transport_error_indicator
0	R	0	TS ERROR PIN

**Table 9-57 DEMUX\_ENDIAN\_O 0x24**

Bit(s)	R/W	Default	Description
23:21	RW	0	demux om write endian control for OTHER_PES_PACKET
20:18	RW	0	demux om write endian control for SCR_ONLY_PACKET
17:15	RW	0	demux om write endian control for SUB_PACKET
14:12	RW	0	demux om write endian control for AUDIO_PACKET
11:9	RW	0	demux om write endian control for VIDEO_PACKET
8:6	RW	0	demux om write endian control for else
5:3	RW	0	demux om write endian control for bypass
2:0	RW	0	demux om write endian control for section

**Table 9-58 TS\_HIU\_CTL\_O 0x25**

Bit(s)	R/W	Default	Description
10:9	RW	0	PDTS_wr_sel: 0 select video_PDTS_wr_ptr; 1 select video_PDTS_wr_ptr_parser_B;
8:7	RW	0	use hi_bsf interface: 01: select hiu; 10 select hiu1
6:2	RW	0	fec_clk_div
1	RW	0	ts_source_sel
0	RW	0	Hiu TS generate enable

**Table 9-59 SEC\_BUFF\_BASE\_O 0x26**

Bit(s)	R/W	Default	Description
15:0	RW	0	base address for section buffer start (*0x10000 to get real base)

**Table 9-60 DEMUX\_MEM\_REQ\_EN\_O 0x27**

Bit(s)	R/W	Default	Description
11	RW	0	mask bit for OTHER_PES_AHB_DMA_EN
10	RW	0	mask bit for SUB_AHB_DMA_EN
9	RW	0	mask bit for BYPASS_AHB_DMA_EN
8	RW	0	mask bit for SECTION_AHB_DMA_EN
7	RW	0	mask bit for recoder stream
6:0	RW	0	mask bit for each type

**Table 9-61 VIDEO\_PDTS\_WR\_PTR\_O 0x28**

Bit(s)	R/W	Default	Description
31:0	RW	0	vb_wr_ptr for video PDTS



**Table 9-62 AUDIO\_PDTs\_WR\_PTR\_O 0x29**

Bit(s)	R/W	Default	Description
31:0	RW	0	ab_wr_ptr for video PDTs

**Table 9-63 SUB\_WR\_PTR\_O 0x2a**

Bit(s)	R/W	Default	Description
20:0	RW	0	SB_WRITE_PTR (sb_wr_ptr << 3 == byte write position)

**Table 9-64 SB\_START\_O 0x2b**

Bit(s)	R/W	Default	Description
19:0	RW	0	SB_START (sb_start << 12 == byte address);

**Table 9-65 SB\_LAST\_ADDR\_O 0x2c**

Bit(s)	R/W	Default	Description
20:0	RW	0	SB_SIZE (sb_size << 3 == byte size, 16M maximum)

**Table 9-66 SB\_PES\_WR\_PTR\_O 0x2d**

Bit(s)	R/W	Default	Description
31:0	RW	0	sb_wr_ptr for sub PES

**Table 9-67 OTHER\_WR\_PTR\_O 0x2e**

Bit(s)	R/W	Default	Description
31:21	RW	0	ob_wr_ptr for other PES
20:0	RW	0	OB_WRITE_PTR (ob_wr_ptr << 3 == byte write position)

**Table 9-68 OB\_START\_O 0x2f**

Bit(s)	R/W	Default	Description
19:0	RW	0	OB_START (ob_start << 12 == byte address);

**Table 9-69 OB\_LAST\_ADDR\_O 0x30**

Bit(s)	R/W	Default	Description
20:0	RW	0	OB_SIZE (ob_size << 3 == byte size, 16M maximum)

**Table 9-70 OB\_PES\_WR\_PTR\_O 0x31**

Bit(s)	R/W	Default	Description
31:0	RW	0	ob_wr_ptr for sub PES

**Table 9-71 STB\_INT\_MASK\_O 0x32**

Bit(s)	R/W	Default	Description
9	RW	0	splicing_point
8	RW	0	other_PES_int
7	RW	0	sub_PES_int
6	RW	0	discontinuity
5	RW	0	duplicated_pack_found
4	RW	0	New PDTS ready
3	RW	0	om_cmd_buffer ready for access
2	RW	0	section buffer ready
1	RW	0	transport_error_indicator
0	RW	0	TS ERROR PIN

**Table 9-72 VIDEO\_SPLICING\_CTL\_O 0x33**

Bit(s)	R/W	Default	Description
15	RW	0	splicing VIDEO PID change enable
14:10	RW	0	VIDEO PID FILTER ADDRESS
9	RW	0	PES splicing active (Read Only)
8	RW	0	splicing active (Read Only)
7:0	RW	0	splicing countdown (Read Only)

**Table 9-73 AUDIO\_SPLICING\_CTL\_O 0x34**

Bit(s)	R/W	Default	Description
15	RW	0	splicing AUDIO PID change enable
14:10	RW	0	AUDIO PID FILTER ADDRESS
9	RW	0	PES splicing active (Read Only)
8	RW	0	splicing active (Read Only)
7:0	RW	0	splicing countdown (Read Only)

Table 9-74 TS\_PACKAGE\_BYTE\_COUNT\_O 0x35

Bit(s)	R/W	Default	Description
23:16	RW	0	M2TS_SKIP_BYTES
15:8	RW	0	LAST TS PACKAGE BYTE COUNT (Read Only)
7:0	RW	0	PACKAGE BYTE COUNT (Read Only)

Table 9-75 PES\_STRONG\_SYNC\_O 0x36

Bit(s)	R/W	Default	Description
15:0	RW	0	2 bytes strong sync add to PES

Table 9-76 OM\_DATA\_RD\_ADDR\_O 0x37

Bit(s)	R/W	Default	Description
15	RW	0	stb_om_ren
14:11	RW	0	reserved
10:0	RW	0	OM_DATA_RD_ADDR

Table 9-77 OM\_DATA\_RD\_O 0x38

Bit(s)	R/W	Default	Description
15:0	RW	0	OM_DATA_RD

Table 9-78 SECTION\_AUTO\_STOP\_3\_O 0x39

Bit(s)	R/W	Default	Description
31	RW	0	Auto stop count 31 Wr_en
30:28	RW	0	Auto stop count 31
27	RW	0	Auto stop count 30 Wr_en
26:24	RW	0	Auto stop count 30
23	RW	0	Auto stop count 29 Wr_en
22:20	RW	0	Auto stop count 29
19	RW	0	Auto stop count 28 Wr_en
18:16	RW	0	Auto stop count 28
15	RW	0	Auto stop count 27 Wr_en
14:12	RW	0	Auto stop count 27
11	RW	0	Auto stop count 26 Wr_en
10:8	RW	0	Auto stop count 26
7	RW	0	Auto stop count 25 Wr_en
6:4	RW	0	Auto stop count 25

Bit(s)	R/W	Default	Description
3	RW	0	Auto stop count 24 Wr_en
2:0	RW	0	Auto stop count 24

Table 9-79 SECTION\_AUTO\_STOP\_2\_O 0x3a

Bit(s)	R/W	Default	Description
31	RW	0	Auto stop count 23 Wr_en
30:28	RW	0	Auto stop count 23
27	RW	0	Auto stop count 22 Wr_en
26:24	RW	0	Auto stop count 22
23	RW	0	Auto stop count 21 Wr_en
22:20	RW	0	Auto stop count 21
19	RW	0	Auto stop count 20 Wr_en
18:16	RW	0	Auto stop count 20
15	RW	0	Auto stop count 19 Wr_en
14:12	RW	0	Auto stop count 19
11	RW	0	Auto stop count 18 Wr_en
10:8	RW	0	Auto stop count 18
7	RW	0	Auto stop count 17 Wr_en
6:4	RW	0	Auto stop count 17
3	RW	0	Auto stop count 16 Wr_en
2:0	RW	0	Auto stop count 16

Table 9-80 SECTION\_AUTO\_STOP\_1\_O 0x3b

Bit(s)	R/W	Default	Description
31	RW	0	Auto stop count 15 Wr_en
30:28	RW	0	Auto stop count 15
27	RW	0	Auto stop count 14 Wr_en
26:24	RW	0	Auto stop count 14
23	RW	0	Auto stop count 13 Wr_en
22:20	RW	0	Auto stop count 13
19	RW	0	Auto stop count 12 Wr_en
18:16	RW	0	Auto stop count 12
15	RW	0	Auto stop count 11 Wr_en
14:12	RW	0	Auto stop count 11
11	RW	0	Auto stop count 10 Wr_en

Bit(s)	R/W	Default	Description
10:8	RW	0	Auto stop count 10
7	RW	0	Auto stop count 9 Wr_en
6:4	RW	0	Auto stop count 9
3	RW	0	Auto stop count 8 Wr_en
2:0	RW	0	Auto stop count 8

Table 9-81 SECTION\_AUTO\_STOP\_0\_O 0x3c

Bit(s)	R/W	Default	Description
31	RW	0	Auto stop count 7 Wr_en
30:28	RW	0	Auto stop count 7
27	RW	0	Auto stop count 6 Wr_en
26:24	RW	0	Auto stop count 6
23	RW	0	Auto stop count 5 Wr_en
22:20	RW	0	Auto stop count 5
19	RW	0	Auto stop count 4 Wr_en
18:16	RW	0	Auto stop count 4
15	RW	0	Auto stop count 3 Wr_en
14:12	RW	0	Auto stop count 3
11	RW	0	Auto stop count 2 Wr_en
10:8	RW	0	Auto stop count 2
7	RW	0	Auto stop count 1 Wr_en
6:4	RW	0	Auto stop count 1
3	RW	0	Auto stop count 0 Wr_en
2:0	RW	0	Auto stop count 0

Table 9-82 DEMUX\_CHANNEL\_RESET\_O 0x3d

Bit(s)	R/W	Default	Description
31:0	R	0	Bit 31:0 reset channel status - Each Bit reset each channel

Table 9-83 DEMUX\_SCRAMBLING\_STATE\_O 0x3e

Bit(s)	R/W	Default	Description
31:0	R	0	Scrambling state of each channel

**Table 9-84 DEMUX\_CHANNEL\_ACTIVITY\_O 0x3f**

Bit(s)	R/W	Default	Description
31:0	R	0	Channel activity of each channel

**Table 9-85 DEMUX\_STAMP\_CTL\_O 0x40**

Bit(s)	R/W	Default	Description
4	RW	0	video_stamp_use_dts
3	RW	0	audio_stamp_sync_1_en
2	RW	0	audio_stamp_insert_en
1	RW	0	video_stamp_sync_1_en
0	RW	0	video_stamp_insert_en

**Table 9-86 DEMUX\_VIDEO\_STAMP\_SYNC\_0\_O**

Bit(s)	R/W	Default	Description
31:0	RW	0	Video stamp sync [63:32]

**Table 9-87 DEMUX\_VIDEO\_STAMP\_SYNC\_1\_O**

Bit(s)	R/W	Default	Description
31:0	RW	0	Video stamp sync [31:0]

**Table 9-88 DEMUX\_AUDIO\_STAMP\_SYNC\_0\_O**

Bit(s)	R/W	Default	Description
31:0	RW	0	Aideo stamp sync [63:32]

**Table 9-89 DEMUX\_AUDIO\_STAMP\_SYNC\_1\_O**

Bit(s)	R/W	Default	Description
31:0	RW	0	Aideo stamp sync [31:0]

**Table 9-90 DEMUX\_SECTION\_RESET\_O**

Bit(s)	R/W	Default	Description
31:0	R	0	Write : Bit[4:0] secter filter number for reset Read : select according to output_section_buffer_valid: per bit per section buffer valid status or section_buffer_ignore

**Table 9-91 DEMUX\_INPUT\_TIMEOUT\_C\_O**

Bit(s)	R/W	Default	Description
31:0	RW	0	channel_reset_timeout_disable

**Table 9-92 DEMUX\_INPUT\_TIMEOUT\_O 0x47**

Bit(s)	R/W	Default	Description
31	RW	0	no_match_reset_timeout_disable
30:0	RW	0	input_time_out_int_cnt (0 – means disable) Wr-setting, Rd-count

**Table 9-93 DEMUX\_PACKET\_COUNT\_O 0x48**

Bit(s)	R/W	Default	Description
31:0	RW	0	channel_packet_count_disable

**Table 9-94 DEMUX\_PACKET\_COUNT\_C\_O**

Bit(s)	R/W	Default	Description
31	RW	0	no_match_packet_count_disable
30:0	RW	0	input_packet_count

**Table 9-95 DEMUX\_CHAN\_RECORD\_EN\_O**

Bit(s)	R/W	Default	Description
31:0	RW	0xffffffff	channel_record_enable

**Table 9-96 DEMUX\_CHAN\_PROCESS\_EN\_O**

Bit(s)	R/W	Default	Description
31:0	RW	0xffffffff	channel_process_enable

**Table 9-97 DEMUX\_SMALL\_SEC\_CTL\_O 0x4c**

Bit(s)	R/W	Default	Description
31:24	RW	0	small_sec_size ((n+1) * 256 Bytes)
23:16	RW	0	small_sec_rd_ptr
15:8	RW	0	small_sec_wr_ptr
7:2	RW	0	reserved
1	RW	0	small_sec_wr_ptr_wr_enable
0	RW	0	small_section_enable

## 9.2 Video Output

### 9.2.1 Overview

This section describes the SoC's VPU sub-module, including RDMA sub-module, VIU sub-module, HDMITX sub-module, CVBS sub-module .

### 9.2.2 VPU

VPU is display process unit, the main function is to receive data from decoder/ddr/hdmirx etc, then process the source data in order to get the high-quality video picture, and finally send out the video to the screen by HDMITX/CVBS etc.

### 9.2.3 Register Description

#### 9.2.3.1 VPU Registers

Table 9-98 VPU\_OSD1\_MMC\_CTRL 0x2701

Bit(s)	R/W	Default	Description
12	R/W	0	OSD1_V2: Select which mmc_pre_arb for VIU1_OSD1 DDR request. 0: Select vdisp_mmc_arb 1: Select v2disp_mmc_arb
11-6	R/W	0x3f	OSD1_NUM: mmc_pre_arb burst num.
5-0	R/W	0x3f	OSD1_ID: mmc_pre_arb thread ID.

Table 9-99 VPU\_OSD2\_MMC\_CTRL 0x2702

Bit(s)	R/W	Default	Description
12	R/W	0	OSD2_V2: Select which mmc_pre_arb for VIU1_OSD2 DDR request. 0: Select vdisp_mmc_arb 1: Select v2disp_mmc_arb
11-6	R/W	0x3f	OSD2_NUM: mmc_pre_arb burst num.
5-0	R/W	0x3e	OSD2_ID: mmc_pre_arb thread ID.

Table 9-100 VPU\_VD1\_MMC\_CTRL 0x2703

Bit(s)	R/W	Default	Description
12	R/W	1	VD1_MMC_PRE_ARB_SEL: Select which mmc_pre_arb for VIU1_VD1 DDR request. 0: Select vdisp_mmc_arb 1: Select vdin_mmc_arb
11-6	R/W	0x3f	VD1_NUM: mmc_pre_arb burst num.
5-0	R/W	0x3d	VD1_ID: mmc_pre_arb thread ID.



**Table 9-101 VPU\_VD2\_MMC\_CTRL 0x2704**

Bit(s)	R/W	Default	Description
12	R/W	1	VD2_MMC_PRE_ARB_SEL: Select which mmc_pre_arb for VIU1_VD2 DDR request. 0: Select vdisp_mmc_arb 1: Select vdin_mmc_arb
11-6	R/W	0x3f	VD2_NUM: mmc_pre_arb burst num.
5-0	R/W	0x3c	VD2_ID: mmc_pre_arb thread ID.

**Table 9-102 VPU\_DI\_IF1\_MMC\_CTRL 0x2705**

Bit(s)	R/W	Default	Description
12	R/W	1	DI_IF1_MMC_PRE_ARB_SEL: Select which mmc_pre_arb for DI_IF1 DDR request. 0: Select vdisp_mmc_arb 1: Select vdin_mmc_arb
11-6	R/W	0x3f	DI_IF1_NUM: mmc_pre_arb burst num.
5-0	R/W	0x3b	DI_IF1_ID: mmc_pre_arb thread ID.

**Table 9-103 VPU\_DI\_MEM\_MMC\_CTRL 0x2706**

Bit(s)	R/W	Default	Description
12	R/W	1	DI_MEM_MMC_PRE_ARB_SEL: Select which mmc_pre_arb for DI_MEM DDR request. 0: Select vdisp_mmc_arb 1: Select vdin_mmc_arb
11-6	R/W	0x3f	DI_MEM_NUM: mmc_pre_arb burst num.
5-0	R/W	0x3a	DI_MEM_ID: mmc_pre_arb thread ID.

**Table 9-104 VPU\_DI\_INP\_MMC\_CTRL 0x2707**

Bit(s)	R/W	Default	Description
12	R/W	1	DI_INP_MMC_PRE_ARB_SEL: Select which mmc_pre_arb for DI_INP DDR request. 0: Select vdisp_mmc_arb 1: Select vdin_mmc_arb
11-6	R/W	0x3f	DI_INP_NUM: mmc_pre_arb burst num.
5-0	R/W	0x39	DI_INP_ID: mmc_pre_arb thread ID.

**Table 9-105 VPU\_DI\_MTNRD\_MMC\_CTRL 0x2708**

Bit(s)	R/W	Default	Description
12	R/W	1	DI_MTNRD_MMC_PRE_ARB_SEL: Select which mmc_pre_arb for DI_MTNRD DDR request. 0: Select vdisp_mmc_arb 1: Select vdin_mmc_arb
11-6	R/W	0x3f	DI_MTNRD_NUM: mmc_pre_arb burst num.
5-0	R/W	0x38	DI_MTNRD_ID: mmc_pre_arb thread ID.

**Table 9-106 VPU\_DI\_CHAN2\_MMC\_CTRL 0x2709**

Bit(s)	R/W	Default	Description
12	R/W	1	DI_CHAN2_MMC_PRE_ARB_SEL: Select which mmc_pre_arb for DI_CHAN2 DDR request. 0: Select vdisp_mmc_arb 1: Select vdin_mmc_arb
11-6	R/W	0x3f	DI_CHAN2_NUM: mmc_pre_arb burst num.
5-0	R/W	0x37	DI_CHAN2_ID: mmc_pre_arb thread ID.

**Table 9-107 VPU\_DI\_MTNWR\_MMC\_CTRL 0x270a**

Bit(s)	R/W	Default	Description
12	R/W	1	DI_MTNWR_MMC_PRE_ARB_SEL: Select which mmc_pre_arb for DI_MTNWR DDR request. 0: Select vdisp_mmc_arb 1: Select vdin_mmc_arb
11-6	R/W	0x3f	DI_MTNWR_NUM: mmc_pre_arb burst num.
5-0	R/W	0x36	DI_MTNWR_ID: mmc_pre_arb thread ID.

**Table 9-108 VPU\_DI\_NRWR\_MMC\_CTRL 0x270b**

Bit(s)	R/W	Default	Description
12	R/W	1	DI_NRWR_MMC_PRE_ARB_SEL: Select which mmc_pre_arb for DI_NRWR DDR request. 0: Select vdisp_mmc_arb 1: Select vdin_mmc_arb
11-6	R/W	0x3f	DI_NRWR_NUM: mmc_pre_arb burst num.
5-0	R/W	0x35	DI_NRWR_ID: mmc_pre_arb thread ID.

**Table 9-109 VPU\_DI\_DIWR\_MMC\_CTRL 0x270c**

Bit(s)	R/W	Default	Description
12	R/W	1	DI_DIWR_MMC_PRE_ARB_SEL: Select which mmc_pre_arb for DI_DIWR DDR request. 0: Select vdisp_mmc_arb 1: Select vdin_mmc_arb
11-6	R/W	0x3f	DI_DIWR_NUM: mmc_pre_arb burst num.
5-0	R/W	0x34	DI_DIWR_ID: mmc_pre_arb thread ID.

VIN0\_WR module connects to vdin\_mmc\_arb.

**Table 9-110 VPU\_VDIN0\_MMC\_CTRL 0x270d**

Bit(s)	R/W	Default	Description
11-6	R/W	0x3f	VDIN0_WR_NUM: mmc_pre_arb burst num.
5-0	R/W	0x33	VDIN0_WR_ID: mmc_pre_arb thread ID.

VIN1\_WR module connects to vdin\_mmc\_arb.

**Table 9-111 VPU\_VDIN1\_MMC\_CTRL 0x270e**

Bit(s)	R/W	Default	Description
11-6	R/W	0x3f	VDIN1_WR_NUM: mmc_pre_arb burst num.
5-0	R/W	0x32	VDIN1_WR_ID: mmc_pre_arb thread ID.

BT656 module connects to vdin\_mmc\_arb.

**Table 9-112 VPU\_BT656\_MMC\_CTRL 0x270f**

Bit(s)	R/W	Default	Description
11-6	R/W	0x3f	BT656_NUM: mmc_pre_arb burst num.
5-0	R/W	0x31	BT656_ID: mmc_pre_arb thread ID.

**Table 9-113 VPU\_VDIN\_PRE\_ARB\_CTRL 0x2714**

Bit(s)	R/W	Default	Description
31	R/W	0	VDIN_PREARB_SOFT_RESET: 1=SW reset vdin_mmc_pre_arb.
30-18	R	0	Reserved.
17	R/W	1	VDIN_ACG_EN: 1=Enable auto-clock gating of vdin_mmc_pre_arb.
16	R/W	0	VDIN_DISABLE_CLK: 1=Disalbe the clock to vdin_mmc_pre_arb.
15-0	R/W	0xffff	VDIN_REQ_EN: vdin_mmc_pre_arb request enable.

**Table 9-114 VPU\_VDISP\_PRE\_ARB\_CTRL 0x2715**

Bit(s)	R/W	Default	Description
31	R/W	0	VDISP_PREARB_SOFT_RESET: 1=SW reset vdisp_mmc_pre_arb.
30-18	R	0	Reserved.
17	R/W	1	VDISP_ACG_EN: 1=Enable auto-clock gating of vdisp_mmc_pre_arb.
16	R/W	0	VDISP_DISABLE_CLK: 1=Disalbe the clock to vdisp_mmc_pre_arb.
15-0	R/W	0xffff	VDISP_REQ_EN: vdisp_mmc_pre_arb request enable.

**Table 9-115 VPU\_VPUARB2\_PRE\_ARB\_CTRL 0x2716**

Bit(s)	R/W	Default	Description
31	R/W	0	VPUARB2_PREARB_SOFT_RESET: 1=SW reset vpuarb2_mmc_pre_arb.
30-18	R	0	Reserved.
17	R/W	1	VPUARB2_ACG_EN: 1=Enable auto-clock gating of vpuarb2_mmc_pre_arb.
16	R/W	0	VPUARB2_DISABLE_CLK: 1=Disalbe the clock to vpuarb2_mmc_pre_arb.
15-0	R/W	0xffff	VPUARB2_REQ_EN: vpuarb2_mmc_pre_arb request enable.

**Table 9-116 VPU\_OSD3\_MMC\_CTRL 0x2717**

Bit(s)	R/W	Default	Description
13-12	R/W	0	OSD3_MMC_PRE_ARB_SEL: Select which mmc_pre_arb for VIU2_OSD1 DDR request. 0: Select v2disp_mmc_arb 1: Select vdisp_mmc_arb 2: Select vdin_mmc_arb
11-6	R/W	0x3f	OSD3_NUM: mmc_pre_arb burst num.
5-0	R/W	0x2e	OSD3_ID: mmc_pre_arb thread ID.

**Table 9-117 VPU\_OSD4\_MMC\_CTRL 0x2718**

Bit(s)	R/W	Default	Description
13-12	R/W	0	OSD4_MMC_PRE_ARB_SEL: Select which mmc_pre_arb for VIU2_OSD1 DDR request. 0: Select v2disp_mmc_arb 1: Select vdisp_mmc_arb 2: Select vdin_mmc_arb
11-6	R/W	0x3f	OSD4_NUM: mmc_pre_arb burst num.
5-0	R/W	0x2d	OSD4_ID: mmc_pre_arb thread ID.

**Table 9-118 VPU\_VD3\_MMC\_CTRL 0x2719**

Bit(s)	R/W	Default	Description
13-12	R/W	0	VD3_MMC_PRE_ARB_SEL: Select which mmc_pre_arb for VIU2_VD1 DDR request. 0: Select v2disp_mmc_arb 1: Select vdisp_mmc_arb 2: Select vdin_mmc_arb
11-6	R/W	0x3f	VD3_NUM: mmc_pre_arb burst num.
5-0	R/W	0x2c	VD3_ID: mmc_pre_arb thread ID.

**Table 9-119 VPU\_VIU\_VENC\_MUX\_CTRL 0x271a**

Bit(s)	R/W	Default	Description
20	R/W	0	Viu_sync_mode_en 1:Viu_sync_mode_en enable// ENCL/P/I vsync send to both viu1 and viu2 Bit[1:0] select data fbettwen viu1 and ENCL/P/I Bit[5:4] select ctrl singlar(vsync) bettween ENCL/P/I and viu1. Bit[3:2] select data and vsync bettween viu2 and ENCL/P/I 0:Viu_sync_mode_en disable// Bit[1:0] select data and vsync fbettwen viu1 and ENCL/P/I Bit[3:2] select data and vsync bettween viu2 and ENCL/P/I Bit[5:4] unuse
17-16	W	0	RASP DPI CLOCK SEL : 00 : cph1 01 : cph2 10/11 : cph3
15:6	W	0	reserved
5-4			VIU1_SEL_VENC_CTRL: Select which one of the encl/P/T/L control singlar that Viu1 connects to when viu_sync_model enable.unuse when viu_sync_model disable. 0: ENCL 1: ENCI 2: ENCP 3: ENCT
3-2	R/W	0	VIU2_SEL_VENC: Select which one of the encl/P/T/L that Viu2 connects to (both vsync and data). 0: ENCL 1: ENCI 2: ENCP 3: ENCT
1-0	R/W	0	VIU1_SEL_VENC: Select which one of the encl/P/T/L that Viu1 connects to. Only select data when viu_sync_model enable,select both data and vsync when viu_sync_model disable, 0: ENCL 1: ENCI 2: ENCP 3: ENCT

**Table 9-120 VPU\_HDMI\_SETTING 0x271b**

Bit(s)	R/W	Default	Description
15-12	R/W	0	RD_RATE: Read rate to the async FIFO between VENC and HDMI. 0: One read every rd_clk 1: One read every 2 rd_clk 2: One read every 3 rd_clk ... 15: One read every 16 rd_clk
11-8	R/W	0	WR_RATE: Write rate to the async FIFO between VENC and HDMI. 0: One write every wr_clk

Bit(s)	R/W	Default	Description
			1: One write every 2 wr_clk 2: One write every 3 wr_clk ... 15: One write every 16 wr_clk
7-5	R/W	0	DATA_COMP_MAP: Input data is CrYCr(BRG), map the output data to desired format: 0: output CrYCb (BRG) 1: output YCbCr (RGB) 2: output YCrCb (RBG) 3: output CbCrY (GBR) 4: output CbYCr (GRB) 5: output CrCbY (BGR) 6,7: Reserved
4	R/W	0	INV_DVI_CLK: If true, invert the polarity of clock output to external DVI interface. (NOT internal HDMI).
3	R/W	0	INV_VSYNC: If true, invert the polarity of VSYNC input from VENC
2	R/W	0	INV_HSYNC: If true, invert the polarity of HSYNC input from VENC
1-0	R/W	0	SRC_SEL: Select which HDMI source from between ENCI and ENCP. 2'b00: Disable HDMI source 2'b01: Select ENCI data to HDMI 2'b10: Select ENCP data to HDMI

Table 9-121 ENCI\_INFO\_READ 0x271c

Bit(s)	R/W	Default	Description
31-29	R	0	Current ENCI field status.
28-25	R	0	Reserved
24-16	R	0	Current ENCI line counter status.
15-11	R	0	Reserved
10-0	R	0	Current ENCI pixel counter status.

Table 9-122 ENCP\_INFO\_READ 0x271d

Bit(s)	R/W	Default	Description
31-29	R	0	Current ENCP field status.
28-16	R	0	Current ENCP line counter status.
15-13	R	0	Reserved
12-0	R	0	Current ENCP pixel counter status.

Table 9-123 ENCT\_INFO\_READ 0x271e

Bit(s)	R/W	Default	Description
31-29	R	0	Current ENCT field status.
28-16	R	0	Current ENCT line counter status.
15-13	R	0	Reserved
12-0	R	0	Current ENCT pixel counter status.

**Table 9-124 ENCL\_INFO\_READ 0x271f**

Bit(s)	R/W	Default	Description
31-29	R	0	Current ENCL field status.
28-16	R	0	Current ENCL line counter status.
15-13	R	0	Reserved
12-0	R	0	Current ENCL pixel counter status.

**Table 9-125 VPU\_SW\_RESET 0x2720**

Bit(s)	R/W	Default	Description
3	R/W	0	vpuarb2_mmc_arb_rst_n
2	R/W	0	vdisp_mmc_arb_rst_n
1	R/W	0	vdin_mmc_arb_rst_n
0	R/W	0	viu_rst_n

**Table 9-126 VPU\_D2D3\_MMC\_CTRL 0x2721**

Bit(s)	R/W	Default	Description
30	R/W	0	d2d3_depr_req_sel, 0:vdisp_pre_arb, 1: vpuarb2_pre_arb
27-22	R/W	0x3f	d2d3_depr_brst_num
21-16	R/W	0x2d	d2d3_depr_id
14	R/W	0x0	d2d3_depwr_req_sel, 0: vdin_pre_arb, 1: vdisp_pre_arb
11-6	R/W	0x3f	d2d3_depwr_brst_num
5-0	R/W	0x2e	d2d3_depwr_id

**Table 9-127 VPU\_CONT\_MMC\_CTRL 0x2722**

Bit(s)	R/W	Default	Description
30	R/W	0x0	mtn_contrd_req_sel, 0:vdisp_post_arb, 1: vpuarb2_pre_arb
27-22	R/W	0x3f	mtn_contrd_brst_num
21-16	R/W	0x2b	mtn_contrd_id
14	R/W	0x0	mtn_contwr_req_sel, 0: vdisp_post_arb, 1: vpuarb2_pre_arb
11-6	R/W	0x3f	mtn_contwr_brst_num
5-0	R/W	0x2c	mtn_contwr_id

**Table 9-128 VPU\_CLK\_GATE 0x2723**

Bit(s)	R/W	Default	Description
30-18	R/W	0x0	Reserved
17	R/W	0x1	Clk_b control register no latch
16	R/W	0x1	Clk_vib enable
15	R/W	0x1	Gvapbclk enable
14	R/W	0x1	Clk mpeg vlock enable
13	R/W	0x1	Reserved
12	R/W	0x1	Venc_dac_process_clk enable
11	R/W	0x1	Venc_i_top enable
10	R/W	0x1	Venci_int enable
9:8	R/W	0x11	Clk_vib latch sync source select 00: di2ldim_go_field, 01: post_frame_rst;10: pre_frame_rst, 11:viu_go_field
7	R/W	0x1	Reserved
6	R/W	0x1	Vpu_misc_clk enable
5	R/W	0x1	Venc_l_top enable
4	R/W	0x1	Venc_l_int enable
3	R/W	0x1	Venc_p_int enable
2	R/W	0x1	Reserved
1	R/W	0x1	Vi_top clock enable
0	R/W	0x1	Venc_p_top enable

**Table 9-129 VPU\_HDMI\_DATA\_OVR 0x2727**

Bit(s)	R/W	Default	Description
31	R/W	0	DATA_OVR_EN: Control if override HDMI input data with DATA_OVR[29:0], for display e.g. black or blue screen. 0: No override 1: Enable override
30	R	0	Reserved
29-0	R/W	0	DATA_OVR: programmable pixel data value for override.

**Table 9-130 VPU\_VPU\_PWM\_V0 0x2730**

Bit(s)	R/W	Default	Description
31	R/W	0	reg_vpu_pwm_inv, 1: invert the pwm signal, active low
30-29	R/W	0	reg_vpu_pwm_src_sel, 00: encl, enct, encp
28-16	R/W	0	reg_vpu_pwm_v_end0
15-14	R/W	0	reg_vpu_pwm_setting_latch_mode
13	R/W	1	reg_vpu_pwm_vs_inv
12-0	R/W	0	reg_vpu_pwm_v_start0



**Table 9-131 VPU\_VPU\_PWM\_V1 0x2731**

Bit(s)	R/W	Default	Description
28-16	R/W	0	reg_vpu_pwm_v_end1
12-0	R/W	0	reg_vpu_pwm_v_start1

**Table 9-132 VPU\_VPU\_PWM\_V2 0x2732**

Bit(s)	R/W	Default	Description
28-16	R/W	0	reg_vpu_pwm_v_end2
12-0	R/W	0	reg_vpu_pwm_v_start2

**Table 9-133 VPU\_VPU\_PWM\_V3 0x2733**

Bit(s)	R/W	Default	Description
28-16	R/W	0	reg_vpu_pwm_v_end3
12-0	R/W	0	reg_vpu_pwm_v_start3

**Table 9-134 VPU\_VPU\_PWM\_H0 0x2734**

Bit(s)	R/W	Default	Description
28-16	R/W	0	reg_vpu_pwm_h_end0
12-0	R/W	0	reg_vpu_pwm_h_start0

**Table 9-135 VPU\_VPU\_PWM\_H1 0x2735**

Bit(s)	R/W	Default	Description
28-16	R/W	0	reg_vpu_pwm_h_end1
12-0	R/W	0	reg_vpu_pwm_h_start1

**Table 9-136 VPU\_VPU\_PWM\_H2 0x2736**

Bit(s)	R/W	Default	Description
28-16	R/W	0	reg_vpu_pwm_h_end2
12-0	R/W	0	reg_vpu_pwm_h_start2

**Table 9-137 VPU\_VPU\_PWM\_H3 0x2737**

Bit(s)	R/W	Default	Description
28-16	R/W	0	reg_vpu_pwm_h_end3
12-0	R/W	0	reg_vpu_pwm_h_start3

**Table 9-138 VPU\_VPU\_3D\_SYNC1 0x2738**

Bit(s)	R/W	Default	Description
31	R/W	0	reg_3dsync_enable, 1: enable 3d sync output
30	R/W	0	3dsync setting vsync latch
29	R/W	0	3dsync go high field polarity: 1, go high while field[0]=1
28-16	R/W	0	reg_3dsync_v_end0
15	R/W	0	3dsync out inv
14	R/W	0	3dsync vbo out inv
13	R/W	1	Vbo 3d en, to v by one, 3d enable
12-0	R/W	0	reg_3dsync_v_start0

**Table 9-139 VPU\_VPU\_3D\_SYNC2 0x2739**

Bit(s)	R/W	Default	Description
31	R/W	0	Reg_3dsync_field_bit_sel: 1. Keep 3dsync not changed for two fields, i.e. L-L-R-R-L-L-R-R (11001100) 0. Change 3dsync every field i.e. L-R-L-R (1010)
28-16	R/W	0	reg_3dsync_h_end
12-0	R/W	0	reg_3dsync_h_start

12 bit to 10 bit dither control register. 10 bit to 8 bit see VPU\_HDMI\_DITH\_CNTL

**Table 9-140 VPU\_HDMI\_FMT\_CTRL 0x2743**

Bit(s)	R/W	Default	Description
21-19	R/W	0	frame count offset for B
18-16	R/W	0	frame count offset for G
15	R/W	0	hcnt hold when de valid
14	R/W	0	RGB frame count separate
13	R/W	0	dith4x4 : frame random enable
12	R/W	0	dith4x4 enable
11	R/W	0	tunnel enable for DOLBY
10	R/W	0	rounding enable
9-6	R/W	0	Cntl_hdmi_dith10 :
5	R/W	0	Cntl_hdmi_dith_md:
4	R/W	0	Cntl_hdmi_dith_en: dither 10-b to 8-b enable

Bit(s)	R/W	Default	Description
3-2	R/W	0	Cntl_chroma_dnsmpl: Chroma down sample mode when convert to 422 or 420. 0 = use pixel 0; 1 = use pixel 1; 2 = use average;
1-0	R/W	0	Cntl_hdmi_vid_fmt: Control whether to convert ENCP's 444 data to 422 or 420 0 = No conversion; 1 = Convert to 422; 2 = Convert to 420;

Table 9-141 VPU\_VDIN\_ASYNC\_HOLD\_CTRL 0x2744

Bit(s)	R/W	Default	Description
31-24	R/W	'h18	Wr_hold_num
23-16	R/W	'h10	Wr_rel_num
15-8	R/W	'h18	Rd_hold_num
7-0	R/W	'h10	Rd_rel_num

Table 9-142 VPU\_VDISP\_ASYNC\_HOLD\_CTRL 0x2745

Bit(s)	R/W	Default	Description
31-24	R/W	'h18	Wr_hold_num
23-16	R/W	'h10	Wr_rel_num
15-8	R/W	'h18	Rd_hold_num
7-0	R/W	'h10	Rd_rel_num

Table 9-143 VPU\_VPUARB2\_ASYNC\_HOLD\_CTRL 0x2746

Bit(s)	R/W	Default	Description
31-24	R/W	'h18	Wr_hold_num
23-16	R/W	'h10	Wr_rel_num
15-8	R/W	'h18	Rd_hold_num
7-0	R/W	'h10	Rd_rel_num

Table 9-144 VPU\_ARB\_URG\_CTRL 0x2747

Bit(s)	R/W	Default	Description
11	R/W	0	Rdma_ddr_reg_busy to vpuarb2_urg_ctrl
10	R/W	0	Rdma_ddr_reg_busy to vdisp_urg_ctrl
9	R/W	0	Rdma_ddr_reg_busy to vdin_urg_ctrl
8	R/W	0	Vdin1_1ff_urg_ctrl to vpuarb2_urg_ctrl
7	R/W	0	Vdin0_1ff_urg_ctrl to vpuarb2_urg_ctrl

Bit(s)	R/W	Default	Description
6	R/W	0	Vpp_off_urg_ctrl to vpuarb2_urg_ctrl
5	R/W	0	Vdin1_lff_urg_ctrl to vdisp_urg_ctrl
4	R/W	0	Vdin0_lff_urg_ctrl to vdisp_urg_ctrl
3	R/W	0	Vpp_off_urg_ctrl to vdisp_urg_ctrl
2	R/W	0	Vdin1_lff_urg_ctrl to vdin_urg_ctrl
1	R/W	0	Vdin0_lff_urg_ctrl to vdin_urg_ctrl
0	R/W	0	Vpp_off_urg_ctrl to vdin_urg_ctrl

Table 9-145 VPU\_VENCL\_DITH\_EN 0x2749

R/W	Default	Description
R/W	0	dith_en //dith between vpp and encl_int
R/W	0	dith_hsize

Table 9-146 VPU\_422TO444\_RST 0x274a

Bit(s)	R/W	Default	Description
3	R/W	0	Change output of viu_12bit422to10bit444_vd1 to 10bits 1:cut high 2 bits 0:cut low 2 bits
2	R/W	0	Change output of viu_12bit422to10bit444_encp to 10bits 1:cut high 2 bits 0:cut low 2 bits
1	R/W	0	Soft rst enable of viu_12bit422to10bit444_vd1 module active high
0	R/W	0	Soft rst enable of viu_12bit422to10bit444_encp module active high

Table 9-147 VPU\_422TO444\_CTRL0 0x274b

Bit(s)	R/W	Default	Description
31	R/W	0	bypass_mode : active high if this bit set high ,viu_12bit422to10bit444_encp work in bypass mode, dout = din
30	/	/	reversed
29	R/W	0	clip10_mode: active high if this bit set high ,viu_12bit422to10bit444_encp work clip10_mode ,output high 10bits value of din and clip data to 10bit,then expand to 12bits according clip_lend.
28	R/W	0	Clip8_mode: active high if this bit set high ,viu_12bit422to10bit444_encp work clip8_mode ,output high 8bits value of din and clip data to 8bit,then expand to 12bits according clip_lend.
27	R/W	0	clip_lend :active high make output data to 12bits in clip10_mode/clip8_mode/scramble 1;expand bits in high bits 0: ;expand bits low bits
26	R/W	0	scramble_mode :active high

Bit(s)	R/W	Default	Description
			viu_12bit422to10bit444_encp module get luma and chroma from 422 format data every pixel ,then reorganize data to 8bits according to reg_tunnel value(this model can change data from 422 to 444??). Luma = din[35:24] Chroma =odd_pixel?din[23:12]:din[11:0]
25	R/W	0	go_field_en 1:rst odd_pixel to 0 when go_filed come
24	R/W	0	go_line_en 1:rst rst odd_pixel to 0 when go_line come
23	R/W	0	oft_rst_en 1:soft rst rst odd_pixel to 0
22	R/W	0	de_sel : input data de singal 1:chose encp require singal as de 0:close this module
17:15	R/W	0	reg_tunnel_sel_b1 : select high 4 bits for B from {luma,chroma} ,only work in scramble mode: 0:bit[3:0] 1:bit[7:3] 2:bit[11:8] 3:bit[15:12] 4:bit[19:16] 5:bit[23:20] Default:bit[23:20]
14:12	R/W	0	reg_tunnel_sel_g1 : select high 4 bits for G from {luma,chroma} ,only work in scramble mode: 0:bit[3:0] 1:bit[7:3] 2:bit[11:8] 3:bit[15:12] 4:bit[19:16] 5:bit[23:20] Default:bit[23:20]
11:9	R/W	0	reg_tunnel_sel_r1 : select high 4 bits for R from {luma,chroma} ,only work in scramble mode: 0:bit[3:0] 1:bit[7:3] 2:bit[11:8] 3:bit[15:12] 4:bit[19:16] 5:bit[23:20] Default:bit[23:20]
8:6	R/W	0	reg_tunnel_sel_B0 : select low 4 bits for B from {luma,chroma} ,only work in scramble mode: 0:bit[3:0] 1:bit[7:3] 2:bit[11:8] 3:bit[15:12] 4:bit[19:16] 5:bit[23:20] Default:bit[23:20]

Bit(s)	R/W	Default	Description
5:3	R/W	0	reg_tunnel_sel_g0 : select low 4 bits for G from {luma,chroma} ,only work in scramble mode: 0:bit[3:0] 1:bit[7:3] 2:bit[11:8] 3:bit[15:12] 4:bit[19:16] 5:bit[23:20] Default:bit[23:20]
2:0	R/W	0	reg_tunnel_sel_r0 : select low 4 bits for R from {luma,chroma} ,only work in scramble mode: 0:bit[3:0] 1:bit[7:3] 2:bit[11:8] 3:bit[15:12] 4:bit[19:16] 5:bit[23:20] Default:bit[23:20]

Same as VPU\_422TO444\_CTRL0, viu\_12bit422to10bit444\_vd1 VPU\_VIU2VDIN\_HDN\_CTRL 0x2780.

**Table 9-148 VPU\_422TO444\_CTRL1 0x274c**

Bit(s)	R/W	Default	Description
20	R/W	0	software reset
19-18	R/W	0	reg_viu2vdin_dn_ratio: down-scale ratio: 0->no scale; 1-> 1/2; 2->1/4; 3->reserved
17-16	R/W	0	reg_viu2vdinflt_mode: filter mode; 0->no filter; 1->[0 2 2 0]/4; 2->[1 1 1 1]/4; 3->[1 3 3 1]/8
15-14	R/W	0	reserved
13-0	R/W	0	reg_viu2vdin_hsize: source horizontal size

**Table 9-149 VPU\_VIU\_ASYNC\_MASK 0x2781**

Bit(s)	R/W	Default	Description
31:28	R/W	0	reserved
27:24	R/W	0	VDIN_STTs_data => VPP
23:20	R/W	0	Nr/di -> Idim
19-18	R/W	0	reg_viu2vdin_dn_ratio: down-scale ratio: 0->no scale; 1-> 1/2; 2->1/4; 3->reserved
11:8	R/W	0	Vpp afbc-> di pre inp
7:4	R/W	0	Mask vd1-> di post input
3:0	R/W	0	Mask di post => VPP_VD1_IN

Table 9-150 VDIN\_MISC\_CTRL 0x2782

Bit(s)	R/W	Default	Description
31:25	R/W	0	reserved
24:21	R/W	0	Vdin_arb_gclk_ctrl
20	R/W	0	Vdin0/vdin ctrl mux 0: vdin0,1:VDIN1
19:18	R/W	0	Vdin1_fix_disable
17:16	R/W	0	Vdin0_Fix_disable
15:5	R/W	0	reserved
4	R/W	0	Vdin1_wr_rst_n
3	R/W	0	Vdin0_wr_rst_n
2	R/W	0	Nrin_mux_wr_rst_n
1	R/W	0	Vdin1_rst_n
0	R/W	0	Vdin0_rst_n

Table 9-151 VPU\_VIU\_VDIN\_IF\_MUX\_CTRL 0x2783

Bit(s)	R/W	Default	Description
28-24	R/W	0	//Select VIU to "VDIN0/VDIN1 source 9" data path , must clear it first before changing the path sel //5'b00000= Disable VIU to VDIN path //5'b00001= Enble VIU of ENC_I domain to VDIN //5'b00010= Enble VIU of ENC_P domain to VDIN //5'b00100= Enble VIU of ENC_T domain to VDIN //5'b01000= Enble VIU WriteBack 1 domain to VDIN //5'b10000= Enble VIU WriteBack 2 domain to VDIN
20-16	R/W	0	//Select VIU Clock to "VDIN0/VDIN1 source 9" clk path , must clear it first before changing the path sel //5'b00000= Disable VIU to VDIN clock //5'b00001= Enble clock VIU of ENC_I domain to VDIN //5'b00010= Enble clock VIU of ENC_P domain to VDIN //5'b00100= Enble clock VIU of ENC_T domain to VDIN //5'b01000= Enble clock VIU WriteBack 1 domain to VDIN //5'b10000= Enble clock VIU WriteBack 2 domain to VDIN
12-8	R/W	0	//Select VIU to "VDIN0/VDIN1 source 7" data path , must clear it first before changing the path sel //5'b00000= Disable VIU to VDIN clock //5'b00001= Enble clock VIU of ENC_I domain to VDIN //5'b00010= Enble clock VIU of ENC_P domain to VDIN //5'b00100= Enble clock VIU of ENC_T domain to VDIN //5'b01000= Enble clock VIU WriteBack 1 domain to VDIN //5'b10000= Enble clock VIU WriteBack 2 domain to VDIN
4-0	R/W	0	//Select Clock to "VDIN0/VDIN1 source 7" , must clear it first before changing the path sel //5'b00000= Disable VIU to VDIN clock //5'b00001= Enble clock VIU of ENC_I domain to VDIN //5'b00010= Enble clock VIU of ENC_P domain to VDIN //5'b00100= Enble clock VIU of ENC_T domain to VDIN //5'b01000= Enble clock VIU WriteBack 1 domain to VDIN //5'b10000= Enble clock VIU WriteBack 2 domain to VDIN

Table 9-152 VPU\_VIU2VDIN1\_HDN\_CTRL 0x2784

Bit(s)	R/W	Default	Description
20	R/W	0	software reset
19-18	R/W	0	reg_viu2vdin2_dn_ratio: down-scale ratio: 0->no scale; 1-> 1/2; 2->1/4; 3->reserved
17-16	R/W	0	reg_viu2vdin2flt_mode: filter mode; 0->no filter; 1->[0 2 2 0]/4; 2->[1 1 1 1]/4; 3->[1 3 3 1]/8
15-14	R/W	0	reserved
13-0	R/W	0	reg_viu2vdin2_hsize: source horizontal size

Table 9-153 VPU\_VENCX\_CLK\_CTRL 0x2785

Bit(s)	R/W	Default	Description
2	R/W	0	Enci_afifo_clk: 0: cts_vpu_clk_tm 1: cts_vpu_clkc_tm
1	R/W	0	Encl_afifo_clk: 0: cts_vpu_clk_tm 1: cts_vpu_clkc_tm
0	R/W	0	Encp_afifo_clk: 0: cts_vpu_clk_tm 1: cts_vpu_clkc_tm

Table 9-154 VPU\_RDARB\_MODE\_L1C1 0x2790

Bit(s)	R/W	Default	Description
21:16	R/W	0	rdarb_sel : uns, default = 0 , rdarb_sel [0]==0 slave dc0 connect master port0 rdarb_sel[0]==1 slave dc0 connect master port1 rdarb_sel [1]==0 slave dc1 connect master port0 rdarb_sel[1]==1 slave dc1 connect master port1 rdarb_sel [2]==0 slave dc2 connect master port0 rdarb_sel[2]==1 slave dc2 connect master port1 rdarb_sel [3]==0 slave dc3 connect master port0 rdarb_sel [3]==1 slave dc3 connect master port1 rdarb_sel [4]==0 slave dc4 connect master port0 rdarb_sel[4]==1 slave dc4 connect master port1 rdarb_sel [5]==0 slave dc5 connect master port0 rdarb_sel[5]==1 slave dc5 connect master port1
9:8	R/W	0	rdarb_arb_mode : uns, default = 0 , rdarb_arb_mode [0] master port0 arb way, rdarb_arb_mode [1] master port1 arb way,
3:0	R/W	0	rdarb_gate_clk_ctrl : uns, default = 0 , rdarb_gate_clk_ctrl [1:0] master port0 clk gate control rdarb_gate_clk_ctrl [3:2] master port1 clk gate control

Table 9-155 VPU\_RDARB\_REQEN\_SLV\_L1C1 0x2791

Bit(s)	R/W	Default	Description
11:0	R/W	0xfff	rdarb_dc_req_en : unsigned , default = 12'hfff rdarb_dc_req_en [0]: the slv0 req to mst port0 enable, rdarb_dc_req_en [1]: the slv1 req to mst port0 enable, rdarb_dc_req_en [2]: the slv2 req to mst port0 enable, rdarb_dc_req_en [3]: the slv3 req to mst port0 enable, rdarb_dc_req_en [4]: the slv4 req to mst port0 enable, rdarb_dc_req_en [5]: the slv5 req to mst port0 enable, rdarb_dc_req_en [6]: the slv0 req to mst port1 enable, rdarb_dc_req_en [7]: the slv1 req to mst port1 enable, rdarb_dc_req_en [8]: the slv2 req to mst port1 enable, rdarb_dc_req_en [9]: the slv3 req to mst port1 enable, rdarb_dc_req_en [10]: the slv4 req to mst port1 enable, rdarb_dc_req_en [11]: the slv5 req to mst port1 enable,



Table 9-156 VPU\_RDARB\_WEIGHT0\_SLV\_L1C1 0x2792

Bit(s)	R/W	Default	Description
29:0	R/W	0	rddc_weigh_sxn : unsigned , default = 0 rddc_weigh_sxn [0*6+6]: the slv0 req weigh number rddc_weigh_sxn [1*6+6]: the slv1 req weigh number rddc_weigh_sxn [2*6+6]: the slv2 req weigh number rddc_weigh_sxn [3*6+6]: the slv3 req weigh number rddc_weigh_sxn [4*6+6]: the slv4 req weigh number

Table 9-157 VPU\_RDARB\_WEIGHT1\_SLV\_L1C1 0x2793

Bit(s)	R/W	Default	Description
5:0	R/W	0	rddc_weigh_sxn : unsigned , default = 0 rddc_weigh_sxn [5*6+6]: the slv5 req weigh number

Table 9-158 VPU\_WRARB\_MODE\_L1C1 0x2794

Bit(s)	R/W	Default	Description
21:16	R/W	0	wrarb_sel : uns, default = 0 , wrarb_sel [0]==0 slave dc0 connect master port0 wrarb_sel[0]==1 slave dc0 connect master port1 wrarb_sel [1]==0 slave dc1 connect master port0 wrarb_sel[1]==1 slave dc1 connect master port1 wrarb_sel [2]==0 slave dc2 connect master port0 wrarb_sel[2]==1 slave dc2 connect master port1 wrarb_sel [3]==0 slave dc3 connect master port0 wrarb_sel[3]==1 slave dc3 connect master port1 wrarb_sel [4]==0 slave dc4 connect master port0 wrarb_sel[4]==1 slave dc4 connect master port1 wrarb_sel [5]==0 slave dc5 connect master port0 wrarb_sel[5]==1 slave dc5 connect master port1
9:8	R/W	0	wrarb_arb_mode : uns, default = 0 , wrarb_arb_mode [0] master port0 arb way, wrarb_arb_mode [1] master port1 arb way,
3:0	R/W	0	wrarb_gate_clk_ctrl : uns, default = 0 , wrarb_gate_clk_ctrl [1:0] master port0 clk gate control wrarb_gate_clk_ctrl [3:2] master port1 clk gate control

Table 9-159 VPU\_WRARB\_REQEN\_SLV\_L1C1 0x2795

Bit(s)	R/W	Default	Description
11:0	R/W	0	wrarb_dc_req_en : unsigned , default = 0 wrarb_dc_req_en [0]: the slv0 req to mst port0 enable, wrarb_dc_req_en [1]: the slv1 req to mst port0 enable, wrarb_dc_req_en [2]: the slv2 req to mst port0 enable, wrarb_dc_req_en [3]: the slv3 req to mst port0 enable, wrarb_dc_req_en [4]: the slv4 req to mst port0 enable, wrarb_dc_req_en [5]: the slv5 req to mst port0 enable, wrarb_dc_req_en [0]: the slv0 req to mst port1 enable, wrarb_dc_req_en [1]: the slv1 req to mst port1 enable, wrarb_dc_req_en [2]: the slv2 req to mst port1 enable, wrarb_dc_req_en [3]: the slv3 req to mst port1 enable, wrarb_dc_req_en [4]: the slv4 req to mst port1 enable, wrarb_dc_req_en [5]: the slv5 req to mst port1 enable,

Table 9-160 VPU\_WRARB\_WEIGHT0\_SLV\_L1C1 0x2796

Bit(s)	R/W	Default	Description
29:0	R/W	0	wrdc_weigh_sxn : unsigned , default = 0 wrdc_weigh_sxn [0*6+:6]: the slv0 req weigh number wrdc_weigh_sxn [1*6+:6]: the slv1 req weigh number wrdc_weigh_sxn [2*6+:6]: the slv2 req weigh number wrdc_weigh_sxn [3*6+:6]: the slv3 req weigh number wrdc_weigh_sxn [4*6+:6]: the slv4 req weigh number

Table 9-161 VPU\_WRARB\_WEIGHT1\_SLV\_L1C1 0x2797

Bit(s)	R/W	Default	Description
5:0	R/W	0	wrdc_weigh_sxn : unsigned , default = 0 wrdc_weigh_sxn [5*6+:6]: the slv5 req weigh number

Table 9-162 VPU\_RDWR\_ARB\_STATUS\_L1C1 0x2798

Bit(s)	R/W	Default	Description
3:2	R/W	0	wrarb_arb_busy : unsigned , default = 0
1:0	R/W	0	rdarb_arb_busy : unsigned , default = 0

Table 9-163 VPU\_RDARB\_MODE\_L1C2 0x2799

Bit(s)	R/W	Default	Description
20:16	R/W	0	rdarb_sel : uns, default = 0 , rdarb_sel [0]==0 slave dc0 connect master port0 rdarb_sel[0]==1 slave dc0 connect master port1 rdarb_sel [1]==0 slave dc1 connect master port0 rdarb_sel[1]==1 slave dc1 connect master port1 rdarb_sel [2]==0 slave dc2 connect master port0 rdarb_sel[2]==1 slave dc2 connect master port1 rdarb_sel [3]==0 slave dc3 connect master port0 rdarb_sel[3]==1 slave dc3 connect master port1 rdarb_sel [4]==0 slave dc4 connect master port0 rdarb_sel[4]==1 slave dc4 connect master port1
9:8	R/W	0	rdarb_arb_mode : uns, default = 0 , rdarb_arb_mode [0] master port0 arb way, rdarb_arb_mode [1] master port1 arb way,
3:0	R/W	0	rdarb_gate_clk_ctrl : uns, default = 0 , rdarb_gate_clk_ctrl [1:0] master port0 clk gate control rdarb_gate_clk_ctrl [3:2] master port0 clk gate control

Table 9-164 VPU\_RDARB\_REQEN\_SLV\_L1C2 0x279a

Bit(s)	R/W	Default	Description
9:0	R/W	0	rdarb_dc_req_en : unsigned , default = 0 rdarb_dc_req_en [0]: the slv0 req to mst port0 enable, rdarb_dc_req_en [1]: the slv1 req to mst port0 enable, rdarb_dc_req_en [2]: the slv2 req to mst port0 enable, rdarb_dc_req_en [3]: the slv3 req to mst port0 enable, rdarb_dc_req_en [4]: the slv4 req to mst port0 enable, rdarb_dc_req_en [5]: the slv0 req to mst port1 enable, rdarb_dc_req_en [6]: the slv1 req to mst port1 enable, rdarb_dc_req_en [7]: the slv2 req to mst port1 enable, rdarb_dc_req_en [8]: the slv3 req to mst port1 enable, rdarb_dc_req_en [9]: the slv4 req to mst port1 enable,

Table 9-165 VPU\_RDARB\_WEIGHT0\_SLV\_L1C2 0x279b

Bit(s)	R/W	Default	Description
29:0	R/W	0	rddc_weigh_sxn : unsigned , default = 0 rddc_weigh_sxn [0*6+6]: the slv0 req weigh number rddc_weigh_sxn [1*6+6]: the slv1 req weigh number rddc_weigh_sxn [2*6+6]: the slv2 req weigh number rddc_weigh_sxn [3*6+6]: the slv3 req weigh number rddc_weigh_sxn [4*6+6]: the slv4 req weigh number

Table 9-166 VPU\_RDWR\_ARB\_STATUS\_L1C2 0x279c

Bit(s)	R/W	Default	Description
1:0	R/W	0	rdarb_arb_busy : unsigned , default = 0

Table 9-167 VPU\_RDARB\_MODE\_L2C1 0x279d

Bit(s)	R/W	Default	Description
27:16	R/W	0	rdarb_sel : uns, default = 0 , rdarb_sel [0]==0 slave dc0 connect master port0 rdarb_sel[0]==1 slave dc0 connect master port1 rdarb_sel [1]==0 slave dc1 connect master port0 rdarb_sel[1]==1 slave dc1 connect master port1 rdarb_sel [2]==0 slave dc2 connect master port0 rdarb_sel[2]==1 slave dc2 connect master port1 rdarb_sel [3]==0 slave dc3 connect master port0 rdarb_sel[3]==1 slave dc3 connect master port1 rdarb_sel [4]==0 slave dc4 connect master port0 rdarb_sel[4]==1 slave dc4 connect master port1 rdarb_sel [5]==0 slave dc5 connect master port0 rdarb_sel[5]==1 slave dc5 connect master port1
10:8	R/W	0	rdarb_arb_mode : uns, default = 0 , rdarb_arb_mode [0] master port0 arb way, rdarb_arb_mode [1] master port1 arb way,
5:0	R/W	0	rdarb_gate_clk_ctrl : uns, default = 0 , rdarb_gate_clk_ctrl [1:0] master port0 clk gate control rdarb_gate_clk_ctrl [3:2] master port1 clk gate control rdarb_gate_clk_ctrl [5:4] master port2 clk gate control

Table 9-168 VPU\_RDARB\_REQEN\_SLV\_L2C1 0x279e

Bit(s)	R/W	Default	Description
17:0	R/W	0	rdarb_dc_req_en : unsigned , default = 0 rdarb_dc_req_en [0]: the slv0 req to mst port0 enable, rdarb_dc_req_en [1]: the slv1 req to mst port0 enable, rdarb_dc_req_en [2]: the slv2 req to mst port0 enable, rdarb_dc_req_en [3]: the slv3 req to mst port0 enable, rdarb_dc_req_en [4]: the slv4 req to mst port0 enable, rdarb_dc_req_en [5]: the slv5 req to mst port0 enable, rdarb_dc_req_en [0]: the slv0 req to mst port1 enable, rdarb_dc_req_en [1]: the slv1 req to mst port1 enable, rdarb_dc_req_en [2]: the slv2 req to mst port1 enable, rdarb_dc_req_en [3]: the slv3 req to mst port1 enable, rdarb_dc_req_en [4]: the slv4 req to mst port1 enable, rdarb_dc_req_en [5]: the slv5 req to mst port1 enable,

Table 9-169 VPU\_RDARB\_WEIGHT0\_SLV\_L2C1 0x279f

Bit(s)	R/W	Default	Description
29:0	R/W	0	rddc_weigh_sxn : unsigned , default = 0 rddc_weigh_sxn [0*6+:6]: the slv0 req weigh number rddc_weigh_sxn [1*6+:6]: the slv1 req weigh number rddc_weigh_sxn [2*6+:6]: the slv2 req weigh number rddc_weigh_sxn [3*6+:6]: the slv3 req weigh number rddc_weigh_sxn [4*6+:6]: the slv4 req weigh number

Table 9-170 VPU\_RDARB\_WEIGHT1\_SLV\_L2C1 0x27a0

Bit(s)	R/W	Default	Description
5:0	R/W	0	rddc_weigh_sxn : unsigned , default = 0 rddc_weigh_sxn [5*6+:6]: the slv5 req weigh number

Table 9-171 VPU\_RDWR\_ARB\_STATUS\_L2C1 0x27a1

Bit(s)	R/W	Default	Description
3:2	R/W	0	wrarb_arb_busy : unsigned , default = 0
1:0	R/W	0	rdarb_arb_busy : unsigned , default = 0

Table 9-172 VPU\_WRARB\_MODE\_L2C1 0x27a2

Bit(s)	R/W	Default	Description
19:16	R/W	0	wrarb_sel : uns, default = 0 , wrarb_sel [0]==0 slave dc0 connect master port0 wrarb_sel[0]==1 slave dc0 connect master port1 wrarb_sel [1]==0 slave dc1 connect master port0 wrarb_sel[1]==1 slave dc1 connect master port1 wrarb_sel [2]==0 slave dc2 connect master port0 wrarb_sel[2]==1 slave dc2 connect master port1 wrarb_sel [3]==0 slave dc3 connect master port0 wrarb_sel[3]==1 slave dc3 connect master port1
9:8	R/W	0	wrarb_arb_mode : uns, default = 0 , wrarb_arb_mode [0] master port0 arb way, wrarb_arb_mode [1] master port1 arb way,
3:0	R/W	0	wrarb_gate_clk_ctrl : uns, default = 0 , wrarb_gate_clk_ctrl [1:0] master port0 clk gate control wrarb_gate_clk_ctrl [3:2] master port0 clk gate control

Table 9-173 VPU\_WRARB\_REQEN\_SLV\_L2C1 0x27a3

Bit(s)	R/W	Default	Description
7:0	R/W	0	wrarb_dc_req_en : unsigned , default = 0 wrarb_dc_req_en [0]: the slv0 req to mst port0 enable, wrarb_dc_req_en [1]: the slv1 req to mst port0 enable, wrarb_dc_req_en [2]: the slv2 req to mst port0 enable, wrarb_dc_req_en [3]: the slv3 req to mst port0 enable, wrarb_dc_req_en [0]: the slv0 req to mst port1 enable, wrarb_dc_req_en [1]: the slv1 req to mst port1 enable, wrarb_dc_req_en [2]: the slv2 req to mst port1 enable, wrarb_dc_req_en [3]: the slv3 req to mst port1 enable,

Table 9-174 VPU\_WRARB\_WEIGHT0\_SLV\_L2C1 0x27a4

Bit(s)	R/W	Default	Description
23:0	R/W	0	wrdc_weigh_sxn : unsigned , default = 0 wrdc_weigh_sxn [0*6+:6]: the slv0 req weigh number wrdc_weigh_sxn [1*6+:6]: the slv1 req weigh number wrdc_weigh_sxn [2*6+:6]: the slv2 req weigh number wrdc_weigh_sxn [3*6+:6]: the slv3 req weigh number

Table 9-175 VPU\_ASYNC\_RD\_MODE0 0x27a5

Bit(s)	R/W	Default	Description
18	R/W	0	req_en : unsigned , default = 0 async enable
17:16	R/W	0	clk_gate_ctrl : unsigned , default = 0 async clock gate control
15:12	R/W	4	auto_arugt_weight : unsigned , default = 4
10:9	R/W	0	arugt_sel : unsigned , default = 0 00 : use auto fifo arugt generate the output arugt. 01 : use the register bit control 00 : use the input argument
8	R/W	0	arguent_cfg : unsigned , default = 0 register arguent control bit
7:4	R/W	4	rd_hold_num : unsigned , default = 4 hold the read command threshold
3:0	R/W	0	rd_rel_num : unsigned , default = 0 release the read command threshold

Table 9-176 VPU\_ASYNC\_RD\_MODE1 0x27a6

Bit(s)	R/W	Default	Description
18	R/W	0	req_en : unsigned , default = 0 async enable
17:16	R/W	0	clk_gate_ctrl : unsigned , default = 0 async clock gate control
15:12	R/W	4	auto_arugt_weight : unsigned , default = 4
10:9	R/W	0	arugt_sel : unsigned , default = 0 00 : use auto fifo arugt generate the output arugt. 01 : use the register bit control 00 : use the input argument
8	R/W	0	arguent_cfg : unsigned , default = 0 register arguent control bit
7:4	R/W	4	rd_hold_num : unsigned , default = 4 hold the read command threshold
3:0	R/W	0	rd_rel_num : unsigned , default = 0 release the read command threshold

Table 9-177 VPU\_ASYNC\_RD\_MODE2 0x27a7

Bit(s)	R/W	Default	Description
18	R/W	0	req_en : unsigned , default = 0 async enable
17:16	R/W	0	clk_gate_ctrl : unsigned , default = 0 async clock gate control
15:12	R/W	4	auto_arugt_weight : unsigned , default = 4
10:9	R/W	0	arugt_sel : unsigned , default = 0 00 : use auto fifo arugt generate the output arugt. 01 : use the register bit control 00 : use the input argument
8	R/W	0	arguent_cfg : unsigned , default = 0 register arguent control bit
7:4	R/W	4	rd_hold_num : unsigned , default = 4 hold the read command threshold
3:0	R/W	0	rd_rel_num : unsigned , default = 0 release the read command threshold

Table 9-178 VPU\_ASYNC\_RD\_MODE3 0x27a8

Bit(s)	R/W	Default	Description
18	R/W	0	req_en : unsigned , default = 0 async enable
17:16	R/W	0	clk_gate_ctrl : unsigned , default = 0 async clock gate control
15:12	R/W	4	auto_arugt_weight : unsigned , default = 4
10:9	R/W	0	arugt_sel : unsigned , default = 0 00 : use auto fifo arugt generate the output arugt. 01 : use the register bit control 00 : use the input arguent
8	R/W	0	arguent_cfg : unsigned , default = 0 register arguent control bit
7:4	R/W	4	rd_hold_num : unsigned , default = 4 hold the read command threshold
3:0	R/W	0	rd_rel_num : unsigned , default = 0 release the read command threshold

Table 9-179 VPU\_ASYNC\_RD\_MODE4 0x27a9

Bit(s)	R/W	Default	Description
18	R/W	0	req_en : unsigned , default = 0 async enable
17:16	R/W	0	clk_gate_ctrl : unsigned , default = 0 async clock gate control
15:12	R/W	4	auto_arugt_weight : unsigned , default = 4
10:9	R/W	0	arugt_sel : unsigned , default = 0 00 : use auto fifo arugt generate the output arugt. 01 : use the register bit control 00 : use the input arguent
8	R/W	0	arguent_cfg : unsigned , default = 0 register arguent control bit
7:4	R/W	4	rd_hold_num : unsigned , default = 4 hold the read command threshold
3:0	R/W	0	rd_rel_num : unsigned , default = 0 release the read command threshold

Table 9-180 VPU\_ASYNC\_WR\_MODE0 0x27aa

Bit(s)	R/W	Default	Description
18	R/W	0	req_en : unsigned , default = 0 async enable
17:16	R/W	0	clk_gate_ctrl : unsigned , default = 0 async clock gate control
15:12	R/W	4	auto_arugt_weight : unsigned , default = 4
10:9	R/W	0	arugt_sel : unsigned , default = 0 00 : use auto fifo arugt generate the output arugt. 01 : use the register bit control 00 : use the input arguent
8	R/W	0	arguent_cfg : unsigned , default = 0 register arguent control bit
7:4	R/W	4	wr_hold_num : unsigned , default = 4 hold the read command threshold
3:0	R/W	0	wr_rel_num : unsigned , default = 0 release the write command threshold

**Table 9-181 VPU\_ASYNC\_WR\_MODE1 0x27ab**

Bit(s)	R/W	Default	Description
18	R/W	0	req_en : unsigned , default = 0 async enable
17:16	R/W	0	clk_gate_ctrl : unsigned , default = 0 async clock gate control
15:12	R/W	4	auto_arugt_weight : unsigned , default = 4
10:9	R/W	0	arugt_sel : unsigned , default = 0 00 : use auto fifo arugt generate the output arugt. 01 : use the register bit control 00 : use the input arguent
8	R/W	0	arguent_cfg : unsigned , default = 0 register arguent control bit
7:4	R/W	4	wr_hold_num : unsigned , default = 4 hold the read command threshold
3:0	R/W	0	wr_rel_num : unsigned , default = 0 release the write command threshold

**Table 9-182 VPU\_ASYNC\_WR\_MODE2 0x27ac**

Bit(s)	R/W	Default	Description
18	R/W	0	req_en : unsigned , default = 0 async enable
17:16	R/W	0	clk_gate_ctrl : unsigned , default = 0 async clock gate control
15:12	R/W	4	auto_arugt_weight : unsigned , default = 4
10:9	R/W	0	arugt_sel : unsigned , default = 0 00 : use auto fifo arugt generate the output arugt. 01 : use the register bit control 00 : use the input arguent
8	R/W	0	arguent_cfg : unsigned , default = 0 register arguent control bit
7:4	R/W	4	wr_hold_num : unsigned , default = 4 hold the read command threshold
3:0	R/W	0	wr_rel_num : unsigned , default = 0 release the write command threshold

**Table 9-183 VPU\_ASYNC\_STAT 0x27ad**

Bit(s)	R/W	Default	Description
18	R/W	0x0	axiwr2_chan_idle : unsigned , RO, axi write channel2 idle state
17	R/W	0x0	axiwr1_chan_idle : unsigned , RO, axi write channel1 idle state
16	R/W	0x0	axiwr0_chan_idle : unsigned , RO, axi write channel0 idle state
4	R/W	0x0	axird4_chan_idle : unsigned , RO, axi read channel4 idle state
3	R/W	0x0	axird3_chan_idle : unsigned , RO, axi read channel3 idle state
2	R/W	0x0	axird2_chan_idle : unsigned , RO, axi read channel2 idle state
1	R/W	0x0	axird1_chan_idle : unsigned , RO, axi read channel1 idle state
0	R/W	0x0	axird0_chan_idle : unsigned , RO, axi read channel0 idle state

**Table 9-184 VPU\_HDMI\_DITH\_01\_04 0x27f0**

Bit(s)	R/W	Default	Description
31-0	R/W	0x8214_1428	dith lut VPU_HDMI_DITH_CNTL[0] : 1 : lut for 10b to 8b 0 : lut for 12b to 10b

**Table 9-185 VPU\_HDMI\_DITH\_01\_15 0x27f1**

Bit(s)	R/W	Default	Description
31-0	R/W	0x4128_ 2841	dith lut VPU_HDMI_DITH_CNTL[0] : 1 : lut for 10b to 8b 0 : lut for 12b to 10b

**Table 9-186 VPU\_HDMI\_DITH\_01\_26 0x27f2**

Bit(s)	R/W	Default	Description
31-0	R/W	0x2841_ 4182	dith lut VPU_HDMI_DITH_CNTL[0] : 1 : lut for 10b to 8b 0 : lut for 12b to 10b

**Table 9-187 VPU\_HDMI\_DITH\_01\_37 0x27f3**

Bit(s)	R/W	Default	Description
31-0	R/W	0x1482_ 8214	dith lut VPU_HDMI_DITH_CNTL[0] : 1 : lut for 10b to 8b 0 : lut for 12b to 10b

**Table 9-188 VPU\_HDMI\_DITH\_10\_04 0x27f4**

Bit(s)	R/W	Default	Description
31-0	R/W	0x9669_ 9696	dith lut VPU_HDMI_DITH_CNTL[0] : 1 : lut for 10b to 8b 0 : lut for 12b to 10b

**Table 9-189 VPU\_HDMI\_DITH\_10\_15 0x27f5**

Bit(s)	R/W	Default	Description
31-0	R/W	0x3c3c_ 6969	dith lut VPU_HDMI_DITH_CNTL[0] : 1 : lut for 10b to 8b 0 : lut for 12b to 10b

**Table 9-190 VPU\_HDMI\_DITH\_10\_26 0x27f6**

Bit(s)	R/W	Default	Description
31-0	R/W	0x6996_ 9696	dith lut VPU_HDMI_DITH_CNTL[0] : 1 : lut for 10b to 8b 0 : lut for 12b to 10b

**Table 9-191 VPU\_HDMI\_DITH\_10\_37 0x27f7**

Bit(s)	R/W	Default	Description
31-0	R/W	0xc3c3_ 6969	dith lut VPU_HDMI_DITH_CNTL[0] : 1 : lut for 10b to 8b 0 : lut for 12b to 10b



**Table 9-192 VPU\_HDMI\_DITH\_11\_04 0x27f8**

Bit(s)	R/W	Default	Description
31-0	R/W	0x7deb_ ebd7	dith lut VPU_HDMI_DITH_CNTL[0] : 1 : lut for 10b to 8b 0 : lut for 12b to 10b

**Table 9-193 VPU\_HDMI\_DITH\_11\_15 0x27f9**

Bit(s)	R/W	Default	Description
31-0	R/W	0xbed7_ d7be	dith lut VPU_HDMI_DITH_CNTL[0] : 1 : lut for 10b to 8b 0 : lut for 12b to 10b

**Table 9-194 VPU\_HDMI\_DITH\_11\_26 0x27fa**

Bit(s)	R/W	Default	Description
31-0	R/W	0xd7be_ be7d	dith lut VPU_HDMI_DITH_CNTL[0] : 1 : lut for 10b to 8b 0 : lut for 12b to 10b

**Table 9-195 VPU\_HDMI\_DITH\_11\_37 0x27fb**

Bit(s)	R/W	Default	Description
31-0	R/W	0xeb7d_ 7deb	dith lut VPU_HDMI_DITH_CNTL[0] : 1 : lut for 10b to 8b 0 : lut for 12b to 10b

10b to 8b dither control register. 12b to 10b see VPU\_HDMI\_FMT\_CTRL

**Table 9-196 VPU\_HDMI\_DITH\_CNTL 0x27fc**

Bit(s)	R/W	Default	Description
21-19	R/W	0	frame count offset for B
18-16	R/W	0	frame count offset for G
15	R/W	0	hcnt hold when de valid
14	R/W	0	RGB frame count seperate
13	R/W	0	dith4x4 : frame random enable
12	R/W	0	dith4x4 enable
11	R/W	0	tunnel enable for DOLBY
10	R/W	0	rounding enable
9-6	R/W	0	Cntl_hdmi_dith10 :
5	R/W	0	Cntl_hdmi_dith_md:
4	R/W	0	Cntl_hdmi_dith_en: dither 10-b to 8-b enable
3	R/W	0	hsync invert
2	R/W	0	vsync invert
0	R/W	0	dither lut sel : 1 : sel 10b to 8b 0: sel 12b to 10b

**Table 9-197 VPU\_VENCL\_DITH\_CTRL 0x27e0**

Bit(s)	R/W	Default	Description
19-17	R/W	0	dither 2x2 : frame number sel
16	R/W	0	dither 2x2 : frame number random
15-14	R/W	0	Reserved
13-11	R/W	7	G frame number offset
10-8	R/W	3	B frame number offset
7	R/W	0	Reserved
6	R/W	1	dither 4x4 : G/B frame number = B frame number + offset g/b
5	R/W	0	dither 4x4 : frame number random
4	R/W	1	dither 4x4 : enable
3	R/W	0	Reserved
2	R/W	0	dither md
1	R/W	0	rounding enable
0	R/W	1	dither enable

**Table 9-198 VPU\_VENCL\_DITH\_LUT\_1 0x27e1**

Bit(s)	R/W	Default	Description
31-0	R/W	0x8214_ 1428	dith lut

**Table 9-199 VPU\_VENCL\_DITH\_LUT\_2 0x27e2**

Bit(s)	R/W	Default	Description
31-0	R/W	0x4128_ 2841	dith lut

**Table 9-200 VPU\_VENCL\_DITH\_LUT\_3 0x27e3**

Bit(s)	R/W	Default	Description
31-0	R/W	0x2841_ 4182	dith lut

**Table 9-201 VPU\_VENCL\_DITH\_LUT\_4 0x27e4**

Bit(s)	R/W	Default	Description
31-0	R/W	0x1482_ 8214	dith lut

**Table 9-202 VPU\_VENCL\_DITH\_LUT\_5 0x27e5**

Bit(s)	R/W	Default	Description
31-0	R/W	0x9669_ 9696	dith lut

**Table 9-203 VPU\_VENCL\_DITH\_LUT\_6 0x27e6**

Bit(s)	R/W	Default	Description
31-0	R/W	0x3c3c_6969	dith lut

**Table 9-204 VPU\_VENCL\_DITH\_LUT\_7 0x27e7**

Bit(s)	R/W	Default	Description
31-0	R/W	0x6996_9696	dith lut

**Table 9-205 VPU\_VENCL\_DITH\_LUT\_8 0x27e8**

Bit(s)	R/W	Default	Description
31-0	R/W	0xc3c3_6969	dith lut

**Table 9-206 VPU\_VENCL\_DITH\_LUT\_9 0x27e9**

Bit(s)	R/W	Default	Description
31-0	R/W	0x7deb_ebd7	dith lut

**Table 9-207 VPU\_VENCL\_DITH\_LUT\_10 0x27ea**

Bit(s)	R/W	Default	Description
31-0	R/W	0xbed7_d7be	dith lut

**Table 9-208 VPU\_VENCL\_DITH\_LUT\_11 0x27eb**

Bit(s)	R/W	Default	Description
31-0	R/W	0xd7be_be7d	dith lut

**Table 9-209 VPU\_VENCL\_DITH\_LUT\_12 0x27ec**

Bit(s)	R/W	Default	Description
31-0	R/W	0xeb7d_7deb	dith lut

### 9.2.3.2 VPU Video Lock Registers

**Table 9-210 VPU\_VLOCK\_CTRL 0x3000**

Bit(s)	R/W	Default	Description
31	R/W	0x0	Vid_lock_en: 1: enable video lock module
30	R/W	0x0	Reg_adj_enc: enable video lock to adjust encoder
29	R/W	0x0	Adj_pll: enable video lock to adjust PLL
28	R/W	0x0	Mpeg_vs: set this to 1, then 0, this is software controlled mpeg vsync
27-26	R/W	0x0	Output goes to which module: 0: encl, 1: encp, 2:enci
25-20	R/W	0x0	Output vsync width extend: make sure the vsync width is extended big enough for vpu_vid_lock_clk to sample
19	R/W	0x0	m frac right shift 1 : right shift 2 bit 0 : no shift
18-16	R/W	0x0	Input Vsync source select: 0: unuse, 1: fromhdmi rx , 2:from tv-decoder, 3: from dvin, 4: from dvin, 5: from 2nd bt656
15			Output vsync invert: 1, invert
14			Input vsync invert: 1, invert
13-8	R/W		Input vsync width extend: make sure the vsync width is extended big enough for vpu_vid_lock_clk to sample
7			Force loop1 err enable: 1. Force error of loop1
6			Force loop0 err enable: 1. Force error of loop0
5			Overwrite accum0 enable
4			Loop0 adjust capture enable
3			Loop0 adjust pll enable
2			Overwrite accum1 enable
1			Loop1 adjust capture enable
0			Loop0 adjust pll enable

**Table 9-211 VPU\_VLOCK\_MISC\_CTRL 0x3001**

Bit(s)	R/W	Default	Description
26-24	R/W	0x0	Adj_capt_pxgroups, make sure the pixel number in one line of encoder is multiples of 2^pxgroups
23-16	R/W	0x0	lfrm_cnt_mod: (output vsync freq)/(input vsync_freq * ifrm_cnt_mod) must be integer
15-8	R/W	0x0	Output vsync frequency
7-0	R/W	0x0	Input vsync frequency

**Table 9-212 VPU\_VLOCK\_LOOP0\_ACCUM\_LMT 0x3002**

Bit(s)	R/W	Default	Description
26-0	R/W	0x0	LOOP0 accumulator limit

**Table 9-213 VPU\_VLOCK\_LOOP0\_CTRL0 0x3003**

Bit(s)	R/W	Default	Description
31-24	R/W	0x0	Loop0 errclip rate
23-20	R/W	0x0	Loop0_adj_pll_rs, right shift of loop0 adjust pll portion
19-12	R/W	0x0	Loop0_adj_pll_gain, u1.7
11-8	R/W	0x0	Loop0_adj_capt_rs, right shift of loop0 adjust capture portion
7-0	R/W	0x0	Loop0_adj_capt_gain

**Table 9-214 VPU\_VLOCK\_LOOP0\_CTRL1 0x3004**

Bit(s)	R/W	Default	Description
23-20	R/W	0x0	Loop1_adj_pll_rs
19-12	R/W	0x0	Loop1_adj_pll_gain
11-8	R/W	0x0	Loop1_adj_capt_rs
7-0	R/W	0x0	Loop1_adj_capt_gain

**Table 9-215 VPU\_VLOCK\_LOOP1\_IMISSYNC\_MAX 0x3005**

Bit(s)	R/W	Default	Description
27-0	R/W	0x0	Loop1 imissync max, input signal is missed after input vsync counter is larger than this max threshold

**Table 9-216 VPU\_VLOCK\_LOOP1\_IMISSYNC\_MIN 0x3006**

Bit(s)	R/W	Default	Description
27-0	R/W	0x0	Loop1 imissync min, input signal is missed after input vsync counter is less than this max threshold

**Table 9-217 VPU\_VLOCK\_OVERWRITE\_ACCUM0 0x3007**

Bit(s)	R/W	Default	Description
27-0	R/W	0x0	Overwrite value of accum0

**Table 9-218 VPU\_VLOCK\_OVERWRITE\_ACCUM1 0x3008**

Bit(s)	R/W	Default	Description
27-0	R/W	0x0	Overwrite value of accum1

**Table 9-219 VPU\_VLOCK\_OUTPUT0\_CAPT\_LMT 0x3009**

Bit(s)	R/W	Default	Description
26-0	R/W	0x0	Output0 capture limit

**Table 9-220 VPU\_VLOCK\_OUTPUT0\_PLL\_LMT 0x300a**

Bit(s)	R/W	Default	Description
26-0	R/W	0x0	Output0 pll limit

**Table 9-221 VPU\_VLOCK\_OUTPUT1\_CAPT\_LMT 0x300b**

Bit(s)	R/W	Default	Description
26-0	R/W	0x0	Output1 capture limit

**Table 9-222 VPU\_VLOCK\_OUTPUT1\_PLL\_LMT 0x300c**

Bit(s)	R/W	Default	Description
26-0	R/W	0x0	Output1 pll limit

**Table 9-223 VPU\_VLOCK\_LOOP1\_PHSDIF\_TARGET 0x300d**

Bit(s)	R/W	Default	Description
27-0	R/W	0x0	Loop1 phase difference target, (input vsync - output vsync) phase distance target

**Table 9-224 VPU\_VLOCK\_RO\_LOOP0\_ACCUM 0x300e**

Bit(s)	R/W	Default	Description
27-0	R	0x0	Read only, loop0 accum result

**Table 9-225 VPU\_VLOCK\_RO\_LOOP1\_ACCUM 0x300f**

Bit(s)	R/W	Default	Description
27-0	R	0x0	Read only, loop1 accum result

**Table 9-226 VPU\_VLOCK\_OROW\_OCOL\_MAX 0x3010**

Bit(s)	R/W	Default	Description
29-16	R/W	0x0	Ocol_max
13-0	R/W	0x0	Orow_max

**Table 9-227 VPU\_VLOCK\_RO\_VS\_I\_D 0x3011**

Bit(s)	R/W	Default	Description
27-0	R	0x0	Read only, input vsync counter

**Table 9-228 VPU\_VLOCK\_RO\_VS\_O\_D 0x3012**

Bit(s)	R/W	Default	Description
27-0	R	0x0	Read only, output vsync counter

**Table 9-229 VPU\_VLOCK\_RO\_LINE\_PIX\_ADJ 0x3013**

Bit(s)	R/W	Default	Description
29-16	R	0x0	Read only, encoder line adjust number
13-0	R	0x0	Read only, encoder pix adjust number

**Table 9-230 VPU\_VLOCK\_RO\_OUTPUT\_00\_01 0x3014**

Bit(s)	R/W	Default	Description
31-16	R	0x0	Read only, accum0 output 00
15-0	R	0x0	Read only, accum0 output 01

**Table 9-231 VPU\_VLOCK\_RO\_OUTPUT\_10\_11 0x3015**

Bit(s)	R/W	Default	Description
31-16	R	0x0	Read only, accum1 output 10
15-0	R	0x0	Read only, accum1 output 11

**Table 9-232 VPU\_VLOCK\_MX4096 0x3016**

Bit(s)	R/W	Default	Description
20-0	R/W	0x0	Mx4096

**Table 9-233 VPU\_VLOCK\_STBDET\_WIN0\_WIN1 0x3017**

Bit(s)	R/W	Default	Description
15-8	R/W	0x0	Verr_stbdet_win1
7-0	R/W	0x0	Verr_stbdet_win0

**Table 9-234 VPU\_VLOCK\_STBDET\_CLP 0x3018**

Bit(s)	R/W	Default	Description
15-8	R	0x0	Read only, ro_verr_clp_win1, verr_clp number in win0
7-0	R	0x0	Read only, ro_verr_clp_win0, verr clp number in win1

**Table 9-235 VPU\_VLOCK\_STBDET\_ABS\_WIN0 0x3019**

Bit(s)	R/W	Default	Description
23-0	R	0x0	Read only, ro_verr_abs_win0

**Table 9-236 VPU\_VLOCK\_STBDET\_ABS\_WIN1 0x301a**

Bit(s)	R/W	Default	Description
23-0	R	0x0	Read only, ro_verr_abs_win1

**Table 9-237 VPU\_VLOCK\_STBDET\_SGN\_WIN0 0x301b**

Bit(s)	R/W	Default	Description
23-0	R	0x0	Read only, ro_verr_sgn_win0

**Table 9-238 VPU\_VLOCK\_STBDET\_SGN\_WIN1 0x301c**

Bit(s)	R/W	Default	Description
23-0	R	0x0	Read only, ro_verr_sgn_win1

**Table 9-239 VPU\_VLOCK\_ADJ\_EN\_SYNC\_CTRL 0x301d**

Bit(s)	R/W	Default	Description
31-24	R/W	0x0	PLL adjust enable signal sync ctrl, adj_en_for_pll_end, end counter of adj_en_pll signal fall to 0
23-16	R/W	0x0	PLL adjust enable signal sync ctrl, adj_en_for_pll_start, start counter of adj_en_pll signal go to 1, start must be larger than end
15-8	R/W	0x0	Adj_en_sync_latch_cnt, this is a delay to latch the adj_en signal
7-0	R/W	0x0	Adj_en_ext_cnt, extend the adj_en signal from vid_lock clock domain to pll sample domain, make sure it's wide enough

**Table 9-240 VPU\_VLOCK\_GCLK\_EN 0x301e**

Bit(s)	R/W	Default	Description
2	R/W	0x0	Ref clock enable
1	R/W	0x0	Vsout clk enable
0	R/W	0x0	Vsin clk enable

**Table 9-241 VPU\_VLOCK\_LOOP1\_ACCUM\_LMT 0x301f**

Bit(s)	R/W	Default	Description
26-0	R/W	0x0	LOOP1 accumulator limit



**Table 9-242 VPU\_VLOCK\_RO\_M\_INT\_FRAC 0x3020**

Bit(s)	R/W	Default	Description
29-16	R	0x0	Read only, m_int to PLL
13-0	R	0x0	Read only, m_frac to PLL

### 9.2.3.3 VIU Top-Level Registers

**Table 9-243 VIU\_SW\_RESET 0x1A01**

Bit(s)	R/W	Default	Description
31	R/W	0	Osd1 afbcd reset
30	R/W	0	hist_spl reset
29	R/W	0	Ldim stts reset
8	R/W	0	Vd2 Dos afbcd reset
7	R/W	0	vpp_reset
6	R/W	0	di_dsr1to2_reset
5	R/W	0	vd2_fmt_reset
4	R/W	0	vd2_reset
3	R/W	0	vd1_fmt_reset
2	R/W	0	vd1_reset
1	R/W	0	osd2_reset
0	R/W	0	osd1_reset

**Table 9-244 VIU\_SW\_RESET0 0x1A02**

Bit(s)	R/W	Default	Description
2	R/W	0	Vd1 Dos afbcd reset

**Table 9-245 VIU\_MISC\_CTRL0 0x1a06**

Bit(s)	R/W	Default	Description
17	R/W	0	Vdin0_wr_out_ctrl : 0: nr_inp to vdin 1: vdin wr dout
16	R/W	0	Afbc_inp_sel : 0: mif to INP 1: afbc to INP
16	R/W	0	di_mif0_en: vd1(afbc) to di post(if0) enable
8	R/W	0	vsync_int_ctrl : default = 0
6:5	R/W	2	0: close mif data 1: mif to tfbf_downscale: 2: mif to nr , 3: mif to tfbf_downscale & NR
4	R/W		Vpp_di_mif0_sel 0:buf0_data from di_mif0 1: buf0_data from din_post_din
0	R/W	0	scan_reg : default = 0

Table 9-246 VIU\_MISC\_CTRL1 0x1A07

Bit(s)	R/W	Default	Description
27-22	R/W	0	afbc gate clk ctrl
15:14	R/W	0	Mali afbcd clock gate control
12	R/W	0	Osd1 axi bus select 1 : select mali afbcd 0 : normal osd1
11:8	R/W	0	di_mad_en: di post to vpp enable
7-2	R/W	0	Afbc2 Clock gate control
1	R/W	0	1 : connect dos afbcd2 to vpp vd1, 0 : connect mif to vpp vd1
0	R/W	0	1 : Dos afbcd2 output to di ; 0 : dos afbcd2 output to vpp

Table 9-247 VIUB\_SW\_RESET 0x2001

Bit(s)	R/W	Default	Description
31	R/W	0	mcvecwr_mif_rst_n
30	R/W	0	reserved
29	R/W	0	reserved
28	R/W	0	di_cont_rd_mif_rst_n
27	R/W	0	di_cont_wr_mif_rst_n
26	R/W	0	reserved
25	R/W	0	reserved
24	R/W	0	vdin1_wr_rst_n
23	R/W	0	vdin0_wr_rst_n
22	R/W	0	nrin_mux_rst_n
21	R/W	0	vdin1_rst_n
20	R/W	0	vdin0_rst_n
19	R/W	0	di_mad_rst_n
18	R/W	0	di_mtn_rd_mif_rst_n
17	R/W	0	di_mtn_wr_mif_rst_n
16	R/W	0	di_chan2_mif_rst_n
15	R/W	0	dein_wr_mif_rst_n
14	R/W	0	di_nr_wr_mif_rst_n
13	R/W	0	di_mem_fmt_rst_n
12	R/W	0	di_mem_rst_n
11	R/W	0	di_inp_fmt_rst_n
10	R/W	0	di_inp_rst_n
9	R/W	0	di_if1_fmt_rst_n
8	R/W	0	di_if1_rst_n
7-0	R/W	0	RESERVED

**Table 9-248 VIUB\_SW\_RESET0 0x2002**

Bit(s)	R/W	Default	Description
3	R/W	0	di_axi_arb_rst_n
2	R/W	0	mcinford_mif_rst_n
1	R/W	0	mcinfowr_mif_rst_n
0	R/W	0	mcvecrd_mif_rst_n

**Table 9-249 VIUB\_MISC\_CTRL0 0x2006**

Bit(s)	R/W	Default	Description
17	R/W	0	input2pre enable: 1->di inp data from vdin0 0->di inp data from inp_afbc(see bit16)
16	R/W	0	AFBC_INP_SEL: 1->di inp_afbc data from afbc 0->di inp_afbc data from inp mif(DDR)
6:5	R/W	0	0:mask input 1:buf_data ->nr_dscale 2: buf_data->NR 3: buf_data->nr_dscale
4	R/W	0	0:post_din to buf 1: di_mif0 -> buf
3-2	R/W	0	Fix_disable:dein_wr_mif
1-0	R/W	0	Fix_disable: di_nr_wr_mif

**Table 9-250 VIUB\_GCLK\_CTRL0 0x2007**

Bit(s)	R/W	Default	Description
31:16	R/W	0	Reserved
15	R/W	0	Di_gate_all,for old di
14	R/W	1	Di_no_clk_gate,for old di
13	R/W	0	reserved
12	R/W	0	Di_post clock enable ,from div clock
11	R/W	0	Mcdi clock enable,from div clock
10	R/W	0	Div clock enable,di slow clock including di
9	R/W	0	Mad post clock enable,from mad clock
8	R/W	0	Mad pre clock enable,from mad clock
7:1	R/W		reserved
0	R/W	1	Def=1 di_top_wrap clk enable

**Table 9-251 VIUB\_GCLK\_CTRL1 0x2008**

Bit(s)	R/W	Default	Description
31:28	R/W	0	Reserved
27:26	R/W	0	Mcdi pre mif clock gate 2'b00: gate clock ,2'b01: close clock,2'b1x: always clock
25:24	R/W	0	Mtn mif clock gate 2'b00: gate clock ,2'b01: close clock,2'b1x: always clock
23:22	R/W	0	Nr wrmif clock gate 2'b00: gate clock ,2'b01: close clock,2'b1x: always clock
21:20	R/W	0	Chan rdmif clock gate 2'b00: gate clock ,2'b01: close clock,2'b1x: always clock

Bit(s)	R/W	Default	Description
19:18	R/W	0	Mem rdmif clock gate 2'b00: gate clock ,2'b01: close clock,2'b1x: always clock
17:16	R/W	0	Inp rdmif clock gate clock gate 2'b00: gate clock ,2'b01: close clock,2'b1x: always clock
15:14	R/W	0	reserved
13:12	R/W	0	Mcdi post clock gate 2'b00: gate clock ,2'b01: close clock,2'b1x: always clock
11-10	R/W	0	Mtnrd post mif clock gate 2'b00: gate clock ,2'b01: close clock,2'b1x: always clock
9-8	R/W	0	De wrmif clock gate 2'b00: gate clock ,2'b01: close clock,2'b1x: always clock
7-6	R/W	0	if2 rdmif clock gate 2'b00: gate clock ,2'b01: close clock,2'b1x: always clock
5-4	R/W	0	lf1 rdmif clock gate 2'b00: gate clock ,2'b01: close clock,2'b1x: always clock
3-2	R/W	0	lf0 rdmif clock gate 2'b00: gate clock ,2'b01: close clock,2'b1x: always clock
1-0	R/W	0	Mif-sub-arb clock gate 2'b00: gate clock ,2'b01: close clock,2'b1x: always clock

Table 9-252 VIUB\_GCLK\_CTRL2 0x2009

Bit(s)	R/W	Default	Description
31-14	R/W	0	reserved
13-12	R/W	0	mcdi clock gate ctrl 2'b00: gate clock ,2'b01: close clock,2'b1x: always clock
11:10	R/W	0	Nr blend clock gate ctrl 2'b00: gate clock ,2'b01: close clock,2'b1x: always clock
9-8	R/W	0	Dnr clock gate ctrl 2'b00: gate clock ,2'b01: close clock,2'b1x: always clock
7-6	R/W	0	nning clock gate ctrl 2'b00: gate clock ,2'b01: close clock,2'b1x: always clock
5-4	R/W	0	Mtn det clock gate ctrl 2'b00: gate clock ,2'b01: close clock,2'b1x: always clock
3-2	R/W	0	pd clock gate ctrl 2'b00: gate clock ,2'b01: close clock,2'b1x: always clock
1-0	R/W	0	Nr clock gate ctrl 2'b00: gate clock ,2'b01: close clock,2'b1x: always clock

Table 9-253 VIUB\_GCLK\_CTRL3 0x200a

Bit(s)	R/W	Default	Description
31-6	R/W	0	Reserved
5-4	R/W	0	Di blend clock gate ctrl 2'b00: gate clock ,2'b01: close clock,2'b1x: always clock
3-2	R/W	0	Ei clock gate ctrl 2'b00: gate clock ,2'b01: close clock,2'b1x: always clock
1-0	R/W	0	Ei_0 clock gate ctrl 2'b00: gate clock ,2'b01: close clock,2'b1x: always clock

Table 9-254 DI\_DBG\_CTRL 0x200B

Bit(s)	R/W	Default	Description
31:7	R/W	0	Reserved
6	R/W	0	go_field_sel : 1: post_frame_rst 0: pre_frame_rst
5:0	R/W	0	Debug_sel :

**Table 9-255 DI\_DBG\_CTRL1 0x200C**

Bit(s)	R/W	Default	Description
31:16	R/W	0	Rrdy_to_srdy_max_num
15:0	R/W	0	Srdy_to_rrdy_max_num

**Table 9-256 DI\_DBG\_SRDY\_INF 0x200D**

Bit(s)	R/W	Default	Description
31:16	RO	0	wait_rrdy_bmax_dbg_cnt
15:0	RO	0	Srdy_to_rrdy_dbg_cnt

**Table 9-257 DI\_DBG\_RRDY\_INF 0x200E**

Bit(s)	R/W	Default	Description
31:16	RO	0	Wait_srdy_bmax_dbg_cnt
15:0	RO	0	Rrdy_to_srdy_dbg_cnt

**Table 9-258 VIU\_MISC\_CTRL1 0x3107**

Bit(s)	R/W	Default	Description
15:14	R/W	0x0	mali_afbcd_gclk_ctrl : mali_afbcd clock gate control[5:4]
12	R/W	0x0	osd1_afbcd_axi_mux : 0 : use the osd mif as input; 1 : use afbcd as input
11:8	R/W	0x0	mali_afbcd_gclk_ctrl : mali_afbcd clock gate control[3:0]
7:2	R/W	0x0	vd2_afbcd_gclk_ctrl : vd2_afbcd clock gate control
1	R/W	0x0	vpp_vd2_din_sel : 0: vpp vd2 sel the mif input; 1: vpp vd2 sel the dos afbcd
0	R/W	0x0	vd2_afbcd_out_sel : 0: vd2_afbcd output to vpp; 1 : vd2_afbcd output to di inp

### 9.2.3.4 DI\_AXI\_ARB Registers

**Table 9-259 DI\_RDARB\_MODE\_L1C1 0x2050**

Bit(s)	R/W	Default	Description
21:16	R/W	0	rdarb_sel : uns, default = 0 , rdarb_sel [0]==0 slave dc0 connect master port0 rdarb_sel[0]==1 slave dc0 connect master port1 rdarb_sel [1]==0 slave dc1 connect master port0 rdarb_sel[1]==1 slave dc1 connect master port1 rdarb_sel [2]==0 slave dc2 connect master port0 rdarb_sel[2]==1 slave dc2 connect master port1 rdarb_sel [3]==0 slave dc3 connect master port0 rdarb_sel[3]==1 slave dc3 connect master port1 rdarb_sel [4]==0 slave dc4 connect master port0 rdarb_sel [4]==1 slave dc4 connect master port1 rdarb_sel [5]==0 slave dc5 connect master port0 rdarb_sel[5]==1 slave dc5 connect master port1
9:8	R/W	0	rdarb_arb_mode : uns, default = 0 , rdarb_arb_mode [0] master port0 arb way, rdarb_arb_mode [1] master port1 arb way,
3:0	R/W	0	rdarb_gate_clk_ctrl : uns, default = 0 , rdarb_gate_clk_ctrl [1:0] master port0 clk gate control rdarb_gate_clk_ctrl [3:2] master port1 clk gate control

Table 9-260 DI\_RDARB\_REQEN\_SLV\_L1C1 0x2051

Bit(s)	R/W	Default	Description
11:0	R/W	0xffff	rdarb_dc_req_en : unsigned , default = 12'hfff rdarb_dc_req_en [0]: the slv0 req to mst port0 enable, rdarb_dc_req_en [1]: the slv1 req to mst port0 enable, rdarb_dc_req_en [2]: the slv2 req to mst port0 enable, rdarb_dc_req_en [3]: the slv3 req to mst port0 enable, rdarb_dc_req_en [4]: the slv4 req to mst port0 enable, rdarb_dc_req_en [5]: the slv5 req to mst port0 enable, rdarb_dc_req_en [6]: the slv0 req to mst port1 enable, rdarb_dc_req_en [7]: the slv1 req to mst port1 enable, rdarb_dc_req_en [8]: the slv2 req to mst port1 enable, rdarb_dc_req_en [9]: the slv3 req to mst port1 enable, rdarb_dc_req_en [10]: the slv4 req to mst port1 enable, rdarb_dc_req_en [11]: the slv5 req to mst port1 enable,

Table 9-261 DI\_RDARB\_WEIGH0\_SLV\_L1C1 0x2052

Bit(s)	R/W	Default	Description
29:0	R/W	0	rddc_weigh_sxn : unsigned , default = 0 rddc_weigh_sxn [0*6+:6]: the slv0 req weigh number rddc_weigh_sxn [1*6+:6]: the slv1 req weigh number rddc_weigh_sxn [2*6+:6]: the slv2 req weigh number rddc_weigh_sxn [3*6+:6]: the slv3 req weigh number rddc_weigh_sxn [4*6+:6]: the slv4 req weigh number

Table 9-262 DI\_RDARB\_WEIGH1\_SLV\_L1C1 0x2053

Bit(s)	R/W	Default	Description
5:0	R/W	0	rddc_weigh_sxn : unsigned , default = 0 rddc_weigh_sxn [5*6+:6]: the slv5 req weigh number

Table 9-263 DI\_WRARB\_MODE\_L1C1 0x2054

Bit(s)	R/W	Default	Description
21:16	R/W	0	wrarb_sel : uns, default = 0 , wrarb_sel [0]==0 slave dc0 connect master port0 wrarb_sel[0]==1 slave dc0 connect master port1 wrarb_sel [1]==0 slave dc1 connect master port0 wrarb_sel [1]==1 slave dc1 connect master port1 wrarb_sel [2]==0 slave dc2 connect master port0 wrarb_sel [2]==1 slave dc2 connect master port1 wrarb_sel [3]==0 slave dc3 connect master port0 wrarb_sel [3]==1 slave dc3 connect master port1 wrarb_sel [4]==0 slave dc4 connect master port0 wrarb_sel [4]==1 slave dc4 connect master port1 wrarb_sel [5]==0 slave dc5 connect master port0 wrarb_sel [5]==1 slave dc5 connect master port1
9:8	R/W	0	wrarb_arb_mode : uns, default = 0 , wrarb_arb_mode [0] master port0 arb way, wrarb_arb_mode [1] master port1 arb way,
3:0	R/W	0	wrarb_gate_clk_ctrl : uns, default = 0 , wrarb_gate_clk_ctrl [1:0] master port0 clk gate control wrarb_gate_clk_ctrl [3:2] master port1 clk gate control

Table 9-264 DI\_WRARB\_REQEN\_SLV\_L1C1 0x2055

Bit(s)	R/W	Default	Description
11:0	R/W	0	wrarb_dc_req_en : unsigned , default = 0 wrarb_dc_req_en [0]: the slv0 req to mst port0 enable, wrarb_dc_req_en [1]: the slv1 req to mst port0 enable, wrarb_dc_req_en [2]: the slv2 req to mst port0 enable, wrarb_dc_req_en [3]: the slv3 req to mst port0 enable, wrarb_dc_req_en [4]: the slv4 req to mst port0 enable, wrarb_dc_req_en [5]: the slv5 req to mst port0 enable, wrarb_dc_req_en [0]: the slv0 req to mst port1 enable, wrarb_dc_req_en [1]: the slv1 req to mst port1 enable, wrarb_dc_req_en [2]: the slv2 req to mst port1 enable, wrarb_dc_req_en [3]: the slv3 req to mst port1 enable, wrarb_dc_req_en [4]: the slv4 req to mst port1 enable, wrarb_dc_req_en [5]: the slv5 req to mst port1 enable,

Table 9-265 DI\_WRARB\_WEIGHT0\_SLV\_L1C1 0x2056

Bit(s)	R/W	Default	Description
29:0	R/W	0	wrdc_weigh_sxn : unsigned , default = 0 wrdc_weigh_sxn [0*6+:6]: the slv0 req weigh number wrdc_weigh_sxn [1*6+:6]: the slv1 req weigh number wrdc_weigh_sxn [2*6+:6]: the slv2 req weigh number wrdc_weigh_sxn [3*6+:6]: the slv3 req weigh number wrdc_weigh_sxn [4*6+:6]: the slv4 req weigh number

Table 9-266 DI\_WRARB\_WEIGHT1\_SLV\_L1C1 0x2057

Bit(s)	R/W	Default	Description
5:0	R/W	0	wrdc_weigh_sxn : unsigned , default = 0 wrdc_weigh_sxn [5*6+:6]: the slv5 req weigh number

Table 9-267 DI\_RDWR\_ARB\_STATUS\_L1C1 0x2058

Bit(s)	R/W	Default	Description
3:2	R/W	0	wrarb_arb_busy : unsigned , default = 0
1:0	R/W	0	rdarb_arb_busy : unsigned , default = 0

Table 9-268 DI\_ARB\_DBG\_CTRL\_L1C1 0x2059

Bit(s)	R/W	Default	Description
31:0	R/W	8	det_cmd_ctrl : unsigned , default = 8

Table 9-269 DI\_ARB\_DBG\_STAT\_L1C1 0x205a

Bit(s)	R/W	Default	Description
31:0	R/W	0	det_dbg_stat : unsigned , default = 0

Table 9-270 DI\_RDARB\_UGT\_L1C1 0x205b

Bit(s)	R/W	Default	Description
15:0	R/W	0x0	rdarb_ugt_basic : unsigned , default = {8{2'b1}};

Table 9-271 DI\_RDARB\_LIMT0\_L1C1 0x205c

Bit(s)	R/W	Default	Description
31:0	R/W	0x0	rdarb_req_limt_num : unsigned , default = {2{16'h3f3f}};

Table 9-272 DI\_WRARB\_UGT\_L1C1 0x205d

Bit(s)	R/W	Default	Description
11:0	R/W	0	wrarb_ugt_basic : unsigned , default = 0

Table 9-273 DI\_SUB\_RDARB\_MODE 0x37c0

Bit(s)	R/W	Default	Description
23:16	R/W	0	rdarb_sel : uns, default = 0 , rdarb_sel [0]==0 slave dc0 connect master port0 rdarb_sel[0]==1 slave dc0 connect master port1 rdarb_sel [1]==0 slave dc1 connect master port0 rdarb_sel[1]==1 slave dc1 connect master port1 rdarb_sel [2]==0 slave dc2 connect master port0 rdarb_sel[2]==1 slave dc2 connect master port1 rdarb_sel [3]==0 slave dc3 connect master port0 rdarb_sel[3]==1 slave dc3 connect master port1 rdarb_sel [4]==0 slave dc4 connect master port0 rdarb_sel [4]==1 slave dc4 connect master port1 rdarb_sel [5]==0 slave dc5 connect master port0 rdarb_sel[5]==1 slave dc5 connect master port1 rdarb_sel [6]==0 slave dc5 connect master port0 rdarb_sel[6]==1 slave dc6 connect master port1 rdarb_sel [7]==0 slave dc5 connect master port0 rdarb_sel[7]==1 slave dc7 connect master port1
9:8	R/W	0	rdarb_arb_mode : uns, default = 0 , rdarb_arb_mode [0] master port0 arb way, rdarb_arb_mode [1] master port1 arb way,
3:0	R/W	0	rdarb_gate_clk_ctrl : uns, default = 0 , rdarb_gate_clk_ctrl [1:0] master port0 clk gate control rdarb_gate_clk_ctrl [3:2] master port1 clk gate control

Table 9-274 DI\_SUB\_RDARB\_REQEN\_SLV 0x37c1

Bit(s)	R/W	Default	Description
15:0	R/W	0xffff	rdarb_dc_req_en : uns, default = 16'hffff , slv0~slv7 enable to mst.

Table 9-275 DI\_SUB\_RDARB\_WEIGHT0\_SLV 0x37c2

Bit(s)	R/W	Default	Description
29:0	R/W	0	rddc_weigh_sxn : unsigned , default = 0 rddc_weigh_sxn [0*6+:6]: the slv0 req weigh number rddc_weigh_sxn [1*6+:6]: the slv1 req weigh number rddc_weigh_sxn [2*6+:6]: the slv2 req weigh number rddc_weigh_sxn [3*6+:6]: the slv3 req weigh number rddc_weigh_sxn [4*6+:6]: the slv4 req weigh number

Table 9-276 DI\_SUB\_RDARB\_WEIGHT1\_SLV 0x37c3

Bit(s)	R/W	Default	Description
17:0	R/W	0	rddc_weigh_sxn : unsigned , default = 0 rddc_weigh_sxn [0*6+:6]: the slv6 req weigh number rddc_weigh_sxn [1*6+:6]: the slv7 req weigh number rddc_weigh_sxn [2*6+:6]: the slv8 req weigh number



Table 9-277 DI\_SUB\_RDARB\_UGT 0x37c4

Bit(s)	R/W	Default	Description
15:0	R/W	0x0	rdarb_ugt_basic : unsigned , default = {8'2'h1} rdarb_ugt_basic [0*1+:2]: 00 : use auto fifo arugt generate the output arugt. 01 : use the register bit control 10 : use the input arguen rdarb_ugt_basic [1*2+:2]: 00 : use auto fifo arugt generate the output arugt. 01 : use the register bit control 10 : use the input arguen rdarb_ugt_basic [2*2+:2]: 00 : use auto fifo arugt generate the output arugt. 01 : use the register bit control 10 : use the input arguen rdarb_ugt_basic [3*2+:2]: 00 : use auto fifo arugt generate the output arugt. 01 : use the register bit control 10 : use the input arguen rdarb_ugt_basic [4*2+:2]: 00 : use auto fifo arugt generate the output arugt. 01 : use the register bit control 10 : use the input arguen rdarb_ugt_basic [5*2+:2]: 00 : use auto fifo arugt generate the output arugt. 01 : use the register bit control 10 : use the input arguen rdarb_ugt_basic [6*2+:2]: 00 : use auto fifo arugt generate the output arugt. 01 : use the register bit control 10 : use the input arguen rdarb_ugt_basic [7*2+:2]: 00 : use auto fifo arugt generate the output arugt. 01 : use the register bit control 10 : use the input arguen

Table 9-278 DI\_SUB\_RDARB\_LIMT0 0x37c5

Bit(s)	R/W	Default	Description
31:0	R/W	0x0	rdarb_req_limt_num : unsigned , default = {2'16'h3f3f}

Table 9-279 DI\_SUB\_WRARB\_MODE 0x37c6

Bit(s)	R/W	Default	Description
21:16	R/W	0	wrarb_sel : uns, default = 0 , wrarb_sel [0]==0 slave dc0 connect master port0 wrarb_sel[0]==1 slave dc0 connect master port1 wrarb_sel [1]==0 slave dc1 connect master port0 wrarb_sel[1]==1 slave dc1 connect master port1 wrarb_sel [2]==0 slave dc2 connect master port0 wrarb_sel[2]==1 slave dc2 connect master port1 wrarb_sel [3]==0 slave dc3 connect master port0 wrarb_sel[3]==1 slave dc3 connect master port1 wrarb_sel [4]==0 slave dc4 connect master port0 wrarb_sel[4]==1 slave dc3 connect master port1 wrarb_sel [5]==0 slave dc5 connect master port0 wrarb_sel[5]==1 slave dc3 connect master port1
8	R/W	0	wrarb_arb_mode : uns, default = 0 , wrarb_arb_mode[0] master port0 arb way,
1:0	R/W	0	wrarb_gate_clk_ctrl : uns, default = 0 , wrarb_gate_clk_ctrl[1:0] master port0 clk gate control

Table 9-280 DI\_SUB\_WRARB\_REQEN\_SLV 0x37c7

Bit(s)	R/W	Default	Description
5:0	R/W	0	wrarb_dc_req_en : unsigned , default = 0 wrarb_dc_req_en [0]: the slv0 req to mst port0 enable, wrarb_dc_req_en [1]: the slv1 req to mst port0 enable, wrarb_dc_req_en [2]: the slv2 req to mst port0 enable, wrarb_dc_req_en [0]: the slv0 req to mst port1 enable, wrarb_dc_req_en [1]: the slv1 req to mst port1 enable, wrarb_dc_req_en [2]: the slv2 req to mst port1 enable,

Table 9-281 DI\_SUB\_WRARB\_WEIGH0\_SLV 0x37c8

Bit(s)	R/W	Default	Description
29:0	R/W	0	wrdc_weigh_sxn : unsigned , default = 0 wrdc_weigh_sxn [0*6+:6]: the slv0 req weigh number wrdc_weigh_sxn [1*6+:6]: the slv1 req weigh number wrdc_weigh_sxn [2*6+:6]: the slv2 req weigh number wrdc_weigh_sxn [3*6+:6]: the slv3 req weigh number wrdc_weigh_sxn [4*6+:6]: the slv4 req weigh number

Table 9-282 DI\_SUB\_WRARB\_WEIGHT1\_SLV 0x37c9

Bit(s)	R/W	Default	Description
5:0	R/W	0	wrdc_weigh_sxn : unsigned , default = 0 the slv5 req weigh number

Table 9-283 DI\_SUB\_WRARB\_UGT 0x37ca

Bit(s)	R/W	Default	Description
11:0	R/W	0x0	rdarb_ugt_basic : unsigned , default = {8{2'h1}} rdarb_ugt_basic [0*1+:2]: 00 : use auto fifo arugt generate the output arugt. 01 : use the register bit control 10 : use the input arguen rdarb_ugt_basic [1*2+:2]: 00 : use auto fifo arugt generate the output arugt. 01 : use the register bit control 10 : use the input arguen rdarb_ugt_basic [2*2+:2]: 00 : use auto fifo arugt generate the output arugt. 01 : use the register bit control 10 : use the input arguen rdarb_ugt_basic [3*2+:2]: 00 : use auto fifo arugt generate the output arugt. 01 : use the register bit control 10 : use the input arguen rdarb_ugt_basic [4*2+:2]: 00 : use auto fifo arugt generate the output arugt. 01 : use the register bit control 10 : use the input arguen rdarb_ugt_basic [5*2+:2]: 00 : use auto fifo arugt generate the output arugt. 01 : use the register bit control 10 : use the input arguen

Table 9-284 DI\_SUB\_RDWR\_ARB\_STATUS 0x37cb

Bit(s)	R/W	Default	Description
2	R.O	0	ro_wrarb_arb_busy : unsigned , default = 0
1	R/W	0x0	reserve :
0	R.O	0	ro_rdarb_arb_busy : unsigned , default = 0

Table 9-285 DI\_SUB\_ARB\_DBG\_CTRL 0x37cc

Bit(s)	R/W	Default	Description
31:0	R.O	0	ro_det_cmd_ctrl : unsigned , default = 0

Table 9-286 DI\_SUB\_ARB\_DBG\_STAT 0x37cd

Bit(s)	R/W	Default	Description
31:0	R.O	0	ro_det_dbg_stat : unsigned , default = 0

Table 9-287 CONTRD\_CTRL1 0x37d0

Bit(s)	R/W	Default	Description
25:24	R/W	0	reg_sync_sel : unsigned , default = 0
23:16	R/W	0	reg_canvas_id : unsigned , default = 0
14:12	R/W	1	reg_cmd_intr_len : unsigned , default = 1
11:10	R/W	1	reg_cmd_req_size : unsigned , default = 1
9:8	R/W	2	reg_burst_len : unsigned , default = 2
7	R/W	0	reg_swap_64bit : unsigned , default = 0
6	R/W	0	reg_little_endian : unsigned , default = 0

Bit(s)	R/W	Default	Description
5	R/W	0	reg_y_rev : unsigned , default = 0
4	R/W	0	reg_x_rev : unsigned , default = 0
2:0	R/W	1	reg_pack_mode : unsigned , default = 1

Table 9-288 CONTRD\_CTRL2 0x37d1

Bit(s)	R/W	Default	Description
31:30	R/W	0	reg_sw_rst : unsigned , default = 0
23:18	R/W	0	reg_gclk_ctrl : unsigned , default = 0
16	R/W	0	urgent
15	R/W	0	auto_urgent_en
14	R/W	0	urgent_wr
7:4	R/W	0	up_th
3:0	R/W	0	dn_th

Table 9-289 CONTRD\_SCOPE\_X 0x37d2

Bit(s)	R/W	Default	Description
28:16	R/W	0	reg_x_end : unsigned , default = 0
12:0	R/W	0	reg_x_start : unsigned , default = 0

Table 9-290 CONTRD\_SCOPE\_Y 0x37d3

Bit(s)	R/W	Default	Description
28:16	R/W	0	reg_y_end : unsigned , default = 0
12:0	R/W	0	reg_y_start : unsigned , default = 0

Table 9-291 CONTRD\_RO\_STAT 0x37d4

Bit(s)	R/W	Default	Description
15:0	R.O	0	ro_reg_status : unsigned , default = 0

Table 9-292 CONT2RD\_CTRL1 0x37d5

Bit(s)	R/W	Default	Description
25:24	R/W	0	reg_sync_sel : unsigned , default = 0
23:16	R/W	0	reg_canvas_id : unsigned , default = 0
14:12	R/W	1	reg_cmd_intr_len : unsigned , default = 1
11:10	R/W	1	reg_cmd_req_size : unsigned , default = 1

Bit(s)	R/W	Default	Description
9:8	R/W	2	reg_burst_len : unsigned , default = 2
7	R/W	0	reg_swap_64bit : unsigned , default = 0
6	R/W	0	reg_little_endian : unsigned , default = 0
5	R/W	0	reg_y_rev : unsigned , default = 0
4	R/W	0	reg_x_rev : unsigned , default = 0
2:0	R/W	1	reg_pack_mode : unsigned , default = 1

Table 9-293 CONT2RD\_CTRL2 0x37d6

Bit(s)	R/W	Default	Description
31:30	R/W	0	reg_sw_rst : unsigned , default = 0
23:18	R/W	0	reg_gclk_ctrl : unsigned , default = 0
16	R/W	0	urgent
15	R/W	0	auto_urgent_en
14	R/W	0	urgent_wr
7:4	R/W	0	up_th
3:0	R/W	0	dn_th

Table 9-294 CONT2RD\_SCOPE\_X 0x37d7

Bit(s)	R/W	Default	Description
28:16	R/W	0	reg_x_end : unsigned , default = 0
12:0	R/W	0	reg_x_start : unsigned , default = 0

Table 9-295 CONT2RD\_SCOPE\_Y 0x37d8

Bit(s)	R/W	Default	Description
28:16	R/W	0	reg_y_end : unsigned , default = 0
12:0	R/W	0	reg_y_start : unsigned , default = 0

Table 9-296 CONT2RD\_RO\_STAT 0x37d9

Bit(s)	R/W	Default	Description
15:0	R.O	0	ro_reg_status : unsigned , default = 0

**Table 9-297 MTNRD\_CTRL1 0x37da**

Bit(s)	R/W	Default	Description
25:24	R/W	0	reg_sync_sel : unsigned , default = 0
23:16	R/W	0	reg_canvas_id : unsigned , default = 0
14:12	R/W	1	reg_cmd_intr_len : unsigned , default = 1
11:10	R/W	1	reg_cmd_req_size : unsigned , default = 1
9:8	R/W	2	reg_burst_len : unsigned , default = 2
7	R/W	0	reg_swap_64bit : unsigned , default = 0
6	R/W	0	reg_little_endian : unsigned , default = 0
5	R/W	0	reg_y_rev : unsigned , default = 0
4	R/W	0	reg_x_rev : unsigned , default = 0
2:0	R/W	1	reg_pack_mode : unsigned , default = 1

**Table 9-298 MTNRD\_CTRL2 0x37db**

Bit(s)	R/W	Default	Description
31:30	R/W	0	reg_sw_rst : unsigned , default = 0
23:18	R/W	0	reg_gclk_ctrl : unsigned , default = 0
16	R/W	0	urgent
15	R/W	0	auto_urgent_en
14	R/W	0	urgent_wr
7:4	R/W	0	up_th
3:0	R/W	0	dn_th

**Table 9-299 MTNRD\_SCOPE\_X 0x37dc**

Bit(s)	R/W	Default	Description
28:16	R/W	0	reg_x_end : unsigned , default = 0
12:0	R/W	0	reg_x_start : unsigned , default = 0

**Table 9-300 MTNRD\_SCOPE\_Y 0x37dd**

Bit(s)	R/W	Default	Description
28:16	R/W	0	reg_y_end : unsigned , default = 0
12:0	R/W	0	reg_y_start : unsigned , default = 0

**Table 9-301 MTNRD\_RO\_STAT 0x37de**

Bit(s)	R/W	Default	Description
15:0	R.O	0	ro_reg_status : unsigned , default = 0

**Table 9-302 MCVECRD\_CTRL1 0x37df**

Bit(s)	R/W	Default	Description
25:24	R/W	0	reg_sync_sel : unsigned , default = 0
23:16	R/W	0	reg_canvas_id : unsigned , default = 0
14:12	R/W	1	reg_cmd_intr_len : unsigned , default = 1
11:10	R/W	1	reg_cmd_req_size : unsigned , default = 1
9:8	R/W	2	reg_burst_len : unsigned , default = 2
7	R/W	0	reg_swap_64bit : unsigned , default = 0
6	R/W	0	reg_little_endian : unsigned , default = 0
5	R/W	0	reg_y_rev : unsigned , default = 0
4	R/W	0	reg_x_rev : unsigned , default = 0
2:0	R/W	1	reg_pack_mode : unsigned , default = 1

**Table 9-303 MCVECRD\_CTRL2 0x37e0**

Bit(s)	R/W	Default	Description
31:30	R/W	0	reg_sw_rst : unsigned , default = 0
23:18	R/W	0	reg_gclk_ctrl : unsigned , default = 0
16	R/W	0	urgent
15	R/W	0	auto_urgent_en
14	R/W	0	urgent_wr
7:4	R/W	0	up_th
3:0	R/W	0	dn_th

**Table 9-304 MCVECRD\_SCOPE\_X 0x37e1**

Bit(s)	R/W	Default	Description
28:16	R/W	0	reg_x_end : unsigned , default = 0
12:0	R/W	0	reg_x_start : unsigned , default = 0

**Table 9-305 MCVECRD\_SCOPE\_Y 0x37e2**

Bit(s)	R/W	Default	Description
28:16	R/W	0	reg_y_end : unsigned , default = 0
12:0	R/W	0	reg_y_start : unsigned , default = 0

**Table 9-306 MCVECRD\_RO\_STAT 0x37e3**

Bit(s)	R/W	Default	Description
15:0	R.O	0	ro_reg_status : unsigned , default = 0

**Table 9-307 MCINFRD\_CTRL1 0x37e4**

Bit(s)	R/W	Default	Description
25:24	R/W	0	reg_sync_sel : unsigned , default = 0
23:16	R/W	0	reg_canvas_id : unsigned , default = 0
14:12	R/W	1	reg_cmd_intr_len : unsigned , default = 1
11:10	R/W	1	reg_cmd_req_size : unsigned , default = 1
9:8	R/W	2	reg_burst_len : unsigned , default = 2
7	R/W	0	reg_swap_64bit : unsigned , default = 0
6	R/W	0	reg_little_endian : unsigned , default = 0
5	R/W	0	reg_y_rev : unsigned , default = 0
4	R/W	0	reg_x_rev : unsigned , default = 0
2:0	R/W	1	reg_pack_mode : unsigned , default = 1

**Table 9-308 MCINFRD\_CTRL2 0x37e5**

Bit(s)	R/W	Default	Description
31:30	R/W	0	reg_sw_rst : unsigned , default = 0
23:18	R/W	0	reg_gclk_ctrl : unsigned , default = 0
16	R/W	0	urgent
15	R/W	0	auto_urgent_en
14	R/W	0	urgent_wr
7:4	R/W	0	up_th
3:0	R/W	0	dn_th

**Table 9-309 MCINFRD\_SCOPE\_X 0x37e6**

Bit(s)	R/W	Default	Description
28:16	R/W	0	reg_x_end : unsigned , default = 0
12:0	R/W	0	reg_x_start : unsigned , default = 0

**Table 9-310 MCINFRD\_SCOPE\_Y 0x37e7**

Bit(s)	R/W	Default	Description
28:16	R/W	0	reg_y_end : unsigned , default = 0
12:0	R/W	0	reg_y_start : unsigned , default = 0

**Table 9-311 MCINFRD\_RO\_STAT 0x37e8**

Bit(s)	R/W	Default	Description
15:0	R.O	0	ro_reg_status : unsigned , default = 0

**Table 9-312 CONTWR\_X 0x37e9**

Bit(s)	R/W	Default	Description
31:30	R/W	2	burst_len : unsigned , default = 2
29	R/W	0	rev_x : unsigned , default = 0
28:16	R/W	0	start_x : unsigned , default = 0
12:0	R/W	2	end_x : unsigned , default = 2cf

**Table 9-313 CONTWR\_Y 0x37ea**

Bit(s)	R/W	Default	Description
31:30	R/W	0	canvas_id : unsigned , default = 0
29	R/W	0	rev_y : unsigned , default = 0
28:16	R/W	0	start_y : unsigned , default = 0
12:0	R/W	0	end_y : unsigned , default = 0x1df

**Table 9-314 CONTWR\_CTRL 0x37eb**

Bit(s)	R/W	Default	Description
31:16	R/W	0	urgent_ctrl : unsigned , default = 0
15	R/W	0	force_wvalid : unsigned , default = 0
14	R/W	0	canvas_syncen : unsigned , default = 0
13	R/W	1	canvas_wr : unsigned , default = 1
12	R/W	0	req_en : unsigned , default = 0
10	R/W	0	clr_wrrsp : unsigned , default = 0
8	R/W	0	urgent : unsigned , default = 0
7:0	R/W	0	canvas_index : unsigned , default = 0

**Table 9-315 CONTWR\_CAN\_SIZE 0x37ec**

Bit(s)	R/W	Default	Description
30:29	R/W	0	reg_rst : unsigned , default = 0
28:16	R/W	0	hsizem1 : unsigned , default = 0x2cf
14	R/W	0	reg_reset : unsigned , default = 0



Bit(s)	R/W	Default	Description
13	R/W	0	little_endian : unsigned , default = 0
12:0	R/W	0	vsizem1 : unsigned , default = 0x1df

Table 9-316 MTNWR\_X 0x37ed

Bit(s)	R/W	Default	Description
31:30	R/W	2	burst_len : unsigned , default = 2
29	R/W	0	rev_x : unsigned , default = 0
28:16	R/W	0	start_x : unsigned , default = 0
12:0	R/W	2	end_x : unsigned , default = 2cf

Table 9-317 MTNWR\_Y 0x37ee

Bit(s)	R/W	Default	Description
31:30	R/W	0	canvas_id : unsigned , default = 0
29	R/W	0	rev_y : unsigned , default = 0
28:16	R/W	0	start_y : unsigned , default = 0
12:0	R/W	0	end_y : unsigned , default = 0x1df

Table 9-318 MTNWR\_CTRL 0x37ef

Bit(s)	R/W	Default	Description
31:16	R/W	0	urgent_ctrl : unsigned , default = 0
15	R/W	0	force_wvalid : unsigned , default = 0
14	R/W	0	canvas_syncen : unsigned , default = 0
13	R/W	1	canvas_wr : unsigned , default = 1
12	R/W	0	req_en : unsigned , default = 0
10	R/W	0	clr_wrrsp : unsigned , default = 0
8	R/W	0	urgent : unsigned , default = 0
7:0	R/W	0	canvas_index : unsigned , default = 0

Table 9-319 MTNWR\_CAN\_SIZE 0x37f0

Bit(s)	R/W	Default	Description
30:29	R/W	0	reg_rst : unsigned , default = 0
28:16	R/W	0	hsizem1 : unsigned , default = 0x2cf
14	R/W	0	reg_reset : unsigned , default = 0
13	R/W	0	little_endian : unsigned , default = 0
12:0	R/W	0	vsizem1 : unsigned , default = 0x1df

**Table 9-320 MCVECWR\_X 0x37f1**

Bit(s)	R/W	Default	Description
31:30	R/W	2	burst_len : unsigned , default = 2
29	R/W	0	rev_x : unsigned , default = 0
28:16	R/W	0	start_x : unsigned , default = 0
12:0	R/W	2	end_x : unsigned , default = 2cf

**Table 9-321 MCVECWR\_Y 0x37f2**

Bit(s)	R/W	Default	Description
31:30	R/W	0	canvas_id : unsigned , default = 0
29	R/W	0	rev_y : unsigned , default = 0
28:16	R/W	0	start_y : unsigned , default = 0
12:0	R/W	0	end_y : unsigned , default = 0x1df

**Table 9-322 MCVECWR\_CTRL 0x37f3**

Bit(s)	R/W	Default	Description
31:16	R/W	0	urgent_ctrl : unsigned , default = 0
15	R/W	0	force_wvalid : unsigned , default = 0
14	R/W	0	canvas_syncen : unsigned , default = 0
13	R/W	1	canvas_wr : unsigned , default = 1
12	R/W	0	req_en : unsigned , default = 0
10	R/W	0	clr_wrrsp : unsigned , default = 0
8	R/W	0	urgent : unsigned , default = 0
7:0	R/W	0	canvas_index : unsigned , default = 0

**Table 9-323 MCVECWR\_CAN\_SIZE 0x37f4**

Bit(s)	R/W	Default	Description
30:29	R/W	0	reg_rst : unsigned , default = 0
28:16	R/W	0	hsizem1 : unsigned , default = 0x2cf
14	R/W	0	reg_reset : unsigned , default = 0
13	R/W	0	little_endian : unsigned , default = 0
12:0	R/W	0	vsizem1 : unsigned , default = 0x1df

**Table 9-324 MCINFWR\_X 0x37f5**

Bit(s)	R/W	Default	Description
31:30	R/W	2	burst_len : unsigned , default = 2
29	R/W	0	rev_x : unsigned , default = 0
28:16	R/W	0	start_x : unsigned , default = 0
12:0	R/W	2	end_x : unsigned , default = 2cf

**Table 9-325 MCINFWR\_Y 0x37f6**

Bit(s)	R/W	Default	Description
31:30	R/W	0	canvas_id : unsigned , default = 0
29	R/W	0	rev_y : unsigned , default = 0
28:16	R/W	0	start_y : unsigned , default = 0
12:0	R/W	0	end_y : unsigned , default = 0x1df

**Table 9-326 MCINFWR\_CTRL 0x37f7**

Bit(s)	R/W	Default	Description
31:16	R/W	0	urgent_ctrl : unsigned , default = 0
15	R/W	0	force_wvalid : unsigned , default = 0
14	R/W	0	canvas_syncen : unsigned , default = 0
13	R/W	1	canvas_wr : unsigned , default = 1
12	R/W	0	req_en : unsigned , default = 0
10	R/W	0	clr_wrrsp : unsigned , default = 0
8	R/W	0	urgent : unsigned , default = 0
7:0	R/W	0	canvas_index : unsigned , default = 0

**Table 9-327 MCINFWR\_CAN\_SIZE 0x37f8**

Bit(s)	R/W	Default	Description
30:29	R/W	0	reg_rst : unsigned , default = 0
28:16	R/W	0	hsizem1 : unsigned , default = 0x2cf
14	R/W	0	reg_reset : unsigned , default = 0
13	R/W	0	little_endian : unsigned , default = 0
12:0	R/W	0	vsizem1 : unsigned , default = 0x1df

### 9.2.3.5 DI\_RMEM\_IF0 Registers

Table 9-328 DI\_IF0\_GEN\_REG 0x2030

Bit(s)	R/W	Default	Description
31	R/W	0	ENABLE_FREE_CLK. 0: Gated clock for power saving 1: Free-running clock to drive logic
30	R/W	0	SW_RESET: Write 1 to this bit to generate a pulse to reset everything except registers.
29	R/W	0	RESET_ON_GO_FIELD: Define whether to reset state machines on go_field pulse. 0: No reset on go_field 1: go_field reset everything except registers
28	R/W	0	URGENT_CHROMA: Set urgent level for chroma fifo request from DDR. 0: Non urgent 1: Urgent
27	R/W	0	URGENT_LUMA: Set urgent level for luma fifo request from DDR. 0: Non urgent 1: Urgent
26	R/W	0	Chroma_end_at_last_line: For chroma line, similar to luma_end_at_last_line, as below. Not used if data are stored together in one canvas.
25	R/W	0	Luma_end_at_last_line: Control whether continue outputting luma line past last line. 0: Repeat the last line or dummy pixels, after past the last line 1: Stop outputting data, once past the last line.
24-19	R/W	4	Hold_lines: After go_field, the number of lines to hold before the module is enabled.
18	R/W	0	LAST_LINE: This bit controls whether we simply repeat the last line or we push dummy pixels. '1' tells the state-machines to repeat the last line using the dummy pixels defined in the register below. '0' indicates that the state-machine should re-read the last line of real data.
17	R	0	Busy status of the state-machines. '1' = busy, '0' = idle
16	R/W	0	DEMUX_MODE: 0 = 4:2:2, 1 = RGB (24-bit). This value is used to control the demuxing logic when the picture is stored together. When a picture is stored together, the data is read into a single FIFO (the Y FIFO) and must be demultiplexed into the "drain" outputs. In the case of 4:2:2 the data is assumed to be stored in memory in 16-bit chunks: <YCb><YCr><YCb><YCr>, the Y, Cb and Cr 8-bit values are pulled from the single Y-FIFO and sent out in pairs. This value is only valid when the picture is stored together. If the picture is separated into different canvases, then this bit field is ignored.
15-14	R/W	0	BYTES_PER_PIXEL: This value is used to determine how many bytes are associated with each pixel. 0: This value should be used if the image is stored separately (e.g. RGB or Y, Cb, Cr). 1: This value should be used if the data is 4:2:2 data stored together. In this case each pixel, YCb or YCr, is 16-bits (two bytes). 2: This value should be used if the RGB (24-bit) data is stored together. 3: reserved for future use (alpha RGB).
13-12	R/W	0	DDR_BURST_SIZE_CR: This value is used to control the DDR burst request size for the Cr FIFO. 0: Maximum burst = 24 64-bit values 1: Maximum burst = 32 64-bit values 2: Maximum burst = 48 64-bit values 3: Maximum burst = 64 64-bit values
11-10	R/W	0	DDR_BURST_SIZE_CB: This value is used to control the DDR burst request size for the Cb FIFO. 0: Maximum burst = 24 64-bit values 1: Maximum burst = 32 64-bit values 2: Maximum burst = 48 64-bit values 3: Maximum burst = 64 64-bit values
9-8	R/W	0	DDR_BURST_SIZE_Y: This value is used to control the DDR burst request size for the Y FIFO. 0: Maximum burst = 24 64-bit values 1: Maximum burst = 32 64-bit values 2: Maximum burst = 48 64-bit values 3: Maximum burst = 64 64-bit values

Bit(s)	R/W	Default	Description
7	R/W	0	MANUAL_START_FRAME: non-latching bit that can be used to simulate the go_field signal for simulation.
6	R/W	0	CHRO_RPT_LASTL_CTRL: This bit controls whether to allow VPP's chroma-repeat request.
5	R/W	0	Unused
4	R/W	0	LITTLE_ENDIAN: This bit defines the endianness of the memory data .
3	R/W	0	Chroma_hz_avg: For chroma line output control, similar to luma_hz_avg, as below. Not used if data are stored together in one canvas.
2	R/W	0	Luma_hz_avg: Enable output half amount of data per line to save bandwidth. 0: Output every pixel per line 1: Output half line, each data averaged between every 2 pixels Note: For 4:2:2 mode data stored together in one canvas, only do averaging over luma data.
1	R/W	0	SEPARATE_EN: Set this bit to 1 if the image is in separate canvas locations.
0	R/W	0	ENABLE: This bit is set to 1 to enable the FIFOs and other logic. This bit can be set to 0 to cleanup and put the logic into an IDLE state.

Table 9-329 DI\_IF0\_CANVAS0 – Picture 0 0x2031

Bit(s)	R/W	Default	Description
31-24	R/W	0	unused
23-16	R/W	0	CANVAS0_ADDR2: Canvas table address for picture 0 for component 2 (Cr FIFO). This value is ignored when the picture is stored together
15-8	R/W	0	CANVAS0_ADDR1: Canvas table address for picture 0 for component 1 (Cb FIFO). This value is ignored when the picture is stored together
7-0	R/W	0	CANVAS0_ADDR0: Canvas table address for picture 0 for component 0 (Y FIFO).

Table 9-330 DI\_IF0\_LUMA\_X0 – Picture 0 0x2032

Bit(s)	R/W	Default	Description
31	R/W	0	Unused
30-16	R/W	0	LUMA_X_END0: Picture 0, luma X end value
15	R/W	0	Unused
14-0	R/W	0	LUMA_X_START0: Picture 0, luma X start value

Table 9-331 DI\_IF0\_LUMA\_Y0 – Picture 0 0x2033

Bit(s)	R/W	Default	Description
31-29	R/W	0	Unused
28-16	R/W	0	LUMA_Y_END0: Picture 0, luma Y end value
15-13	R/W	0	Unused
12-0	R/W	0	LUMA_Y_START0: Picture 0, luma Y start value

**Table 9-332 DI\_IF0\_CHROMA\_X0 – Picture 0 0x2034**

Bit(s)	R/W	Default	Description
31	R/W	0	Unused
30-16	R/W	0	CHROMA_X_END0: Picture 0, chroma X end value. This value is only used when the picture is not stored together.
15	R/W	0	Unused
14-0	R/W	0	CHROMA_X_START0: Picture 0, chroma X start value. This value is only used when the picture is not stored together.

**Table 9-333 DI\_IF0\_CHROMA\_Y0 – Picture 0 0x2035**

Bit(s)	R/W	Default	Description
31-29	R/W	0	Unused
28-16	R/W	0	CHROMA_Y_END0: Picture 0, chroma Y end value. This value is only used when the picture is not stored together.
15-13	R/W	0	Unused
12-0	R/W	0	CHROMA_Y_START0: Picture 0, chroma Y start value. This value is only used when the picture is not stored together.

**Table 9-334 DI\_IF0\_REPEAT\_LOOP – Pictures 0 and 1 0x2036**

Bit(s)	R/W	Default	Description
31-24	R/W	0	CHROMA_RPT_LOOP1: Repeat loop for Picture 1. Bits[6:4] = start loop pointer, bits [2:0] = end loop pointer. Bits [7] and [3] are ignored.
23-16	R/W	0	LUMA_RPT_LOOP1: Repeat loop for Picture 1. Bits[6:4] = start loop pointer, bits [2:0] = end loop pointer. Bits [7] and [3] are ignored.
15-8	R/W	0	CHROMA_RPT_LOOP0: Repeat loop for Picture 0. Bits[6:4] = start loop pointer, bits [2:0] = end loop pointer. Bits [7] and [3] are ignored.
7-0	R/W	0	LUMA_RPT_LOOP0: Repeat loop for Picture 0. Bits[6:4] = start loop pointer, bits [2:0] = end loop pointer. Bits [7] and [3] are ignored.

**Table 9-335 DI\_IF0\_LUMA0\_RPT\_PAT – Picture 0 LUMA repeat pattern 0x2037**

Bit(s)	R/W	Default	Description
31-0	R/W	0	Luma repeat/skip pattern for picture 0

Bits	Pattern Index	Pattern description
31-28	7	<p>Repeat/skip pattern:            Bit[3] = 0 indicates repeat.            Bit[3] = 1 indicates either skip, or output this line and then skip. How to interpret this bit depends on the value of the previous pattern's Bit[3]. If previous Bit[3]=0, then skip; If previous Bit[3]=1, then output this line and then skip.            Bits[2:0] indicate the skip / repeat count.</p> <p>Blow is an example of consecutive patterns, the start line is line 0:            {0010} Repeat this line (line 0) two more times for a total of three line reads. Proceed to next line (line 1).            {0000} Don't repeat this line (line 1). This line will be read just once. Proceed to next line (line 2).            {1000} Skip one line (line 2) to get to the next line (line 3). The skip implies that the next line (line 3) should be read at least once.            {1011} Read this line (line 3) once, and then skip the next four lines to get to the next line (line 8). The skip implies that the next line (line 8) should be read at least once.            {0100} Repeat this line (line 8) four more times for a total of five line read. Proceed to next line (line 9).            {1001} Skip two lines to get to the next line (line 11). The skip implies that the next line (line 11) should be read at least once.</p>
27-24	6	See pattern definition above.
23-20	5	See pattern definition above.
19-16	4	See pattern definition above.
15-12	3	See pattern definition above.
11-8	2	See pattern definition above.
7-4	1	See pattern definition above.
3-0	0	See pattern definition above.

**Table 9-336 DI\_IF0\_CHROMA0\_RPT\_PAT – Picture 0 CHROMA repeat pattern 0x2038**

Bit(s)	R/W	Default	Description
31-0	R/W	0	Chroma repeat/skip pattern for picture 0. See picture 0 luma pattern for description. This value is only used when the picture is not stored together.

**Table 9-337 DI\_IF0\_DUMMY\_PIXEL 0x2039**

Bit(s)	R/W	Default	Description
31-24	R/W	0	Y or R dummy pixel value
23-16	R/W	0	Cb or G dummy pixel value
15-8	R/W	0	Cr or B dummy pixel value
7-0	R/W	0	unused

**Table 9-338 DI\_IF0\_LUMA\_FIFO\_SIZE 0x203A**

Bit(s)	R/W	Default	Description
8-0	W/R	128	fifo size

**Table 9-339 DI\_IF0\_RANGE\_MAP\_Y 0x203B**

Bit(s)	R/W	Default	Description
31-23	W/R	0	din offset
22-15	W/R	0	range map coef
13-10	W/R	0	range map din offset mult
9-1	W/R	0	dout offset
0	W/R	0	range map enable

**Table 9-340 DI\_IF0\_RANGE\_MAP\_CB 0x203C**

Bit(s)	R/W	Default	Description
31-23	W/R	0	din offset
22-15	W/R	0	range map coef
13-10	W/R	0	range map din offset mult
9-1	W/R	0	dout offset
0	W/R	0	range map enable

**Table 9-341 DI\_IF0\_RANGE\_MAP\_CR 0x203D**

Bit(s)	R/W	Default	Description
31-23	W/R	0	din offset
22-15	W/R	0	range map coef
13-10	W/R	0	range map din offset mult
9-1	W/R	0	dout offset
0	W/R	0	range map enable

$Y[n] = \text{clip}(\text{Round}((Y[n] + \text{DIN\_OFFSET}) * \text{RANGE\_MAP\_COEF}) / (1 \ll \text{RANGE\_MAP\_SR}) + \text{DOUT\_OFFSET});$

To perform VC-1 range reduction, set the following:

$\text{DIN\_OFFSET} = 0x180 = -128;$

$\text{RANGE\_MAP\_COEF} = \text{RANGE\_MAPY} + 9$

$\text{RANGE\_MAP\_SR} = 3$

$\text{DOUT\_OFFSET} = 0x080 = 128$

To get the equivalent function:

$Y[n] = \text{clip}(((Y[n]-128) * (\text{RANGE\_MAPY} + 9) + 4) \gg 3) + 128);$



**Table 9-342 Output data range conversion function**

Bit(s)	R/W	Default	Description
31-23	R/W	0	DIN_OFFSET
22-15	R/W	0	RANGE_MAP_COEF
14	R/W	0	unused
13-10	R/W	0	RANGE_MAP_SR
9-1	R/W	0	DOUT_OFFSET
0	R/W	0	RANGE_MAP_EN

**Table 9-343 DI\_IF0\_GEN\_REG2 0x203E**

Bit(s)	R/W	Default	Description
31-30	R/W	0	unused
29	R/W	0	chroma line read sel
28	R/W	0	luma line read sel
25:24	R/W	0	shift_pat_cr
17:16	R/W	0	shift_pat_cb
9-8	R/W	0	shift_pat_y
6	R/W	0	hold_line[6]
3	R/W	0	y_rev
2	R/W	0	x_rev
1-0	R/W	0	COLOR_MAP: Define color map for NV12 or NV21 mode. Only applicable when VD1_IF0_GEN_REG.SEPARATE_EN = 1. 0: NOT NV12 or NV21; 1: NV12 (CbCr); 2: NV21 (CrCb).

**Table 9-344 DI\_IF0\_FMT\_CTRL 0x203F**

Bit(s)	R/W	Default	Description
31	R/W	0	gate_clk_en. 0=No clock gating, free-running; 1=Enable clock gating for power saving.
30	R/W	0	soft_rst. If true, reset formatters.
29	R/W	0	unused
28	R/W	0	if true, horizontal formatter use repeating to generate pixel, otherwise use bilinear interpolation
27-24	R/W	0	horizontal formatter initial phase
23	R/W	0	horizontal formatter repeat pixel 0 enable
22-21	R/W	0	horizontal Y/C ratio, 00: 1:1, 01: 2:1, 10: 4:1
20	R/W	0	horizontal formatter enable
19	R/W	0	if true, always use phase0 while vertical formatter, meaning always repeat data, no interpolation
18	R/W	0	if true, disable vertical formatter chroma repeat last line

Bit(s)	R/W	Default	Description
17	R/W	0	vertical formatter dont need repeat line on phase0, 1: enable, 0: disable
16	R/W	0	vertical formatter repeat line 0 enable
15-12	R/W	0	vertical formatter skip line num at the beginning
11-8	R/W	0	vertical formatter initial phase
7-1	R/W	0	vertical formatter phase step (3.4)
0	R/W	0	vertical formatter enable

Table 9-345 DI\_IF0\_FMT\_W 0x2040

Bit(s)	R/W	Default	Description
27-16	R/W	0	horizontal formatter width
11-0	R/W	0	vertical formatter width

### 9.2.3.6 VIUB Registers (slow clock)

DI\_IF2\_GEN\_REG 0x2010

Same as DI\_IF1\_GEN\_REG

DI\_IF2\_CANVAS0 0x2011

Same as DI\_IF1\_CANVAS0

DI\_IF2\_LUMA\_X0 0x2012

Same as DI\_IF1\_LUMA\_X0

DI\_IF2\_LUMA\_Y0 0x2013

Same as DI\_IF1\_LUMA\_Y0

DI\_IF2\_CHROMA\_X0 0x2014

Same as DI\_IF1\_CHROMA\_X0

DI\_IF2\_CHROMA\_Y0 0x2015

Same as DI\_IF1\_CHROMA\_Y0

DI\_IF2\_RPT\_LOOP 0x2016

Same as DI\_IF1\_RPT\_LOOP

DI\_IF2\_LUMA0\_RPT\_PAT 0x2017

Same as DI\_IF1\_LUMA0\_RPT\_PAT

DI\_IF2\_CHROMA0\_RPT\_PAT 0x2018

Same as DI\_IF1\_CHROMA0\_RPT\_PAT

DI\_IF2\_DUMMY\_PIXEL 0x2019

Same as DI\_IF1\_DUMMY\_PIXEL

DI\_IF2\_LUMA\_FIFO\_SIZE 0x201a

Same as DI\_IF1\_LUMA\_FIFO\_SIZE

DI\_IF2\_RANGE\_MAP\_Y 0x201b

Same as DI\_IF1\_RANGE\_MAP\_Y

DI\_IF2\_RANGE\_MAP\_CB 0x201c

Same as DI\_IF1\_RANGE\_MAP\_CB

DI\_IF2\_RANGE\_MAP\_CR 0x201d

Same as DI\_IF1\_RANGE\_MAP\_CR

**DI\_IF2\_GEN\_REG2** 0x201e

Same as DI\_IF1\_GEN\_REG2

DI\_IF2\_FMT\_CTRL 0x201f

Same as DI\_IF1\_FMT\_CTRL

DI\_IF2\_FMT\_W 0x2020

Same as DI\_IF1\_FMT\_W

DI\_IF2\_URGENT\_CTRL 0x2021

Same as DI\_IF1\_URGENT\_CTRL

**Table 9-346 DI\_IF0\_GEN\_REG3 0x2042**

Bit(s)	R/W	Default	Description
11-10	R/W	0	cntl_dbg_mode
9-8	R/W	0	cntl_bits_mode : 0->8bit 1->10bit 422 2->10bit 444
6-4	R/W	3	cntl_blk_len
2-1	R/W	1	cntl_burst_len
0	R/W	1	cntl_64bit_rev

**Table 9-347 DI\_IF1\_GEN\_REG3 0x20a7**

Bit(s)	R/W	Default	Description
11-10	R/W	0	cntl_dbg_mode
9-8	R/W	0	cntl_bits_mode : 0->8bit 1->10bit 422 2->10bit 444
6-4	R/W	3	cntl_blk_len
2-1	R/W	1	cntl_burst_len
0	R/W	1	cntl_64bit_rev

**Table 9-348 DI\_IF2\_GEN\_REG3 0x2022**

Bit(s)	R/W	Default	Description
11-10	R/W	0	cntl_dbg_mode
9-8	R/W	0	cntl_bits_mode : 0->8bit 1->10bit 422 2->10bit 444
6-4	R/W	3	cntl_blk_len

Bit(s)	R/W	Default	Description
2-1	R/W	1	cntl_burst_len
0	R/W	1	cntl_64bit_rev

Table 9-349 DI\_INP\_GEN\_REG3 0x20a8

Bit(s)	R/W	Default	Description
11-10	R/W	0	cntl_dbg_mode
9-8	R/W	0	cntl_bits_mode : 0->8bit 1->10bit 422 2->10bit 444
6-4	R/W	3	cntl_blk_len
2-1	R/W	1	cntl_burst_len
0	R/W	1	cntl_64bit_rev

Table 9-350 DI\_MEM\_GEN\_REG3 0x20a9

Bit(s)	R/W	Default	Description
11-10	R/W	0	cntl_dbg_mode
9-8	R/W	0	cntl_bits_mode : 0->8bit 1->10bit 422 2->10bit 444
6-4	R/W	3	cntl_blk_len
2-1	R/W	1	cntl_burst_len
0	R/W	1	cntl_64bit_rev

Table 9-351 DI\_CHAN2\_GEN\_REG3 0x20aa

Bit(s)	R/W	Default	Description
11-10	R/W	0	cntl_dbg_mode
9-8	R/W	0	cntl_bits_mode : 0->8bit 1->10bit 422 2->10bit 444
6-4	R/W	3	cntl_blk_len
2-1	R/W	1	cntl_burst_len
0	R/W	1	cntl_64bit_rev

### 9.2.3.7 De-Interlace Registers

#### De-Interlace mif Registers

Table 9-352 DI\_IF1\_GEN\_REG 0x17E8

Bit(s)	R/W	Default	Description
31	W/R	0	enable free clk
30	W/R	0	sw reset : pulse bit
29	W/R	0	reset on go field

Bit(s)	R/W	Default	Description
28	W/R	0	urgent chroma
27	W/R	0	urgent luma
26	W/R	0	chroma end at last line : 0 = read last line or push dummy after last line; 1 = stop read after last line
25	W/R	0	luma end at last line : 0 = read last line or push dummy after last line; 1 = stop read after last line
24-19	W/R	4	hold line[5:0], see GEN_REG2[6]
18	W/R	1	last line mode: 0 = read last line; 1 = push fixed value
16	W/R	0	demux mode: 0 = 4:2:2 demux; 1 = RGB demuxing from a single FIFO
15-14	W/R	0	bytes per pixel : 0= 1byte per pixel; 1 = 2 bytes per pixel; 2 = 3bytes per pixel
13-12	W/R	0	burst size cr: 0 = 24x64; 1 = 32x64; 2 = 48x64; 3 = 64x64
11-10	W/R	0	burst size cb: 0 = 24x64; 1 = 32x64; 2 = 48x64; 3 = 64x64
9-8	W/R	0	burst size y: 0 = 24x64; 1 = 32x64; 2 = 48x64; 3 = 64x64
7	W/R	0	start frame manual : pulse bit
6	W/R	0	chroma repeat last1
5	W/R	0	Reserved
4	W/R	0	little endian: 0=Pixels are big-endian in memory; 1=Pixel are little-endian in memory
3	W/R	0	chroma hz avg: 0= output pixel by pixel per line; 1= output half line ,average between every 2 pixels
2	W/R	0	luma_hz_avg: 0= output pixel by pixel per line; 1= output half line ,average between every 2 pixels
1	W/R	0	separate_en: Set to 1 to use 3 separate FIFO's
0	W/R	0	enable

Table 9-353 DI\_IF1\_GEN\_REG2 0x1790

Bit(s)	R/W	Default	Description
31-30	R/W	0	unused
29	R/W	0	chroma line read sel
28	R/W	0	luma line read sel
25-14	W/R	0	shift pat cr
17-16	W/R	0	shift pat cb
9-8	W/R	0	shift pat y
6	W/R	0	hold_lines[6]
3	W/R	0	y_rev: X read direction: 0=default ,normal read; 1=reverse read
2	W/R	0	x_rev: Y read direction: 0=default ,normal read; 1=reverse read
1-0	W/R	0	color map: 0=default color map as defined by "bytes per pixel"; 1=NV12(CbCr); 2=NV21(CrCb)

**Table 9-354 DI\_IF1\_CANVAS0 0x17E9**

Bit(s)	R/W	Default	Description
31	W/R	0	canvas addr syncen
23-16	W/R	0	canvas addr2
15-8	W/R	0	canvas addr1
7-0	W/R	0	canvas addr0

**Table 9-355 DI\_IF1\_LUMA\_X0 0x17EA**

Bit(s)	R/W	Default	Description
30-16	W/R	0	luma_x_end
14-0	W/R	0	luma_x_start

**Table 9-356 DI\_IF1\_LUMA\_Y0 0x17EB**

Bit(s)	R/W	Default	Description
28-16	W/R	0	luma_y_end
12-0	W/R	0	luma_y_start

**Table 9-357 DI\_IF1\_CHROMA\_X0 0x17EC**

Bit(s)	R/W	Default	Description
30-16	W/R	0	chroma_x_end
14-0	W/R	0	chroma_x_start

**Table 9-358 DI\_IF1\_CHROMA\_Y0 0x17ED**

Bit(s)	R/W	Default	Description
28-16	W/R	0	chroma_y_end
12-0	W/R	0	chroma_y_start

**Table 9-359 DI\_IF1\_RPT\_LOOP 0x17EE**

Bit(s)	R/W	Default	Description
15-8	W/R	0	chroma repeat loop
7-0	W/R	0	luma repeat loop

**Table 9-360 DI\_IF1\_LUMA0\_RPT\_PAT 0x17EF**

Bit(s)	R/W	Default	Description
31-0	W/R	0	luma repeat pattern

**Table 9-361 DI\_IF1\_CHROMA0\_RPT\_PAT 0x17F0**

Bit(s)	R/W	Default	Description
7-0	W/R	0	chroma repeat loop

**Table 9-362 DI\_IF1\_DUMMY\_PIXEL 0x17F1**

Bit(s)	R/W	Default	Description
31-0	W/R	0x8080-00	dummy pixel

**Table 9-363 DI\_IF1\_LUMA\_FIFO\_SIZE 0x17F2**

Bit(s)	R/W	Default	Description
8-0	W/R	128	fifo size

**Table 9-364 DI\_IF1\_RANGE\_MAP\_Y 0x17FC**

Bit(s)	R/W	Default	Description
31-23	W/R	0	din offset
22-15	W/R	0	range map coef
13-10	W/R	0	range map din offset mult
9-1	W/R	0	dout offset
0	W/R	0	range map enable

**Table 9-365 DI\_IF1\_RANGE\_MAP\_CB 0x17FD**

Bit(s)	R/W	Default	Description
31-23	W/R	0	din offset
22-15	W/R	0	range map coef
13-10	W/R	0	range map din offset mult
9-1	W/R	0	dout offset
0	W/R	0	range map enable

**Table 9-366 DI\_IF1\_RANGE\_MAP\_CR 0x17FE**

Bit(s)	R/W	Default	Description
31-23	W/R	0	din offset
22-15	W/R	0	range map coef
13-10	W/R	0	range map din offset mult
9-1	W/R	0	dout offset
0	W/R	0	range map enable

**Table 9-367 DI\_IF1\_URGENT\_CTRL 0x17A3**

Bit(s)	R/W	Default	Description
13-16	W/R	0	urgent_ctrl_luma: bit 15: auto_urgent_en bit 14: urgent_wr bit 7-4: up_threshold bit 3-0: down_threshold
15-0	W/R	0	urgent_ctrl_chroma: bit 15: auto_urgent_en bit 14: urgent_wr bit 7-4: up_threshold bit 3-0: down_threshold

**Table 9-368 DI\_IF1\_FMT\_CTRL 0x17F3**

Bit(s)	R/W	Default	Description
31	R/W	0	gate_clk_en. 0=No clock gating, free-running; 1=Enable clock gating for power saving.
30	R/W	0	soft_rst. If true, reset formatters.
29	R/W	0	unused
28	R/W	0	if true, horizontal formatter use repeating to generate pixel, otherwise use bilinear interpolation
27-24	R/W	0	horizontal formatter initial phase
23	R/W	0	horizontal formatter repeat pixel 0 enable
22-21	R/W	0	horizontal Y/C ratio, 00: 1:1, 01: 2:1, 10: 4:1
20	R/W	0	horizontal formatter enable
19	R/W	0	if true, always use phase0 while vertical formatter, meaning always repeat data, no interpolation
18	R/W	0	if true, disable vertical formatter chroma repeat last line
17	R/W	0	vertical formatter dont need repeat line on phase0, 1: enable, 0: disable
16	R/W	0	vertical formatter repeat line 0 enable
15-12	R/W	0	vertical formatter skip line num at the beginning
11-8	R/W	0	vertical formatter initial phase
7-1	R/W	0	vertical formatter phase step (3.4)
0	R/W	0	vertical formatter enable

**Table 9-369 DI\_IF1\_FMT\_W 0x17F4**

Bit(s)	R/W	Default	Description
27-16	R/W	0	horizontal formatter width
12-0	R/W	0	vertical formatter width

**Table 9-370 DI\_INP\_GEN\_REG 0x17CE**

Bit(s)	R/W	Default	Description
31	W/R	0	enable free clk
30	W/R	0	sw reset : pulse bit



Bit(s)	R/W	Default	Description
29	W/R	0	reset on go field
28	W/R	0	urgent chroma
27	W/R	0	urgent luma
26	W/R	0	chroma end at last line : 0 = read last line or push dummy after last line; 1 = stop read after last line
25	W/R	0	luma end at last line : 0 = read last line or push dummy after last line; 1 = stop read after last line
24-19	W/R	4	hold line[5:0], see GEN_REG2[6]
18	W/R	1	last line mode: 0 = read last line; 1 = push fixed value
16	W/R	0	demux mode: 0 = 4:2:2 demux; 1 = RGB demuxing from a single FIFO
15-14	W/R	0	bytes per pixel : 0= 1byte per pixel; 1 = 2 bytes per pixel; 2 = 3bytes per pixel
13-12	W/R	0	burst size cr: 0 = 24x64; 1 = 32x64; 2 = 48x64; 3 = 64x64
11-10	W/R	0	burst size cb: 0 = 24x64; 1 = 32x64; 2 = 48x64; 3 = 64x64
9-8	W/R	0	burst size y: 0 = 24x64; 1 = 32x64; 2 = 48x64; 3 = 64x64
7	W/R	0	start frame manual : pulse bit
6	W/R	0	chroma repeat last1
5	W/R	0	Reserved
4	W/R	0	little endian: 0=Pixels are big-endian in memory; 1=Pixel are little-endian in memory
3	W/R	0	chroma hz avg: 0= output pixel by pixel per line; 1= output half line ,average between every 2 pixels
2	W/R	0	luma_hz_avg: 0= output pixel by pixel per line; 1= output half line ,average between every 2 pixels
1	W/R	0	separate_en: Set to 1 to use 3 separate FIFO's
0	W/R	0	enable

Table 9-371 DI\_INP\_GEN\_REG2 0x1791

Bit(s)	R/W	Default	Description
29	W/R	0	chroma line read sel
28	W/R	0	luma line read sel
25-14	W/R	0	shift pat cr
17-16	W/R	0	shift pat cb
9-8	W/R	0	shift pat y
6	W/R	0	hold_lines[6]
3	W/R	0	y_rev: X read direction: 0=default ,normal read; 1=reverse read
2	W/R	0	x_rev: Y read direction: 0=default ,normal read; 1=reverse read
1-0	W/R	0	color map: 0=default color map as defined by "bytes per pixel"; 1=Nv12(CbCr); 2=Nv21(CrCb)

**Table 9-372 DI\_INP\_CANVAS0 0x17CF**

Bit(s)	R/W	Default	Description
31	W/R	0	canvas addr syncen
23-16	W/R	0	canvas addr2
15-8	W/R	0	canvas addr1
7-0	W/R	0	canvas addr0

**Table 9-373 DI\_INP\_LUMA\_X0 0x17D0**

Bit(s)	R/W	Default	Description
30-16	W/R	0	luma_x_end
14-0	W/R	0	luma_x_start

**Table 9-374 DI\_INP\_LUMA\_Y0 0x17D1**

Bit(s)	R/W	Default	Description
28-16	W/R	0	luma_y_end
12-0	W/R	0	luma_y_start

**Table 9-375 DI\_INP\_CHROMA\_X0 0x17D2**

Bit(s)	R/W	Default	Description
30-16	W/R	0	chroma_x_end
14-0	W/R	0	chroma_x_start

**Table 9-376 DI\_INP\_CHROMA\_Y0 0x17D3**

Bit(s)	R/W	Default	Description
28-16	W/R	0	chroma_y_end
12-0	W/R	0	chroma_y_start

**Table 9-377 DI\_INP\_RPT\_LOOP 0x17D4**

Bit(s)	R/W	Default	Description
15-8	W/R	0	chroma repeat loop
7-0	W/R	0	luma repeat loop

**Table 9-378 DI\_INP\_LUMA0\_RPT\_PAT 0x17D5**

Bit(s)	R/W	Default	Description
31-0	W/R	0	luma repeat pattern

**Table 9-379 DI\_INP\_CHROMA0\_RPT\_PAT 0x17D6**

Bit(s)	R/W	Default	Description
7-0	W/R	0	chroma repeat loop

**Table 9-380 DI\_INP\_DUMMY\_PIXEL 0x17D7**

Bit(s)	R/W	Default	Description
31-0	W/R	0x8080-00	dummy pixel

**Table 9-381 DI\_INP\_LUMA\_FIFO\_SIZE 0x17D8**

Bit(s)	R/W	Default	Description
8-0	W/R	128	fifo size

**Table 9-382 DI\_INP\_RANGE\_MAP\_Y 0x17BA**

Bit(s)	R/W	Default	Description
31-23	W/R	0	din offset
22-15	W/R	0	range map coef
13-10	W/R	0	range map din offset mult
9-1	W/R	0	dout offset
0	W/R	0	range map enable

**Table 9-383 DI\_INP\_RANGE\_MAP\_CB 0x17BB**

Bit(s)	R/W	Default	Description
31-23	W/R	0	din offset
22-15	W/R	0	range map coef
13-10	W/R	0	range map din offset mult
9-1	W/R	0	dout offset
0	W/R	0	range map enable

**Table 9-384 DI\_INP\_RANGE\_MAP\_CR 0x17BC**

Bit(s)	R/W	Default	Description
31-23	W/R	0	din offset
22-15	W/R	0	range map coef
13-10	W/R	0	range map din offset mult
9-1	W/R	0	dout offset
0	W/R	0	range map enable

**Table 9-385 DI\_INP\_URGENT\_CTRL 0x17A4**

Bit(s)	R/W	Default	Description
13-16	W/R	0	urgent_ctrl_luma: bit 15: auto_urgent_en bit 14: urgent_wr bit 7-4: up_threshold bit 3-0: down_threshold
15-0	W/R	0	urgent_ctrl_chroma: bit 15: auto_urgent_en bit 14: urgent_wr bit 7-4: up_threshold bit 3-0: down_threshold

**Table 9-386 DI\_INP\_FMT\_CTRL 0x17D9**

Bit(s)	R/W	Default	Description
31	R/W	0	gate_clk_en. 0=No clock gating, free-running; 1=Enable clock gating for power saving.
30	R/W	0	soft_rst. If true, reset formatters.
29	R/W	0	unused
28	R/W	0	if true, horizontal formatter use repeating to generate pixel, otherwise use bilinear interpolation
27-24	R/W	0	horizontal formatter initial phase
23	R/W	0	horizontal formatter repeat pixel 0 enable
22-21	R/W	0	horizontal Y/C ratio, 00: 1:1, 01: 2:1, 10: 4:1
20	R/W	0	horizontal formatter enable
19	R/W	0	if true, always use phase0 while vertical formatter, meaning always repeat data, no interpolation
18	R/W	0	if true, disable vertical formatter chroma repeat last line
17	R/W	0	vertical formatter dont need repeat line on phase0, 1: enable, 0: disable
16	R/W	0	vertical formatter repeat line 0 enable
15-12	R/W	0	vertical formatter skip line num at the beginning
11-8	R/W	0	vertical formatter initial phase
7-1	R/W	0	vertical formatter phase step (3.4)
0	R/W	0	vertical formatter enable

**Table 9-387 DI\_INP\_FMT\_W 0x17DA**

Bit(s)	R/W	Default	Description
27-16	R/W	0	horizontal formatter width
12-0	R/W	0	vertical formatter width

**Table 9-388 DI\_MEM\_GEN\_REG 0x17DB**

Bit(s)	R/W	Default	Description
31	W/R	0	enable free clk
30	W/R	0	sw reset : pulse bit

Bit(s)	R/W	Default	Description
29	W/R	0	reset on go field
28	W/R	0	urgent chroma
27	W/R	0	urgent luma
26	W/R	0	chroma end at last line : 0 = read last line or push dummy after last line; 1 = stop read after last line
25	W/R	0	luma end at last line : 0 = read last line or push dummy after last line; 1 = stop read after last line
24-19	W/R	4	hold line[5:0], see GEN_REG2[6]
18	W/R	1	last line mode: 0 = read last line; 1 = push fixed value
16	W/R	0	demux mode: 0 = 4:2:2 demux; 1 = RGB demuxing from a single FIFO
15-14	W/R	0	bytes per pixel : 0= 1byte per pixel; 1 = 2 bytes per pixel; 2 = 3bytes per pixel
13-12	W/R	0	burst size cr: 0 = 24x64; 1 = 32x64; 2 = 48x64; 3 = 64x64
11-10	W/R	0	burst size cb: 0 = 24x64; 1 = 32x64; 2 = 48x64; 3 = 64x64
9-8	W/R	0	burst size y: 0 = 24x64; 1 = 32x64; 2 = 48x64; 3 = 64x64
7	W/R	0	start frame manual : pulse bit
6	W/R	0	chroma repeat last1
5	W/R	0	Reserved
4	W/R	0	little endian: 0=Pixels are big-endian in memory; 1=Pixel are little-endian in memory
3	W/R	0	chroma hz avg: 0= output pixel by pixel per line; 1= output half line ,average between every 2 pixels
2	W/R	0	luma_hz_avg: 0= output pixel by pixel per line; 1= output half line ,average between every 2 pixels
1	W/R	0	separate_en: Set to 1 to use 3 separate FIFO's
0	W/R	0	enable

Table 9-389 DI\_MEM\_GEN\_REG2 0x1792

Bit(s)	R/W	Default	Description
25-14	W/R	0	shift pat cr
17-16	W/R	0	shift pat cb
9-8	W/R	0	shift pat y
6	W/R	0	hold_lines[6]
3	W/R	0	y_rev: X read direction: 0=default ,normal read; 1=reverse read
2	W/R	0	x_rev: Y read direction: 0=default ,normal read; 1=reverse read
1-0	W/R	0	color map: 0=default color map as defined by "bytes per pixel"; 1=Nv12(CbCr); 2=Nv21(CrCb)

**Table 9-390 DI\_MEM\_CANVAS0 0x17DC**

Bit(s)	R/W	Default	Description
31	W/R	0	canvas addr syncen
23-16	W/R	0	canvas addr2
15-8	W/R	0	canvas addr1
7-0	W/R	0	canvas addr0

**Table 9-391 DI\_MEM\_LUMA\_X0 0x17DD**

Bit(s)	R/W	Default	Description
30-16	W/R	0	luma_x_end
14-0	W/R	0	luma_x_start

**Table 9-392 DI\_MEM\_LUMA\_Y0 0x17DE**

Bit(s)	R/W	Default	Description
28-16	W/R	0	luma_y_end
12-0	W/R	0	luma_y_start

**Table 9-393 DI\_MEM\_CHROMA\_X0 0x17DF**

Bit(s)	R/W	Default	Description
30-16	W/R	0	chroma_x_end
14-0	W/R	0	chroma_x_start

**Table 9-394 DI\_MEM\_CHROMA\_Y0 0x17E0**

Bit(s)	R/W	Default	Description
28-16	W/R	0	chroma_y_end
12-0	W/R	0	chroma_y_start

**Table 9-395 DI\_MEM\_RPT\_LOOP 0x17E1**

Bit(s)	R/W	Default	Description
15-8	W/R	0	chroma repeat loop
7-0	W/R	0	luma repeat loop

**Table 9-396 DI\_MEM\_LUMA0\_RPT\_PAT 0x17E2**

Bit(s)	R/W	Default	Description
31-0	W/R	0	luma repeat pattern

**Table 9-397 DI\_MEM\_CHROMA0\_RPT\_PAT 0x17E3**

Bit(s)	R/W	Default	Description
7-0	W/R	0	chroma repeat loop

**Table 9-398 DI\_MEM\_DUMMY\_PIXEL 0x17E4**

Bit(s)	R/W	Default	Description
31-0	W/R	0x8080-00	dummy pixel

**Table 9-399 DI\_MEM\_LUMA\_FIFO\_SIZE 0x17E5**

Bit(s)	R/W	Default	Description
8-0	W/R	128	fifo size

**Table 9-400 DI\_MEM\_RANGE\_MAP\_Y 0x17BD**

Bit(s)	R/W	Default	Description
31-23	W/R	0	din offset
22-15	W/R	0	range map coef
13-10	W/R	0	range map din offset mult
9-1	W/R	0	dout offset
0	W/R	0	range map enable

**Table 9-401 DI\_MEM\_RANGE\_MAP\_CB 0x17BE**

Bit(s)	R/W	Default	Description
31-23	W/R	0	din offset
22-15	W/R	0	range map coef
13-10	W/R	0	range map din offset mult
9-1	W/R	0	dout offset
0	W/R	0	range map enable

**Table 9-402 DI\_MEM\_RANGE\_MAP\_CR 0x17BF**

Bit(s)	R/W	Default	Description
31-23	W/R	0	din offset
22-15	W/R	0	range map coef
13-10	W/R	0	range map din offset mult
9-1	W/R	0	dout offset
0	W/R	0	range map enable

**Table 9-403 DI\_MEM\_URGENT\_CTRL 0x17A5**

Bit(s)	R/W	Default	Description
13-16	W/R	0	urgent_ctrl_luma: bit 15: auto_urgent_en bit 14: urgent_wr bit 7-4: up_threshold bit 3-0: down_threshold
15-0	W/R	0	urgent_ctrl_chroma: bit 15: auto_urgent_en bit 14: urgent_wr bit 7-4: up_threshold bit 3-0: down_threshold

**Table 9-404 DI\_MEM\_FMT\_CTRL 0x17E6**

Bit(s)	R/W	Default	Description
31	R/W	0	gate_clk_en. 0=No clock gating, free-running; 1=Enable clock gating for power saving.
30	R/W	0	soft_rst. If true, reset formatters.
29	R/W	0	unused
28	R/W	0	if true, horizontal formatter use repeating to generate pixel, otherwise use bilinear interpolation
27-24	R/W	0	horizontal formatter initial phase
23	R/W	0	horizontal formatter repeat pixel 0 enable
22-21	R/W	0	horizontal Y/C ratio, 00: 1:1, 01: 2:1, 10: 4:1
20	R/W	0	horizontal formatter enable
19	R/W	0	if true, always use phase0 while vertical formatter, meaning always repeat data, no interpolation
18	R/W	0	if true, disable vertical formatter chroma repeat last line
17	R/W	0	vertical formatter dont need repeat line on phase0, 1: enable, 0: disable
16	R/W	0	vertical formatter repeat line 0 enable
15-12	R/W	0	vertical formatter skip line num at the beginning
11-8	R/W	0	vertical formatter initial phase
7-1	R/W	0	vertical formatter phase step (3.4)
0	R/W	0	vertical formatter enable

**Table 9-405 DI\_MEM\_FMT\_W 0x17E7**

Bit(s)	R/W	Default	Description
27-16	R/W	0	horizontal formatter width
12-0	R/W	0	vertical formatter width

**Table 9-406 DI\_CHAN2\_GEN\_REG 0x17F5**

Bit(s)	R/W	Default	Description
31	W/R	0	enable free clk
30	W/R	0	sw reset : pulse bit



Bit(s)	R/W	Default	Description
29	W/R	0	reset on go field
28	W/R	0	urgent chroma
27	W/R	0	urgent luma
26	W/R	0	chroma end at last line : 0 = read last line or push dummy after last line; 1 = stop read after last line
25	W/R	0	luma end at last line : 0 = read last line or push dummy after last line; 1 = stop read after last line
24-19	W/R	4	hold line[5:0], see GEN_REG2[6]
18	W/R	1	last line mode: 0 = read last line; 1 = push fixed value
16	W/R	0	demux mode: 0 = 4:2:2 demux; 1 = RGB demuxing from a single FIFO
15-14	W/R	0	bytes per pixel : 0= 1byte per pixel; 1 = 2 bytes per pixel; 2 = 3bytes per pixel
13-12	W/R	0	burst size cr: 0 = 24x64; 1 = 32x64; 2 = 48x64; 3 = 64x64
11-10	W/R	0	burst size cb: 0 = 24x64; 1 = 32x64; 2 = 48x64; 3 = 64x64
9-8	W/R	0	burst size y: 0 = 24x64; 1 = 32x64; 2 = 48x64; 3 = 64x64
7	W/R	0	start frame manual : pulse bit
6	W/R	0	chroma repeat last1
5	W/R	0	Reserved
4	W/R	0	little endian: 0=Pixels are big-endian in memory; 1=Pixel are little-endian in memory
3	W/R	0	chroma hz avg: 0= output pixel by pixel per line; 1= output half line ,average between every 2 pixels
2	W/R	0	luma_hz_avg: 0= output pixel by pixel per line; 1= output half line ,average between every 2 pixels
1	W/R	0	separate_en: Set to 1 to use 3 separate FIFO's
0	W/R	0	enable

Table 9-407 DI\_CHAN2\_GEN\_REG2 0x17B7

Bit(s)	R/W	Default	Description
25-14	W/R	0	shift pat cr
17-16	W/R	0	shift pat cb
9-8	W/R	0	shift pat y
6	W/R	0	hold_lines[6]
3	W/R	0	y_rev: X read direction: 0=default ,normal read; 1=reverse read
2	W/R	0	x_rev: Y read direction: 0=default ,normal read; 1=reverse read
1-0	W/R	0	color map: 0=default color map as defined by "bytes per pixel"; 1=Nv12(CbCr); 2=Nv21(CrCb)

**Table 9-408 DI\_CHAN2\_CANVAS0 0x17F6**

Bit(s)	R/W	Default	Description
31	W/R	0	canvas addr syncen
23-16	W/R	0	canvas addr2
15-8	W/R	0	canvas addr1
7-0	W/R	0	canvas addr0

**Table 9-409 DI\_CHAN2\_LUMA\_X0 0x17F7**

Bit(s)	R/W	Default	Description
30-16	W/R	0	luma_x_end
14-0	W/R	0	luma_x_start

**Table 9-410 DI\_CHAN2\_LUMA\_Y0 0x17F8**

Bit(s)	R/W	Default	Description
28-16	W/R	0	luma_y_end
12-0	W/R	0	luma_y_start

**Table 9-411 DI\_CHAN2\_CHROMA\_X0 0x17F9**

Bit(s)	R/W	Default	Description
30-16	W/R	0	chroma_x_end
14-0	W/R	0	chroma_x_start

**Table 9-412 DI\_CHAN2\_CHROMA\_Y0 0x17FA**

Bit(s)	R/W	Default	Description
28-16	W/R	0	chroma_y_end
12-0	W/R	0	chroma_y_start

**Table 9-413 DI\_CHAN2\_RPT\_LOOP 0x17FB**

Bit(s)	R/W	Default	Description
15-8	W/R	0	chroma repeat loop
7-0	W/R	0	luma repeat loop

**Table 9-414 DI\_CHAN2\_LUMA0\_RPT\_PAT 0x17B0**

Bit(s)	R/W	Default	Description
31-0	W/R	0	luma repeat pattern

**Table 9-415 DI\_CHAN2\_CHROMA0\_RPT\_PAT 0x17B1**

Bit(s)	R/W	Default	Description
7-0	W/R	0	chroma repeat loop

**Table 9-416 DI\_CHAN2\_DUMMY\_PIXEL 0x17B2**

Bit(s)	R/W	Default	Description
31-0	W/R	0x8080-00	dummy pixel

**Table 9-417 DI\_CHAN2\_LUMA\_FIFO\_SIZE 0x17B3**

Bit(s)	R/W	Default	Description
8-0	W/R	128	fifo size

**Table 9-418 DI\_CHAN2\_RANGE\_MAP\_Y 0x17B4**

Bit(s)	R/W	Default	Description
31-23	W/R	0	din offset
22-15	W/R	0	range map coef
13-10	W/R	0	range map din offset mult
9-1	W/R	0	dout offset
0	W/R	0	range map enable

**Table 9-419 DI\_CHAN2\_RANGE\_MAP\_CB 0x17B5**

Bit(s)	R/W	Default	Description
31-23	W/R	0	din offset
22-15	W/R	0	range map coef
13-10	W/R	0	range map din offset mult
9-1	W/R	0	dout offset
0	W/R	0	range map enable

**Table 9-420 DI\_CHAN2\_RANGE\_MAP\_CR 0x17B6**

Bit(s)	R/W	Default	Description
31-23	W/R	0	din offset
22-15	W/R	0	range map coef
13-10	W/R	0	range map din offset mult
9-1	W/R	0	dout offset
0	W/R	0	range map enable

**Table 9-421 DI\_CHAN2\_URGENT\_CTRL 0x17A6**

Bit(s)	R/W	Default	Description
13-16	W/R	0	urgent_ctrl_luma: bit 15: auto_urgent_en bit 14: urgent_wr bit 7-4: up_threshold bit 3-0: down_threshold
15-0	W/R	0	urgent_ctrl_chroma: bit 15: auto_urgent_en bit 14: urgent_wr bit 7-4: up_threshold bit 3-0: down_threshold

**Table 9-422 DI\_CHAN2\_FMT\_CTRL 0x17B8**

Bit(s)	R/W	Default	Description
31	R/W	0	gate_clk_en. 0=No clock gating, free-running; 1=Enable clock gating for power saving.
30	R/W	0	soft_rst. If true, reset formatters.
29	R/W	0	unused
28	R/W	0	if true, horizontal formatter use repeating to generate pixel, otherwise use bilinear interpolation
27-24	R/W	0	horizontal formatter initial phase
23	R/W	0	horizontal formatter repeat pixel 0 enable
22-21	R/W	0	horizontal Y/C ratio, 00: 1:1, 01: 2:1, 10: 4:1
20	R/W	0	horizontal formatter enable
19	R/W	0	if true, always use phase0 while vertical formatter, meaning always repeat data, no interpolation
18	R/W	0	if true, disable vertical formatter chroma repeat last line
17	R/W	0	vertical formatter dont need repeat line on phase0, 1: enable, 0: disable
16	R/W	0	vertical formatter repeat line 0 enable
15-12	R/W	0	vertical formatter skip line num at the beginning
11-8	R/W	0	vertical formatter initial phase
7-1	R/W	0	vertical formatter phase step (3.4)
0	R/W	0	vertical formatter enable

**Table 9-423 DI\_CHAN2\_FMT\_W 0x17B9**

Bit(s)	R/W	Default	Description
27-16	R/W	0	horizontal formatter width
12-0	R/W	0	vertical formatter width

**Table 9-424 DI\_NRWR\_CTRL 0x17C2**

Bit(s)	R/W	Default	Description
31	R/W	0	Pending_ddr_wrrsp_nrwr
30	R/W	0	Nrwr_reg_swap

Bit(s)	R/W	Default	Description
29-26	R/W	0	Nrwr_burst_lim
25	R/W	0	Nrwr_canvas_syncen
24	R/W	0	Nrwr_no_clk_gate
23-22	R/W	0	Nrwr_rgb_mode, 0: 4:2:2 to one canvas; 1: 4:4:4 to one canvas; 2: Y to luma canvas, CbCr to chroma canvas, for NV12/21; 3: Reserved.
21-20	R/W	0	Nrwr_hconv_mode
19-18	R/W	0	Nrwr_vconv_mode
17	R/W	0	Nrwr_swap_cbcr
16	R/W	0	Nrwr_urgent
15-8	R/W	0	Nrwr_canvas_index_chroma
7-0	R/W	0	Nrwr_canvas_index_luma

Table 9-425 DI\_NRWR\_X 0x17C0

Bit(s)	R/W	Default	Description
31	R/W	0	Nrwr_little_endian
30	R/W	0	Nrwr_rev_x
29-16	R/W	0	Nrwr_start_x
15-14	R/W	0	nrwr_words_lim[3:2]
13-0			Nrwr_end_x

Table 9-426 DI\_NRWR\_Y 0x17C1

Bit(s)	R/W	Default	Description
31-30	R/W	1	Nrwr_words_lim[1:0]
29	R/W	0	Nrwr_rev_y
28-16	R/W	0	Nrwr_start_y
15	R/W	0	Nrwr_ext_en
14	R/W	1	Nrwr bit10 mode
12-0	R/W	0	Nrwr_end_y

Table 9-427 DI\_DIWR\_CTRL 0x17C8

Bit(s)	R/W	Default	Description
31	R/W	0	Pending_ddr_wrrsp_Diwr
30	R/W	0	Diwr_reg_swap
29-26	R/W	0	Diwr_burst_lim
25	R/W	0	Diwr_canvas_syncen

Bit(s)	R/W	Default	Description
24	R/W	0	Diwr_no_clk_gate
23-22	R/W	0	Diwr_rgb_mode, 0: 4:2:2 to one canvas; 1: 4:4:4 to one canvas; 2: Y to luma canvas, CbCr to chroma canvas, for NV12/21; 3: Reserved.
21-20	R/W	0	Diwr_hconv_mode
19-18	R/W	0	Diwr_vconv_mode
17	R/W	0	Diwr_swap_cbcr
16	R/W	0	Diwr_urgent
15-8	R/W	0	Diwr_canvas_index_chroma
7-0	R/W	0	Diwr_canvas_index_luma

Table 9-428 DI\_DIWR\_X 0x17C6

Bit(s)	R/W	Default	Description
31	R/W	0	Diwr_little_endian
30	R/W	0	Diwr_rev_x
29-16	R/W	0	Diwr_start_x
15-14	R/W	0	Diwr_words_lim[3:2]
13-0			Diwr_end_x

Table 9-429 DI\_DIWR\_Y 0x17C7

Bit(s)	R/W	Default	Description
31-30	R/W	1	Diwr_words_lim[1:0]
29	R/W	0	Diwr_rev_y
28-16	R/W	0	Diwr_start_y
15	R/W	0	Diwr_ext_en
14	R/W	1	Diwr bit10 mode
12-0	R/W	0	Diwr_end_y

Table 9-430 DI\_CONTWR\_CTRL 0x17A2

Bit(s)	R/W	Default	Description
31	R/W	0	write : clear wrrsp; read : Pending_dds_wrrsp
11	R/W	0	canvas sync_enable
10	R/W	0	bits per pixel
8	R/W	0	urgent
7-0	R/W	0	canvas_index

## Di mad registers

Table 9-431 DI\_PRE\_GL\_CTRL 0x20ab

Bit(s)	R/W	Default	Description
31	W/R	0	pre count enable
30	W/R	0	pre count reset
29:16	W/R	0x20	total line number for pre count
15	W	0	pre mif manual start
13:0	W/R	0xc	the line number of pre frame reset

Table 9-432 DI\_PRE\_GL\_THD 0x20ac

Bit(s)	R/W	Default	Description
21:16	W/R	10	DI PRE hold line number
15:0	W/R	1920	H total pixel number for pre count

Table 9-433 DI\_POST\_GL\_CTRL 0x20ad

Bit(s)	R/W	Default	Description
31	W/R	0	post count enable
30	W/R	0	post count reset
29:16	W/R	0x20	total line number for post count
15	W	0	post mif manual start
13:0	W/R	0xc	the line number of post frame reset

Table 9-434 DI\_POST\_GL\_THD 0x20ae

Bit(s)	R/W	Default	Description
21:16	W/R	10	DI POST hold line number
15:0	W/R	1920	H total pixel number for post count

Table 9-435 DI\_PRE\_CTRL 0x1700

Bit(s)	R/W	Default	Description
31	W/R		cbus_pre_frame_rst
30	W/R		cbus_pre_soft_rst
29	W/R		pre_field_num
28	W/R		di mem mif bypass : 1:bypass
27:26	W/R		mode_444c422
25	W/R		di_cont_read_en
24:23	W/R		mode_422c444

Bit(s)	R/W	Default	Description
22	W/R		mtn_after_nr
21:16	W/R		pre_hold_fifo_lines
21	W/R		pre field num for nr
20	W/R		pre field num for pulldown
19	W/R		pre field num for mcdi
18	W/R		pd_mtn_swap
17	W/R		reg_me_autoen
16	W/R		reg_me_en
15	W/R		nr_wr_by
14	W/R		use_vdin_go_line
13	W/R		di_prevdin_en
12	W/R		di_pre_viu_link
11	W/R		di_chan3_enable
10	W/R		di_mcinfo_rd_mif_en
9	W/R		di_buf2_en
8	W/R		di_chan2_en
7	W/R		prenr_hist_en
6	W/R		chan2_hist_en
5	W/R		hist_check_en
4	W/R		check_after_nr
3	W/R		check222p_en
2	W/R		check322p_en
1	W/R		mtn_en
0	W/R		nr_en

Table 9-436 DI\_POST\_CTRL 0x1701

Bit(s)	R/W	Default	Description
31	W/R		cbus_post_frame_rst
30	W/R		cbus_post_soft_rst
29	W/R		post_field_num
21:16	W/R		post_hold_fifo_lines
14	W/R		mc vector invert 1:invert 0:no invert
13	W/R		prepost_link
12	W/R		di_post_viu_link
11	W/R		di_post_repeat



Bit(s)	R/W	Default	Description
10	W/R		di_post_drop_1st
9	W/R		mif0_to_vpp_en
8	W/R		di_vpp_out_en
7	W/R		di_wr_bk_en
6	W/R		di_mux_en
5	W/R		di_blend_en
4	W/R		di_mtnp_read_en
3	W/R		di_mcvec_read_en
2	W/R		di_ei_en
1	W/R		di_buf1_en
0	W/R		di_buf0_en

Table 9-437 DI\_POST\_SIZE 0x1702

Bit(s)	R/W	Default	Description
31:29	W/R	0	diwr_field_mode
28:16	W/R	0	vsize1post
12:0	W/R	0	hsize1post

Table 9-438 DI\_PRE\_SIZE 0x1703

Bit(s)	R/W	Default	Description
31:29	W/R	0	nrwr_field_mode
28:16	W/R	0	vsize1pre
12:0	W/R	0	hsize1pre

Table 9-439 DI\_EI\_CTRL0 0x1704

Bit(s)	R/W	Default	Description
23:16	W/R		ei0_filter[2:+] abs_diff_left>filter && ...right>filter && ...top>filter && ...bot>filter -> filter
15:8	W/R		ei0_threshold[2:+]
3	W/R		ei0_vertical
2	W/R		ei0_bpsc2
1	W/R		ei0_bpsfar1

**Table 9-440 DI\_EI\_CTRL1 0x1705**

Bit(s)	R/W	Default	Description
31:24	W/R		ei0_diff
23:16	W/R		ei0_angle45
15:8	W/R		ei0_peak
7:0	W/R		ei0_cross

**Table 9-441 DI\_EI\_CTRL2 0x1706**

Bit(s)	R/W	Default	Description
31:24	W/R		ei0_close2
23:16	W/R		ei0_close1
15:8	W/R		ei0_far2
7:0	W/R		ei0_far1

**Table 9-442 DI\_NR\_CTRL0 0x1707**

Bit(s)	R/W	Default	Description
26	W/R		nr_cue_en
25	W/R		nr2_en

**Table 9-443 DI\_NR\_CTRL1 0x1708**

Bit(s)	R/W	Default	Description
31:30	W/R		mot_p1txtcore_mode
29:24	W/R		mot_p1txtcore_clmt
21:16	W/R		mot_p1txtcore_ylmt
15:8	W/R		mot_p1txtcore_crate
7:0	W/R		mot_p1txtcore_yrate

**Table 9-444 DI\_NR\_CTRL2 0x1709**

Bit(s)	R/W	Default	Description
29:24	W/R		mot_curtxtcore_clmt
21:16	W/R		mot_curtxtcore_ylmt
15:8	W/R		mot_curtxtcore_crate
7:0	W/R		mot_curtxtcore_yrate

**Table 9-445 DI\_CANVAS\_URGENT0 0x170a**

Bit(s)	R/W	Default	Description
26	R/W	0	di write mif bvalid_sel: 1. Bvalid_singnal from bus, 0: bytes_wr handshakes
25	R/W	0	di write mif burst last sel: 1. All kind of burst last signal include ext_data_last. 0. Used the normal burst last signal
24:16	W/R	0	Di write mif urgent ctrl
9	R/W	0	nr write mif bvalid_sel: 1. Bvalid_singnal from bus, 0: bytes_wr handshakes
8	R/W	0	nr write mif burst last sel: 1. All kind of burst last signal include ext_data_last. 0. Used the normal burst last signal
7:0	W/R	0	Nr write mif urgent ctrl

**Table 9-446 DI\_MTN\_CTRL 0x170b**

Bit(s)	R/W	Default	Description
31	W/R	0	reg_mtn_1_en if 0x170b[0]=1 (DI_MTN_CTRL)
30	W/R	0	reg_mtn_init if 0x170b[0]=1 (DI_MTN_CTRL)
29	W/R	0	reg_di2nr_txt_en if 0x170b[0]=1 (DI_MTN_CTRL)
28	W/R	0	reg_di2nr_txt_mode if 0x170b[0]=1 (DI_MTN_CTRL)
27:24	W/R	0	reg_mtn_def if 0x170b[0]=1 (DI_MTN_CTRL)
23: 0	W/R	0	reserved

**Table 9-447 DI\_MTN\_CTRL1 0x170c**

Bit(s)	R/W	Default	Description
17	W/R		Invert NR field
16	W/R		Invert pulldown field
15	W/R		Invert mcdi field
14	W/R		Swap line0 and line2 of mtn input data
13	W/R		me enable
12	W/R		me autoenable
11:8	W/R		mtn_paramnthd
7:0	W/R		mtn_parafllthd

**Table 9-448 DI\_BLEND\_CTRL 0x170d**

Bit(s)	R/W	Default	Description
31	W/R		blend_1_en
30	W/R		blend_mtn_lpf
28	W/R		post_mb_en
27	W/R		blend_mtn3p_max

Bit(s)	R/W	Default	Description
26	W/R		blend_mtn3p_min
25	W/R		blend_mtn3p_ave
24	W/R		blend_mtn3p_maxtb
23	W/R		blend_mtn_fit_en
22	W/R		blend_data_fit_en
21:20	W/R		blend_top_mode 00: mtn, 01: weave mode, 10: bob mode, 11 : blend mode
19	W/R		blend_reg3_enable
18	W/R		blend_reg2_enable
17	W/R		blend_reg1_enable
16	W/R		blend_reg0_enable
15:14	W/R		blend_reg3_mode
13:12	W/R		blend_reg2_mode
11:10	W/R		blend_reg1_mode
9:8	W/R		blend_reg0_mode
7:0	W/R		kdeint

Table 9-449 DI\_CANVAS\_URGENT2 0x170e

Bit(s)	R/W	Default	Description
31:16	W/R	0	Mtn_rd_urgent_ctrl
15:0	W/R	0	cont_rd_urgent_ctrl

Table 9-450 DI\_ARB\_CTRL 0x170f

Bit(s)	R/W	Default	Description
31:26	W/R	0x20	Di_arb_thd1
25:20	W/R	0x20	Di_arb_thd0
19	W/R	0	Di_arb_tid_mode
18	W/R	0	Di_arb_arb_mode
17	W/R	0	Di_arb_acg_en
16	W/R	0	Di_arb_disable_clk
15:0	W/R	0	Di_arb_req_en

**Table 9-451 DI\_BLEND\_REG0\_X 0x1710**

Bit(s)	R/W	Default	Description
28:16	W/R		blend_reg0_startx
12:0	W/R		blend_reg0_endx

DI\_BLEND\_REG0\_Y 0x1711

DI\_BLEND\_REG1\_X 0x1712

DI\_BLEND\_REG1\_Y 0x1713

DI\_BLEND\_REG2\_X 0x1714

DI\_BLEND\_REG2\_Y 0x1715

DI\_BLEND\_REG3\_X 0x1716

DI\_BLEND\_REG3\_Y 0x1717

**Table 9-452 DI\_EI\_CTRL4 0x171a**

Bit(s)	R/W	Default	Description
29	W/R	0	reg_ei_caldrdt_amblike2_biasvertical
28:24	W/R	21	reg_ei_caldrdt_addxla2list_drtmax
23	W/R	0	N/A
22:20	W/R	1	reg_ei_caldrdt_addxla2list_signm0th
19	W/R	1	reg_ei_caldrdt_addxla2list_mode
18:16	W/R	3	reg_ei_signm_sad_cor_rate
15:12	W/R	3	reg_ei_signm_sadi_cor_rate
11:6	W/R	2	reg_ei_signm_sadi_cor_ofst
5:0	W/R	4	reg_ei_signm_sad_ofst

**Table 9-453 DI\_EI\_CTRL5 0x171b**

Bit(s)	R/W	Default	Description
30:28	W/R	5	reg_ei_caldrdt_cnflctchk_frcoverthrd
27	W/R	0	N/A
26:24	W/R	2	reg_ei_caldrdt_cnflctchk_mg
23:22	W/R	1	reg_ei_caldrdt_cnflctchk_ws
21	W/R	1	reg_ei_caldrdt_cnflctchk_en
20	W/R	1	reg_ei_caldrdt_verfrfc_final_en
19	W/R	0	reg_ei_caldrdt_verfrfc_retimflt_en
18:16	W/R	3	reg_ei_caldrdt_verfrfc_eithratemth
15	W/R	0	reg_ei_caldrdt_verfrfc_retiming_en
14:12	W/R	2	reg_ei_caldrdt_verfrfc_bothratemth

Bit(s)	R/W	Default	Description
11:9	W/R	0	reg_ei_caldr_t_ver_thr
8:4	W/R	4	reg_ei_caldr_t_addxla2list_drtmin
3:0	W/R	15	reg_ei_caldr_t_addxla2list_drtlimit

Table 9-454 DI\_EI\_CTRL6 0x171c

Bit(s)	R/W	Default	Description
31:24	W/R	80	reg_ei_caldr_t_abext_sad12thhigh
23:16	W/R	35	reg_ei_caldr_t_abext_sad00thlow
15:8	W/R	28	reg_ei_caldr_t_abext_sad12thlow
6:4	W/R	1	reg_ei_caldr_t_abext_ratemth
2:0	W/R	5	reg_ei_caldr_t_abext_drtthrd

Table 9-455 DI\_EI\_CTRL7 0x171d

Bit(s)	R/W	Default	Description
29	W/R	1	reg_ei_caldr_t_xlanopeak_codien
28:24	W/R	15	reg_ei_caldr_t_xlanopeak_drtmax
23	W/R	1	reg_ei_caldr_t_xlanopeak_en
22:20	W/R	3	reg_ei_caldr_t_abext_monotrnd_alpha
19:18	W/R	1	reg_ei_caldr_t_abext_mononum12_thr
17:16	W/R	1	reg_ei_caldr_t_abext_mononum00_thr
15:12	W/R	6	reg_ei_caldr_t_abext_sad00rate
11:8	W/R	6	reg_ei_caldr_t_abext_sad12rate
7:0	W/R	80	reg_ei_caldr_t_abext_sad00thhigh

Table 9-456 DI\_EI\_CTRL8 0x171e

Bit(s)	R/W	Default	Description
30:28	W/R	2	reg_ei_assign_headtail_magin
26:24	W/R	3	reg_ei_retime_lastcurpncnftchk_mode
22:21	W/R	0	reg_ei_retime_lastcurpncnftchk_drtth
13:11	W/R	3	reg_ei_caldr_t_amblike2_drtmg
10:8	W/R	1	reg_ei_caldr_t_amblike2_valmg
7:4	W/R	10	reg_ei_caldr_t_amblike2_alpha
3:0	W/R	4	reg_ei_caldr_t_amblike2_drtth

**Table 9-457 DI\_EI\_CTRL9 0x171f**

Bit(s)	R/W	Default	Description
31:28	W/R	7	reg_ei_caldrt_hcnfcheck_frcvert_xla_th3
27	W/R	1	reg_ei_caldrt_hcnfcheck_frcvert_xla_en
26:24	W/R	4	reg_ei_caldrt_conf_drth
23:20	W/R	11	reg_ei_caldrt_conf_absdrth
19:18	W/R	2	reg_ei_caldrt_abcheck_mode1
17:16	W/R	1	reg_ei_caldrt_abcheck_mode0
15:12	W/R	11	reg_ei_caldrt_abcheck_drth1
11:8	W/R	11	reg_ei_caldrt_abcheck_drth0
6:4	W/R	3	reg_ei_caldrt_abpnchk1_th
1	W/R	1	reg_ei_caldrt_abpnchk1_en
0	W/R	1	reg_ei_caldrt_abpnchk0_en

**Table 9-458 DI\_EI\_CTRL10 0x1793**

Bit(s)	R/W	Default	Description
31:28	W/R	0	reg_ei_caldrt_hstrgchk_drth
27:24	W/R	8	reg_ei_caldrt_hstrgchk_frcverthrd
23:20	W/R	4	reg_ei_caldrt_hstrgchk_mg
19	W/R	0	reg_ei_caldrt_hstrgchk_1sidnul
18	W/R	0	reg_ei_caldrt_hstrgchk_excpcnf
17:16	W/R	2	reg_ei_caldrt_hstrgchk_ws
15	W/R	1	reg_ei_caldrt_hstrgchk_en
14:13	W/R	2	reg_ei_caldrt_hpncheck_mode
12	W/R	0	reg_ei_caldrt_hpncheck_mute
11:9	W/R	3	reg_ei_caldrt_hcnfcheck_mg2
8:6	W/R	2	reg_ei_caldrt_hcnfcheck_mg1
5:4	W/R	2	reg_ei_caldrt_hcnfcheck_mode
3:0	W/R	9	reg_ei_caldrt_hcnfcheck_frcvert_xla_th5

**Table 9-459 DI\_EI\_CTRL11 0x179e**

Bit(s)	R/W	Default	Description
30:29	W/R	2	reg_ei_amb_detect_mode
28:24	W/R	8	reg_ei_amb_detect_winth
23:21	W/R	3	reg_ei_amb_decide_rppth
20:19	W/R	1	reg_ei_retime_lastmappncnflthk_drth

Bit(s)	R/W	Default	Description
18:16	W/R	2	reg_ei_retime_lastmappncnftchk_mode
15:14	W/R	2	reg_ei_retime_lastmapvertfcchk_mode
13:12	W/R	3	reg_ei_retime_lastvertfcchk_mode
11:8	W/R	0	reg_ei_retime_lastpnchk_drth
6	W/R	1	reg_ei_retime_lastpnchk_en
5:4	W/R	3	reg_ei_retime_mode
3	W/R	1	reg_ei_retime_last_en
2	W/R		reg_ei_retime_ab_en
1	W/R	1	reg_ei_caldrth_hstrvertfcchk_en
0	W/R	0	reg_ei_caldrth_hstrgchk_mode

Table 9-460 DI\_EI\_CTRL12 0x179f

Bit(s)	R/W	Default	Description
31:28	W/R	13	reg_ei_drtdelay2_lmt
27:26	W/R	2	reg_ei_drtdelay2_notver_lrwin
25:24	W/R	3	reg_ei_drtdelay_mode
23	W/R	0	reg_ei_drtdelay2_mode
22:20	W/R	0	reg_ei_assign_xla_signm0th
19	W/R	1	reg_ei_assign_pkbiasvert_en
18	W/R	1	reg_ei_assign_xla_en
17:16	W/R	0	reg_ei_assign_xla_mode
15:12	W/R	2	reg_ei_assign_nlfilter_magin
11:8	W/R	5	reg_ei_localsearch_maxrange
7:4	W/R	0	reg_ei_xla_drth
3:0	W/R	3	reg_ei_flatmsad_thrd

Table 9-461 DI\_EI\_CTRL13 0x17a8

Bit(s)	R/W	Default	Description
27:24	W/R	15	reg_ei_int_drt2x_chrdrt_limit
23:20	W/R	0	reg_ei_int_drt16x_core
19:16	W/R	2	reg_ei_int_drtdelay2_notver_cancv
15:8	W/R	20	reg_ei_int_drtdelay2_notver_sadth
7:0	W/R	20	reg_ei_int_drtdelay2_vlddrt_sadth



Table 9-462 DI\_EI\_DRT\_CTRL 0x2028

Bit(s)	R/W	Default	Description
31	W/R	0	reg_rectg_en: Low angle enable.
30	W/R	0	reg_recbld_en: New and old drt blend enable.
29:28	W/R	2	reg_rectg_ws : window side to calculate the reference direction: 0:1x1; 1:1x3; 2:1x5; 3:1x7
27			reserved
26:24	W/R	2	reg_abq_margin : top and bottom curve trend quantization margin of noise for direction assignments.
23			reserved
22:20	W/R	3	reg_trend_mg : the Margin of the top/bot trend.
19:16	W/R	1	reg_int_d16xc1 : Coring to drtf.
15:14			reserved
13:8	W/R	40	reg_int_chlmt1: Limit to drtf(16x) for chroma angle
7			reserved
6:4	W/R	5	reg_nscheck_thrd:check whether the pixels id noise or not.
3			reserved
2:0	W/R	7	reg_horsl_ws: window side to check the existent number of low angle drt, if the number<the value, drt=raw drt

Table 9-463 DI\_EI\_DRT\_PIXTH 0x2029

Bit(s)	R/W	Default	Description
31: 24	W/R	22	reg_min_pix: the threshold of min pix of photos, <threshold the pix do not participate in the monotonic trend calculation.
23:16	W/R	203	reg_max_pix:the threshold of max pix of photos, >threshold the pix do not participate in the monotonic trend calculation.
15:8	W/R	50	reg_dmaxmin_thrdma: the max pixel and min pixel difference is larger than the value the trend existent.
7:0	W/R	30	reg_dmaxmin_thrdmi: the max pixel and min pixel difference is smaller than the value the trend non-existent.

Table 9-464 DI\_EI\_DRT\_CORRPIXTH 0x202a

Bit(s)	R/W	Default	Description
31: 24	W/R	40	reg_newcorrpix_maxthrd:the new low angle drt sad threshold.
23:16	W/R	60	reg_corrpx_diffthrd: the top and bottom pixel difference is larger than the value, the case may be ultra-low angle.
15:8	W/R	10	reg_corrpx_minthrd: the difference of top and bottom pixel is smaller than the value, the drt may be raw drt.
7:0	W/R	20	reg_corrpx_maxthrd: the difference of top and bottom pixel is larger than the value, the drt may be raw drt.

Table 9-465 DI\_EI\_DRT\_RECTG\_WAVE 0x202b

Bit(s)	R/W	Default	Description
31:29			reserved
28:24	W/R	0	reg_max_pixwave: the wave of the max pix threshold, prevent min pix close to reg_max_pix caused the number between max and min pix zeros.
23:21			reserved
20:16	W/R	15	reg_pix_wave: the wave of the max and min pix, the max pixel smaller than the value or the min pixel larger than the value, may be the ultra-low angle case.
15:14			reserved
13:8	W/R	40	reg_maxdrt_thr: the threshold of the low angle max drt.
7:0	W/R	20	reg_wave_thr:in bilateral cases tow pixel difference is smaller than the value, the trend between the tow pixel not change.

Table 9-466 DI\_EI\_DRT\_PIX\_DIFFTH 0x202c

Bit(s)	R/W	Default	Description
31: 24	W/R	32	reg_newraw_thr: the old drt and new drt transition threshold.
23:16	W/R	10	reg_tb_max_thr: the threshold of top and bottom max or min pixel.
15:8	W/R	20	reg_diffpix_thr: Max-Min<the value,the trend is non-existent
7:6			reserved
5:0	W/R	5	reg_bilt_trendnum: in bilateral cases the difference between the top and bottom pixel number of the monotonic trend smaller than the value is low angle.

Table 9-467 DI\_EI\_DRT\_UNBITREND\_TH 0x202d

Bit(s)	R/W	Default	Description
31:29			reserved
28:24	W/R	10	reg_trend_num:in bilateral cases the pixel number of the monotonic trend larger than the value is low angle.
23:21			reserved
20:16	W/R	4	reg_bilt_trendnum:in bilateral cases the pixel number of the trend larger than the value is low angle.
15:13			reserved
12:8	W/R	7	reg_unil_trendnum: in unilateral cases the difference between the top and bottom pixel number of the monotonic trend smaller than the value is low angle.
7:5			reserved
4:0	W/R	10	reg_trend_num: in unilateral cases the pixel number of the trend larger than the value is ultra-low angle.

**Table 9-468 DI\_EI\_XWIN0 0x1798**

Bit(s)	R/W	Default	Description
27:16	W/R		ei_xend0
11:0	W/R		ei_xstart0

DI\_EI\_XWIN1 0x1799

**Table 9-469 DI\_MC\_REG0\_X 0x1720**

Bit(s)	R/W	Default	Description
27:16	W/R		mc_reg0_start_x
11:0	W/R		mc_reg0_end_x

DI\_MC\_REG0\_Y 0x1721

DI\_MC\_REG1\_X 0x1722

DI\_MC\_REG1\_Y 0x1723

DI\_MC\_REG2\_X 0x1724

DI\_MC\_REG2\_Y 0x1725

DI\_MC\_REG3\_X 0x1726

DI\_MC\_REG3\_Y 0x1727

DI\_MC\_REG4\_X 0x1728

DI\_MC\_REG4\_Y 0x1729

**Table 9-470 DI\_MC\_32LVL0 0x172a**

Bit(s)	R/W	Default	Description
31:24	W/R		mc_reg2_32lvl
23:16	W/R		mc_reg1_32lvl
15:8	W/R		mc_reg0_32lvl
7:0	W/R		field_32lvl

**Table 9-471 DI\_MC\_32LVL1 0x172b**

Bit(s)	R/W	Default	Description
15:8	W/R		mc_reg3_32lvl
7:0	W/R		mc_reg4_32lvl

**Table 9-472 DI\_MC\_22LVL0 0x172c**

Bit(s)	R/W	Default	Description
31:16	W/R		mc_reg0_22lvl
15:0	W/R		field_22lvl

**Table 9-473 DI\_MC\_22LVL1 0x172d**

Bit(s)	R/W	Default	Description
31:16	W/R		mc_reg2_22lvl
15:0	W/R		mc_reg1_22lvl

**Table 9-474 DI\_MC\_22LVL2 0x172e**

Bit(s)	R/W	Default	Description
31:16	W/R		mc_reg4_22lvl
15:0	W/R		mc_reg3_22lvl

**Table 9-475 DI\_MC\_CTRL 0x172f**

Bit(s)	R/W	Default	Description
4	W/R		mc_reg4_en
3	W/R		mc_reg3_en
2	W/R		mc_reg2_en
1	W/R		mc_reg1_en
0	W/R		mc_reg0_en

**Table 9-476 DI\_INTR\_CTRL 0x1730**

Bit(s)	R/W	Default	Description
31	W/R	0	when Deint_irq_mode =0: if predi_int/postdi_int is generated, interrupt flag will be set; Deint_irq_mode==1:when any DI internal interrupt source generate an interrupt, and there is no Mask operation, the interrupt flag will be set
30:26	W/R	0	reserved
25	w/R	0	NrDownscale_int_mask
24	w/R	0	Det3d_int_mask
23	w/R	0	Mcinfowr_int_mask
22	w/R	0	Mcvecwr_int_mask
21	w/R	0	Medi_int_mask
20	w/R	0	Contwr_int_mask
19	w/R	0	Hist_int_mask
18	w/R	0	Diwr_int_mask
17	w/R	0	Mtn_wr_int_mask
16	w/R	0	Nrwr_int_mask
15:10	W/R	0	reserved
9	R		Nrdownscale_done

Bit(s)	R/W	Default	Description
8	R		Det3d_done
7	R		Mcinfowr_done (not valid in GX)
6	R		Mcvecwr_done (not valid in GX)
5	R		Medi_done(not valid in GX)
4	R		Contwr_done
3	R		Hist_done
2	R		diwr_done
1	R		Mtnwr_done
0	R		Nrwr_done

DI\_INFO\_ADDR 0x1731

Table 9-477 Addr\_0

Bit(s)	R/W	Default	Description
31:0	R		Field_32p , sum of difference between n-2 and n

Table 9-478 Addr\_1

Bit(s)	R/W	Default	Description
31:24	R		Field_32max, maximum difference between n-2 and n
23:0	R		Field_32num, numbers of pixels difference > threshold

Table 9-479 Addr\_2

Bit(s)	R/W	Default	Description
31:0	R		Field_22p, sum of difference between temporal and vertical difference

Table 9-480 Addr\_3

Bit(s)	R/W	Default	Description
15:0	R		Field_22max , maximum difference between temporal and verticaldifference

Table 9-481 Addr\_4

Bit(s)	R/W	Default	Description
23:0	R		Field_22num, pixel sum which difference > threshold

**Table 9-482 Addr\_5**

Bit(s)	R/W	Default	Description
31:0	R		Luma sum

**Table 9-483 Addr\_6**

Bit(s)	R/W	Default	Description
31:0	R		Difference of 32, sum in area 0

**Table 9-484 Addr\_7**

Bit(s)	R/W	Default	Description
31:0	R		Difference of 32, sum in area 1

**Table 9-485 Addr\_8**

Bit(s)	R/W	Default	Description
31:0	R		Difference of 32, sum in area 2

**Table 9-486 Addr\_9**

Bit(s)	R/W	Default	Description
31:0	R		Difference of 32, sum in area 3

**Table 9-487 Addr\_10**

Bit(s)	R/W	Default	Description
31:0	R		Difference of 32, sum in area 4

**Table 9-488 Addr\_11**

Bit(s)	R/W	Default	Description
31:0	R		Difference of 22, sum in area 0

**Table 9-489 Addr\_12**

Bit(s)	R/W	Default	Description
31:0	R		Difference of 22, sum in area 1

**Table 9-490 Addr\_13**

Bit(s)	R/W	Default	Description
31:0	R		Difference of 22, sum in area 2

**Table 9-491 Addr\_14**

Bit(s)	R/W	Default	Description
31:0	R		Difference of 22, sum in area 3

**Table 9-492 Addr\_15**

Bit(s)	R/W	Default	Description
31:0	R		Difference of 22, sum in area 4

**Table 9-493 Addr\_16**

Bit(s)	R/W	Default	Description
31:0	R		luma, sum in area 0

**Table 9-494 Addr\_17**

Bit(s)	R/W	Default	Description
31:0	R		luma, sum in area 1

**Table 9-495 Addr\_18**

Bit(s)	R/W	Default	Description
31:0	R		luma, sum in area 2

**Table 9-496 Addr\_19**

Bit(s)	R/W	Default	Description
31:0	R		luma, sum in area 3

**Table 9-497 Addr\_20**

Bit(s)	R/W	Default	Description
31:0	R		luma, sum in area 4

**Table 9-498 Addr\_21**

Bit(s)	R/W	Default	Description
31:24	R		Field_32max, maximum difference between n-2 and n in area0
23:0	R		Field_32num, numbers of pixels difference > threshold in area0

**Table 9-499 Addr\_22**

Bit(s)	R/W	Default	Description
31:24	R		Field_32max, maximum difference between n-2 and n in area1
23:0	R		Field_32num, numbers of pixels difference > threshold in area1

**Table 9-500 Addr\_23**

Bit(s)	R/W	Default	Description
31:24	R		Field_32max, maximum difference between n-2 and n in area2
23:0	R		Field_32num, numbers of pixels difference > threshold in area2

**Table 9-501 Addr\_24**

Bit(s)	R/W	Default	Description
31:24	R		Field_32max, maximum difference between n-2 and n in area3
23:0	R		Field_32num, numbers of pixels difference > threshold in area3

**Table 9-502 Addr\_25**

Bit(s)	R/W	Default	Description
31:24	R		Field_32max, maximum difference between n-2 and n in area4
23:0	R		Field_32num, numbers of pixels difference > threshold in area4

**Table 9-503 Addr\_26**

Bit(s)	R/W	Default	Description
31:20	R		Field_22max/16, in area 0
19:0	R		Field_22 num/16, in area 0

**Table 9-504 Addr\_27**

Bit(s)	R/W	Default	Description
31:20	R		Field_22max/16, in area 1
19:0	R		Field_22 num/16, in area 1

**Table 9-505 Addr\_28**

Bit(s)	R/W	Default	Description
31:20	R		Field_22max/16, in area 2
19:0	R		Field_22 num/16, in area 2



**Table 9-506 Addr\_29**

Bit(s)	R/W	Default	Description
31:20	R		Field_22max/16, in area 3
19:0	R		Field_22 num/16, in area 3

**Table 9-507 Addr\_30**

Bit(s)	R/W	Default	Description
31:20	R		Field_22max/16, in area 4
19:0	R		Field_22 num/16, in area 4

DI\_INFO\_DATA 0x1732

**Table 9-508 DI\_PRE\_HOLD 0x1733**

Bit(s)	R/W	Default	Description
31	R/W	0	cntl_pre_hold_enable
27:16	R/W	0	cntl_pre_hold_count
11:0	R/W	0	cntl_pre_pass_count

**Table 9-509 DI\_MTN\_1\_CTRL1 0x1740**

Bit(s)	R/W	Default	Description
31	W/R		reg_mtn_1_en if 0x170b[0]=0 (DI_MTN_CTRL)
30	W/R		reg_mtn_init if 0x170b[0]=0 (DI_MTN_CTRL)
29	W/R		reg_di2nr_txt_en if 0x170b[0]=0 (DI_MTN_CTRL)
28	W/R		reg_di2nr_txt_mode if 0x170b[0]=0 (DI_MTN_CTRL)
27:24	W/R		reg_mtn_def if 0x170b[0]=0 (DI_MTN_CTRL)
23:16	W/R	32	reg_DI_cmb_adp_YCrate
15: 8	W/R	32	reg_DI_cmb_adp_2Crate
7: 0	W/R	21	reg_DI_cmb_adp_2Yrate

**Table 9-510 DI\_MTN\_1\_CTRL2 0x1741**

Bit(s)	R/W	Default	Description
31:24	W/R	26	reg_DI_m1b_core_Ykinter
23:16	W/R	26	reg_DI_m1b_core_Ckinter
15:8	W/R	58	reg_DI_m1b_core_Ykintra
7:0	W/R	98	reg_DI_m1b_core_Ckintra

**Table 9-511 DI\_MTN\_1\_CTRL3 0x1742**

Bit(s)	R/W	Default	Description
31:24	W/R	21	reg_DI_m1b_thr_2Yrate
23:16	W/R	32	reg_DI_m1b_thr_2Crate
15: 8	W/R	10	reg_DI_m1b_core_mxcmbY
7: 0	W/R	10	reg_DI_m1b_core_mxcmbC

**Table 9-512 DI\_MTN\_1\_CTRL4 0x1743**

Bit(s)	R/W	Default	Description
31:24	W/R	1	reg_DI_m1b_coreY
23:16	W/R	0	reg_DI_m1b_coreC
15: 8	W/R	8	reg_DI_m1b_thrd_min
7: 0	W/R	128	reg_DI_m1b_thrd_max

**Table 9-513 DI\_MTN\_1\_CTRL5 0x1744**

Bit(s)	R/W	Default	Description
31:27	W/R	7	reg_DI_m1b_pp_extnd_num
27:24	W/R	4	reg_DI_m1b_pp_errod_num
21:20	W/R	0	Re_di2nr_txt_mode 0:average of top/bot 1:max; 2:  a+c-2b ;
15: 8	W/R	13	reg_DI_mot_core_Ykinter
7: 0	W/R	13	reg_DI_mot_core_Ckinter

**Table 9-514 DI\_MTN\_1\_CTRL6 0x17a9**

Bit(s)	R/W	Default	Description
31:24	W/R	13	reg_DI_mot_core_Ykintra
23:16	W/R	90	reg_DI_mot_core_Ckintra
15: 8	W/R	21	reg_DI_mot_cor_2Yrate
7: 0	W/R	32	reg_DI_mot_cor_2Crate

**Table 9-515 DI\_MTN\_1\_CTRL7 0x17aa**

Bit(s)	R/W	Default	Description
31:24	W/R	10	reg_DI_mot_core_mxcmbY
23:16	W/R	10	reg_DI_mot_core_mxcmbC
15: 8	W/R	2	reg_DI_mot_coreY
7: 0	W/R	1	reg_DI_mot_coreC

**Table 9-516 DI\_MTN\_1\_CTRL8 0x17ab**

Bit(s)	R/W	Default	Description
31:24	W/R	26	reg_DI_fmot_core_Ykinter
23:16	W/R	26	reg_DI_fmot_core_Ckinter
15: 8	W/R	38	reg_DI_fmot_core_Ykintra
7: 0	W/R	98	reg_DI_fmot_core_Ckintra

**Table 9-517 DI\_MTN\_1\_CTRL9 0x17ac**

Bit(s)	R/W	Default	Description
31:24	W/R	13	reg_DI_fmot_cor_2Yrate
23:16	W/R	32	reg_DI_fmot_cor_2Crate
15: 8	W/R	3	reg_DI_fmot_coreY
7: 0	W/R	2	reg_DI_fmot_coreC

**Table 9-518 DI\_MTN\_1\_CTRL10 0x17ad**

Bit(s)	R/W	Default	Description
27:24	W/R	2	reg_DI_m1b_suremot_num_fld0
19:16	W/R	2	reg_DI_m1b_surestl_num_fld0
11: 8	W/R	6	reg_DI_m1b_suremot_num_fld1
3: 0	W/R	6	reg_DI_m1b_surestl_num_fld1

**Table 9-519 DI\_MTN\_1\_CTRL11 0x17ae**

Bit(s)	R/W	Default	Description
27:24	W/R	5	reg_DI_m1b_suremot_evn_th
20:16	W/R	8	reg_DI_m1b_suremot_odd_th
11: 8	W/R	3	reg_DI_m1b_surestl_evn_th
6	W/R	0	reg_DI_m1b_suremot_fast_en
5	W/R	0	reg_DI_m1b_surestl_fast_en
4: 0	W/R	4	reg_DI_m1b_surestl_odd_th

**Table 9-520 DI\_MTN\_1\_CTRL12 0x17af**

Bit(s)	R/W	Default	Description
31:24	W/R	64	reg_DI_mot_norm_gain
17:16	W/R	2	reg_DI_mot_alpha_lpf
15: 8	W/R	10	reg_DI_m1b_surestl_thrd
4: 0	W/R	4	reg_DI_mot_surestl_gain

### 9.2.3.8 NR2 Registers

**Table 9-521 DET3D\_MOTN\_CFG**

Bit(s)	R/W	Default	Description
16	R/W	0	reg_det3d_intr_en : Det3d interrupt enable
9:8	R/W	0	reg_Det3D_Motion_Mode : U2 Different mode for Motion Calculation of Luma and Chroma: 0 : MotY, 1: $(2 * \text{MotY} + (\text{MotU} + \text{MotV})) / 4$ ; 2: $\text{Max}(\text{MotY}, \text{MotU}, \text{MotV})$ ; 3: $\text{Max}(\text{MotY}, (\text{MotU} + \text{MotV}) / 2)$
7:4	R/W	0	reg_Det3D_Motion_Core_Rate : U4 K Rate to Edge (HV) details for coring of Motion Calculations, normalized to 32
3:0	R/W	0	reg_Det3D_Motion_Core_Thrd : U4 2X: static coring value for Motion Detection.

**Table 9-522 DET3D\_CB\_CFG**

Bit(s)	R/W	Default	Description
7:4	R/W	0	reg_Det3D_ChessBd_HV_ofst : U4, Noise immune offset for Horizontal or vertical combing detection.
3:0	R/W	0	reg_Det3D_ChessBd_NHV_ofst : U4, Noise immune offset for NON-Horizontal or vertical combing detection.

**Table 9-523 DET3D\_SPLT\_CFG 0x1736**

Bit(s)	R/W	Default	Description
7:4	R/W	0x0	reg_Det3D_SplitValid_ratio : U4, Ratio between max_value and the avg_value of the edge mapping for split line valid detection. The smaller of this value, the easier of the split line detected.
3:0	R/W	0x0	reg_Det3D_AvgIdx_ratio : U4, Ratio to the avg_value of the edge mapping for split line position estimation. The smaller of this value, the more samples will be added to the estimation.

**Table 9-524 DET3D\_HV\_MUTE 0x1737**

Bit(s)	R/W	Default	Description
23:20	R/W	0x0	reg_Det3D_Edge_Ver_Mute : U4 X2: Horizontal pixels to be mute from H/V Edge calculation Top and Bottom border part.
19:16	R/W	0x0	reg_Det3D_Edge_Hor_Mute : U4 X2: Horizontal pixels to be mute from H/V Edge calculation Left and right border part.
15:12	R/W	0x0	reg_Det3D_ChessBd_Ver_Mute : U4 X2: Horizontal pixels to be mute from ChessBoard statistics calculation in middle part
11:8	R/W	0x0	reg_Det3D_ChessBd_Hor_Mute : U4 X2: Horizontal pixels to be mute from ChessBoard statistics calculation in middle part
7:4	R/W	0x0	reg_Det3D_STA8X8_Ver_Mute : U4 1X: Vertical pixels to be mute from 8x8 statistics calculation in each block.
3:0	R/W	0x0	reg_Det3D_STA8X8_Hor_Mute : U4 1X: Horizontal pixels to be mute from 8x8 statistics calculation in each block.

**Table 9-525 DET3D\_MAT\_STA\_P1M1 0x1738**

Bit(s)	R/W	Default	Description
31:24	R/W	0x0	reg_Det3D_STA8X8_P1_K0_R8 : U8 SAD to SAI ratio to decide P1, normalized to 256 (0.8)
23:16	R/W	0x0	reg_Det3D_STA8X8_P1_K1_R7 : U8 SAD to ENG ratio to decide P1, normalized to 128 (0.5)
15:8	R/W	0x0	reg_Det3D_STA8X8_M1_K0_R6 : U8 SAD to SAI ratio to decide M1, normalized to 64 (1.1)
7:0	R/W	0x0	reg_Det3D_STA8X8_M1_K1_R6 : U8 SAD to ENG ratio to decide M1, normalized to 64 (0.8)

**Table 9-526 DET3D\_MAT\_STA\_P1TH 0x1739**

Bit(s)	R/W	Default	Description
23:16	R/W	0x0	reg_Det3D_STAYUV_P1_TH_L4 : U8 SAD to ENG Thrd offset to decide P1, X16 (100)
15:8	R/W	0x0	reg_Det3D_STAEDG_P1_TH_L4 : U8 SAD to ENG Thrd offset to decide P1, X16 (80)
7:0	R/W	0x0	reg_Det3D_STAMOT_P1_TH_L4 : U8 SAD to ENG Thrd offset to decide P1, X16 (48)

**Table 9-527 DET3D\_MAT\_STA\_M1TH 0x173a**

Bit(s)	R/W	Default	Description
23:16	R/W	0x0	reg_Det3D_STAYUV_M1_TH_L4 : U8 SAD to ENG Thrd offset to decide M1, X16 (100)
15:8	R/W	0x0	reg_Det3D_STAEDG_M1_TH_L4 : U8 SAD to ENG Thrd offset to decide M1, X16 (80)
7:0	R/W	0x0	reg_Det3D_STAMOT_M1_TH_L4 : U8 SAD to ENG Thrd offset to decide M1, X16 (64)

**Table 9-528 DET3D\_MAT\_STA\_RSFT 0x173b**

Bit(s)	R/W	Default	Description
5:4	R/W	0x0	reg_Det3D_STAYUV_RSHFT : U2 YUV statistics SAD and SAI calculation result right shift bits to accommodate the 12bits clipping: 0 : mainly for images <=720x480; 1: mainly for images <=1366x768; 2: mainly for images <=1920X1080; 2; 3: other higher resolutions
3:2	R/W	0x0	reg_Det3D_STAEDG_RSHFT : U2 Horizontal and Vertical Edge Statistics SAD and SAI calculation result right shift bits to accommodate the 12bits clipping: 0 : mainly for images <=720x480; 1: mainly for images <=1366x768; 2: mainly for images <=1920X1080; 2; 3: other higher resolutions
1:0	R/W	0x0	reg_Det3D_STAMOT_RSHFT : U2 Motion SAD and SAI calculation result right shift bits to accommodate the 12bits clipping: 0 : mainly for images <=720x480; 1: mainly for images <=1366x768; 2: mainly for images <=1920X1080; 2; 3: other higher resolutions

**Table 9-529 DET3D\_MAT\_SYMTC\_TH 0x173c**

Bit(s)	R/W	Default	Description
31:24	R/W	0x0	reg_Det3D_STALUM_symtc_Th : U8 threshold to decide if the Luma statistics is TB or LR symmetric.
23:16	R/W	0x0	reg_Det3D_STACHR_symtc_Th : U8 threshold to decide if the Chroma (UV) statistics is TB or LR symmetric.
15:8	R/W	0x0	reg_Det3D_STAEDG_symtc_Th : U8 threshold to decide if the Horizontal and Vertical Edge statistics is TB or LR symmetric.
7:0	R/W	0x0	reg_Det3D_STAMOT_symtc_Th : U8 threshold to decide if the Motion statistics is TB or LR symmetric.

**Table 9-530 DET3D\_RO\_DET\_CB\_HOR 0x173d**

Bit(s)	R/W	Default	Description
31:16	R.O	0x0	RO_Det3D_ChessBd_NHor_value : U16 X64: number of Pixels of Horizontally Surely NOT matching Chessboard pattern.
15:0	R.O	0x0	RO_Det3D_ChessBd_Hor_value : U16 X64: number of Pixels of Horizontally Surely matching Chessboard pattern.

**Table 9-531 DET3D\_RO\_DET\_CB\_VER 0x173e**

Bit(s)	R/W	Default	Description
31:16	R.O	0x0	RO_Det3D_ChessBd_NVer_value : U16 X64: number of Pixels of Vertically Surely NOT matching Chessboard pattern.
15:0	R.O	0x0	RO_Det3D_ChessBd_Ver_value : U16 X64: number of Pixels of Vertically Surely matching Chessboard pattern.

**Table 9-532 DET3D\_RO\_SPLT\_HT 0x173f**

Bit(s)	R/W	Default	Description
24	R.O	0x0	RO_Det3D_Split_HT_valid : U1 horizontal LR split border detected valid signal for top half picture
20:16	R.O	0x0	RO_Det3D_Split_HT_pxnum : U5 number of pixels included for the LR split position estimation for top half picture
9:0	R.O	0x0	RO_Det3D_Split_HT_idxX4 : S10 X4: horizontal pixel shifts of LR split position to the (ColMax/2) for top half picture

**Table 9-533 NR2\_MET\_NM\_CTRL 0x1745**

Bit(s)	R/W	Default	Description
28	R/W	0x0	reg_NM_reset : Reset to the status of the Loop filter.
27:24	R/W	0x0	reg_NM_calc_length : Length mode of the Noise measurement sample number for statistics. 0 : 256 samples; 1: 512 samples; 2: 1024 samples; $\bar{x}$ : $2^{(8+x)}$ samples
23:20	R/W	0x0	reg_NM_inc_step : Loop filter input gain increase step.
19:16	R/W	0x0	reg_NM_dec_step : Loop filter input gain decrease step.

Bit(s)	R/W	Default	Description
15:8	R/W	0x0	reg_NM_YHPmot_thr : Luma channel HP portion motion for condition of pixels included in Luma Noise measurement.
7:0	R/W	0x0	reg_NM_CHPmot_thr : Chroma channel HP portion motion for condition of pixels included in Chroma Noise measurement.

**Table 9-534 NR2\_MET\_NM\_YCTRL 0x1746**

Bit(s)	R/W	Default	Description
31:28	R/W	0x0	reg_NM_YPLL_target : Target rate of NM_Ynoise_thr to mean of the Luma Noise
27:24	R/W	0x0	reg_NM_YLPmot_thr : Luma channel LP portion motion for condition of pixels included in Luma Noise measurement.
23:16	R/W	0x0	reg_NM_YHPmot_thr_min : Minimum threshold for Luma channel HP portion motion to decide whether the pixel will be included in Luma noise measurement.
15:8	R/W	0x0	reg_NM_YHPmot_thr_max : Maximum threshold for Luma channel HP portion motion to decide whether the pixel will be included in Luma noise measurement.
7:0	R/W	0x0	reg_NM_Ylock_rate : Rate to decide whether the Luma noise measurement is lock or not.

**Table 9-535 NR2\_MET\_NM\_CCTRL 0x1747**

Bit(s)	R/W	Default	Description
31:28	R/W	0x0	reg_NM_CPPLL_target : Target rate of NM_Cnoise_thr to mean of the Chroma Noise
27:24	R/W	0x0	reg_NM_CLPmot_thr : Chroma channel LP portion motion for condition of pixels included in Chroma Noise measurement.
23:16	R/W	0x0	reg_NM_CHPmot_thr_min : Minimum threshold for Chroma channel HP portion motion to decide whether the pixel will be included in Chroma noise measurement.
15:8	R/W	0x0	reg_NM_CHPmot_thr_max : Maximum threshold for Chroma channel HP portion motion to decide whether the pixel will be included in Chroma noise measurement.
7:0	R/W	0x0	reg_NM_Clock_rate : Rate to decide whether the Chroma noise measurement is lock or not;

**Table 9-536 NR2\_MET\_NM\_TNR 0x1748**

Bit(s)	R/W	Default	Description
25	R.O	0x0	ro_NM_TNR_Ylock : Read-only register to tell if Luma channel noise measurement is locked or not.
24	R.O	0x0	ro_NM_TNR_Clock : Read-only register to tell if Chroma channel noise measurement is locked or not.
23:12	R.O	0x0	ro_NM_TNR_Ylevel : Read-only register to give Luma channel noise level. It was 16x of pixel difference in 8 bits of YHPmot.
11:0	R.O	0x0	ro_NM_TNR_Clevel : Read-only register to give Chroma channel noise level. It was 16x of pixel difference in 8 bits of CHPmot.

**Table 9-537 NR2\_MET\_NMFRM\_TNR\_YLEV 0x1749**

Bit(s)	R/W	Default	Description
28:0	R.O	0x0	ro_NMFrm_TNR_Ylevel : Frame based Read-only register to give Luma channel noise level within one frame/field.

**Table 9-538 NR2\_MET\_NMFRM\_TNR\_YCNT 0x174a**

Bit(s)	R/W	Default	Description
23:0	R.O	0x0	ro_NMFrm_TNR_Ycount : Number of Luma channel pixels included in Frame/Field based noise level measurement.

**Table 9-539 NR2\_MET\_NMFRM\_TNR\_CLEV 0x174b**

Bit(s)	R/W	Default	Description
28:0	R.O	0x0	ro_NMFrm_TNR_Clevel : Frame based Read-only register to give Chroma channel noise level within one frame/field.

**Table 9-540 NR2\_MET\_NMFRM\_TNR\_CCNT 0x174c**

Bit(s)	R/W	Default	Description
23:0	R.O	0x0	ro_NMFrm_TNR_Ccount : Number of Chroma channel pixels included in Frame/Field based noise level measurement.

**Table 9-541 NR2\_3DEN\_MODE 0x174d**

Bit(s)	R/W	Default	Description
6:4	R/W	0x0	Blend_3dnr_en_r :
2:0	R/W	0x0	Blend_3dnr_en_l :

**Table 9-542 NR2\_IIR\_CTRL 0x174e**

Bit(s)	R/W	Default	Description
15:14	R/W	0x0	reg_LP_IIR_8bit_mode : LP IIR membitwidth mode:0: 10bits will be store in memory;1: 9bits will be store in memory; 2 : 8bits will be store in memory;3: 7bits will be store in memory;
13:12	R/W	0x0	reg_LP_IIR_mute_mode : Mode for the LP IIR mute,
11:8	R/W	0x0	reg_LP_IIR_mute_thrd : Threshold of LP IIR mute to avoid ghost:
7:6	R/W	0x0	reg_HP_IIR_8bit_mode : IIR membitwidth mode:0: 10bits will be store in memory;1: 9bits will be store in memory; 2 : 8bits will be store in memory;3: 7bits will be store in memory;
5:4	R/W	0x0	reg_HP_IIR_mute_mode : Mode for theLP IIR mute
3:0	R/W	0x0	reg_HP_IIR_mute_thrd : Threshold of HP IIR mute to avoid ghost



Table 9-543 NR2\_SNR\_SAD\_CFG 0x1751

Bit(s)	R/W	Default	Description
12	R/W	0x1	reg_MATNR_SNR_SAD_CenRPL : U1, Enable signal for Current pixel position SAD to be replaced by SAD_min.0: do not replace Current pixel position SAD by SAD_min;1: do replacements
11:8	R/W	0x3	reg_MATNR_SNR_SAD_coring : Coring value of the intra-frame SAD. sum = (sum - reg_MATNR_SNR_SAD_coring);sum = (sum<0) ? 0: (sum>255)? 255: sum;
6:5	R/W	0x1	reg_MATNR_SNR_SAD_WinMod : Unsigned, Intra-frame SAD matching window mode:0: 1x1; 1: [1 1 1] 2: [1 2 1]; 3: [1 2 2 1];
4:0	R/W	0x1	Sad_coef_num : Sad coefficient

Table 9-544 NR2\_MATNR\_SNR\_OS 0x1752

Bit(s)	R/W	Default	Description
7:4	R/W	0x8	reg_MATNR_SNR_COS : SNR Filter overshoot control margin for UV channel (X2 to u10 scale)
3:0	R/W	0xd	reg_MATNR_SNR_YOS : SNR Filter overshoot control margin for luma channel (X2 to u10 scale)

Table 9-545 NR2\_MATNR\_SNR\_NRM\_CFG 0x1753

Bit(s)	R/W	Default	Description
23:16	R/W	0x40	reg_MATNR_SNR_NRM_ofst : Edge based SNR boosting normalization offset to SAD_max ;
15:8	R/W	0xff	reg_MATNR_SNR_NRM_max : Edge based SNR boosting normalization Max value
7:0	R/W	0x0	reg_MATNR_SNR_NRM_min : Edge based SNR boosting normalization Min value

Table 9-546 NR2\_MATNR\_SNR\_NRM\_GAIN 0x1754

Bit(s)	R/W	Default	Description
15:8	R/W	0x0	reg_MATNR_SNR_NRM_Cgain : Edge based SNR boosting normalization Gain for Chrm channel (norm 32 as 1)
7:0	R/W	0x20	reg_MATNR_SNR_NRM_Ygain : Edge based SNR boosting normalization Gain for Luma channel (norm 32 as 1)

Table 9-547 NR2\_MATNR\_SNR\_LPF\_CFG 0x1755

Bit(s)	R/W	Default	Description
23:16	R/W	0xc	reg_MATNR_SNR_LPF_SADmaxTH : U8, Threshold to SADmax to use TNRLPF to replace SNRLPF. i.e.if (SAD_max<reg_MATNR_SNR_LPF_SADmaxTH) SNRLPF_yuv[k] = TNRLPF_yuv[k]
13:11	R/W	0x2	reg_MATNR_SNR_LPF_Cmode : LPF based SNR filtering mode on CHRM channel: 0 : gradient LPF [1 1]/2; 1: gradient LPF [2 1 1]/4; 2: gradient LPF [3 3 2]/8; 3: gradient LPF [5 4 4 3]/16; 4 : TNRLPF; 5 : CurLPF3x3_yuv[]; 6: CurLPF3o3_yuv [] 7: CurLPF3x5_yuv[]

Bit(s)	R/W	Default	Description
10: 8	R/W	0x2	reg_MATNR_SNR_LPF_Ymode : LPF based SNR filtering mode on LUMA channel: 0 : gradient LPF //Bit [1 1]/2, 1: gradient LPF [2 1 1]/4; 2: gradient LPF [3 3 2]/8;3: gradient LPF [5 4 4 3]/16; 4 : TNRLPF; 5 : CurLPF3x3_yuv[]; 6: CurLPF3o3_yuv[] 7: CurLPF3x5_yuv[]
7:4	R/W	0x6	reg_MATNR_SNR_LPF_SADmin3TH : Offset threshold to SAD_min to Discard SAD_min3 corresponding pixel in LPF SNR filtering. (X8 to u8 scale)
3:0	R/W	0x4	reg_MATNR_SNR_LPF_SADmin2TH : Offset threshold to SAD_min to Discard SAD_min2 corresponding pixel in LPF SNR filtering. (X8 to u8 scale)

Table 9-548 NR2\_MATNR\_SNR\_USF\_GAIN 0x1756

Bit(s)	R/W	Default	Description
15:8	R/W	0x0	reg_MATNR_SNR_USF_Cgain : Un-sharp (HP) compensate back Chrm portion gain, (norm 64 as 1)
7:0	R/W	0x0	reg_MATNR_SNR_USF_Ygain : Un-sharp (HP) compensate back Luma portion gain, (norm 64 as 1)

Table 9-549 NR2\_MATNR\_SNR\_EDGE2B 0x1757

Bit(s)	R/W	Default	Description
15:8	R/W	0x80	reg_MATNR_SNR_Edge2Beta_ofst : U8, Offset for Beta based on Edge.
7:0	R/W	0x10	reg_MATNR_SNR_Edge2Beta_gain : U8. Gain to SAD_min for Beta based on Edge. (norm 16 as 1)

Table 9-550 NR2\_MATNR\_BETA\_EGAIN 0x1758

Bit(s)	R/W	Default	Description
15:8	R/W	0x20	reg_MATNR_CBeta_Egain : U8, Gain to Edge based Beta for Chrm channel. (normalized to 32 as 1)
7:0	R/W	0x20	reg_MATNR_YBeta_Egain : U8, Gain to Edge based Beta for Luma channel. (normalized to 32 as 1)

Table 9-551 NR2\_MATNR\_BETA\_BRT 0x1759

Bit(s)	R/W	Default	Description
31:28	R/W	0x0	reg_MATNR_beta_BRT_limt_hi : U4, Beta adjustment based on Brightness high side Limit. (X16 to u8 scale)
27:24	R/W	0x0	reg_MATNR_beta_BRT_slop_hi : U4, Beta adjustment based on Brightness high side slope. Normalized to 16 as 1
23:16	R/W	0xa0	reg_MATNR_beta_BRT_thrd_hi : U8, Beta adjustment based on Brightness high threshold.(u8 scale)
15:12	R/W	0x6	reg_MATNR_beta_BRT_limt_lo : U4, Beta adjustment based on Brightness low side Limit. (X16 to u8 scale)

Bit(s)	R/W	Default	Description
11:8	R/W	0x6	reg_MATNR_beta_BRT_slop_lo : U4, Beta adjustment based on Brightness low side slope. Normalized to 16 as 1
7:0	R/W	0x64	reg_MATNR_beta_BRT_thr_lo : U8, Beta adjustment based on Brightness low threshold.(u8 scale)

Table 9-552 NR2\_MATNR\_XBETA\_CFG 0x175a

Bit(s)	R/W	Default	Description
19:18	R/W	0x0	reg_MATNR_CBeta_use_mode : U2, Beta options (mux) from beta_motion and beta_edge for Chrm channel;
17:16	R/W	0x0	reg_MATNR_YBeta_use_mode : U2, Beta options (mux) from beta_motion and beta_edge for Luma channel;
15: 8	R/W	0x0	reg_MATNR_CBeta_Ofst : U8, Offset to Beta for Chrm channel.(after beta_edge and beta_motion mux)
7: 0	R/W	0x0	reg_MATNR_YBeta_Ofst : U8, Offset to Beta for Luma channel.(after beta_edge and beta_motion mux)

Table 9-553 NR2\_MATNR\_YBETA\_SCL 0x175b

Bit(s)	R/W	Default	Description
31:24	R/W	0x3c	reg_MATNR_YBeta_scale_min : U8, Final step Beta scale low limit for Luma channel;
23:16	R/W	0xff	reg_MATNR_YBeta_scale_max : U8, Final step Beta scale high limit for Luma channe;
15: 8	R/W	0x20	reg_MATNR_YBeta_scale_gain : U8, Final step Beta scale Gain for Luma channel (normalized 32 to 1);
7 : 0	R/W	0x0	reg_MATNR_YBeta_scale_ofst : S8, Final step Beta scale offset for Luma channel ;

Table 9-554 NR2\_MATNR\_CBETA\_SCL 0x175c

Bit(s)	R/W	Default	Description
31:24	R/W	0x0	reg_MATNR_CBeta_scale_min : Final step Beta scale low limit for Chrm channel.Similar to Y
23:16	R/W	0xff	reg_MATNR_CBeta_scale_max : U8, Final step Beta scale high limit for Chrm channel.Similar to Y
15: 8	R/W	0x20	reg_MATNR_CBeta_scale_gain : U8, Final step Beta scale Gain for Chrm channel Similar to Y
7: 0	R/W	0x0	reg_MATNR_CBeta_scale_ofst : S8, Final step Beta scale offset for Chrm channel Similar to Y

Table 9-555 NR2\_SNR\_MASK 0x175d

Bit(s)	R/W	Default	Description
20:0	R/W	0x0	SAD_MSK : Valid signal in the 3x7 SAD surface

**Table 9-556 NR2\_SAD2NORM\_LUT0 0x175e**

Bit(s)	R/W	Default	Description
31:24	R/W	0x72	reg_MATNR_SAD2Norm_LUT_3 : SAD convert normal LUT node 3
23:16	R/W	0x92	reg_MATNR_SAD2Norm_LUT_2 : SAD convert normal LUT node 2
15: 8	R/W	0xab	reg_MATNR_SAD2Norm_LUT_1 : SAD convert normal LUT node 1
7: 0	R/W	0xcd	reg_MATNR_SAD2Norm_LUT_0 : SAD convert normal LUT node 0

**Table 9-557 NR2\_SAD2NORM\_LUT1 0x175f**

Bit(s)	R/W	Default	Description
31:24	R/W	0x1c	reg_MATNR_SAD2Norm_LUT_7 : SAD convert normal LUT node 7
23:16	R/W	0x23	reg_MATNR_SAD2Norm_LUT_6 : SAD convert normal LUT node 6
15: 8	R/W	0x31	reg_MATNR_SAD2Norm_LUT_5 : SAD convert normal LUT node 5
7: 0	R/W	0x4f	reg_MATNR_SAD2Norm_LUT_4 : SAD convert normal LUT node 4

**Table 9-558 NR2\_SAD2NORM\_LUT2 0x1760**

Bit(s)	R/W	Default	Description
31:24	R/W	0xf	reg_MATNR_SAD2Norm_LUT_11 : SAD convert normal LUT node 11
23:16	R/W	0x11	reg_MATNR_SAD2Norm_LUT_10 : SAD convert normal LUT node 10
15: 8	R/W	0x13	reg_MATNR_SAD2Norm_LUT_9 : SAD convert normal LUT node 9
7: 0	R/W	0x17	reg_MATNR_SAD2Norm_LUT_8 : SAD convert normal LUT node 8

**Table 9-559 NR2\_SAD2NORM\_LUT3 0x1761**

Bit(s)	R/W	Default	Description
31:24	R/W	0x8	reg_MATNR_SAD2Norm_LUT_15 : SAD convert normal LUT node 15
23:16	R/W	0x9	reg_MATNR_SAD2Norm_LUT_14 : SAD convert normal LUT node 14
15:8	R/W	0xa	reg_MATNR_SAD2Norm_LUT_13 : SAD convert normal LUT node 13
7:0	R/W	0xc	reg_MATNR_SAD2Norm_LUT_12 : SAD convert normal LUT node 12

**Table 9-560 NR2\_EDGE2BETA\_LUT0 0x1762**

Bit(s)	R/W	Default	Description
31:24	R/W	0x80	reg_MATNR_Edge2Beta_LUT_3 : Edge convert beta LUT node 3
23:16	R/W	0xa0	reg_MATNR_Edge2Beta_LUT_2 : Edge convert beta LUT node 2
15: 8	R/W	0xe0	reg_MATNR_Edge2Beta_LUT_1 : Edge convert beta LUT node 1
7: 0	R/W	0xff	reg_MATNR_Edge2Beta_LUT_0 : Edge convert beta LUT node 0

**Table 9-561 NR2\_EDGE2BETA\_LUT1 0x1763**

Bit(s)	R/W	Default	Description
31:24	R/W	0x4	reg_MATNR_Edge2Beta_LUT_7 : Edge convert beta LUT node 7
23:16	R/W	0x10	reg_MATNR_Edge2Beta_LUT_6 : Edge convert beta LUT node 6
15: 8	R/W	0x20	reg_MATNR_Edge2Beta_LUT_5 : Edge convert beta LUT node 5
7: 0	R/W	0x50	reg_MATNR_Edge2Beta_LUT_4 : Edge convert beta LUT node 4

**Table 9-562 NR2\_EDGE2BETA\_LUT2 0x1a64**

Bit(s)	R/W	Default	Description
31:24	R/W	0x0	reg_MATNR_Edge2Beta_LUT_11 : Edge convert beta LUT node 11
23:16	R/W	0x0	reg_MATNR_Edge2Beta_LUT_10 : Edge convert beta LUT node 10
15: 8	R/W	0x0	reg_MATNR_Edge2Beta_LUT_9 : Edge convert beta LUT node 9
7: 0	R/W	0x2	reg_MATNR_Edge2Beta_LUT_8 : Edge convert beta LUT node 8

**Table 9-563 NR2\_EDGE2BETA\_LUT3 0x1765**

Bit(s)	R/W	Default	Description
31:24	R/W	0x0	reg_MATNR_Edge2Beta_LUT_15 : Edge convert beta LUT node 15
23:16	R/W	0x0	reg_MATNR_Edge2Beta_LUT_14 : Edge convert beta LUT node 14
15: 8	R/W	0x0	reg_MATNR_Edge2Beta_LUT_13 : Edge convert beta LUT node 13
7: 0	R/W	0x0	reg_MATNR_Edge2Beta_LUT_12 : Edge convert beta LUT node 12

**Table 9-564 NR2\_MOTION2BETA\_LUT0 0x1766**

Bit(s)	R/W	Default	Description
31:24	R/W	0x20	reg_MATNR_Mot2Beta_LUT_3 : Motion convert beta LUT node 3
23:16	R/W	0x10	reg_MATNR_Mot2Beta_LUT_2 : Motion convert beta LUT node 2
15: 8	R/W	0x4	reg_MATNR_Mot2Beta_LUT_1 : Motion convert beta LUT node 1
7: 0	R/W	0x0	reg_MATNR_Mot2Beta_LUT_0 : Motion convert beta LUT node 0

**Table 9-565 NR2\_MOTION2BETA\_LUT1 0x1767**

Bit(s)	R/W	Default	Description
31:24	R/W	0xc4	reg_MATNR_Mot2Beta_LUT_7 : Motion convert beta LUT node 7
23:16	R/W	0x80	reg_MATNR_Mot2Beta_LUT_6 : Motion convert beta LUT node 6
15: 8	R/W	0x40	reg_MATNR_Mot2Beta_LUT_5 : Motion convert beta LUT node 5
7: 0	R/W	0x30	reg_MATNR_Mot2Beta_LUT_4 : Motion convert beta LUT node 4

**Table 9-566 NR2\_MOTION2BETA\_LUT2 0x1768**

Bit(s)	R/W	Default	Description
31:24	R/W	0xff	reg_MATNR_Mot2Beta_LUT_11 : Motion convert beta LUT node 11
23:16	R/W	0xff	reg_MATNR_Mot2Beta_LUT_10 : Motion convert beta LUT node 10
15: 8	R/W	0xf0	reg_MATNR_Mot2Beta_LUT_9 : Motion convert beta LUT node 9
7: 0	R/W	0xe0	reg_MATNR_Mot2Beta_LUT_8 : Motion convert beta LUT node 8

**Table 9-567 NR2\_MOTION2BETA\_LUT3 0x1769**

Bit(s)	R/W	Default	Description
31:24	R/W	0xff	reg_MATNR_Mot2Beta_LUT_15 : Motion convert beta LUT node 15
23:16	R/W	0xff	reg_MATNR_Mot2Beta_LUT_14 : Motion convert beta LUT node 14
15: 8	R/W	0xff	reg_MATNR_Mot2Beta_LUT_13 : Motion convert beta LUT node 13
7: 0	R/W	0xff	reg_MATNR_Mot2Beta_LUT_12 : Motion convert beta LUT node 12

**Table 9-568 NR2\_MATNR\_MTN\_CTRL 0x176a**

Bit(s)	R/W	Default	Description
25:24	R/W	0x0	reg_MATNR_Vmtm_use_mode : Motion_yuvV channel motion selection mode:0: Vmot;1:Ymot/2 + (Umot+Vmot)/4; 2:Ymot/2 + max(Umot,Vmot)/2; 3: max(Ymot, Umot, Vmot)
21:20	R/W	0x0	reg_MATNR_Umtm_use_mode : Motion_yuvU channel motion selection mode:0: Umot;1:Ymot/2 + (Umot+Vmot)/4; 2:Ymot/2 + max(Umot,Vmot)/2; 3: max(Ymot, Umot, Vmot)
17:16	R/W	0x0	reg_MATNR_Ymtm_use_mode : Motion_yuvLuma channel motion selection mode:0: Ymot, 1: Ymot/2 + (Umot+Vmot)/4; 2: Ymot/2 + max(Umot,Vmot)/2; 3: max(Ymot,Umot, Vmot)
13:12	R/W	0x1	reg_MATNR_mtn_txt_mode : Texture detection mode for adaptive coring of HP motion
9: 8	R/W	0x1	reg_MATNR_mtn_cor_mode : Coring selection mode based on texture detection;
6: 4	R/W	0x8	reg_MATNR_mtn_hpf_mode : video mode of current and previous frame/field for MotHPF_yuv[k] calculation:
2: 0	R/W	0x6	reg_MATNR_mtn_lpf_mode : LPF video mode of current and previous frame/field for MotLPF_yuv[k] calculation:

**Table 9-569 NR2\_MATNR\_MTN\_CTRL2 0x176b**

Bit(s)	R/W	Default	Description
18:16	R/W	0x6	reg_MATNR_iir_BS_Ymode : IIR TNR filter Band split filter mode for Luma LPF result generation (Cur and Prev);
15: 8	R/W	0x40	reg_MATNR_mtnb_alpLP_Cgain : Scale of motion_brthp_uv to motion_brthp_uv, normalized to 32 as 1
7: 0	R/W	0x40	reg_MATNR_mtnb_alpLP_Ygain : Scale of motion_brthp_y to motion_brthp_y, normalized to 32 as 1

**Table 9-570 NR2\_MATNR\_MTN\_COR 0x176c**

Bit(s)	R/W	Default	Description
15:12	R/W	0x3	reg_MATNR_mtn_cor_Cofst : Coring Offset for Chroma Motion.
11: 8	R/W	0x3	reg_MATNR_mtn_cor_Cgain : Gain to texture based coring for Chroma Motion. Normalized to 16 as 1
7: 4	R/W	0x3	reg_MATNR_mtn_cor_Yofst : Coring Offset for Luma Motion.
3: 0	R/W	0x3	reg_MATNR_mtn_cor_Ygain : Gain to texture based coring for Luma Motion. Normalized to 16 as 1

**Table 9-571 NR2\_MATNR\_MTN\_GAIN 0x176d**

Bit(s)	R/W	Default	Description
31:24	R/W	0x40	reg_MATNR_mtn_hp_Cgain : Gain to MotHPF_yuv[k] Chrm channel for motion calculation, normalized to 64 as 1
23:16	R/W	0x40	reg_MATNR_mtn_hp_Ygain : Gain to MotHPF_yuv[k] Luma channel for motion calculation, normalized to 64 as 1
15: 8	R/W	0x40	reg_MATNR_mtn_lp_Cgain : Gain to MotLPF_yuv[k] Chrm channel for motion calculation, normalized to 32 as 1
7: 0	R/W	0x40	reg_MATNR_mtn_lp_Ygain : Gain to MotLPF_yuv[k] Luma channel for motion calculation, normalized to 32 as 1

**Table 9-572 NR2\_MATNR\_DEGHOST 0x176e**

Bit(s)	R/W	Default	Description
30:28	R/W	0	reg_matnr_deghost_mode : // unsigned , default = 0 0:old_deghost; 1:soft_denoise & strong_deghost; 2:strong_denoise & soft_deghost; 3:strong_denoise & strong_deghost
24:20	R/W	4	reg_matnr_deghost_ygain : // unsigned , default = 4
16:12	R/W	4	reg_matnr_deghost_cgain : // unsigned , default = 4
8	R/W	1	reg_matnr_deghost_en : // unsigned , default = 1 0: disable; 1: enable Enable signal for DeGhost function:0: disable; 1: enable
7: 4	R/W	3	reg_matnr_deghost_cos : // unsigned , default = 3 DeGhost Overshoot margin for UV channel, (X2 to u10 scale)
3: 0	R/W	3	reg_matnr_deghost_yos : // unsigned , default = 3 DeGhost Overshoot margin for Luma channel, (X2 to u10 scale)

**Table 9-573 NR2\_MATNR\_ALPHA\_LP\_LUT0 0x176f**

Bit(s)	R/W	Default	Description
31:24	R/W	0x40	reg_MATNR_AlphaLP_LUT_3 : Matnr low-pass filter alpha LUT node 3
23:16	R/W	0x80	reg_MATNR_AlphaLP_LUT_2 : Matnr low-pass filter alpha LUT node 2
15: 8	R/W	0x80	reg_MATNR_AlphaLP_LUT_1 : Matnr low-pass filter alpha LUT node 1
7: 0	R/W	0x80	reg_MATNR_AlphaLP_LUT_0 : Matnr low-pass filter alpha LUT node 0

**Table 9-574 NR2\_MATNR\_ALPHA\_LP\_LUT1 0x1770**

Bit(s)	R/W	Default	Description
31:24	R/W	0xff	reg_MATNR_AlphaLP_LUT_7 : Matnr low-pass filter alpha LUT node 7
23:16	R/W	0x80	reg_MATNR_AlphaLP_LUT_6 : Matnr low-pass filter alpha LUT node 6
15: 8	R/W	0x50	reg_MATNR_AlphaLP_LUT_5 : Matnr low-pass filter alpha LUT node 5
7: 0	R/W	0x40	reg_MATNR_AlphaLP_LUT_4 : Matnr low-pass filter alpha LUT node 4

**Table 9-575 NR2\_MATNR\_ALPHA\_LP\_LUT2 0x1771**

Bit(s)	R/W	Default	Description
31:24	R/W	0xff	reg_MATNR_AlphaLP_LUT_11 : Matnr low-pass filter alpha LUT node 11
23:16	R/W	0xff	reg_MATNR_AlphaLP_LUT_10 : Matnr low-pass filter alpha LUT node 10
15: 8	R/W	0xff	reg_MATNR_AlphaLP_LUT_9 : Matnr low-pass filter alpha LUT node 9
7: 0	R/W	0xff	reg_MATNR_AlphaLP_LUT_8 : Matnr low-pass filter alpha LUT node 8

**Table 9-576 NR2\_MATNR\_ALPHA\_LP\_LUT3 0x1772**

Bit(s)	R/W	Default	Description
31:24	R/W	0xff	reg_MATNR_AlphaLP_LUT_15 : Matnr low-pass filter alpha LUT node 15
23:16	R/W	0xff	reg_MATNR_AlphaLP_LUT_14 : Matnr low-pass filter alpha LUT node 14
15: 8	R/W	0xff	reg_MATNR_AlphaLP_LUT_13 : Matnr low-pass filter alpha LUT node 13
7: 0	R/W	0xff	reg_MATNR_AlphaLP_LUT_12 : Matnr low-pass filter alpha LUT node 12

**Table 9-577 NR2\_MATNR\_ALPHA\_HP\_LUT0 0x1773**

Bit(s)	R/W	Default	Description
31:24	R/W	0x40	reg_MATNR_AlphaHP_LUT_3 : Matnr high-pass filter alpha LUT node 3
23:16	R/W	0x80	reg_MATNR_AlphaHP_LUT_2 : Matnr high-pass filter alpha LUT node 2
15: 8	R/W	0x80	reg_MATNR_AlphaHP_LUT_1 : Matnr high-pass filter alpha LUT node 1
7: 0	R/W	0x80	reg_MATNR_AlphaHP_LUT_0 : Matnr high-pass filter alpha LUT node 0

**Table 9-578 NR2\_MATNR\_ALPHA\_HP\_LUT1 0x1774**

Bit(s)	R/W	Default	Description
31:24	R/W	0xff	reg_MATNR_AlphaHP_LUT_7 : Matnr high-pass filter alpha LUT node 7
23:16	R/W	0x80	reg_MATNR_AlphaHP_LUT_6 : Matnr high-pass filter alpha LUT node 6
15: 8	R/W	0x50	reg_MATNR_AlphaHP_LUT_5 : Matnr high-pass filter alpha LUT node 5
7: 0	R/W	0x40	reg_MATNR_AlphaHP_LUT_4 : Matnr high-pass filter alpha LUT node 4



**Table 9-579 NR2\_MATNR\_ALPHAHP\_LUT2 0x1775**

Bit(s)	R/W	Default	Description
31:24	R/W	0xff	reg_MATNR_AlphaHP_LUT_11 : Matnr high-pass filter alpha LUT node 11
23:16	R/W	0xff	reg_MATNR_AlphaHP_LUT_10 : Matnr high-pass filter alpha LUT node 10
15: 8	R/W	0xff	reg_MATNR_AlphaHP_LUT_9 : Matnr high-pass filter alpha LUT node 9
7: 0	R/W	0xff	reg_MATNR_AlphaHP_LUT_8 : Matnr high-pass filter alpha LUT node 8

**Table 9-580 NR2\_MATNR\_ALPHAHP\_LUT3 0x1776**

Bit(s)	R/W	Default	Description
31:24	R/W	0xff	reg_MATNR_AlphaHP_LUT_15 : Matnr high-pass filter alpha LUT node 15
23:16	R/W	0xff	reg_MATNR_AlphaHP_LUT_14 : Matnr high-pass filter alpha LUT node 14
15: 8	R/W	0xff	reg_MATNR_AlphaHP_LUT_13 : Matnr high-pass filter alpha LUT node 13
7: 0	R/W	0xff	reg_MATNR_AlphaHP_LUT_12 : Matnr high-pass filter alpha LUT node 12

**Table 9-581 NR2\_MATNR\_MTNB\_BRT 0x1777**

Bit(s)	R/W	Default	Description
31:28	R/W	0x0	reg_MATNR_mtnb_BRT_limt_hi : Motion adjustment based on Brightness high side Limit. (X16 to u8 scale)
27:24	R/W	0x0	reg_MATNR_mtnb_BRT_slop_hi : Motion adjustment based on Brightness high side slope. Normalized to 16 as 1
23:16	R/W	0xa0	reg_MATNR_mtnb_BRT_thr_d_hi : Motion adjustment based on Brightness high threshold.(u8 scale)
15:12	R/W	0x6	reg_MATNR_mtnb_BRT_limt_lo : Motion adjustment based on Brightness low side Limit. (X16 to u8 scale)
11: 8	R/W	0x6	reg_MATNR_mtnb_BRT_slop_lo : Motion adjustment based on Brightness low side slope. Normalized to 16 as 1
7: 0	R/W	0x64	reg_MATNR_mtnb_BRT_thr_d_lo : Motion adjustment based on Brightness low threshold.(u8 scale)

**Table 9-582 NR2\_CUE\_MODE 0x1778**

Bit(s)	R/W	Default	Description
31:20	R/W	0x0	Reserved
19	R/W	0x0	Cue2_isabv_org_invert1
18	R/W	0x1	Cue2_valid_condition
17:16	R/W	0x1	Cue2_orgline_ft_sel
15:12	R/W	0x4	Cue2_orgline_ft_alph
11	R/W	0x0	Cue2_isabv_org_invert
10	R/W	0x0	Cue2_iscur_org_invert
9	R/W	0x0	Cue_enable_r : Cue right half frame enable

Bit(s)	R/W	Default	Description
8	R/W	0x0	Cue_enable_l : Cue left half frame enable
6:4	R/W	0x0	reg_CUE_CON_RPLC_mode : U3, CUE pixel chroma replace mode;
3:0	R/W	0x0	reg_CUE_CHRM_FLT_mode : U4, CUE improvement filter mode,

Table 9-583 NR2\_CUE\_CON\_MOT\_TH 0x1779

Bit(s)	R/W	Default	Description
31:24	R/W	0x0	reg_CUE_CON_Cmot_thrd2 : U8, Motion Detection threshold of up/down two rows, Chroma channel in Chroma Up-sampling Error (CUE) Detection (tighter).
23:16	R/W	0x0	reg_CUE_CON_Ymot_thrd2 : U8, Motion Detection threshold of up/mid/down three rows, Luma channel in Chroma Up-sampling Error (CUE) Detection (tighter).
15: 8	R/W	0x0	reg_CUE_CON_Cmot_thrd : U8, Motion Detection threshold of up/down two rows, Chroma channel in Chroma Up-sampling Error (CUE) Detection.
7: 0	R/W	0x0	reg_CUE_CON_Ymot_thrd : U8, Motion Detection threshold of up/mid/down three rows, Luma channel in Chroma Up-sampling Error (CUE) Detection.

Table 9-584 NR2\_CUE\_CON\_DIF0 0x177a

Bit(s)	R/W	Default	Description
15:8	R/W	0x0	reg_CUE_CON_diffP1_thrd : U8, P1 field Intra-Field top/below line chroma difference threshold,
7:0	R/W	0x0	reg_CUE_CON_diffCur_thrd : U8, Current Field/Frame Intra-Field up/down line chroma difference threshold,

Table 9-585 NR2\_CUE\_CON\_DIF1 0x177b

Bit(s)	R/W	Default	Description
19:16	R/W	0x0	reg_CUE_CON_rate0 : U4, The Krate to decide CUE by relationship between CUE_diffG and CUE_diffEG
15: 8	R/W	0x0	reg_CUE_CON_diffEG_thrd : U8, Theshold to the difference between current Field/Frame middle line to down line color channel(CUE_diffEG).
7: 0	R/W	0x0	reg_CUE_CON_diffG_thrd : U8, Threshold to the difference between P1 field top line to current Field/Frame down line color channel (CUE_diffG).

Table 9-586 NR2\_CUE\_CON\_DIF2 0x177c

Bit(s)	R/W	Default	Description
19:16	R/W	0x0	reg_CUE_CON_rate1 : U4, The Krate to decide CUE by relationship between CUE_diffnC and CUE_diffEC
15: 8	R/W	0x0	reg_CUE_CON_diffEC_thrd : U8, Theshold to the difference between current Field/Frame middle line to up line color channel(CUE_diffEC).
7: 0	R/W	0x0	reg_CUE_CON_diffnC_thrd : U8, Threshold to the difference between P1 field bot line to current Field/Frame up line color channel (CUE_diffnC).

**Table 9-587 NR2\_CUE\_CON\_DIF3 0x177d**

Bit(s)	R/W	Default	Description
19:16	R/W	0x0	reg_CUE_CON_rate2 : U4, The Krate to decide CUE by relationship between CUE_difP1 and CUE_difEP1
15: 8	R/W	0x0	reg_CUE_CON_difEP1_thrd : U8, Inter-Field top/below line to current field/frame middle line chroma difference (CUE_difEP1) threshold.
7: 0	R/W	0x0	reg_CUE_CON_difP1_thrd2 : U8, P1 field Intra-Field top/below line chroma difference threshold (tighter),

**Table 9-588 NR2\_CUE\_PRG\_DIF 0x177e**

Bit(s)	R/W	Default	Description
20	R/W	0x0	reg_CUE_PRG_Enable : Enable bit for progressive video CUE detection. If interlace input video,
19:16	R/W	0x0	reg_CUE_PRG_rate : U3, The Krate to decide CUE by relationship between CUE_difCur and (CUE_difEC+CUE_difEG)
15: 8	R/W	0x0	reg_CUE_PRG_difCEG_thrd : U8, Current Frame Intra-Field up-mid and mid-down line chroma difference threshold for progressive video CUE detection,
7: 0	R/W	0x0	reg_CUE_PRG_difCur_thrd : U8, Current Frame Intra-Field up/down line chroma difference threshold,

**Table 9-589 NR2\_CONV\_MODE 0x177f**

Bit(s)	R/W	Default	Description
3:2	R/W	0x0	Conv_c444_mode : The format convert mode about 422 to 444 when data read out line buffer
1:0	R/W	0x0	Conv_c422_mode : the format convert mode about 444 to 422 when data write to line buffer

DET 3D REG DEFINE BEGIN //// 8'h80~8'h8f

**Table 9-590 DET3D\_RO\_SPLIT\_HB 0x1780**

Bit(s)	R/W	Default	Description
24	R.O	0x0	RO_Det3D_Split_HB_valid : U1 horizontal LR split border detected valid signal for top half picture
20:16	R.O	0x0	RO_Det3D_Split_HB_pxnum : U5 number of pixels included for the LR split position estimation for top half picture
9: 0	R.O	0x0	RO_Det3D_Split_HB_idxX4 : S10 X4: horizontal pixel shifts of LR split position to the (ColMax/2) for top half picture

**Table 9-591 DET3D\_RO\_SPLIT\_VL 0x1781**

Bit(s)	R/W	Default	Description
24	R.O	0x0	RO_Det3D_Split_VL_valid : U1 horizontal LR split border detected valid signal for top half picture
20:16	R.O	0x0	RO_Det3D_Split_VL_pxnum : U5 number of pixels included for the LR split position estimation for top half picture
9: 0	R.O	0x0	RO_Det3D_Split_VL_idxX4 : S10 X4: horizontal pixel shifts of LR split position to the (ColMax/2) for top half picture

**Table 9-592 DET3D\_RO\_SPLIT\_VR 0x1782**

Bit(s)	R/W	Default	Description
24	R.O	0x0	RO_Det3D_Split_VR_valid : U1 horizontal LR split border detected valid signal for top half picture
20:16	R.O	0x0	RO_Det3D_Split_VR_pxnum : U5 number of pixels included for the LR split position estimation for top half picture
9: 0	R.O	0x0	RO_Det3D_Split_VR_idxX4 : S10 X4: horizontal pixel shifts of LR split position to the (ColMax/2) for top half picture

**Table 9-593 DET3D\_RO\_MAT\_LUMA\_LR 0x1783**

Bit(s)	R/W	Default	Description
15:0	R.O	0x0	RO_Luma_LR_score : S2*8 LUMA statistics left right decision score for each band (8bands vertically), it can be -1/0/1:-1: most likely not LR symmetric 0: not sure 1: most likely LR symmetric
7:0	R.O	0x0	RO_Luma_LR_symtc : U1*8 Luma statistics left right pure symmetric for each band (8bands vertically), it can be 0/1: 0: not sure 1: most likely LR is pure symmetric
4:0	R.O	0x0	RO_Luma_LR_sum : S5 Total score of 8x8 Luma statistics for LR like decision, the larger this score, the more confidence that this is a LR 3D video. It is sum of RO_Luma_LR_score[0~7]

**Table 9-594 DET3D\_RO\_MAT\_LUMA\_TB 0x1784**

Bit(s)	R/W	Default	Description
15:0	R.O	0x0	RO_Luma_TB_score : S2*8 LUMA statistics Top/Bottom decision score for each band (8bands Horizontally),
7:0	R.O	0x0	RO_Luma_TB_symtc : Luma statistics Top/Bottom pure symmetric for each band (8bands Horizontally),
4:0	R.O	0x0	RO_Luma_TB_sum : Total score of 8x8 Luma statistics for TB like decision,

**Table 9-595 DET3D\_RO\_MAT\_CHRU\_LR 0x1785**

Bit(s)	R/W	Default	Description
15:0	R.O	0x0	RO_ChrU_LR_score : S2*8 LUMA statistics left right decision score for each band (8bands vertically),
7:0	R.O	0x0	RO_ChrU_LR_symtc : CHRU statistics left right pure symmetric for each band (8bands vertically),
4:0	R.O	0x0	RO_ChrU_LR_sum : Total score of 8x8 ChrU statistics for LR like decision,

**Table 9-596 DET3D\_RO\_MAT\_CHRU\_TB 0x1786**

Bit(s)	R/W	Default	Description
15:0	R.O	0x0	RO_ChrU_TB_score : S2*8 CHRU statistics Top/Bottom decision score for each band (8bands Horizontally)
7:0	R.O	0x0	RO_ChrU_TB_symtc : CHRU statistics Top/Bottom pure symmetric for each band (8bands Horizontally)
4:0	R.O	0x0	RO_ChrU_TB_sum : Total score of 8x8 ChrU statistics for TB like decision

**Table 9-597 DET3D\_RO\_MAT\_CHRV\_LR 0x1787**

Bit(s)	R/W	Default	Description
15:0	R.O	0x0	RO_ChrV_LR_score : S2*8 CHRU statistics left right decision score for each band (8bands vertically)
7:0	R.O	0x0	RO_ChrV_LR_symtc : CHRv statistics left right pure symmetric for each band (8bands vertically)
4:0	R.O	0x0	RO_ChrV_LR_sum : Total score of 8x8 ChrV statistics for LR like decision

**Table 9-598 DET3D\_RO\_MAT\_CHRV\_TB 0x1788**

Bit(s)	R/W	Default	Description
15:0	R.O	0x0	RO_ChrV_TB_score : CHRv statistics Top/Bottom decision score for each band (8bands Horizontally)
7:0	R.O	0x0	RO_ChrV_TB_symtc : CHRv statistics Top/Bottom pure symmetric for each band (8bands Horizontally)
4:0	R.O	0x0	RO_ChrV_TB_sum : Total score of 8x8 ChrV statistics for TB like decision

**Table 9-599 DET3D\_RO\_MAT\_HEDG\_LR 0x1789**

Bit(s)	R/W	Default	Description
15:0	R.O	0x0	RO_Hedg_LR_score : Horizontal Edge statistics left right decision score for each band (8bands vertically)
7:0	R.O	0x0	RO_Hedg_LR_symtc : Horizontal Edge statistics left right pure symmetric for each band (8bands vertically)
4:0	R.O	0x0	RO_Hedg_LR_sum : Total score of 8x8 Hedg statistics for LR like decision

**Table 9-600 DET3D\_RO\_MAT\_HEDG\_TB 0x178a**

Bit(s)	R/W	Default	Description
15:0	R.O	0x0	RO_Hedg_TB_score : Horizontal Edge statistics Top/Bottom decision score for each band (8bands Horizontally)
7:0	R.O	0x0	RO_Hedg_TB_symtc : Horizontal Edge statistics Top/Bottom pure symmetric for each band (8bands Horizontally)
4:0	R.O	0x0	RO_Hedg_TB_sum : Total score of 8x8 Hedg statistics for TB like decision

**Table 9-601 DET3D\_RO\_MAT\_VEDG\_LR 0x178b**

Bit(s)	R/W	Default	Description
15:0	R.O	0x0	RO_Vedg_LR_score : Vertical Edge statistics left right decision score for each band (8bands vertically)
7:0	R.O	0x0	RO_Vedg_LR_symtc : Vertical Edge statistics left right pure symmetric for each band (8bands vertically)
4:0	R.O	0x0	RO_Vedg_LR_sum : Total score of 8x8 Vedg statistics for LR like decision

**Table 9-602 DET3D\_RO\_MAT\_VEDG\_TB 0x178c**

Bit(s)	R/W	Default	Description
15:0	R.O	0x0	RO_Vedg_TB_score : Vertical Edge statistics Top/Bottom decision score for each band (8bands Horizontally)
7:0	R.O	0x0	RO_Vedg_TB_symtc : Vertical Edge statistics Top/Bottom pure symmetric for each band (8bands Horizontally)
4:0	R.O	0x0	RO_Vedg_TB_sum : Total score of 8x8 Vedg statistics for TB like decision

**Table 9-603 DET3D\_RO\_MAT\_MOTN\_LR 0x178d**

Bit(s)	R/W	Default	Description
15:0	R.O	0x0	RO_Motn_LR_score : Motion statistics left right decision score for each band (8bands vertically)
7:0	R.O	0x0	RO_Motn_LR_symtc : Motion statistics left right pure symmetric for each band (8bands vertically)
4:0	R.O	0x0	RO_Motn_LR_sum : Total score of 8x8 Motion statistics for LR like decision

**Table 9-604 DET3D\_RO\_MAT\_MOTN\_TB 0x178e**

Bit(s)	R/W	Default	Description
15:0	R.O	0x0	RO_Motn_TB_score : Motion statistics Top/Bottom decision score for each band (8bands Horizontally)
7:0	R.O	0x0	RO_Motn_TB_symtc : Motion statistics Top/Bottom pure symmetric for each band (8bands Horizontally)
4:0	R.O	0x0	RO_Motn_TB_sum : Total score of 8x8 Motion statistics for TB like decision

**Table 9-605 DET3D\_RO\_FRM\_MOTN 0x178f**

Bit(s)	R/W	Default	Description
15:0	R.O	0x0	RO_Det3D_Frame_Motion : U16 frame based motion value sum for still image decision in FW. mat ram read enter addr

DET3D\_RAMRD\_ADDR\_PORT 0x179a

DET3D\_RAMRD\_DATA\_PORT 0x179b

**Table 9-606 NR2\_CFR\_PARA\_CFG0 0x179c**

Bit(s)	R/W	Default	Description
8	R/W	0x0	reg_CFR_CurDif_luma_mode : Current Field Top/Bot line Luma difference calculation mode
7:6	R/W	0x0	reg_MACFR_frm_phase : U2 This will be a field based phase register that need to be set by FW phase to phase: this will be calculated based on dbdr_phase of the specific line of this frame. u1 : dbdr_phase=1, center line is DB in current line; dbdr_phase=2, center line is Dr in current line;
5:4	R/W	0x0	reg_CFR_CurDif_tran_mode : U2 Current Field Top/Bot line Luma/Chroma transition level calculation mode,
3:2	R/W	0x0	reg_CFR_alpha_mode : U2 Alpha selection mode for CFR block from curAlp and motAlp i.e. 0: motAlp; 1: (motAlp+curAlp)/2; 2: min(motAlp,curAlp); 3: max(motAlp,curAlp);
1:0	R/W	0x0	reg_CFR_Motion_Luma_mode : U2 LumaMotion Calculation mode for MA-CFR. 0: top/bot Lumma motion; 1: middle Luma Motion 2: top/bot + middle motion; 3: max(top/tot motion, middle motion)

**Table 9-607 NR2\_CFR\_PARA\_CFG1 0x179d**

Bit(s)	R/W	Default	Description
23:16	R/W	0x0	reg_CFR_alpha_gain : gain to map muxed curAlp and motAlp to alpha that will be used for final blending.
15: 8	R/W	0x0	reg_CFR_Motion_ofst : Offset to Motion to calculate the motAlp, e.g: motAlp= reg_CFR_Motion_ofst- Motion; This register can be seen as the level of motion that we consider it at moving.
7: 0	R/W	0x0	reg_CFR_CurDif_gain : gain to CurDif to map to alpha, normalized to 32;

**Table 9-608 NR3\_MODE 0x2ff0**

Bit(s)	R/W	Default	Description
5	R/W	0x0	reg_3dnr_nr3_vtxt_mode : ;
4	R/W	0x0	reg_3dnr_nr3_cbyy_ignor_coop : ; // u1: ignore coop condition for cbyy motion decision
3	R/W	0x0	reg_3dnr_nr3_ybyc_ignor_cnoop : ; // u1: ignore cnoop condition for ybyc motion decision
2:0	R/W	0x3	reg_3dnr_nr3_suremot_txt_mode : ; // u3: 0: cur, 1:p2; 2: (cur+p2)/2; 3/up: min (cur,p2)

Table 9-609 NR3\_COOP\_PARA 0x2ff1

Bit(s)	R/W	Default	Description
21:20	R/W	0x2	reg_3dnr_nr3_coop_mode : ; // u2 0 original pixel 1: [1 2 1]/4 lpf; 2: [1 2 2 1]/8; 3: 3x3 lpf
19:16	R/W	0x8	reg_3dnr_nr3_coop_ratio : ; // u4 cur and p2 color oop decision ratio: (avg1<(MAX(sat0,sat2)*ratio/8 + ofst));
15:8	R/W	0x0	reg_3dnr_nr3_coop_ofset : ; // s8 cur and p2 color oop decision ofst: (avg1<(MAX(sat0,sat2)*ratio/8 + ofst));
7:0	R/W	0x0	reg_3dnr_nr3_coop_sat_thrd : ; // u8 cur and p2 color oop decision min(sat0, sat1) threshold;

Table 9-610 NR3\_CNOOP\_GAIN 0x2ff2

Bit(s)	R/W	Default	Description
23:20	R/W	0x8	reg_3dnr_nr3_cnoop_ratio0 : ; // u4 cur and p2 color noop decision ratio0: (avg1<(MAX(sat0,sat2)*ratio0/8 + ofst0));
19:16	R/W	0x8	reg_3dnr_nr3_cnoop_ratio1 : ; // u4 cur and p2 color noop decision ratio1: (dif1<(MIN(sat0,sat2)*ratio1/8 + ofst1));
15:8	R/W	0x19	reg_3dnr_nr3_cnoop_ofset0 : ; // s8 cur and p2 color noop decision ofset0: (avg1<(MAX(sat0,sat2)*ratio0/8 + ofst0));
7:0	R/W	0x0	reg_3dnr_nr3_cnoop_ofset1 : ; // s8 cur and p2 color noop decision ofset1: (dif1<(MIN(sat0,sat2)*ratio1/8 + ofst1));

Table 9-611 NR3\_YMOT\_PARA 0x2ff3

Bit(s)	R/W	Default	Description
19	R/W	0x1	reg_3dnr_nr3_ymot_only_en : ; // u1: enable signal for ignor chroma motion: (ytxt )
18	R/W	0x1	reg_3dnr_nr3_ymot_only_cmtmode : ; // u1: 0: cmot=ymot; 1: cmot = MIN(ymot, cmot)
17:16	R/W	0x0	reg_3dnr_nr3_ymot_only_txtmode : ; // u2: 0, min(txt0,txt2); 1, max(txt0,txt2);2, (txt0+txt2)/2; 3: sat(txt0, txt2)
15:8	R/W	0xa	reg_3dnr_nr3_ymot_only_txtthrd : ; // u8: threshold to luma texture to decide use ymot only
7:0	R/W	0x1e	reg_3dnr_nr3_ymot_only_motthrd : ; // u8: threshold to luma motion to decide use ymot only

Table 9-612 NR3\_CMOT\_PARA 0x2ff4

Bit(s)	R/W	Default	Description
19	R/W	0x1	reg_3dnr_nr3_cmot_only_en : ; // u1: enable signal for ignor luma motion: (cctxt )
18	R/W	0x0	reg_3dnr_nr3_cmot_only_ytmotmode : ; // u1: 0: ymot=cmot+ymot/4; 1: ymot = MIN(ymot, cmot)
17:16	R/W	0x0	reg_3dnr_nr3_cmot_only_txtmode : ; // u2: 0, min(txt0,txt2); 1, max(txt0,txt2);2, (txt0+txt2)/2; 3: sat(txt0, txt2)



Bit(s)	R/W	Default	Description
15:8	R/W	0x14	reg_3dnr_nr3_cmot_only_txtthrd : ; // u8: threshold to chroma texture to decide use cmot only
7:0	R/W	0xf	reg_3dnr_nr3_cmot_only_motthrd : ; // u8: threshold to chroma motion to decide use cmot only

Table 9-613 NR3\_SUREMOT\_YGAIN 0x2ff5

Bit(s)	R/W	Default	Description
31:24	R/W	0x10	reg_3dnr_nr3_suremot_dec_yrate : ; // u8: (norm 16)lpfMot>(dec_rate*txt +ofst) then force lpfMot*frc_gain+frc_ofset
23:16	R/W	0xc	reg_3dnr_nr3_suremot_dec_yofst : ; // u8: lpfMot>(dec_rate*txt +ofst) then force lpfMot*frc_gain+frc_ofset
15:8	R/W	0x40	reg_3dnr_nr3_suremot_frc_ygain : ; // u8: (norm 8)lpfMot>(dec_rate*txt +ofst) then force lpfMot*frc_gain+frc_ofset
7:0	R/W	0x14	reg_3dnr_nr3_suremot_frc_yofst : ; // u8: lpfMot>(dec_rate*txt +ofst) then force lpfMot*frc_gain+frc_ofset

Table 9-614 NR3\_SUREMOT\_CGAIN 0x2ff6

Bit(s)	R/W	Default	Description
31:24	R/W	0x22	reg_3dnr_nr3_suremot_dec_crate : ; // u8: (norm 16)lpfMot>(dec_rate*txt +ofst) then force lpfMot*frc_gain+frc_ofset
23:16	R/W	0x26	reg_3dnr_nr3_suremot_dec_cofst : ; // u8: lpfMot>(dec_rate*txt +ofst) then force lpfMot*frc_gain+frc_ofset
15:8	R/W	0x40	reg_3dnr_nr3_suremot_frc_cgain : ; // u8: (norm 8)lpfMot>(dec_rate*txt +ofst) then force lpfMot*frc_gain+frc_ofset
7:0	R/W	0x14	reg_3dnr_nr3_suremot_frc_cofst : ; // u8: lpfMot>(dec_rate*txt +ofst) then force lpfMot*frc_gain+frc_ofset

### 9.2.3.9 LBUF Registers

Table 9-615 LBUF\_TOP\_CTRL 0x2fff

Bit(s)	R/W	Default	Description
25:20	R/W	6'd0	gate clk control of line buf . LBUF_TOP_CTRL[25:24] is the clk control of current line linebuffer. LBUF_TOP_CTRL[23:22] is the clk control of previous one line.linebuffer, LBUF_TOP_CTRL[21:20] is the clk control of previous two line linebuffer.
17	R/W	1'b1	lbuf_fmt444_mode; format of data store in linebuf ,high mean store 444 data into linebuf
16	R/W	1'b1	lbuf_line5_mode;Store 5 line or 3 lines in linebuf ,high means 5 lines
12:0	R/W	13'd342	pre_lbuf_size: size of linebuf

### 9.2.3.10 DI\_SCALE Registers

**Table 9-616 DI\_SCO\_FIFO\_CTRL 0x374e**

Bit(s)	R/W	Default	Description
28:0	R/W	0x0	sco_fifo_ctrl

**Table 9-617 DI\_SC\_TOP\_CTRL 0x374f**

Bit(s)	R/W	Default	Description
31	R.O	0	prog_interlace : no use // unsigned , default = 0x0
30	R/W	0	path_sel : 1 : di pre scaler for nr inp 0: di post scaler // unsigned , default = 0x0
29	R/W	0	go_field_sel : 1 : di pre go field 0: di post go filed // unsigned , default = 0x0
28	R/W	0	sw_resets : // unsigned , default = 0x0
27	R/W	0	pps_dummy_data_mode : 1: use low 8 bits 0: use high 8 bits // unsigned , default = 0x0
26	R/W	0	field_inv : field reverse// unsigned , default = 0x0
25	R/W	0	reg_field : no use// unsigned , default = 0x0
5:4	R/W	0	hdr_gclk_ctrl : 01 : no cbus clock for hdr other: free cbus clock for hdr
1	R/W	0	reg_gclk_ctrl : 1 : free clock for di scaler register 0: auto gate for di scalercbus // unsigned , default = 0x0

**Table 9-618 DI\_SC\_DUMMY\_DATA 0x3750**

Bit(s)	R/W	Default	Description
29:20	R/W	0	VD1_SC_Y : // unsigned , default = 0x10,dummy data used in the VD1 scaler, according VPP_DOLBY_CTRL[17] 1:set 8bit value 2:set 10bit value
19:10	R/W	0	VD1_SC_CB : // unsigned , default = 0x80,dummy data used in the VD1 scaler, according VPP_DOLBY_CTRL[17] 1:set 8bit value 2:set 10bit value
9 :0	R/W	0	VD1_SC_CR : // unsigned , default = 0x80,dummy data used in the VD1 scaler, according VPP_DOLBY_CTRL[17] 1:set 8bit value 2:set 10bit value

**Table 9-619 DI\_SC\_LINE\_IN\_LENGTH 0x3751**

Bit(s)	R/W	Default	Description
13:0	R/W	14	line_in_length : // unsigned , default = 14'd1920,VD1 scaler input hsize

**Table 9-620 DI\_SC\_PIC\_IN\_HEIGHT 0x3752**

Bit(s)	R/W	Default	Description
12:0	R/W	0x1fff	line_in_height : // unsigned , default = 13'h1fff,VD1 scaler input vsize

**Table 9-621 DI\_SC\_COEF\_IDX 0x3753**

Bit(s)	R/W	Default	Description
15	R/W	0	index_inc : // unsigned , default = 0x0 ,index increment, if bit9 = 1 then (0: index increase 1, 1: index increase 2) else (index increase 2)
14	R/W	0	rd_cbus_coef_en : // unsigned , default = 0x0 ,1: read coef through cbus enable, just for debug purpose in case when we wanna check the coef in ram in correct or not
13	R/W	0	vf_sep_coef_en : // unsigned , default = 0x0 ,if true, vertical separated coef enable
9	R/W	0	high_reso_en : // unsigned , default = 0x0 ,if true, use 9bit resolution coef, other use 8bit resolution coef
8:7	R/W	0	type_index : // unsigned , default = 0x0 ,type of index, 00: vertical coef, 01: vertical chroma coef: 10: horizontal coef, 11: reserved
6:0	R/W	0	coef_index : // unsigned , default = 0x0 ,coef index

**Table 9-622 DI\_SC\_COEF 0x3754**

Bit(s)	R/W	Default	Description
31:24	R/W	0	coef0 : //signed , default = 0x0 , coefficients for vertical filter and horizontal filter
23:16	R/W	0	coef1 : //signed , default = 0x0 , coefficients for vertical filter and horizontal filter
15:8	R/W	0	coef2 : //signed , default = 0x0 , coefficients for vertical filter and horizontal filter
7 :0	R/W	0	coef3 : //signed , default = 0x0 , coefficients for vertical filter and horizontal filter

**Table 9-623 DI\_VSC\_REGION12\_STARTP 0x3755**

Bit(s)	R/W	Default	Description
28:16	R/W	0	region1_startp : //unsigned , default = 0 ,region1 startp
12:0	R/W	0	region2_startp : //unsigned , default = 0 ,region2 startp

**Table 9-624 DI\_VSC\_REGION34\_STARTP 0x3756**

Bit(s)	R/W	Default	Description
28:16	R/W	0	region3_startp : //unsigned , default = 0x0438,region3 startp
12:0	R/W	0	region4_startp : //unsigned , default = 0x0438,region4 startp

**Table 9-625 DI\_VSC\_REGION4\_ENDP 0x3757**

Bit(s)	R/W	Default	Description
12:0	R/W	13	region4_endp : //unsigned , default = 13'd1079 ,region4 endp

**Table 9-626 DI\_VSC\_START\_PHASE\_STEP 0x3758**

Bit(s)	R/W	Default	Description
27:24	R/W	1	integer_part : //unsigned , default = 1,vertical start phase step, (source/dest)* (2^24),integer part of step
23:0	R/W	0	fraction_part : //unsigned , default = 0,vertical start phase step, (source/dest)* (2^24),fraction part of step

**Table 9-627 DI\_VSC\_REGION0\_PHASE\_SLOPE 0x3759**

Bit(s)	R/W	Default	Description
24:0	R/W	0	region0_phase_slope : //signed , default = 0,vertical scaler region0 phase slope, region0 phase slope

**Table 9-628 DI\_VSC\_REGION1\_PHASE\_SLOPE 0x375a**

Bit(s)	R/W	Default	Description
24:0	R/W	0	region1_phase_slope : //signed , default = 0,region1 phase slope

**Table 9-629 DI\_VSC\_REGION3\_PHASE\_SLOPE 0x375b**

Bit(s)	R/W	Default	Description
24:0	R/W	0	region3_phase_slope : //signed , default = 0,region3 phase slope

**Table 9-630 DI\_VSC\_REGION4\_PHASE\_SLOPE 0x375c**

Bit(s)	R/W	Default	Description
24:0	R/W	0	region4_phase_slope : //signed , default = 0,region4 phase slope

**Table 9-631 DI\_VSC\_PHASE\_CTRL 0x375d**

Bit(s)	R/W	Default	Description
18:17	R/W	0	vsc_double_line_mode : //unsigned , default = 0, double line mode, input/output line width of vscler becomes 2X, so only 2 line buffer in this case, use for 3D line by line interleave scaling bit1 true, double the input width and half input height, bit0 true, change line buffer 2 lines instead of 4 lines
16	R.O	0	prog_interlace : //unsigned , default = 0,0: progressive output, 1: interlace output
15	R/W	0	vsc_bot_l0_out_en : //unsigned , default = 0,vertical scaler output line0 in advance or not for bottom field
14:13	R/W	1	vsc_bot_rpt_l0_num : //unsigned , default = 1,vertical scaler initial repeat line0 number for bottom field
11:8	R/W	4	vsc_bot_ini_rcv_num : //unsigned , default = 4,vertical scaler initial receiving number for bottom field
7	R/W	0	vsc_top_l0_out_en : //unsigned , default = 0,vertical scaler output line0 in advance or not for top field

Bit(s)	R/W	Default	Description
6:5	R/W	1	vsc_top_rpt_l0_num : //unsigned , default = 1,vertical scaler initial repeat line0 number for top field
3:0	R/W	4	vsc_top_ini_rcv_num : //unsigned , default = 4,vertical scaler initial receiving number for top field

**Table 9-632 DI\_VSC\_INI\_PHASE 0x375e**

Bit(s)	R/W	Default	Description
31:16	R/W	0	vertical scaler field initial phase for bottom field
15:0	R/W	0	vertical scaler field initial phase for top field

**Table 9-633 DI\_HSC\_REGION12\_STARTP 0x3760**

Bit(s)	R/W	Default	Description
28:16	R/W	0	region1_startp : //unsigned , default = 0,region1 startp
12:0	R/W	0	region2_startp : //unsigned , default = 0,region2 startp

**Table 9-634 DI\_HSC\_REGION34\_STARTP 0x3761**

Bit(s)	R/W	Default	Description
28:16	R/W	0	region3 : startp //unsigned , default = 0x780,region3 startp
12:0	R/W	0	region4 : startp //unsigned , default = 0x780,region4 startp

**Table 9-635 DI\_HSC\_REGION4\_ENDP 0x3762**

Bit(s)	R/W	Default	Description
12:0	R/W	13	region4 : startp //unsigned , default = 13'd1919,region4 startp

**Table 9-636 DI\_HSC\_START\_PHASE\_STEP 0x3763**

Bit(s)	R/W	Default	Description
27:24	R/W	1	integer_part : //unsigned , default = 1,integer part of step
23:0	R/W	0	fraction_part : //unsigned , default = 0,fraction part of step

**Table 9-637 DI\_HSC\_REGION0\_PHASE\_SLOPE 0x3764**

Bit(s)	R/W	Default	Description
24:0	R/W	0	region0_phase_slope : //signed , default = 0,region0 phase slope

**Table 9-638 DI\_HSC\_REGION1\_PHASE\_SLOPE 0x3765**

Bit(s)	R/W	Default	Description
24:0	R/W	0	region0_phase_slope : //signed , default = 0,region1 phase slope

**Table 9-639 DI\_HSC\_REGION3\_PHASE\_SLOPE 0x3766**

Bit(s)	R/W	Default	Description
1900-01-01	R/W	0	region0_phase_slope : //signed , default = 0,region3 phase slope

**Table 9-640 DI\_HSC\_REGION4\_PHASE\_SLOPE 0x3767**

Bit(s)	R/W	Default	Description
24:0	R/W	0	region0_phase_slope : //signed , default = 0,region4 phase slope

**Table 9-641 DI\_HSC\_PHASE\_CTRL 0x3768**

Bit(s)	R/W	Default	Description
22:21	R/W	1	hsc_rpt_p0_num0 : //unsigned , default = 1 ,horizontal scaler initial repeat pixel0 number0
19:16	R/W	4	hsc_ini_rcv_num0 : //unsigned , default = 4 ,horizontal scaler initial receiving number0
15:0	R/W	0	hsc_ini_phase0 : //unsigned , default = 0 ,horizontal scaler top field initial phase0

**Table 9-642 DI\_SC\_MISC 0x3769**

Bit(s)	R/W	Default	Description
22	R/W	0	hsc_len_div2_en : //unsigned , default = 0 ,if true, divide VSC line length 2 as the HSC input length, othwise VSC length length is the same as the VSC line length just for special usage, more flexibility
21	R/W	0	lbuf_mode : //unsigned , default = 0 ,if true, prevsc uses lin buffer, otherwise prevsc does not use line buffer, it should be same as prevsc_en
20	R/W	0	prehsc_en : //unsigned , default = 0 ,prehsc_en
19	R/W	0	prevsc_en : //unsigned , default = 0 ,prevsc_en
18	R/W	0	vsc_en : //unsigned , default = 0 ,vsc_en
17	R/W	0	hsc_en : //unsigned , default = 0 ,hsc_en
16	R/W	0	sc_top_en : //unsigned , default = 0 ,scale_top_en
15	R/W	0	sc_vd_en : //unsigned , default = 0 ,video1 scale out enable
12	R/W	1	hsc_nonlinear_4region_en : //unsigned , default = 1 ,if true, region0,region4 are nonlinear regions, otherwise they are not scaling regions, for horizontal scaler
10:8	R/W	0	hsc_bank_length : //unsigned , default = 0 ,horizontal scaler bank length
5	R/W	4	vsc_phase_field_mode : //unsigned , default = 4 ,vertical scaler phase field mode, if true, disable the opposite parity line output, more bandwidth needed if output 1080i

Bit(s)	R/W	Default	Description
4	R/W	0	vsc_nonlinear_4region_en : //unsigned , default = 0 ,if true, region0,region4 are nonlinear regions, otherwise they are not scaling regions, for vertical scaler
2:0	R/W	4	vsc_bank_length : //unsigned , default = 4 ,vertical scaler bank length

Table 9-643 DI\_HSC\_PHASE\_CTRL1 0x376a

Bit(s)	R/W	Default	Description
22:21	R/W	1	hsc_rpt_p0_num0 : //unsigned , default = 1 ,horizontal scaler initial repeat pixel0 number0
19:16	R/W	4	hsc_ini_rcv_num0 : //unsigned , default = 4 ,horizontal scaler initial receiving number0
15:0	R/W	0	hsc_ini_phase0 : //unsigned , default = 0 ,horizontal scaler top field initial phase0

Table 9-644 VPP\_SC\_MISC 0x1D19

Bit(s)	R/W	Default	Description
22	R/W	0	hsc_len_div2_en : //unsigned , default = 0 ,if true, divide VSC line length 2 as the HSC input length, othwise VSC length length is the same as the VSC line length just for special usage, more flexibility
21	R/W	0	lbuf_mode : //unsigned , default = 0 ,if true, prevsc uses lin buffer, otherwise prevsc does not use line buffer, it should be same as prevsc_en
20	R/W	0	prehsc_en : //unsigned , default = 0 ,prehsc_en
19	R/W	0	prevsc_en : //unsigned , default = 0 ,prevsc_en
18	R/W	0	vsc_en : //unsigned , default = 0 ,vsc_en
17	R/W	0	hsc_en : //unsigned , default = 0 ,hsc_en
16	R/W	0	sc_top_en : //unsigned , default = 0 ,scale_top_en
15	R/W	0	sc_vd_en : //unsigned , default = 0 ,video1 scale out enable
12	R/W	1	hsc_nonlinear_4region_en : //unsigned , default = 1 ,if true, region0,region4 are nonlinear regions, otherwise they are not scaling regions, for horizontal scaler
10:8	R/W	0	hsc_bank_length : //unsigned , default = 0 ,horizontal scaler bank length
5	R/W	4	vsc_phase_field_mode : //unsigned , default = 4 ,vertical scaler phase field mode, if true, disable the opposite parity line output, more bandwidth needed if output 1080i
4	R/W	0	vsc_nonlinear_4region_en : //unsigned , default = 0 ,if true, region0,region4 are nonlinear regions, otherwise they are not scaling regions, for vertical scaler
2:0	R/W	4	vsc_bank_length : //unsigned , default = 4 ,vertical scaler bank length

Table 9-645 DI\_HSC\_INI\_PAT\_CTRL 0x376b

Bit(s)	R/W	Default	Description
31:24	R/W	0	prehsc_pattern : //unsigned , default = 0 ,prehsc pattern, each patten 1 bit, from lsb -> msb
22:20	R/W	0	prehsc_pat_star : //unsigned , default = 0 ,prehsc pattern start

Bit(s)	R/W	Default	Description
18:16	R/W	0	prehsc_pat_end : //unsigned , default = 0, prehsc pattern end
15:8	R/W	0	hsc_pattern : //unsigned , default = 0, hsc pattern, each patten 1 bit, from lsb -> msb
6:4	R/W	0	hsc_pat_start : //unsigned , default = 0, hsc pattern start
2:0	R/W	0	hsc_pat_end : //unsigned , default = 0, hsc pattern end

**Table 9-646 DI\_SC\_GCLK\_CTRL 0x376c**

Bit(s)	R/W	Default	Description
15:0	R/W	0	vpp_sc_gclk_ctrl : //unsigned , default = 0,

**Table 9-647 DI\_SC\_HOLD\_LINE 0x376d**

Bit(s)	R/W	Default	Description
31:0	R/W	0	sc_hold_line : //unsigned , default = 0,

**Table 9-648 DI\_HDR\_IN\_HSIZE 0x376e**

Bit(s)	R/W	Default	Description
12:0	R/W	0	hdr input h size

**Table 9-649 DI\_HDR\_IN\_VSIZE 0x376f**

Bit(s)	R/W	Default	Description
12:0	R/W	0	hdr input v size

**Table 9-650 DI\_HDR2\_CTRL 0x3770**

Bit(s)	R/W	Default	Description
20:18	R/W	0	reg_din_swap : // unsigned , default = 0
17	R/W	0	reg_out_fmt : // unsigned , default = 0
16	R/W	0	reg_only_mat : // unsigned , default = 0
13	R/W	0	reg_VDIN0_HDR2_top_en : // unsigned , default = 0
12	R/W	1	reg_cgain_mode : // unsigned , default = 1
7: 6	R/W	1	reg_gmut_mode : // unsigned , default = 1
5	R/W	0	reg_in_shift : // unsigned , default = 0
4	R/W	1	reg_in_fmt : // unsigned , default = 1
3	R/W	1	reg_eo_enable : // unsigned , default = 1
2	R/W	1	reg_oe_enable : // unsigned , default = 1



Bit(s)	R/W	Default	Description
1	R/W	1	reg_ogain_enable : // unsigned , default = 1
0	R/W	1	reg_cgain_enable : // unsigned , default = 1

Table 9-651 DI\_HDR2\_CLK\_GATE 0x3771

Bit(s)	R/W	Default	Description
31:30	R/W	0	clk_tm : gate clock ctrl (main clock) // unsigned , default = 0
29:28	R/W	0	output : matrix clock gate ctrl // unsigned , default = 0
25:24	R/W	0	input : matrix clock gate ctrl // unsigned , default = 0
23:22	R/W	0	hdr : top cbus clock gate ctrl // unsigned , default = 0
21:20	R/W	0	eotf : cbus clock gate ctrl // unsigned , default = 0
19:18	R/W	0	oetf : cbus clock gate ctrl // unsigned , default = 0
17:16	R/W	0	gamma : mult cbus clock gate ctrl // unsigned , default = 0
15:14	R/W	0	adaptive : cbus scaler clock gate ctrl // unsigned , default = 0
13:12	R/W	0	cgain : cbus clock gate ctrl // unsigned , default = 0
11:10	R/W	0	eotf : clock gate ctrl // unsigned , default = 0
9:8	R/W	0	oetf : clock gate ctrl // unsigned , default = 0
7:6	R/W	0	gamma : mult clock gate ctrl // unsigned , default = 0
5:4	R/W	0	adaptive : scaler clock gate ctrl // unsigned , default = 0
3:2	R/W	0	uv : gain clock gate ctrl // unsigned , default = 0
1:0	R/W	0	cgain : clock gate ctrl // unsigned , default = 0

Table 9-652 DI\_HDR2\_MATRIXI\_COEF00\_01 0x3772

Bit(s)	R/W	Default	Description
28:16	R/W	0	coef00 : // signed , default = 0
12:0	R/W	0	coef01 : // signed , default = 0

Table 9-653 DI\_HDR2\_MATRIXI\_COEF02\_10 0x3773

Bit(s)	R/W	Default	Description
28:16	R/W	0	coef02 : // signed , default = 0
12:0	R/W	0	coef10 : // signed , default = 0

Table 9-654 DI\_HDR2\_MATRIXI\_COEF11\_12 0x3774

Bit(s)	R/W	Default	Description
28:16	R/W	0	coef11 : // signed , default = 0
12:0	R/W	0	coef12 : // signed , default = 0

**Table 9-655 DI\_HDR2\_MATRIXI\_COEF20\_21 0x3775**

Bit(s)	R/W	Default	Description
28:16	R/W	0	coef20 : // signed , default = 0
12:0	R/W	0	coef21 : // signed , default = 0

**Table 9-656 DI\_HDR2\_MATRIXI\_COEF22 0x3776**

Bit(s)	R/W	Default	Description
12:0	R/W	0	coef22 : // signed , default = 0

**Table 9-657 DI\_HDR2\_MATRIXI\_COEF30\_31 0x3777**

Bit(s)	R/W	Default	Description
28:16	R/W	0	coef13 : // signed , default = 0
12:0	R/W	0	coef14 : // signed , default = 0

**Table 9-658 DI\_HDR2\_MATRIXI\_COEF32\_40 0x3778**

Bit(s)	R/W	Default	Description
28:16	R/W	0	coef23 : // signed , default = 0
12:0	R/W	0	coef24 : // signed , default = 0

**Table 9-659 DI\_HDR2\_MATRIXI\_COEF41\_42 0x3779**

Bit(s)	R/W	Default	Description
28:16	R/W	0	coef15 : // signed , default = 0
12:0	R/W	0	coef25 : // signed , default = 0

**Table 9-660 DI\_HDR2\_MATRIXI\_OFFSET0\_1 0x377A**

Bit(s)	R/W	Default	Description
26:16	R/W	0	offset0 : // signed , default = 0
10:0	R/W	0	offset1 : // signed , default = 0

**Table 9-661 DI\_HDR2\_MATRIXI\_OFFSET2 0x377B**

Bit(s)	R/W	Default	Description
10:0	R/W	0	offset2 : // signed , default = 0

**Table 9-662 DI\_HDR2\_MATRIXI\_PRE\_OFFSET0\_1 0x377C**

Bit(s)	R/W	Default	Description
26:16	R/W	0	pre_offset0 : // signed , default = 0
10:0	R/W	0	pre_offset1 : // signed , default = 0

**Table 9-663 DI\_HDR2\_MATRIXI\_PRE\_OFFSET2 0x377D**

Bit(s)	R/W	Default	Description
10:0	R/W	0	pre_offset2 : // signed , default = 0

**Table 9-664 DI\_HDR2\_MATRIXO\_COEF00\_01 0x377E**

Bit(s)	R/W	Default	Description
28:16	R/W	0	coef00 : // signed , default = 0
12:0	R/W	0	coef01 : // signed , default = 0

**Table 9-665 DI\_HDR2\_MATRIXO\_COEF02\_10 0x377F**

Bit(s)	R/W	Default	Description
28:16	R/W	0	coef02 : // signed , default = 0
12:0	R/W	0	coef10 : // signed , default = 0

**Table 9-666 DI\_HDR2\_MATRIXO\_COEF11\_12 0x3780**

Bit(s)	R/W	Default	Description
28:16	R/W	0	coef11 : // signed , default = 0
12:0	R/W	0	coef12 : // signed , default = 0

**Table 9-667 DI\_HDR2\_MATRIXO\_COEF20\_21 0x3781**

Bit(s)	R/W	Default	Description
28:16	R/W	0	coef20 : // signed , default = 0
12:0	R/W	0	coef21 : // signed , default = 0

**Table 9-668 DI\_HDR2\_MATRIXO\_COEF22 0x3782**

Bit(s)	R/W	Default	Description
12:0	R/W	0	coef22 : // signed , default = 0

**Table 9-669 DI\_HDR2\_MATRIXO\_COEF30\_31 0x3783**

Bit(s)	R/W	Default	Description
28:16	R/W	0	coef13 : // signed , default = 0
12:0	R/W	0	coef14 : // signed , default = 0

**Table 9-670 DI\_HDR2\_MATRIXO\_COEF32\_40 0x3784**

Bit(s)	R/W	Default	Description
28:16	R/W	0	coef23 : // signed , default = 0
12:0	R/W	0	coef24 : // signed , default = 0

**Table 9-671 DI\_HDR2\_MATRIXO\_COEF41\_42 0x3785**

Bit(s)	R/W	Default	Description
28:16	R/W	0	coef15 : // signed , default = 0
12:0	R/W	0	coef25 : // signed , default = 0

**Table 9-672 DI\_HDR2\_MATRIXO\_OFFSET0\_1 0x3786**

Bit(s)	R/W	Default	Description
26:16	R/W	0	offset0 : // signed , default = 0
10:0	R/W	0	offset1 : // signed , default = 0

**Table 9-673 DI\_HDR2\_MATRIXO\_OFFSET2 0x3787**

Bit(s)	R/W	Default	Description
10:0	R/W	0	offset2 : // signed , default = 0

**Table 9-674 DI\_HDR2\_MATRIXO\_PRE\_OFFSET0\_1 0x3788**

Bit(s)	R/W	Default	Description
26:16	R/W	0	pre_offset0 : // signed , default = 0
10:0	R/W	0	pre_offset1 : // signed , default = 0

**Table 9-675 DI\_HDR2\_MATRIXO\_PRE\_OFFSET2 0x3789**

Bit(s)	R/W	Default	Description
10:0	R/W	0	pre_offset2 : // signed , default = 0

**Table 9-676 DI\_HDR2\_MATRIXI\_CLIP 0x378A**

Bit(s)	R/W	Default	Description
19:8	R/W	0	comp_th : // unsigned , default = 0
7:5	R/W	0	conv_rs : // unsigned , default = 0
4:3	R/W	0	clmod : // unsigned , default = 0

**Table 9-677 DI\_HDR2\_MATRIXO\_CLIP 0x378B**

Bit(s)	R/W	Default	Description
19:8	R/W	0	comp_th : // unsigned , default = 0
7:5	R/W	0	conv_rs : // unsigned , default = 0
4:3	R/W	0	clmod : // unsigned , default = 0

**Table 9-678 DI\_HDR2\_CGAIN\_OFFT 0x378C**

Bit(s)	R/W	Default	Description
26:16	R/W	0	reg_cgain_offt2 : // signed , default = 0
10:0	R/W	0	reg_cgain_offt1 : // signed , default = 0

**Table 9-679 DI\_EOTF\_LUT\_ADDR\_PORT 0x378E**

Bit(s)	R/W	Default	Description
7:0	R/W	0	eotf_lut_addr : // unsigned , default = 0

**Table 9-680 DI\_EOTF\_LUT\_DATA\_PORT 0x378F**

Bit(s)	R/W	Default	Description
19:0	R/W	0	eotf_lut_data : // unsigned , default = 0

**Table 9-681 DI\_OETF\_LUT\_ADDR\_PORT 0x3790**

Bit(s)	R/W	Default	Description
7:0	R/W	0	oetf_lut_addr : // unsigned , default = 0

**Table 9-682 DI\_OETF\_LUT\_DATA\_PORT 0x3791**

Bit(s)	R/W	Default	Description
11:0	R/W	0	oetf_lut_data : // unsigned , default = 0

**Table 9-683 DI\_CGAIN\_LUT\_ADDR\_PORT 0x3792**

Bit(s)	R/W	Default	Description
7:0	R/W	0	cgain_lut_addr : // unsigned , default = 0

**Table 9-684 DI\_CGAIN\_LUT\_DATA\_PORT 0x3793**

Bit(s)	R/W	Default	Description
11:0	R/W	0	cgain_lut_data : // unsigned , default = 0

**Table 9-685 DI\_HDR2\_CGAIN\_COEF0 0x3794**

Bit(s)	R/W	Default	Description
27:16	R/W	0	reg_cgain_coef1 : // unsigned , default = 0
11:0	R/W	0	reg_cgain_coef0 : // unsigned , default = 0

**Table 9-686 DI\_HDR2\_CGAIN\_COEF1 0x3795**

Bit(s)	R/W	Default	Description
11:0	R/W	0	reg_cgain_coef2 : // unsigned , default = 0

**Table 9-687 DI\_OGAIN\_LUT\_ADDR\_PORT 0x3796**

Bit(s)	R/W	Default	Description
7:0	R/W	0	ogain_lut_addr : // unsigned , default = 0

**Table 9-688 DI\_OGAIN\_LUT\_DATA\_PORT 0x3797**

Bit(s)	R/W	Default	Description
11:0	R/W	0	ogain_lut_data : // unsigned , default = 0

**Table 9-689 DI\_HDR2\_ADPS\_CTRL 0x3798**

Bit(s)	R/W	Default	Description
6	R/W	1	reg_adpscl_bypass2 : // unsigned , default = 1
5	R/W	1	reg_adpscl_bypass1 : // unsigned , default = 1
4	R/W	1	reg_adpscl_bypass0 : // unsigned , default = 1
1:0	R/W	1	reg_adpscl_mode : // unsigned , default = 1

**Table 9-690 DI\_HDR2\_ADPS\_ALPHA0 0x3799**

Bit(s)	R/W	Default	Description
29:16	R/W	0x1000	reg_adpscl_alpha1 : // unsigned , default = 0x1000
13:0	R/W	0x1000	reg_adpscl_alpha0 : // unsigned , default = 0x1000

**Table 9-691 DI\_HDR2\_ADPS\_ALPHA1 0x379A**

Bit(s)	R/W	Default	Description
27:24	R/W	0xc	reg_adpscl_shift0 : // unsigned , default = 0xc
23:20	R/W	0xc	reg_adpscl_shift1 : // unsigned , default = 0xc
19:16	R/W	0xc	reg_adpscl_shift2 : // unsigned , default = 0xc
13:0	R/W	0x1000	reg_adpscl_alpha2 : // unsigned , default = 0x1000

**Table 9-692 DI\_HDR2\_ADPS\_BETA0 0x379B**

Bit(s)	R/W	Default	Description
20	R/W	0	reg_adpscl_beta0_s : // unsigned , default = 0
19:0	R/W	0xfc000	reg_adpscl_beta0 : // unsigned , default = 0xfc000

**Table 9-693 DI\_HDR2\_ADPS\_BETA1 0x379C**

Bit(s)	R/W	Default	Description
20	R/W	0	reg_adpscl_beta1_s : // unsigned , default = 0
19:0	R/W	0xfc000	reg_adpscl_beta1 : // unsigned , default = 0xfc000

**Table 9-694 DI\_HDR2\_ADPS\_BETA2 0x379D**

Bit(s)	R/W	Default	Description
20	R/W	0	reg_adpscl_beta2_s : // unsigned , default = 0
19:0	R/W	0xfc000	reg_adpscl_beta2 : // unsigned , default = 0xfc000

**Table 9-695 DI\_HDR2\_ADPS\_COEF0 0x379E**

Bit(s)	R/W	Default	Description
27:16	R/W	460	reg_adpscl_ys_coef1 : // unsigned , default = 460
11:0	R/W	1188	reg_adpscl_ys_coef0 : // unsigned , default = 1188

**Table 9-696 DI\_HDR2\_ADPS\_COEF1 0x379F**

Bit(s)	R/W	Default	Description
11:0	R/W	104	reg_adpscl_ys_coef2 : // unsigned , default = 104

**Table 9-697 DI\_HDR2\_GMUT\_CTRL 0x37A0**

Bit(s)	R/W	Default	Description
3:0	R/W	14	reg_gmut_shift : // unsigned , default = 14

**Table 9-698 DI\_HDR2\_GMUT\_COEF0 0x37A1**

Bit(s)	R/W	Default	Description
31:16	R/W	674	reg_gmut_coef01 : // unsigned , default = 674
15:0	R/W	1285	reg_gmut_coef00 : // unsigned , default = 1285

**Table 9-699 DI\_HDR2\_GMUT\_COEF1 0x37A2**

Bit(s)	R/W	Default	Description
31:16	R/W	142	reg_gmut_coef10 : // unsigned , default = 142
15:0	R/W	89	reg_gmut_coef02 : // unsigned , default = 89

**Table 9-700 DI\_HDR2\_GMUT\_COEF2 0x37A3**

Bit(s)	R/W	Default	Description
31:16	R/W	23	reg_gmut_coef12 : // unsigned , default = 23
15:0	R/W	1883	reg_gmut_coef11 : // unsigned , default = 1883

**Table 9-701 DI\_HDR2\_GMUT\_COEF3 0x37A4**

Bit(s)	R/W	Default	Description
31:16	R/W	180	reg_gmut_coef21 : // unsigned , default = 180
15:0	R/W	34	reg_gmut_coef20 : // unsigned , default = 34

**Table 9-702 DI\_HDR2\_GMUT\_COEF4 0x37A5**

Bit(s)	R/W	Default	Description
15:0	R/W	1834	reg_gmut_coef22 : // unsigned , default = 1834

**Table 9-703 DI\_HDR2\_PIPE\_CTRL1 0x37A6**

Bit(s)	R/W	Default	Description
31:24	R/W	4	vblank_num_oetf : // unsigned , default = 4
23:16	R/W	4	hblank_num_oetf : // unsigned , default = 4
15:8	R/W	10	vblank_num_eotf : // unsigned , default = 10
7:0	R/W	10	hblank_num_eotf : // unsigned , default = 10



**Table 9-704 DI\_HDR2\_PIPE\_CTRL2 0x37A7**

Bit(s)	R/W	Default	Description
31:24	R/W	10	vblank_num_cgain : // unsigned , default = 10
23:16	R/W	10	hblank_num_cgain : // unsigned , default = 10
15:8	R/W	11	vblank_num_gmut : // unsigned , default = 11
7:0	R/W	11	hblank_num_gmut : // unsigned , default = 11

**Table 9-705 DI\_HDR2\_PIPE\_CTRL3 0x37A8**

Bit(s)	R/W	Default	Description
31:24	R/W	22	vblank_num_adps : // unsigned , default = 22
23:16	R/W	2	hblank_num_adps : // unsigned , default = 2
15:8	R/W	4	vblank_num_uv : // unsigned , default = 4
7:0	R/W	4	hblank_num_uv : // unsigned , default = 4

**Table 9-706 DI\_HDR2\_PROC\_WIN1 0x37A9**

Bit(s)	R/W	Default	Description
28:16	R/W	0	proc_win_h_ed : // unsigned , default = 0
12:0	R/W	0	proc_win_h_st : // unsigned , default = 0

**Table 9-707 DI\_HDR2\_PROC\_WIN2 0x37AA**

Bit(s)	R/W	Default	Description
31	R/W	0	proc_win_gmut_en : // unsigned , default = 0
30	R/W	0	proc_win_adps_en : // unsigned , default = 0
29	R/W	0	proc_win_cgain_en : // unsigned , default = 0
28:16	R/W	0	proc_win_v_ed : // unsigned , default = 0
12:0	R/W	0	proc_win_v_st : // unsigned , default = 0

**Table 9-708 DI\_HDR2\_MATRIXI\_EN\_CTRL 0x37AB**

Bit(s)	R/W	Default	Description
5:4	R/W	0	matrix_gclk_ctrl : // unsigned , default = 0
1	R/W	0	enable_sync_sel : // unsigned , default = 0
0	R/W	0	matrix_conv_en : // unsigned , default = 0

**Table 9-709 DI\_HDR2\_MATRIXO\_EN\_CTRL 0x37AC**

Bit(s)	R/W	Default	Description
5:4	R/W	0	matrix_gclk_ctrl : // unsigned , default = 0
1	R/W	0	enable_sync_sel : // unsigned , default = 0
0	R/W	0	matrix_conv_en : // unsigned , default = 0

### 9.2.3.11 NR\_SCALE Registers

**Table 9-710 NRDSWR\_X 0x37f9**

Bit(s)	R/W	Default	Description
31:30	R/W	2	burst_len : unsigned , default = 2
29	R/W	0	rev_x : unsigned , default = 0
28:16	R/W	0	start_x : unsigned , default = 0
12:0	R/W	2	end_x : unsigned , default = 2cf

**Table 9-711 NRDSWR\_Y 0x37fa**

Bit(s)	R/W	Default	Description
31:30	R/W	0	canvas_id : unsigned , default = 0
29	R/W	0	rev_y : unsigned , default = 0
28:16	R/W	0	start_y : unsigned , default = 0
12:0	R/W	0	end_y : unsigned , default = 0x1df

**Table 9-712 NRDSWR\_CTRL 0x37fb**

Bit(s)	R/W	Default	Description
31:16	R/W	0	urgent_ctrl : unsigned , default = 0
15	R/W	0	force_wvalid : unsigned , default = 0
14	R/W	0	canvas_syncen : unsigned , default = 0
13	R/W	1	canvas_wr : unsigned , default = 1
12	R/W	0	req_en : unsigned , default = 0
10	R/W	0	clr_wrrsp : unsigned , default = 0
8	R/W	0	urgent : unsigned , default = 0
7:0	R/W	0	canvas_index : unsigned , default = 0

**Table 9-713 NRDSWR\_CAN\_SIZE 0x37fc**

Bit(s)	R/W	Default	Description
30:29	R/W	0	reg_rst : unsigned , default = 0
28:16	R/W	0	hsizem1 : unsigned , default = 0x2cf
14	R/W	0	reg_reset : unsigned , default = 0
13	R/W	0	little_endian : unsigned , default = 0
12:0	R/W	0	vsizem1 : unsigned , default = 0x1df

**Table 9-714 NR\_DS\_BUF\_SIZE 0x3740**

Bit(s)	R/W	Default	Description
31:24	R.O	96	dsbuf_rowmax : // unsigned , default = 96
23:16	R/W	128	dsbuf_colmax : // unsigned , default = 128
15: 8	R.O	128	dsbuf_ow : // unsigned , default = 128
7: 0	R/W	128	dsbuf_ocol : // unsigned , default = 128

**Table 9-715 NR\_DS\_CTRL 0x3741**

Bit(s)	R/W	Default	Description
30	R/W	0	Nr_ds_enable
29:24	R/W	8	reg_h_step : // unsigned , default = 8 rand lut0
21:16	R/W	8	reg_v_step : // unsigned , default = 8 rand lut0
14:12	R/W	4	reg_haa_sel : // unsigned , default = 4
10: 8	R/W	4	reg_vaa_sel : // unsigned , default = 4
6: 4	R/W	1	reg_use_hphase : // unsigned , default = 1
0	R/W	0	reg_yuv_bldmode : // unsigned , default = 0

**Table 9-716 NR\_DS\_OFFSET 0x3742**

Bit(s)	R/W	Default	Description
25:16	R/W	0	reg_h_ofst : // signed , default = 0
9: 0	R/W	0	reg_v_ofst : // signed , default = 0

**Table 9-717 NR\_DS\_BLD\_COEF 0x3743**

Bit(s)	R/W	Default	Description
23:16	R/W	128	reg_yuv_bldcoef2 : // unsigned , default = 128
15: 8	R/W	64	reg_yuv_bldcoef1 : // unsigned , default = 64
7: 0	R/W	64	reg_yuv_bldcoef0 : // unsigned , default = 64

### 9.2.3.12 MCDI Registers

**Table 9-718 MCDI\_HV\_SIZEIN 0x2f00**

Bit(s)	R/W	Default	Description
31-29	R/W		reserved
28-16	R/W	1024	reg_mcdi_hsize image horizontal size (number of cols) default=1024
15-13	R/W		reserved
12-0	R/W	1024	reg_mcdi_vsize image vertical size (number of rows) default=1024

**Table 9-719 MCDI\_HV\_BLKSIZEIN 0x2f01**

Bit(s)	R/W	Default	Description
31	R/W	0	reg_mcdi_vrev default = 0
30	R/W	0	reg_mcdi_hrev default = 0
29-28	R/W		reserved
27-16	R/W	1024	reg_mcdi_blkhsz image horizontal blk size (number of cols) default=1024
15-13	R/W		reserved
11-0	R/W	1024	reg_mcdi_blkvsize image vertical blk size (number of rows) default=1024

**Table 9-720 MCDI\_BLKTOTAL 0x2f02**

Bit(s)	R/W	Default	Description
31-24	R/W		reserved
23-0	R/W	0	reg_mcdi_blktotal

**Table 9-721 MCDI\_MOTINEN 0x2f03**

Bit(s)	R/W	Default	Description
31-2	R/W		reserved
1	R/W	1	reg_mcdi_motionrefen. enable motion refinement of MA, default = 1
0	R/W	1	reg_mcdi_motionparadoxen. enable motion paradox detection, default = 1

**Table 9-722 MCDI\_CTRL\_MODE 0x2f04**

Bit(s)	R/W	Default	Description
31-29	R/W		reserved
28	R/W	0	mc info read enable
27-26	R/W	2	reg_mcdi_lmlocken 0:disable, 1: use max Lmv, 2: use no-zero Lmv, lmv lock enable mode, default = 2
25	R/W	1	reg_mcdi_reldetpchk 0-unable; 1: enable enable repeat pattern check (not repeat mv detection) in rel det part, default = 1

Bit(s)	R/W	Default	Description
24	R/W	1	reg_mcdi_reldetgmvpd22chken 0-unable; 1: enable enable pull-down 22 mode check in gmV lock mode for rel det, default = 1
23	R/W	1	reg_mcdi_pd22chken 0-unable; 1: enable enable pull-down 22 mode check (lock) function, default = 1
22	R/W	1	reg_mcdi_reldetlpfen 0-unable; 1: enable enable det value lpf, default = 1
21	R/W	1	reg_mcdi_reldetlmvpd22chken 0-unable; 1: enable enable pull-down 22 mode check in lmv lock mode for rel det, default = 1
20	R/W	1	reg_mcdi_reldetlmvdifchken 0-unable; 1: enable enable lmv dif check in lmv lock mode for rel det, default = 1
19	R/W	1	reg_mcdi_reldetgmvdifchken 0-unable; 1: enable enable lmv dif check in lmv lock mode for rel det, default = 1
18	R/W	1	reg_mcdi_reldetpd22chken 0-unable; 1: enable enable pull-down 22 mode check for rel det refinement, default = 1
17	R/W	1	reg_mcdi_reldetfrqchken 0-unable; 1: enable enable mv frequency check in rel det, default = 1
16	R/W		reg_mcdi_qmeen 0-unable; 1: enable enable quarter motion estimation, default = 1
15	R/W	1	reg_mcdi_refrptmven 0-unable; 1: enable use repeat mv in refinement, default = 1
14	R/W	1	reg_mcdi_refgmven 0-unable; 1: enable use gmV in refinement, default = 1
13	R/W	1	reg_mcdi_reflmven 0-unable; 1: enable use lmvS in refinement, default = 1
12	R/W	1	reg_mcdi_refnmven 0-unable; 1: enable use neighoring mvS in refinement, default = 1
11	R/W		reserved
10	R/W	1	reg_mcdi_referrfrqchken 0-unable; 1: enable enable mv frequency check while finding min err in ref, default = 1
9	R/W	1	reg_mcdi_refen 0-unable; 1: enable enable mv refinement, default = 1
8	R/W	1	reg_mcdi_horlineen 0-unable; 1: enable enable horizontal lines detection by sad map, default = 1
7	R/W	1	reg_mcdi_highvertfrqdeten 0-unable; 1: enable enable high vertical frequency pattern detection, default = 1
6	R/W	1	reg_mcdi_gmvlocken 0-unable; 1: enable enable gmV lock mode, default = 1
5	R/W	1	reg_mcdi_rptmven 0-unable; 1: enable enable repeat pattern detection, default = 1
4	R/W	1	reg_mcdi_gmven 0-unable; 1: enable enable global motion estimation, default = 1
3	R/W	1	reg_mcdi_lmven 0-unable; 1: enable enable line mv estimation for hme, default = 1
2	R/W	1	reg_mcdi_chkedgeen 0-unable; 1: enable enable check edge function, default = 1
1	R/W	1	reg_mcdi_txtdeten 0-unable; 1: enable enable texture detection, default = 1

**Table 9-723 MCDI\_UNI\_MVDST 0x2f05**

Bit(s)	R/W	Default	Description
31-20	R/W		reserved
19-17	R/W	1	reg_mcdi_unimvdstabsseg0 segment0 for uni-mv abs, default = 1
16-12	R/W	15	reg_mcdi_unimvdstabsseg1 segment1 for uni-mv abs, default = 15
11-8	R/W	2	reg_mcdi_unimvdstabsdifgain0 2/2, gain0 of uni-mv abs dif for segment0, normalized 2 to '1', default = 2
7-5	R/W	2	reg_mcdi_unimvdstabsdifgain1 2/2, gain1 of uni-mv abs dif for segment1, normalized 2 to '1', default = 2
4-2	R/W	2	reg_mcdi_unimvdstabsdifgain2 2/2, gain2 of uni-mv abs dif beyond segment1, normalized 2 to '1', default = 2
1-0	R/W	0	reg_mcdi_unimvdstsgnshft shift for neighboring distance of uni-mv, default = 0

**Table 9-724 MCDI\_BI\_MVDST 0x2f06**

Bit(s)	R/W	Default	Description
31-20	R/W		reserved
19-17	R/W	1	reg_mcdi_bimvdstabsseg0 segment0 for bi-mv abs, default = 1
16-12	R/W	9	reg_mcdi_bimvdstabsseg1 segment1 for bi-mv abs, default = 9
11-8	R/W	6	reg_mcdi_bimvdstabsdifgain0 6/2, gain0 of bi-mv abs dif for segment0, normalized 2 to '1', default = 6
7-5	R/W	3	reg_mcdi_bimvdstabsdifgain1 3/2, gain1 of bi-mvabs dif for segment1, normalized 2 to '1', default = 3
4-2	R/W	2	reg_mcdi_bimvdstabsdifgain2 2/2, gain2 of bi-mvabs dif beyond segment1, normalized 2 to '1', default = 2
1-0	R/W	0	reg_mcdi_bimvdstsgnshft shift for neighboring distance of bi-mv, default = 0

**Table 9-725 MCDI\_SAD\_GAIN 0x2f07**

Bit(s)	R/W	Default	Description
31-19	R/W		reserved
18-17	R/W	3	reg_mcdi_unisadcorepxlgain uni-sad core pixels gain, default = 3
16	R/W	0	reg_mcdi_unisadcorepxlnormen enable uni-sad core pixels normalization, default = 0
15-11	R/W		reserved
10-9	R/W	3	reg_mcdi_bisadcorepxlgain bi-sad core pixels gain, default = 3
8	R/W	1	reg_mcdi_bisadcorepxlnormen enable bi-sad core pixels normalization, default = 1
7-3	R/W		reserved
2-1	R/W	3	reg_mcdi_biqsadcorepxlgain bi-qsad core pixels gain, default = 3
0	R/W	1	reg_mcdi_biqsadcorepxlnormen enable bi-qsad core pixels normalization, default = 1

**Table 9-726 MCDI\_TXT\_THD 0x2f08**

Bit(s)	R/W	Default	Description
31-24	R/W		reserved
23-16	R/W	24	reg_mcdi_txtminmaxdifthd, min max dif threshold ( $\geq$ ) for texture detection, default = 24
15-8	R/W	9	reg_mcdi_txtmeandifthd, mean dif threshold ( $<$ ) for texture detection, default = 9
7-3	R/W		reserved
2-0	R/W	2	reg_mcdi_txtdetthd, texture detecting threshold, 0~4, default = 2

**Table 9-727 MCDI\_FLT\_MODESEL 0x2f09**

Bit(s)	R/W	Default	Description
31	R/W		reserved
30-28	R/W	1	reg_mcdi_fltorlineselmode mode for horizontal line detecting flat calculation, default = 1, same as below
27	R/W		reserved
26-24	R/W	4	reg_mcdi_fltgmvselmode mode for gmv flat calculation, default = 4, same as below
23	R/W		reserved
22-20	R/W	2	reg_mcdi_fltadselmode mode for sad flat calculation, default = 2, same as below
19	R/W		reserved
18-16	R/W	3	reg_mcdi_fltbadwselmode mode for badw flat calculation, default = 3, same as below
15	R/W		reserved
14-12	R/W	4	reg_mcdi_fltptmvselmode mode for repeat mv flat calculation, default = 4, same as below
11	R/W		reserved
10-8	R/W	4	reg_mcdi_fltbadrelselmode mode for bad rel flat calculation, default = 4, same as below
7	R/W		reserved
6-4	R/W	2	reg_mcdi_fltcolcfdselmode mode for col cfd flat calculation, default = 2, same as below
3	R/W		reserved
2-0	R/W	2	reg_mcdi_fltpd22chksselmode mode for pd22 check flat calculation, default = 2, 0:cur dif h, 1: cur dif v, 2: pre dif h, 3: pre dif v, 4: cur flt, 5: pre flt, 6: cur+pre, 7: max all(cur,pre)

**Table 9-728 MCDI\_CHK\_EDGE\_THD 0x2f0a**

Bit(s)	R/W	Default	Description
23-28	R/W		reserved.
27-24	R/W	1	reg_mcdi_chkgedgedifsadthd. thd ( $\leq$ ) for sad dif check, 0~8, default = 1
23-16	R/W		reserved.

Bit(s)	R/W	Default	Description
15-12	R/W	15	reg_mcdi_chkedgemaxedgethd. max drt of edge, default = 15
11-8	R/W	2	reg_mcdi_chkedgeminedgethd. min drt of edge, default = 2
7	R/W		reserved.
6-0	R/W	14	reg_mcdi_chkedgevdifthd. thd for vertical dif in check edge, default = 14

Table 9-729 MCDI\_CHK\_EDGE\_GAIN\_OFFST 0x2f0b

Bit(s)	R/W	Default	Description
31-24	R/W		reserved.
23-20	R/W	4	reg_mcdi_chkedgedifthd1. thd1 for edge dif check (<=), default = 4
19-16	R/W	15	reg_mcdi_chkedgedifthd0. thd0 for edge dif check (>=), default = 15
-15	R/W		reserved.
14-10	R/W	24	reg_mcdi_chkedgechklen. total check length for edge check, 1~24 (>0), default = 24
9-8	R/W	1	reg_mcdi_chkedgeedgesel. final edge select mode, 0: original start edge, 1: lpf start edge, 2: original start+end edge, 3: lpf start+end edge, default = 1
7-3	R/W	4	reg_mcdi_chkedgesaddstgain. distance gain for sad calc while getting edges, default = 4
2	R/W		reg_mcdi_chkedgechkmode. edge used in check mode, 0- original edge, 1: lpf edge, default = 1
1	R/W		reg_mcdi_chkedgesstartedge. edge mode for start edge, 0- original edge, 1: lpf edge, default = 0
0	R/W	0	reg_mcdi_chkedgeedgelpf. edge lpf mode, 0-[0,2,4,2,0], 1:[1,2,2,2,1], default = 0

Table 9-730 MCDI\_LMV\_RT0x2f0c

Bit(s)	R/W	Default	Description
31-15	R/W		reserved
14-12	R/W		reg_mcdi_lmvalidmode valid mode for lmv calc., 100b: use char det, 010b: use fft, 001b: use hori flg
11-10	R/W	1	reg_mcdi_lmvgainmvmode four modes of mv selection for lmv weight calucluation, default = 1
// // lst(x-1	R/W		x,x+1); 1- cur(x-4,x-3), lst(x,x+1); 2: cur(x-5,x-4,x-3), lst(x-1,x,x+1,x+2,x+3); 3: cur(x-6,x-5,x-4,x-3), lst(x-1,x,x+1,x+2);
9	R/W	0	reg_mcdi_lmvinitmde initial lmv at first row of input field, 0- initial value = 0; 1: initial = 32 (invalid), default = 0
8	R/W		reserved
7-4	R/W	5	reg_mcdi_lmvr0 ratio of max mv, default = 5
3-0	R/W	5	reg_mcdi_lmvr1 ratio of second max mv, default = 5



**Table 9-731 MCDI\_LMV\_GAINTHD 0x2f0d**

Bit(s)	R/W	Default	Description
31-24	R/W	96	reg_mcdi_lmvsxmaxgain max gain of lmv weight, default = 96
23	R/W		reserved
22-20	R/W	1	reg_mcdi_lmvdifthd0 dif threshold 0 (<) for small lmv, default = 1
19-17	R/W	2	reg_mcdi_lmvdifthd1 dif threshold 1 (<) for median lmv, default = 2
16-14	R/W	3	reg_mcdi_lmvdifthd2 dif threshold 2 (<) for large lmv, default = 3
13-8	R/W	20	reg_mcdi_lmvsnumlmt least/limit number of (total number - max0), default = 20
7-0	R/W	9	reg_mcdi_lmvsfltthd flt cnt thd (<) for lmv, default = 9

**Table 9-732 MCDI\_RPTMV\_THD0 0x2f0e**

Bit(s)	R/W	Default	Description
31-25	R/W	64	reg_mcdi_rptmvslpthd2 slope thd ( $\geq$ ) between $i$ and $i+3/i-3$ ( $i+4/i-4$ ), default = 64
24-20	R/W	4	reg_mcdi_rptmvslpthd1 slope thd ( $\geq$ ) between $i$ and $i+2/i-2$ , default = 4
19-10	R/W	300	reg_mcdi_rptmvampthd2 amplitude thd ( $\geq$ ) between max and min, when count cycles, default = 300
9-0	R/W	400	reg_mcdi_rptmvampthd1 amplitude thd ( $\geq$ ) between average of max and min, default = 400

**Table 9-733 MCDI\_RPTMV\_THD1 0x2f0f**

Bit(s)	R/W	Default	Description
31-28	R/W		reserved
27-25	R/W	2	reg_mcdi_rptmvcycnthd thd ( $\geq$ ) of total cycles count, default = 2
24-21	R/W	3	reg_mcdi_rptmvcycdifthd dif thd (<) of cycles length, default = 3
20-18	R/W	1	reg_mcdi_rptmvcycvldthd thd (>) of valid cycles number, default = 1
17-15	R/W	2	reg_mcdi_rptmvhalfcycminthd min length thd ( $\geq$ ) of half cycle, default = 2
14-11	R/W	5	reg_mcdi_rptmvhalfcycdifthd neighboring half cycle length dif thd (<), default = 5
10-8	R/W	2	reg_mcdi_rptmvminmaxcnthd least number of valid max and min, default = 2
7-5	R/W	2	reg_mcdi_rptmvcycminthd min length thd ( $\geq$ ) of cycles, default = 2
4-0	R/W	17	reg_mcdi_rptmvcycmaxthd max length thd (<) of cycles, default = 17

**Table 9-734 MCDI\_RPTMV\_THD2 0x2f10**

Bit(s)	R/W	Default	Description
31-24	R/W		reserved
23-16	R/W	8	reg_mcdi_rptmvhdifthd0 higher hdif thd ( $\geq$ ) (vertical edge) for rpt detection, default = 8

Bit(s)	R/W	Default	Description
15-8	R/W	4	reg_mcdi_rptmvhdifthd1 hdif thd ( $\geq$ ) (slope edge) for rpt detection, default = 4
7-0	R/W	1	reg_mcdi_rptmvvdifthd vdif thd ( $\geq$ ) (slope edge) for rpt detection, default = 1

Table 9-735 MCDI\_RPTMV\_SAD 0x2f11

Bit(s)	R/W	Default	Description
31-26	R/W		reserved
25-16	R/W	336	reg_mcdi_rptmvsaddifthdgain 7x3x(16/16), gain for sad dif thd in rpt mv detection, 0~672, normalized 16 as '1', default = 336
15-10	R/W		reserved
9-0	R/W	16	reg_mcdi_rptmvsaddifthdoffst offset for sad dif thd in rpt mv detection, -512~511, default = 16

Table 9-736 MCDI\_RPTMV\_FLG 0x2f12

Bit(s)	R/W	Default	Description
31-18	R/W		reserved
17-16	R/W	2	reg_mcdi_rptmvmode select mode of mvs for repeat motion estimation, 0: hmv, 1: qmv/2, 2 or 3: qmv/4, default = 2
15-8	R/W	64	reg_mcdi_rptmvflgcntthd thd ( $\geq$ ) of min count number for rptmv of whole field, for rptmv estimation, default = 64
7-5	R/W		reserved
4-0	R/W		reg_mcdi_rptmvflgcntrt 4/32, ratio for repeat mv flag count, normalized 32 as '1', set 31 to 32,

Table 9-737 MCDI\_RPTMV\_GAIN 0x2f13

Bit(s)	R/W	Default	Description
31-24	R/W	96	reg_mcdi_rptmvlftgain up repeat mv gain for hme, default = 96
23-16	R/W	32	reg_mcdi_rptmvuplftgain up left repeat mv gain for hme, default = 32
15-8	R/W	64	reg_mcdi_rptmvupgain up repeat mv gain for hme, default = 64
7-0	R/W	32	reg_mcdi_rptmvuprightgain up right repeat mv gain for hme, default = 32

Table 9-738 MCDI\_GMV\_RT0x2f14

Bit(s)	R/W	Default	Description
31	R/W		reserved
30-24	R/W	32	reg_mcdi_gmvmtnr0 ratio 0 for motion senario, set 127 to 128, normalized 128 as '1', default =32
23	R/W		reserved
22-16	R/W	56	reg_mcdi_gmvmtnr1 ratio 1 for motion senario, set 127 to 128, normalized 128 as '1', default = 56

Bit(s)	R/W	Default	Description
15	R/W		reserved
14-8	R/W	56	reg_mcdi_gmvstlrt0 ratio 0 for still senario, set 127 to 128, normalized 128 as '1', default = 56
7	R/W		reserved
6-0	R/W	80	reg_mcdi_gmvstlrt1 ratio 1 for still senario, set 127 to 128, normalized 128 as '1', default = 80

Table 9-739 MCDI\_GMV\_GAIN 0x2f15

Bit(s)	R/W	Default	Description
31-25	R/W	100	reg_mcdi_gmvzeromvlockrt0 ratio 0 for locking zero mv, set 127 to 128, normalized 128 as '1', default = 100
24-18	R/W	112	reg_mcdi_gmvzeromvlockrt1 ratio 1 for locking zero mv, set 127 to 128, normalized 128 as '1', default = 112
17-16	R/W	3	reg_mcdi_gmvvalidmode valid mode for gmv calc., 10b: use flt, 01b: use hori flg, default = 3
15-8	R/W	0	reg_mcdi_gmvvxgain gmv's vx gain when gmv locked for hme, default = 0
7-0	R/W	3	reg_mcdi_gmvfltthd flat thd (<) for gmv calc. default = 3

Table 9-740 MCDI\_HOR\_SADOFST 0x2f16

Bit(s)	R/W	Default	Description
31-25	R/W		reserved
24-16	R/W	21	reg_mcdi_horsaddiftdgain 21*1/8, gain/divisor for sad dif threshold in hor line detection, normalized 8 as '1', default = 21
15-8	R/W	0	reg_mcdi_horsaddiftdoffst offset for sad dif threshold in hor line detection, -128~127, default = 0
7-0	R/W	24	reg_mcdi_horvdiftd threshold (>=) of vertical dif of next block for horizontal line detection, default = 24

Table 9-741 MCDI\_REF\_MV\_NUM 0x2f17

Bit(s)	R/W	Default	Description
31-2	R/W		reserved
1-0	R/W	0	reg_mcdi_refmcmode. motion compensated mode used in refinement, 0: pre, 1: next, 2: (pre+next)/2, default = 0

Table 9-742 MCDI\_REF\_BADW\_THD\_GAIN0x2f18

Bit(s)	R/W	Default	Description
31-28	R/W		reserved
27-24	R/W	6	reg_mcdi_refbadwcnt2gain. gain for badwv count num==3, default = 6
23-20	R/W	3	reg_mcdi_refbadwcnt1gain. gain for badwv count num==2, default = 3
19-16	R/W	1	reg_mcdi_refbadwcnt0gain. gain for badwv count num==1, default = 1

Bit(s)	R/W	Default	Description
15-12	R/W	4	reg_mcdi_refbadwthd3. threshold 3 for detect badweave with largest average luma, default = 4
11-8	R/W	3	reg_mcdi_refbadwthd2. threshold 2 for detect badweave with third smallest average luma, default = 3
7-4	R/W	2	reg_mcdi_refbadwthd1. threshold 1 for detect badweave with second smallest average luma, default = 2
3-0	R/W	1	reg_mcdi_refbadwthd0. threshold 0 for detect badweave with smallest average luma, default = 1

Table 9-743 MCDI\_REF\_BADW\_SUM\_GAIN0x2f19

Bit(s)	R/W	Default	Description
31-13	R/W		reserved
12-8	R/W	8	reg_mcdi_refbadwsumgain0. sum gain for r channel, 0~16, default = 8
7-5	R/W		reserved
4	R/W	0	reg_mcdi_refbadwcalcmode. mode for badw calculation, 0-sum, 1:max, default = 0
3-0	R/W		reserved

Table 9-744 MCDI\_REF\_BS\_THD\_GAIN 0x2f1a

Bit(s)	R/W	Default	Description
31-28	R/W	2	reg_mcdi_refbsudgain1. up & down block strength gain1, normalized to 8 as '1', default = 2
27-24	R/W	4	reg_mcdi_refbsudgain0. up & down block strength gain0, normalized to 8 as '1', default = 4
23-19	R/W		reserved
18-16	R/W	0	reg_mcdi_refbslftgain. left block strength gain, default = 0
15-13	R/W		reserved
12-8	R/W	16	reg_mcdi_refbsthd1. threshold 1 for detect block strength in refinement, default = 16
7-5	R/W		reserved
4-0	R/W	8	reg_mcdi_refbsthd0. threshold 0 for detect block strength in refinement, default = 8

Table 9-745 MCDI\_REF\_ERR\_GAIN0 0x2f1b

Bit(s)	R/W	Default	Description
31	R/W		reserved
30-24	R/W	48	reg_mcdi_referrnbrdstgain. neighoring mv distances gain for err calc. in ref, normalized to 8 as '1', default = 48
23-20	R/W		reserved
19-16	R/W	4	reg_mcdi_referrbsgain. bs gain for err calc. in ref, normalized to 8 as '1', default = 4

Bit(s)	R/W	Default	Description
15	R/W		reserved
14-8	R/W	64	reg_mcdi_referrbadwgain. badw gain for err calc. in ref, normalized to 8 as '1', default = 64
7-4	R/W		reserved
3-0	R/W	4	reg_mcdi_referrsadgain. sad gain for err calc. in ref, normalized to 8 as '1', default = 4

Table 9-746 MCDI\_REF\_ERR\_GAIN1 0x2f1c

Bit(s)	R/W	Default	Description
31-20	R/W		reserved
19-16	R/W	4	reg_mcdi_referrchkegegain. check edge gain for err calc. in ref, normalized to 8 as '1', default = 4
15-12	R/W		reserved
11-8	R/W	0	reg_mcdi_referrlmvgain. (locked) lmv gain for err calc. in ref, normalized to 8 as '1', default = 0
7-4	R/W		reserved
3-0	R/W	0	reg_mcdi_referrgmvgain. (locked) gmvgain for err calc. in ref, normalized to 8 as '1', default = 0

Table 9-747 MCDI\_REF\_ERR\_FRQ\_CHK 0x2f1d

Bit(s)	R/W	Default	Description
31-28	R/W		reserved
27-24	R/W	10	reg_mcdi_referrfrqgain. gain for mv frequency, normalized to 4 as '1', default = 10
23-21	R/W		reserved
20-16	R/W	31	reg_mcdi_referrfrqmax. max gain for mv frequency check, default = 31
15	R/W		reserved
14-12	R/W	3	reg_mcdi_ref_errfrqmdifhd2. mv dif threshold 2 (<) for mv frequency check, default = 3
11	R/W		reserved
10-8	R/W	2	reg_mcdi_ref_errfrqmdifhd1. mv dif threshold 1 (<) for mv frequency check, default = 2
7	R/W		reserved
6-4	R/W	1	reg_mcdi_ref_errfrqmdifhd0. mv dif threshold 0 (<) for mv frequency check, default = 1
3-0	R/W		reserved

**Table 9-748 MCDI\_QME\_LPF\_MSK 0x2f1e**

Bit(s)	R/W	Default	Description
31-28	R/W		reserved
27-24	R/W	7	reg_mcdi_qmechkedgelpfmsk0. lpf mask0 for chk edge in qme, 0~8, msk1 = (8-msk0), normalized to 8 as '1', default = 7
23-20	R/W		reserved
19-16	R/W	7	reg_mcdi_qmebslpfmsk0. lpf mask0 for bs in qme, 0~8, msk1 = (8-msk0), normalized to 8 as '1', default = 7
15-12	R/W		reserved
11-8	R/W	7	reg_mcdi_qmebadwlpfmsk0. lpf mask0 for badw in qme, 0~8, msk1 = (8-msk0), normalized to 8 as '1', default = 7
7-4	R/W		reserved
3-0	R/W	7	reg_mcdi_qmesadlpfmsk0. lpf mask0 for sad in qme, 0~8, msk1 = (8-msk0), normalized to 8 as '1', default = 7

**Table 9-749 MCDI\_REL\_DIF\_THD\_02 0x2f1f**

Bit(s)	R/W	Default	Description
31-24	R/W		reserved.
23-16	R/W	9	reg_mcdi_reldifhd2. thd (<) for (hdif+vdif), default = 9
15-8	R/W	5	reg_mcdi_reldifhd1. thd (<) for (vdif), default = 5
7-0	R/W	48	reg_mcdi_reldifhd0. thd (>=) for (hdif-vdif), default = 48

**Table 9-750 MCDI\_REL\_DIF\_THD\_34 0x2f20**

Bit(s)	R/W	Default	Description
31-16	R/W		reserved.
15-8	R/W	255	reg_mcdi_reldifhd4. thd (<) for (hdif), default = 255
7-0	R/W	48	reg_mcdi_reldifhd3. thd (>=) for (vdif-hdif), default = 48

**Table 9-751 MCDI\_REL\_BADW\_GAIN\_OFFST\_01 0x2f21**

Bit(s)	R/W	Default	Description
31-24	R/W	0	reg_mcdi_relbawoffst1. offset for badw adj, for flat block, -128~127, default = 0
23-16	R/W	128	reg_mcdi_relbawgain1. gain for badw adj, for flat block, default = 128
15-8	R/W	0	reg_mcdi_relbawoffst0. offset for badw adj, for vertical block, -128~127, default = 0
7-0	R/W	160	reg_mcdi_relbawgain0. gain for badw adj, for vertical block, default = 160

**Table 9-752 MCDI\_REL\_BADW\_GAIN\_OFFST\_23 0x2f22**

Bit(s)	R/W	Default	Description
31-24	R/W	0	reg_mcdi_relbawoffst3. offset for badw adj, for other block, -128~127, default = 0
23-16	R/W	48	reg_mcdi_relbawgain3. gain for badw adj, for other block, default = 48
15-8	R/W	0	reg_mcdi_relbawoffst2. offset for badw adj, for horizontal block, -128~127, default = 0
7-0	R/W	48	reg_mcdi_relbawgain2. gain for badw adj, for horizontal block, default = 48

**Table 9-753 MCDI\_REL\_BADW\_THD\_GAIN\_OFFST 0x2f23**

Bit(s)	R/W	Default	Description
31-23	R/W		reserved.
22-16	R/W	0	reg_mcdi_relbawthdoffst. offset for badw thd adj, -64~63, default = 0
15-8	R/W		reserved.
7-0	R/W	16	reg_mcdi_relbawthdgain. gain0 for badw thd adj, normalized to 16 as '1', default = 16

**Table 9-754 MCDI\_REL\_BADW\_THD\_MIN\_MAX 0x2f24**

Bit(s)	R/W	Default	Description
31-18	R/W		reserved.
17-8	R/W	256	reg_mcdi_relbawthdmax. max for badw thd adj, default = 256
7-0	R/W	16	reg_mcdi_relbawthdmin. min for badw thd adj, default = 16

**Table 9-755 MCDI\_REL\_SAD\_GAIN\_OFFST\_01 0x2f25**

Bit(s)	R/W	Default	Description
31-24	R/W	0	reg_mcdi_relsadoffst1. offset for sad adj, for flat block, -128~127, default = 0
23-20	R/W		reserved.
19-16	R/W	8	reg_mcdi_relsadgain1. gain for sad adj, for flat block, normalized to 8 as '1', default = 8
15-8	R/W	0	reg_mcdi_relsadoffst0. offset for sad adj, for vertical block, -128~127, default = 0
7-4	R/W		reserved.
3-0	R/W	6	reg_mcdi_relsadgain0. gain for sad adj, for vertical block, normalized to 8 as '1', default = 6

**Table 9-756 MCDI\_REL\_SAD\_GAIN\_OFFST\_23 0x2f26**

Bit(s)	R/W	Default	Description
31-24	R/W	0	reg_mcdi_relsadoffst3. offset for sad adj, for other block, -128~127, default = 0
23-20	R/W		reserved.

Bit(s)	R/W	Default	Description
19-16	R/W	8	reg_mcdi_relsadgain3. gain for sad adj, for other block, normalized to 8 as '1', default = 8
15-8	R/W	0	reg_mcdi_relsadoffst2. offset for sad adj, for horizontal block, -128~127, default = 0
7-4	R/W		reserved.
3-0	R/W	12	reg_mcdi_relsadgain2. gain for sad adj, for horizontal block, normalized to 8 as '1', default = 12

Table 9-757 MCDI\_REL\_SAD\_THD\_GAIN\_OFFST 0x2f27

Bit(s)	R/W	Default	Description
31-24	R/W		reserved.
23-16	R/W	0	reg_mcdi_relsadoffst. offset for sad thd adj, -128~127, default = 0
15-10	R/W		reserved.
9-0	R/W	42	reg_mcdi_relsadthdgain. gain for sad thd adj, $21 \times 2 / 16$ , normalized to 16 as '1', default = 42

Table 9-758 MCDI\_REL\_SAD\_THD\_MIN\_MAX 0x2f28

Bit(s)	R/W	Default	Description
31-27	R/W		reserved.
26-16	R/W	672	reg_mcdi_relsadthdmax. max for sad thd adj, $21 \times 32$ , default = 672
15-9	R/W		reserved.
8-0	R/W	42	reg_mcdi_relsadthdmin. min for sad thd adj, $21 \times 2$ , default = 42

Table 9-759 MCDI\_REL\_DET\_GAIN\_00 0x2f29

Bit(s)	R/W	Default	Description
31-21	R/W		reserved.
20-16	R/W	8	reg_mcdi_reldetbsgain0. gain0 (gmv locked) for bs, for det. calc. normalized to 16 as '1', default = 8
15-14	R/W		reserved.
13-8	R/W	12	reg_mcdi_reldetbadwgain0. gain0 (gmv locked) for badw, for det. calc. normalized to 16 as '1', default = 12
7-5	R/W		reserved.
4-0	R/W	8	reg_mcdi_reldetsadgain0. gain0 (gmv locked) for qsad, for det. calc. normalized to 16 as '1', default = 8



**Table 9-760 MCDI\_REL\_DET\_GAIN\_01 0x2f2a**

Bit(s)	R/W	Default	Description
31-14	R/W		reserved.
12-8	R/W	2	reg_mcdi_reldetchkedg0. gain0 (gmv locked) for chk_edge, for det. calc. normalized to 16 as '1', default = 2
7	R/W		reserved.
6-0	R/W	24	reg_mcdi_reldetnbrdstg0. gain0 (gmv locked) for neighoring dist, for det. calc. normalized to 16 as '1', default = 24

**Table 9-761 MCDI\_REL\_DET\_GAIN\_10 0x2f2b**

Bit(s)	R/W	Default	Description
31-21	R/W		reserved.
20-16	R/W	0	reg_mcdi_reldetbsgain1. gain1 (lmv locked) for bs, for det. calc. normalized to 16 as '1', default = 0
15-14	R/W		reserved.
13-8	R/W	8	reg_mcdi_reldetbadwgain1. gain1 (lmv locked) for badw, for det. calc. normalized to 16 as '1', default = 8
7-5	R/W		reserved.
4-0	R/W	8	reg_mcdi_reldetsadgain1. gain1 (lmv locked) for qsad, for det. calc. normalized to 16 as '1', default = 8

**Table 9-762 MCDI\_REL\_DET\_GAIN\_11 0x2f2c**

Bit(s)	R/W	Default	Description
31-14	R/W		reserved.
12-8	R/W	0	reg_mcdi_reldetchkedg1. gain1 (lmv locked) for chk_edge, for det. calc. normalized to 16 as '1', default = 0
7	R/W		reserved.
6-0	R/W	24	reg_mcdi_reldetnbrdstg1. gain1 (lmv locked) for neighoring dist, for det. calc. normalized to 16 as '1', default = 24

**Table 9-763 MCDI\_REL\_DET\_GAIN\_20 0x2f2d**

Bit(s)	R/W	Default	Description
31-21	R/W		reserved.
20-16	R/W	12	reg_mcdi_reldetbsgain2. gain2 (no locked) for bs, for det. calc. normalized to 16 as '1', default = 12
15-14	R/W		reserved.
13-8	R/W	32	reg_mcdi_reldetbadwgain2. gain2 (no locked) for badw, for det. calc. normalized to 16 as '1', default = 32
7-5	R/W		reserved.
4-0	R/W	16	reg_mcdi_reldetsadgain2. gain2 (no locked) for qsad, for det. calc. normalized to 16 as '1', default = 16

Table 9-764 MCDI\_REL\_DET\_GAIN\_21 0x2f2e

Bit(s)	R/W	Default	Description
31-26	R/W		reserved
25-16	R/W	0	reg_mcdi_reldetoffst. offset for rel calculation, for det. calc. -512~511, default = 0
15-14	R/W		reserved.
12-8	R/W	10	reg_mcdi_reldetchkedgegain2. gain2 (no locked) for chk_edge, for det. calc. normalized to 16 as '1', default = 10
7	R/W		reserved.
6-0	R/W	32	reg_mcdi_reldetnbrdstgain2. gain2 (no locked) for neighoring dist, for det. calc. normalized to 16 as '1', default = 32

Table 9-765 MCDI\_REL\_DET\_GMV\_DIF\_CHK 0x2f2f

Bit(s)	R/W	Default	Description
31-24	R/W		reserved.
23-16	R/W	0	reg_mcdi_reldetgmvlthd. flat thd ( $\geq$ ) for gmV lock decision, default = 0
15	R/W		reserved.
14-12	R/W	3	reg_mcdi_reldetgmvdifthd. dif thd ( $\geq$ ) for current mv different from gmV for gmV dif check, actually used in Lmv lock check, default = 3
11	R/W		reserved.
10-8	R/W	1	reg_mcdi_reldetgmvdifmin. min mv dif for gmV dif check, default = 1, note: dif between reg_mcdi_rel_det_gmv_dif_max and reg_mcdi_rel_det_gmv_dif_min should be; 0,1,3,7, not work for others
7-4	R/W	4	reg_mcdi_reldetgmvdifmax. max mv dif for gmV dif check, default = 4
3-1	R/W		reserved
0	R/W	0	reg_mcdi_reldetgmvdifmvmode. mv mode used for gmV dif check, 0- use refmv, 1: use qmv, default = 0

Table 9-766 MCDI\_REL\_DET\_LMV\_DIF\_CHK 0x2f30

Bit(s)	R/W	Default	Description
31-24	R/W		reserved.
23-16	R/W	12	reg_mcdi_reldetlmvflthd. flat thd ( $\geq$ ) for lmv lock decision, default = 12
15-14	R/W		reserved.
13-12	R/W	1	reg_mcdi_reldetlmvlockchkmode. lmv lock check mode, 0:cur Lmv, 1: cur & (last   next), 2: last & cur & next Lmv, default = 1
11	R/W		reserved.
10-8	R/W	1	reg_mcdi_reldetlmvdifmin. min mv dif for lmv dif check, default = 1, note: dif between reg_mcdi_rel_det_lmv_dif_max and reg_mcdi_rel_det_lmv_dif_min should be; 0,1,3,7, not work for others
7-4	R/W	4	reg_mcdi_reldetlmvdifmax. max mv dif for lmv dif check, default = 4

Bit(s)	R/W	Default	Description
3-1	R/W		reserved
0	R/W	0	reg_mcdi_reldetlmvdfimvmode. mv mode used for lmv dif check, 0- use refmv, 1: use qmv, default = 0

Table 9-767 MCDI\_REL\_DET\_FRQ\_CHK 0x2f31

Bit(s)	R/W	Default	Description
31-12	R/W		reserved.
11-8	R/W	10	reg_mcdi_reldetfrqgain. gain for frequency check, normalized to 4 as '1', default = 10
7-5	R/W		reserved
4-0	R/W	31	reg_mcdi_reldetfrqmax. max value for frequency check, default = 31

Table 9-768 MCDI\_REL\_DET\_PD22\_CHK 0x2f32

Bit(s)	R/W	Default	Description
31-18	R/W		reserved.
30-21	R/W	512	reg_mcdi_reldetpd22chkoffst1. offset for pd22 check happened, default = 512
20-16	R/W	12	reg_mcdi_reldetpd22chkgain1. gain for pd22 check happened, normalized to 8 as '1', default = 12
14-5	R/W	512	reg_mcdi_reldetpd22chkoffst0. offset for pd22 check happened, default = 512
4-0	R/W	12	reg_mcdi_reldetpd22chkgain0. gain for pd22 check happened, normalized to 8 as '1', default = 12

Table 9-769 MCDI\_REL\_DET\_RPT\_CHK\_ROW 0x2f33

Bit(s)	R/W	Default	Description
31-27	R/W		reserved
26-16	R/W	2047	reg_mcdi_reldetrptchkendrow. end row (<) number for repeat check, default = 2047
15-11	R/W		reserved
10-0	R/W	0	reg_mcdi_reldetrptchkstartrow. start row (>=) number for repeat check, default = 0

Table 9-770 MCDI\_REL\_DET\_RPT\_CHK\_GAIN\_QMV 0x2f34

Bit(s)	R/W	Default	Description
31-30	R/W		reserved
29-24	R/W	15	reg_mcdi_reldetrptchkqmvmax. max thd (<) of abs qmv for repeat check, default = 15, note that quarter mv's range is -63~63
23-22	R/W		reserved
21-16	R/W	10	reg_mcdi_reldetrptchkqmvmin. min thd (>=) of abs qmv for repeat check, default = 10, note that quarter mv's range is -63~63

Bit(s)	R/W	Default	Description
15	R/W		reserved/
14-4	R/W	512	reg_mcdi_reldetrptchkoffst. offset for repeat check, default = 512
3-0	R/W	4	reg_mcdi_reldetrptchkgain. gain for repeat check, normalized to 8 as '1', default = 4

Table 9-771 MCDI\_REL\_DET\_RPT\_CHK\_THD\_0 0x2f35

Bit(s)	R/W	Default	Description
31-24	R/W		reserved
23-16	R/W	255	reg_mcdi_reldetrptchkzerosadthd. zero sad thd (<) for repeat check, default = 255
15-14	R/W		reserved.
13-8	R/W	16	reg_mcdi_reldetrptchkzerobadwthd. zero badw thd (>=) for repeat check, default = 16
7-4	R/W		reserved
3-0	R/W	5	reg_mcdi_reldetrptchkfrqdifthd. frequency dif thd (<) for repeat check, 0~10, default = 5

Table 9-772 MCDI\_REL\_DET\_RPT\_CHK\_THD\_1 0x2f36

Bit(s)	R/W	Default	Description
31-16	R/W		reserved
15-8	R/W	16	reg_mcdi_reldetrptchkvdifthd. vertical dif thd (<) for repeat check, default = 16
7-0	R/W	16	reg_mcdi_reldetrptchkhdifthd. horizontal dif thd (>=) for repeat check, default = 16

Table 9-773 MCDI\_REL\_DET\_LPF\_DIF\_THD 0x2f37

Bit(s)	R/W	Default	Description
31-24	R/W	9	reg_mcdi_reldetlpdifthd3. hdif thd (<) for lpf selection of horizontal block, default = 9
23-16	R/W	48	reg_mcdi_reldetlpdifthd2. vdif-hdif thd (>=) for lpf selection of horizontal block, default = 48
15-8	R/W	9	reg_mcdi_reldetlpdifthd1. vdif thd (<) for lpf selection of vertical block, default = 9
7-0	R/W	48	reg_mcdi_reldetlpdifthd0. hdif-vdif thd (>=) for lpf selection of vertical block, default = 48

Table 9-774 MCDI\_REL\_DET\_LPF\_MSK\_00\_03 0x2f38

Bit(s)	R/W	Default	Description
31-29	R/W		reserved
28-24	R/W	1	reg_mcdi_reldetlpfmsk03. det lpf mask03 for gmv/lmv locked mode, 0~16, default = 1

Bit(s)	R/W	Default	Description
23-21	R/W		reserved
20-16	R/W	1	reg_mcdi_reldetlpfmsk02. det lpf mask02 for gmv/lmv locked mode, 0~16, default = 1
15-13	R/W		reserved
12-8	R/W	5	reg_mcdi_reldetlpfmsk01. det lpf mask01 for gmv/lmv locked mode, 0~16, default = 5
7-5	R/W		reserved
4-0	R/W	8	reg_mcdi_reldetlpfmsk00. det lpf mask00 for gmv/lmv locked mode, 0~16, default = 8

Table 9-775 MCDI\_REL\_DET\_LPF\_MSK\_04\_12 0x2f39

Bit(s)	R/W	Default	Description
31-29	R/W		reserved
28-24	R/W	0	reg_mcdi_reldetlpfmsk12. det lpf mask12 for vertical blocks, 0~16, default = 0
23-21	R/W		reserved
20-16	R/W	0	reg_mcdi_reldetlpfmsk11. det lpf mask11 for vertical blocks, 0~16, default = 0
15-13	R/W		reserved
12-8	R/W	16	reg_mcdi_reldetlpfmsk10. det lpf mask10 for vertical blocks, 0~16, default = 16
7-5	R/W		reserved
4-0	R/W	1	reg_mcdi_reldetlpfmsk04. det lpf mask04 for gmv/lmv locked mode, 0~16, default = 1

Table 9-776 MCDI\_REL\_DET\_LPF\_MSK\_13\_21 0x2f3a

Bit(s)	R/W	Default	Description
31-29	R/W		reserved
28-24	R/W	6	reg_mcdi_reldetlpfmsk21. det lpf mask21 for horizontal blocks, 0~16, default = 6
23-21	R/W		reserved
20-16	R/W	8	reg_mcdi_reldetlpfmsk20. det lpf mask20 for horizontal blocks, 0~16, default = 8
15-13	R/W		reserved
12-8	R/W	0	reg_mcdi_reldetlpfmsk14. det lpf mask14 for vertical blocks, 0~16, default = 0
7-5	R/W		reserved
4-0	R/W	0	reg_mcdi_reldetlpfmsk13. det lpf mask13 for vertical blocks, 0~16, default = 0

Table 9-777 MCDI\_REL\_DET\_LPF\_MSK\_22\_30 0x2f3b

Bit(s)	R/W	Default	Description
31-29	R/W		reserved
28-24	R/W	16	reg_mcdi_reldetlpfmsk30. det lpf mask30 for other blocks, 0~16, default = 16

Bit(s)	R/W	Default	Description
23-21	R/W		reserved
20-16	R/W	1	reg_mcdi_reldetlpfmsk24. det lpf mask24 for horizontal blocks, 0~16, default = 1
15-13	R/W		reserved
12-8	R/W	0	reg_mcdi_reldetlpfmsk23. det lpf mask23 for horizontal blocks, 0~16, default = 0
7-5	R/W		reserved
4-0	R/W	1	reg_mcdi_reldetlpfmsk22. det lpf mask22 for horizontal blocks, 0~16, default = 1

Table 9-778 MCDI\_REL\_DET\_LPF\_MSK\_31\_34 0x2f3c

Bit(s)	R/W	Default	Description
31-29	R/W		reserved
28-24	R/W	0	reg_mcdi_reldetlpfmsk34. det lpf mask34 for other blocks, 0~16, default = 0
23-21	R/W		reserved
20-16	R/W	0	reg_mcdi_reldetlpfmsk33. det lpf mask33 for other blocks, 0~16, default = 0
15-13	R/W		reserved
12-8	R/W	0	reg_mcdi_reldetlpfmsk32. det lpf mask32 for other blocks, 0~16, default = 0
7-5	R/W		reserved
4-0	R/W	0	reg_mcdi_reldetlpfmsk31. det lpf mask31 for other blocks, 0~16, default = 0

Table 9-779 MCDI\_REL\_DET\_MIN 0x2f3d

Bit(s)	R/W	Default	Description
31-7	R/W		reserved
6-0	R/W	16	reg_mcdi_reldetmin. min of detected value, default = 16

Table 9-780 MCDI\_REL\_DET\_LUT\_0\_3 0x2f3e

Bit(s)	R/W	Default	Description
31-24	R/W	8	reg_mcdi_reldetmaplut3. default = 8
23-16	R/W	4	reg_mcdi_reldetmaplut2. default = 4
15-8	R/W	2	reg_mcdi_reldetmaplut1. default = 2
7-0	R/W	0	reg_mcdi_reldetmaplut0. default = 0

Table 9-781 MCDI\_REL\_DET\_LUT\_4\_7 0x2f3f

Bit(s)	R/W	Default	Description
31-24	R/W	64	reg_mcdi_reldetmaplut7. default = 64
23-16	R/W	48	reg_mcdi_reldetmaplut6. default = 48

Bit(s)	R/W	Default	Description
15-8	R/W	32	reg_mcdi_reldetmaplut5. default = 32
7-0	R/W	16	reg_mcdi_reldetmaplut4. default = 16

Table 9-782 MCDI\_REL\_DET\_LUT\_8\_11 0x2f40

Bit(s)	R/W	Default	Description
31-24	R/W	160	reg_mcdi_reldetmaplut11. default = 160
23-16	R/W	128	reg_mcdi_reldetmaplut10. default = 128
15-8	R/W	96	reg_mcdi_reldetmaplut9. default = 96
7-0	R/W	80	reg_mcdi_reldetmaplut8. default = 80

Table 9-783 MCDI\_REL\_DET\_LUT\_12\_150x2f41

Bit(s)	R/W	Default	Description
31-24	R/W	255	reg_mcdi_reldetmaplut15. default = 255
23-16	R/W	240	reg_mcdi_reldetmaplut14. default = 240
15-8	R/W	224	reg_mcdi_reldetmaplut13. default = 224
7-0	R/W	192	reg_mcdi_reldetmaplut12. default = 192

Table 9-784 MCDI\_REL\_DET\_COL\_CFD\_THD 0x2f42

Bit(s)	R/W	Default	Description
31-24	R/W	5	reg_mcdi_reldetcolcfdfthd. thd for flat smaller than (<) of column cofidence, default = 5
23-16	R/W	160	reg_mcdi_reldetcolcfdthd1. thd for rel larger than (>=) in rel calc. mode col confidence without gmv locking, default = 160
15-8	R/W	100	reg_mcdi_reldetcolcfdthd0. thd for rel larger than (>=) in rel calc. mode col confidence when gmv locked, default = 100
7-2	R/W	16	reg_mcdi_reldetcolcfdbadwthd. thd for badw larger than (>=) in qbadw calc. mode of column cofidence, default = 16
1	R/W		reserved
0	R/W	0	reg_mcdi_reldetcolcfdcalcmode. calc. mode for column cofidence, 0- use rel, 1: use qbadw, default = 0

Table 9-785 MCDI\_REL\_DET\_COL\_CFD\_AVG\_LUMA 0x2f43

Bit(s)	R/W	Default	Description
31-24	R/W	235	reg_mcdi_reldetcolcfdavgmin1. avg luma min1 (>=) for column cofidence, valid between 16~235, default = 235
23-16	R/W	235	reg_mcdi_reldetcolcfdavgmax1. avg luma max1 (<) for column cofidence, valid between 16~235, default = 235

Bit(s)	R/W	Default	Description
15-8	R/W	16	reg_mcdi_reldetcolcfavgmin0. avg luma min0 ( $\geq$ ) for column confidence, valid between 16~235, default = 16
7-0	R/W	21	reg_mcdi_reldetcolcfavgmax0. avg luma max0 ( $<$ ) for column confidence, valid between 16~235, default = 21

Table 9-786 MCDI\_REL\_DET\_BAD\_THD\_00x2f44

Bit(s)	R/W	Default	Description
31-16	R/W		reserved
15-8	R/W	120	reg_mcdi_reldetbadsadthd. thd ( $\geq$ ) for bad sad, default = 120 (480/4)
7-6	R/W		reserved
5-0	R/W	12	reg_mcdi_reldetbadbadwthd. thd ( $\geq$ ) for bad badw, 0~42, default = 12

Table 9-787 MCDI\_REL\_DET\_BAD\_THD\_10x2f45

Bit(s)	R/W	Default	Description
31-24	R/W		reserved
23-16	R/W	4	reg_mcdi_reldetbadrelflthd. thd ( $\geq$ ) of flat for bad rel detection, default = 4
15-8	R/W	160	reg_mcdi_reldetbadrelthd1. thd ( $\geq$ ) for bad rel without gmv/lmv locked, default = 160
7-0	R/W	120	reg_mcdi_reldetbadrelthd0. thd ( $\geq$ ) for bad rel with gmv/lmv locked, default = 120

Table 9-788 MCDI\_PD22\_CHK\_THD 0x2f46

Bit(s)	R/W	Default	Description
31-25	R/W		reserved
24-16	R/W	64	reg_mcdi_pd22chksaddifthd. sad dif thd ( $\geq$ ) for (pd22chksad - qsad) for pd22 check, default = 64
15-14	R/W		reserved
13-8	R/W	2	reg_mcdi_pd22chkqmvthd. thd ( $\geq$ ) of abs qmv for pd22 check, default = 2
7-0	R/W	4	reg_mcdi_pd22chkflthd. thd ( $\geq$ ) of flat for pd22 check, default = 4

Table 9-789 MCDI\_PD22\_CHK\_GAIN\_OFFST\_0 0x2f47

Bit(s)	R/W	Default	Description
31-24	R/W	0	reg_mcdi_pd22chkedgeoffst0. offset0 of pd22chkedge from right film22 phase, -128~127, default = 0
23-21	R/W		reserved
20-16	R/W	16	reg_mcdi_pd22chkedgegain0. gain0 of pd22chkedge from right film22 phase, normalized to 16 as '1', default = 16
15-12	R/W		reserved



Bit(s)	R/W	Default	Description
11-8	R/W	0	reg_mcdi_pd22chkbadwoffst0. offset0 of pd22chkbadw from right film22 phase, -8~7, default = 0
7-5	R/W		reserved
4-0	R/W	8	reg_mcdi_pd22chkbadwgain0. gain0 of pd22chkbadw from right film22 phase, normalized to 16 as '1', default = 8

Table 9-790 MCDI\_PD22\_CHK\_GAIN\_OFFST\_1 0x2f48

Bit(s)	R/W	Default	Description
31-24	R/W	0	reg_mcdi_pd22chkedgeoffst1. offset1 of pd22chkedge from right film22 phase, -128~127, default = 0
23-21	R/W		reserved
20-16	R/W	16	reg_mcdi_pd22chkedgegain1. gain1 of pd22chkedge from right film22 phase, normalized to 16 as '1', default = 16
15-12	R/W		reserved
11-8	R/W	0	reg_mcdi_pd22chkbadwoffst1. offset1 of pd22chkbadw from right film22 phase, -8~7, default = 0
7-5	R/W		reserved
4-0	R/W	12	reg_mcdi_pd22chkbadwgain1. gain1 of pd22chkbadw from right film22 phase, normalized to 16 as '1', default = 12

Table 9-791 MCDI\_LMV\_LOCK\_CNT\_THD\_GAIN 0x2f49

Bit(s)	R/W	Default	Description
31-20	R/W		reserved
19-16	R/W	6	reg_mcdi_lmvlckcntmax. max lmv lock count number, default = 6
15-12	R/W	0	reg_mcdi_lmvlckcntoffst. offset for lmv lock count, -8~7, default = 0
11-8	R/W	8	reg_mcdi_lmvlckcntgain. gain for lmv lock count, normalized 8 as '1', 15 is set to 16, default = 8
7-5	R/W		reserved
4-0	R/W	4	reg_mcdi_lmvlckcntthd. lmv count thd (>=) before be locked, 1~31, default = 4

Table 9-792 MCDI\_LMV\_LOCK\_ABS\_DIF\_THD 0x2f4a

Bit(s)	R/W	Default	Description
31-27	R/W		reserved
26-24	R/W	1	reg_mcdi_lmvlckdifthd2. lmv dif thd for third part, before locked, default = 1
23	R/W		reserved
22-20	R/W	1	reg_mcdi_lmvlckdifthd1. lmv dif thd for second part, before locked, default = 1
19	R/W		reserved
18-16	R/W	1	reg_mcdi_lmvlckdifthd0. lmv dif thd for first part, before locked, default = 1

Bit(s)	R/W	Default	Description
15-13	R/W		reserved
12-8	R/W	24	reg_mcdi_lmvlckabsmax. max abs (<) of lmv to be locked, default = 24
7-5	R/W		reserved
4-0	R/W	1	reg_mcdi_lmvlckabsmin. min abs (>=) of lmv to be locked, default = 1

Table 9-793 MCDI\_LMV\_LOCK\_ROW 0x2f4b

Bit(s)	R/W	Default	Description
31-27	R/W		reserved
26-16	R/W	2047	reg_mcdi_lmvlckendrow. end row (<) for lmv lock, default = 2047
15-11	R/W		reserved
10-0	R/W	0	reg_mcdi_lmvlckstartrow. start row (>=) for lmv lock, default = 0

Table 9-794 MCDI\_LMV\_LOCK\_RT\_MODE 0x2f4c

Bit(s)	R/W	Default	Description
31-27	R/W		reserved
26-24	R/W	2	reg_mcdi_lmvlckextmode. extend lines for lmv lock check, check how many lines for lmv locking, default = 2
23-16	R/W	32	reg_mcdi_lmvlckfltcntrt. ratio of flt cnt for lock check, normalized 256 as '1', 255 is set to 256, default = 32
15-8	R/W	48	reg_mcdi_lmvlcklmcntrt1. ratio when use non-zero lmv for lock check, normalized 256 as '1', 255 is set to 256, default = 48
7-0	R/W	106	reg_mcdi_lmvlcklmcntrt0. ratio when use max lmv for lock check, normalized 256 as '1', 255 is set to 256, default = 106

Table 9-795 MCDI\_GMV\_LOCK\_CNT\_THD\_GAIN 0x2f4d

Bit(s)	R/W	Default	Description
31-20	R/W		reserved
19-16	R/W	6	reg_mcdi_gmvlockcntmax. max gmv lock count number, default = 6
15-12	R/W	0	reg_mcdi_gmvlockcntoffst. offset for gmv lock count, -8~7, default = 0
11-8	R/W	8	reg_mcdi_gmvlockcntgain. gain for gmv lock count, normalized 8 as '1', 15 is set to 16, default = 8
7-5	R/W		reserved
4-0	R/W	4	reg_mcdi_gmvlockcntthd. gmv count thd (>=) before be locked, 1~31, default = 4

**Table 9-796 MCDI\_GMV\_LOCK\_ABS\_DIF\_THD 0x2f4e**

Bit(s)	R/W	Default	Description
31-27	R/W		reserved
26-24	R/W	3	reg_mcdi_gmvlockdifthd2. gmv dif thd for third part, before locked, default = 3
23	R/W		reserved
22-20	R/W	2	reg_mcdi_gmvlockdifthd1. gmv dif thd for second part, before locked, default = 2
19	R/W		reserved
18-16	R/W	1	reg_mcdi_gmvlockdifthd0. gmv dif thd for first part, before locked, default = 1
15-13	R/W		reserved
12-8	R/W	15	reg_mcdi_gmvlockabsmax. max abs of gmv to be locked, default = 15
7-5	R/W		reserved
4-0	R/W	1	reg_mcdi_gmvlockabsmin. min abs of gmv to be locked, default = 1

**Table 9-797 MCDI\_HIGH\_VERT\_FRQ\_DIF\_THD 0x2f4f**

Bit(s)	R/W	Default	Description
31-0	R/W	103680	reg_mcdi_highvertfrqfldavgdifthd. high_vert_frq field average luma dif thd (>=), $3 * \text{Blk\_Width} * \text{Blk\_Height}$ , set by software, default = 103680

**Table 9-798 MCDI\_HIGH\_VERT\_FRQ\_DIF\_DIF\_THD 0x2f50**

Bit(s)	R/W	Default	Description
31-0	R/W	103680	reg_mcdi_highvertfrqfldavgdifdifthd. high_vert_frq field average luma dif's dif thd (<), $3 * \text{Blk\_Width} * \text{Blk\_Height}$ , set by software, default = 103680

**Table 9-799 MCDI\_HIGH\_VERT\_FRQ\_RT\_GAIN 0x2f51**

Bit(s)	R/W	Default	Description
31-20	R/W		reserved
19-16	R/W	4	reg_mcdi_highvertfrqcntthd. high_vert_frq count thd (>=) before locked, 1~31, default = 4
15-8	R/W	24	reg_mcdi_highvertfrqbadsadrt. ratio for high_vert_frq bad sad count, normalized 256 as '1', 255 is set to 256, default = 24
7-0	R/W	130	reg_mcdi_highvertfrqbadbadwrt. ratio for high_vert_frq badw count, normalized 256 as '1', 255 is set to 256, default = 130

**Table 9-800 MCDI\_MOTION\_PARADOX\_THD 0x2f52**

Bit(s)	R/W	Default	Description
31-29	R/W		reserved
28-24	R/W	4	reg_mcdi_motionparadoxcntthd. motion paradox count thd (>=) before locked, 1~31, default = 4
23-22	R/W		reserved

Bit(s)	R/W	Default	Description
21-16	R/W	32	reg_mcdi_motionparadoxgmvthd. abs gmv thd (<) of motion paradox, 0~32, note that 32 means invalid gmv, be careful, default = 32
15-0	R/W		reserved

Table 9-801 MCDI\_MOTION\_PARADOX\_RT0x2f53

Bit(s)	R/W	Default	Description
31-24	R/W		reserved
23-16	R/W	24	reg_mcdi_motionparadoxbadsadrt. ratio for field bad sad count of motion paradox, normalized 256 as '1', 255 is set to 256, default = 24
15-8	R/W	120	reg_mcdi_motionparadoxbadrelrt. ratio for field bad reliability count of motion paradox, normalized 256 as '1', 255 is set to 256, default = 120
7-0	R/W	218	reg_mcdi_motionparadoxmntnrt. ratio for field motion count of motion paradox, normalized 256 as '1', 255 is set to 256, default = 218

Table 9-802 MCDI\_MOTION\_REF\_THD 0x2f54

Bit(s)	R/W	Default	Description
31-24	R/W		reserved
23-20	R/W	15	reg_mcdi_motionrefoffst. motion ref additive offset, default = 15
19-16	R/W	8	reg_mcdi_motionrefgain. motion ref gain, normalized 8 as '1', default = 8
15-13	R/W		reserved
12-8	R/W	1	reg_mcdi_motionrefrptmvthd. abs thd (>=) of rpt mv (0~31, 32 means invalid) for motion ref, default = 1
7-2	R/W	2	reg_mcdi_motionrefqmvthd. min thd (>=) of abs qmv for motion ref, note that quarter mv's range is -63~63, default = 2
1-0	R/W	1	reg_mcdi_motionreflpfmode. Mv and (8 x repeat flg) 's lpf mode of motion refinement, 0: no lpf, 1: [1 2 1], 2: [1 2 2 1], default = 1

Table 9-803 MCDI\_REL\_COL\_REF\_RT 0x2f55

Bit(s)	R/W	Default	Description
31-8	R/W		reserved
7-0	R/W	135	reg_mcdi_relcolrefrt. ratio for column cofidence level against column number, for refinement, default = 135

Table 9-804 MCDI\_PD22\_CHK\_THD\_RT 0x2f56

Bit(s)	R/W	Default	Description
31-27	R/W		reserved
26-16	R/W	1	reg_mcdi_pd22chkfltcntrt. ratio for flat count of field pulldown 22 check, normalized 2048 as '1', 2047 is set to 2048, default = 1
15-8	R/W	100	reg_mcdi_pd22chkcncntrt. ratio of pulldown 22 check count, normalized 256 as '1', 255 is set to 256, default = 100

Bit(s)	R/W	Default	Description
7-5	R/W		reserved
4-0	R/W	4	reg_mcdi_pd22chkcntthd. thd (>=) for pd22 count before locked, 1~31, default = 4

Table 9-805 MCDI\_CHAR\_DET\_DIF\_THD 0x2f57

Bit(s)	R/W	Default	Description
31-24	R/W		reserved
23-16	R/W	64	reg_mcdi_chardetminmaxdifthd. thd (>=) for dif between min and max value, default = 64
15-8	R/W	17	reg_mcdi_chardetmaxdifthd. thd (<) for dif between max value, default = 17
7-0	R/W	17	reg_mcdi_chardetmindifthd. thd (<) for dif between min value, default = 17

Table 9-806 MCDI\_CHAR\_DET\_CNT\_THD 0x2f58

Bit(s)	R/W	Default	Description
31-21	R/W		reserved
20-16	R/W	18	reg_mcdi_chardettotcntthd. thd (>=) for total count, 0~21, default = 18
15-13	R/W		reserved
12-8	R/W	1	reg_mcdi_chardetmaxcntthd. thd (>=) for max count, 0~21, default = 1
7-5	R/W		reserved
4-0	R/W	1	reg_mcdi_chardetmincntthd. thd (>=) for min count, 0~21, default = 1

Table 9-807 MCDI\_PD\_22\_CHK\_WND0\_X 0x2f59

Bit(s)	R/W	Default	Description
28-16	R/W	719	reg_mcdi_pd22chkwnd0_x1
12-0	R/W	0	reg_mcdi_pd22chkwnd0_x0

Table 9-808 MCDI\_PD\_22\_CHK\_WND0\_Y 0x2f5a

Bit(s)	R/W	Default	Description
28-16	R/W	39	reg_mcdi_pd22chkwnd0_y1
12-0	R/W	0	reg_mcdi_pd22chkwnd0_y0

Table 9-809 MCDI\_PD\_22\_CHK\_WND1\_X 0x2f5b

Bit(s)	R/W	Default	Description
28-16	R/W	719	reg_mcdi_pd22chkwnd1_x1
12-0	R/W	0	reg_mcdi_pd22chkwnd1_x0

**Table 9-810 MCDI\_PD\_22\_CHK\_WND1\_Y 0x2f5c**

Bit(s)	R/W	Default	Description
28-16	R/W	199	reg_mcdi_pd22chkwnd1_y1
12-0	R/W	40	reg_mcdi_pd22chkwnd1_y0

**Table 9-811 MCDI\_PD\_22\_CHK\_FRC\_LMV 0x2f5d**

Bit(s)	R/W	Default	Description
10	R/W	1	reg_mcdi_pd22chklmvchk2
9	R/W	0	reg_mcdi_pd22chklmvchk1
8	R/W	0	reg_mcdi_pd22chklmvchk0
6	R/W	0	reg_mcdi_pd22chkfrcpd2
5	R/W	0	reg_mcdi_pd22chkfrcpd1
4	R/W	0	reg_mcdi_pd22chkfrcpd0
2	R/W	1	reg_mcdi_pd22chkfrcvof2
1	R/W	0	reg_mcdi_pd22chkfrcvof1
0	R/W	0	reg_mcdi_pd22chkfrcvof0

**Table 9-812 MCDI\_PD\_22\_CHK\_FRC\_LMV 0x2f5e**

Bit(s)	R/W	Default	Description
26	R/W	0	reg_mcdi_pd22chkflg2
25	R/W	0	reg_mcdi_pd22chkflg1
24	R/W	0	reg_mcdi_pd22chkflg
23-16	R/W	1	reg_mcdi_pd22chkcnt2
15-8	R/W	0	reg_mcdi_pd22chkcnt1
7-0	R/W	0	reg_mcdi_pd22chkcnt

**Table 9-813 MCDI\_FIELD\_MV 0x2f60**

Bit(s)	R/W	Default	Description
31-24	R/W		reg_mcdi_pd22chkcnt
23-16	R/W		reg_mcdi_fieldgmvcnt
15	R/W		reg_mcdi_pd22chkflg
14	R/W		reg_mcdi_fieldgmvlock
13-8	R/W		reg_mcdi_fieldrptmv. last field rpt mv
7-6	R/W		reserved
5-0	R/W		reg_mcdi_fieldgmv. last field gmv

Table 9-814 MCDI\_FIELD\_HVF\_PRDX\_CNT 0x2f61

Bit(s)	R/W	Default	Description
31-24	R/W		reg_mcdi_motionparadoxcnt.
23-17	R/W		reserved
16	R/W		reg_mcdi_motionparadoxflg.
15-8	R/W		reg_mcdi_highvertfrqcnt.
7-4	R/W		reserved
3-2	R/W		reg_mcdi_highvertfrqphase.
1	R/W		reserved
0	R/W		reg_mcdi_highvertfrqflg.

Table 9-815 MCDI\_FIELD\_LUMA\_AVG\_SUM\_0 0x2f62

Bit(s)	R/W	Default	Description
31-0	R/W		reg_mcdi fld_luma_avg_sum0.

Table 9-816 MCDI\_FIELD\_LUMA\_AVG\_SUM\_1 0x2f63

Bit(s)	R/W	Default	Description
31-0	R/W		reg_mcdi fld_luma_avg_sum1.

Table 9-817 MCDI\_YCBCR\_BLEND\_CTRL 0x2f64

Bit(s)	R/W	Default	Description
31-16	R/W		reserved
15-8	R/W	0	reg_mcdi_ycbcrblendgain. ycbcr blending gain for cbc in ycbcr. default = 0
7-2	R/W		reserved.
1-0	R/W	2	reg_mcdi_ycbcrblendmode. 0:y+cmb(cb,cr), 1:med(r,g,b), 2:max(r,g,b), default = 2

Table 9-818 MCDI\_MC\_CTRL 0x2f70

Bit(s)	R/W	Default	Description
31-20	R/W	0	reserved
19	R/W	0	reg buf1 enable (if1)
18	R/W	0	reg buf2 enable (if2)
17	R/W	0	reg mv invert
16	R/W	0	mcvec force 0
15	R/W	0	buf2 always en
14-12	R/W	0	reg_mcdi_mcvec_offset: 0: disable 1: 1 pixel offset of mcvec 2: 2 pixel offset of mcvec

Bit(s)	R/W	Default	Description
			3: 3 pixel offset of mcvec 4: 4 pixel offset of mcvec
11	R/W	0	reg_di_weave_both_side
10	R/W	0	reg_mcdi_mc_uv_en: mc for uv if needed, else use ma of uv
9-8	R/W	1	reg_mcdi_mcpreflg. flag to use previous field for MC, 0-forward field, 1: previous field,2-use forward & previous. default = 1
7	R/W	1	reg_mcdi_mcrelrefbycolcfden. enable rel refinement by column cofidence in mc blending, default = 1
6-5	R/W	0	reg_mcdi_mclpfen. enable mc pixles/rel lpf, 0:disable, 1: lpf rel, 2: lpf mc pxls, 3: lpf both rel and mc pxls, default = 0
4-2	R/W	0	reg_mcdi_mcdebugmode. enable mc debug mode, 0:disable, 1: split left/right, 2: split top/bottom, 3: debug mv, 4: debug rel, default = 0
1-0	R/W	1	reg_mcdi_mcen. mcdi enable mode, 0:disable, 1: blend with ma, 2: full mc, default = 1

Table 9-819 MCDI\_MC\_LPF\_MSK\_0 0x2f71

Bit(s)	R/W	Default	Description
31-29	R/W		reserved
28	R		blend output ready
27	R		mcvec read input ready
26	R		mtn read input ready, same as bit24
25	R		ei dout ready ( if0 )
24	R		mtn read input ready
23	R		if2 input ready
22	R		if1 input ready
21	R		blend input ready
20-16	R/W	0	reg_mcdi_mclpfmsk02. mc lpf coef. 2 for pixel 0 of current block, normalized 16 as '1', default = 0
15-13	R/W		reserved
12-8	R/W	9	reg_mcdi_mclpfmsk01. mc lpf coef. 1 for pixel 0 of current block, normalized 16 as '1', default = 9
7-5	R/W		reserved
4-0	R/W	7	reg_mcdi_mclpfmsk00. mc lpf coef. 0 for pixel 0 of current block, normalized 16 as '1', default = 7

Table 9-820 MCDI\_MC\_LPF\_MSK\_1 0x2f72

Bit(s)	R/W	Default	Description
31-29	R/W		reserved
28-21	R		debug info



Bit(s)	R/W	Default	Description
20-16	R/W	0	reg_mcdi_mclpfmsk12. mc lpf coef. 2 for pixel 1 of current block, 0~16, normalized 16 as '1', default = 0
15-13	R/W		reserved
12-8	R/W	11	reg_mcdi_mclpfmsk11. mc lpf coef. 1 for pixel 1 of current block, 0~16, normalized 16 as '1', default = 11
7-5	R/W		reserved
4-0	R/W	5	reg_mcdi_mclpfmsk10. mc lpf coef. 0 for pixel 1 of current block, 0~16, normalized 16 as '1', default = 5

Table 9-821 MCDI\_MC\_LPF\_MSK\_2 0x2f73

Bit(s)	R/W	Default	Description
31-29	R/W		reserved
28-21	R		debug info
20-16	R/W	1	reg_mcdi_mclpfmsk22. mc lpf coef. 2 for pixel 2 of current block, 0~16, normalized 16 as '1', default = 1
15-13	R/W		reserved
12-8	R/W	14	reg_mcdi_mclpfmsk21. mc lpf coef. 1 for pixel 2 of current block, 0~16, normalized 16 as '1', default = 14
7-5	R/W		reserved
4-0	R/W	1	reg_mcdi_mclpfmsk20. mc lpf coef. 0 for pixel 2 of current block, 0~16, normalized 16 as '1', default = 1

Table 9-822 MCDI\_MC\_LPF\_MSK\_3 0x2f74

Bit(s)	R/W	Default	Description
31-29	R/W		reserved
28-21	R		debug info
20-16	R/W	5	reg_mcdi_mclpfmsk32. mc lpf coef. 2 for pixel 3 of current block, 0~16, normalized 16 as '1', default = 5
15-13	R/W		reserved
12-8	R/W	11	reg_mcdi_mclpfmsk31. mc lpf coef. 1 for pixel 3 of current block, 0~16, normalized 16 as '1', default = 11
7-5	R/W		reserved
4-0	R/W	0	reg_mcdi_mclpfmsk30. mc lpf coef. 0 for pixel 3 of current block, 0~16, normalized 16 as '1', default = 0

Table 9-823 MCDI\_MC\_LPF\_MSK\_4 0x2f75

Bit(s)	R/W	Default	Description
31-21	R/W		reserved
20-16	R/W	7	reg_mcdi_mclpfmsk42. mc lpf coef. 2 for pixel 4 of current block, 0~16, normalized 16 as '1', default = 7

Bit(s)	R/W	Default	Description
15-13	R/W		reserved
12-8	R/W	9	reg_mcdi_mclpfmsk41. mc lpf coef. 1 for pixel 4 of current block, 0~16, normalized 16 as '1', default = 9
7-5	R/W		reserved
4-0	R/W	0	reg_mcdi_mclpfmsk40. mc lpf coef. 0 for pixel 4 of current block, 0~16, normalized 16 as '1', default = 0

Table 9-824 MCDI\_MC\_REL\_GAIN\_OFFST\_0 0x2f76

Bit(s)	R/W	Default	Description
31-26	R/W		reserved
25	R/W	0	reg_mcdi_mcmotionparadoxflg. flag of motion paradox, initial with 0 and read from software, default = 0
24	R/W	0	reg_mcdi_mchighvertfrqflg. flag of high vert frq, initial with 0 and read from software, default = 0
23-16	R/W	128	reg_mcdi_mcmotionparadoxoffst. offset (r+ offset) for rel (MC blending coef.) refinement if motion paradox detected before MC blending before MC blending, default = 128
15-12	R/W		reserved
11-8	R/W	8	reg_mcdi_mcmotionparadoxgain. gain for rel (MC blending coef.) refinement if motion paradox detected before MC blending, normalized 8 as '1', set 15 to 16, default = 8
7-4	R/W	15	reg_mcdi_mchighvertfrqoffst. minus offset (alpha - offset) for motion (MA blending coef.) refinement if high vertical frequency detected before MA blending, default = 15
3-0	R/W	8	reg_mcdi_mchighvertfrqgain. gain for motion (MA blending coef.) refinement if high vertical frequency detected before MA blending, normalized 8 as '1', set 15 to 16, default = 8

Table 9-825 MCDI\_MC\_REL\_GAIN\_OFFST\_1 0x2f77

Bit(s)	R/W	Default	Description
31-24	R/W	255	reg_mcdi_mcoutofboundrayoffst. offset (rel + offset) for rel (MC blending coef.) refinement if MC pointed out of boundray before MC blending before MC blending, default = 255
23-20	R/W		reserved
19-16	R/W	8	reg_mcdi_mcoutofboundraygain. gain for rel (MC blending coef.) refinement if MC pointed out of boundray before MC blending, normalized 8 as '1', set 15 to 16, default = 8
15-8	R/W	255	reg_mcdi_mcrelrefbycolcfdoffst. offset (rel + offset) for rel (MC blending coef.) refinement if motion paradox detected before MC blending before MC blending, default = 255
7-4	R/W		reserved.
3-0	R/W	8	reg_mcdi_mcrelrefbycolcfdgain. gain for rel (MC blending coef.) refinement if column cofidence failed before MC blending, normalized 8 as '1', set 15 to 16, default = 8

**Table 9-826 MCDI\_MC\_COL\_CFD\_0 0x2f78**

Bit(s)	R/W	Default	Description
31-0	R/W		mcdi_mc_col_cfd_0. column confidence value 0 read from software. initial = 0

**Table 9-827 MCDI\_MC\_COL\_CFD\_1 0x2f79**

Bit(s)	R/W	Default	Description
31-0	R/W		mcdi_mc_col_cfd_1. column confidence value 1 read from software. initial = 0

**Table 9-828 MCDI\_MC\_COL\_CFD\_2 0x2f7a**

Bit(s)	R/W	Default	Description
31-0	R/W		mcdi_mc_col_cfd_2. column confidence value 2 read from software. initial = 0

**Table 9-829 MCDI\_MC\_COL\_CFD\_3 0x2f7b**

Bit(s)	R/W	Default	Description
31-0	R/W		mcdi_mc_col_cfd_3. column confidence value 3 read from software. initial = 0

**Table 9-830 MCDI\_MC\_COL\_CFD\_4 0x2f7c**

Bit(s)	R/W	Default	Description
31-0	R/W		mcdi_mc_col_cfd_4. column confidence value 4 read from software. initial = 0

**Table 9-831 MCDI\_MC\_COL\_CFD\_5 0x2f7d**

Bit(s)	R/W	Default	Description
31-0	R/W		mcdi_mc_col_cfd_4. column confidence value 5 read from software. initial = 0

**Table 9-832 MCDI\_MC\_COL\_CFD\_6 0x2f7e**

Bit(s)	R/W	Default	Description
31-0	R/W		mcdi_mc_col_cfd_4. column confidence value 6 read from software. initial = 0

**Table 9-833 MCDI\_MC\_COL\_CFD\_7 0x2f7f**

Bit(s)	R/W	Default	Description
31-0	R/W		mcdi_mc_col_cfd_4. column confidence value 7 read from software. initial = 0

**Table 9-834 MCDI\_MC\_COL\_CFD\_8 0x2f80**

Bit(s)	R/W	Default	Description
31-0	R/W		mcdi_mc_col_cfd_4. column confidence value 8 read from software. initial = 0

**Table 9-835 MCDI\_MC\_COL\_CFD\_9 0x2f81**

Bit(s)	R/W	Default	Description
31-0	R/W		mcdi_mc_col_cfd_4. column cofidence value 9 read from software. initial = 0

**Table 9-836 MCDI\_MC\_COL\_CFD\_10 0x2f82**

Bit(s)	R/W	Default	Description
31-0	R/W		mcdi_mc_col_cfd_4. column cofidence value 10 read from software. initial = 0

**Table 9-837 MCDI\_MC\_COL\_CFD\_11 0x2f83**

Bit(s)	R/W	Default	Description
31-0	R/W		mcdi_mc_col_cfd_4. column cofidence value 11 read from software. initial = 0

**Table 9-838 MCDI\_MC\_COL\_CFD\_12 0x2f84**

Bit(s)	R/W	Default	Description
31-0	R/W		mcdi_mc_col_cfd_4. column cofidence value 12 read from software. initial = 0

**Table 9-839 MCDI\_MC\_COL\_CFD\_13 0x2f85**

Bit(s)	R/W	Default	Description
31-0	R/W		mcdi_mc_col_cfd_4. column cofidence value 13 read from software. initial = 0

**Table 9-840 MCDI\_MC\_COL\_CFD\_14 0x2f86**

Bit(s)	R/W	Default	Description
31-0	R/W		mcdi_mc_col_cfd_4. column cofidence value 14 read from software. initial = 0

**Table 9-841 MCDI\_MC\_COL\_CFD\_15 0x2f87**

Bit(s)	R/W	Default	Description
31-0	R/W		mcdi_mc_col_cfd_4. column cofidence value 15 read from software. initial = 0

**Table 9-842 MCDI\_MC\_COL\_CFD\_16 0x2f88**

Bit(s)	R/W	Default	Description
31-0	R/W		mcdi_mc_col_cfd_4. column cofidence value 16 read from software. initial = 0

**Table 9-843 MCDI\_MC\_COL\_CFD\_17 0x2f89**

Bit(s)	R/W	Default	Description
31-0	R/W		mcdi_mc_col_cfd_4. column confidence value 17 read from software. initial = 0

**Table 9-844 MCDI\_MC\_COL\_CFD\_18 0x2f8a**

Bit(s)	R/W	Default	Description
31-0	R/W		mcdi_mc_col_cfd_4. column confidence value 18 read from software. initial = 0

**Table 9-845 MCDI\_MC\_COL\_CFD\_19 0x2f8b**

Bit(s)	R/W	Default	Description
31-0	R/W		mcdi_mc_col_cfd_4. column confidence value 19 read from software. initial = 0

**Table 9-846 MCDI\_MC\_COL\_CFD\_20 0x2f8c**

Bit(s)	R/W	Default	Description
31-0	R/W		mcdi_mc_col_cfd_4. column confidence value 20 read from software. initial = 0

**Table 9-847 MCDI\_MC\_COL\_CFD\_21 0x2f8d**

Bit(s)	R/W	Default	Description
31-0	R/W		mcdi_mc_col_cfd_4. column confidence value 21 read from software. initial = 0

**Table 9-848 MCDI\_MC\_COL\_CFD\_22 0x2f8e**

Bit(s)	R/W	Default	Description
31-0	R/W		mcdi_mc_col_cfd_4. column confidence value 22 read from software. initial = 0

**Table 9-849 MCDI\_MC\_COL\_CFD\_23 0x2f8f**

Bit(s)	R/W	Default	Description
31-0	R/W		mcdi_mc_col_cfd_4. column confidence value 23 read from software. initial = 0

**Table 9-850 MCDI\_MC\_COL\_CFD\_24 0x2f90**

Bit(s)	R/W	Default	Description
31-0	R/W		mcdi_mc_col_cfd_4. column confidence value 24 read from software. initial = 0

**Table 9-851 MCDI\_MC\_COL\_CFD\_25 0x2f91**

Bit(s)	R/W	Default	Description
31-0	R/W		mcdi_mc_col_cfd_4. column confidence value 25 read from software. initial = 0

**Table 9-852 MCDI\_RO\_FLD\_LUMA\_AVG\_SUM 0x2fa0**

Bit(s)	R/W	Default	Description
31-0	R		ro_mcdi_fldlumaavgsum. block's luma avg sum of current filed (block based). initial = 0

**Table 9-853 MCDI\_RO\_GMV\_VLD\_CNT 0x2fa1**

Bit(s)	R/W	Default	Description
31-0	R		ro_mcdi_gmvvldcnt. valid gmv's count of pre one filed (block based). initial = 0

**Table 9-854 MCDI\_RO\_RPT\_FLG\_CNT 0x2fa2**

Bit(s)	R/W	Default	Description
31-0	R		ro_mcdi_rptflgcnt. repeat mv's count of pre one filed (block based). initial = 0

**Table 9-855 MCDI\_RO\_FLD\_BAD\_SAD\_CNT 0x2fa3**

Bit(s)	R/W	Default	Description
31-0	R		ro_mcdi_fldbadsadcnt. bad sad count of whole pre one field (block based). initial = 0

**Table 9-856 MCDI\_RO\_FLD\_BAD\_BADW\_CNT 0x2fa4**

Bit(s)	R/W	Default	Description
31-0	R		ro_mcdi_fldbabadwcnt. bad badw count of whole pre one field (block based). initial = 0

**Table 9-857 MCDI\_RO\_FLD\_BAD\_REL\_CNT 0x2fa5**

Bit(s)	R/W	Default	Description
31-0	R		ro_mcdi_fldbarelcnt. bad rel count of whole pre one field (block based). initial = 0

**Table 9-858 MCDI\_RO\_FLD\_MTN\_CNT 0x2fa6**

Bit(s)	R/W	Default	Description
31-0	R		ro_mcdi_fldmtncnt. motion count of whole pre one field (pixel based). initial = 0

**Table 9-859 MCDI\_RO\_FLD\_VLD\_CNT 0x2fa7**

Bit(s)	R/W	Default	Description
31-0	R		ro_mcdi_fldvldcnt. valid motion count of whole pre one field (pixel based). initial = 0

**Table 9-860 MCDI\_RO\_FLD\_PD\_22\_PRE\_CNT 0x2fa8**

Bit(s)	R/W	Default	Description
31-0	R		ro_mcdi_fldpd22precnt. previous pd22 check count of whole pre one field (block based). initial = 0

**Table 9-861 MCDI\_RO\_FLD\_PD\_22\_FOR\_CNT 0x2fa9**

Bit(s)	R/W	Default	Description
31-0	R		ro_mcdi_fldpd22forcnt. forward pd22 check count of whole pre one field (block based). initial = 0

**Table 9-862 MCDI\_RO\_FLD\_PD\_22\_FLT\_CNT 0x2faa**

Bit(s)	R/W	Default	Description
31-0	R		ro_mcdi_fldpd22fltcnt. flat count (for pd22 check) of whole pre one field (block based). initial = 0

**Table 9-863 MCDI\_RO\_HIGH\_VERT\_FRQ\_FLG 0x2fab**

Bit(s)	R/W	Default	Description
31-16	R		reserved.
15-8	R		ro_mcdi_highvertfrqcnt. high vertical frequency count till previous one field. initial = 0
7-3	R		reserved.
2-1	R		ro_mcdi_highvertfrqphase. high vertical frequency phase of previous one field. initial = 2
0	R		ro_mcdi_highvertfrqflg. high vertical frequency flag of previous one field. initial = 0

**Table 9-864 MCDI\_RO\_GMV\_LOCK\_FLG 0x2fac**

Bit(s)	R/W	Default	Description
31-16	R		reserved.
15-8	R		ro_mcdi_gmvlockcnt. global mv lock count till previous one field. initial = 0
7-2	R		ro_mcdi_gmv. global mv of previous one field. -31~31, initial = 32 (invalid value)
1	R		ro_mcdi_zerogmvlockflg. zero global mv lock flag of previous one field. initial = 0
0	R		ro_mcdi_gmvlockflg. global mv lock flag of previous one field. initial = 0

**Table 9-865 MCDI\_RO\_RPT\_MV 0x2fad**

Bit(s)	R/W	Default	Description
5-0	R		ro_mcdi_rptmv. repeat mv of previous one field. -31~31, initial = 32 (invalid value)

**Table 9-866 MCDI\_RO\_MOTION\_PARADOX\_FLG 0x2fae**

Bit(s)	R/W	Default	Description
31-16	R		reserved.
15-8	R		ro_mcdi_motionparadoxcnt. motion paradox count till prevoius one field. initial = 0
7-1	R		reserved.
0	R		ro_mcdi_motionparadoxflg. motion paradox flag of prevoius one field. initial = 0

**Table 9-867 MCDI\_RO\_PD\_22\_FLG 0x2faf**

Bit(s)	R/W	Default	Description
31-16	R		reserved.
26	R	0	ro_mcdi_pd22flg2. pull down 22 flag of prevoius one field. initial = 0
25	R	0	ro_mcdi_pd22flg1. pull down 22 flag of prevoius one field. initial = 0
24	R	0	ro_mcdi_pd22flg0. pull down 22 flag of prevoius one field. initial = 0
23-16	R	0	ro_mcdi_pd22cnt2. pull down 22 count till prevoius one field. initial = 0
15-8	R	0	ro_mcdi_pd22cnt1. pull down 22 count till prevoius one field. initial = 0
7-0	R	0	ro_mcdi_pd22cnt0. pull down 22 count till prevoius one field. initial = 0

**Table 9-868 MCDI\_RO\_COL\_CFD\_0 0x2fb0**

Bit(s)	R/W	Default	Description
31-0	R		ro_mcdi_col_cfd_0. column cofidence value 0. initial = 0

**Table 9-869 MCDI\_RO\_COL\_CFD\_1 0x2fb1**

Bit(s)	R/W	Default	Description
31-0	R		ro_mcdi_col_cfd_1. column cofidence value 1. initial = 0

**Table 9-870 MCDI\_RO\_COL\_CFD\_2 0x2fb2**

Bit(s)	R/W	Default	Description
31-0	R		ro_mcdi_col_cfd_2. column cofidence value 2. initial = 0

**Table 9-871 MCDI\_RO\_COL\_CFD\_3 0x2fb3**

Bit(s)	R/W	Default	Description
31-0	R		ro_mcdi_col_cfd_3. column cofidence value 3. initial = 0



**Table 9-872 MCDI\_RO\_COL\_CFD\_4 0x2fb4**

Bit(s)	R/W	Default	Description
31-0	R		ro_mcdi_col_cfd_4. column cofidence value 4. initial = 0

**Table 9-873 MCDI\_RO\_COL\_CFD\_5 0x2fb5**

Bit(s)	R/W	Default	Description
31-0	R		ro_mcdi_col_cfd_5. column cofidence value 5. initial = 0

**Table 9-874 MCDI\_RO\_COL\_CFD\_6 0x2fb6**

Bit(s)	R/W	Default	Description
31-0	R		ro_mcdi_col_cfd_6. column cofidence value 6. initial = 0

**Table 9-875 MCDI\_RO\_COL\_CFD\_7 0x2fb7**

Bit(s)	R/W	Default	Description
31-0	R		ro_mcdi_col_cfd_7. column cofidence value 7. initial = 0

**Table 9-876 MCDI\_RO\_COL\_CFD\_8 0x2fb8**

Bit(s)	R/W	Default	Description
31-0	R		ro_mcdi_col_cfd_8. column cofidence value 8. initial = 0

**Table 9-877 MCDI\_RO\_COL\_CFD\_9 0x2fb9**

Bit(s)	R/W	Default	Description
31-0	R		ro_mcdi_col_cfd_9. column cofidence value 9. initial = 0

**Table 9-878 MCDI\_RO\_COL\_CFD\_10 0x2fba**

Bit(s)	R/W	Default	Description
31-0	R		ro_mcdi_col_cfd_10. column cofidence value 10. initial = 0

**Table 9-879 MCDI\_RO\_COL\_CFD\_11 0x2fbb**

Bit(s)	R/W	Default	Description
31-0	R		ro_mcdi_col_cfd_11. column cofidence value 11. initial = 0

**Table 9-880 MCDI\_RO\_COL\_CFD\_12 0x2fbc**

Bit(s)	R/W	Default	Description
31-0	R		ro_mcdi_col_cfd_12. column cofidence value 12. initial = 0

**Table 9-881 MCDI\_RO\_COL\_CFD\_13 0x2fbd**

Bit(s)	R/W	Default	Description
31-0	R		ro_mcdi_col_cfd_13. column cofidence value 13. initial = 0

**Table 9-882 MCDI\_RO\_COL\_CFD\_14 0x2fbe**

Bit(s)	R/W	Default	Description
31-0	R		ro_mcdi_col_cfd_14. column cofidence value 14. initial = 0

**Table 9-883 MCDI\_RO\_COL\_CFD\_15 0x2fbf**

Bit(s)	R/W	Default	Description
31-0	R		ro_mcdi_col_cfd_15. column cofidence value 15. initial = 0

**Table 9-884 MCDI\_RO\_COL\_CFD\_16 0x2fc0**

Bit(s)	R/W	Default	Description
31-0	R		ro_mcdi_col_cfd_16. column cofidence value 16. initial = 0

**Table 9-885 MCDI\_RO\_COL\_CFD\_17 0x2fc1**

Bit(s)	R/W	Default	Description
31-0	R		ro_mcdi_col_cfd_17. column cofidence value 17. initial = 0

**Table 9-886 MCDI\_RO\_COL\_CFD\_18 0x2fc2**

Bit(s)	R/W	Default	Description
31-0	R		ro_mcdi_col_cfd_18. column cofidence value 18. initial = 0

**Table 9-887 MCDI\_RO\_COL\_CFD\_19 0x2fc3**

Bit(s)	R/W	Default	Description
31-0	R		ro_mcdi_col_cfd_19. column cofidence value 19. initial = 0

**Table 9-888 MCDI\_RO\_COL\_CFD\_20 0x2fc4**

Bit(s)	R/W	Default	Description
31-0	R		ro_mcdi_col_cfd_20. column cofidence value 20. initial = 0

**Table 9-889 MCDI\_RO\_COL\_CFD\_21 0x2fc5**

Bit(s)	R/W	Default	Description
31-0	R		ro_mcdi_col_cfd_21. column cofidence value 21. initial = 0

**Table 9-890 MCDI\_RO\_COL\_CFD\_22 0x2fc6**

Bit(s)	R/W	Default	Description
31-0	R		ro_mcdi_col_cfd_22. column cofidence value 22. initial = 0

**Table 9-891 MCDI\_RO\_COL\_CFD\_23 0x2fc7**

Bit(s)	R/W	Default	Description
31-0	R		ro_mcdi_col_cfd_23. column cofidence value 23. initial = 0

**Table 9-892 MCDI\_RO\_COL\_CFD\_24 0x2fc8**

Bit(s)	R/W	Default	Description
31-0	R		ro_mcdi_col_cfd_24. column cofidence value 24. initial = 0

**Table 9-893 MCDI\_RO\_COL\_CFD\_25 0x2fc9**

Bit(s)	R/W	Default	Description
31-0	R		ro_mcdi_col_cfd_25. column cofidence value 25. initial = 0

**Table 9-894 MCDI\_RO\_FLD\_PD\_22\_PRE\_CNT1 0x2fca**

Bit(s)	R/W	Default	Description
31-0	R		previous pd22 check count of whole pre one field(block based). initial = 0

**Table 9-895 MCDI\_RO\_FLD\_PD\_22\_POR\_CNT1 0x2fcb**

Bit(s)	R/W	Default	Description
31-0	R		forward pd22 check count of whole pre one field(block based). initial = 0

**Table 9-896 MCDI\_RO\_FLD\_PD\_22\_FLT\_CNT1 0x2fcc**

Bit(s)	R/W	Default	Description
31-0	R		flat count(for pd22 check) of whole pre one field(block based). initial = 0

**Table 9-897 MCDI\_RO\_FLD\_PD\_22\_PRE\_CNT2 0x2fcd**

Bit(s)	R/W	Default	Description
31-0	R		previous pd22 check count of whole pre one field(block based). initial = 0

**Table 9-898 MCDI\_RO\_FLD\_PD\_22\_POR\_CNT2 0x2fce**

Bit(s)	R/W	Default	Description
31-0	R		forward pd22 check count of whole pre one field(block based). initial = 0

**Table 9-899 MCDI\_RO\_FLD\_PD\_22\_FLT\_CNT2 0x2fcf**

Bit(s)	R/W	Default	Description
31-0	R		flat count(for pd22 check) of whole pre one field(block based). initial = 0

### 9.2.3.13 PULLDOWN

**Table 9-900 DIPD\_COMB\_CTRL0 0x2fd0**

Bit(s)	R/W	Default	Description
31-24	W		Cmb_v_dif_min
23-16	W		Cmb_v_dif_max
15-8	W		Cmb_crg_min
7-0	W		Cmb_crg_max

**Table 9-901 DIPD\_COMB\_CTRL1 0x2fd1**

Bit(s)	R/W	Default	Description
31	W		Pd_check_en
29-24	W		Cmb_wv_min3
21-16	W		Cmb_wv_min2
13-8	W		Cmb_wv_min1
5-0	W		Cmb_wv_min0

**Table 9-902 DIPD\_COMB\_CTRL2 0x2fd2**

Bit(s)	R/W	Default	Description
31-28	W		Cmb_wnd_cnt1
25-20	W		Ccnt_cmmin1
19-16	W		Ccnt_mtmin
13-8	W		Ccnt_cmmin
5-0	W		Cmb_wv_min4

Table 9-903 DIPD\_COMB\_CTRL3 0x2fd3

Bit(s)	R/W	Default	Description
31	W		Cmb32spcl
17-12	W		Cmb_wnd_mthd
11-4	W		Cmb_abs_nocmb
3-0	W		Cnt_minlen

Table 9-904 DIPD\_COMB\_CTRL4 0x2fd4

Bit(s)	R/W	Default	Description
30	W		Flm_stamtn_en
29-28	W		In_horflt
27-20	W		Alpha
19-16	W		Rhtran_ctmtd
15-8	W		Htran_mnth1
7-0	W		Htran_mnth0

Table 9-905 DIPD\_COMB\_CTRL5 0x2fd5

Bit(s)	R/W	Default	Description
31-24	W		Fld_mindif
23-16	W		Frm_mindif
13-8	W		Flm_smp_mtn_cnt
7-0	W		Flm_smp_mtn_thd

Table 9-906 DIPD\_RO\_COMB\_0 0x2fd6

Bit(s)	R/W	Default	Description
31-0	R		frmdif

Table 9-907 DIPD\_RO\_COMB\_1 0x2fd7

Bit(s)	R/W	Default	Description
31-0	R		Frmdif0

Table 9-908 DIPD\_RO\_COMB\_2 0x2fd8

Bit(s)	R/W	Default	Description
31-0	R		Frmdif1

**Table 9-909 DIPD\_RO\_COMB\_3 0x2fd9**

Bit(s)	R/W	Default	Description
31-0	R		Frmdif2

**Table 9-910 DIPD\_RO\_COMB\_4 0x2fda**

Bit(s)	R/W	Default	Description
31-0	R		Frmdif3

**Table 9-911 DIPD\_RO\_COMB\_5 0x2fdb**

Bit(s)	R/W	Default	Description
31-0	R		Frmdif4

**Table 9-912 DIPD\_RO\_COMB\_6 0x2fdc**

Bit(s)	R/W	Default	Description
31-0	R		flddif

**Table 9-913 DIPD\_RO\_COMB\_7 0x2fdd**

Bit(s)	R/W	Default	Description
31-0	R		Flddif0

**Table 9-914 DIPD\_RO\_COMB\_8 0x2fde**

Bit(s)	R/W	Default	Description
31-0	R		Flddif1

**Table 9-915 DIPD\_RO\_COMB\_9 0x2fdf**

Bit(s)	R/W	Default	Description
31-0	R		Flddif2

**Table 9-916 DIPD\_RO\_COMB\_10 0x2fe0**

Bit(s)	R/W	Default	Description
31-0	R		Flddif3

**Table 9-917 DIPD\_RO\_COMB\_11 0x2fe1**

Bit(s)	R/W	Default	Description
31-0	R		Flddif4

**Table 9-918 DIPD\_RO\_COMB\_12 0x2fe2**

Bit(s)	R/W	Default	Description
31-0	R		Ro_rt0

**Table 9-919 DIPD\_RO\_COMB\_13 0x2fe3**

Bit(s)	R/W	Default	Description
31-0	R		Ro_rt1

**Table 9-920 DIPD\_RO\_COMB\_14 0x2fe4**

Bit(s)	R/W	Default	Description
31-0	R		Ro_rt2

**Table 9-921 DIPD\_RO\_COMB\_15 0x2fe5**

Bit(s)	R/W	Default	Description
31-0	R		Ro_rt3

**Table 9-922 DIPD\_RO\_COMB\_16 0x2fe6**

Bit(s)	R/W	Default	Description
31-0	R		Ro_rt4

**Table 9-923 DIPD\_RO\_COMB\_17 0x2fe7**

Bit(s)	R/W	Default	Description
31-0	R		Ro_rt5

**Table 9-924 DIPD\_RO\_COMB\_18 0x2fe8**

Bit(s)	R/W	Default	Description
31-0	R		Ro_rt6

**Table 9-925 DIPD\_RO\_COMB\_19 0x2fe9**

Bit(s)	R/W	Default	Description
31-0	R		Ro_rt7

**Table 9-926 DIPD\_RO\_COMB\_20 0x2fea**

Bit(s)	R/W	Default	Description
31-0	R		Ro_rt8

Table 9-927 DIPD\_COMB\_CTRL5 0x2fd5

Bit(s)	R/W	Default	Description
31-24	W		Fld_mindif
23-16	W		Frm_mindif
13-8	W		Flm_smp_mtn_cnt
7-0	W		Flm_smp_mtn_thd

Table 9-928 DIPD\_COMB\_CTRL6 0x2feb

Bit(s)	R/W	Default	Description
21	Rw	0	Reg_edit_sel
20	Rw	1	Reg_horfft_en
16-12	Rw	7	Reg_combseglen
9-4	Rw	6	Reg_trancombrat
3-0	Rw	4	Reg_combsegmin

### 9.2.3.14 DNR Registers

Table 9-929 DNR\_CTRL 0x2d00

Bit(s)	R/W	Default	Description
31:17	R/W		reserved
16	R/W		reg_dnr_en
15	R/W		reg_dnr_db_vdbstep , vdb step, 0: 4, 1: 8 . unsigned , default = 1
14	R/W		reg_dnr_db_vdbprten, vdb protectoin enable. unsigned , default = 1
13	R/W		reg_dnr_gbs_difen , enable dif (between LR and LL/RR) condition for gbs stat.. unsigned , default = 0
12	R/W		reg_dnr_luma_en , enable ybcr2luma module . unsigned , default = 1
11:10	R/W		reg_dnr_db_mod, deblocking mode, 0: disable, 1: horizontal deblocking, 2: vertical deblocking, 3: horizontal & vertical deblocking. unsigned , default = 3
9	R/W		reg_dnr_db_chrmn , enable chroma deblocking . unsigned , default = 1
8	R/W		reg_dnr_hvdif_mod , 0: calc. difs by original Y, 1: by new luma. unsigned , default = 1
7	R/W		reserved
6: 4	R/W		reg_dnr_demo_lften , b0: Y b1:U b2:V . unsigned , default = 7
3	R/W		reserved
2: 0	R/W		reg_dnr_demo_rgten , b0: Y b1:U b2:V . unsigned , default = 7



**Table 9-930 DNR\_HVSIZE 0x2d01**

Bit(s)	R/W	Default	Description
31:29	R/W		reserved
28:16	R/W		reg_dnr_hsize , hsize . unsigned , default = 0
15:13	R/W		reserved
12: 0	R/W		reg_dnr_vsize , vsize . unsigned , default = 0

**Table 9-931 DNR\_DBLK\_BLANK\_NUM 0x2d02**

Bit(s)	R/W	Default	Description
31:16	R/W		reserved
15: 8	R/W		reg_dblk_hblank_num, deblock hor blank num. unsigned , default = 16
7: 0	R/W		reg_dblk_vblank_num, deblock ver blank num. unsigned , default = 45

**Table 9-932 DNR\_BLK\_OFFST 0x2d03**

Bit(s)	R/W	Default	Description
31: 7	R/W		reserved
6: 4	R/W		reg_dnr_hbofst, horizontal block offset may provide by software calc.. unsigned , default = 0
3	R/W		reserved
2: 0	R/W		reg_dnr_vbofst, vertical block offset may provide by software calc.. unsigned , default = 0

**Table 9-933 DNR\_GBS 0x2d04**

Bit(s)	R/W	Default	Description
31: 2	R/W		reserved
1: 0	R/W		reg_dnr_gbs , global block strength may update by software calc.. unsigned , default = 0

**Table 9-934 DNR\_HBOFFST\_STAT 0x2d05**

Bit(s)	R/W	Default	Description
31:24	R/W		reg_dnr_hbof_difthd, dif threshold ( $\geq$ ) between LR and LL/RR. unsigned , default = 2
23:16	R/W		reg_dnr_hbof_edgethd , edge threshold ( $\leq$ ) for LR . unsigned , default = 32
15: 8	R/W		reg_dnr_hbof_flatthd , flat threshold ( $\geq$ ) for LR . unsigned , default = 0
7	R/W		reserved
6: 4	R/W		reg_dnr_hbof_delta , delta for weighted bin accumulator. unsigned , default = 1

Bit(s)	R/W	Default	Description
3	R/W		reserved
2: 0	R/W		reg_dnr_hbof_statmod , statistic mode for horizontal block offset, 0: count flags for 8-bin, 1: count LRs for 8-bin, 2: count difs for 8-bin, 3: count weighted flags for 8-bin, 4: count flags for first 32-bin, 5: count LRs for first 32-bin, 6 or 7: count difs for first 32-bin. unsigned , default = 2

Table 9-935 DNR\_VBOFFST\_STAT 0x2d06

Bit(s)	R/W	Default	Description
31:24	R/W		reg_dnr_vbof_difthd , dif threshold ( $\geq$ ) between Up and Dw. unsigned , default = 1
23:16	R/W		reg_dnr_vbof_edgethd , edge threshold ( $\leq$ ) for Up/Dw. unsigned , default = 16
15: 8	R/W		reg_dnr_vbof_flatthd , flat threshold ( $\geq$ ) for Up/Dw. unsigned , default = 0
7	R/W		reserved
6: 4	R/W		reg_dnr_vbof_delta , delta for weighted bin accumulator. unsigned , default = 1
3	R/W		reserved
2: 0	R/W		reg_dnr_vbof_statmod , statistic mode for vertical block offset, 0: count flags for 8-bin, 1: count Ups for 8-bin, 2: count difs for 8-bin, 3: count weighted flags for 8-bin, 4: count flags for first 32-bin, 5: count Ups for first 32-bin, 6 or 7: count difs for first 32-bin. unsigned , default = 2

Table 9-936 DNR\_GBS\_STAT 0x2d07

Bit(s)	R/W	Default	Description
31:24	R/W		reg_dnr_gbs_edgethd , edge threshold ( $\leq$ ) for LR . unsigned , default = 32
23:16	R/W		reg_dnr_gbs_flatthd , flat threshold ( $\geq$ ) for LR . unsigned , default = 0
15: 8	R/W		reg_dnr_gbs_varthd , variation threshold ( $\leq$ ) for Lvar/Rvar. unsigned , default = 16
7: 0	R/W		reg_dnr_gbs_difthd , dif threshold ( $\geq$ ) between LR and LL/RR. unsigned , default = 2

Table 9-937 DNR\_STAT\_X\_START\_END 0x2d08

Bit(s)	R/W	Default	Description
31:30	R/W		reserved
29:16	R/W		reg_dnr_stat_xst . unsigned , default = 24
15:14	R/W		reserved
13: 0	R/W		reg_dnr_stat_xed . unsigned , default = HSIZE - 25

**Table 9-938 DNR\_STAT\_Y\_START\_END 0x2d09**

Bit(s)	R/W	Default	Description
31:30	R/W		reserved
29:16	R/W		reg_dnr_stat_yst . unsigned , default = 24
15:14	R/W		reserved
13: 0	R/W		reg_dnr_stat_yed . unsigned , default = VSIZE - 25

**Table 9-939 DNR\_LUMA 0x2d0a**

Bit(s)	R/W	Default	Description
31:27	R/W		reserved
26:24	R/W		reg_dnr_luma_sqrtshft , left shift for fast squart of chroma, [0, 4]. unsigned , default = 2
23:21	R/W		reserved
20:16	R/W		reg_dnr_luma_sqrtoffst, offset for fast squart of chroma. signed , default = 0
15	R/W		reserved
14:12	R/W		reg_dnr_luma_wcmmod , theta related to warm/cool segment line, 0: 0, 1: 45, 2: 90, 3: 135, 4: 180, 5: 225, 6: 270, 7: 315 . unsigned , default = 3
11: 8	R/W		reg_dnr_luma_cshft , shift for calc. delta part, 0~8, . unsigned , default = 8
7: 6	R/W		reserved
5: 0	R/W		reg_dnr_luma_cgain , final gain for delta part, 32 normalized to "1". unsigned , default = 4

**Table 9-940 DNR\_DB\_YEDGE\_THD 0x2d0b**

Bit(s)	R/W	Default	Description
31:24	R/W		reg_dnr_db_yedgethd0 , edge threshold0 for luma . unsigned , default = 12
23:16	R/W		reg_dnr_db_yedgethd1 , edge threshold1 for luma . unsigned , default = 15
15: 8	R/W		reg_dnr_db_yedgethd2 , edge threshold2 for luma . unsigned , default = 18
7: 0	R/W		reg_dnr_db_yedgethd3 , edge threshold3 for luma . unsigned , default = 25

**Table 9-941 DNR\_DB\_CEDGE\_THD 0x2d0c**

Bit(s)	R/W	Default	Description
31:24	R/W		reg_dnr_db_cedgethd0 , edge threshold0 for chroma . unsigned , default = 12
23:16	R/W		reg_dnr_db_cedgethd1 , edge threshold1 for chroma . unsigned , default = 15
15: 8	R/W		reg_dnr_db_cedgethd2 , edge threshold2 for chroma . unsigned , default = 18
7: 0	R/W		reg_dnr_db_cedgethd3 , edge threshold3 for chroma . unsigned , default = 25

Table 9-942 DNR\_DB\_HGAP 0x2d0d

Bit(s)	R/W	Default	Description
31:24	R/W		reserved
23:16	R/W		reg_dnr_db_hgapthd , horizontal gap thd ( $\leq$ ) for very sure blockiness . unsigned , default = 8
15: 8	R/W		reg_dnr_db_hgapdifthd , dif thd between hgap and lft/rgt hdifs. unsigned , default = 1
7: 1	R/W		reserved
0	R/W		reg_dnr_db_hgapmod , horizontal gap calc. mode, 0: just use current col x, 1: find max between (x-1, x, x+1) . unsigned , default = 0

Table 9-943 DNR\_DB\_HBS 0x2d0e

Bit(s)	R/W	Default	Description
31: 6	R/W		reserved
5: 4	R/W		reg_dnr_db_hbsup , horizontal bs up value . unsigned , default = 1
3: 2	R/W		reg_dnr_db_hbsmax , max value of hbs for global control. unsigned , default = 3
1: 0	R/W		reg_dnr_db_hgbsth , gbs thd ( $\geq$ ) for hbs calc. . unsigned , default = 1

Table 9-944 DNR\_DB\_HACT 0x2d0f

Bit(s)	R/W	Default	Description
31:16	R/W		reserved
15: 8	R/W		reg_dnr_db_hactthd0, thd0 of hact, for block classification. unsigned , default = 10
7: 0	R/W		reg_dnr_db_hactthd1, thd1 of hact, for block classification. unsigned , default = 32

Table 9-945 DNR\_DB\_YHDELTA\_GAIN 0x2d10

Bit(s)	R/W	Default	Description
31:27	R/W		reserved
26:24	R/W		reg_dnr_db_yhdeltagain1, (p1-q1) gain for Y's delta calc. when bs=1, normalized 8 as "1" . unsigned , default = 2
23	R/W		reserved
22:20	R/W		reg_dnr_db_yhdeltagain2, (p1-q1) gain for Y's delta calc. when bs=2, normalized 8 as "1" . unsigned , default = 0
19	R/W		reserved
18:16	R/W		reg_dnr_db_yhdeltagain3, (p1-q1) gain for Y's delta calc. when bs=3, normalized 8 as "1" . unsigned , default = 0
15	R/W		reserved
14: 8	R/W		reg_dnr_db_yhdeltaadjoffst, offset for adjust Y's hdelta (-64, 63). signed , default = 0

Bit(s)	R/W	Default	Description
7: 6	R/W		reserved
5: 0	R/W		reg_dnr_db_yhdeltaadjgain , gain for adjust Y's hdelta, normalized 32 as "1" . unsigned , default = 32

Table 9-946 DNR\_DB\_YHDELTA2\_GAIN 0x2d11

Bit(s)	R/W	Default	Description
31:30	R/W		reserved
29:24	R/W		reg_dnr_db_yhdelta2gain2, gain for bs=2's adjust Y's hdelta2, normalized 64 as "1" . unsigned , default = 8
23:21	R/W		reserved
20:16	R/W		reg_dnr_db_yhdelta2offst2 , offset for bs=2's adjust Y's hdelta2 (-16, 15). signed , default = 0
15:14	R/W		reserved
13: 8	R/W		reg_dnr_db_yhdelta2gain3, gain for bs=3's adjust Y's hdelta2, normalized 64 as "1" . unsigned , default = 4
7: 5	R/W		reserved
4: 0	R/W		reg_dnr_db_yhdelta2offst3 , offset for bs=3's adjust Y's hdelta2 (-16, 15). signed , default = 0

Table 9-947 DNR\_DB\_CHDELTA\_GAIN 0x2d12

Bit(s)	R/W	Default	Description
31:27	R/W		reserved
26:24	R/W		reg_dnr_db_chdeltagain1, (p1-q1) gain for UV's delta calc. when bs=1, normalized 8 as "1". unsigned , default = 2
23	R/W		reserved
22:20	R/W		reg_dnr_db_chdeltagain2, (p1-q1) gain for UV's delta calc. when bs=2, normalized 8 as "1". unsigned , default = 0
19	R/W		reserved
18:16	R/W		reg_dnr_db_chdeltagain3, (p1-q1) gain for UV's delta calc. when bs=3, normalized 8 as "1". unsigned , default = 0
15	R/W		reserved
14: 8	R/W		reg_dnr_db_chdeltaadjoffst, offset for adjust UV's hdelta (-64, 63). signed , default = 0
7: 6	R/W		reserved
5: 0	R/W		reg_dnr_db_chdeltaadjgain , gain for adjust UV's hdelta, normalized 32 as "1". unsigned , default = 32

Table 9-948 DNR\_DB\_CHDELTA2\_GAIN 0x2d13

Bit(s)	R/W	Default	Description
31:30	R/W		reserved
29:24	R/W		reg_dnr_db_chdelta2gain2, gain for bs=2's adjust UV's hdelta2, normalized 64 as "1". unsigned, default = 8
23:21	R/W		reserved
20:16	R/W		reg_dnr_db_chdelta2offst2, offset for bs=2's adjust UV's hdelta2 (-16, 15). signed, default = 0
15:14	R/W		reserved
13: 8	R/W		reg_dnr_db_chdelta2gain3, gain for bs=2's adjust UV's hdelta2, normalized 64 as "1". unsigned, default = 4
7: 5	R/W		reserved
4: 0	R/W		reg_dnr_db_chdelta2offst3, offset for bs=2's adjust UV's hdelta2 (-16, 15). signed, default = 0

Table 9-949 DNR\_DB\_YC\_VEDGE\_THD 0x2d14

Bit(s)	R/W	Default	Description
31:16	R/W		reserved
15: 8	R/W		reg_dnr_db_yvedgethd, special Y's edge thd for vdb. unsigned, default = 12
7: 0	R/W		reg_dnr_db_cvedgethd, special UV's edge thd for vdb. unsigned, default = 12

Table 9-950 DNR\_DB\_VBS\_MISC 0x2d15

Bit(s)	R/W	Default	Description
31:24	R/W		reg_dnr_db_vgapthd, vertical gap thd (<=) for very sure blockiness. unsigned, default = 8
23:16	R/W		reg_dnr_db_vactthd, thd of vact, for block classification. unsigned, default = 10
15: 8	R/W		reg_dnr_db_vgapdifthd, dif thd between vgap and vact. unsigned, default = 4
7: 4	R/W		reserved
3: 2	R/W		reg_dnr_db_vbsmax, max value of vbs for global control. unsigned, default = 2
1: 0	R/W		reg_dnr_db_vgbsthhd, gbs thd (>=) for vbs calc. unsigned, default = 1

Table 9-951 DNR\_DB\_YVDELTA\_GAIN 0x2d16

Bit(s)	R/W	Default	Description
31:30	R/W		reserved
29:24	R/W		reg_dnr_db_yvdeltaadjgain, gain for adjust Y's vdelta, normalized 32 as "1". unsigned, default = 32
23	R/W		reserved
22:16	R/W		reg_dnr_db_yvdeltaadjoffst, offset for adjust Y's vdelta (-64, 63). signed, default = 0

Bit(s)	R/W	Default	Description
15:14	R/W		reserved
13: 8	R/W		reg_dnr_db_yvdelta2gain, gain for adjust Y's vdelta2, normalized 64 as "1". unsigned , default = 8
7: 5	R/W		reserved
4: 0	R/W		reg_dnr_db_yvdelta2offst, offset for adjust Y's vdelta2 (-16, 15). signed , default = 0

Table 9-952 DNR\_DB\_CVDELTA\_GAIN0x2d17

Bit(s)	R/W	Default	Description
31:30	R/W		reserved
29:24	R/W		reg_dnr_db_cvdeltaadjgain , gain for adjust UV's vdelta, normalized 32 as "1". unsigned , default = 32
23	R/W		reserved
22:16	R/W		reg_dnr_db_cvdeltaadjoffst, offset for adjust UV's vdelta (-64, 63). signed , default = 0
15:14	R/W		reserved
13: 8	R/W		reg_dnr_db_cvdelta2gain, gain for adjust UV's vdelta2, normalized 64 as "1". unsigned , default = 8
7: 5	R/W		reserved
4: 0	R/W		reg_dnr_db_cvdelta2offst, offset for adjust UV's vdelta2 (-16, 15). signed , default = 0

Table 9-953 DNR\_RO\_GBS\_STAT\_LR 0x2d18

Bit(s)	R/W	Default	Description
31: 0	R		ro_gbs_stat_lr. unsigned , default = 0

Table 9-954 DNR\_RO\_GBS\_STAT\_LL 0x2d19

Bit(s)	R/W	Default	Description
31: 0	R		ro_gbs_stat_ll. unsigned , default = 0

Table 9-955 DNR\_RO\_GBS\_STAT\_RR 0x2d1a

Bit(s)	R/W	Default	Description
31: 0	R		ro_gbs_stat_rr. unsigned , default = 0

Table 9-956 DNR\_RO\_GBS\_STAT\_DIF 0x2d1b

Bit(s)	R/W	Default	Description
31: 0	R		ro_gbs_stat_dif. unsigned , default = 0

**Table 9-957 DNR\_RO\_GBS\_STAT\_CNT 0x2d1c**

Bit(s)	R/W	Default	Description
31: 0	R		ro_gbs_stat_cnt . unsigned , default = 0

**Table 9-958 DNR\_RO\_HBOF\_STAT\_CNT\_0 0x2d1d**

Bit(s)	R/W	Default	Description
31: 0	R		ro_hbof_stat_cnt0 . unsigned , default = 0

**Table 9-959 DNR\_RO\_HBOF\_STAT\_CNT\_31 0x2d3c**

Bit(s)	R/W	Default	Description
31: 0	R		ro_hbof_stat_cnt31 . unsigned , default = 0

**Table 9-960 DNR\_RO\_VBOF\_STAT\_CNT\_0 0x2d3d**

Bit(s)	R/W	Default	Description
31: 0	R		ro_vbof_stat_cnt0 . unsigned , default = 0

**Table 9-961 DNR\_RO\_VBOF\_STAT\_CNT\_31 0x2d5c**

Bit(s)	R/W	Default	Description
31: 0	R		ro_vbof_stat_cnt31 . unsigned , default = 0

**Table 9-962 DNR\_DM\_CTRL 0x2d60**

Bit(s)	R/W	Default	Description
31:13	R/W		reserved
12	R/W	1	reg_dnr_fedgeflg_en , 1 to enable edge flag calculation for each frame
11	R/W	1	reg_dnr_fedgeflg_cl , 1 to clear the edge flag to 0 for each frame
10	R/W	0	reg_dnr_fedgeflg_df , user defined edge flag when reg_dnr_fedgeflg_en = 0
9	R/W	0	reg_dnr_dm_en , 1 to enable de-mosquito unit
8	R/W	1	reg_dnr_dm_chrmn , 1 to enable chrome processing for de-mosquito
7: 6	R/W	3	reg_dnr_dm_level , de-mosquito level
5: 4	R/W	1	reg_dnr_dm_leveldw0 , level down when gbs is small
3: 2	R/W	1	reg_dnr_dm_leveldw1 , level down for flat blocks
1: 0	R/W	0	reg_dnr_dm_gbsthld , small/large threshold for gbs



Table 9-963 DNR\_DM\_NR\_BLND 0x2d61

Bit(s)	R/W	Default	Description
31:25	R/W		reserved
24	R/W	0	reg_dnr_dm_defalpen , 1 to enable user defined alpha for DM/NR blend
23:16	R/W	0	reg_dnr_dm_defalp , user defined alpha for DM/NR blend
15:14	R/W		reserved
13: 8	R/W	32	reg_dnr_dm_alpgain , gain for DM/NR alpha, normalized 32 as 1
7: 0	R/W	0	reg_dnr_dm_alpoffset , offset for DM/NR alpha

Table 9-964 DNR\_DM\_RNG\_THD 0x2d62

Bit(s)	R/W	Default	Description
31:24	R/W		reserved
23:16	R/W	2	reg_dnr_dm_rgnminthd
15: 8	R/W	64	reg_dnr_dm_rgnmaxthd
7: 0	R/W	4	reg_dnr_dm_rgndifthd

Table 9-965 DNR\_DM\_RNG\_GAIN\_OFST 0x2d63

Bit(s)	R/W	Default	Description
31:14	R/W		reserved
13: 8	R/W	16	reg_dnr_dm_rnggain , normalized 16 as 1
7:6	R/W		reserved
5: 0	R/W	0	reg_dnr_dm_rgnofst

Table 9-966 DNR\_DM\_DIR\_MISC 0x2d64

Bit(s)	R/W	Default	Description
31:30	R/W		reserved
28:24	R/W	0	reg_dnr_dm_diralpgain
23:22	R/W		reserved
21:16	R/W	0	reg_dnr_dm_diralpofst
15:13	R/W		reserved
12: 8	R/W	0	reg_dnr_dm_diralpmin

**Table 9-967 DNR\_DM\_COR\_DIF 0x2d65**

Bit(s)	R/W	Default	Description
31:4	R/W		reserved
3:1	R/W	3	reg_dnr_dm_cordifshft
0	R/W	1	reg_dnr_dm_cordifmod , 0: use max dir dif as cordif, 1: use max3x3-min3x3 as cordif

**Table 9-968 DNR\_DM\_FLT\_THD 0x2d66**

Bit(s)	R/W	Default	Description
31:24	R/W	4	reg_dnr_dm_flthd00 , block flat threshold0 for block average difference when gbs is small
23:16	R/W	6	reg_dnr_dm_flthd01 , block flat threshold1 for block average difference when gbs is small
15: 8	R/W	9	reg_dnr_dm_flthd10 , block flat threshold0 for block average difference when gbs is larger

**Table 9-969 DNR\_DM\_VAR\_THD 0x2d67**

Bit(s)	R/W	Default	Description
31:24	R/W	2	reg_dnr_dm_varthd00 , block variance threshold0 (>=) when gbs is small
23:16	R/W	15	reg_dnr_dm_varthd01 , block variance threshold1 (<=) when gbs is small
15: 8	R/W	3	reg_dnr_dm_varthd10 , block variance threshold0 (>=) when gbs is larger

**Table 9-970 DNR\_DM\_EDGE\_DIF\_THD 0x2d68**

Bit(s)	R/W	Default	Description
31:24	R/W	32	reg_dnr_dm_edgethd0 , block edge threshold (<=) when gbs is small
23:16	R/W	48	reg_dnr_dm_edgethd1 , block edge threshold (<=) when gbs is larger
15: 8	R/W	48	reg_dnr_dm_difhd0 , block dif threshold (<=) when gbs is small

**Table 9-971 DNR\_DM\_AVG\_THD 0x2d69**

Bit(s)	R/W	Default	Description
31:16	R/W		reserved
15: 8	R/W	160	reg_dnr_dm_avgthd0, block average threshold (>=) when gbs is small

**Table 9-972 DNR\_DM\_AVG\_VAR\_DIF\_THD 0x2d6a**

Bit(s)	R/W	Default	Description
31:16	R/W		reserved
15: 8	R/W	12	reg_dnr_dm_avgdifhd , block average dif threshold(<) between cur and up block for flat block

**Table 9-973 DNR\_DM\_EDGE\_DIF\_THD2 0x2d6b**

Bit(s)	R/W	Default	Description
31:24	R/W		reserved
23:16	R/W	24	reg_dnr_dm_varthd2, block variance threshold (>=) for edge block detect
15: 8	R/W	40	reg_dnr_dm_edgethd2 , block edge threshold (>=)

**Table 9-974 DNR\_DM\_DIF\_FLT\_MISC 0x2d6c**

Bit(s)	R/W	Default	Description
31:28	R/W	0	reg_dnr_dm_ldiffoob, pre-defined large dif when pixel out of block
27:24	R/W	0	reg_dnr_dm_bdiffoob, pre-defined block dif when pixel out of block
23:16	R/W	200	reg_dnr_dm_ftalp, pre-defined alpha for dm and nr blending when block is flat with mos
15:12	R/W		reserved
11:8	R/W	12	reg_dnr_dm_ftminbdif, pre-defined min block dif for dm filter when block is flat with mos

**Table 9-975 DNR\_DM\_SDIF\_LUT0\_2 0x2d6d**

Bit(s)	R/W	Default	Description
31:21	R/W		reserved
20:16	R/W	16	reg_dnr_dm_sdiflut0, normally 0-16
15:13	R/W		reserved
12:8	R/W	14	reg_dnr_dm_sdiflut1
7:5	R/W		reserved

**Table 9-976 DNR\_DM\_SDIF\_LUT3\_5 0x2d6e**

Bit(s)	R/W	Default	Description
31:21	R/W		reserved
20:16	R/W	10	reg_dnr_dm_sdiflut3
15:13	R/W		reserved
12:8	R/W	7	reg_dnr_dm_sdiflut4
7:5	R/W		reserved

**Table 9-977 DNR\_DM\_SDIF\_LUT6\_8 0x2d6f**

Bit(s)	R/W	Default	Description
31:21	R/W		reserved
20:16	R/W	3	reg_dnr_dm_sdiflut6
15:13	R/W		reserved

Bit(s)	R/W	Default	Description
12:8	R/W	1	reg_dnr_dm_sdiflut7
7:5	R/W		reserved

Table 9-978 DNR\_DM\_LDIF\_LUT0\_2 0x2d70

Bit(s)	R/W	Default	Description
31:21	R/W		reserved
20:16	R/W	0	reg_dnr_dm_ldiflut0
15:13	R/W		reserved
12:8	R/W	4	reg_dnr_dm_ldiflut1
7:5	R/W		reserved

Table 9-979 DNR\_DM\_LDIF\_LUT3\_5 0x2d71

Bit(s)	R/W	Default	Description
31:21	R/W		reserved
20:16	R/W	14	reg_dnr_dm_ldiflut3
15:13	R/W		reserved
12:8	R/W	15	reg_dnr_dm_ldiflut4
7:5	R/W		reserved

Table 9-980 DNR\_DM\_LDIF\_LUT6\_8 0x2d72

Bit(s)	R/W	Default	Description
31:21	R/W		reserved
20:16	R/W	16	reg_dnr_dm_ldiflut6
15:13	R/W		reserved
12:8	R/W	16	reg_dnr_dm_ldiflut7
7:5	R/W		reserved

Table 9-981 DNR\_DM\_DIF2NORM\_LUT0\_2 0x2d73

Bit(s)	R/W	Default	Description
31:21	R/W		reserved
20:16	R/W	16	reg_dnr_dm_dif2normlut0
15:13	R/W		reserved
12:8	R/W	5	reg_dnr_dm_dif2normlut1
7:5	R/W		reserved

Table 9-982 DNR\_DM\_DIF2NORM\_LUT3\_5 0x2d74

Bit(s)	R/W	Default	Description
31:21	R/W		reserved
20:16	R/W	2	reg_dnr_dm_dif2normlut3
15:13	R/W		reserved
12:8	R/W	2	reg_dnr_dm_dif2normlut4
7:5	R/W		reserved

Table 9-983 DNR\_DM\_DIF2NORM\_LUT6\_8 0x2d75

Bit(s)	R/W	Default	Description
31:21	R/W		reserved
20:16	R/W	1	reg_dnr_dm_dif2normlut6
15:13	R/W		reserved
12:8	R/W	1	reg_dnr_dm_dif2normlut7
7:5	R/W		reserved

Table 9-984 DNR\_DM\_GMS\_THD 0x2d76

Bit(s)	R/W	Default	Description
31:16	R/W		reserved
15:8	R/W	0	reg_gms_stat_thd0

Table 9-985 DNR\_RO\_DM\_GMS\_STST\_CNT 0x2d77

Bit(s)	R/W	Default	Description
31:0	RO		ro_dm_gms_stat_cnt

Table 9-986 DNR\_RO\_DM\_GMS\_STST\_MS 0x2d78

Bit(s)	R/W	Default	Description
31:0	RO		ro_dm_gms_stat_ms

Table 9-987 NR2\_POLAR3\_MODE 0x2d98

Bit(s)	R/W	Default	Description
19:18	R/W	3	reg_polar3_f02lpf_mod_0 : default = 3//u2x2: low pass filter mode for field 0 and field2 before polar3 detection; 0 for no lpf, 1: [1 2 1]/4 vert lpf; 2: [1 2 1; 2 4 2; 1 2 1]/16 2d lpf, p1 no hlpf; 2: [1 2 1; 2 4 2; 1 2 1]/16 2d lpf, p1 [1 2 1]/4 hlpf
17:16	R/W	3	reg_polar3_f02lpf_mod_1 : default = 3//u2x2: low pass filter mode for field 0 and field2 before polar3 detection; 0 for no lpf, 1: [1 2 1]/4 vert lpf; 2: [1 2 1; 2 4 2; 1 2 1]/16 2d lpf, p1 no hlpf; 2: [1 2 1; 2 4 2; 1 2 1]/16 2d lpf, p1 [1 2 1]/4 hlpf

Bit(s)	R/W	Default	Description
15:8	R/W	5	reg_polar3_dif02_thrd_0 : default = 5//u8x2: threshold of dif for polar3 detection except for 32 detection, only do polar3 detection on obvious motion, [0] for luma, 1[1] for chroma
7:0	R/W	5	reg_polar3_dif02_thrd_1 : default = 5//u8x2: threshold of dif for polar3 detection except for 32 detection, only do polar3 detection on obvious motion, [0] for luma, 1[1] for chroma

Table 9-988 NR2\_POLAR3\_THRD 0x2d99

Bit(s)	R/W	Default	Description
31:24	R/W	30	reg_polar3_txf02_thrd_0 : default = 30 //u8x2: threshold to vertical f0f2 texture, if texture larger than this threshold, will not do the polar3 decision.
23:16	R/W	30	reg_polar3_txf02_thrd_1 : default = 30 //u8x2: threshold to vertical f0f2 texture, if texture larger than this threshold, will not do the polar3 decision.
15:8	R/W	20	reg_polar3_txf1_thrd_0 : default = 20 //u8x2: threshold to vertical f0f2 texture, if texture larger than this threshold, will not do the polar3 decision.
7:0	R/W	20	reg_polar3_txf1_thrd_1 : default = 20 //u8x2: threshold to vertical f0f2 texture, if texture larger than this threshold, will not do the polar3 decision.

Table 9-989 NR2\_POLAR3\_PARA0 0x2d9a

Bit(s)	R/W	Default	Description
31:28	R/W	6	reg_polar3_rate0_0 : default = 6 //u4x2: $\text{delt} = \text{rate} * \text{dif02} / 32$ , e.g. $f_2 < f_0$ , if $f_1$ within $((f_0 + f_2) / 2 - \text{delt})$ , $((f_0 + f_2) / 2 + \text{delt})$ , then polar3_smoothmv++;
27:24	R/W	6	reg_polar3_rate0_1 : default = 6 //u4x2: $\text{delt} = \text{rate} * \text{dif02} / 32$ , e.g. $f_2 < f_0$ , if $f_1$ within $((f_0 + f_2) / 2 - \text{delt})$ , $((f_0 + f_2) / 2 + \text{delt})$ , then polar3_smoothmv++;
23:20	R/W	8	reg_polar3_rate1_0 : default = 8 //u4x2: $\text{delt} = \text{rate} * \text{dif02} / 32$ , e.g. $f_2 < f_0$ , if $f_1 < ((f_0 + f_2) / 2 - \text{delt})$ , then polar3_m1++; if $f_1 > ((f_0 + f_2) / 2 + \text{delt})$ , then polar3_p1++;
19:16	R/W	8	reg_polar3_rate1_1 : default = 8 //u4x2: $\text{delt} = \text{rate} * \text{dif02} / 32$ , e.g. $f_2 < f_0$ , if $f_1 < ((f_0 + f_2) / 2 - \text{delt})$ , then polar3_m1++; if $f_1 > ((f_0 + f_2) / 2 + \text{delt})$ , then polar3_p1++;
15:12	R/W	2	reg_polar3_rate2_0 : default = 2 //u4x2: $\text{delt} = \text{rate} * \text{dif02} / 32$ , e.g. $f_2 < f_0$ , if $f_1 < (f_2 - \text{delt} - \text{offset}_2)$ , then polar3_m2++; if $f_1 > ((f_0 + \text{delt} + \text{offset}_2)$ , then polar3_p2++;
11:8	R/W	2	reg_polar3_rate2_1 : default = 2 //u4x2: $\text{delt} = \text{rate} * \text{dif02} / 32$ , e.g. $f_2 < f_0$ , if $f_1 < (f_2 - \text{delt} - \text{offset}_2)$ , then polar3_m2++; if $f_1 > ((f_0 + \text{delt} + \text{offset}_2)$ , then polar3_p2++;
7:4	R/W	1	reg_polar3_ofst1_0 : default = 1 //s4x2: $\text{delt} = \text{rate} * \text{dif02} / 32$ , e.g. $f_2 < f_0$ , if $f_1 < (f_2 - \text{delt} - \text{offset}_2)$ , then polar3_m2++; if $f_1 > ((f_0 + \text{delt} + \text{offset}_2)$ , then polar3_p2++;
3:0	R/W	1	reg_polar3_ofst1_1 : default = 1 //s4x2: $\text{delt} = \text{rate} * \text{dif02} / 32$ , e.g. $f_2 < f_0$ , if $f_1 < (f_2 - \text{delt} - \text{offset}_2)$ , then polar3_m2++; if $f_1 > ((f_0 + \text{delt} + \text{offset}_2)$ , then polar3_p2++;

Table 9-990 NR2\_POLAR3\_PARA1 0x2d9b

Bit(s)	R/W	Default	Description
31:24	R/W	48	reg_polar3_rate3_0 : default = 48 //u8x2: $\text{delt} = \text{rate} * \text{dif02} / 32$ , e.g. $f_2 < f_0$ , if $f_1 < (f_2 - \text{delt} - \text{offset}_3)$ or $f_1 > ((f_0 + \text{delt} + \text{offset}_3)$ , then polar3_32++;
23:16	R/W	48	reg_polar3_rate3_1 : default = 48 //u8x2: $\text{delt} = \text{rate} * \text{dif02} / 32$ , e.g. $f_2 < f_0$ , if $f_1 < (f_2 - \text{delt} - \text{offset}_3)$ or $f_1 > ((f_0 + \text{delt} + \text{offset}_3)$ , then polar3_32++;

Bit(s)	R/W	Default	Description
15:12	R/W	2	reg_polar3_ofst3_0 : default = 2 //s4x2: delt = rate*dif02/32, e.g. f2<f0, if f1<(f2 - delt-ofst3) or f1>((f0 + delt+ofst3), then polar3_32++;
11:8	R/W	2	reg_polar3_ofst3_1 : default = 2 //s4x2: delt = rate*dif02/32, e.g. f2<f0, if f1<(f2 - delt-ofst3) or f1>((f0 + delt+ofst3), then polar3_32++;
7:4	R/W	2	reg_polar3_ofst2_0 : default = 2 //s4x2: delt = rate*dif02/32, e.g. f2<f0, if f1<(f2 - delt- ofset2), then polar3_m2++; if f1>((f0 + delt+ ofset2), then polar3_p2++;
3:0	R/W	2	reg_polar3_ofst2_1 : default = 2 //s4x2: delt = rate*dif02/32, e.g. f2<f0, if f1<(f2 - delt- ofset2), then polar3_m2++; if f1>((f0 + delt+ ofset2), then polar3_p2++;

Table 9-991 NR2\_POLAR3\_CTRL 0x2d9c

Bit(s)	R/W	Default	Description
16	R.O	0	reg_polar3_ro_reset : default = 0 //u1: reset signal of the polar3 read only registers
15:8	R/W	10	reg_polar3_h_mute : default = 10//u8: horizontally pixels to mute for left right sides for polar3 detection;
7:0	R/W	10	reg_polar3_v_mute : default = 10//u8: horizontally pixels to mute for top and bottom sides for polar3 detection;

Table 9-992 NR2\_RO\_POLAR3\_NUMOFPIX 0x2d9d

Bit(s)	R/W	Default	Description
23:0	R.O	0	ro_polar3_numofpix : default = 0 //u24, number of pixels detected as polar3

Table 9-993 NR2\_RO\_POLAR3\_SMOOTHMV 0x2d9e

Bit(s)	R/W	Default	Description
23:0	R.O	0	ro_polar3_smoothmv : default = 0 //u24, number of pixels with smooth mv, F(t) is close between avg of f(t-1) and f(t+1);

Table 9-994 NR2\_RO\_POLAR3\_M1 0x2d9f

Bit(s)	R/W	Default	Description
23:0	R.O	0	ro_polar3_m1 : default = 0 //u24, number of pixels with F(t) is close to f(t-1) instead of f(t+1), but in between [f(t-1), f(t+1)];

Table 9-995 NR2\_RO\_POLAR3\_P1 0x2da0

Bit(s)	R/W	Default	Description
23:0	R.O	0	ro_polar3_p1 : default = 0 //u24, number of pixels with F(t) is close to f(t+1) instead of f(t-1), but in between [f(t-1), f(t+1)];

Table 9-996 NR2\_RO\_POLAR3\_M2 0x2da1

Bit(s)	R/W	Default	Description
23:0	R.O	0	ro_polar3_m2 : default = 0 //u24, number of pixels with F(t) is close to f(t-1) instead of f(t+1), but out side of (f(t-1), f(t+1));

Table 9-997 NR2\_RO\_POLAR3\_P2 0x2da2

Bit(s)	R/W	Default	Description
23:0	R.O	0	ro_polar3_p2 : default = 0 //u24, number of pixels with F(t) is close to f(t+1) instead of f(t-1), but out side of (f(t-1), f(t+1));

Table 9-998 NR2\_RO\_POLAR3\_32 0x2da3

Bit(s)	R/W	Default	Description
23:0	R.O	0	ro_polar3_32 : default = 0 //u24, number of pixels with F(t) far from [f(t-1),f(t+1)] and f(t-1) is close to f(t+1);

Table 9-999 NR4\_DRT\_CTRL 0x2da4

Bit(s)	R/W	Default	Description
31:24	R/W	16	reg_nr4_ydrt_3line_ssd_gain : // unsigned , default = 16 gain to max ssd normalized 16 as '1'
23:16	R/W	16	reg_nr4_ydrt_5line_ssd_gain : // unsigned , default = 16 gain to max ssd normalized 16 as '1'
14:13	R/W	1	reg_nr4_drt_yhsad_mode : // unsigned , default = 1 mode for luma horizontal sad calc., 0: no vertical lpf, 1: vertical [1 2 1], 2 or 3: vertical [1 2 2 2 1] if 5 lines
12:11	R/W	1	reg_nr4_drt_chsad_mode : // unsigned , default = 1 mode for chroma horizontal sad calc., 0: no vertical lpf, 1: vertical [1 2 1], 2 or 3: vertical [1 2 2 2 1] if 5 lines
10	R/W	1	reg_nr4_drt_yhsad_hlpf : // unsigned , default = 1 hlpf for luma hsad of drt calculation, 0: no lpf, 1: with [1 2 1] hlpf
9	R/W	1	reg_nr4_drt_yvsad_hlpf : // unsigned , default = 1 hlpf for luma vsad of drt calculation, 0: no lpf, 1: with [1 2 1] hlpf
8	R/W	1	reg_nr4_drt_ydsad_hlpf : // unsigned , default = 1 hlpf for luma dsad of drt calculation, 0: no lpf, 1: with [1 2 1] hlpf
7	R/W	1	reg_nr4_drt_chsad_hlpf : // unsigned , default = 1 hlpf for chrome hsad of drt calculation, 0: no lpf, 1: with [1 2 1] hlpf
6	R/W	1	reg_nr4_drt_cvsad_hlpf : // unsigned , default = 1 hlpf for chroma vsad of drt calculation, 0: no lpf, 1: with [1 2 1] hlpf
5	R/W	1	reg_nr4_drt_cdsad_hlpf : // unsigned , default = 1 hlpf for chroma dsad of drt calculation, 0: no lpf, 1: with [1 2 1] hlpf
4	R/W	1	reg_nr4_ydrt_dif_mode : // unsigned , default = 1 0:y_dif, 1: y_dif + (u_dif + v_dif)/2
3: 2	R/W	2	reg_nr4_cdrd_dif_mode : // unsigned , default = 2 0:(u_dif + v_dif), 1: y_dif/4 + (u_dif + v_dif)*3/4, 2:y_dif/2 + (u_dif + v_dif)/2, 3: y_dif (not recommended)
1:0	R/W		reserved



**Table 9-1000 NR4\_DRT\_YSAD\_GAIN 0x2da5**

Bit(s)	R/W	Default	Description
31:24	R/W	16	reg_nr4_ysad_hrz_gain : // unsigned , default = 16 gain for horizontal sad, 16 normalized to "1"
23:16	R/W	20	reg_nr4_ysad_diag_gain : // unsigned , default = 20 gain for diagonal sad, 16 normalized to "1"
15: 8	R/W	16	reg_nr4_ysad_vrt_gain : // unsigned , default = 16 gain for vertical sad, 16 normalized to "1"
5: 0	R/W	6	reg_nr4_drt_ysad_core_rate : // unsigned , default = 6 rate of coring for sad(theta) - sad(theta+pi/2)*rate/64

**Table 9-1001 NR4\_DRT\_CSAD\_GAIN 0x2da6**

Bit(s)	R/W	Default	Description
31:24	R/W	16	reg_nr4_csad_hrz_gain : // unsigned , default = 16 gain for horizontal sad, 16 normalized to "1"
23:16	R/W	20	reg_nr4_csad_diag_gain : // unsigned , default = 20 gain for diagonal sad, 16 normalized to "1"
15: 8	R/W	16	reg_nr4_csad_vrt_gain : // unsigned , default = 16 gain for vertical sad, 16 normalized to "1"
5: 0	R/W	6	reg_nr4_drt_csad_core_rate : // unsigned , default = 6 rate of coring for sad(theta) - sad(theta+pi/2)*rate/64

**Table 9-1002 NR4\_DRT\_SAD\_ALP\_CORE 0x2da7**

Bit(s)	R/W	Default	Description
23:20	R/W	0	reg_nr4_ydrt_alp_core_rate : // unsigned , default = 0 luma ratio to min_err, alpha = (min_err - (max_err - min_err)*rate + ofst)/max_err * 64; dft = 0/32
19:16	R/W	0	reg_nr4_cdrt_alp_core_rate : // unsigned , default = 0 chroma ratio to min_err, alpha = (min_err - (max_err - min_err)*rate + ofst)/max_err * 64; dft = 0/32
13: 8	R/W	10	reg_nr4_ydrt_alp_core_ofst : // unsigned , default = 10 luma offset to min_err, alpha = (min_err - (max_err - min_err)*rate + ofst)/max_err * 64; dft = 10
5: 0	R/W	10	reg_nr4_cdrt_alp_core_ofst : // unsigned , default = 10 chroma offset to min_err, alpha = (min_err - (max_err - min_err)*rate + ofst)/max_err * 64; dft = 10

**Table 9-1003 NR4\_DRT\_ALP\_MINMAX 0x2da8**

Bit(s)	R/W	Default	Description
29:24	R/W	0	reg_nr4_ydrt_alp_min : // unsigned , default = 0 luma min value of alpha, dft = 0
21:16	R/W	63	reg_nr4_ydrt_alp_max : // unsigned , default = 63 luma max value of alpha, dft = 63
13: 8	R/W	0	reg_nr4_cdrt_alp_min : // unsigned , default = 0 chroma min value of alpha, dft = 0
5: 0	R/W	63	reg_nr4_cdrt_alp_max : // unsigned , default = 63 chroma max value of alpha, dft = 63

Table 9-1004 NR4\_SNR\_CTRL\_REG 0x2da9

Bit(s)	R/W	Default	Description
12	R/W	1	reg_nr4_bet2_sel : // unsigned , default = 1
11: 9	R/W	0	reg_nr4_snr2_sel_mode : // unsigned , default = 0 0: no filter, 1: adpgau, adp_drt_lpf blend; 2: adpgau, drt4_lpf blend; 3: adp_drt_lpf method, 4: drt4_lpf method, 5: adp_drt_//original image blend, 6: drt4_lpf, original image blend, 7: adpgau method; dft=1
8	R/W	1	reg_nr4_snr2_gaulpf_mode : // unsigned , default = 1 0: 3*5 or 5*5 gaussian lpf; 1: 3*3 (window size) gaussian lpf; dft=1
7: 6	R/W	3	reg_nr4_snr2_alpha0_sad_mode : // unsigned , default = 3 0: max_sad*max_ssd; 1: max_sad*max_sad; 2: adp_max_sad*max_ssd; 3: adp_max_sad*adp_max_sad dft=3
5: 4	R/W	2	reg_nr4_snr2_alpha1_sad_mode : // unsigned , default = 2 0: max_sad; 1: cross_max_sad; 2 or 3: adp_sad dft=2
1: 0	R/W	3	reg_nr4_snr2_adp_drtlpf_mode : // unsigned , default = 3 0: adp_drtlpf [2 1 1]/4, 1: adp_drtlpf [4 2 1 1]/8; 2: adp_drtlpf [2 2 2 1 1]/8; 3: adp_drtlpf [7 7 7 6 5]/32; dft=3;

Table 9-1005 NR4\_SNR\_ALPHA0\_MAX\_MIN 0x2daa

Bit(s)	R/W	Default	Description
29:23	R/W	127	reg_nr4_snr2_alp0_ymin : // unsigned , default = 127 normalized to 128 as '1'
22:16	R/W	127	reg_nr4_snr2_alp0_ymax : // unsigned , default = 127 normalized to 128 as '1'
13: 7	R/W	127	reg_nr4_snr2_alp0_cmin : // unsigned , default = 127 normalized to 128 as '1'
6: 0	R/W	127	reg_nr4_snr2_alp0_cmax : // unsigned , default = 127 normalized to 128 as '1'

Table 9-1006 NR4\_ALP0C\_ERR2CURV\_LIMIT0 0x2dab

Bit(s)	R/W	Default	Description
31:24	R/W	0	reg_nr4_snr2_alp0_minerr_cpar0 : // unsigned , default = 0 threshold0 of curve to map mierr to alp0 for chroma channel, this will be set value of flat region mierr that no need blur.
23:16	R/W	25	reg_nr4_snr2_alp0_minerr_cpar1 : // unsigned , default = 25 threshold1 of curve to map mierr to alp0 for chroma channel, this will be set value of texture region mierr that can not blur.
15: 8	R/W	40	reg_nr4_snr2_alp0_minerr_cpar5 : // unsigned , default = 40 rate0 (for mierr<th0) of curve to map mierr to alp0 for chroma channel. the larger of the value, the deep of the slope. 0~255.
7: 0	R/W	40	reg_nr4_snr2_alp0_minerr_cpar6 : // unsigned , default = 40 rate1 (for mierr>th1) of curve to map mierr to alp0 for chroma channel. the larger of the value, the deep of the slope. 0~255.

**Table 9-1007 NR4\_ALP0C\_ERR2CURV\_LIMIT1 0x2dac**

Bit(s)	R/W	Default	Description
23:16	R/W	127	reg_nr4_snr2_alp0_minerr_cpar2 : // unsigned , default = 127 level limit(for mierr<th0) of curve to map mierr to alp0 for chroma channel, that we can do for flat region. 0~255.
15: 8	R/W	0	reg_nr4_snr2_alp0_minerr_cpar3 : // unsigned , default = 0 level limit(for th0<mierr<th1) of curve to map mierr to alp0 for chroma channel, that we can do for misc region. 0~255.
7: 0	R/W	127	reg_nr4_snr2_alp0_minerr_cpar4 : // unsigned , default = 127 level limit(for mierr>th1) of curve to map mierr to alp0 for chroma channel, that we can do for texture region. 0~255.

**Table 9-1008 NR4\_ALP0Y\_ERR2CURV\_LIMIT0 0x2dad**

Bit(s)	R/W	Default	Description
31:24	R/W	0	reg_nr4_snr2_alp0_minerr_ypar0 : // unsigned , default = 0 threshold0 of curve to map mierr to alp0 for luma channel, this will be set value of flat region mierr that no need blur. 0~255.
23:16	R/W	25	reg_nr4_snr2_alp0_minerr_ypar1 : // unsigned , default = 25 threshold1 of curve to map mierr to alp0 for luma channel,this will be set value of texture region mierr that can not blur.
15: 8	R/W	40	reg_nr4_snr2_alp0_minerr_ypar5 : // unsigned , default = 40 rate0 (for mierr<th0) of curve to map mierr to alp0 for luma channel. the larger of the value, the deep of the slope. 0~255.
7: 0	R/W	40	reg_nr4_snr2_alp0_minerr_ypar6 : // unsigned , default = 40 rate1 (for mierr>th1) of curve to map mierr to alp0 for luma channel. the larger of the value, the deep of the slope. 0~255.

**Table 9-1009 NR4\_ALP0Y\_ERR2CURV\_LIMIT1 0x2dae**

Bit(s)	R/W	Default	Description
23:16	R/W	127	reg_nr4_snr2_alp0_minerr_ypar2 : // unsigned , default = 127 level limit(for mierr<th0) of curve to map mierr to alp0 for luma channel, set to alp0 that we can do for flat region. 0~255.
15: 8	R/W	0	reg_nr4_snr2_alp0_minerr_ypar3 : // unsigned , default = 0 level limit(for th0<mierr<th1) of curve to map mierr to alp0 for luma channel, alp0 that we can do for misc region. 0~255.
7: 0	R/W	127	reg_nr4_snr2_alp0_minerr_ypar4 : // unsigned , default = 127 level limit(for mierr>th1) of curve to map mierr to alp0 for luma channel, alp0 that we can do for texture region. 0~255.

**Table 9-1010 NR4\_SNR\_ALPA1\_RATE\_AND\_OFST 0x2daf**

Bit(s)	R/W	Default	Description
23:18	R/W	0	reg_nr4_snr2_alp1_ycore_rate : // unsigned , default = 0 normalized 64 as "1"
17:12	R/W	0	reg_nr4_snr2_alp1_ccore_rate : // unsigned , default = 0 normalized 64 as "1"
11: 6	R/W	3	reg_nr4_snr2_alp1_ycore_ofst : // signed , default = 3 normalized 64 as "1"
5: 0	R/W	3	reg_nr4_snr2_alp1_ccore_ofst : // signed , default = 3 normalized 64 as "1"

**Table 9-1011 NR4\_SNR\_ALPHA1\_MAX\_MIN 0x2db0**

Bit(s)	R/W	Default	Description
23:18	R/W	0	reg_nr4_snr2_alp1_ymin : // unsigned , default = 0 normalized to 64 as '1'
17:12	R/W	63	reg_nr4_snr2_alp1_ymax : // unsigned , default = 63 normalized to 64 as '1'
11: 6	R/W	0	reg_nr4_snr2_alp1_cmin : // unsigned , default = 0 normalized to 64 as '1'
5: 0	R/W	63	reg_nr4_snr2_alp1_cmax : // unsigned , default = 63 normalized to 64 as '1'

**Table 9-1012 NR4\_ALP1C\_ERR2CURV\_LIMIT0 0x2db1**

Bit(s)	R/W	Default	Description
31:24	R/W	0	reg_nr4_snr2_alp1_minerr_cpar0 : // unsigned , default = 0 anel, this will be set value of flat region mierr that no need directional NR. 0~255.
23:16	R/W	24	reg_nr4_snr2_alp1_minerr_cpar1 : // unsigned , default = 24 hannel,this will be set value of texture region mierr that can not do directional NR. 0~255.
15: 8	R/W	0	reg_nr4_snr2_alp1_minerr_cpar5 : // unsigned , default = 0 a/chroma channel. the larger of the value, the deep of the slope.
7: 0	R/W	20	reg_nr4_snr2_alp1_minerr_cpar6 : // unsigned , default = 20 a/chroma channel. the larger of the value, the deep of the slope. 0~255

**Table 9-1013 NR4\_ALP1C\_ERR2CURV\_LIMIT1 0x2db2**

Bit(s)	R/W	Default	Description
23:16	R/W	0	reg_nr4_snr2_alp1_minerr_cpar2 : // unsigned , default = 0 will be set to alp1 that we can do for flat region. 0~255.
15: 8	R/W	16	reg_nr4_snr2_alp1_minerr_cpar3 : // unsigned , default = 16 this will be set to alp1 that we can do for misc region. 0~255.
7: 0	R/W	63	reg_nr4_snr2_alp1_minerr_cpar4 : // unsigned , default = 63 will be set to alp1 that we can do for texture region. 0~255.255 before

**Table 9-1014 NR4\_ALP1Y\_ERR2CURV\_LIMIT0 0x2db3**

Bit(s)	R/W	Default	Description
31:24	R/W	0	reg_nr4_snr2_alp1_minerr_ypar0 : // unsigned , default = 0 thra/chroma channel, this will be set value of flat region mierr that no need directional NR. 0~255.
23:16	R/W	24	reg_nr4_snr2_alp1_minerr_ypar1 : // unsigned , default = 24 thra/chroma channel,this will be set value of texture region mierr that can not do directional NR. 0~255.
15: 8	R/W	0	reg_nr4_snr2_alp1_minerr_ypar5 : // unsigned , default = 0 ratlp1 for luma/chroma channel. the larger of the value, the deep of the slope.
7: 0	R/W	20	reg_nr4_snr2_alp1_minerr_ypar6 : // unsigned , default = 20 ratlp1 for luma/chroma channel. the larger of the value, the deep of the slope. 0~255

**Table 9-1015 NR4\_ALP1Y\_ERR2CURV\_LIMIT1 0x2db4**

Bit(s)	R/W	Default	Description
23:16	R/W	0	reg_nr4_snr2_alp1_minerr_ypar2 : // unsigned , default = 0 lev to alp1 for luma/chroma channel, this will be set to alp1 that we can do for flat region. 0~255.
15: 8	R/W	16	reg_nr4_snr2_alp1_minerr_ypar3 : // unsigned , default = 16 lev to alp1 for luma/chroma channel, this will be set to alp1 that we can do for misc region. 0~255.
7: 0	R/W	63	reg_nr4_snr2_alp1_minerr_ypar4 : // unsigned , default = 63 lev to alp1 for luma/chroma channel, this will be set to alp1 that we can do for texture region. 0~255.255 before

**Table 9-1016 NR4\_MTN\_CTRL 0x2db5**

Bit(s)	R/W	Default	Description
1	R/W	1	reg_nr4_mtn_ref_en : // unsigned , default = 1 enable motion refinement, dft = 1
0	R/W	0	reg_nr4_mtn_ref_bet_sel : // unsigned , default = 0 beta selection mode for motion refinement, 0: beta1, 1: beta2, dft = 0

**Table 9-1017 NR4\_MTN\_REF\_PAR0 0x2db6**

Bit(s)	R/W	Default	Description
31:24	R/W	24	reg_nr4_mtn_ref_par0 : // unsigned , default = 24 par0 for beta to gain, dft =
23:16	R/W	60	reg_nr4_mtn_ref_par1 : // unsigned , default = 60 par1 for beta to gain, dft =
15: 8	R/W	4	reg_nr4_mtn_ref_par2 : // unsigned , default = 4 par2 for beta to gain, dft =
7: 0	R/W	32	reg_nr4_mtn_ref_par3 : // unsigned , default = 32 par3 for beta to gain, dft =

**Table 9-1018 NR4\_MTN\_REF\_PAR1 0x2db7**

Bit(s)	R/W	Default	Description
23:16	R/W	128	reg_nr4_mtn_ref_par4 : // unsigned , default = 128 par4 for beta to gain, dft =
15: 8	R/W	40	reg_nr4_mtn_ref_par5 : // unsigned , default = 40 par5 for beta to gain, dft =
7: 0	R/W	20	reg_nr4_mtn_ref_par6 : // unsigned , default = 20 par6 for beta to gain, dft =

**Table 9-1019 NR4\_MCNR\_LUMA\_ENH\_CTRL 0x2db8**

Bit(s)	R/W	Default	Description
3	R/W	1	reg_nr4_luma_plus_en : // unsigned , default = 1 enable luma enhancement, dft = 1
2	R/W	1	reg_nr4_luma_plus_wt_mode : // unsigned , default = 1 luma weight calc mode, 0:sqrt(1+x^2), 1: 1+abs(x), dft = 0
1: 0	R/W	1	reg_nr4_luma_plus_orient_mode : // unsigned , default = 1 0: only use previous orient for pre and cur luma plus, 1: 0: only use current orient for pre and cur luma plus

**Table 9-1020 NR4\_MCNR\_LUMA\_STAT\_LIMTX 0x2db9**

Bit(s)	R/W	Default	Description
29:16	R/W	8	reg_nr4_luma_plus_xst : // unsigned , default = 8 start for luma plus statistic, dft = 8
13: 0	R/W	711	reg_nr4_luma_plus_xed : // unsigned , default = 711 end for luma plus statistic, dft = HSIZE-8-1;

**Table 9-1021 NR4\_MCNR\_LUMA\_STAT\_LIMTY 0x2dba**

Bit(s)	R/W	Default	Description
29:16	R/W	8	reg_nr4_luma_plus_yst : // unsigned , default = 8 start for luma plus statistic, dft = 8
13: 0	R/W	231	reg_nr4_luma_plus_yed : // unsigned , default = 231 end for luma plus statistic, dft = VSIZE-8-1

**Table 9-1022 NR4\_MCNR\_LUMA\_DIF\_CALC 0x2dbb**

Bit(s)	R/W	Default	Description
29:24	R/W	8	reg_nr4_luma_plus_ugain : // unsigned , default = 8 U's gain for luma enhancement, 16 normalized as '1'
21:16	R/W	8	reg_nr4_luma_plus_vgain : // unsigned , default = 8 V's gain for luma enhancement, 16 normalized as '1'
15: 8	R/W	2	reg_nr4_luma_plus_ycor_thd : // unsigned , default = 2 Y coring threshold for difference calc., dft = 0
7: 0	R/W	0	reg_nr4_luma_plus_ccor_thd : // unsigned , default = 0 C coring threshold for difference calc., dft = 0

**Table 9-1023 NR4\_MCNR\_LUMAPRE\_CAL\_PRAM 0x2dbc**

Bit(s)	R/W	Default	Description
25:24	R/W	0	reg_nr4_pre_u_orient : // signed , default = 0 orientation of previous U, initial to 0, and will be updated by software
17:16	R/W	0	reg_nr4_pre_v_orient : // signed , default = 0 orientation of previous V, initial to 0, and will be updated by software
15: 8	R/W	0	reg_nr4_pre_u_mean : // unsigned , default = 0 mean of previous U, initial to 0, and will be updated by software
7: 0	R/W	0	reg_nr4_pre_v_mean : // unsigned , default = 0 mean of previous V, initial to 0, and will be updated by software

**Table 9-1024 NR4\_MCNR\_LUMACUR\_CAL\_PRAM 0x2dbd**

Bit(s)	R/W	Default	Description
25:24	R/W	0	reg_nr4_cur_u_orient : // signed , default = 0 orientation of current U, initial to 0, and will be updated by software
17:16	R/W	0	reg_nr4_cur_v_orient : // signed , default = 0 orientation of current V, initial to 0, and will be updated by software

Bit(s)	R/W	Default	Description
15: 8	R/W	0	reg_nr4_cur_u_mean : // unsigned , default = 0 mean of current U, initial to 0, and will be updated by software
7: 0	R/W	0	reg_nr4_cur_v_mean : // unsigned , default = 0 mean of current, initial to 0, and will be updated by software

Table 9-1025 NR4\_MCNR\_MV\_CTRL\_REG 0x2dbe

Bit(s)	R/W	Default	Description
13:12	R/W	2	reg_nr4_sad_bitw : // unsigned , default = 2 sad bit width (8 + x) before clip to u8, dft = 1
11: 4	R/W	64	reg_nr4_glb_gain : // unsigned , default = 64 global gain calc. by software, 64 is normalized as '1'
3: 0	R/W	8	reg_nr4_mv_err_rsft : // unsigned , default = 8 right shift for mv err calc., dft = 9

Table 9-1026 NR4\_MCNR\_MV\_GAIN0 0x2dbf

Bit(s)	R/W	Default	Description
31:28	R/W	1	reg_nr4_lftmvx_gain : // unsigned , default = 1 left mvx gain for err calc., dft = 1
27:24	R/W	1	reg_nr4_lftmvy_gain : // unsigned , default = 1 left mvy gain for err calc., dft = 1
23:20	R/W	5	reg_nr4_zmvx_gain : // unsigned , default = 5 zero mvx gain for err calc., dft = 2
19:16	R/W	5	reg_nr4_zmvy_gain : // unsigned , default = 5 zero mvy gain for err calc., dft = 4
15:12	R/W	2	reg_nr4_lmxx0_gain : // unsigned , default = 2 line mvx0 gain for err calc., dft = 1
11: 8	R/W	2	reg_nr4_lmxx1_gain : // unsigned , default = 2 line mvx1 gain for err calc., dft = 1
7: 4	R/W	2	reg_nr4_lmvy0_gain : // unsigned , default = 2 line mvy0 gain for err calc., dft = 1
3: 0	R/W	2	reg_nr4_lmvy1_gain : // unsigned , default = 2 line mvy1 gain for err calc., dft = 1

Table 9-1027 NR4\_MCNR\_LMV\_PARM 0x2dc0

Bit(s)	R/W	Default	Description
31:28	R/W	3	reg_nr4_lmvr_t0 : // unsigned , default = 3 ratio of max lmv
27:24	R/W	3	reg_nr4_lmvr_t1 : // unsigned , default = 3 ratio of second max lmv
21:16	R/W	16	reg_nr4_lmvr_num_lmt0 : // unsigned , default = 16 lmv0 least/limit number of (total number - zero_bin)
13: 8	R/W	8	reg_nr4_lmvr_num_lmt1 : // unsigned , default = 8 lmv1 least/limit number of (total number - zero_bin - max0)
1: 0	R/W	1	reg_nr4_max_sad_rng : // unsigned , default = 1 search range of max2 sad in small region, dft = 1

Table 9-1028 NR4\_MCNR\_ALP0\_REG 0x2dc1

Bit(s)	R/W	Default	Description
25	R/W	1	reg_nr4_alp0_fail_chk : // unsigned , default = 1 enable check for alp0 fail status
24	R/W	1	reg_nr4_bet0_coef_ref_en : // unsigned , default = 1 bet1 refinement by coef_blt
23:16	R/W	255	reg_nr4_alp0_posad_gain : // unsigned , default = 255 the sad (norm) gain for pixel pointed by MV;
9: 8	R/W	0	reg_nr4_alp0_norm_mode : // unsigned , default = 0 alp0 select sad norm mode, 0: disable, 1: enable dc norm, 2: enable ac norm, 3: enable both (dc/ac) norm, dft = 3
5: 0	R/W	16	reg_nr4_alp0_norm_gain : // unsigned , default = 16 alp0 gain for sad norm, '32' as '1', dft = 1

Table 9-1029 NR4\_MCNR\_ALP1\_AND\_BET0\_REG 0x2dc2

Bit(s)	R/W	Default	Description
25:24	R/W	3	reg_nr4_alp1_norm_mode : // unsigned , default = 3 alp1 select sad norm mode, 0: disable, 1: enable dc norm, 2: enable ac norm, 3: enable both (dc/ac) norm, dft = 3
21:16	R/W	3	reg_nr4_alp1_norm_gain : // unsigned , default = 3 alp1 gain for sad norm, '32' as '1', dft = 1
9: 8	R/W	3	reg_nr4_bet0_norm_mode : // unsigned , default = 3 bet0 select sad norm mode, 0: disable, 1: enable dc norm, 2: enable ac norm, 3: enable both (dc/ac) norm, dft = 3
5: 0	R/W	8	reg_nr4_bet0_norm_gain : // unsigned , default = 8 bet0 gain for sad norm, '32' as '1', dft = 1

Table 9-1030 NR4\_MCNR\_BET1\_AND\_BET2\_REG 0x2dc3

Bit(s)	R/W	Default	Description
25:24	R/W	3	reg_nr4_bet1_norm_mode : // unsigned , default = 3 bet1 select sad norm mode, 0: disable, 1: enable dc norm, 2: enable ac norm, 3: enable both (dc/ac) norm, dft = 3
21:16	R/W	8	reg_nr4_bet1_norm_gain : // unsigned , default = 8 bet1 gain for sad norm, '32' as '1', dft = 1
9: 8	R/W	0	reg_nr4_bet2_norm_mode : // unsigned , default = 0 bet2 select sad norm mode, 0: disable, 1: enable dc norm, 2: enable ac norm, 3: enable both (dc/ac) norm, dft = 3
5: 0	R/W	16	reg_nr4_bet2_norm_gain : // unsigned , default = 16 bet2 gain for sad norm, '32' as '1', dft = 1

Table 9-1031 NR4\_MCNR\_AC\_DC\_CRTL 0x2dc4

Bit(s)	R/W	Default	Description
11	R/W	1	reg_nr4_dc_mode : // unsigned , default = 1 mode for dc selection, 0: Y_lpf, 1: Y_lpf + (U_lpf+V_lpf)/2,
10	R/W	1	reg_nr4_ac_mode : // unsigned , default = 1 mode for ac selection, 0: Y_abs_dif, 1: Y_abs_dif + (U_abs_dif + V_abs_dif)/2
9	R/W	0	reg_nr4_dc_sel : // unsigned , default = 0 selection mode for dc value, 0: 3x5, 1: 5x5, dft = 1



Bit(s)	R/W	Default	Description
8	R/W	0	reg_nr4_ac_sel : // unsigned , default = 0 selection mode for ac value, 0: 3x5, 1: 5x5, dft = 1
6: 4	R/W	2	reg_nr4_dc_shft : // unsigned , default = 2 right shift for dc value, dft = 2
2: 0	R/W	0	reg_nr4_ac_shft : // unsigned , default = 0 right shift for ac value, dft = 2

Table 9-1032 NR4\_MCNR\_CM\_CTRL0 0x2dc5

Bit(s)	R/W	Default	Description
28	R/W	0	reg_nr4_cm_skin_prc_bet0 : // unsigned , default = 0 enable skin tone processing for mcnr bet0 calc., dft = 1
27:26	R/W	1	reg_nr4_cm_chrm_sel : // unsigned , default = 1 chrome selection for color match, 0: 1x1, 1: 3X3LPF, 2: 3x5LPF, 3: 5x5LPF for 5lines, 3x5LPF for 3lines, dft = 3
25:24	R/W	1	reg_nr4_cm_luma_sel : // unsigned , default = 1 luma selection for color match, 0: 1x1, 1: 3X3LPF, 2: 3x5LPF, 3: 5x5LPF for 5lines, 3x5LPF for 3lines, dft = 3
23:21	R/W	3	reg_nr4_cm_skin_rshft_bet0 : // unsigned , default = 3 right shift for bet0's skin color gains, dft = 3
20	R/W	1	reg_nr4_cm_var_sel : // unsigned , default = 1 variation selection for color match, 0: 3x5, 1: 5x5 for 5lines, 3x5 for 3lines, dft = 1
19	R/W	1	reg_nr4_cm_green_prc_bet0 : // unsigned , default = 1 enable green processing for mcnr bet0 calc., dft = 1
18:16	R/W	4	reg_nr4_cm_green_rshft_bet0 : // unsigned , default = 4 right shift for bet0's green color gains, dft = 4
15:14	R/W	2	reg_nr4_prefft_mod : // unsigned , default = 2 pre filter mode in mcnr, 0: mv pointed pixel, 1: bilater filter
13:12	R/W	1	reg_nr4_alp1_mode : // unsigned , default = 1 mode for alpha1's sad selection, 0: max sad, 1: three min sads, 2: min sad, 3: co sad
9: 8	R/W	0	reg_nr4_bet0_mode : // unsigned , default = 0 mode for bet0's sad selection, 0: max sad, 1: three min sads, 2: min sad, 3: co sad, else: (co sad) - (min sad)
5: 4	R/W	2	reg_nr4_bet1_mode : // unsigned , default = 2 mode for bet1's sad selection, 0: max sad, 1: three min sads, 2: min sad, 3: co sad, else: (co sad) - (min sad)
1: 0	R/W	1	reg_nr4_bet2_mode : // unsigned , default = 1 mode for bet2's sad selection, 0: max sad, 1: three min sads, 2: min sad, 3: co sad, else: (co sad) - (min sad)

Table 9-1033 NR4\_MCNR\_CM\_PRAM 0x2dc6

Bit(s)	R/W	Default	Description
29	R/W	1	reg_nr4_cm_blue_prc_alp0 : // unsigned , default = 1 enable blue processing for mcnr alpha0 calc., dft = 1
28	R/W	1	reg_nr4_cm_blue_prc_alp1 : // unsigned , default = 1 enable blue processing for mcnr alpha1 calc., dft = 1
27	R/W	1	reg_nr4_cm_skin_prc_alp0 : // unsigned , default = 1 enable skin tone processing for mcnr alpha0 calc., dft = 1
26	R/W	1	reg_nr4_cm_green_prc_alp0 : // unsigned , default = 1 enable green processing for mcnr alpha0 clac., dft = 1

Bit(s)	R/W	Default	Description
25	R/W	1	reg_nr4_cm_skin_prc_alp1 : // unsigned , default = 1 enable skin tone processing for mcnr alpha0 calc., dft = 1
24	R/W	1	reg_nr4_cm_green_prc_alp1 : // unsigned , default = 1 enable green processing for mcnr alpha1 clac., dft = 1
23:20	R/W	13	reg_nr4_cm_blue_hue_st : // unsigned , default = 13 hue start of blue, dft =
19:16	R/W	15	reg_nr4_cm_blue_hue_ed : // unsigned , default = 15 hue end of blue, dft =
15:12	R/W	7	reg_nr4_cm_green_hue_st : // unsigned , default = 7 hue start of green, dft =
11: 8	R/W	10	reg_nr4_cm_green_hue_ed : // unsigned , default = 10 hue end of green, dft =
7: 4	R/W	5	reg_nr4_cm_skin_hue_st : // unsigned , default = 5 hue start of skin, dft =
3: 0	R/W	6	reg_nr4_cm_skin_hue_ed : // unsigned , default = 6 hue end of skin, dft =

Table 9-1034 NR4\_MCNR\_CM\_RSHFT\_ALP0 0x2dc7

Bit(s)	R/W	Default	Description
27:25	R/W	5	reg_nr4_cm_blue_rshft_bet0 : // unsigned , default = 5 right shift for bet0's blue color gains, dft = 5
24	R/W	1	reg_nr4_cm_blue_prc_bet0 : // unsigned , default = 1 enable blue processing for mcnr bet0 calc., dft = 1
22:20	R/W	5	reg_nr4_cm_blue_rshft_alp0 : // unsigned , default = 5 right shift for alpha0/1's blue color gains, dft = 5
18:16	R/W	5	reg_nr4_cm_blue_rshft_alp1 : // unsigned , default = 5 right shift for alpha0/1's blue color gains, dft = 5
14:12	R/W	4	reg_nr4_cm_green_rshft_alp0 : // unsigned , default = 4 right shift for alpha0/1's green color gains, dft = 4
10: 8	R/W	4	reg_nr4_cm_green_rshft_alp1 : // unsigned , default = 4 right shift for alpha0/1's green color gains, dft = 4
6: 4	R/W	3	reg_nr4_cm_skin_rshft_alp0 : // unsigned , default = 3 right shift for alpha0/1's skin color gains, dft = 3
2: 0	R/W	3	reg_nr4_cm_skin_rshft_alp1 : // unsigned , default = 3 right shift for alpha0/1's skin color gains, dft = 3

Table 9-1035 NR4\_MCNR\_BLUE\_CENT 0x2dc8

Bit(s)	R/W	Default	Description
23:16	R/W	157	reg_nr4_cm_blue_centx : // unsigned , default = 157 x coordinate of center of blue, dft =
7: 0	R/W	110	reg_nr4_cm_blue_centy : // unsigned , default = 110 y coordinate of center of blue, dft =

Table 9-1036 NR4\_MCNR\_BLUE\_GAIN\_PAR0 0x2dc9

Bit(s)	R/W	Default	Description
31:24	R/W	32	reg_nr4_cm_blue_gain_par0 : // unsigned , default = 32 par0 for blue gain, dft =
23:16	R/W	255	reg_nr4_cm_blue_gain_par1 : // unsigned , default = 255 par1 for blue gain, dft =

Bit(s)	R/W	Default	Description
15: 8	R/W	4	reg_nr4_cm_blue_gain_par2 : // unsigned , default = 4 par2 for blue gain, dft =
7: 0	R/W	32	reg_nr4_cm_blue_gain_par3 : // unsigned , default = 32 par3 for blue gain, dft =

Table 9-1037 NR4\_MCNR\_BLUE\_GAIN\_PAR1 0x2dca

Bit(s)	R/W	Default	Description
23:16	R/W	32	reg_nr4_cm_blue_gain_par4 : // unsigned , default = 32 par4 for blue gain, dft =
15: 8	R/W	32	reg_nr4_cm_blue_gain_par5 : // unsigned , default = 32 par5 for blue gain, dft =
7: 0	R/W	0	reg_nr4_cm_blue_gain_par6 : // unsigned , default = 0 par6 for blue gain, dft =

Table 9-1038 NR4\_MCNR\_CM\_BLUE\_CLIP0 0x2dcb

Bit(s)	R/W	Default	Description
23:16	R/W	40	reg_nr4_cm_blue_luma_min : // unsigned , default = 40 luma min for blue color matching, dft =
7: 0	R/W	180	reg_nr4_cm_blue_luma_max : // unsigned , default = 180 luma max for blue color matching, dft =

Table 9-1039 NR4\_MCNR\_CM\_BLUE\_CLIP1 0x2dcc

Bit(s)	R/W	Default	Description
31:24	R/W	5	reg_nr4_cm_blue_sat_min : // unsigned , default = 5 saturation min for blue color matching, dft =
23:16	R/W	255	reg_nr4_cm_blue_sat_max : // unsigned , default = 255 saturation max for blue color matching, dft =
15: 8	R/W	0	reg_nr4_cm_blue_var_min : // unsigned , default = 0 variation min for blue color matching, dft =
7: 0	R/W	12	reg_nr4_cm_blue_var_max : // unsigned , default = 12 variation max for blue color matching, dft =

Table 9-1040 NR4\_MCNR\_GREEN\_CENT 0x2dcd

Bit(s)	R/W	Default	Description
23:16	R/W	114	reg_nr4_cm_green_cenx : // unsigned , default = 114 x coordinate of center of green, dft =
7: 0	R/W	126	reg_nr4_cm_green_ceny : // unsigned , default = 126 y coordinate of center of green, dft =

**Table 9-1041 NR4\_MCNR\_GREEN\_GAIN\_PAR0 0x2dce**

Bit(s)	R/W	Default	Description
31:24	R/W	16	reg_nr4_cm_green_gain_par0 : // unsigned , default = 16 par0 for green gain, dft =
23:16	R/W	255	reg_nr4_cm_green_gain_par1 : // unsigned , default = 255 par1 for green gain, dft =
15: 8	R/W	255	reg_nr4_cm_green_gain_par2 : // unsigned , default = 255 par2 for green gain, dft =
7: 0	R/W	16	reg_nr4_cm_green_gain_par3 : // unsigned , default = 16 par3 for green gain, dft =

**Table 9-1042 NR4\_MCNR\_GREEN\_GAIN\_PAR1 0x2dcf**

Bit(s)	R/W	Default	Description
23:16	R/W	16	reg_nr4_cm_green_gain_par4 : // unsigned , default = 16 par4 for green gain, dft =
15: 8	R/W	128	reg_nr4_cm_green_gain_par5 : // unsigned , default = 128 par5 for green gain, dft =
7: 0	R/W	0	reg_nr4_cm_green_gain_par6 : // unsigned , default = 0 par6 for green gain, dft =

**Table 9-1043 NR4\_MCNR\_GREEN\_CLIP0 0x2dd0**

Bit(s)	R/W	Default	Description
23:16	R/W	40	reg_nr4_cm_green_luma_min : // unsigned , default = 40 luma min for green color matching, dft =
7: 0	R/W	160	reg_nr4_cm_green_luma_max : // unsigned , default = 160 luma max for green color matching, dft =

**Table 9-1044 NR4\_MCNR\_GREEN\_CLIP2 0x2dd1**

Bit(s)	R/W	Default	Description
31:24	R/W	4	reg_nr4_cm_green_sat_min : // unsigned , default = 4 saturation min for green color matching, dft =
23:16	R/W	255	reg_nr4_cm_green_sat_max : // unsigned , default = 255 saturation max for green color matching, dft =
15: 8	R/W	0	reg_nr4_cm_green_var_min : // unsigned , default = 0 variation min for green color matching, dft =
7: 0	R/W	12	reg_nr4_cm_green_var_max : // unsigned , default = 12 variation max for green color matching, dft =

**Table 9-1045 NR4\_MCNR\_SKIN\_CENT 0x2dd2**

Bit(s)	R/W	Default	Description
23:16	R/W	112	reg_nr4_cm_skin_centr : // unsigned , default = 112 x coordinate of center of skin tone, dft =
7: 0	R/W	149	reg_nr4_cm_skin_cent_y : // unsigned , default = 149 y coordinate of center of skin tone, dft =

**Table 9-1046 NR4\_MCNR\_SKIN\_GAIN\_PAR0 0x2dd3**

Bit(s)	R/W	Default	Description
31:24	R/W	20	reg_nr4_cm_skin_gain_par0 : // unsigned , default = 20 par0 for skin gain, dft =
23:16	R/W	255	reg_nr4_cm_skin_gain_par1 : // unsigned , default = 255 par1 for skin gain, dft =
15: 8	R/W	255	reg_nr4_cm_skin_gain_par2 : // unsigned , default = 255 par2 for skin gain, dft =
7: 0	R/W	8	reg_nr4_cm_skin_gain_par3 : // unsigned , default = 8 par3 for skin gain, dft =

**Table 9-1047 NR4\_MCNR\_SKIN\_GAIN\_PAR1 0x2dd4**

Bit(s)	R/W	Default	Description
23:16	R/W	8	reg_nr4_cm_skin_gain_par4 : // unsigned , default = 8 par4 for skin gain, dft =
15: 8	R/W	128	reg_nr4_cm_skin_gain_par5 : // unsigned , default = 128 par5 for skin gain, dft =
7: 0	R/W	0	reg_nr4_cm_skin_gain_par6 : // unsigned , default = 0 par6 for skin gain, dft =

**Table 9-1048 NR4\_MCNR\_SKIN\_CLIP0 0x2dd5**

Bit(s)	R/W	Default	Description
23:16	R/W	40	reg_nr4_cm_skin_luma_min : // unsigned , default = 40 luma min for skin color matching, dft =
7: 0	R/W	180	reg_nr4_cm_skin_luma_max : // unsigned , default = 180 luma max for skin color matching, dft =

**Table 9-1049 NR4\_MCNR\_SKIN\_CLIP1 0x2dd6**

Bit(s)	R/W	Default	Description
31:24	R/W	5	reg_nr4_cm_skin_sat_min : // unsigned , default = 5 saturation min for skin color matching, dft =
23:16	R/W	255	reg_nr4_cm_skin_sat_max : // unsigned , default = 255 saturation max for skin color matching, dft =
15: 8	R/W	0	reg_nr4_cm_skin_var_min : // unsigned , default = 0 variation min for skin color matching, dft =
7: 0	R/W	12	reg_nr4_cm_skin_var_max : // unsigned , default = 12 variation max for skin color matching, dft =

**Table 9-1050 NR4\_MCNR\_ALP1\_GLB\_CTRL 0x2dd7**

Bit(s)	R/W	Default	Description
31	R/W	0	reg_nr4_alp1_glb_gain_en : // unsigned , default = 0 alp1 adjust by global gain, dft = 1
30:28	R/W	6	reg_nr4_alp1_glb_gain_lsft : // unsigned , default = 6 alp1 left shift before combine with global gain
27	R/W	1	reg_nr4_bet0_glb_gain_en : // unsigned , default = 1 bet0 adjust by global gain, dft = 1

Bit(s)	R/W	Default	Description
26:24	R/W	6	reg_nr4_bet0_glb_gain_lsft : // unsigned , default = 6 bet1 left shift before combine with global gain
23	R/W	0	reg_nr4_bet1_glb_gain_en : // unsigned , default = 0 bet1 adjust by global gain, dft = 0
22:20	R/W	6	reg_nr4_bet1_glb_gain_lsft : // unsigned , default = 6 bet1 left shift before combine with global gain
19	R/W	1	reg_nr4_bet2_glb_gain_en : // unsigned , default = 1 bet2 adjust by global gain, dft = 1
18:16	R/W	6	reg_nr4_bet2_glb_gain_lsft : // unsigned , default = 6 bet2 left shift before combine with global gain
15	R/W	1	reg_nr4_alp1_ac_en : // unsigned , default = 1 alp1 adjust by ac, dft = 1
14:12	R/W	5	reg_nr4_alp1_ac_lsft : // unsigned , default = 5 alp1 left shift before combine with ac
11	R/W	0	reg_nr4_bet0_ac_en : // unsigned , default = 0 bet0 adjust by ac, dft = 1
10: 8	R/W	5	reg_nr4_bet0_ac_lsft : // unsigned , default = 5 bet0 left shift before combine with ac
7	R/W	0	reg_nr4_bet1_ac_en : // unsigned , default = 0 bet1 adjust by ac, dft = 1
6: 4	R/W	5	reg_nr4_bet1_ac_lsft : // unsigned , default = 5 bet1 left shift before combine with ac
3	R/W	0	reg_nr4_bet2_ac_en : // unsigned , default = 0 bet2 adjust by ac, dft = 1
2: 0	R/W	5	reg_nr4_bet2_ac_lsft : // unsigned , default = 5 bet2 left shift before combine with ac

Table 9-1051 NR4\_MCNR\_DC2NORM\_LUT0 0x2dd8

Bit(s)	R/W	Default	Description
28:24	R/W	16	reg_nr4_dc2norm_lut0 : // unsigned , default = 16 normal 0~16, dc to norm for alpha adjust, dft =
20:16	R/W	16	reg_nr4_dc2norm_lut1 : // unsigned , default = 16 normal 0~16, dc to norm for alpha adjust, dft =
12: 8	R/W	16	reg_nr4_dc2norm_lut2 : // unsigned , default = 16 normal 0~16, dc to norm for alpha adjust, dft =
4: 0	R/W	16	reg_nr4_dc2norm_lut3 : // unsigned , default = 16 normal 0~16, dc to norm for alpha adjust, dft =

Table 9-1052 NR4\_MCNR\_DC2NORM\_LUT1 0x2dd9

Bit(s)	R/W	Default	Description
28:24	R/W	16	reg_nr4_dc2norm_lut4 : // unsigned , default = 16 normal 0~16, dc to norm for alpha adjust, dft =
20:16	R/W	16	reg_nr4_dc2norm_lut5 : // unsigned , default = 16 normal 0~16, dc to norm for alpha adjust, dft =
12: 8	R/W	16	reg_nr4_dc2norm_lut6 : // unsigned , default = 16 normal 0~16, dc to norm for alpha adjust, dft =
4: 0	R/W	12	reg_nr4_dc2norm_lut7 : // unsigned , default = 12 normal 0~16, dc to norm for alpha adjust, dft =

**Table 9-1053 NR4\_MCNR\_DC2NORM\_LUT2 0x2dda**

Bit(s)	R/W	Default	Description
4: 0	R/W	8	reg_nr4_dc2norm_lut8 : // unsigned , default = 8 normal 0~16, dc to norm for alpha adjust, dft =

**Table 9-1054 NR4\_MCNR\_AC2NORM\_LUT0 0x2ddb**

Bit(s)	R/W	Default	Description
28:24	R/W	2	reg_nr4_ac2norm_lut0 : // unsigned , default = 2 normal 0~16, ac to norm for alpha adjust, dft =
20:16	R/W	16	reg_nr4_ac2norm_lut1 : // unsigned , default = 16 normal 0~16, ac to norm for alpha adjust, dft =
12: 8	R/W	16	reg_nr4_ac2norm_lut2 : // unsigned , default = 16 normal 0~16, ac to norm for alpha adjust, dft =
4: 0	R/W	12	reg_nr4_ac2norm_lut3 : // unsigned , default = 12 normal 0~16, ac to norm for alpha adjust, dft =

**Table 9-1055 NR4\_MCNR\_AC2NORM\_LUT1 0x2ddc**

Bit(s)	R/W	Default	Description
28:24	R/W	4	reg_nr4_ac2norm_lut4 : // unsigned , default = 4 normal 0~16, ac to norm for alpha adjust, dft =
20:16	R/W	2	reg_nr4_ac2norm_lut5 : // unsigned , default = 2 normal 0~16, ac to norm for alpha adjust, dft =
12: 8	R/W	1	reg_nr4_ac2norm_lut6 : // unsigned , default = 1 normal 0~16, ac to norm for alpha adjust, dft =
4: 0	R/W	1	reg_nr4_ac2norm_lut7 : // unsigned , default = 1 normal 0~16, ac to norm for alpha adjust, dft =

**Table 9-1056 NR4\_MCNR\_AC2NORM\_LUT2 0x2ddd**

Bit(s)	R/W	Default	Description
4: 0	R/W	1	reg_nr4_ac2norm_lut8 : // unsigned , default = 1 normal 0~16, ac to norm for alpha adjust, dft =

**Table 9-1057 NR4\_MCNR\_SAD2ALP0\_LUT0 0x2dde**

Bit(s)	R/W	Default	Description
31:24	R/W	255	reg_nr4_sad2alp0_lut0 : // unsigned , default = 255 sad to alpha0 for temporal pixel value, dft = 255
23:16	R/W	252	reg_nr4_sad2alp0_lut1 : // unsigned , default = 252 sad to alpha0 for temporal pixel value, dft = 252

Bit(s)	R/W	Default	Description
15: 8	R/W	249	reg_nr4_sad2alp0_lut2 : // unsigned , default = 249 sad to alpha0 for temporal pixel value, dft = 249
7: 0	R/W	235	reg_nr4_sad2alp0_lut3 : // unsigned , default = 235 sad to alpha0 for temporal pixel value, dft = 70

Table 9-1058 NR4\_MCNR\_SAD2ALP0\_LUT1 0x2ddf

Bit(s)	R/W	Default	Description
31:24	R/W	185	reg_nr4_sad2alp0_lut4 : // unsigned , default = 185 sad to alpha0 for temporal pixel value, dft = 12
23:16	R/W	70	reg_nr4_sad2alp0_lut5 : // unsigned , default = 70 sad to alpha0 for temporal pixel value, dft = 1
15: 8	R/W	14	reg_nr4_sad2alp0_lut6 : // unsigned , default = 14 sad to alpha0 for temporal pixel value, dft = 0
7: 0	R/W	1	reg_nr4_sad2alp0_lut7 : // unsigned , default = 1 sad to alpha0 for temporal pixel value, dft = 0

Table 9-1059 NR4\_MCNR\_SAD2ALP0\_LUT2 0x2de0

Bit(s)	R/W	Default	Description
31:24	R/W	0	reg_nr4_sad2alp0_lut8 : // unsigned , default = 0 sad to alpha0 for temporal pixel value, dft = 0
23:16	R/W	0	reg_nr4_sad2alp0_lut9 : // unsigned , default = 0 sad to alpha0 for temporal pixel value, dft = 0
15: 8	R/W	0	reg_nr4_sad2alp0_lut10 : // unsigned , default = 0 sad to alpha0 for temporal pixel value, dft = 0
7: 0	R/W	0	reg_nr4_sad2alp0_lut11 : // unsigned , default = 0 sad to alpha0 for temporal pixel value, dft = 0

Table 9-1060 NR4\_MCNR\_SAD2ALP0\_LUT3 0x2de1

Bit(s)	R/W	Default	Description
31:24	R/W	0	reg_nr4_sad2alp0_lut12 : // unsigned , default = 0 sad to alpha0 for temporal pixel value, dft = 0
23:16	R/W	0	reg_nr4_sad2alp0_lut13 : // unsigned , default = 0 sad to alpha0 for temporal pixel value, dft = 0
15: 8	R/W	0	reg_nr4_sad2alp0_lut14 : // unsigned , default = 0 sad to alpha0 for temporal pixel value, dft = 0
7: 0	R/W	0	reg_nr4_sad2alp0_lut15 : // unsigned , default = 0 sad to alpha0 for temporal pixel value, dft = 0



**Table 9-1061 NR4\_MCNR\_SAD2ALP1\_LUT0 0x2de2**

Bit(s)	R/W	Default	Description
31:24	R/W	192	reg_nr4_sad2alp1_lut0 : // unsigned , default = 192 sad to alpha1 for temporal blending, dft = 128
23:16	R/W	160	reg_nr4_sad2alp1_lut1 : // unsigned , default = 160 sad to alpha1 for temporal blending, dft = 128
15: 8	R/W	128	reg_nr4_sad2alp1_lut2 : // unsigned , default = 128 sad to alpha1 for temporal blending, dft = 128
7: 0	R/W	96	reg_nr4_sad2alp1_lut3 : // unsigned , default = 96 sad to alpha1 for temporal blending, dft = 64

**Table 9-1062 NR4\_MCNR\_SAD2ALP1\_LUT1 0x2de3**

Bit(s)	R/W	Default	Description
31:24	R/W	64	reg_nr4_sad2alp1_lut4 : // unsigned , default = 64 sad to alpha1 for temporal blending, dft = 64
23:16	R/W	32	reg_nr4_sad2alp1_lut5 : // unsigned , default = 32 sad to alpha1 for temporal blending, dft = 128
15: 8	R/W	16	reg_nr4_sad2alp1_lut6 : // unsigned , default = 16 sad to alpha1 for temporal blending, dft = 255
7: 0	R/W	8	reg_nr4_sad2alp1_lut7 : // unsigned , default = 8 sad to alpha1 for temporal blending, dft = 255

**Table 9-1063 NR4\_MCNR\_SAD2ALP1\_LUT2 0x2de4**

Bit(s)	R/W	Default	Description
31:24	R/W	4	reg_nr4_sad2alp1_lut8 : // unsigned , default = 4 sad to alpha1 for temporal blending, dft = 255
23:16	R/W	0	reg_nr4_sad2alp1_lut9 : // unsigned , default = 0 sad to alpha1 for temporal blending, dft = 255
15: 8	R/W	16	reg_nr4_sad2alp1_lut10 : // unsigned , default = 16 sad to alpha1 for temporal blending, dft = 255
7: 0	R/W	64	reg_nr4_sad2alp1_lut11 : // unsigned , default = 64 sad to alpha1 for temporal blending, dft = 255

**Table 9-1064 NR4\_MCNR\_SAD2ALP1\_LUT3 0x2de5**

Bit(s)	R/W	Default	Description
31:24	R/W	96	reg_nr4_sad2alp1_lut12 : // unsigned , default = 96 sad to alpha1 for temporal blending, dft = 255
23:16	R/W	224	reg_nr4_sad2alp1_lut13 : // unsigned , default = 224 sad to alpha1 for temporal blending, dft = 255
15: 8	R/W	255	reg_nr4_sad2alp1_lut14 : // unsigned , default = 255 sad to alpha1 for temporal blending, dft = 255
7: 0	R/W	255	reg_nr4_sad2alp1_lut15 : // unsigned , default = 255 sad to alpha1 for temporal blending, dft = 255

**Table 9-1065 NR4\_MCNR\_SAD2BET0\_LUT0 0x2de6**

Bit(s)	R/W	Default	Description
31:24	R/W	0	reg_nr4_sad2bet0_lut0 : // unsigned , default = 0 sad to beta0 for tnr and mcnr blending, dft = 0
23:16	R/W	2	reg_nr4_sad2bet0_lut1 : // unsigned , default = 2 sad to beta0 for tnr and mcnr blending, dft = 2
15: 8	R/W	4	reg_nr4_sad2bet0_lut2 : // unsigned , default = 4 sad to beta0 for tnr and mcnr blending, dft = 4
7: 0	R/W	8	reg_nr4_sad2bet0_lut3 : // unsigned , default = 8 sad to beta0 for tnr and mcnr blending, dft = 8

**Table 9-1066 NR4\_MCNR\_SAD2BET0\_LUT1 0x2de7**

Bit(s)	R/W	Default	Description
31:24	R/W	16	reg_nr4_sad2bet0_lut4 : // unsigned , default = 16 sad to beta0 for tnr and mcnr blending, dft = 16
23:16	R/W	32	reg_nr4_sad2bet0_lut5 : // unsigned , default = 32 sad to beta0 for tnr and mcnr blending, dft = 32
15: 8	R/W	48	reg_nr4_sad2bet0_lut6 : // unsigned , default = 48 sad to beta0 for tnr and mcnr blending, dft = 48
7: 0	R/W	64	reg_nr4_sad2bet0_lut7 : // unsigned , default = 64 sad to beta0 for tnr and mcnr blending, dft = 64

**Table 9-1067 NR4\_MCNR\_SAD2BET0\_LUT2 0x2de8**

Bit(s)	R/W	Default	Description
31:24	R/W	80	reg_nr4_sad2bet0_lut8 : // unsigned , default = 80 sad to beta0 for tnr and mcnr blending, dft = 80
23:16	R/W	96	reg_nr4_sad2bet0_lut9 : // unsigned , default = 96 sad to beta0 for tnr and mcnr blending, dft = 96
15: 8	R/W	112	reg_nr4_sad2bet0_lut10 : // unsigned , default = 112 sad to beta0 for tnr and mcnr blending, dft = 112
7: 0	R/W	128	reg_nr4_sad2bet0_lut11 : // unsigned , default = 128 sad to beta0 for tnr and mcnr blending, dft = 128

**Table 9-1068 NR4\_MCNR\_SAD2BET0\_LUT3 0x2de9**

Bit(s)	R/W	Default	Description
31:24	R/W	196	reg_nr4_sad2bet0_lut12 : // unsigned , default = 196 sad to beta0 for tnr and mcnr blending, dft = 160
23:16	R/W	224	reg_nr4_sad2bet0_lut13 : // unsigned , default = 224 sad to beta0 for tnr and mcnr blending, dft = 192
15: 8	R/W	255	reg_nr4_sad2bet0_lut14 : // unsigned , default = 255 sad to beta0 for tnr and mcnr blending, dft = 224
7: 0	R/W	255	reg_nr4_sad2bet0_lut15 : // unsigned , default = 255 sad to beta0 for tnr and mcnr blending, dft = 255

**Table 9-1069 NR4\_MCNR\_SAD2BET1\_LUT0 0x2dea**

Bit(s)	R/W	Default	Description
31:24	R/W	0	reg_nr4_sad2bet1_lut0 : // unsigned , default = 0 sad to beta1 for degghost blending, dft = 0
23:16	R/W	2	reg_nr4_sad2bet1_lut1 : // unsigned , default = 2 sad to beta1 for degghost blending, dft = 2
15: 8	R/W	4	reg_nr4_sad2bet1_lut2 : // unsigned , default = 4 sad to beta1 for degghost blending, dft = 4
7: 0	R/W	8	reg_nr4_sad2bet1_lut3 : // unsigned , default = 8 sad to beta1 for degghost blending, dft = 8

**Table 9-1070 NR4\_MCNR\_SAD2BET1\_LUT1 0x2deb**

Bit(s)	R/W	Default	Description
31:24	R/W	16	reg_nr4_sad2bet1_lut4 : // unsigned , default = 16 sad to beta1 for degghost blending, dft = 16
23:16	R/W	32	reg_nr4_sad2bet1_lut5 : // unsigned , default = 32 sad to beta1 for degghost blending, dft = 32
15: 8	R/W	48	reg_nr4_sad2bet1_lut6 : // unsigned , default = 48 sad to beta1 for degghost blending, dft = 48
7: 0	R/W	64	reg_nr4_sad2bet1_lut7 : // unsigned , default = 64 sad to beta1 for degghost blending, dft = 64

**Table 9-1071 NR4\_MCNR\_SAD2BET1\_LUT2 0x2dec**

Bit(s)	R/W	Default	Description
31:24	R/W	80	reg_nr4_sad2bet1_lut8 : // unsigned , default = 80 sad to beta1 for degghost blending, dft = 80
23:16	R/W	96	reg_nr4_sad2bet1_lut9 : // unsigned , default = 96 sad to beta1 for degghost blending, dft = 96
15: 8	R/W	112	reg_nr4_sad2bet1_lut10 : // unsigned , default = 112 sad to beta1 for degghost blending, dft = 112
7: 0	R/W	128	reg_nr4_sad2bet1_lut11 : // unsigned , default = 128 sad to beta1 for degghost blending, dft = 128

**Table 9-1072 NR4\_MCNR\_SAD2BET1\_LUT3 0x2ded**

Bit(s)	R/W	Default	Description
31:24	R/W	160	reg_nr4_sad2bet1_lut12 : // unsigned , default = 160 sad to beta1 for degghost blending, dft = 160
23:16	R/W	192	reg_nr4_sad2bet1_lut13 : // unsigned , default = 192 sad to beta1 for degghost blending, dft = 192
15: 8	R/W	224	reg_nr4_sad2bet1_lut14 : // unsigned , default = 224 sad to beta1 for degghost blending, dft = 224
7: 0	R/W	255	reg_nr4_sad2bet1_lut15 : // unsigned , default = 255 sad to beta1 for degghost blending, dft = 255

**Table 9-1073 NR4\_MCNR\_SAD2BET2\_LUT0 0x2dee**

Bit(s)	R/W	Default	Description
31:24	R/W	0	reg_nr4_sad2bet2_lut0 : // unsigned , default = 0 sad to beta2 for snr and mcnr blending, dft = 0
23:16	R/W	1	reg_nr4_sad2bet2_lut1 : // unsigned , default = 1 sad to beta2 for snr and mcnr blending, dft = 2
15: 8	R/W	2	reg_nr4_sad2bet2_lut2 : // unsigned , default = 2 sad to beta2 for snr and mcnr blending, dft = 4
7: 0	R/W	4	reg_nr4_sad2bet2_lut3 : // unsigned , default = 4 sad to beta2 for snr and mcnr blending, dft = 8

**Table 9-1074 NR4\_MCNR\_SAD2BET2\_LUT1 0x2def**

Bit(s)	R/W	Default	Description
31:24	R/W	8	reg_nr4_sad2bet2_lut4 : // unsigned , default = 8 sad to beta2 for snr and mcnr blending, dft = 16
23:16	R/W	16	reg_nr4_sad2bet2_lut5 : // unsigned , default = 16 sad to beta2 for snr and mcnr blending, dft = 32
15: 8	R/W	32	reg_nr4_sad2bet2_lut6 : // unsigned , default = 32 sad to beta2 for snr and mcnr blending, dft = 48
7: 0	R/W	48	reg_nr4_sad2bet2_lut7 : // unsigned , default = 48 sad to beta2 for snr and mcnr blending, dft = 64

**Table 9-1075 NR4\_MCNR\_SAD2BET2\_LUT2 0x2df0**

Bit(s)	R/W	Default	Description
31:24	R/W	64	reg_nr4_sad2bet2_lut8 : // unsigned , default = 64 sad to beta2 for snr and mcnr blending, dft = 80
23:16	R/W	80	reg_nr4_sad2bet2_lut9 : // unsigned , default = 80 sad to beta2 for snr and mcnr blending, dft = 96
15: 8	R/W	96	reg_nr4_sad2bet2_lut10 : // unsigned , default = 96 sad to beta2 for snr and mcnr blending, dft = 112
7: 0	R/W	112	reg_nr4_sad2bet2_lut11 : // unsigned , default = 112 sad to beta2 for snr and mcnr blending, dft = 128

**Table 9-1076 NR4\_MCNR\_SAD2BET2\_LUT3 0x2df1**

Bit(s)	R/W	Default	Description
31:24	R/W	128	reg_nr4_sad2bet2_lut12 : // unsigned , default = 128 sad to beta2 for snr and mcnr blending, dft = 160
23:16	R/W	160	reg_nr4_sad2bet2_lut13 : // unsigned , default = 160 sad to beta2 for snr and mcnr blending, dft = 192
15: 8	R/W	224	reg_nr4_sad2bet2_lut14 : // unsigned , default = 224 sad to beta2 for snr and mcnr blending, dft = 224
7: 0	R/W	255	reg_nr4_sad2bet2_lut15 : // unsigned , default = 255 sad to beta2 for snr and mcnr blending, dft = 255

**Table 9-1077 NR4\_MCNR\_RO\_U\_SUM 0x2df2**

Bit(s)	R/W	Default	Description
31:0	R.O	0	ro_nr4_u_sum : // unsigned , default = 0 sum of U of current field/frame

**Table 9-1078 NR4\_MCNR\_RO\_V\_SUM 0x2df3**

Bit(s)	R/W	Default	Description
31:0	R.O	0	ro_nr4_v_sum : // unsigned , default = 0 sum of V of current field/frame

**Table 9-1079 NR4\_MCNR\_RO\_GRDU\_SUM 0x2df4**

Bit(s)	R/W	Default	Description
31:0	R.O	0	ro_nr4_grdu_sum : // unsigned , default = 0 sum of gradient U of current field/frame

**Table 9-1080 NR4\_MCNR\_RO\_GRDV\_SUM 0x2df5**

Bit(s)	R/W	Default	Description
31:0	R.O	0	ro_nr4_grdv_sum : // unsigned , default = 0 sum of gradient V of current field/frame

**Table 9-1081 NR4\_TOP\_CTRL 0x2dff**

Bit(s)	R/W	Default	Description
31:20	R/W	0	reg_gclk_ctrl : // unsigned , default = 0
18	R/W	1	reg_nr4_mcnr_en : // unsigned , default = 1 ncnr enable or bypass, dft = 1
17	R/W	1	reg_nr2_en : // unsigned , default = 1 nr2 enable, dft = 1
16	R/W	1	reg_nr4_en : // unsigned , default = 1 nr4 enable, dft = 1
15	R/W	1	reg_nr2_proc_en : // unsigned , default = 1
14	R/W	1	reg_det3d_en : // unsigned , default = 1
13	R/W	1	di_polar_en : // unsigned , default = 1 do does not have in C
12	R/W	0	reg_cfr_enable : // unsigned , default = 0 0-disable; 1:enable
11:9	R/W	7	reg_3dnr_enable_l : // unsigned , default = 7 b0: Y b1:U b2:V
8:6	R/W	7	reg_3dnr_enable_r : // unsigned , default = 7 b0: Y b1:U b2:V
5	R/W	1	reg_nr4_lbuf_ctrl : // unsigned , default = 1 line buf ctrl for nr4: 0, 3lines, 1, 5lines, dft = 1
4	R/W	0	reg_nr4_snr2_en : // unsigned , default = 0 snr2 enable, 0: use old snr, 1: use new snr2, dft = 1
3	R/W	1	reg_nr4_scene_change_en : // unsigned , default = 1 enable scene change proc. dft = 1
2	R/W	1	nr2_sw_en : // unsigned , default = 1 do does not have in C
0	R/W	0	reg_nr4_scene_change_flg : // unsigned , default = 0 flags for scene change, dft = 0

Table 9-1082 NR4\_MCNR\_SAD\_GAIN 0x3700

Bit(s)	R/W	Default	Description
24	R/W	0	reg_nr4_bld12vs3_usemaxsad : // unsigned , default = 0 use minsad/maxsad instead of minsad/avgsad to decision if it was texture or flat region, 1: use minsad/maxsad
23:16	R/W	64	reg_nr4_bld12vs3_rate_gain : // unsigned , default = 64 gain to minsad/maxsad or minsad/avgsad before LUT, 64 normalized as "1"
15: 8	R/W	32	reg_nr4_bld1vs2_rate_gain : // unsigned , default = 32 gain to minsad/maxsad or minsad/avgsad before the LUT, 64 normalized as "1"
7: 0	R/W	64	reg_nr4_coefblt_gain : // unsigned , default = 64 gain to final coefblt, normalized 64 as "1"

Table 9-1083 NR4\_MCNR\_LPF\_CTRL 0x3701

Bit(s)	R/W	Default	Description
30:22	R/W	0	reg_nr4_prefilt_alpofst : // signed , default = 0 pre filter alpha ofst
21:16	R/W	16	reg_nr4_prefilt_alpgain : // unsigned , default = 16 pre filter alpha gain
15:14	R/W	3	reg_nr4_prefilt_alpsel : // unsigned , default = 3 pre filter alpha selection for adaptive blending, 0: mv pointed sad, 1: weighted mv pointed sad, 2or3: coefblt
13: 8	R/W	8	reg_nr4_avgsad_gain : // unsigned , default = 8 gain for avg sad before luts
6	R/W	1	reg_nr4_maxsad_mod : // unsigned , default = 1 max sad select mode, 0: mx2_sad, 1: max sad
5	R/W	1	reg_nr4_minsad_mod : // unsigned , default = 1 min sad select mode, 0: sad with min err, 1: min sad
4	R/W	1	reg_nr4_minmaxsad_lpf : // unsigned , default = 1 mode of lpf for minmaxsad, 0: no LPF, 1: [1 2 1]/4
3	R/W	1	reg_nr4_avgsad_lpf : // unsigned , default = 1 mode of lpf for avgsad, 0: no LPF, 1: [1 2 1]/4
2	R/W	1	reg_nr4_minavgsad_ratio_lpf : // unsigned , default = 1 mode of lpf for minsad/avgsad and zmvvad/avgsad, 0: no LPF, 1: [1 2 1]/4
1	R/W	1	reg_nr4_bldvs_lut_lpf : // unsigned , default = 1 mode of lpf for bld12vs3 and bld1vs2 LUT results, 0: no LPF, 1: [1 2 1]/4
0	R/W	1	reg_nr4_final_coef_lpf : // unsigned , default = 1 mode of lpf for final coef_bl_t_blend123, 0: no LPF, 1: [1 2 1]/4

Table 9-1084 NR4\_MCNR\_BLD\_VS3LUT0 0x3702

Bit(s)	R/W	Default	Description
29:24	R/W	0	reg_nr4_bld12vs3_lut0 : // unsigned , default = 0
21:16	R/W	8	reg_nr4_bld12vs3_lut1 : // unsigned , default = 8
13: 8	R/W	10	reg_nr4_bld12vs3_lut2 : // unsigned , default = 10
5: 0	R/W	11	reg_nr4_bld12vs3_lut3 : // unsigned , default = 11

**Table 9-1085 NR4\_MCNR\_BLD\_VS3LUT1 0x3703**

Bit(s)	R/W	Default	Description
29:24	R/W	12	reg_nr4_bld12vs3_lut4 : // unsigned , default = 12
21:16	R/W	14	reg_nr4_bld12vs3_lut5 : // unsigned , default = 14
13: 8	R/W	16	reg_nr4_bld12vs3_lut6 : // unsigned , default = 16
5: 0	R/W	24	reg_nr4_bld12vs3_lut7 : // unsigned , default = 24

**Table 9-1086 NR4\_MCNR\_BLD\_VS3LUT2 0x3704**

Bit(s)	R/W	Default	Description
29:24	R/W	50	reg_nr4_bld12vs3_lut8 : // unsigned , default = 50
21:16	R/W	58	reg_nr4_bld12vs3_lut9 : // unsigned , default = 58
13: 8	R/W	63	reg_nr4_bld12vs3_lut10 : // unsigned , default = 63
5: 0	R/W	63	reg_nr4_bld12vs3_lut11 : // unsigned , default = 63

**Table 9-1087 NR4\_MCNR\_BLD\_VS2LUT0 0x3705**

Bit(s)	R/W	Default	Description
29:24	R/W	63	reg_nr4_bld1vs2_lut0 : // unsigned , default = 63
21:16	R/W	32	reg_nr4_bld1vs2_lut1 : // unsigned , default = 32
13: 8	R/W	16	reg_nr4_bld1vs2_lut2 : // unsigned , default = 16
5: 0	R/W	8	reg_nr4_bld1vs2_lut3 : // unsigned , default = 8

**Table 9-1088 NR4\_MCNR\_BLD\_VS2LUT1 0x3706**

Bit(s)	R/W	Default	Description
29:24	R/W	4	reg_nr4_bld1vs2_lut4 : // unsigned , default = 4
21:16	R/W	2	reg_nr4_bld1vs2_lut5 : // unsigned , default = 2
13: 8	R/W	1	reg_nr4_bld1vs2_lut6 : // unsigned , default = 1
5: 0	R/W	0	reg_nr4_bld1vs2_lut7 : // unsigned , default = 0

**Table 9-1089 NR4\_COEFBLT\_LUT10 0x3707**

Bit(s)	R/W	Default	Description
31:24	R/W	0x0	reg_nr4_coefblt_lut10 : // signed , default = -128
23:16	R/W	0x0	reg_nr4_coefblt_lut11 : // signed , default = -128
15: 8	R/W	0x0	reg_nr4_coefblt_lut12 : // signed , default = -126
7: 0	R/W	0x0	reg_nr4_coefblt_lut13 : // signed , default = -124

**Table 9-1090 NR4\_COEFBLT\_LUT11 0x3708**

Bit(s)	R/W	Default	Description
31:24	R/W	0x0	reg_nr4_coefblt_lut14 : // signed , default = -120
23:16	R/W	0x0	reg_nr4_coefblt_lut15 : // signed , default = -110
15: 8	R/W	0x0	reg_nr4_coefblt_lut16 : // signed , default = -100
7: 0	R/W	0x0	reg_nr4_coefblt_lut17 : // signed , default = -90

**Table 9-1091 NR4\_COEFBLT\_LUT12 0x3709**

Bit(s)	R/W	Default	Description
31:24	R/W	0x0	reg_nr4_coefblt_lut18 : // signed , default = -56
23:16	R/W	0x0	reg_nr4_coefblt_lut19 : // signed , default = -32
15: 8	R/W	0x0	reg_nr4_coefblt_lut110 : // signed , default = -64
7: 0	R/W	0x0	reg_nr4_coefblt_lut111 : // signed , default = -128

**Table 9-1092 NR4\_COEFBLT\_LUT20 0x370a**

Bit(s)	R/W	Default	Description
31:24	R/W	0x0	reg_nr4_coefblt_lut20 : // signed , default = -128
23:16	R/W	0x0	reg_nr4_coefblt_lut21 : // signed , default = -120
15: 8	R/W	0x0	reg_nr4_coefblt_lut22 : // signed , default = -112
7: 0	R/W	0x0	reg_nr4_coefblt_lut23 : // signed , default = -104

**Table 9-1093 NR4\_COEFBLT\_LUT21 0x370b**

Bit(s)	R/W	Default	Description
31:24	R/W	0x0	reg_nr4_coefblt_lut24 : // signed , default = -96
23:16	R/W	0x0	reg_nr4_coefblt_lut25 : // signed , default = -88
15: 8	R/W	0x0	reg_nr4_coefblt_lut26 : // signed , default = -76
7: 0	R/W	0x0	reg_nr4_coefblt_lut27 : // signed , default = -64

**Table 9-1094 NR4\_COEFBLT\_LUT22 0x370c**

Bit(s)	R/W	Default	Description
31:24	R/W	0x0	reg_nr4_coefblt_lut28 : // signed , default = -48
23:16	R/W	0x0	reg_nr4_coefblt_lut29 : // signed , default = -32
15: 8	R/W	0x0	reg_nr4_coefblt_lut210 : // signed , default = -64
7: 0	R/W	0x0	reg_nr4_coefblt_lut211 : // signed , default = -108



**Table 9-1095 NR4\_COEFBLT\_LUT30 0x370d**

Bit(s)	R/W	Default	Description
31:24	R/W	8	reg_nr4_coefblt_lut30 : // signed , default = 8
23:16	R/W	16	reg_nr4_coefblt_lut31 : // signed , default = 16
15: 8	R/W	24	reg_nr4_coefblt_lut32 : // signed , default = 24
7: 0	R/W	30	reg_nr4_coefblt_lut33 : // signed , default = 30

**Table 9-1096 NR4\_COEFBLT\_LUT31 0x370e**

Bit(s)	R/W	Default	Description
31:24	R/W	36	reg_nr4_coefblt_lut34 : // signed , default = 36
23:16	R/W	48	reg_nr4_coefblt_lut35 : // signed , default = 48
15: 8	R/W	70	reg_nr4_coefblt_lut36 : // signed , default = 70
7: 0	R/W	96	reg_nr4_coefblt_lut37 : // signed , default = 96

**Table 9-1097 NR4\_COEFBLT\_LUT32 0x370f**

Bit(s)	R/W	Default	Description
31:24	R/W	120	reg_nr4_coefblt_lut38 : // signed , default = 120
23:16	R/W	64	reg_nr4_coefblt_lut39 : // signed , default = 64
15: 8	R/W	16	reg_nr4_coefblt_lut310 : // signed , default = 16
7: 0	R/W	0x0	reg_nr4_coefblt_lut311 : // signed , default = -8

**Table 9-1098 NR4\_COEFBLT\_CONV 0x3710**

Bit(s)	R/W	Default	Description
23:16	R/W	0	reg_nr4_coefblt_convmin : // unsigned , default = 0 minimum of coef. bilateral conversion
15: 8	R/W	255	reg_nr4_coefblt_convmax : // unsigned , default = 255 maximum of coef. bilateral conversion
7: 0	R/W	128	reg_nr4_coefblt_convmid : // unsigned , default = 128 value at midpoint of coef. bilateral conversion

**Table 9-1099 NR4\_DBGWIN\_YX0 0x3711**

Bit(s)	R/W	Default	Description
29:16	R/W	100	reg_nr4_dgbwin_yx0 : // unsigned , default = 100 ystart for debug window
13: 0	R/W	160	reg_nr4_dgbwin_yx1 : // unsigned , default = 160 yend for debug window

**Table 9-1100 NR4\_DBGWIN\_YX1 0x3712**

Bit(s)	R/W	Default	Description
29:16	R/W	200	reg_nr4_dgbwin_yx2 : // unsigned , default = 200 xstart for debug window
13: 0	R/W	300	reg_nr4_dgbwin_yx3 : // unsigned , default = 300 xend for debug window

**Table 9-1101 NR4\_NM\_X\_CFG 0x3713**

Bit(s)	R/W	Default	Description
29:16	R/W	8	reg_nr4_nm_xst : // unsigned , default = 8 start for noise meter statistic, dft = 8
13: 0	R/W	711	reg_nr4_nm_xed : // unsigned , default = 711 end for noise meter statistic, dft = HSIZE-8-1;

**Table 9-1102 NR4\_NM\_Y\_CFG 0x3714**

Bit(s)	R/W	Default	Description
29:16	R/W	8	reg_nr4_nm_yst : // unsigned , default = 8 start for noise meter statistic, dft = 8;
13: 0	R/W	231	reg_nr4_nm_yed : // unsigned , default = 231 end for noise meter statistic, dft = VSIZE-8-1;

**Table 9-1103 NR4\_NM\_SAD\_THD 0x3715**

Bit(s)	R/W	Default	Description
7: 0	R/W	255	reg_nr4_nm_sad_thd : // unsigned , default = 255 threshold for (flat region) sad count, dft = 4

**Table 9-1104 NR4\_MCNR\_BANDSPLIT\_PRAM 0x3716**

Bit(s)	R/W	Default	Description
4	R/W	1	reg_nr4_mc_use_bandsplit : // unsigned , default = 1 separate lp and us for mc IIR filter, 0: no BS used; 1: use BS
3	R/W	1	reg_nr4_mc_apply_on_lp : // unsigned , default = 1 use mcnr only on lowpass portion;
2	R/W	1	reg_nr4_mc_apply_on_us : // unsigned , default = 1 use mcnr only on lp complementary portion;
1: 0	R/W	1	reg_nr4_mc_zmvbs_use_adplpf : // unsigned , default = 1 use adaptive LPF for the zmv pointing data for MCNR, for abs(mvx)<th

**Table 9-1105 NR4\_MCNR\_ALP1\_SGN\_COR 0x3717**

Bit(s)	R/W	Default	Description
31:24	R/W	10	reg_nr4_mc_aph1_sgn_coring0 : // unsigned , default = 10 coring to cur-pre before do sgn decision
23:16	R/W	7	reg_nr4_mc_aph1_sgn_coring1 : // unsigned , default = 7 coring to cur-pre before do sgn decision

Bit(s)	R/W	Default	Description
15: 8	R/W	90	reg_nr4_mc_aph1_sgn_core_max0 : // unsigned , default = 90 maximum of coring, default = 30/15
7: 0	R/W	15	reg_nr4_mc_aph1_sgn_core_max1 : // unsigned , default = 15 maximum of coring, default = 30/15

Table 9-1106 NR4\_MCNR\_ALP1\_SGN\_PRAM 0x3718

Bit(s)	R/W	Default	Description
10	R/W	1	reg_nr4_mc_alp1_sgn_half : // unsigned , default = 1 half block sgn sum mode enable, 0: only use 3x5 whole block sum of sgns; 1: use max(sgn_3x5, sqrt(sgn_left+sgn_right))
9	R/W	1	reg_nr4_mc_alp1_sgn_frczmv : // unsigned , default = 1 force zmv to calculate the sign_sum;
8	R/W	1	reg_nr4_mc_alp1_sgnmvx_mode : // unsigned , default = 1 blend mode of sgnlut and mvxlut blend mode: 0: sgnlut+ mvxlut; 1: max(sgnlut, mvxlut), default = 1
7: 4	R/W	4	reg_nr4_mc_aph1_sgn_crate0 : // unsigned , default = 4 rate to var, norm to 16 as 1, default = 2
3: 0	R/W	2	reg_nr4_mc_aph1_sgn_crate1 : // unsigned , default = 2 rate to var, norm to 16 as 1, default = 2

Table 9-1107 NR4\_MCNR\_ALP1\_MVX\_LUT1 0x3719

Bit(s)	R/W	Default	Description
31:28	R/W	14	reg_nr4_mc_alp1_mv_x_luty3 : // unsigned , default = 14 alp1 of luma vas mvx (0~7), and alp1 vs mvy(0,1)
27:24	R/W	14	reg_nr4_mc_alp1_mv_x_lutc3 : // unsigned , default = 14 alp1 of chrm vas mvx (0~7), and alp1 vs mvy(0,1)
23:20	R/W	12	reg_nr4_mc_alp1_mv_x_luty2 : // unsigned , default = 12 alp1 of luma vas mvx (0~7), and alp1 vs mvy(0,1)
19:16	R/W	12	reg_nr4_mc_alp1_mv_x_lutc2 : // unsigned , default = 12 alp1 of chrm vas mvx (0~7), and alp1 vs mvy(0,1)
15:12	R/W	5	reg_nr4_mc_alp1_mv_x_luty1 : // unsigned , default = 5 alp1 of luma vas mvx (0~7), and alp1 vs mvy(0,1)
11: 8	R/W	5	reg_nr4_mc_alp1_mv_x_lutc1 : // unsigned , default = 5 alp1 of chrm vas mvx (0~7), and alp1 vs mvy(0,1)
7: 4	R/W	3	reg_nr4_mc_alp1_mv_x_luty0 : // unsigned , default = 3 alp1 of luma vas mvx (0~7), and alp1 vs mvy(0,1)
3: 0	R/W	3	reg_nr4_mc_alp1_mv_x_lutc0 : // unsigned , default = 3 alp1 of chrm vas mvx (0~7), and alp1 vs mvy(0,1)

Table 9-1108 NR4\_MCNR\_ALP1\_MVX\_LUT2 0x371a

Bit(s)	R/W	Default	Description
31:28	R/W	15	reg_nr4_mc_alp1_mv_x_luty7 : // unsigned , default = 15 alp1 of luma vas mvx (0~7), and alp1 vs mvy(0,1)
27:24	R/W	15	reg_nr4_mc_alp1_mv_x_lutc7 : // unsigned , default = 15 alp1 of chrm vas mvx (0~7), and alp1 vs mvy(0,1)

Bit(s)	R/W	Default	Description
23:20	R/W	15	reg_nr4_mc_alp1_mv_x_luty6 : // unsigned , default = 15 alp1 of luma vas mvx (0~7), and alp1 vs mv(0,1)
19:16	R/W	15	reg_nr4_mc_alp1_mv_x_lutc6 : // unsigned , default = 15 alp1 of chrm vas mvx (0~7), and alp1 vs mv(0,1)
15:12	R/W	15	reg_nr4_mc_alp1_mv_x_luty5 : // unsigned , default = 15 alp1 of luma vas mvx (0~7), and alp1 vs mv(0,1)
11: 8	R/W	15	reg_nr4_mc_alp1_mv_x_lutc5 : // unsigned , default = 15 alp1 of chrm vas mvx (0~7), and alp1 vs mv(0,1)
7: 4	R/W	15	reg_nr4_mc_alp1_mv_x_luty4 : // unsigned , default = 15 alp1 of luma vas mvx (0~7), and alp1 vs mv(0,1)
3: 0	R/W	15	reg_nr4_mc_alp1_mv_x_lutc4 : // unsigned , default = 15 alp1 of chrm vas mvx (0~7), and alp1 vs mv(0,1)

Table 9-1109 NR4\_MCNR\_ALP1\_MVX\_LUT3 0x371b

Bit(s)	R/W	Default	Description
7: 4	R/W	6	reg_nr4_mc_alp1_mv_x_luty8 : // unsigned , default = 6 alp1 of luma vas mvx (0~7), and alp1 vs mv(0,1)
3: 0	R/W	6	reg_nr4_mc_alp1_mv_x_lutc8 : // unsigned , default = 6 alp1 of chrm vas mvx (0~7), and alp1 vs mv(0,1)

Table 9-1110 NR4\_MCNR\_ALP1\_LP\_PRAM 0x371c

Bit(s)	R/W	Default	Description
17:16	R/W	1	reg_nr4_mc_alp1_lp_sel : // unsigned , default = 1 mode for alp1_lp for lp portion IIR, 0: apha1, 1:dc_dif vs ac analysis; 2: gain/ofst of alp1; 3: max of 1/2 results
15: 8	R/W	64	reg_nr4_mc_alp1_lp_gain : // unsigned , default = 64 gain to alp1 to get the alp1_lp = alp1*gain/32 + ofset, default =64;
7: 0	R/W	0	reg_nr4_mc_alp1_lp_ofst : // signed , default = 0 offset to alp1 to get the alp1_lp = alp1*gain/32 + ofset, default =10;

Table 9-1111 NR4\_MCNR\_ALP1\_SGN\_LUT1 0x371d

Bit(s)	R/W	Default	Description
31:28	R/W	3	reg_nr4_mc_alp1_sgn_lut0 : // unsigned , default = 3 alp1 vs x=abs sgn(cur-pre) , if x is small, less possibility of flat region move
27:24	R/W	3	reg_nr4_mc_alp1_sgn_lut1 : // unsigned , default = 3 alp1 vs x=abs sgn(cur-pre) , if x is small, less possibility of flat region move
23:20	R/W	3	reg_nr4_mc_alp1_sgn_lut2 : // unsigned , default = 3 alp1 vs x=abs sgn(cur-pre) , if x is small, less possibility of flat region move
19:16	R/W	4	reg_nr4_mc_alp1_sgn_lut3 : // unsigned , default = 4 alp1 vs x=abs sgn(cur-pre) , if x is small, less possibility of flat region move
15:12	R/W	5	reg_nr4_mc_alp1_sgn_lut4 : // unsigned , default = 5 alp1 vs x=abs sgn(cur-pre) , if x is small, less possibility of flat region move

Bit(s)	R/W	Default	Description
11: 8	R/W	6	reg_nr4_mc_alp1_sgn_lut5 : // unsigned , default = 6 alp1 vs x=abs sgn(cur-pre)), if x is small, less possibility of flat region move
7: 4	R/W	7	reg_nr4_mc_alp1_sgn_lut6 : // unsigned , default = 7 alp1 vs x=abs sgn(cur-pre)), if x is small, less possibility of flat region move
3: 0	R/W	8	reg_nr4_mc_alp1_sgn_lut7 : // unsigned , default = 8 alp1 vs x=abs sgn(cur-pre)), if x is small, less possibility of flat region move

Table 9-1112 NR4\_MCNR\_ALP1\_SGN\_LUT2 0x371e

Bit(s)	R/W	Default	Description
31:28	R/W	9	reg_nr4_mc_alp1_sgn_lut8 : // unsigned , default = 9 alp1 vs x=abs sgn(cur-pre)), if x is small, less possibility of flat region move
27:24	R/W	10	reg_nr4_mc_alp1_sgn_lut9 : // unsigned , default = 10 alp1 vs x=abs sgn(cur-pre)), if x is small, less possibility of flat region move
23:20	R/W	11	reg_nr4_mc_alp1_sgn_lut10 : // unsigned , default = 11 alp1 vs x=abs sgn(cur-pre)), if x is small, less possibility of flat region move
19:16	R/W	12	reg_nr4_mc_alp1_sgn_lut11 : // unsigned , default = 12 alp1 vs x=abs sgn(cur-pre)), if x is small, less possibility of flat region move
15:12	R/W	13	reg_nr4_mc_alp1_sgn_lut12 : // unsigned , default = 13 alp1 vs x=abs sgn(cur-pre)), if x is small, less possibility of flat region move
11: 8	R/W	14	reg_nr4_mc_alp1_sgn_lut13 : // unsigned , default = 14 alp1 vs x=abs sgn(cur-pre)), if x is small, less possibility of flat region move
7: 4	R/W	15	reg_nr4_mc_alp1_sgn_lut14 : // unsigned , default = 15 alp1 vs x=abs sgn(cur-pre)), if x is small, less possibility of flat region move
3: 0	R/W	15	reg_nr4_mc_alp1_sgn_lut15 : // unsigned , default = 15 alp1 vs x=abs sgn(cur-pre)), if x is small, less possibility of flat region move

Table 9-1113 NR4\_RO\_NM\_SAD\_SUM 0x371f

Bit(s)	R/W	Default	Description
31: 0	R.O	0	ro_nr4_nm_sad_sum : // unsigned , default = 0 sum of sad, for scene change detection, in noise meter

Table 9-1114 NR4\_RO\_NM\_SAD\_CNT 0x3720

Bit(s)	R/W	Default	Description
31: 0	R.O	0	ro_nr4_nm_sad_cnt : // unsigned , default = 0 cnt of sad, for scene change detection, in noise meter

Table 9-1115 NR4\_RO\_NM\_VAR\_SUM 0x3721

Bit(s)	R/W	Default	Description
31: 0	R.O	0	ro_nr4_nm_var_sum : // unsigned , default = 0 sum of var, for noise level detection, in noise meter

**Table 9-1116 NR4\_RO\_NM\_VAR\_SCNT 0x3722**

Bit(s)	R/W	Default	Description
31: 0	R.O	0	ro_nr4_nm_var_cnt : // unsigned , default = 0 cnt of var, for noise level detection, in noise meter

**Table 9-1117 NR4\_RO\_NM\_VAR\_MIN\_MAX 0x3723**

Bit(s)	R/W	Default	Description
21:12	R.O	1023	ro_nr4_nm_min_var : // unsigned , default = 1023 min of var, for noise level detection, in noise meter
9: 0	R.O	0	ro_nr4_nm_max_var : // unsigned , default = 0 max of var, for noise level detection, in noise meter

**Table 9-1118 NR4\_RO\_NR4\_DBGPIX\_NUM 0x3724**

Bit(s)	R/W	Default	Description
27: 0	R.O	0	ro_nr4_dbgpix_num : // unsigned , default = 0 number of pixels statistic invoved (removed?)

**Table 9-1119 NR4\_RO\_NR4\_BLDVS2\_SUM 0x3725**

Bit(s)	R/W	Default	Description
31: 0	R.O	0	ro_nr4_bld1vs2_sum : // unsigned , default = 0 sum of blend_1vs2 with the debug window

**Table 9-1120 NR4\_BLDVS3\_SUM 0x3726**

Bit(s)	R/W	Default	Description
31: 0	R.O	0	ro_nr4_bld12vs3_sum : // unsigned , default = 0 sum of blend_12vs3 with the debug window

**Table 9-1121 NR4\_COEF12\_SUM 0x3727**

Bit(s)	R/W	Default	Description
31: 0	R.O	0	ro_nr4_coef12_sum : // signed , default = 0 sum of coef_blt_blend12 with the debug window, under 8 bits precision

**Table 9-1122 NR4\_COEF123\_SUM 0x3728**

Bit(s)	R/W	Default	Description
31: 0	R.O	0	ro_nr4_coef123_sum : // signed , default = 0 sum of coef_final with the debug window, under 8 bits precision

Table 9-1123 NR\_DB\_FLT\_CTRL 0x3738

Bit(s)	R/W	Default	Description
26	R/W	0	reg_nrdeband_reset1 : // unsigned , default = 0 0 : no reset seed 1: reload chroma seed
25	R/W	0	reg_nrdeband_reset0 : // unsigned , default = 0 0 : no reset seed 1: reload luma seed
24	R/W	0	reg_nrdeband_rgb : // unsigned , default = 0 0 : yuv 1: RGB
23	R/W	1	reg_nrdeband_en11 : // unsigned , default = 1 debanding registers of side lines, [0] for luma, same for below
22	R/W	1	reg_nrdeband_en10 : // unsigned , default = 1 debanding registers of side lines, [1] for chroma, same for below
21	R/W	1	reg_nrdeband_siderand : // unsigned , default = 1 options to use side two lines use the rand, instead of use for the YUV three component of middle line, 0: seed [3]/bandrand[3] for middle line yuv; 1: seed[3]/bandrand[3] for nearby three lines Y;
20	R/W	0	reg_nrdeband_randmode : // unsigned , default = 0 mode of rand noise adding, 0: same noise strength for all difs; else: strenght of noise will not exceed the difs, MIN((pPKReg->reg_nrdeband_bandrand[m]), noise[m])
19:17	R/W	6	reg_nrdeband_bandrand2 : // unsigned , default = 6
15:13	R/W	6	reg_nrdeband_bandrand1 : // unsigned , default = 6
11: 9	R/W	6	reg_nrdeband_bandrand0 : // unsigned , default = 6
7	R/W	1	reg_nrdeband_hpxor1 : // unsigned , default = 1 debanding random hp portion xor, [0] for luma
6	R/W	1	reg_nrdeband_hpxor0 : // unsigned , default = 1 debanding random hp portion xor, [1] for chroma
5	R/W	1	reg_nrdeband_en1 : // unsigned , default = 1 debanding registers, for luma
4	R/W	1	reg_nrdeband_en0 : // unsigned , default = 1 debanding registers, for chroma
3: 2	R/W	2	reg_nrdeband_lpf_mode1 : // unsigned , default = 2 lpf mode, 0: 3x3, 1:3x5; 2: 5x5; 3:5x7
1: 0	R/W	2	reg_nrdeband_lpf_mode0 : // unsigned , default = 2 lpf mode, 0: 3x3, 1:3x5; 2: 5x5; 3:5x7

Table 9-1124 NR\_DB\_FLT\_YC\_THRD 0x3739

Bit(s)	R/W	Default	Description
31:28	R/W	9	reg_nrdeband_luma_th3 : // unsigned , default = 9 threshold to  Y-Ylpf , if < th [0] use lpf
27:24	R/W	7	reg_nrdeband_luma_th2 : // unsigned , default = 7 elseif <th[1] use (lpf*3 + y)/4
23:20	R/W	6	reg_nrdeband_luma_th1 : // unsigned , default = 6 elseif <th[1] use (lpf*3 + y)/4elseif <th[2] (lpf*1 + y)/2
19:16	R/W	5	reg_nrdeband_luma_th0 : // unsigned , default = 5 elseif <th[1] use (lpf*3 + y)/4elseif elseif <th[3] (lpf*1 + 3*y)/4; else
15:12	R/W	9	reg_nrdeband_chrm_th3 : // unsigned , default = 9 threshold to  Y-Ylpf , if < th [0] use lpf
11: 8	R/W	7	reg_nrdeband_chrm_th2 : // unsigned , default = 7 elseif <th[1] use (lpf*3 + y)/4

Bit(s)	R/W	Default	Description
7: 4	R/W	6	reg_nrdeband_chrm_th1 : // unsigned , default = 6 elseif <th[1] use (lpf*3 + y)/4elseif <th[2] (lpf*1 + y)/2
3: 0	R/W	5	reg_nrdeband_chrm_th0 : // unsigned , default = 5 elseif <th[1] use (lpf*3 + y)/4elseif elseif

Table 9-1125 NR\_DB\_FLT\_RANLUT 0x373a

Bit(s)	R/W	Default	Description
23:21	R/W	1	reg_nrdeband_randslut7 : // unsigned , default = 1 lut0
20:18	R/W	1	reg_nrdeband_randslut6 : // unsigned , default = 1 lut0
17:15	R/W	1	reg_nrdeband_randslut5 : // unsigned , default = 1 lut0
14:12	R/W	1	reg_nrdeband_randslut4 : // unsigned , default = 1 lut0
11: 9	R/W	1	reg_nrdeband_randslut3 : // unsigned , default = 1 lut0
8: 6	R/W	1	reg_nrdeband_randslut2 : // unsigned , default = 1 lut0
5: 3	R/W	1	reg_nrdeband_randslut1 : // unsigned , default = 1 lut0
2: 0	R/W	1	reg_nrdeband_randslut0 : // unsigned , default = 1 lut0

Table 9-1126 NR\_DB\_FLT\_PXI\_THRD 0x373b

Bit(s)	R/W	Default	Description
25:16	R/W	0	reg_nrdeband_yc_th1 : // unsigned , default = 0 to luma/ u/v  for using the denoise
9: 0	R/W	0	reg_nrdeband_yc_th0 : // unsigned , default = 0 to luma/ u/v  for using the denoise

Table 9-1127 NR\_DB\_FLT\_SEED\_Y 0x373c

Bit(s)	R/W	Default	Description
31: 0	R/W	162143-8240	reg_nrdeband_seed0 : // unsigned , default = 1621438240 noise adding seed for Y. seed[0]= 0x60a52f20; as default

Table 9-1128 NR\_DB\_FLT\_SEED\_U 0x373d

Bit(s)	R/W	Default	Description
31: 0	R/W	162143-8247	reg_nrdeband_seed1 : // unsigned , default = 1621438247 noise adding seed for U. seed[0]= 0x60a52f27; as default

Table 9-1129 NR\_DB\_FLT\_SEED\_V 0x373e

Bit(s)	R/W	Default	Description
31: 0	R/W	162143-8242	reg_nrdeband_seed2 : // unsigned , default = 1621438242 noise adding seed for V. seed[0]= 0x60a52f22; as default



Table 9-1130 NR\_DB\_FLT\_SEED3 0x373f

Bit(s)	R/W	Default	Description
31: 0	R/W	162143-8242	reg_nrdeband_seed3 : // unsigned , default = 1621438242 noise adding seed for V. seed[0]= 0x60a52f22; as default

### 9.2.3.15 VIUB Top-Level Registers

Table 9-1131 VIU\_SW\_RESET 0x1a01

Bit(s)	R/W	Default	Description
29	R/W	0	di_dsr1to2_reset : // unsigned , default = 0
28	R/W	0	vd2_lbuf_reset : // unsigned , default = 0
27	R/W	0	afbc_dec1_reset : // unsigned , default = 0
26	R/W	0	vd2_reset : // unsigned , default = 0
25	R/W	0	vd1_lbuf_reset : // unsigned , default = 0
24	R/W	0	afbc_dec0_reset : // unsigned , default = 0
23	R/W	0	vd1_reset : // unsigned , default = 0
22	R/W	0	osd1_afbcd_regs_reset : // unsigned , default = 0
21	R/W	0	osd1_afbcd_logic_reset : // unsigned , default = 0 Only active when MALI_AFBCD_TOP_CTRL[23] high
20	R/W	0	afbc_arb_reg_reset : // unsigned , default = 0
19	R/W	0	afbc_arb_reset : // unsigned , default = 0
17	R/W	0	osd4_reset : // unsigned , default = 0
16	R/W	0	osd3_reset : // unsigned , default = 0
15	R/W	0	osd2_reset : // unsigned , default = 0
14	R/W	0	osd1_reset : // unsigned , default = 0
12	R/W	0	vpp_axi_reset : // unsigned , default = 0
8	R/W	0	osd24bld_reset : // unsigned , default = 0
7	R/W	0	osd13bld_reset : // unsigned , default = 0
6	R/W	0	prime_reset : // unsigned , default = 0
5	R/W	0	hist_spl_reset : // unsigned , default = 0
4	R/W	0	ldim_stts_reset : // unsigned , default = 0
3	R/W	0	dolby1b_reset : // unsigned , default = 0
2	R/W	0	dolby1a_reset : // unsigned , default = 0
1	R/W	0	dolby0_reset : // unsigned , default = 0
0	R/W	0	vpp_reset : // unsigned , default = 0

**Table 9-1132 VIU\_SW\_RESET0 0x1a02**

Bit(s)	R/W	Default	Description
2	R/W	0	software : reset for mcinfoford_mif // unsigned , default = 0
1	R/W	0	software : reset for mcinfofowr_mif // unsigned , default = 0
0	R/W	0	software : reset for mcvecrd_mif // unsigned , default = 0

**Table 9-1133 VIU\_SECURE\_REG 0x1a04**

Bit(s)	R/W	Default	Description
19:18	R/W	0	prebld_en : // unsigned , default = 0
17:16	R/W	0	postbld_en : // unsigned , default = 0
9	R/W	0	matrx_i : probe // unsigned , default = 0
8	R/W	0	dolby_core3 : // unsigned , default = 0
7	R/W	0	dolby_graphic : // unsigned , default = 0
6	R/W	0	dolby_video : // unsigned , default = 0
5	R/W	0	primel : // unsigned , default = 0

**Table 9-1134 DOLBY\_INT\_STAT 0x1a05**

Bit(s)	R/W	Default	Description
3:0	R/W	0	dolby_int_state : // unsigned , default = 0

**Table 9-1135 VIU\_MISC\_CTRL0 0x1a06**

Bit(s)	R/W	Default	Description
8	R/W	0	vsync_int_ctrl : default = 0
0	R/W	0	scan_reg : default = 0

**Table 9-1136 VIU\_MISC\_CTRL1 0x1a07**

Bit(s)	R/W	Default	Description
31:0	R/W	0	viu_misc_ctrl1 : // unsigned , default = 0

**Table 9-1137 VIU\_SECURE\_REG1 0x1a08**

Bit(s)	R/W	Default	Description
31:0	R/W	0	viu_secure_reg1 : // unsigned , default = 0

Table 9-1138 VIU\_SECURE\_REG2 0x1a09

Bit(s)	R/W	Default	Description
31:0	R/W	0	viu_secure_reg2 : // unsigned , default = 0

Table 9-1139 VD1\_AFBCD0\_MISC\_CTRL 0x1a0a

Bit(s)	R/W	Default	Description
21:20	R/W	0	vd1_go_field_sel : // unsigned , default = 0 0: go_file 1: go_field_post 2: goFiled_pre
16	R/W	0	vd1_lbuf_ram_sel : // unsigned , default = 0 0: NO share ram 1: afbc0 share ext ram
15:14	R/W	0	vd1_in_mux_sel : // unsigned , default = 0 0: vd1 to dably 2: vd1 to prime1
13:12	R/W	0	vd1_axi_sel : // unsigned , default = 0 0: afbc0 mif to axi 1: vd1 mif to axi
11	R/W	0	afbc0_osd3_mux_vd1 : // unsigned , default = 0 0: afbc0 to vd1 1: osd3 to vd1
10	R/W	0	afbc_vd1_sel : // unsigned , default = 0 0: vd1_mif to vpp 1: afbc0_mif
9	R/W	0	afbc0_mux_vpp_mad : // unsigned , default = 0 0: afbc0 to vpp 1: afbc0 to di
8	R/W	0	di_mif0_en : // unsigned , default = 0 0: select mif to vpp 1: mif to di
7:0	R/W	0	afbc0_gclk_ctrl : // unsigned , default = 0

Table 9-1140 VD2\_AFBCD1\_MISC\_CTRL 0x1a0b

Bit(s)	R/W	Default	Description
31:24	R/W	0	vd2_osd_mux_alpha : // unsigned , default = 0 config vd2_osd alpha value.
21:20	R/W	0	vd1_go_field_sel : // unsigned , default = 0 0: go_file 1: go_field_post 2: goFiled_pre
16	R/W	0	vd2_lbuf_ram_sel : // unsigned , default = 0 0: NO share ram 1: afbc1 share ext ram
15:14	R/W	0	vd2_in_mux_sel : // unsigned , default = 0 0: afbc2_vd2 to vd2 2: osd4 to vd2
13:12	R/W	0	vd2_axi_sel : // unsigned , default = 0 0: afbc1 mif to axi 1: vd2 mif to axi
11	R/W	0	afbc1_osd4_mux_vd1 : // unsigned , default = 0 0: afbc1 to vd1 1: osd4 to vd2
10	R/W	0	afbc_vd2_sel : // unsigned , default = 0 0: vd2_mif to vpp 1: afbc1_mif
9	R/W	0	afbc1_mux_vpp_mad : // unsigned , default = 0 0: afbc1 to vpp 1: afbc1 to di
8	R/W	0	afbc_2mad_out_sel : // unsigned , default = 0 0: select vd1 to di 1: vd2 to di
7:0	R/W	0	afbc0_gclk_ctrl : // unsigned , default = 0

Table 9-1141 DOLBY\_PATH\_CTRL 0x1a0c

Bit(s)	R/W	Default	Description
7	R/W	0	vpp_osd2_ext_mod : // unsigned , default = 0 // 0: 12bits 1: 10bits
6	R/W	0	vpp_osd1_ext_mod : // unsigned , default = 0 // 0: 12bits 1: 10bits
5	R/W	0	dolby1_vd2_ext_mod : // unsigned , default = 0 // 0: 12bits 1: 10bits
4	R/W	0	dolby0_vd1_ext_mod : // unsigned , default = 0 // 0: 12bits 1: 10bits
3	R/W	0	Osd2_dolby_bypass_en : // unsigned , default = 0
2	R/W	0	Osd1_dolby_bypass_en
1	R/W	0	Vd2_dolby_bypass_en
0	R/W	0	Vd1dolby_bypass_en

Table 9-1142 WR\_BACK\_MISC\_CTRL 0x1a0d

Bit(s)	R/W	Default	Description
1	R/W	0	wrbak_chan1_hsyn_en : // unsigned , default = 0 vd1 wrbak hsync enable
0	R/W	0	wrbak_chan0_hsyn_en : // unsigned , default = 0 vd0 wrbak hsync enable

Table 9-1143 OSD\_PATH\_MISC\_CTRL 0x1a0e

Bit(s)	R/W	Default	Description
7:4	R/W	0	osd_axi_sel : // unsigned , default = 0 osd_axi_sel[0] 1:OSD1 get data from mali_afbcd 0: OSD1 get data from DDR osd_axi_sel[1] 1:OSD2 get data from mali_afbcd 0: OSD2 get data from DDR osd_axi_sel[2] 1:OSD3 get data from mali_afbcd 0: OSD3 get data from DDR osd_axi_sel[3] reserved
3	R/W	0	osd4_in_mux_sel : // unsigned , default = 0 0: osd4 to vpp 1: vd2_osd4 to vpp
2	R/W	0	osd4_mux_vpp_vd2 : // unsigned , default = 0 0: osd4 to vpp 1: osd4 to vd2
1	R/W	0	osd3_in_mux_sel : // unsigned , default = 0 0: osd3 to vpp 1: vd2_osd3 to vpp
0	R/W	0	osd3_mux_vpp_vd1 : // unsigned , default = 0 0: osd3 to vpp 1: osd3 to vd1

Table 9-1144 MALI\_AFBCD\_TOP\_CTRL 0x1a0f

Bit(s)	R/W	Default	Description
31	R.O	0	ro_mali_dec_active : // unsigned , default = 0
23	R/W	0	Mali afbcd logic rst mode 1:logic rest controll by VIU_SW_RESET[21] 0:logic reset by vsync singal,don't need software process
17:12	R/W	0	gclk_ctrl_osd1_afbcd : // unsigned , default = 0 mail afbc gate clock
8	R/W	1	axim_data_128b : // unsigned , default = 1 0: axi bus width=64 1: 128bit
6:4	R/W	7	axim_max_len : // unsigned , default = 7
2:0	R/W	5	axim_outstanding_trans : // unsigned , default =5

Table 9-1145 VIU\_GCLK\_CTRL 0x1a4f

Bit(s)	R/W	Default	Description
7:0	R/W	0	viu_gclk_ctrl : // unsigned , default =0

### 9.2.3.16 VPP\_ARB\_CTRL Registers

Table 9-1146 VPP\_AFBC\_RDARB\_MODE 0x3970

Bit(s)	R/W	Default	Description
31-24	R/W	0	unused
23-20	R/W	0	Rdarb_sel
16	R/W	0	Rdarb_arb_mode
1-0	R/W	0	Rdarb_gate_clk_ctrl

Table 9-1147 VPP\_AFBC\_RDARB\_REQEN\_SLV 0x3971

Bit(s)	R/W	Default	Description
3-0	R/W	0	Rdarb_dc_req_en 1: Request is valid, 0: Invalid Bit0 : osd1 Bit1 : osd2 Bit2 : osd3 Bit3 : osd4

Table 9-1148 VPP\_AFBC\_RDARB\_WEIGHT0\_SLV 0x3972

Bit(s)	R/W	Default	Description
23-0	R/W	0	Rddc_weigh_sxn

Table 9-1149 VPP\_AFBC\_ARB\_DBG\_CTRL 0x3974

Bit(s)	R/W	Default	Description
31-0	RO	0	Det_cmd_ctrl

**Table 9-1150 VPP\_RDARB\_MODE 0x3978**

Bit(s)	R/W	Default	Description
27-20	R/W	0	Rdarb_sel 1: Request is valid, 0: Invalid Bit20: osd1 Bit21: osd2 Bit22: vd1 Bit23: vd2 Bit24: osd3 Bit25: osd4 Bit26: dolby0 Bit27:mali_afbc
17:16	R/W	0	Rdarb_arb_mode
3-0	R/W	0	Rdarb_gate_clk_ctrl

**Table 9-1151 VPP\_RDARB\_REQEN\_SLV 0x3979**

Bit(s)	R/W	Default	Description
15-0	R/W	0	Rdarb_dc_req_en 1: Request is valid, 0: Invalid Bit0: osd1 come from axi_port0 Bit1: osd2 come from axi_port0 Bit2: vd1 come from axi_port0 Bit3: vd2 come from axi_port0 Bit4: osd3 come from axi_port0 Bit5: osd4 come from axi_port0 Bit6: dolby0 come from axi_port0 Bit7:mali_afbc come from axi_port0 Bit8: osd1 come from axi_port1 Bit9: osd2 come from axi_port1 Bit10: vd1 come from axi_port1 Bit11: vd2 come from axi_port1 Bit12: osd3 come from axi_port1 Bit13: osd4 come from axi_port1 Bit14: dolby0 come from axi_port1 Bit15:mali_afbc come from axi_port1

**Table 9-1152 VPP\_RDARB\_WEIGHT0\_SLV 0x397a**

Bit(s)	R/W	Default	Description
29-0	R/W	0	Rddc_weigh_sxn

**Table 9-1153 VPP\_RDARB\_WEIGHT1\_SLV 0x397b**

Bit(s)	R/W	Default	Description
17-0	RO	0	Rddc_weigh_sxn

**Table 9-1154 VPP\_ARB\_DBG\_CTRL 0x397c**

Bit(s)	R/W	Default	Description
31-0	RO	0	Det_cmd_ctrl

### 9.2.3.17 VD1 Path vd\_rmem\_if0 Registers

Table 9-1155 VD1 Path vd\_rmem\_if0 Registers VD1\_IF0\_GEN\_REG 0x3200

Bit(s)	R/W	Default	Description
31	R/W	0	ENABLE_FREE_CLK. 0: Gated clock for power saving 1: Free-running clock to drive logic
30	R/W	0	SW_RESET: Write 1 to this bit to generate a pulse to reset everything except registers.
29	R/W	0	RESET_ON_GO_FIELD: Define whether to reset state machines on go_field pulse. 0: No reset on go_field 1: go_field reset everything except registers
28	R/W	0	URGENT_CHROMA: Set urgent level for chroma fifo request from DDR. 0: Non urgent 1: Urgent
27	R/W	0	URGENT_LUMA: Set urgent level for luma fifo request from DDR. 0: Non urgent 1: Urgent
26	R/W	0	Chroma_end_at_last_line: For chroma line, similar to luma_end_at_last_line, as below. Not used if data are stored together in one canvas.
25	R/W	0	Luma_end_at_last_line: Control whether continue outputting luma line past last line. 0: Repeat the last line or dummy pixels, after past the last line 1: Stop outputting data, once past the last line.
24-19	R/W	4	Hold_lines: After go_field, the number of lines to hold before the module is enabled.
18	R/W	0	LAST_LINE: This bit controls whether we simply repeat the last line or we push dummy pixels. '1' tells the state-machines to repeat the last line using the dummy pixels defined in the register below. '0' indicates that the state-machine should re-read the last line of real data.
17	R	0	Busy status of the state-machines. '1' = busy, '0' = idle
16	R/W	0	DEMUX_MODE: 0 = 4:2:2, 1 = RGB (24-bit). This value is used to control the demuxing logic when the picture is stored together. When a picture is stored together, the data is read into a single FIFO (the Y FIFO) and must be demultiplexed into the "drain" outputs. In the case of 4:2:2 the data is assumed to be stored in memory in 16-bit chunks: <YCb><YCr><YCb><YCr>,... the Y, Cb and Cr 8-bit values are pulled from the single Y-FIFO and sent out in pairs.  This value is only valid when the picture is stored together. If the picture is separated into different canvases, then this bit field is ignored.
15-14	R/W	0	BYTES_PER_PIXEL: This value is used to determine how many bytes are associated with each pixel. 0: This value should be used if the image is stored separately (e.g. RGB or Y, Cb, Cr). 1: This value should be used if the data is 4:2:2 data stored together. In this case each pixel, YCb or YCr, is 16-bits (two bytes). 2: This value should be used if the RGB (24-bit) data is stored together. 3: reserved for future use (alpha RGB).
13-12	R/W	0	DDR_BURST_SIZE_CR: This value is used to control the DDR burst request size for the Cr FIFO. 0: Maximum burst = 24 64-bit values 1: Maximum burst = 32 64-bit values 2: Maximum burst = 48 64-bit values 3: Maximum burst = 64 64-bit values

Bit(s)	R/W	Default	Description
11-10	R/W	0	DDR_BURST_SIZE_CB: This value is used to control the DDR burst request size for the Cb FIFO. 0: Maximum burst = 24 64-bit values 1: Maximum burst = 32 64-bit values 2: Maximum burst = 48 64-bit values 3: Maximum burst = 64 64-bit values
9-8	R/W	0	DDR_BURST_SIZE_Y: This value is used to control the DDR burst request size for the Y FIFO. 0: Maximum burst = 24 64-bit values 1: Maximum burst = 32 64-bit values 2: Maximum burst = 48 64-bit values 3: Maximum burst = 64 64-bit values
7	R/W	0	MANUAL_START_FRAME: non-latching bit that can be used to simulate the go_field signal for simulation.
6	R/W	0	CHRO_RPT_LASTL_CTRL: This bit controls whether to allow VPP's chroma-repeat request. 0: Chroma-repeat pulses from VPP are ignored 1: Chroma-repeat pulses from VPP are used.
5	R/W	0	Unused
4	R/W	0	LITTLE_ENDIAN: This bit defines the endianness of the memory data . 0: Pixel data are stored big-endian in memory 1: Pixel data are stored little-endian in memory
3	R/W	0	Chroma_hz_avg: For chroma line output control, similar to luma_hz_avg, as below. Not used if data are stored together in one canvas.
2	R/W	0	Luma_hz_avg: Enable output half amount of data per line to save bandwidth. 0: Output every pixel per line 1: Output half line, each data averaged between every 2 pixels Note: For 4:2:2 mode data stored together in one canvas, only do averaging over luma data.
1	R/W	0	SEPARATE_EN: Set this bit to 1 if the image is in separate canvas locations.
0	R/W	0	ENABLE: This bit is set to 1 to enable the FIFOs and other logic. This bit can be set to 0 to cleanup and put the logic into an IDLE state.

Table 9-1156 VD1\_IF0\_CANVAS0 – Picture 0 0x3201

Bit(s)	R/W	Default	Description
31-24	R/W	0	unused
23-16	R/W	0	CANVAS0_ADDR2: Canvas table address for picture 0 for component 2 (Cr FIFO). This value is ignored when the picture is stored together
15-8	R/W	0	CANVAS0_ADDR1: Canvas table address for picture 0 for component 1 (Cb FIFO). This value is ignored when the picture is stored together
7-0	R/W	0	CANVAS0_ADDR0: Canvas table address for picture 0 for component 0 (Y FIFO).

Table 9-1157 VD1\_IF0\_CANVAS1 – Picture 1 0x3202

Bit(s)	R/W	Default	Description
31-24	R/W	0	unused
23-16	R/W	0	CANVAS1_ADDR2: Canvas table address for picture 1 for component 2 (Cr FIFO). This value is ignored when the picture is stored together



Bit(s)	R/W	Default	Description
15-8	R/W	0	CANVAS1_ADDR1: Canvas table address for picture 1 for component 1 (Cb FIFO). This value is ignored when the picture is stored together
7-0	R/W	0	CANVAS1_ADDR0: Canvas table address for picture 1 for component 0 (Y FIFO).

Table 9-1158 VD1\_IF0\_LUMA\_X0 – Picture 0 0x3203

Bit(s)	R/W	Default	Description
31	R/W	0	Unused
30-16	R/W	0	LUMA_X_END0: Picture 0, luma X end value
15	R/W	0	Unused
14-0	R/W	0	LUMA_X_START0: Picture 0, luma X start value

Table 9-1159 VD1\_IF0\_LUMA\_Y0 – Picture 0 0x3204

Bit(s)	R/W	Default	Description
31-29	R/W	0	Unused
28-16	R/W	0	LUMA_Y_END0: Picture 0, luma Y end value
15-13	R/W	0	Unused
12-0	R/W	0	LUMA_Y_START0: Picture 0, luma Y start value

Table 9-1160 VD1\_IF0\_CHROMA\_X0 – Picture 0 0x3205

Bit(s)	R/W	Default	Description
31	R/W	0	Unused
30-16	R/W	0	CHROMA_X_END0: Picture 0, chroma X end value. This value is only used when the picture is not stored together.
15	R/W	0	Unused
14-0	R/W	0	CHROMA_X_START0: Picture 0, chroma X start value. This value is only used when the picture is not stored together.

Table 9-1161 VD1\_IF0\_CHROMA\_Y0 – Picture 0 0x3206

Bit(s)	R/W	Default	Description
31-29	R/W	0	Unused
28-16	R/W	0	CHROMA_Y_END0: Picture 0, chroma Y end value. This value is only used when the picture is not stored together.
15-13	R/W	0	Unused
12-0	R/W	0	CHROMA_Y_START0: Picture 0, chroma Y start value. This value is only used when the picture is not stored together.

**Table 9-1162 VD1\_IF0\_LUMA\_X1 – Picture 1 0x3207**

Bit(s)	R/W	Default	Description
31	R/W	0	Unused
30-16	R/W	0	LUMA_X_END1: Picture 1, luma X end value
15	R/W	0	Unused
14-0	R/W	0	LUMA_X_START1: Picture 1, luma X start value

**Table 9-1163 VD1\_IF0\_LUMA\_Y1 – Picture 1 0x3208**

Bit(s)	R/W	Default	Description
31-29	R/W	0	Unused
28-16	R/W	0	LUMA_Y_END1: Picture 1, luma Y end value
15-13	R/W	0	Unused
12-0	R/W	0	LUMA_Y_START1: Picture 1, luma Y start value

**Table 9-1164 VD1\_IF0\_CHROMA\_X1 – Picture 1 0x3209**

Bit(s)	R/W	Default	Description
31	R/W	0	Unused
30-16	R/W	0	CHROMA_X_END1: Picture 1, chroma X end value. This value is only used when the picture is not stored together.
15	R/W	0	Unused
14-0	R/W	0	CHROMA_X_START1: Picture 1, chroma X start value. This value is only used when the picture is not stored together.

**Table 9-1165 VD1\_IF0\_CHROMA\_Y1 – Picture 1 0x320A**

Bit(s)	R/W	Default	Description
31-29	R/W	0	Unused
28-16	R/W	0	CHROMA_Y_END1: Picture 1, chroma Y end value. This value is only used when the picture is not stored together.
15-13	R/W	0	Unused
12-0	R/W	0	CHROMA_Y_START1: Picture 1, chroma Y start value. This value is only used when the picture is not stored together.

**Table 9-1166 VD1\_IF0\_REPEAT\_LOOP – Pictures 0 and 1 0x320B**

Bit(s)	R/W	Default	Description
31-24	R/W	0	CHROMA_RPT_LOOP1: Repeat loop for Picture 1. Bits[6:4] = start loop pointer, bits [2:0] = end loop pointer. Bits [7] and [3] are ignored.
23-16	R/W	0	LUMA_RPT_LOOP1: Repeat loop for Picture 1. Bits[6:4] = start loop pointer, bits [2:0] = end loop pointer. Bits [7] and [3] are ignored.

Bit(s)	R/W	Default	Description
15-8	R/W	0	CHROMA_RPT_LOOP0: Repeat loop for Picture 0. Bits[6:4] = start loop pointer, bits [2:0] = end loop pointer. Bits [7] and [3] are ignored.
7-0	R/W	0	LUMA_RPT_LOOP0: Repeat loop for Picture 0. Bits[6:4] = start loop pointer, bits [2:0] = end loop pointer. Bits [7] and [3] are ignored.

**Table 9-1167 VD1\_IF0\_LUMA0\_RPT\_PAT – Picture 0 LUMA repeat pattern 0x320C**

Bit(s)	R/W	Default	Description
31-0	R/W	0	Luma repeat/skip pattern for picture 0

Bits	Pattern Index	Pattern description
31-28	7	Repeat/skip pattern: Bit[3] = 0 indicates repeat. Bit[3] = 1 indicates either skip, or output this line and then skip. How to interpret this bit depends on the value of the previous pattern's Bit[3]. If previous Bit[3]=0, then skip; If previous Bit[3]=1, then output this line and then skip. Bits[2:0] indicate the skip / repeat count. Blow is an example of consecutive patterns, the start line is line 0: {0010} Repeat this line (line 0) two more times for a total of three line reads. Proceed to next line (line 1). {0000} Don't repeat this line (line 1). This line will be read just once. Proceed to next line (line 2). {1000} Skip one line (line 2) to get to the next line (line 3). The skip implies that the next line (line 3) should be read at least once. {1011} Read this line (line 3) once, and then skip the next four lines to get to the next line (line 8). The skip implies that the next line (line 8) should be read at least once. {0100} Repeat this line (line 8) four more times for a total of five line read. Proceed to next line (line 9). {1001} Skip two lines to get to the next line (line 11). The skip implies that the next line (line 11) should be read at least once.
27-24	6	See pattern definition above.
23-20	5	See pattern definition above.
19-16	4	See pattern definition above.
15-12	3	See pattern definition above.
11-8	2	See pattern definition above.
7-4	1	See pattern definition above.
3-0	0	See pattern definition above.

**Table 9-1168 VD1\_IF0\_CHROMA0\_RPT\_PAT – Picture 0 CHROMA repeat pattern 0x320D**

Bit(s)	R/W	Default	Description
31-0	R/W	0	Chroma repeat/skip pattern for picture 0. See picture 0 luma pattern for description. This value is only used when the picture is not stored together.

**Table 9-1169 VD1\_IF0\_LUMA1\_RPT\_PAT – Picture 1 LUMA repeat pattern 0x320E**

Bit(s)	R/W	Default	Description
31-0	R/W	0	Luma repeat/skip pattern for picture 1. See picture 0 luma pattern for description.

**Table 9-1170 VD1\_IF0\_CHROMA1\_RPT\_PAT – Picture 1 CHROMA repeat pattern 0x320F**

Bit(s)	R/W	Default	Description
31-0	R/W	0	Chroma repeat/skip pattern for picture 1. See picture 0 luma pattern for description. This value is only used when the picture is not stored together.

**Table 9-1171 VD1\_IF0\_LUMA\_PSEL – Picture 0 and 1's LUMA 0x3210**

Bit(s)	R/W	Default	Description
31-28	R/W	0	unused
27-26	R/W	0	Luma_psel_mode: controls whether it's single-picture or two-picture mode. {00} Only picture 0 is used. Ignore settings defined in Luma_psel_last_line, Luma_psel_pattern and Luma_psel_loop. {01} Only picture 1 is used. Ignore settings defined in Luma_psel_last_line, Luma_psel_pattern and Luma_psel_loop. {1x} Two-picture mode.
25-24	R/W	0	Luma_psel_last_line: select which picture's last line to output, during repeat last line mode. Bit[0]=0, when picture 0 past the last line, use picture 0's last line during repeat last line mode; Bit[0]=1, when picture 0 past the last line, use picture 1's last line during repeat last line mode; Bit[1]=0, when picture 1 past the last line, use picture 0's last line during repeat last line mode; Bit[1]=1, when picture 1 past the last line, use picture 1's last line during repeat last line mode.
23-8	R/W	0	Luma_psel_pattern. If the value of the bit pointed by the loop pointer is 0, output picture 0's luma line, if the bit value is 1, output picture 1's luma line.
7-4	R/W	0	Luma_psel_loop start pointer.
3-0	R/W	0	Luma_psel_loop end pointer.

**Table 9-1172 VD1\_IF0\_CHROMA\_PSEL – Picture 0 and 1's CHROMA 0x3211**

Bit(s)	R/W	Default	Description
31-28	R/W	0	unused
27-26	R/W	0	Chroma_psel_mode: see luma_psel_mode. This value is only used when the picture is not stored together.
25-24	R/W	0	Chroma_psel_last_line: See luma_psel_last_line. This value is only used when the picture is not stored together.
23-8	R/W	0	Chroma_psel_pattern. If the value of the bit pointed by the loop pointer is 0, output picture 0's chroma line, if the bit value is 1, output picture 1's chroma line. This value is only used when the picture is not stored together.
7-4	R/W	0	Chroma_psel_loop start pointer. This value is only used when the picture is not stored together.
3-0	R/W	0	Chroma_psel_loop end pointer. This value is only used when the picture is not stored together.

Table 9-1173 VD1\_IF0\_DUMMY\_PIXEL 0x3212

Bit(s)	R/W	Default	Description
31-24	R/W	0x00	Y or R dummy pixel value ,8bit
23-16	R/W	0x80	Cb or G dummy pixel value ,8bit
15-8	R/W	0x80	Cr or B dummy pixel value ,8bit
7-0	R/W	0	unused

VD1\_RANGE\_MAP\_Y 0x321A

VD1\_RANGE\_MAP\_CB 0x321B

VD1\_RANGE\_MAP\_CR 0x321C

Output data range conversion function:

$$Y[n] = \text{clip} ( \text{Round} ( ( Y[n] + \text{DIN\_OFFSET} ) * \text{RANGE\_MAP\_COEF} ) / ( 1 \ll \text{RANGE\_MAP\_SR} ) + \text{DOUT\_OFFSET} );$$

To perform VC-1 range reduction, set the following:

DIN\_OFFSET = 0x180 = -128;

RANGE\_MAP\_COEF = RANGE\_MAPY + 9

RANGE\_MAP\_SR = 3

DOUT\_OFFSET = 0x080 = 128

To get the equivalent function:

$$Y[n] = \text{clip}(((Y[n]-128) * (\text{RANGE\_MAPY} + 9) + 4) \gg 3) + 128);$$

Bit(s)	R/W	Default	Description
31-23	R/W	0	DIN_OFFSET
22-15	R/W	0	RANGE_MAP_COEF
14	R/W	0	unused
13-10	R/W	0	RANGE_MAP_SR
9-1	R/W	0	DOUT_OFFSET
0	R/W	0	RANGE_MAP_EN

Table 9-1174 VD1\_IF0\_GEN\_REG2 0x321D

Bit(s)	R/W	Default	Description
31-2	R/W	0	unused
1-0	R/W	0	COLOR_MAP: Define color map for NV12 or NV21 mode. Only applicable when VD1_IF0_GEN_REG.SEPARATE_EN = 1. 0: NOT NV12 or NV21; 1: NV12 (CbCr); 2: NV21 (CrCb).

**Table 9-1175 VD1\_IF0\_GEN\_REG3 0x3216**

Bit(s)	R/W	Default	Description
11-10	R/W	0	cntl_dbg_mode
9-8	R/W	0	cntl_bits_mode : 0->8bit 1->10bit 422 2->10bit 444
6-4	R/W	3	cntl_blk_len
2-1	R/W	1	cntl_burst_len
0	R/W	1	cntl_64bit_rev

**Table 9-1176 VIU\_VD1\_FMT\_CTRL 0x3218**

Bit(s)	R/W	Default	Description
31	R/W	0	gate_clk_en. 0=No clock gating, free-running; 1=Enable clock gating for power saving.
30	R/W	0	soft_rst. If true, reset formatters.
29	R/W	0	unused
28	R/W	0	if true, horizontal formatter use repeating to generate pixel, otherwise use bilinear interpolation
27-24	R/W	0	horizontal formatter initial phase
23	R/W	0	horizontal formatter repeat pixel 0 enable
22-21	R/W	0	horizontal Y/C ratio, 00: 1:1, 01: 2:1, 10: 4:1
20	R/W	0	horizontal formatter enable
19	R/W	0	if true, always use phase0 while vertical formater, meaning always repeat data, no interpolation
18	R/W	0	if true, disable vertical formatter chroma repeat last line
17	R/W	0	vertical formatter dont need repeat line on phase0, 1: enable, 0: disable
16	R/W	0	vertical formatter repeat line 0 enable
15-12	R/W	0	vertical formatter skip line num at the beginning
11-8	R/W	0	vertical formatter initial phase
7-1	R/W	0	vertical formatter phase step (3.4)
0	R/W	0	vertical formatter enable

**Table 9-1177 VIU\_VD1\_FMT\_W 0x3219**

Bit(s)	R/W	Default	Description
27-16	R/W	0	horizontal formatter width
11-0	R/W	0	vertical formatter width

### 9.2.3.18 VD2 Path vd\_rmem\_if0 Registers

VD2\_IF0\_GEN\_REG 0x3220

Same as VD1\_IF0\_GEN\_REG  
VD2\_IF0\_CANVAS0 0x3221  
Same as VD1\_IF0\_CANVAS0  
VD2\_IF0\_CANVAS1 0x3222  
Same as VD1\_IF0\_CANVAS1  
VD2\_IF0\_LUMA\_X0 0x3223  
Same as VD1\_IF0\_LUMA\_X0  
VD2\_IF0\_LUMA\_Y0 0x3224  
Same as VD1\_IF0\_LUMA\_Y0  
VD2\_IF0\_CHROMA\_X0 0x3225  
Same as VD1\_IF0\_CHROMA\_X0  
VD2\_IF0\_CHROMA\_Y0 0x3226  
Same as VD1\_IF0\_CHROMA\_Y0  
VD2\_IF0\_LUMA\_X1 0x3227  
Same as VD1\_IF0\_LUMA\_X1  
VD2\_IF0\_LUMA\_Y1 0x3228  
Same as VD1\_IF0\_LUMA\_Y1  
VD2\_IF0\_CHROMA\_X1 0x3229  
Same as VD1\_IF0\_CHROMA\_X1  
VD2\_IF0\_CHROMA\_Y1 0x327A  
Same as VD1\_IF0\_CHROMA\_Y1  
VD2\_IF0\_RPT\_LOOP 0x322B  
Same as VD1\_IF0\_RPT\_LOOP  
VD2\_IF0\_LUMA0\_RPT\_PAT 0x322C  
Same as VD1\_IF0\_LUMA0\_RPT\_PAT  
VD2\_IF0\_CHROMA0\_RPT\_PAT 0x322D  
Same as VD1\_IF0\_CHROMA0\_RPT\_PAT  
VD2\_IF0\_LUMA1\_RPT\_PAT 0x322E  
Same as VD1\_IF0\_LUMA1\_RPT\_PAT  
VD2\_IF0\_CHROMA1\_RPT\_PAT 0x322F  
Same as VD1\_IF0\_CHROMA1\_RPT\_PAT  
VD2\_IF0\_LUMA\_PSEL 0x3230  
Same as VD1\_IF0\_LUMA\_PSEL  
VD2\_IF0\_CHROMA\_PSEL 0x3231  
Same as VD1\_IF0\_CHROMA\_PSEL  
VD2\_IF0\_DUMMY\_PIXEL 0x3232  
Same as VD1\_IF0\_DUMMY\_PIXEL  
VD2\_RANGE\_MAP\_Y 0x323A

Same as VD1\_RANGE\_MAP\_Y

VD2\_RANGE\_MAP\_CB 0x323B

Same as VD1\_RANGE\_MAP\_CB

VD2\_RANGE\_MAP\_CR 0x323C

Same as VD1\_RANGE\_MAP\_CR

VD2\_IF0\_GEN\_REG2 0x323D

Same as VD1\_IF0\_GEN\_REG2

VD2\_IF0\_GEN\_REG3 0x3236

Same as VD1\_IF0\_GEN\_REG3

**Table 9-1178 VIU\_VD2\_FMT\_CTRL 0x3238**

Bit(s)	R/W	Default	Description
31	R/W	0	gate_clk_en. 0=No clock gating, free-running; 1=Enable clock gating for power saving.
30	R/W	0	soft_rst. If true, reset formatters.
28	R/W	0	if true, horizontal formatter use repeating to generate pixel, otherwise use bilinear interpolation
27-24	R/W	0	horizontal formatter initial phase
23	R/W	0	horizontal formatter repeat pixel 0 enable
22-21	R/W	0	horizontal Y/C ratio, 00: 1:1, 01: 2:1, 10: 4:1
20	R/W	0	horizontal formatter enable
19	R/W	0	if true, always use phase0 while vertical formatter, meaning always repeat data, no interpolation
18	R/W	0	if true, disable vertical formatter chroma repeat last line
17	R/W	0	vertical formatter dont need repeat line on phase0, 1: enable, 0: disable
16	R/W	0	vertical formatter repeat line 0 enable
15-12	R/W	0	vertical formatter skip line num at the beginning
11-8	R/W	0	vertical formatter initial phase
7-1	R/W	0	vertical formatter phase step (3.4)
0	R/W	0	vertical formatter enable

**Table 9-1179 VIU\_VD2\_FMT\_W 0x3239**

Bit(s)	R/W	Default	Description
27-16	R/W	0	horizontal formatter width
11-0	R/W	0	vertical formatter width



### 9.2.3.19 Osd\_blend Registers

Table 9-1180 VIU\_OSD\_BLEND\_CTRL 0x39b0

Bit(s)	R/W	Default	Description
31:29	R/W	0x0	hold_lines : //unsigned , default = 3'h0, hold_lines(line) after go_field ,module active
28:27	R/W	0x3	blend2_premult_en : //unsigned , default = 2'h3, blend2 input premult label 1:premult input 0:unpremult input
26	R/W	0x1	din0_byp_blend : //unsigned , default = 1'h1, blend_din0 bypass to dout0 1:bypass 0:blend_din0 input to blend0
25	R/W	0x1	din2_osd_sel : //unsigned , default = 1'h1, blend1_dout bypass to blend2 0:blend1_dout to blend2 1:blend1_dout to dout1
24	R/W	0x1	din3_osd_sel : //unsigned , default = 1'h1, blend1_din3 bypass to dout1 1:bypass 0:blend_din3 input to blend1
23:20	R/W	0x5	blend_din_en : //unsigned , default = 4'h5, blend enable bits ,four bits for four input
19:16	R/W	0x0	din_premult_en : //unsigned , default = 4'h0, input premult label bits,four bits for four input
15:0	R/W	0x2341	din_reorder_sel : //unsigned , default = 16'h2341,osd_blend input reorder exp : din_reorder_sel[3:0] = 1 ,blend_din0 select osd1 din_reorder_sel [3:0] = 2 ,blend_din0 select osd2 din_reorder_sel [3:0] = 3 ,blend_din0 select osd3 din_reorder_sel [3:0] = else,blend_din0 no src din_reorder_sel [7:4] fot blend_din1

Table 9-1181 VIU\_OSD\_BLEND\_CTRL1 0x39c0

Bit(s)	R/W	Default	Description
17:16	R/W	0	reg_alp1_mapping_mode : //unsigned , default = 0 , osd_blend dout1 alpha divisor mode 8bit alpha:set 0 9bit alpha:set 3
14:13	R/W	0	reg_div1_gclk_en : //unsigned , default = 0 , osd_blend dout1 alpha divisor gclk_en
12	R/W	0	reg_div1_alpha_en : //unsigned , default = 0 , osd_blend dout1 alpha divisor gclk_en enable
9:8	R/W	0	osdbld_gclk_ctrl : //unsigned , default = 0 , osdbld_gclk_ctrl
5:4	R/W	0	reg_alp_mapping_mode : //unsigned , default = 0 , osd_blend dout0 alpha divisor mode 8bit alpha:set 0 9bit alpha:set 3
2:1	R/W	0	reg_div_gclk_en : //unsigned , default = 0 , osd_blend dout0 alpha divisor gclk_en
0	R/W	0	reg_div_alpha_en : //unsigned , default = 0 , osd_blend dout0 alpha divisor gclk_en enable

Table 9-1182 VIU\_OSD\_BLEND\_DIN0\_SCOPE\_H 0x39b1

Bit(s)	R/W	Default	Description
28:16	R/W	0x2d0	bld_din0_h_end : ///unsigned , default = 13'h2d0,blend_din0 h_end
12:0	R/W	0x0	bld_din0_h_start : ///unsigned , default = 13'h0 ,blend_din0 h_start

**Table 9-1183 VIU\_OSD\_BLEND\_DIN0\_SCOPE\_V 0x39b2**

Bit(s)	R/W	Default	Description
28:16	R/W	0x1e0	bld_din0_v_end : ///unsigned , default = 13'h1e0,bld_din0 v_end
12:0	R/W	0x0	bld_din0_v_start : ///unsigned , default = 13'h0,bld_din0 v_start

**Table 9-1184 VIU\_OSD\_BLEND\_DIN1\_SCOPE\_H 0x39b3**

Bit(s)	R/W	Default	Description
28:16	R/W	0x2d0	bld_din1_h_end : ///unsigned , default = 13'h2d0
12:0	R/W	0x0	bld_din1_h_start : ///unsigned , default = 13'h0

**Table 9-1185 VIU\_OSD\_BLEND\_DIN1\_SCOPE\_V 0x39b4**

Bit(s)	R/W	Default	Description
28:16	R/W	0x1e0	bld_din1_v_end : ///unsigned , default = 13'h1e0
12:0	R/W	0x0	bld_din1_v_start : ///unsigned , default = 13'h0

**Table 9-1186 VIU\_OSD\_BLEND\_DIN2\_SCOPE\_H 0x39b5**

Bit(s)	R/W	Default	Description
28:16	R/W	0x2d0	bld_din2_h_end : ///unsigned , default = 13'h2d0
12:0	R/W	0x0	bld_din2_h_start : ///unsigned , default = 13'h0

**Table 9-1187 VIU\_OSD\_BLEND\_DIN2\_SCOPE\_V 0x39b6**

Bit(s)	R/W	Default	Description
28:16	R/W	0x1e0	bld_din2_v_end : ///unsigned , default = 13'h1e0
12:0	R/W	0x0	bld_din2_v_start : ///unsigned , default = 13'h0

**Table 9-1188 VIU\_OSD\_BLEND\_DIN3\_SCOPE\_H 0x39b7**

Bit(s)	R/W	Default	Description
28:16	R/W	0x2d0	bld_din3_h_end : ///unsigned , default = 13'h2d0
12:0	R/W	0x0	bld_din3_h_start : ///unsigned , default = 13'h0

**Table 9-1189 VIU\_OSD\_BLEND\_DIN3\_SCOPE\_V 0x39b8**

Bit(s)	R/W	Default	Description
28:16	R/W	0x1e0	bld_din3_v_end : ///unsigned , default = 13'h1e0
12:0	R/W	0x0	bld_din3_v_start : ///unsigned , default = 13'h0

**Table 9-1190 VIU\_OSD\_BLEND\_DUMMY\_DATA0 0x39b9**

Bit(s)	R/W	Default	Description
23:16	R/W	0x00	blend0_dummy_data_y : //unsigned , default = 8'h00
15:8	R/W	0x80	blend0_dummy_data_cb : //unsigned , default = 8'h80
7:0	R/W	0x80	blend0_dummy_data_cr : //unsigned , default = 8'h80

**Table 9-1191 VIU\_OSD\_BLEND\_DUMMY\_ALPHA 0x39ba**

Bit(s)	R/W	Default	Description
28:20	R/W	0x0	blend0_dummy_alpha : //unsigned , default = 9'h0
19:11	R/W	0x0	blend1_dummy_alpha : //unsigned , default = 9'h0
8:0	R/W	0x0	blend2_dummy_alpha : //unsigned , default = 9'h0

**Table 9-1192 VIU\_OSD\_BLEND\_BLEND0\_SIZE 0x39bb**

Bit(s)	R/W	Default	Description
28:16	R/W	0x1e0	blend0_vsize : //unsigned , default = 13'h1e0,blend0_vsize
12:0	R/W	0x2d0	blend0_hsize : //unsigned , default = 13'h2d0,blend0_hsize

**Table 9-1193 VIU\_OSD\_BLEND\_BLEND1\_SIZE 0x39bc**

Bit(s)	R/W	Default	Description
28:16	R/W	0x1e0	blend1_vsize : //unsigned , default = 13'h1e0
12:0	R/W	0x2d0	blend1_hsize : //unsigned , default = 13'h2d0

### 9.2.3.20 Pre/Post Blend Registers

**Table 9-1194 VPP\_PRE\_BLEND\_CTRL 0x3960**

Bit(s)	R/W	Default	Description
27:20	R/W	0x4	hold_lines : //unsigned , default = 8'h4,blend work after hold_lines line after go_field
1:0	R/W	0x1	gclk_ctrl : //unsigned , default = 16'h1,gating ctrl

**Table 9-1195 VPP\_PRE\_BLEND\_BLEND\_DUMMY\_DATA 0x3961**

Bit(s)	R/W	Default	Description
23:16	R/W	0x0	blend0_dummy_data_y : //unsigned , default = 8'h0,blend dummy data
15:8	R/W	0x80	blend0_dummy_data_cb : //unsigned , default = 8'h80,blend dummy data
7:0	R/W	0x80	blend0_dummy_data_cr : //unsigned , default = 8'h80 ,blend dummy data

**Table 9-1196 VPP\_PRE\_BLEND\_DUMMY\_ALPHA 0x3962**

Bit(s)	R/W	Default	Description
28:20	R/W	0x0	blend0_dummy_alpha : //unsigned , default = 9'h0,blend dummy alpha
19:11	R/W	0x0	blend1_dummy_alpha : //unsigned , default = 9'h0,blend dummy alpha
8:0	R/W	0x0	blend2_dummy_alpha : //unsigned , default = 9'h0,blend dummy alpha

**Table 9-1197 VPP\_PRE\_BLEND2\_RO\_CURRENT\_XY 0x3963**

Bit(s)	R/W	Default	Description
28:16	R.O	0x0	ro_current_x : //unsigned , default = 32'h0,blend out x point
12:0	R.O	0x0	ro_current_y : //unsigned , default = 32'h0,blend out x point

**Table 9-1198 VPP\_POST\_PRE\_BLEND\_CTRL 0x3967**

Bit(s)	R/W	Default	Description
27:20	R/W	0x4	hold_lines : //unsigned , default = 8'h4,blend work after hold_lines line after go_field
1:0	R/W	0x1	gclk_ctrl : //unsigned , default = 16'h1,gating ctrl

**Table 9-1199 VPP\_POST\_BLEND\_BLEND\_DUMMY\_DATA 0x3968**

Bit(s)	R/W	Default	Description
23:16	R/W	0x0	blend0_dummy_data_y : //unsigned , default = 8'h0,blend dummy data
15:8	R/W	0x80	blend0_dummy_data_cb : //unsigned , default = 8'h80,blend dummy data
7:0	R/W	0x80	blend0_dummy_data_cr : //unsigned , default = 8'h80 ,blend dummy data

**Table 9-1200 VPP\_POST-BLEND\_DUMMY\_ALPHA 0x3969**

Bit(s)	R/W	Default	Description
28:20	R/W	0x0	blend0_dummy_alpha : //unsigned , default = 9'h0,blend dummy alpha
19:11	R/W	0x0	blend1_dummy_alpha : //unsigned , default = 9'h0,blend dummy alpha
8:0	R/W	0x0	blend2_dummy_alpha : //unsigned , default = 9'h0,blend dummy alpha

**Table 9-1201 VPP\_POST\_BLEND2\_RO\_CURRENT\_XY 0x396a**

Bit(s)	R/W	Default	Description
28:16	R.O	0x0	ro_current_x : //unsigned , default = 32'h0,blend out x point
12:0	R.O	0x0	ro_current_y : //unsigned , default = 32'h0,blend out x point

### 9.2.3.21 VPU AFBC Registers

**Table 9-1202 AFBC\_ENABLE 0x1ae0**

Bit(s)	R/W	Default	Description
8	R/W	0	dec_enable : unsigned , default = 0
0	R/W	0	frm_start : unsigned , default = 0

**Table 9-1203 AFBC\_MODE 0x1ae1**

Bit(s)	R/W	Default	Description
31	R/W	0x0	soft_reset : the use as go_field
28	R/W	0x0	Blk_mem_mode : Default = 0, body space save mode when blk_mem_mode ==1
27:26	R/W	0	rev_mode : uns, default = 0 , reverse mode
25:24	R/W	3	mif_urgent : uns, default = 3 , info mif and data mif urgent
22:16	R/W	0x0	hold_line_num :
15:14	R/W	1	burst_len : uns, default = 1, 0: burst1 1:burst2 2:burst4
13:8	R/W	0	compbits_yuv : uns, default = 0 , bit 1:0,: y component bitwidth : 00-8bit 01-9bit 10-10bit bit 3:2,: u component bitwidth : 00-8bit 01-9bit 10-10bit bit 5:4,: v component bitwidth : 00-8bit 01-9bit 10-10bit
7:6	R/W	0	vert_skip_y : uns, default = 0 , luma vert skip mode : 00-y0y1, 01-y0, 10-y1, 11-(y0+y1)/2
5:4	R/W	0	horz_skip_y : uns, default = 0 , luma horz skip mode : 00-y0y1, 01-y0, 10-y1, 11-(y0+y1)/2
3:2	R/W	0	vert_skip_uv : uns, default = 0 , chroma vert skip mode : 00-y0y1, 01-y0, 10-y1, 11-(y0+y1)/2
1:0	R/W	0	horz_skip_uv : uns, default = 0 , chroma horz skip mode : 00-y0y1, 01-y0, 10-y1, 11-(y0+y1)/2

**Table 9-1204 AFBC\_SIZE\_IN 0x1ae2**

Bit(s)	R/W	Default	Description
28:16	R/W	1920	hsize_in : uns, default = 1920 , pic horz size in unit: pixel
12:0	R/W	1080	vsize_in : uns, default = 1080 , pic vert size in unit: pixel

**Table 9-1205 AFBC\_DEC\_DEF\_COLOR 0x1ae3**

Bit(s)	R/W	Default	Description
29:20	R/W	0	def_color_y : uns, default = 0, afbc dec y default setting value
19:10	R/W	0	def_color_u : uns, default = 0, afbc dec u default setting value
9: 0	R/W	0	def_color_v : uns, default = 0, afbc dec v default setting value

**Table 9-1206 AFBC\_CONV\_CTRL 0x1ae4**

Bit(s)	R/W	Default	Description
11:0	R/W	256	conv_lbuf_len : uns, default = 256, unit=16 pixel need to set = 2^n

**Table 9-1207 AFBC\_LBUF\_DEPTH 0x1ae5**

Bit(s)	R/W	Default	Description
27:16	R/W	128	dec_lbuf_depth : uns, default = 128; // unit= 8 pixel
11:0	R/W	128	mif_lbuf_depth : uns, default = 128;

**Table 9-1208 AFBC\_HEAD\_BADDR 0x1ae6**

Bit(s)	R/W	Default	Description
31:0	R/W	0x0	mif_info_baddr : uns, default = 32'h0;

**Table 9-1209 AFBC\_BODY\_BADDR 0x1ae7**

Bit(s)	R/W	Default	Description
31:0	R/W	0x0001_0000	mif_data_baddr : uns, default = 32'h0001_0000;

**Table 9-1210 AFBC\_SIZE\_OUT 0x1ae8**

Bit(s)	R/W	Default	Description
31:29	R/W	0	reserved
28:16	R/W	1920	hszie_out: uns, default = 1920 ; // unit: 1 pixel
15:13	R/W	0	reserved
12:0	R/W	1080	Vsize_out : uns, default = 1080 ; // unit: 1 pixel

**Table 9-1211 AFBC\_OUT\_YSCOPE 0x1ae9**

Bit(s)	R/W	Default	Description
28:16	R/W	0	out_vert_bgn : uns, default = 0 ; // unit: 1 pixel
12:0	R/W	1079	out_vert_end : uns, default = 1079 ; // unit: 1 pixel

**Table 9-1212 AFBC\_STAT 0x1aea**

Bit(s)	R/W	Default	Description
0	RO	0x0	frm_end_stat : uns, frame end status

**Table 9-1213 AFBC\_VD\_CFMT\_CTRL 0x1aeb**

Bit(s)	R/W	Default	Description
31	R/W	0x0	it : true, disable clock, otherwise enable clock
30	R/W	0x0	soft : rst bit
28	R/W	0x0	if : true, horizontal formatter use repeating to generate pixel, otherwise use bilinear interpolation
27:24	R/W	0x0	horizontal : formatter initial phase
23	R/W	0x0	horizontal : formatter repeat pixel 0 enable
22:21	R/W	0x0	horizontal : Y/C ratio, 00: 1:1, 01: 2:1, 10: 4:1
20	R/W	0x0	horizontal : formatter enable
19	R/W	0x0	if : true, always use phase0 while vertical formatter, meaning always repeat data, no interpolation
18	R/W	0x0	if : true, disable vertical formatter chroma repeat last line
17	R/W	0x0	vertical : formatter dont need repeat line on phase0, 1: enable, 0: disable
16	R/W	0x0	vertical : formatter repeat line 0 enable
15:12	R/W	0x0	vertical : formatter skip line num at the beginning
11:8	R/W	0x0	vertical : formatter initial phase
7:1	R/W	0x0	vertical : formatter phase step (3.4)
0	R/W	0x0	vertical : formatter enable

**Table 9-1214 AFBC\_VD\_CFMT\_W 0x1aec**

Bit(s)	R/W	Default	Description
27:16	R/W	0x0	horizontal : formatter width
11:0	R/W	0x0	vertical : formatter width

**Table 9-1215 AFBC\_MIF\_HOR\_SCOPE 0x1aed**

Bit(s)	R/W	Default	Description
25:16	R/W	0	mif_blk_bgn_h : uns, default = 0 ; // unit: 32 pixel/block hor
9: 0	R/W	59	mif_blk_end_h : uns, default = 59 ; // unit: 32 pixel/block hor

**Table 9-1216 AFBC\_MIF\_VER\_SCOPE 0x1aee**

Bit(s)	R/W	Default	Description
27:16	R/W	0	mif_blk_bgn_v : uns, default = 0 ; // unit: 32 pixel/block ver
11: 0	R/W	269	mif_blk_end_v : uns, default = 269; // unit: 32 pixel/block ver

Table 9-1217 AFBC\_PIXEL\_HOR\_SCOPE 0x1aef

Bit(s)	R/W	Default	Description
28:16	R/W	0	dec_pixel_bgn_h : uns, default = 0 ; // unit: pixel
12: 0	R/W	1919	dec_pixel_end_h : uns, default = 1919 ; // unit: pixel

Table 9-1218 AFBC\_PIXEL\_VER\_SCOPE 0x1af0

Bit(s)	R/W	Default	Description
28:16	R/W	0	dec_pixel_bgn_v : uns, default = 0 ; // unit: pixel
12: 0	R/W	1079	dec_pixel_end_v : uns, default = 1079 ; // unit: pixel

Table 9-1219 AFBC\_VD\_CFMT\_H 0x1af1

Bit(s)	R/W	Default	Description
12:0	R/W	0x0	vertical : formatter height

Table 9-1220 VD2\_AFBC\_ENABLE 0x3180

Bit(s)	R/W	Default	Description
8	R/W	0	dec_enable : unsigned , default = 0
0	R/W	0	frm_start : unsigned , default = 0

Table 9-1221 VD2\_AFBC\_MODE 0x3181

Bit(s)	R/W	Default	Description
31	R/W	0x0	soft_reset : the use as go_field
28	R/W	0x0	Blk_mem_mode : Default = 0, body space save mode when blk_mem_mode == 1
27:26	R/W	0	rev_mode : uns, default = 0 , reverse mode
25:24	R/W	3	mif_urgent : uns, default = 3 , info mif and data mif urgent
22:16	R/W	0x0	hold_line_num :
15:14	R/W	1	burst_len : uns, default = 1, 0: burst1 1:burst2 2:burst4
13:8	R/W	0	compbits_yuv : uns, default = 0 , bit 1:0,: y component bitwidth : 00-8bit 01-9bit 10-10bit bit 3:2,: u component bitwidth : 00-8bit 01-9bit 10-10bit bit 5:4,: v component bitwidth : 00-8bit 01-9bit 10-10bit
7:6	R/W	0	vert_skip_y : uns, default = 0 , luma vert skip mode : 00-y0y1, 01-y0, 10-y1, 11-(y0+y1)/2
5:4	R/W	0	horz_skip_y : uns, default = 0 , luma horz skip mode : 00-y0y1, 01-y0, 10-y1, 11-(y0+y1)/2
3:2	R/W	0	vert_skip_uv : uns, default = 0 , chroma vert skip mode : 00-y0y1, 01-y0, 10-y1, 11-(y0+y1)/2
1:0	R/W	0	horz_skip_uv : uns, default = 0 , chroma horz skip mode : 00-y0y1, 01-y0, 10-y1, 11-(y0+y1)/2



**Table 9-1222 VD2\_AFBC\_SIZE\_IN 0x3182**

Bit(s)	R/W	Default	Description
28:16	R/W	1920	hsize_in : uns, default = 1920 , pic horz size in unit: pixel
12:0	R/W	1080	vsize_in : uns, default = 1080 , pic vert size in unit: pixel

**Table 9-1223 VD2\_AFBC\_DEC\_DEF\_COLOR 0x3183**

Bit(s)	R/W	Default	Description
29:20	R/W	0	def_color_y : uns, default = 0, afbc dec y default setting value
19:10	R/W	0	def_color_u : uns, default = 0, afbc dec u default setting value
9: 0	R/W	0	def_color_v : uns, default = 0, afbc dec v default setting value

**Table 9-1224 VD2\_AFBC\_CONV\_CTRL 0x3184**

Bit(s)	R/W	Default	Description
11: 0	R/W	256	conv_lbuf_len : uns, default = 256, unit=16 pixel need to set = 2^n

**Table 9-1225 VD2\_AFBC\_LBUF\_DEPTH 0x3185**

Bit(s)	R/W	Default	Description
27:16	R/W	128	dec_lbuf_depth : uns, default = 128; // unit= 8 pixel
11:0	R/W	128	mif_lbuf_depth : uns, default = 128;

**Table 9-1226 VD2\_AFBC\_HEAD\_BADDR 0x3186**

Bit(s)	R/W	Default	Description
31:0	R/W	0x0	mif_info_baddr : uns, default = 32'h0;

**Table 9-1227 VD2\_AFBC\_BODY\_BADDR 0x3187**

Bit(s)	R/W	Default	Description
31:0	R/W	0x0001_0000	mif_data_baddr : uns, default = 32'h0001_0000;

**Table 9-1228 VD2\_AFBC\_OUT\_XSCOPE 0x3188**

Bit(s)	R/W	Default	Description
28:16	R/W	0	out_horz_bgn : uns, default = 0 ; // unit: 1 pixel
12:0	R/W	1919	out_horz_end : uns, default = 1919 ; // unit: 1 pixel

Table 9-1229 VD2\_AFBC\_OUT\_YSCOPE 0x3189

Bit(s)	R/W	Default	Description
28:16	R/W	0	out_vert_bgn : uns, default = 0 ; // unit: 1 pixel
12:0	R/W	1079	out_vert_end : uns, default = 1079 ; // unit: 1 pixel

Table 9-1230 VD2\_AFBC\_STAT 0x318A

Bit(s)	R/W	Default	Description
0	RO	0x0	frm_end_stat : uns, frame end status

Table 9-1231 VD2\_AFBC\_VD\_CFMT\_CTRL 0x318b

Bit(s)	R/W	Default	Description
31	R/W	0x0	it : true, disable clock, otherwise enable clock
30	R/W	0x0	soft : rst bit
28	R/W	0x0	if : true, horizontal formatter use repeating to generate pixel, otherwise use bilinear interpolation
27:24	R/W	0x0	horizontal : formatter initial phase
23	R/W	0x0	horizontal : formatter repeat pixel 0 enable
22:21	R/W	0x0	horizontal : Y/C ratio, 00: 1:1, 01: 2:1, 10: 4:1
20	R/W	0x0	horizontal : formatter enable
19	R/W	0x0	if : true, always use phase0 while vertical formater, meaning always repeat data, no interpolation
18	R/W	0x0	if : true, disable vertical formatter chroma repeat last line
17	R/W	0x0	vertical : formatter dont need repeat line on phase0, 1: enable, 0: disable
16	R/W	0x0	vertical : formatter repeat line 0 enable
15:12	R/W	0x0	vertical : formatter skip line num at the beginning
11:8	R/W	0x0	vertical : formatter initial phase
7:1	R/W	0x0	vertical : formatter phase step (3.4)
0	R/W	0x0	vertical : formatter enable

Table 9-1232 VD2\_AFBC\_VD\_CFMT\_W 0x318c

Bit(s)	R/W	Default	Description
27:16	R/W	0x0	horizontal : formatter width
11:0	R/W	0x0	vertical : formatter width

Table 9-1233 VD2\_AFBC\_MIF\_HOR\_SCOPE 0x318d

Bit(s)	R/W	Default	Description
25:16	R/W	0	mif_blk_bgn_h : uns, default = 0 ; // unit: 32 pixel/block hor
9: 0	R/W	59	mif_blk_end_h : uns, default = 59 ; // unit: 32 pixel/block hor

Table 9-1234 VD2\_AFBC\_MIF\_VER\_SCOPE 0x318e

Bit(s)	R/W	Default	Description
27:16	R/W	0	mif_blk_bgn_v : uns, default = 0 ; // unit: 32 pixel/block ver
11: 0	R/W	269	mif_blk_end_v : uns, default = 269 ; // unit: 32 pixel/block ver

Table 9-1235 VD2\_AFBC\_PIXEL\_HOR\_SCOPE 0x318f

Bit(s)	R/W	Default	Description
28:16	R/W	0	dec_pixel_bgn_h : uns, default = 0 ; // unit: pixel
12: 0	R/W	1919	dec_pixel_end_h : uns, default = 1919 ; // unit: pixel

Table 9-1236 VD2\_AFBC\_PIXEL\_VER\_SCOPE 0x3190

Bit(s)	R/W	Default	Description
28:16	R/W	0	dec_pixel_bgn_v : uns, default = 0 ; // unit: pixel
12: 0	R/W	1079	dec_pixel_end_v : uns, default = 1079 ; // unit: pixel

Table 9-1237 VD2\_AFBC\_VD\_CFMT\_H 0x3191

Bit(s)	R/W	Default	Description
12:0	R/W	0x0	vertical : formatter height

### 9.2.3.22 VPP Registers

Table 9-1238 VPP\_DUMMY\_DATA 0x1d00

Bit(s)	R/W	Default	Description
29:20	R/W	0	VD1_SC_Y : // unsigned , default = 0x10,dummy data used in the VD1 scaler,according VPP_DOLBY_CTRL[17] 1:set 8bit value 2:set 10bit value
19:10	R/W	0	VD1_SC_CB : // unsigned , default = 0x80,dummy data used in the VD1 scaler,according VPP_DOLBY_CTRL[17] 1:set 8bit value 2:set 10bit value
9 :0	R/W	0	VD1_SC_CR : // unsigned , default = 0x80,dummy data used in the VD1 scaler,according VPP_DOLBY_CTRL[17] 1:set 8bit value 2:set 10bit value

**Table 9-1239 VPP\_LINE\_IN\_LENGTH 0x1d01**

Bit(s)	R/W	Default	Description
13:0	R/W	14	line_in_length : // unsigned , default = 14'd1920,VD1 scaler input hsize

**Table 9-1240 VPP\_PIC\_IN\_HEIGHT 0x1d02**

Bit(s)	R/W	Default	Description
12:0	R/W	0x1fff	line_in_height : // unsigned , default = 13'h1fff,VD1 scaler input vsize

**Table 9-1241 VPP\_PREBLEND\_VD1\_H\_START\_END 0x1d1a**

Bit(s)	R/W	Default	Description
28:16	R/W	0	start : //unsigned , default = 0x0000 ,preblend video1 horizontal start
12:0	R/W	0	end : //unsigned , default = 0x077f ,preblend video1 horizontal end

**Table 9-1242 VPP\_PREBLEND\_VD1\_V\_START\_END 0x1d1b**

Bit(s)	R/W	Default	Description
28:16	R/W	0	start : //unsigned , default = 0x0000 ,preblend video1 vertical start
12:0	R/W	0	end : //unsigned , default = 0x0437 ,preblend video1 vertical end

**Table 9-1243 VPP\_POSTBLEND\_VD1\_H\_START\_END 0x1d1c**

Bit(s)	R/W	Default	Description
28:16	R/W	0	start : //unsigned , default = 0x0000 ,postblend video1 horizontal start
12:0	R/W	0	end : //unsigned , default = 0x077f ,postblend video1 horizontal end

**Table 9-1244 VPP\_POSTBLEND\_VD1\_V\_START\_END 0x1d1d**

Bit(s)	R/W	Default	Description
31:29	/	/	/
28:16	R/W	0	//unsigned , default = 0x0000 ,postblend video1 vertical start Bit
15:13	/	/	/
12:0		0x077f	//unsigned , default = 0x077f ,postblend video1 vertical end

**Table 9-1245 VPP\_BLEND\_VD2\_H\_START\_END 0x1d1e**

Bit(s)	R/W	Default	Description
28:16	R/W	0	start : //unsigned , default = 0x0000 ,preblend/postblend video2 horizontal start
12:0	R/W	0	end : //unsigned , default = 0x077f ,preblend/postblend video2 horizontal end

**Table 9-1246 VPP\_BLEND\_VD2\_V\_START\_END 0x1d1f**

Bit(s)	R/W	Default	Description
28:16	R/W	0	start : //unsigned , default = 0x0000 ,preblend/postblend video2 vertical start
12:0	R/W	0	end : //unsigned , default = 0x077f ,preblend/postblend video2 vertical end

**Table 9-1247 VPP\_PREBLEND\_H\_SIZE 0x1d20**

Bit(s)	R/W	Default	Description
29:16	R/W	14	prebld_v_size : //unsigned , default = 14'd1080 ,preblend output vsize
13:0	R/W	14	prebld_h_size : //unsigned , default = 14'd1920 ,preblend output hsize

**Table 9-1248 VPP\_POSTBLEND\_H\_SIZE 0x1d21**

Bit(s)	R/W	Default	Description
29:16	R/W	14	postbld_v_size : //unsigned , default = 14'd1080 ,postblend output vsize
13:0	R/W	14	postbld_h_size : //unsigned , default = 14'd1920 ,postblend output hsize

**Table 9-1249 VPP hold lines VPP\_HOLD\_LINES 0x1d22**

Bit(s)	R/W	Default	Description
15:8	R/W	4	prebld_hold_lines : //unsigned , default = 4,preblend hold lines
7:0	R/W	4	postbld_hold_lines : //unsigned , default = 4,postblend hold lines

**Table 9-1250 VPP\_MISC 0x1d26**

Bit(s)	R/W	Default	Description
29	R/W	0	vpp_vks_en : //unsigned , default = 0 , vkstone enable
28	R/W	0	color_manage_en : //unsigned , default = 0 , color management enable
27	R/W	0	vd2_use_viu2_out_en : //unsigned , default = 0 , if true, vd2 use viu2 output as the input, otherwise use normal vd2 from memory
26:18	R/W	0	vd2 : alpha //unsigned , default = 0 , video 2 prebld/postbld alpha
7	R/W	1	postbld_en : //unsigned , default = 1 , postblend module enable
6	R/W	0	prebld_en : //unsigned , default = 0 , preblend module enable
3	R/W	0	sr4c1_path_sel : //unsigned , default = 0 , choose sr0 position 1:sr0 bettween dnlp & CM 0:sr0 bettween position after postblend
2	R/W	0	disable_rst_affio : //unsigned , default = 0 , if true, disable resetting async fifo every vsync, otherwise every vsync the aync fifo will be reseted.
1	R/W	0	sr4c0_path_sel : //unsigned , default = 0 , choose sr0 position 1:sr0 bettween prebld & vd1_scale 0:sr0 bettween position after dnlp

**Table 9-1251 VPP\_OFIFO\_SIZE 0x1d27**

Bit(s)	R/W	Default	Description
31:20	R/W	0	ofifo_line_lenm1 : //unsigned , default = 0xff , ofifo line length minus 1
19	R/W	0	vs_ctrl : //unsigned , default = 0 , if true invert input vs
18	R/W	0	hs_ctrl : //unsigned , default = 0 , if true invert input hs
17	R/W	0	force_top_bot_field_en : //unsigned , default = 0 , force top/bottom field, enable
16	R/W	0	fforce_top_bot_field : //unsigned , default = 0 , force top/bottom field, 0: top, 1: bottom
15	R/W	0	force_go_field : //unsigned , default = 0 , force one go_field, one pluse, write only
14	R/W	0	force_go_line : //unsigned , default = 0 , force one go_line, one pluse, write only
13:0	R/W	0	ofifo_size : //unsigned , default = 0x1000 , ofifo size (actually only bit 13:1 is valid), always even number ,max 4096

**Table 9-1252 VPP\_FIFO\_STATUS 0x1d28**

Bit(s)	R/W	Default	Description
29:25	R.O	0	ro_sco_ff_buf_count : //unsigned , default = 0,current scale out fifo counter
24:14	R.O	0	ro_afifo_count : //unsigned , default = 0,current enc afifo counter
13:1	R.O	0	ro_ofifo_buf_count : //unsigned , default = 0,current vpp line fifo ofifo counter

**Table 9-1253 VPP\_MATRIX\_PROBE\_COLOR 0x1d5c**

Bit(s)	R/W	Default	Description
31:24	R.O	0	ro_probe_y_l : //unsigned , default = 0,low 8 bits of component 0
23:12	R.O	0	ro_probe_cr : //unsigned , default = 0,component 1
11:0	R.O	0	ro_probe_cb : //unsigned , default = 0,component 2

**Table 9-1254 VPP\_MATRIX\_PROBE\_COLOR1 0x1dd7**

Bit(s)	R/W	Default	Description
31	R.O	0x0	ro_probe_pix_v : //it means this probe is valid in the last field/frame
3:0	R.O	0	ro_probe_y_h : //unsigned , default = 0,high 4 bits of component 0

**Table 9-1255 VPP\_MATRIX\_HL\_COLOR 0x1d5d**

Bit(s)	R/W	Default	Description
23:16	R/W	0	hl_y : //unsigned , default = 0,component 0
15:8	R/W	0	hl_cb : //unsigned , default = 0,component 1
7:0	R/W	0	hl_cr : //unsigned , default = 0,component 2

**Table 9-1256 VPP\_MATRIX\_PROBE\_POS 0x1d5e**

Bit(s)	R/W	Default	Description
28:16	R/W	0	probe_x : //unsigned , default = 0,probe x, postion
12:0	R/W	0	probe_y : //unsigned , default = 0,probe y, position

**Table 9-1257 VPP\_MATRIX\_CTRL 0x1d5f**

Bit(s)	R/W	Default	Description
16	R/W	0	highlight_en : //unsigned , default = 0, highlight enable
15	R/W	0	probe_post : //unsigned , default = 0, if true, probe pixel data after matrix, otherwise probe pixel data before matrix
14:10	R/W	0	probel_sel : //unsigned , default = 0, active when VIU_SECURE_REG[9] high, probel sel : 5'b00001 :vadj1 5'b00010 :vadj2 5'b00100 :osd2 5'b01000 :postbld 5'b10000 :osd1

**Table 9-1258 VPP\_GAINOFF\_CTRL0 0x1d6a**

Bit(s)	R/W	Default	Description
31	R/W	0	enable : //unsigned , default = 0, gainoff module enable
30	R/W	0	enable_sel : //unsigned , default = 0, gainoff module enable sync sel
26:16	R/W	0	gain0 : //unsigned , default = 0, gainoff module gain0
10:0	R/W	0	gain1 : //unsigned , default = 0, gainoff module gain1

**Table 9-1259 VPP\_GAINOFF\_CTRL1 0x1d6b**

Bit(s)	R/W	Default	Description
26:16	R/W	0	gain2 : //unsigned , default = 0, gainoff module gain2
12:0	R/W	0	offset0 : //signed , default = 0, gainoff module offset0

**Table 9-1260 VPP\_GAINOFF\_CTRL2 0x1d6c**

Bit(s)	R/W	Default	Description
28:16	R/W	0	offset1 : //signed ,bitwidth is DW+1,DW is the chip path data width, default = 0, gainoff module offset1
12:0	R/W	0	offset2 : //signed , bitwidth is DW+1,DW is the chip path data width,default = 0, gainoff module offset2

**Table 9-1261 VPP\_GAINOFF\_CTRL3 0x1d6d**

Bit(s)	R/W	Default	Description
28:16	R/W	0	pre_offset0 : //signed , bitwidth is DW+1,DW is the chip path data width,default = 0, gainoff module pre_offset0
12:0	R/W	0	pre_offset1 : //signed , bitwidth is DW+1,DW is the chip path data width,default = 0, gainoff module pre_offset1

**Table 9-1262 VPP\_GAINOFF\_CTRL4 0x1d6e**

Bit(s)	R/W	Default	Description
12:0	R/W	0	pre_offset2 : //signed , bitwidth is DW+1,DW is the chip path data width,default = 0, gainoff module pre_offset2

**Table 9-1263 VPP\_GAINOFF\_GCLK\_CTRL 0x1d6f**

Bit(s)	R/W	Default	Description
1:0	R/W	0	gainoff_gclk_ctrl : //unsigned , default = 0,gainoff_gclk_ctrl

**Table 9-1264 VPP\_GCLK\_CTRL0 0x1d72**

Bit(s)	R/W	Default	Description
5:4	R/W	0	offo_clk1 : //unsigned , default = 0,gating clock of out linefifo in vpp
3:2	R/W	0	clk0 : //unsigned , default = 0,clk swtich of all vpp module
1	R/W	0	reg_gclk : //unsigned , default = 0,registers gate clk of vpp module

**Table 9-1265 VPP\_GCLK\_CTRL1 0x1d73**

Bit(s)	R/W	Default	Description
27:20	R/W	0	gclk_ctrl_wm : //unsigned , default = 0,gating clock of water_mark
18:15	R/W	0	dolby3_gclk_ctrl : //unsigned , default = 0,gating clock of dolby3
3:0	R/W	0	cm_gclk_ctrl : //unsigned , default = 0,gating clock of color manage

**Table 9-1266 VPP\_MISC1 0x1d76**

Bit(s)	R/W	Default	Description
20:12	R/W	0	vd1_prebld_alpha : //unsigned , default = 0,VD1 alpha for preblend
8:0	R/W	0	vd1_postbld_alpha : //unsigned , default = 0,VD1 alpha for postblend

**Table 9-1267 VPP\_SRSC\_L\_GCLK\_CTRL 0x1d77**

Bit(s)	R/W	Default	Description
15:8	R/W	0	gclk_ctrl_sr1 : //unsigned , default = 0 , gating clock of sr1
7:0	R/W	0	gclk_ctrl_sr0 : //unsigned , default = 0 , gating clock of sr0



**Table 9-1268 VPP\_BLACKEXT\_CTRL 0x1d80**

Bit(s)	R/W	Default	Description
31:24	R/W	0	blackext_start : //unsigned , default = 0 ,blackext_start
23:16	R/W	0	blackext_slope1 : //unsigned , default = 0 ,blackext_slope1
15:8	R/W	0	blackext_midpt : //unsigned , default = 0 ,blackext_midpt
7:0	R/W	0	blackext_slope2 : //unsigned , default = 0 ,blackext_slope2

**Table 9-1269 VPP\_DNLP\_CTRL\_00 0x1d81**

Bit(s)	R/W	Default	Description
31:24	R/W	0	data0 : //unsigned , default = 0 ,bottom of region03 output value
23:16	R/W	0	data1 : //unsigned , default = 0 ,bottom of region02 output value
15:8	R/W	0	data2 : //unsigned , default = 0 ,bottom of region01 output value
7:0	R/W	0	data3 : //unsigned , default = 0 ,bottom of region00 output value

**Table 9-1270 VPP\_DNLP\_CTRL\_01 0x1d82**

Bit(s)	R/W	Default	Description
31:24	R/W	0	data0 : //unsigned , default = 0 ,bottom of region07 output value
23:16	R/W	0	data1 : //unsigned , default = 0 ,bottom of region06 output value
15:8	R/W	0	data2 : //unsigned , default = 0 ,bottom of region05 output value
7:0	R/W	0	data3 : //unsigned , default = 0 ,bottom of region04 output value

**Table 9-1271 VPP\_DNLP\_CTRL\_02 0x1d83**

Bit(s)	R/W	Default	Description
31:24	R/W	0	data0 : //unsigned , default = 0 ,bottom of region11 output value
23:16	R/W	0	data1 : //unsigned , default = 0 ,bottom of region10 output value
15:8	R/W	0	data2 : //unsigned , default = 0 ,bottom of region09 output value
7:0	R/W	0	data3 : //unsigned , default = 0 ,bottom of region08 output value

**Table 9-1272 VPP\_DNLP\_CTRL\_03 0x1d84**

Bit(s)	R/W	Default	Description
31:24	R/W	0	data0 : //unsigned , default = 0 ,bottom of region15 output value
23:16	R/W	0	data1 : //unsigned , default = 0 ,bottom of region14 output value
15:8	R/W	0	data2 : //unsigned , default = 0 ,bottom of region13 output value
7:0	R/W	0	data3 : //unsigned , default = 0 ,bottom of region12 output value

**Table 9-1273 VPP\_DNLP\_CTRL\_04 0x1d85**

Bit(s)	R/W	Default	Description
31:24	R/W	0	data0 : //unsigned , default = 0 ,bottom of region19 output value
23:16	R/W	0	data1 : //unsigned , default = 0 ,bottom of region18 output value
15:8	R/W	0	data2 : //unsigned , default = 0 ,bottom of region17 output value
7:0	R/W	0	data3 : //unsigned , default = 0 ,bottom of region16 output value

**Table 9-1274 VPP\_DNLP\_CTRL\_05 0x1d86**

Bit(s)	R/W	Default	Description
31:24	R/W	0	data0 : //unsigned , default = 0 ,bottom of region23 output value
23:16	R/W	0	data1 : //unsigned , default = 0 ,bottom of region22 output value
15:8	R/W	0	data2 : //unsigned , default = 0 ,bottom of region21 output value
7:0	R/W	0	data3 : //unsigned , default = 0 ,bottom of region20 output value

**Table 9-1275 VPP\_DNLP\_CTRL\_06 0x1d87**

Bit(s)	R/W	Default	Description
31:24	R/W	0	data0 : //unsigned , default = 0 ,bottom of region27 output value
23:16	R/W	0	data1 : //unsigned , default = 0 ,bottom of region26 output value
15:8	R/W	0	data2 : //unsigned , default = 0 ,bottom of region25 output value
7:0	R/W	0	data3 : //unsigned , default = 0 ,bottom of region24 output value

**Table 9-1276 VPP\_DNLP\_CTRL\_07 0x1d88**

Bit(s)	R/W	Default	Description
31:24	R/W	0	data0 : //unsigned , default = 0 ,bottom of region31 output value
23:16	R/W	0	data1 : //unsigned , default = 0 ,bottom of region30 output value
15:8	R/W	0	data2 : //unsigned , default = 0 ,bottom of region29 output value
7:0	R/W	0	data3 : //unsigned , default = 0 ,bottom of region28 output value

**Table 9-1277 VPP\_DNLP\_CTRL\_08 0x1d89**

Bit(s)	R/W	Default	Description
31:24	R/W	0	data0 : //unsigned , default = 0 ,bottom of region35 output value
23:16	R/W	0	data1 : //unsigned , default = 0 ,bottom of region34 output value
15:8	R/W	0	data2 : //unsigned , default = 0 ,bottom of region33 output value
7:0	R/W	0	data3 : //unsigned , default = 0 ,bottom of region32 output value

**Table 9-1278 VPP\_DNLP\_CTRL\_09 0x1d8a**

Bit(s)	R/W	Default	Description
31:24	R/W	0	data0 : //unsigned , default = 0 ,bottom of region39 output value
23:16	R/W	0	data1 : //unsigned , default = 0 ,bottom of region38 output value
15:8	R/W	0	data2 : //unsigned , default = 0 ,bottom of region37 output value
7:0	R/W	0	data3 : //unsigned , default = 0 ,bottom of region36 output value

**Table 9-1279 VPP\_DNLP\_CTRL\_10 0x1d8b**

Bit(s)	R/W	Default	Description
31:24	R/W	0	data0 : //unsigned , default = 0 ,bottom of region43 output value
23:16	R/W	0	data1 : //unsigned , default = 0 ,bottom of region42 output value
15:8	R/W	0	data2 : //unsigned , default = 0 ,bottom of region41 output value
7:0	R/W	0	data3 : //unsigned , default = 0 ,bottom of region40 output value

**Table 9-1280 VPP\_DNLP\_CTRL\_11 0x1d8c**

Bit(s)	R/W	Default	Description
31:24	R/W	0	data0 : //unsigned , default = 0 ,bottom of region47 output value
23:16	R/W	0	data1 : //unsigned , default = 0 ,bottom of region46 output value
15:8	R/W	0	data2 : //unsigned , default = 0 ,bottom of region45 output value
7:0	R/W	0	data3 : //unsigned , default = 0 ,bottom of region44 output value

**Table 9-1281 VPP\_DNLP\_CTRL\_12 0x1d8d**

Bit(s)	R/W	Default	Description
31:24	R/W	0	data0 : //unsigned , default = 0 ,bottom of region51 output value
23:16	R/W	0	data1 : //unsigned , default = 0 ,bottom of region50 output value
15:8	R/W	0	data2 : //unsigned , default = 0 ,bottom of region49 output value
7:0	R/W	0	data3 : //unsigned , default = 0 ,bottom of region48 output value

**Table 9-1282 VPP\_DNLP\_CTRL\_13 0x1d8e**

Bit(s)	R/W	Default	Description
31:24	R/W	0	data0 : //unsigned , default = 0 ,bottom of region55 output value
23:16	R/W	0	data1 : //unsigned , default = 0 ,bottom of region54 output value
15:8	R/W	0	data2 : //unsigned , default = 0 ,bottom of region53 output value
7:0	R/W	0	data3 : //unsigned , default = 0 ,bottom of region52 output value

**Table 9-1283 VPP\_DNLP\_CTRL\_14 0x1d8f**

Bit(s)	R/W	Default	Description
31:24	R/W	0	data0 : //unsigned , default = 0 ,bottom of region59 output value
23:16	R/W	0	data1 : //unsigned , default = 0 ,bottom of region58 output value
15:8	R/W	0	data2 : //unsigned , default = 0 ,bottom of region57 output value
7:0	R/W	0	data3 : //unsigned , default = 0 ,bottom of region56 output value

**Table 9-1284 VPP\_DNLP\_CTRL\_15 0x1d90**

Bit(s)	R/W	Default	Description
31:24	R/W	0	data0 : //unsigned , default = 0 ,bottom of region63 output value
23:16	R/W	0	data1 : //unsigned , default = 0 ,bottom of region62 output value
15:8	R/W	0	data2 : //unsigned , default = 0 ,bottom of region61 output value
7:0	R/W	0	data3 : //unsigned , default = 0 ,bottom of region60 output value

**Table 9-1285 VPP\_SRSHARP0\_CTRL 0x1d91**

Bit(s)	R/W	Default	Description
28:16	R/W	0	srsharp_demo_split_sz : //unsigned , default = 0 ,srsharp demo top/bot left/right width
5:4	R/W	0	srsharp_demo_disp_post : //unsigned , default = 0 ,srsharp demo display position
3	R/W	0	srsharp_demo_en : //unsigned , default = 0 ,srsharp demo enable
2	R/W	0	srsharp_c444to422_en : //unsigned , default = 0 ,srsharp format444 convert 422 enable
1	R/W	0	srsharp_buf_en : //unsigned , default = 0 ,srsharp buffer enable
0	R/W	0	srsharp_en : //unsigned , default = 0 ,srsharp enable

**Table 9-1286 VPP\_DOLBY\_CTRL 0x1d93**

Bit(s)	R/W	Default	Description
17	R/W	0	pps_dummy_data_mode : //unsigned , default = 0 ,pps_dummy_data_mode 1:vd1_scale need setting 8 bits 0:vd1_scale need setting 10 bits
16	R/W	0	dolby3_path_sel : //unsigned , default = 0 ,1:dolby2->osd_mat->post_blend->dolby3->wm 0:dolby2->dolby3->osd_mat->post_blend->wm
10	R/W	0	vpp_clip_ext_mode2 : //unsigned , default = 0 ,Vpp out clip mode 1:10bit 0:12bit
9	R/W	0	vpp_clip_ext_mode1 : //unsigned , default = 0 ,Vpp Vd2 input clip mode 1:10bit 0:12bit
8	R/W	0	vpp_clip_ext_mode0 : //unsigned , default = 0 ,Vpp Vd1 input clip mode 1:10bit 0:12bit
3	R/W	0	vpp_dolby3_en : //unsigned , default = 0 ,dolby_core3 enable,active high

Bit(s)	R/W	Default	Description
2	R/W	0	vpp_dpath_sel2 : //unsigned , default = 0 ,data by_pass from dolby_core3 output to gainoff output.
1	R/W	0	/
0	R/W	0	vpp_dpath_sel0 : //unsigned , default = 0 ,by_pass from preblend to module vadj1 input

Table 9-1287 VPP\_SYNC\_SEL0 0x1d96

Bit(s)	R/W	Default	Description
31:0	R/W	0	sync_sel_bits : //unsigned ,default = 0,sync_sel bits for VPP_DOLBY_CTRL

Table 9-1288 VPP\_CCORING\_CTRL 0x1da0

Bit(s)	R/W	Default	Description
27:16	R/W	0	reg_bypass_ccoring_ythd : // unsigned , default = 0 , bypass_ccoring_ythd
15:8	R/W	0	ccoring_th : // unsigned , default = 0 , Chroma coring threshold
3:0	R/W	0	ccoring_slope : // unsigned , default = 0 , Chroma coring slope

Table 9-1289 VPP\_VE\_ENABLE\_CTRL 0x1da1

Bit(s)	R/W	Default	Description
29:28	R/W	0	dnlp_gclk_ctrl : // unsigned , default = 0 ,dnlp gclk ctrl
27:26	R/W	0	blackext_gclk_ctrl : // unsigned , default = 0 ,blackext gclk ctrl
25:24	R/W	0	ccoring_gclk_ctrl : // unsigned , default = 0 ,chroma coring gclk ctrl
20	R/W	0	demo_ccoring_enable : // unsigned , default = 0 ,demo chroma coring enable
19	R/W	0	demo_blackext_enable : // unsigned , default = 0 ,demo black extension enable
18	R/W	0	demo_dnlp_enable : // unsigned , default = 0 ,demo dynamic nonlinear luma processing enable
15:14	R/W	0	demo_disp_position : // unsigned , default = 0 ,2'b00: demo adjust on top, 2'b01: demo adjust on bottom, 2'b10: demo adjust on left, 2'b11: demo adjust on right
4	R/W	0	ccoring_en : // unsigned , default = 0 , chroma coring enable
3	R/W	0	blackext_en : // unsigned , default = 0 , black extension enable
2	R/W	0	dnlp_en : // unsigned , default = 0 , dynamic nonlinear luma processing enable

Table 9-1290 VPP\_VE\_DEMO\_LEFT\_TOP\_SCREEN\_WIDTH 0x1da2

Bit(s)	R/W	Default	Description
12:0	R/W	0	ve_demo_left_top_screen_width : // unsigned , default = 0 demo left or top screen width

**Table 9-1291 VPP\_VE\_DEMO\_CENTER\_BAR 0x1da3**

Bit(s)	R/W	Default	Description
31	R/W	0	ve_demo_center_bar : // unsigned , default = 0 center bar enable
27:24	R/W	0	ve_demo_center_bar : // unsigned , default = 0 center bar width (*2)
23:16	R/W	0	ve_demo_center_bar : // unsigned , default = 0 center bar Cr (*4)
15:8	R/W	0	ve_demo_center_bar : // unsigned , default = 0 center bar Cb (*4)
7:0	R/W	0	ve_demo_center_bar : // unsigned , default = 0 center bar y (*4)

**Table 9-1292 VPP\_VE\_H\_V\_SIZE 0x1da4**

Bit(s)	R/W	Default	Description
28:16	R/W	780	ve_line_length : // unsigned , default = 780 ve_line_length
12:0	R/W	438	ve_pic_height : // unsigned , default = 438 ve_pic_height

**Table 9-1293 VPP\_OUT\_H\_V\_SIZE 0x1da5**

Bit(s)	R/W	Default	Description
28:16	R/W	780	vppout_line_length : / unsigned , default = 780 vd1_scale_out hsize
12:0	R/W	438	vppout_pic_height : // unsigned , default = 438 vd1_scale_out vsize

**Table 9-1294 VPP\_VDO\_MEAS\_CTRL 0x1da8**

Bit(s)	R/W	Default	Description
10:0	R/W	0	vdo_meas_ctrl : // unsigned , default = 0 vdo_meas_ctrl

**Table 9-1295 VPP\_VDO\_MEAS\_VS\_COUNT\_HI 0x1da9**

Bit(s)	R/W	Default	Description
19 :16	RO	0	ro_ind_meas_count_n // unsigned , default = 0 ind_meas_count_n, every number of sync_span vsyncs, this counter add 1
15 :0,	RO	0	ro_counter_h // unsigned , default = 0 high bit portion of counter

**Table 9-1296 VPP\_VDO\_MEAS\_VS\_COUNT\_LO 0x1daa**

Bit(s)	R/W	Default	Description
31 :0	RO	0	ro_counter_l // unsigned , default = 0, low bit portion of counter

**Table 9-1297 VPP\_INPUT\_CTRL 0x1dab**

Bit(s)	R/W	Default	Description
11:9	R/W	0	vd2_sel : // unsigned , default = 0, 001: select vd1_din, 010: select vd2_din, 011: select d2d3_l_din, 100: d2d3_r_din, otherwise no selection
8:6	R/W	0	vd1_l_sel : // unsigned , default = 0, 001: select vd1_din, 010: select vd2_din, 011: select d2d3_l_din, 100: d2d3_r_din, otherwise no selection, vd1_l_sel selected cannot be used as the source of vd1_r_sel or vd2_sel
5:3	R/W	0	vd1_r_sel : // unsigned , default = 0, 001: select vd1_din, 010: select vd2_din, 011: select d2d3_l_din, 100: d2d3_r_din, otherwise no selection, useful only vd1_interleave_mode is not 00. And the source vd1_r_sel used can not used for the vd2_sel any more bit 2:0 vd1_interleave_mode // unsigned , default = 0, 000: no interleave, 001: pixel interleaving, 010: line interleaving, 011: 2 pixel interleaving, 100: 2 line interleaving

**Table 9-1298 VPP\_CTI\_CTRL2 0x1dac**

Bit(s)	R/W	Default	Description
25:24	R/W	0	cti_bpf_sel : // unsigned , default = 0
20:16	R/W	0	cti_blend_factor_gama : // unsigned , default = 0
12:8	R/W	0	cti_blend_factor_beta : // unsigned , default = 0
4:0	R/W	0	cti_blend_factor_alpha : // unsigned , default = 0

**Table 9-1299 VPP\_WRBAK\_CTRL\_SEC 0x1dad**

Bit(s)	R/W	Default	Description
31	R/W	0	vpp_wrbak_sel // unsigned , default = 0, 1: VPP_WRBAK_CTRL regs set to vpp_wrbak_data_ini, Cbus can't access 0: VPP_WRBAK_CTRL reg can be written bit
30:0	R/W	0	vpp_wrbak_data_ini // unsigned , default = 0,

**Table 9-1300 VD1\_BLEND\_SRC\_CTRL\_SEC 0x1dae**

Bit(s)	R/W	Default	Description
31	R/W	0	vd1_blend_src_sel : // unsigned , default = 0, 1: VD1_BLEND_SRC_CTRL regs set to vd1_blend_src_data_ini, Cbus can't access 0: VD1_BLEND_SRC_CTRL reg can be written
30:0	R/W	0	vd1_blend_src_data_ini : // unsigned , default = 0,

**Table 9-1301 VD2\_BLEND\_SRC\_CTRL\_SEC 0x1daf**

Bit(s)	R/W	Default	Description
31	R/W	0	vd2_blend_src_sel : // unsigned , default = 0, 1: VD2_BLEND_SRC_CTRL regs set to vd1_blend_src_data_ini, Cbus can't access 0: VD2_BLEND_SRC_CTRL reg can be written
30:0	R/W	0	vd2_blend_src_data_ini : // unsigned , default = 0,

**Table 9-1302 OSD1\_BLEND\_SRC\_CTRL\_SEC 0x1db0**

Bit(s)	R/W	Default	Description
31	R/W	0	osd1_blend_src_sel : // unsigned , default = 0, 1: OSD1_BLEND_SRC_CTRL regs set to osd1_blend_src_data_ini,Cbus can't access 0: OSD1_BLEND_SRC_CTRL reg can be written
30:0	R/W	0	osd1_blend_src_data_ini : // unsigned , default = 0,

**Table 9-1303 OSD2\_BLEND\_SRC\_CTRL\_SEC 0x1db1**

Bit(s)	R/W	Default	Description
31	R/W	0	osd2_blend_src_sel : // unsigned , default = 0, 1: OSD2_BLEND_SRC_CTRL regs set to osd2_blend_src_data_ini,Cbus can't access 0: OSD2_BLEND_SRC_CTRL reg can be written
30:0	R/W	0	osd2_blend_src_data_ini : // unsigned , default = 0,

**Table 9-1304 VPP\_INT\_LINE\_NUM 0x1dce**

Bit(s)	R/W	Default	Description
12:0	R/W	0x0	interrupt_line_num : //unsigned, default== 0x1fff,line number use to generate interrupt when line == this number

**Table 9-1305 VPP\_OFIFO\_URG\_CTRL 0x1dd8**

Bit(s)	R/W	Default	Description
31	R/W	0x0	urgent_hold : //unsigned, default== 0, urgent fifo hold enable
28:12	R/W	0x0	urgent_fifo_th : //unsigned, default== 0, urgent fifo hold line threshold
15	R/W	0x0	urgent_ctrl_en : //unsigned, default== 0, urgent_ctrl_en
14	R/W	0x0	urgent_wr : //unsigned, default== 0, urgent_wr, if true for write buffer
13	R/W	0x0	out_inv_en : //unsigned, default== 0, out_inv_en
12	R/W	0x0	urgent_ini_value : //unsigned, default == 0, urgent_ini_value
11:6	R/W	0x0	up_th : //unsigned, default == 0, up_th up threshold
5:0	R/W	0x0	dn_th : //unsigned, default == 0, dn_th dn threshold

**Table 9-1306 VPP\_CLIP\_MISC0 0x1dd9**

Bit(s)	R/W	Default	Description
29:20	R/W	1023	r : // unsigned, default == 1023, final clip r channel top
19:10	R/W	1023	g : // unsigned, default == 1023, final clip g channel top
9: 0	R/W	1023	b : // unsigned, default == 1023, final clip b channel top



**Table 9-1307 VPP\_CLIP\_MISC1 0x1dda**

Bit(s)	R/W	Default	Description
29:20	R/W	0x0	r : // unsigned, default == 0, final clip r channel bottom
19:10	R/W	0x0	g : // unsigned, default == 0, final clip g channel bottom
9: 0	R/W	0x0	b : // unsigned, default == 0, final clip b channel bottom

**Table 9-1308 VPP\_VD1\_CLIP\_MISC0 0x1de1**

Bit(s)	R/W	Default	Description
29:20	R/W	1023	r : //unsigned, default == 1023, vd1 clip r channel top
19:10	R/W	1023	g : //unsigned, default == 1023, vd1 clip g channel top
9: 0	R/W	1023	b : //unsigned, default == 1023, vd1 clip b channel top

**Table 9-1309 VPP\_VD1\_CLIP\_MISC1 0x1de2**

Bit(s)	R/W	Default	Description
29:20	R/W	0x0	r : //unsigned, default = 0, vd1 clip r channel bottom
19:10	R/W	0x0	g : //unsigned, default = 0, vd1 clip g channel bottom
9: 0	R/W	0x0	b : //unsigned, default = 0, vd1 clip b channel bottom

**Table 9-1310 VPP\_VD2\_CLIP\_MISC0 0x1de3**

Bit(s)	R/W	Default	Description
29:20	R/W	1023	r : //unsigned, default = 1023, vd2 clip r channel top
19:10	R/W	1023	g : //unsigned, default = 1023, vd2 clip g channel top
9: 0	R/W	1023	b : //unsigned, default = 1023, vd2 clip b channel top

**Table 9-1311 VPP\_VD2\_CLIP\_MISC1 0x1de4**

Bit(s)	R/W	Default	Description
29:20	R/W	0x0	r : // unsigned, default = 0, vd2 clip r channel bottom
19:10	R/W	0x0	g : // unsigned, default = 0, vd2 clip g channel bottom
9: 0	R/W	0x0	b : // unsigned, default = 0, vd2 clip b channel bottom

**Table 9-1312 VPP\_VD2\_HDR\_IN\_SIZE 0x1df0**

Bit(s)	R/W	Default	Description
18:16	R/W	0	vd2_in_v_size : // unsigned, default = 0x2d0, VPP VD2 input vsize
12:0	R/W	0	vd2_in_h_size : // unsigned, default = 0x1e0, VPP VD2 input hsize

**Table 9-1313 VPP\_OSD1\_IN\_SIZE 0x1df1**

Bit(s)	R/W	Default	Description
18:16	R/W	0	osd1_in_v_size : // unsigned, default = 0x2d0, VPP osd1 input vsize
12:0	R/W	0	osd1_in_h_size : // unsigned, default = 0x1e0, VPP osd1 input hsize

**Table 9-1314 VPP\_GCLK\_CTRL2 0x1df2**

Bit(s)	R/W	Default	Description
13:13	R/W	0	vks_gclk_ctrl : // unsigned, default = 0 ,vks gating clock

**Table 9-1315 VD2\_PPS\_DUMMY\_DATA 0x1df4**

Bit(s)	R/W	Default	Description
23:16	R/W	0x0	Y : //unsigned, default = 0, vd2 scale dummy data
15:8	R/W	0x0	CB : //unsigned, default = 0, vd2 scale dummy data
7: 0	R/W	0x0	CR : //unsigned, default = 0, vd2 scale dummy data

**Table 9-1316 VPP\_OSD1\_BLD\_H\_SCOPE 0x1df5**

Bit(s)	R/W	Default	Description
28:16	R/W	0	blend_osd1_h_start : //unsigned, default = 0x0
12:0	R/W	0	blend_osd1_h_end : //unsigned, default = 0x2d0

**Table 9-1317 VPP\_OSD1\_BLD\_V\_SCOPE 0x1df6**

Bit(s)	R/W	Default	Description
28:16	R/W	0	blend_osd1_v_start : //unsigned, default = 0x0
12:0	R/W	0	blend_osd1_v_end : //unsigned, default = 0x1e0

**Table 9-1318 VPP\_OSD2\_BLD\_H\_SCOPE 0x1df7**

Bit(s)	R/W	Default	Description
28:16	R/W	0x0	blend_osd2_h_start : //unsigned, default = 0
12:0	R/W	0x0	blend_osd2_h_end : //unsigned, default = 0x2d0

**Table 9-1319 VPP\_OSD2\_BLD\_V\_SCOPE 0x1df8**

Bit(s)	R/W	Default	Description
28:16	R/W	0x0	blend_osd2_v_start : //unsigned, default = 0
12:0	R/W	0x0	blend_osd2_v_end : //unsigned, default = 0x1e0

**Table 9-1320 VPP\_WRBK\_CTRL 0x1df9**

Bit(s)	R/W	Default	Description
23:16	R/W	0	wrbak_din_Inblank : //unsigned, default = 0,
11:8	R/W	0	wrbak_din_only_en : //unsigned, default = 0,
6:4	R/W	0	wrbak_chan1_sel : //unsigned, default = 0,1:vd1 2:vd2 3:osd1 4:osd2 5:posd_blend
2:0	R/W	0	wrbak_chan0_sel : //unsigned, default = 0,1:vd1 2:vd2 3:osd1 4:osd2 5:posd_blend

**Table 9-1321 VPP\_SLEEP\_CTRL 0x1dfa**

Bit(s)	R/W	Default	Description
31	R/W	1	sleep_always_en : //unsigned, default = 1
30	R/W	0	sleep_always_dis : //unsigned, default = 0
29:16	R/W	0	sleep_line_len : //unsigned, default = 0
15:14	R/W	0	sleep_mode : //unsigned, default = 0
13:0	R/W	0	sleep_beg_line : //unsigned, default = 0

**Table 9-1322 VD1\_BLEND\_SRC\_CTRL 0x1dfb**

Bit(s)	R/W	Default	Description
16	R/W	0	vd1_postbld_premult : //unsigned, default = 0
11:8	R/W	1	vd1_postbld_src : //unsigned, default = 1 , 0:close 1:vd1 2:vd2 3:osd1 4:osd2
4	R/W	0	vd1_prebld_premult : //unsigned, default = 0
3:0	R/W	1	vd1_prebld_src : //unsigned, default = 1 , 0:close 1:vd1 2:vd2 3:osd1 4:osd2

**Table 9-1323 VD2\_BLEND\_SRC\_CTRL 0x1dfc**

Bit(s)	R/W	Default	Description
20	R/W	0	vd2_blend_path_sel : //unsigned, default = 0
16	R/W	0	vd2_postbld_premult : //unsigned, default = 0
11:8	R/W	2	vd2_postbld_src : //unsigned, default = 2 , 0:close 1:vd1 2:vd2 3:osd1 4:osd2
4	R/W	0	vd2_prebld_premult : //unsigned, default = 0
3:0	R/W	0	vd2_prebld_src : //unsigned, default = 0 , 0:close 1:vd1 2:vd2 3:osd1 4:osd2

**Table 9-1324 OSD1\_BLEND\_SRC\_CTRL 0x1dfd**

Bit(s)	R/W	Default	Description
20	R/W	0	osd1_blend_path_sel : //unsigned, default = 0
16	R/W	0	osd1_postbld_premult : //unsigned, default = 0
11:8	R/W	3	osd1_postbld_src : //unsigned, default = 3 , 0:close 1:vd1 2:vd2 3:osd1 4:osd2

Bit(s)	R/W	Default	Description
4	R/W	0	osd1_prebld_premult : //unsigned, default = 0
3:0	R/W	0	osd1_prebld_src : //unsigned, default = 0 ,0:close 1:vd1 2:vd2 3:osd1 4:osd2

Table 9-1325 OSD2\_BLEND\_SRC\_CTRL 0x1dfe

Bit(s)	R/W	Default	Description
20	R/W	0	osd2_blend_path_sel : //unsigned, default = 0
16	R/W	0	osd2_postbld_premult : //unsigned, default = 0
11:8	R/W	4	osd2_postbld_src : //unsigned, default = 4 , 0:close 1:vd1 2:vd2 3:osd1 4:osd2
4	R/W	0	osd2_prebld_premult : //unsigned, default = 0
3:0	R/W	0	osd2_prebld_src : //unsigned, default = 0 , 0:close 1:vd1 2:vd2 3:osd1 4:osd2

### 9.2.3.23 CM Registers

Table 9-1326 VPP\_CHROMA\_ADDR\_PORT 0x1d70

Bit(s)	R/W	Default	Description
31-0	R/W	0	Color management address port

Table 9-1327 VPP\_CHROMA\_DATA\_PORT 0x1d71

Bit(s)	R/W	Default	Description
31-0	R/W	0	Color management data port

Color management internal registers is indirectly accessed by the registers VPP\_CHROMA\_ADDR\_PORT and VPP\_CHROMA\_DATA\_PORT.

Color management registers

The example to access the Color management registers is like this:

Wr(VPP\_CHROMA\_ADDR\_PORT);

Wr(VPP\_CHROMA\_DATA\_PORT);

Table 9-1328 REG\_CHROMA\_CONTROL 0x30

Bit(s)	R/W	Default	Description
31	R/W	0	reg_chroma_en. enable color manage function 1'b1: enable 1'b0: bypass
6	R/W	0	sat_sel. uv_max or $u^2+v^2$ selected as sat for reference 1'b1: uv_max(default) 1'b0: $u^2+v^2$
5	R/W	0	uv_adj_en. final uv_adjust enable 1'b1: enable 1'b0: bypass

Bit(s)	R/W	Default	Description
2	R/W	0	hue_en. rgb to hue enable 1'b1: enable(default) 1'b0: bypass
1-0	R/W	0	csc_sel. define input YUV with different color type 2'b00: 601(16-235) 2'b01: 709(16-235) 2'b10: 601(0-255) 2'b11: 709(0-255)

Table 9-1329 SAT\_BYB\_NODE0 0x200

Bit(s)	R/W	Default	Description
31-24	R/W	0	The 4th node, the same as below
23-16	R/W	0	The 3th node, the same as below
15-8	R/W	0	The 2th node, the same as below
7-0	R/W	0	Signed, The 1th node about saturation gain offset along Y coordinate, the gain normalized to 128 as "1".

Table 9-1330 SAT\_BYB\_NODE1 0x201

Bit(s)	R/W	Default	Description
31-24	R/W	0	The 8th node, the same as below
23-16	R/W	0	The 7th node, the same as below
15-8	R/W	0	The 6th node, the same as below
7-0	R/W	0	Signed, The 5th node about saturation gain offset along Y coordinate, the gain normalized to 128 as "1".

Table 9-1331 SAT\_BYB\_NODE2 0x202

Bit(s)	R/W	Default	Description
31-8	R/W	0	reserved
7-0	R/W	0	Signed, The 9th node about saturation gain offset along Y coordinate, the gain normalized to 128 as "1".

Table 9-1332 SAT\_SRC\_NODE 0x203

Bit(s)	R/W	Default	Description
31-28	R/W	0	reserved
27-16	R/W	0x800	unsign, Threshold of input saturation for second & third piece. i.e. it is boundary for reg_CM2_Adj_Sat_via_HS[1][:]and reg_CM2_Adj_Sat_via_HS[2][:]
15-12	R/W	0	reserved
11-0	R/W	0x400	unsign, Threshold of input saturation for first and second piece.i.e. it is boundary for reg_CM2_Adj_Sat_via_HS[0][:] and reg_CM2_Adj_Sat_via_HS[1][:]

Table 9-1333 CM\_ENH\_SFT\_MODE 0x204

Bit(s)	R/W	Default	Description
31-11	R/W	0	reserved
10-8	R/W	0	Hue offset adjustments scale for Reg_CM2_Adj_Hue_via_H[:]& Reg_CM2_Adj_Hue_via_S[:]& Reg_CM2_Adj_Hue_via_Y[:]: 0: no scale up; 1: upscale by 2 - (-128,127)x2; 2: upscale by 4 - (-128,127)x4; 3: upscale by 8 - (-128,127)x8;
7-6	R/W	0	reserved
5-4	R/W	0	Luma offset adjustments scale for reg_CM2_Adj_Luma_via_Hue[i]: 0: no scale up; 1: upscale by2 - (-128,127)x2; 2: upscale by 4 - (-128,127)x4; 3: upscale by 8 - (-128,127)x8;
3-2	R/W	0	Saturation again adjustments scale for reg_CM2_Adj_Sat_via_Y[::] &Reg_CM2_Adj_SatGLBgain_via_Y[:]: 0: no scale up/down; 1: dnscale by 2 (-128,127)/2; 2: dnscale by 4 (-128,127)/4; 3: dnscale by 8 (-128,127)/8;
1-0	R/W	0	Saturation again adjustments scale for reg_CM2_Adj_Sat_via_HS[:]: 0: no scale up/down; 1: dnscale by 2 (-128,127)/2; 2: dnscale by 4 (-128,127)/4; 3: dnscale by 8 (-128,127)/8;

Table 9-1334 FRM\_SIZE 0x205

Bit(s)	R/W	Default	Description
31-29	R/W	0	reserved
28-16	R/W	0x438	The frame height size
15-13	R/W	0	reserved
12-0	R/W	0x780	The frame width size

Table 9-1335 FITLER\_CFG 0x206

Bit(s)	R/W	Default	Description
31-5	R/W	0	reserved
4	R/W	0	Horizontal Interleave filter (zero-padding) for 3D considerations: 0: using non-zero padding LPF 1: using zero-padding LPF
3-0	R/W	0	Apply CM on LP portion or original video pixels options: bits[1:0]: is for Luma path control; bits[3:2]: is for U/V path control; 0: no filter but still match the delay; 1: 5 taps LP filter 2: 9 taps LP filter 3: 13 taps LP filter

**Table 9-1336 CM\_GLOBAL\_GAIN 0x207**

Bit(s)	R/W	Default	Description
31-28	R/W	0	reserved
27-16	R/W	0x200	Global Saturation Gain for general color adjustments (0~4095 $\Leftrightarrow$ 0~8), 512 normalized to "1".
15-12	R/W	0	reserved
11-0	R/W	0	Global Hue offsets for general color adjustments (0~4095 $\Leftrightarrow$ 0~360 degree)

**Table 9-1337 CM\_ENH\_CTL 0x208**

Bit(s)	R/W	Default	Description
31-6	R/W	0	reserved
5	R/W	0	CM Bypass 1: Bypass 0: not bypass
4	R/W	0	Enable signal for CM2 Hue adjustments;
3	R/W	0	Enable signal for CM2 Saturation adjustments;
2	R/W	0	Enable signal for CM2 Luma adjustments;
1	R/W	0	cm2_filt_en :apply cm on lp portion enable
0	R/W	0	CM1 enable signal

**Table 9-1338 ROI\_X\_SCOPE 0x209**

Bit(s)	R/W	Default	Description
31-28	R/W	0	reserved
27-16	R/W	0	Ending col index of the Region of Interest (ROI)
15-12	R/W	0	reserved
11-0	R/W	0	Start col index of the Region of Interest (ROI)

**Table 9-1339 ROI\_Y\_SCOPE 0x20a**

Bit(s)	R/W	Default	Description
31-28	R/W	0	reserved
27-16	R/W	0	Ending col index of the Region of Interest (ROI)
15-12	R/W	0	reserved
11-0	R/W	0	Start col index of the Region of Interest (ROI)

**Table 9-1340 POI\_XY\_DIR 0x20b**

Bit(s)	R/W	Default	Description
31-28	R/W	0	reserved
27-16	R/W	0	Row index of the pixel(position) of Interest (POI)

Bit(s)	R/W	Default	Description
15-12	R/W	0	reserved
11-0	R/W	0	Col index of the pixel(position) of Interest (POI)

**Table 9-1341 COI\_Y\_SCOPE 0x20c**

Bit(s)	R/W	Default	Description
31-28	R/W	0	reserved
27-16	R/W	0	Higher bound of luma value for color of interest (COI), 8bits precision
15-12	R/W	0	reserved
11-0	R/W	0	Lower bound of luma value for color of interest (COI), 8bits precision

**Table 9-1342 COI\_H\_SCOPE 0x20d**

Bit(s)	R/W	Default	Description
31-28	R/W	0	reserved
27-16	R/W	0	Higher bound of Hue value for color of interest (COI), 12 8bits precision
15-12	R/W	0	reserved
11-0	R/W	0	Lower bound of Hue value for color of interest (COI), 12 bits precision

**Table 9-1343 COI\_S\_SCOPE 0x20e**

Bit(s)	R/W	Default	Description
31-28	R/W	0	reserved
27-16	R/W	0	Higher bound of Sat value for color of interest (COI), 12 8bits precision
15-12	R/W	0	reserved
11-0	R/W	0	Lower bound of Sat value for color of interest (COI), 12 bits precision



Table 9-1344 IFO\_MODE 0x20f

Bit(s)	R/W	Default	Description
31-8	R/W	0	reserved
7-4	R/W	0	Mode control for COI replacement, bit[3:2] control COI pixels: 0: no replacement for COI pixels 1: disable CM2 enhance for COI pixels; 2: keep COI pixels Y but replace HS by [*HS]; 3: replace COI pixels to [*YHS] bit[1:0] controls non-COI pixels: 0: no replacement for non-COI pixels 1: disable CM2 enhance for non-COI pixels; 2: keep COI pixels Y but replace HS by [*HS]; 3: replace non- COI pixels to [*YHS]
3-0	R/W	0	Enhance mode control of pixels inside and outside Region of Interest (ROI) , bit [3:2] control ROI: 0: enable CM2 processing in ROI; 1: disable CM2 processing in ROI; 2: keep ROI pixels Y but replace HS by [*HS]; 3: ow ROI pixels to [*YHS] bit [1:0] control pixels other than ROI similarly. 0: enable CM2 processing in non-ROI; 1: disable CM2 processing in non-ROI; 2: keep ROI pixels Y but replace HS by [*HS]; 3: ow non-ROI pixels to [*YHS]

Table 9-1345 POI\_RPL\_MODE 0x210

Bit(s)	R/W	Default	Description
31-4	R/W	0	reserved
27-16	R/W	0	Reg_cm2_after_v_offset
15-4	R/W	0	Reg_cm2_after_u_offset
3-0	R/W	0	Pixel of interest (POI) replacement mode: 0: no replacements; 1: one pixel of POI position replaced to [*YHS] 2: 3X3 pixels centering POI position replaced to [*YHS] 3: 5X5 pixels centering POI position replaced to [*YHS] ... 15: 29X29 pixels centering POI position replaced to [*YHS]

Table 9-1346 DEMO\_OWR\_YHS 0x211

Bit(s)	R/W	Default	Description
31-24	R/W	0	Saturation value overwriting to ROI/POI/COI; 12bits precision, equal to saturation precision.
23-12	R/W	0	Hue value overwriting to ROI/POI/COI; 12 bits precision, equal to 1/4 hue precision. E.g. { Reg_CM2Demo_OWR_H, 2'h0}
11-0	R/W	0	Luma value overwriting to ROI/POI/COI; 8bits precision, equal to 1/4 luma precision, e.g. { Reg_CM2Demo_OWR_Y, 2'h0}

**Table 9-1347 DEMO\_POI\_Y 0x212**

Bit(s)	R/W	Default	Description
31-8	RO	0	Reserved
7-0	RO	0	Luma value for pixel of interest (POI), only get locked higher 8bits

**Table 9-1348 DEMO\_POI\_H 0x213**

Bit(s)	R/W	Default	Description
31-12	RO	0	Reserved
11-0	RO	0	Hue value for pixel of interest (POI), only get locked higher 12bits

**Table 9-1349 DEMO\_POI\_S 0x214**

Bit(s)	R/W	Default	Description
31-12	RO	0	Reserved
11-0	RO	0	Saturation value for pixel of interest (POI), only get locked higher 12bits

**Table 9-1350 LUMA\_ADJ\_LIMT 0x215**

Bit(s)	R/W	Default	Description
31-28	R/W	0	reserved
27-16	R/W	0	Slope to do the Luma adjust degrade speed based on Saturation. It was normalized to 16 as '1'.
15-12	R/W	0	reserved
11-0	R/W	0	Threshold to saturation to do Luma adjustment degrade. Only pixels' saturation lower than this threshold will degrade the Luma adjustment.

**Table 9-1351 SAT\_ADJ\_LIMT 0x216**

Bit(s)	R/W	Default	Description
31-28	R/W	0	reserved
27-16	R/W	0	Slope to do the Sat adjust degrade speed based on Saturation. It was normalized to 16 as '1'.
15-12	R/W	0	reserved
11-0	R/W	0	Threshold to saturation to do Sat adjustment degrade. Only pixels' saturation lower than this threshold will degrade the Luma adjustment.

**Table 9-1352 HUE\_ADJ\_LIMT 0x217**

Bit(s)	R/W	Default	Description
31-28	R/W	0	reserved
27-16	R/W	0	Slope to do the Hue adjust degrade speed based on Saturation. It was normalized to 16 as '1'.

Bit(s)	R/W	Default	Description
15-12	R/W	0	reserved
11-0	R/W	0	Threshold to saturation to do Hue adjustment degrade. Only pixels' saturation lower than this threshold will degrade the Luma adjustment.

Table 9-1353 UVHS\_OFST 0x218

Bit(s)	R/W	Default	Description
31-24	R/W	0	V offset after CM2, under s10 scale
23-16	R/W	0	U offset after CM2, under s10 scale
15-8	R/W	0	V offset before CM2, under s10 scale
7-0	R/W	0	U offset before CM2, under s10 scale.

Table 9-1354 HUE\_CFG\_PARA 0x219

Bit(s)	R/W	Default	Description
31-17	R/W	0	reserved
16	R/W	0	Options to protect HUE after CM2 adjustments. This will be added to avoid HUE distortion if Saturation is enhanced too much.
15-13	R/W	0	Hue adjustment via HS the Saturation division mode: 0: 1024/2048/3072, 4095; 1: 512, 1024, 1536, 2048; 2: 256, 512, 768, 1024; 3: 128, 256, 384, 512; 4: 512/1024/2048/4096; 5: 256/512/1024/2048; 6: 128/256/512/1024; 7: 64, 128, 256, 512
12	R/W	0	Hue slice division mode: 0: 32 pieces, 360/32 degrees each slice; 1/up: first 20 slices with 360/64 degrees each slice, others 360/16 degrees each slices. Notes, this option provide options to get more precise Hue adjustments for FTC/ Red and so on
11-0	R/W	0	Hue offset before CM2 adjustment, this will provide options to divide the Hue slices with a precise offset. But need to compensate back with the global Hue after CM2 adjustments

Table 9-1355 DEMO\_SPLT\_CFG 0x21a

Bit(s)	R/W	Default	Description
31-22	R/W	0	reserved
21-20	R/W	0	Demo split post
19-16	R/W	0	Demo split width
12-0	R/W	0	Demo split mode

Table 9-1356 DEMO\_SPLT\_YHS 0x21b

Bit(s)	R/W	Default	Description
31-24	R/W	0	Luma value
23-12	R/W	0	Hue value
11-0	R/W	0	Sat value

Table 9-1357 XUYCC\_YSCP\_REG 0x21c

Bit(s)	R/W	Default	Description
27:16	R/W	0x3ff	xvycc_y_max
11:0	R/W	0x0	xvycc_y_min

Table 9-1358 XUYCC\_USCP\_REG 0x21d

Bit(s)	R/W	Default	Description
27:16	R/W	0x3ff	xvycc_u_max
11:0	R/W	0x0	xvycc_u_min

Table 9-1359 XUYCC\_VSCP\_REG 0x21e

Bit(s)	R/W	Default	Description
27:16	R/W	0x3ff	xvycc_v_max
11:0	R/W	0x0	xvycc_v_min

the main adjust parameter is saved according to 32 hue node order, one by one. The parameter of each hue node is same. All the parameter for each hue occupy 5 register-addr-space. For the addr-off-set aligned, we allocate 8 addr-space to each node parameter, for example,

the parameter of 1th node uses the address space : 0x100, 0x101, 0x102, 0x103, 0x104,

and 2th node uses the address space : 0x108, 0x109, 0x10a, 0x10b, 0x10c,

and 2th node uses the address space : 0x110, 0x111, 0x112, 0x113, 0x114,

.....

Table 9-1360 CM2\_ENH\_COEF0\_H00 0x100

Bit(s)	R/W	Default	Description
31-24	R/W	0	Same as last
23-16	R/W	0	Same as last
15-8	R/W	0	Signed, Saturation gain offset for three pieces saturation on Hue section (totally 32 sections) node 0; the gain normalized to 128 as "1".
7-0	R/W	0	Signed, Luma offsets for Hue section (totally 32 sections) nodes 0 , range (-128,127)

**Table 9-1361 CM2\_ENH\_COEF1\_H00 0x101**

Bit(s)	R/W	Default	Description
31-24	R/W	0	Signed, Hue offset for each four pieces Luma region on each Hue section (totally 32 sections) nodes, this is for $y=2/4$ , hue node 0
23-16	R/W	0	Signed, Hue offset for each four pieces Luma region on each Hue section (totally 32 sections) nodes, this is for $y=1/4$ , hue node 0
15-8	R/W	0	Signed, Hue offset for each four pieces Luma region on each Hue section (totally 32 sections) nodes, this is for $y=0$ , hue node 0
7-0	R/W	0	Signed, Hue offset on Hue section (totally 32 sections) node 0

**Table 9-1362 CM2\_ENH\_COEF2\_H00 0x102**

Bit(s)	R/W	Default	Description
31-24	R/W	0	Signed, Hue offset for each four pieces Saturation region on each Hue section (totally 32 sections) nodes; This is for $sat = 1/4$ , hue node 0
23-16	R/W	0	Signed, Hue offset for each four pieces Saturation region on each Hue section (totally 32 sections) nodes; This is for $sat = 0$ , hue node 0
15-8	R/W	0	Signed, Hue offset for each four pieces Luma region on each Hue section (totally 32 sections) nodes, this is for $y=4/4$ , hue node 0
7-0	R/W	0	Signed, Hue offset for each four pieces Luma region on each Hue section (totally 32 sections) nodes, this is for $y=3/4$ , hue node 0

**Table 9-1363 CM2\_ENH\_COEF3\_H00 0x103**

Bit(s)	R/W	Default	Description
31-24	R/W	0	Saturation gain offsetfor four pieces Luma on each Hue section (totally 32 sections) nodes; the gain normalized to 128 as "1". This is for $sat = 0$ , hue node 0
23-16	R/W	0	Signed, Hue offset for each four pieces Saturation region on each Hue section (totally 32 sections) nodes; This is for $sat = 4/4$ , hue node 0
15-8	R/W	0	Signed, Hue offset for each four pieces Saturation region on each Hue section (totally 32 sections) nodes; This is for $sat = 3/4$ , hue node 0
7-0	R/W	0	Signed, Hue offset for each four pieces Saturation region on each Hue section (totally 32 sections) nodes; This is for $sat = 2/4$ , hue node 0

**Table 9-1364 CM2\_ENH\_COEF4\_H00 0x104**

Bit(s)	R/W	Default	Description
31-24	R/W	0	Saturation gain offsetfor four pieces Luma on each Hue section (totally 32 sections) nodes; the gain normalized to 128 as "1". This is for $sat = 4/4$ , hue node 0
23-16	R/W	0	Saturation gain offsetfor four pieces Luma on each Hue section (totally 32 sections) nodes; the gain normalized to 128 as "1". This is for $sat = 3/4$ , hue node 0

Bit(s)	R/W	Default	Description
15-8	R/W	0	Saturation gain offset for four pieces Luma on each Hue section (totally 32 sections) nodes; the gain normalized to 128 as "1". This is for sat = 2/4, hue node 0
7-0	R/W	0	Saturation gain offset for four pieces Luma on each Hue section (totally 32 sections) nodes; the gain normalized to 128 as "1". This is for sat = 1/4, hue node 0

CM2\_ENH\_COEF0\_H01            0x108

CM2\_ENH\_COEF1\_H01            0x109

CM2\_ENH\_COEF2\_H01            0x10a

CM2\_ENH\_COEF3\_H01            0x10b

CM2\_ENH\_COEF4\_H01            0x10c

CM2\_ENH\_COEF0\_H02            0x110

CM2\_ENH\_COEF1\_H02            0x111

CM2\_ENH\_COEF2\_H02            0x112

CM2\_ENH\_COEF3\_H02            0x113

CM2\_ENH\_COEF4\_H02            0x114

.....

CM2\_ENH\_COEF0\_H31            0x1f8

CM2\_ENH\_COEF1\_H31            0x1f9

CM2\_ENH\_COEF2\_H31            0x1fa

CM2\_ENH\_COEF3\_H31            0x1fb

CM2\_ENH\_COEF4\_H31            0x1fc

### 9.2.3.24 VPP OSD1 SCALER Registers

**Table 9-1365 VPP\_OSD\_VSC\_PHASE\_STEP 0x1dc0**

Bit(s)	R/W	Default	Description
27-0	R/W	0x0100-0000	4.24 format

**Table 9-1366 VPP\_OSD\_VSC\_INI\_PHASE 0x1dc1**

Bit(s)	R/W	Default	Description
31-16	R/W	0x0	bottom vertical scaler initial phase
15-0	R/W	0x0	top vertical scaler initial phase

**Table 9-1367 VPP\_OSD\_VSC\_CTRL0 0x1dc2**

Bit(s)	R/W	Default	Description
25	R/W	0	Repeat last line en : 1:enable repeat last line 0:disable repeat last line
24	R/W	0x0	osd vertical Scaler enable
23	R/W	0x0	osd_prog_interlace 0: current field is progressive, 1: current field is interlace
22-21	R/W	0x0	osd_vsc_double_line_mode, bit1, double input width and half input height, bit0, change line buffer becomes 2 lines
20	R/W	0x0	osd_vsc_phase0_always_en
19	R/W	0x0	osd_vsc_nearest_en
17-16	R/W	0x0	osd_vsc_bot_rpt_l0_num
14-11	R/W	0x0	osd_vsc_bot_ini_rcv_num
9-8	R/W	0x0	osd_vsc_top_rpt_l0_num
6-3	R/W	0x0	osd_vsc_top_ini_rcv_num
2-0	R/W	0x0	osd_vsc_bank_length

**Table 9-1368 VPP\_OSD\_HSC\_PHASE\_STEP 0x1dc3**

Bit(s)	R/W	Default	Description
27-0	R/W	0x0100-0000	4.24 format

**Table 9-1369 VPP\_OSD\_HSC\_INI\_PHASE 0x1dc4**

Bit(s)	R/W	Default	Description
31-16	R/W	0x0	horizontal scaler initial phase1
15-0	R/W	0x0	horizontal scaler initial phase0

Table 9-1370 VPP\_OSD\_HSC\_CTRL0 0x1dc5

Bit(s)	R/W	Default	Description
22	R/W	0x0	osd horizontal Scaler enable
21	R/W	0x0	osd_hsc_double_pix_mode
20	R/W	0x0	osd_hsc_phase0_always_en
19	R/W	0x0	osd_vsc_nearest_en
17-16	R/W	0x0	osd_hsc_rpt_p0_num1
14-11	R/W	0x0	osd_hsc_ini_rcv_num1
9-8	R/W	0x0	osd_hsc_rpt_p0_num0
6-3	R/W	0x0	osd_hsc_ini_rcv_num0
2-0	R/W	0x0	osd_hsc_bank_length

Table 9-1371 VPP\_OSD\_HSC\_INI\_PAT\_CTRL 0x1dc6

Bit(s)	R/W	Default	Description
15-8	R/W	0x0	for 3D quincunx sub-sampling. pattern, each patten 1 bit, from lsb -> msb
6-4	R/W	0x0	pattern start
2-0	R/W	0x0	pattern end

Table 9-1372 VPP\_OSD\_SC\_DUMMY\_DATA 0x1dc7

Bit(s)	R/W	Default	Description
31-24	R/W	0x0	component 0 ,data = (dst_data >> 4) ,so 8 bit in 12bit mode, 6bit in 10bit mode
23-16	R/W	0x0	component 1 ,data = (dst_data >> 4) ,so 8 bit in 12bit mode, 6bit in 10bit mode
15-8	R/W	0x0	component 2 ,data = (dst_data >> 4) ,so 8 bit in 12bit mode, 6bit in 10bit mode
7-0	R/W	0x0	component 3 , alpha

Table 9-1373 VPP\_OSD\_SC\_CTRL0 0x1dc8

Bit(s)	R/W	Default	Description
27:16	R/W	0	osd_sc_gclk_ctrl : //unsigned,default = 0,osd_sc_gclk_ctrl
13	R/W	0	osd_sc_din_osd_alpha_mode : //unsigned,default = 0,osc_sc_din_osd2_alpha_mode, 1: (alpha >= 128) ? alpha -1: alpha, 0: (alpha >=1) ? alpha - 1: alpha.
12	R/W	0	osd_sc_dout_alpha_mode : //unsigned,default = 0,osc_sc_alpha_mode, 1: (alpha >= 128) ? alpha + 1: alpha, 0: (alpha >=1) ? alpha + 1: alpha.
11:4	R/W	0	osd_sc_alpha : //unsigned,default = 0,default alpha for vd1 or vd2 if they are selected as the source
3	R/W	0	osd_sc_path_en : //unsigned,default = 0,osd scaler path enable
2	R/W	0	osd_sc_en : //unsigned,default = 0,osd scaler enable



Table 9-1374 VPP\_OSD\_SCI\_WH\_M1 0x1dc9

Bit(s)	R/W	Default	Description
28-16	R/W	0x0	OSD scaler input width minus 1
12-0	R/W	0x0	OSD scaler input height minus 1

Table 9-1375 VPP\_OSD\_SCO\_H\_START\_END 0x1dca

Bit(s)	R/W	Default	Description
27-16	R/W	0x0	OSD scaler output horizontal start
11-0	R/W	0x0	OSD scaler output horizontal end

Table 9-1376 VPP\_OSD\_SCO\_V\_START\_END 0x1dcb

Bit(s)	R/W	Default	Description
27-16	R/W	0x0	OSD scaler output vertical start
11-0	R/W	0x0	OSD scaler output vertical end

Table 9-1377 VPP\_OSD\_SCALE\_COEF\_IDX 0x1dcc

Bit(s)	R/W	Default	Description
15	R/W	0x0	Because there are many coefficients used in the vertical filter and horizontal filters, //indirect access the coefficients of vertical filter and horizontal filter is used. //For vertical filter, there are 33x4 coefficients //For horizontal filter, there are 33x4 coefficients //Bit 15 index increment, if bit9 == 1 then (0: index increase 1, 1: index increase 2) else (index increase 2)
14	R/W	0x0	1: read coef through cbus enable, just for debug purpose in case when we wanna check the coef in ram in correct or not
9	R/W	0x0	if true, use 9bit resolution coef, other use 8bit resolution coef
8	R/W	0x0	type of index, 0: vertical coef, 1: horizontal coef
6-0	R/W	0x0	coef index

Table 9-1378 VPP\_OSD\_SCALE\_COEF 0x1dcd

Bit(s)	R/W	Default	Description
31-0	R/W	0x0	

Table 9-1379 OSD\_DB\_FLT\_CTRL 0x3140

Bit(s)	R/W	Default	Description
26	R/W	1	reg_nrdeband_reset1 : // unsigned , default = 0 0 : no reset seed 1: reload chroma seed
25	R/W	1	reg_nrdeband_reset0 : // unsigned , default = 0 0 : no reset seed 1: reload luma seed

Bit(s)	R/W	Default	Description
24	R/W	0	reg_nrdeband_rgb : // unsigned , default = 0 0 : yuv 1: RGB
23	R/W	0	reg_nrdeband_en11 : // unsigned , default = 1 debanding registers of side lines, [0] for luma, same for below
22	R/W	0	reg_nrdeband_en10 : // unsigned , default = 1 debanding registers of side lines, [1] for chroma, same for below
21	R/W	1	reg_nrdeband_siderand : // unsigned , default = 1 options to use side two lines use the rand, instead of use for the YUV three component of middle line, 0: seed [3]/bandrand[3] for middle line yuv; 1: seed[3]/bandrand[3] for nearby three lines Y;
20	R/W	0	reg_nrdeband_randmode : // unsigned , default = 0 mode of rand noise adding, 0: same noise strength for all difs; else: strenght of noise will not exceed the difs, MIN((pPKReg->reg_nrdeband_bandrand[m]), noise[m])
19:17	R/W	6	reg_nrdeband_bandrand2 : // unsigned , default = 6
15:13	R/W	6	reg_nrdeband_bandrand1 : // unsigned , default = 6
11: 9	R/W	6	reg_nrdeband_bandrand0 : // unsigned , default = 6
7	R/W	1	reg_nrdeband_hpxor1 : // unsigned , default = 1 debanding random hp portion xor, [0] for luma
6	R/W	1	reg_nrdeband_hpxor0 : // unsigned , default = 1 debanding random hp portion xor, [1] for chroma
5	R/W	0	reg_nrdeband_en1 : // unsigned , default = 1 debanding registers, for luma
4	R/W	0	reg_nrdeband_en0 : // unsigned , default = 1 debanding registers, for chroma
3: 2	R/W	2	reg_nrdeband_lpf_mode1 : // unsigned , default = 2 lpf mode, 0: 3x3, 1:3x5; 2: 5x5; 3:5x7
1: 0	R/W	2	reg_nrdeband_lpf_mode0 : // unsigned , default = 2 lpf mode, 0: 3x3, 1:3x5; 2: 5x5; 3:5x7

Table 9-1380 OSD\_DB\_FLT\_CTRL1 0x3141

Bit(s)	R/W	Default	Description
31:18			reserved
17:16	R/W	2	Reg_osddeband_noise_rs
15:12	R/W	8	Reg_osddeband_randgain
11			reserved
10:8	R/W	6	Reg_osddeband_bandrand5
7			reserved
6: 4	R/W	6	Reg_osddeband_bandrand4
3			reserved
2: 0	R/W	6	Reg_osddeband_bandrand3

**Table 9-1381 OSD\_DB\_FLT\_LUMA\_THRD 0x3142**

Bit(s)	R/W	Default	Description
31:30			
29:24	R/W	36	reg_nrdeband_luma_th3 : // unsigned , default = 7 elseif <th[1] use (lpf*3 + y)/4
23:22			
21:16	R/W	28	reg_nrdeband_luma_th2 : // unsigned , default = 5 elseif <th[1] use (lpf*3 + y)/4elseif elseif <th[3] (lpf*1 + 3*y)/4; else
15:14			
13: 8	R/W	24	reg_nrdeband_luma_th1 : // unsigned , default = 7 elseif <th[1] use (lpf*3 + y)/4
7: 6			
5: 0	R/W	20	reg_nrdeband_luma_th0 : // unsigned , default = 5 elseif <th[1] use (lpf*3 + y)/4elseif elseif

**Table 9-1382 OSD\_DB\_FLT\_LUMA\_THRD 0x3143**

Bit(s)	R/W	Default	Description
31:30			
29:24	R/W	36	reg_nrdeband_chrm_th3 : // unsigned , default = 7 elseif <th[1] use (lpf*3 + y)/4
23:22			
21:16	R/W	28	reg_nrdeband_chrm_th2 : // unsigned , default = 5 elseif <th[1] use (lpf*3 + y)/4elseif elseif <th[3] (lpf*1 + 3*y)/4; else
15:14			
13: 8	R/W	24	reg_nrdeband_chrm_th1 : // unsigned , default = 7 elseif <th[1] use (lpf*3 + y)/4
7: 6			
5: 0	R/W	20	reg_nrdeband_chrm_th0 : // unsigned , default = 5 elseif <th[1] use (lpf*3 + y)/4elseif elseif

**Table 9-1383 OSD\_DB\_FLT\_RANLUT 0x3144**

Bit(s)	R/W	Default	Description
23:21	R/W	1	reg_nrdeband_randslut7 : // unsigned , default = 1 lut0
20:18	R/W	1	reg_nrdeband_randslut6 : // unsigned , default = 1 lut0
17:15	R/W	1	reg_nrdeband_randslut5 : // unsigned , default = 1 lut0
14:12	R/W	1	reg_nrdeband_randslut4 : // unsigned , default = 1 lut0
11: 9	R/W	1	reg_nrdeband_randslut3 : // unsigned , default = 1 lut0
8: 6	R/W	1	reg_nrdeband_randslut2 : // unsigned , default = 1 lut0
5: 3	R/W	1	reg_nrdeband_randslut1 : // unsigned , default = 1 lut0
2: 0	R/W	1	reg_nrdeband_randslut0 : // unsigned , default = 1 lut0

**Table 9-1384 OSD\_DB\_FLT\_PXI\_THRD 0x3145**

Bit(s)	R/W	Default	Description
25:16	R/W	0	reg_nrdeband_yc_th1 : // unsigned , default = 0 to luma/ u/v  for using the denoise
9: 0	R/W	0	reg_nrdeband_yc_th0 : // unsigned , default = 0 to luma/ u/v  for using the denoise

**Table 9-1385 OSD\_DB\_FLT\_SEED\_Y 0x3146**

Bit(s)	R/W	Default	Description
31: 0	R/W	162143-8240	reg_nrdeband_seed0 : // unsigned , default = 1621438240 noise adding seed for Y. seed[0]= 0x60a52f20; as default

**Table 9-1386 OSD\_DB\_FLT\_SEED\_U 0x3147**

Bit(s)	R/W	Default	Description
31: 0	R/W	162143-8247	reg_nrdeband_seed1 : // unsigned , default = 1621438247 noise adding seed for U. seed[0]= 0x60a52f27; as default

**Table 9-1387 OSD\_DB\_FLT\_SEED\_V 0x3148**

Bit(s)	R/W	Default	Description
31: 0	R/W	162143-8242	reg_nrdeband_seed2 : // unsigned , default = 1621438242 noise adding seed for V. seed[0]= 0x60a52f22; as default

**Table 9-1388 OSD\_DB\_FLT\_SEED3 0x3149**

Bit(s)	R/W	Default	Description
31: 0	R/W	162143-8242	reg_nrdeband_seed3 : // unsigned , default = 1621438242 noise adding seed for V. seed[0]= 0x60a52f22; as default

**Table 9-1389 OSD\_DB\_FLT\_SEED4 0x314a**

Bit(s)	R/W	Default	Description
31: 0	R/W	162143-8242	reg_nrdeband_seed4 : // unsigned , default = 1621438242 noise adding seed for V. seed[0]= 0x60a52f22; as default

**Table 9-1390 OSD\_DB\_FLT\_SEED5 0x314b**

Bit(s)	R/W	Default	Description
31: 0	R/W	162143-8242	reg_nrdeband_seed5 : // unsigned , default = 1621438242 noise adding seed for V. seed[0]= 0x60a52f22; as default

### 9.2.3.25 VPP OSD2 SCALER Registers

**Table 9-1391 SCALER OSD2\_VSC\_PHASE\_STEP 0x3d00**

Bit(s)	R/W	Default	Description
27-0	R/W	0x0100-0000	4.24 format

**Table 9-1392 OSD2\_VSC\_INI\_PHASE 0x3d01**

Bit(s)	R/W	Default	Description
31-16	R/W	0x0	bottom vertical scaler initial phase
15-0	R/W	0x0	top vertical scaler initial phase

**Table 9-1393 OSD2\_VSC\_CTRL0 0x3d02**

Bit(s)	R/W	Default	Description
25	R/W	0	Repeat last line en : 1:enable repeat last line 0:disable repeat last line
24	R/W	0x0	osd vertical Scaler enable
23	R/W	0x0	osd_prog_interlace 0: current field is progressive, 1: current field is interlace
22-21	R/W	0x0	osd_vsc_double_line_mode, bit1, double input width and half input height, bit0, change line buffer becomes 2 lines
20	R/W	0x0	osd_vsc_phase0_always_en
19	R/W	0x0	osd_vsc_nearest_en
17-16	R/W	0x0	osd_vsc_bot_rpt_l0_num
14-11	R/W	0x0	osd_vsc_bot_ini_rcv_num
9-8	R/W	0x0	osd_vsc_top_rpt_l0_num
6-3	R/W	0x0	osd_vsc_top_ini_rcv_num
2-0	R/W	0x0	osd_vsc_bank_length

**Table 9-1394 OSD2\_HSC\_PHASE\_STEP 0x3d03**

Bit(s)	R/W	Default	Description
27-0	R/W	0x0100-0000	4.24 format

**Table 9-1395 OSD2\_HSC\_INI\_PHASE 0x3d04**

Bit(s)	R/W	Default	Description
31-16	R/W	0x0	horizontal scaler initial phase1
15-0	R/W	0x0	horizontal scaler initial phase0

Table 9-1396 OSD2\_HSC\_CTRL0 0x3d05

Bit(s)	R/W	Default	Description
22	R/W	0x0	osd horizontal Scaler enable
21	R/W	0x0	osd_hsc_double_pix_mode
20	R/W	0x0	osd_hsc_phase0_always_en
19	R/W	0x0	osd_vsc_nearest_en
17-16	R/W	0x0	osd_hsc_rpt_p0_num1
14-11	R/W	0x0	osd_hsc_ini_rcv_num1
9-8	R/W	0x0	osd_hsc_rpt_p0_num0
6-3	R/W	0x0	osd_hsc_ini_rcv_num0
2-0	R/W	0x0	osd_hsc_bank_length

Table 9-1397 OSD2\_HSC\_INI\_PAT\_CTRL 0x3d06

Bit(s)	R/W	Default	Description
15-8	R/W	0x0	for 3D quincunx sub-sampling. pattern, each patten 1 bit, from lsb -> msb
6-4	R/W	0x0	pattern start
2-0	R/W	0x0	pattern end

Table 9-1398 OSD2\_SC\_DUMMY\_DATA 0x3d07

Bit(s)	R/W	Default	Description
31-24	R/W	0x0	component 0 ,data = (dst_data >> 4) ,so 8 bit in 12bit mode, 6bit in 10bit mode
23-16	R/W	0x0	component 1 ,data = (dst_data >> 4) ,so 8 bit in 12bit mode, 6bit in 10bit mode
15-8	R/W	0x0	component 2 ,data = (dst_data >> 4) ,so 8 bit in 12bit mode, 6bit in 10bit mode
7-0	R/W	0x0	component 3 , alpha

Table 9-1399 OSD2\_SC\_CTRL0 0x3d08

Bit(s)	R/W	Default	Description
27:16	R/W	0	osd_sc_gclk_ctrl : //unsigned,default = 0,osd_sc_gclk_ctrl
13	R/W	0	osd_sc_din_osd_alpha_mode : //unsigned,default = 0,osc_sc_din_osd2_alpha_mode, 1: (alpha >= 128) ? alpha -1: alpha, 0: (alpha >=1) ? alpha - 1: alpha.
12	R/W	0	osd_sc_dout_alpha_mode : //unsigned,default = 0,osc_sc_alpha_mode, 1: (alpha >= 128) ? alpha + 1: alpha, 0: (alpha >=1) ? alpha + 1: alpha.
11:4	R/W	0	osd_sc_alpha : //unsigned,default = 0,default alpha for vd1 or vd2 if they are selected as the source
3	R/W	0	osd_sc_path_en : //unsigned,default = 0,osd scaler path enable
2	R/W	0	osd_sc_en : //unsigned,default = 0,osd scaler enable

Table 9-1400 OSD2\_SCI\_WH\_M1 0x3d09

Bit(s)	R/W	Default	Description
28-16	R/W	0x0	OSD scaler input width minus 1
12-0	R/W	0x0	OSD scaler input height minus 1

Table 9-1401 OSD2\_SCO\_H\_START\_END 0x3d0a

Bit(s)	R/W	Default	Description
27-16	R/W	0x0	OSD scaler output horizontal start
11-0	R/W	0x0	OSD scaler output horizontal end

Table 9-1402 OSD2\_SCO\_V\_START\_END 0x3d0b

Bit(s)	R/W	Default	Description
27-16	R/W	0x0	OSD scaler output vertical start
11-0	R/W	0x0	OSD scaler output vertical end

Table 9-1403 OSD2\_SCALE\_COEF\_IDX 0x3d18

Bit(s)	R/W	Default	Description
15	R/W	0x0	Because there are many coefficients used in the vertical filter and horizontal filters, //indirect access the coefficients of vertical filter and horizontal filter is used. //For vertical filter, there are 33x4 coefficients //For horizontal filter, there are 33x4 coefficients //Bit 15 index increment, if bit9 == 1 then (0: index increase 1, 1: index increase 2) else (index increase 2)
14	R/W	0x0	1: read coef through cbus enable, just for debug purpose in case when we wanna check the coef in ram in correct or not
9	R/W	0x0	if true, use 9bit resolution coef, other use 8bit resolution coef
8	R/W	0x0	type of index, 0: vertical coef, 1: horizontal coef
6-0	R/W	0x0	coef index

Table 9-1404 OSD2\_SCALE\_COEF 0x3d19

Bit(s)	R/W	Default	Description
31-0	R/W	0x0	

### 9.2.3.26 VPP OSD\_BLD34 SCALER Registers

Table 9-1405 OSD34\_VSC\_PHASE\_STEP 0x3d20

Bit(s)	R/W	Default	Description
27-0	R/W	0x0100-0000	4.24 format

**Table 9-1406 OSD34\_VSC\_INI\_PHASE 0x3d21**

Bit(s)	R/W	Default	Description
31-16	R/W	0x0	bottom vertical scaler initial phase
15-0	R/W	0x0	top vertical scaler initial phase

**Table 9-1407 OSD34\_VSC\_CTRL0 0x3d22**

Bit(s)	R/W	Default	Description
25	R/W	0	Repeat last line en : 1:enable repeat last line 0:disable repeat last line
24	R/W	0x0	osd vertical Scaler enable
23	R/W	0x0	osd_prog_interlace 0: current field is progressive, 1: current field is interlace
22-21	R/W	0x0	osd_vsc_double_line_mode, bit1, double input width and half input height, bit0, change line buffer becomes 2 lines
20	R/W	0x0	osd_vsc_phase0_always_en
19	R/W	0x0	osd_vsc_nearest_en
17-16	R/W	0x0	osd_vsc_bot_rpt_l0_num
14-11	R/W	0x0	osd_vsc_bot_ini_rcv_num
9-8	R/W	0x0	osd_vsc_top_rpt_l0_num
6-3	R/W	0x0	osd_vsc_top_ini_rcv_num
2-0	R/W	0x0	osd_vsc_bank_length

**Table 9-1408 OSD34\_HSC\_PHASE\_STEP 0x3d23**

Bit(s)	R/W	Default	Description
27-0	R/W	0x0100-0000	4.24 format

**Table 9-1409 OSD34\_HSC\_INI\_PHASE 0x3d24**

Bit(s)	R/W	Default	Description
31-16	R/W	0x0	horizontal scaler initial phase1
15-0	R/W	0x0	horizontal scaler initial phase0

**Table 9-1410 OSD34\_HSC\_CTRL0 0x3d25**

Bit(s)	R/W	Default	Description
22	R/W	0x0	osd horizontal Scaler enable
21	R/W	0x0	osd_hsc_double_pix_mode
20	R/W	0x0	osd_hsc_phase0_always_en
19	R/W	0x0	osd_vsc_nearest_en



Bit(s)	R/W	Default	Description
17-16	R/W	0x0	osd_hsc_rpt_p0_num1
14-11	R/W	0x0	osd_hsc_ini_rcv_num1
9-8	R/W	0x0	osd_hsc_rpt_p0_num0
6-3	R/W	0x0	osd_hsc_ini_rcv_num0
2-0	R/W	0x0	osd_hsc_bank_length

Table 9-1411 OSD34\_HSC\_INI\_PAT\_CTRL 0x3d26

Bit(s)	R/W	Default	Description
15-8	R/W	0x0	for 3D quincunx sub-sampling. pattern, each patten 1 bit, from lsb -> msb
6-4	R/W	0x0	pattern start
2-0	R/W	0x0	pattern end

Table 9-1412 OSD34\_SC\_DUMMY\_DATA 0x3d27

Bit(s)	R/W	Default	Description
31-24	R/W	0x0	componet 0 ,data = (dst_data >> 4) ,so 8 bit in 12bit mode, 6bit in 10bit mode
23-16	R/W	0x0	component 1 ,data = (dst_data >> 4) ,so 8 bit in 12bit mode, 6bit in 10bit mode
15-8	R/W	0x0	component 2 ,data = (dst_data >> 4) ,so 8 bit in 12bit mode, 6bit in 10bit mode
7-0	R/W	0x0	component 3 , alpha

Table 9-1413 OSD34\_SC\_CTRL0 0x3d28

Bit(s)	R/W	Default	Description
27:16	R/W	0	osd_sc_gclk_ctrl : //unsigned,default = 0,osd_sc_gclk_ctrl
13	R/W	0	osd_sc_din_osd_alpha_mode : //unsigned,default = 0,osc_sc_din_osd2_alpha_mode, 1: (alpha >= 128) ? alpha -1: alpha, 0: (alpha >=1) ? alpha - 1: alpha.
12	R/W	0	osd_sc_dout_alpha_mode : //unsigned,default = 0,osc_sc_alpha_mode, 1: (alpha >= 128) ? alpha + 1: alpha, 0: (alpha >=1) ? alpha + 1: alpha.
11:4	R/W	0	osd_sc_alpha : //unsigned,default = 0,default alpha for vd1 or vd2 if they are selected as the source
3	R/W	0	osd_sc_path_en : //unsigned,default = 0,osd scaler path enable
2	R/W	0	osd_sc_en : //unsigned,default = 0,osd scaler enable

Table 9-1414 OSD34\_SCI\_WH\_M1 0x3d29

Bit(s)	R/W	Default	Description
28-16	R/W	0x0	OSD scaler input width minus 1
12-0	R/W	0x0	OSD scaler input height minus 1

Table 9-1415 OSD34\_SCO\_H\_START\_END 0x3d2a

Bit(s)	R/W	Default	Description
27-16	R/W	0x0	OSD scaler output horizontal start
11-0	R/W	0x0	OSD scaler output horizontal end

Table 9-1416 OSD34\_SCO\_V\_START\_END 0x3d2b

Bit(s)	R/W	Default	Description
27-16	R/W	0x0	OSD scaler output vertical start
11-0	R/W	0x0	OSD scaler output vertical end

Table 9-1417 OSD34\_SCALE\_COEF\_IDX 0x3d1e

Bit(s)	R/W	Default	Description
15	R/W	0x0	Because there are many coefficients used in the vertical filter and horizontal filters, //indirect access the coefficients of vertical filter and horizontal filter is used. //For vertical filter, there are 33x4 coefficients //For horizontal filter, there are 33x4 coefficients //Bit 15 index increment, if bit9 == 1 then (0: index increase 1, 1: index increase 2) else (index increase 2)
14	R/W	0x0	1: read coef through cbus enable, just for debug purpose in case when we wanna check the coef in ram in correct or not
9	R/W	0x0	if true, use 9bit resolution coef, other use 8bit resolution coef
8	R/W	0x0	type of index, 0: vertical coef, 1: horizontal coef
6-0	R/W	0x0	coef index

Table 9-1418 OSD34\_SCALE\_COEF 0x3d1f

Bit(s)	R/W	Default	Description
31-0	R/W	0x0	

### 9.2.3.27 VPP VD1 SCALER Registers

Because there are many coefficients used in the vertical filter and horizontal filters, indirect access the coefficients of vertical filter and horizontal filter is used. For vertical filter, there are 33x4 coefficients. For horizontal filter, there are 33x4 coefficients.

Table 9-1419 VPP\_SCALE\_COEF\_IDX 0x1d03

Bit(s)	R/W	Default	Description
15	R/W	0	index_inc : // unsigned , default = 0x0 ,index increment, if bit9 == 1 then (0: index increase 1, 1: index increase 2) else (index increase 2)
14	R/W	0	rd_cbus_coef_en : // unsigned , default = 0x0 ,1: read coef through cbus enable, just for debug purpose in case when we wanna check the coef in ram in correct or not

Bit(s)	R/W	Default	Description
13	R/W	0	vf_sep_coef_en : // unsigned , default = 0x0 ,if true, vertical separated coef enable
9	R/W	0	high_reso_en : // unsigned , default = 0x0 ,if true, use 9bit resolution coef, other use 8bit resolution coef
8:7	R/W	0	type_index : // unsigned , default = 0x0 ,type of index, 00: vertical coef, 01: vertical chroma coef, 10: horizontal coef, 11: reserved
6:0	R/W	0	coef_index : // unsigned , default = 0x0 ,coef index

Table 9-1420 VPP\_SCALE\_COEF 0x1d04

Bit(s)	R/W	Default	Description
31:24	R/W	0	coef0 : //signed , default = 0x0 , coefficients for vertical filter and horizontal filter
23:16	R/W	0	coef1 : //signed , default = 0x0 , coefficients for vertical filter and horizontal filter
15:8	R/W	0	coef2 : //signed , default = 0x0 , coefficients for vertical filter and horizontal filter
7 :0	R/W	0	coef3 : //signed , default = 0x0 , coefficients for vertical filter and horizontal filter

Table 9-1421 VPP\_VSC\_REGION12\_STARTP 0x1d05

Bit(s)	R/W	Default	Description
28:16	R/W	0	region1_startp : //unsigned , default = 0 ,region1 startp
12:0	R/W	0	region2_startp : //unsigned , default = 0 ,region2 startp

Table 9-1422 VPP\_VSC\_REGION34\_STARTP 0x1d06

Bit(s)	R/W	Default	Description
28:16	R/W	0	region3_startp : //unsigned , default = 0x0438,region3 startp
12:0	R/W	0	region4_startp : //unsigned , default = 0x0438,region4 startp

Table 9-1423 VPP\_VSC\_REGION4\_ENDP 0x1d07

Bit(s)	R/W	Default	Description
12:0	R/W	13	region4_endp : //unsigned , default = 13'd1079 ,region4 endp

Table 9-1424 VPP\_VSC\_START\_PHASE\_STEP 0x1d08

Bit(s)	R/W	Default	Description
27:24	R/W	1	integer_part : //unsigned , default = 1,vertical start phase step, (source/dest)* (2^24),integer part of step
23:0	R/W	0	fraction_part : //unsigned , default = 0,vertical start phase step, (source/dest)* (2^24),fraction part of step

**Table 9-1425 VPP\_VSC\_REGION0\_PHASE\_SLOPE 0x1d09**

Bit(s)	R/W	Default	Description
24:0	R/W	0	region0_phase_slope : //signed , default = 0,vertical scaler region0 phase slope, region0 phase slope

**Table 9-1426 VPP\_VSC\_REGION1\_PHASE\_SLOPE 0x1d0a**

Bit(s)	R/W	Default	Description
24:0	R/W	0	region1_phase_slope : //signed , default = 0,region1 phase slope

**Table 9-1427 VPP\_VSC\_REGION3\_PHASE\_SLOPE 0x1d0b**

Bit(s)	R/W	Default	Description
24:0	R/W	0	region3_phase_slope : //signed , default = 0,region3 phase slope

**Table 9-1428 VPP\_VSC\_REGION4\_PHASE\_SLOPE 0x1d0c**

Bit(s)	R/W	Default	Description
24:0	R/W	0	region4_phase_slope : //signed , default = 0,region4 phase slope

**Table 9-1429 VPP\_VSC\_PHASE\_CTRL 0x1d0d**

Bit(s)	R/W	Default	Description
18:17	R/W	0	vsc_double_line_mode : //unsigned , default = 0, double line mode, input/output line width of vscaler becomes 2X, so only 2 line buffer in this case, use for 3D line by line interleave scaling bit1 true, double the input width and half input height, bit0 true, change line buffer 2 lines instead of 4 lines
16	R.O	0	prog_interlace : //unsigned , default = 0,0: progressive output, 1: interlace output
15	R/W	0	vsc_bot_l0_out_en : //unsigned , default = 0,vertical scaler output line0 in advance or not for bottom field
14:13	R/W	1	vsc_bot_rpt_l0_num : //unsigned , default = 1,vertical scaler initial repeat line0 number for bottom field
11:8	R/W	4	vsc_bot_ini_rcv_num : //unsigned , default = 4,vertical scaler initial receiving number for bottom field
7	R/W	0	vsc_top_l0_out_en : //unsigned , default = 0,vertical scaler output line0 in advance or not for top field
6:5	R/W	1	vsc_top_rpt_l0_num : //unsigned , default = 1,vertical scaler initial repeat line0 number for top field
3:0	R/W	4	vsc_top_ini_rcv_num : //unsigned , default = 4,vertical scaler initial receiving number for top field

**Table 9-1430 VPP\_VSC\_INI\_PHASE 0x1d0e**

Bit(s)	R/W	Default	Description
31:16	R/W	0,	//unsigned , default = 0,vertical scaler field initial phase for bottom field Bit 15:0 //unsigned , default = 0,vertical scaler field initial phase for top field

**Table 9-1431 VPP\_HSC\_REGION12\_STARTP 0x1d10**

Bit(s)	R/W	Default	Description
28:16	R/W	0	region1_startp : //unsigned , default = 0,region1 startp
12:0	R/W	0	region2_startp : //unsigned , default = 0,region2 startp

**Table 9-1432 VPP\_HSC\_REGION34\_STARTP 0x1d11**

Bit(s)	R/W	Default	Description
28:16	R/W	0	region3 : startp //unsigned , default = 0x780,region3 startp
12:0	R/W	0	region4 : startp //unsigned , default = 0x780,region4 startp

**Table 9-1433 VPP\_HSC\_REGION4\_ENDP 0x1d12**

Bit(s)	R/W	Default	Description
12:0	R/W	13	region4 : startp //unsigned , default = 13'd1919,region4 startp

horizontal start phase step, (source/dest)\*(2<sup>24</sup>)

**Table 9-1434 VPP\_HSC\_START\_PHASE\_STEP 0x1d13**

Bit(s)	R/W	Default	Description
27:24	R/W	1	integer_part : //unsigned , default = 1,integer part of step
23:0	R/W	0	fraction_part : //unsigned , default = 0,fraction part of step

**Table 9-1435 VPP\_HSC\_REGION0\_PHASE\_SLOPE 0x1d14**

Bit(s)	R/W	Default	Description
24:0	R/W	0	region0_phase_slope : //signed , default = 0,region0 phase slope

**Table 9-1436 VPP\_HSC\_REGION1\_PHASE\_SLOPE 0x1d15**

Bit(s)	R/W	Default	Description
24:0	R/W	0	region0_phase_slope : //signed , default = 0,region1 phase slope

**Table 9-1437 VPP\_HSC\_REGION3\_PHASE\_SLOPE 0x1d16**

Bit(s)	R/W	Default	Description
24:0	R/W	0	region0_phase_slope : //signed , default = 0,region3 phase slope

Table 9-1438 VPP\_HSC\_REGION4\_PHASE\_SLOPE 0x1d17

Bit(s)	R/W	Default	Description
24:0	R/W	0	region0_phase_slope : //signed , default = 0,region4 phase slope

Table 9-1439 VPP\_HSC\_PHASE\_CTRL 0x1d18

Bit(s)	R/W	Default	Description
22:21	R/W	1	hsc_rpt_p0_num0 : //unsigned , default = 1 ,horizontal scaler initial repeat pixel0 number0
19:16	R/W	4	hsc_ini_rcv_num0 : //unsigned , default = 4 ,horizontal scaler initial receiving number0
15:0	R/W	0	hsc_ini_phase0 : //unsigned , default = 0 ,horizontal scaler top field initial phase0

Table 9-1440 VPP\_SC\_MISC 0x1d19

Bit(s)	R/W	Default	Description
24	R/W	0	Repeat last line en : 1:enable repeat last line 0:disable repeat last line
22	R/W	0	hsc_len_div2_en : //unsigned , default = 0 ,if true, divide VSC line length 2 as the HSC input length, othwise VSC length length is the same as the VSC line length just for special usage, more flexibility
21	R/W	0	lbuf_mode : //unsigned , default = 0 ,if true, prevsc uses lin buffer, otherwise prevsc does not use line buffer, it should be same as prevsc_en
20	R/W	0	prehsc_en : //unsigned , default = 0 ,prehsc_en
19	R/W	0	prevsc_en : //unsigned , default = 0 ,prevsc_en
18	R/W	0	vsc_en : //unsigned , default = 0 ,vsc_en
17	R/W	0	hsc_en : //unsigned , default = 0 ,hsc_en
16	R/W	0	sc_top_en : //unsigned , default = 0 ,scale_top_en
15	R/W	0	sc_vd_en : //unsigned , default = 0 ,video1 scale out enable
12	R/W	1	hsc_nonlinear_4region_en : //unsigned , default = 1 ,if true, region0,region4 are nonlinear regions, otherwise they are not scaling regions, for horizontal scaler
10:8	R/W	0	hsc_bank_length : //unsigned , default = 0 ,horizontal scaler bank length
5	R/W	4	vsc_phase_field_mode : //unsigned , default = 4 ,vertical scaler phase field mode, if true, disable the opposite parity line output, more bandwidth needed if output 1080i
4	R/W	0	vsc_nonlinear_4region_en : //unsigned , default = 0 ,if true, region0,region4 are nonlinear regions, otherwise they are not scaling regions, for vertical scaler
2:0	R/W	4	vsc_bank_length : //unsigned , default = 4 ,vertical scaler bank length

**Table 9-1441 VPP\_SCO\_FIFO\_CTRL 0x1d33**

Bit(s)	R/W	Default	Description
27:16	R/W	0	sco_fifo_line_lenm1 : //unsigned , default = 0xffff, scale out fifo line length minus 1
12:0	R/W	0	sco_fifo_size : //unsigned , default = 0x200, scale out fifo size (actually only bit 11:1 is valid, 11:1, max 1024), always even number

for 3D quincunx sub-sampling and horizontal pixel by pixel 3D interleaving

**Table 9-1442 VPP\_HSC\_PHASE\_CTRL1 0x1d34**

Bit(s)	R/W	Default	Description
27:24	R/W	0	prehsc_mode : //unsigned , default = 0,prehsc_mode, bit 3:2, prehsc odd line interp mode, bit 1:0, prehsc even line interp mode, each 2bit, 00: pix0+pix1/2, average, 01: pix1, 10: pix0
23	R/W	0	hsc_double_pix_mode : //unsigned , default = 0, horizontal scaler double pixel mode
22:21	R/W	1	hsc_rpt_p0_num1 : //unsigned , default = 1, horizontal scaler initial repeat pixel0 number1
19:16	R/W	4	hsc_ini_rcv_num1 : //unsigned , default = 4, horizontal scaler initial receiving number1
15:0	R/W	0	hsc_ini_phase1 : //unsigned , default = 0, horizontal scaler top field initial phase1

**Table 9-1443 for 3D quincunx sub-sampling VPP\_HSC\_INI\_PAT\_CTRL 0x1d35**

Bit(s)	R/W	Default	Description
31:24	R/W	0	prehsc_pattern : //unsigned , default = 0, prehsc pattern, each patten 1 bit, from lsb -> msb
22:20	R/W	0	prehsc_pat_star : //unsigned , default = 0, prehsc pattern start
18:16	R/W	0	prehsc_pat_end : //unsigned , default = 0, prehsc pattern end
15:8	R/W	0	hsc_pattern : //unsigned , default = 0, hsc pattern, each patten 1 bit, from lsb -> msb
6:4	R/W	0	hsc_pat_start : //unsigned , default = 0, hsc pattern start
2:0	R/W	0	hsc_pat_end : //unsigned , default = 0, hsc pattern end

**Table 9-1444 VPP\_SC\_GCLK\_CTRL 0x1d35**

Bit(s)	R/W	Default	Description
15:0	R/W	0	vpp_sc_gclk_ctrl : //unsigned , default = 0 ,scale clock gate

### 9.2.3.28 VPP VD2 SCALER Registers

Because there are many coefficients used in the vertical filter and horizontal filters, indirect access the coefficients of vertical filter and horizontal filter is used. For vertical filter, there are 33x4 coefficients. For horizontal filter, there are 33x4 coefficients.

**Table 9-1445 VD2\_SCALE\_COEF\_IDX 0x3943**

Bit(s)	R/W	Default	Description
15	R/W	0	index_inc : // unsigned , default = 0x0 ,index increment, if bit9 == 1 then (0: index increase 1, 1: index increase 2) else (index increase 2)
14	R/W	0	rd_cbus_coef_en : // unsigned , default = 0x0 ,1: read coef through cbus enable, just for debug purpose in case when we wanna check the coef in ram in correct or not
13	R/W	0	vf_sep_coef_en : // unsigned , default = 0x0 ,if true, vertical separated coef enable
9	R/W	0	high_reso_en : // unsigned , default = 0x0 ,if true, use 9bit resolution coef, other use 8bit resolution coef
8:7	R/W	0	type_index : // unsigned , default = 0x0 ,type of index, 00: vertical coef, 01: vertical chroma coef: 10: horizontal coef, 11: reserved
6:0	R/W	0	coef_index : // unsigned , default = 0x0 ,coef index

**Table 9-1446 VD2\_SCALE\_COEF 0x3944**

Bit(s)	R/W	Default	Description
31:24	R/W	0	coef0 : //signed , default = 0x0 , coefficients for vertical filter and horizontal filter
23:16	R/W	0	coef1 : //signed , default = 0x0 , coefficients for vertical filter and horizontal filter
15:8	R/W	0	coef2 : //signed , default = 0x0 , coefficients for vertical filter and horizontal filter
7 :0	R/W	0	coef3 : //signed , default = 0x0 , coefficients for vertical filter and horizontal filter

**Table 9-1447 VD2\_VSC\_REGION12\_STARTP 0x3945**

Bit(s)	R/W	Default	Description
28:16	R/W	0	region1_startp : //unsigned , default = 0 ,region1 startp
12:0	R/W	0	region2_startp : //unsigned , default = 0 ,region2 startp

**Table 9-1448 VD2\_VSC\_REGION34\_STARTP 0x3946**

Bit(s)	R/W	Default	Description
28:16	R/W	0x0438	region3_startp : //unsigned , default = 0x0438,region3 startp
12:0	R/W	0x0438	region4_startp : //unsigned , default = 0x0438,region4 startp

**Table 9-1449 VD2\_VSC\_REGION4\_ENDP 0x3947**

Bit(s)	R/W	Default	Description
12:0	R/W	13	region4_endp : //unsigned , default = 13'd1079 ,region4 endp



**Table 9-1450 VD2\_VSC\_START\_PHASE\_STEP 0x3948**

Bit(s)	R/W	Default	Description
27:24	R/W	1	integer_part : //unsigned , default = 1,vertical start phase step, (source/dest)* (2^24),integer part of step
23:0	R/W	0	fraction_part : //unsigned , default = 0,vertical start phase step, (source/dest)* (2^24),fraction part of step

**Table 9-1451 VD2\_VSC\_REGION0\_PHASE\_SLOPE 0x3949**

Bit(s)	R/W	Default	Description
24:0	R/W	0	region0_phase_slope : //signed , default = 0,vertical scaler region0 phase slope, region0 phase slope

**Table 9-1452 VD2\_VSC\_REGION1\_PHASE\_SLOPE 0x394a**

Bit(s)	R/W	Default	Description
24:0	R/W	0	region1_phase_slope : //signed , default = 0,region1 phase slope

**Table 9-1453 VD2\_VSC\_REGION3\_PHASE\_SLOPE 0x394b**

Bit(s)	R/W	Default	Description
24:0	R/W	0	region3_phase_slope : //signed , default = 0,region3 phase slope

**Table 9-1454 VD2\_VSC\_REGION4\_PHASE\_SLOPE 0x394c**

Bit(s)	R/W	Default	Description
24:0	R/W	0	region4_phase_slope : //signed , default = 0,region4 phase slope

**Table 9-1455 VD2\_VSC\_PHASE\_CTRL 0x394d**

Bit(s)	R/W	Default	Description
18:17	R/W	0	vsc_double_line_mode : //unsigned , default = 0, double line mode, input/output line width of vscler becomes 2X, so only 2 line buffer in this case, use for 3D line by line interleave scaling bit1 true, double the input width and half input height, bit0 true, change line buffer 2 lines instead of 4 lines
16	R.O	0	prog_interlace : //unsigned , default = 0,0: progressive output, 1: interlace output
15	R/W	0	vsc_bot_l0_out_en : //unsigned , default = 0,vertical scaler output line0 in advance or not for bottom field
14:13	R/W	1	vsc_bot_rpt_l0_num : //unsigned , default = 1,vertical scaler initial repeat line0 number for bottom field
11:8	R/W	4	vsc_bot_ini_rcv_num : //unsigned , default = 4,vertical scaler initial receiving number for bottom field
7	R/W	0	vsc_top_l0_out_en : //unsigned , default = 0,vertical scaler output line0 in advance or not for top field

Bit(s)	R/W	Default	Description
6:5	R/W	1	vsc_top_rpt_l0_num : //unsigned , default = 1,vertical scaler initial repeat line0 number for top field
3:0	R/W	4	vsc_top_ini_rcv_num : //unsigned , default = 4,vertical scaler initial receiving number for top field

Table 9-1456 VD2\_VSC\_INI\_PHASE 0x394e

Bit(s)	R/W	Default	Description
31:16	R/W	0,	//unsigned , default = 0,vertical scaler field initial phase for bottom field Bit 15:0 //unsigned , default = 0,vertical scaler field initial phase for top field

Table 9-1457 VD2\_HSC\_REGION12\_STARTP 0x394f

Bit(s)	R/W	Default	Description
28:16	R/W	0	region1_startp : //unsigned , default = 0,region1 startp
12:0	R/W	0	region2_startp : //unsigned , default = 0,region2 startp

Table 9-1458 VD2\_HSC\_REGION34\_STARTP 0x3950

Bit(s)	R/W	Default	Description
28:16	R/W	0	region3 : startp //unsigned , default = 0x780,region3 startp
12:0	R/W	0	region4 : startp //unsigned , default = 0x780,region4 startp

Table 9-1459 VD2\_HSC\_REGION4\_ENDP 0x3951

Bit(s)	R/W	Default	Description
12:0	R/W	13	region4 : startp //unsigned , default = 13'd1919,region4 startp

horizontal start phase step,  $(\text{source/dest}) \cdot (2^{24})$

Table 9-1460 VD2\_HSC\_START\_PHASE\_STEP 0x3952

Bit(s)	R/W	Default	Description
27:24	R/W	1	integer_part : //unsigned , default = 1,integer part of step
23:0	R/W	0	fraction_part : //unsigned , default = 0,fraction part of step

Table 9-1461 VD2\_HSC\_REGION0\_PHASE\_SLOPE 0x3953

Bit(s)	R/W	Default	Description
24:0	R/W	0	region0_phase_slope : //signed , default = 0,region0 phase slope

**Table 9-1462 VD2\_HSC\_REGION1\_PHASE\_SLOPE 0x3954**

Bit(s)	R/W	Default	Description
24:0	R/W	0	region0_phase_slope : //signed , default = 0,region1 phase slope

**Table 9-1463 VD2\_HSC\_REGION3\_PHASE\_SLOPE 0x3955**

Bit(s)	R/W	Default	Description
24:0	R/W	0	region0_phase_slope : //signed , default = 0,region3 phase slope

**Table 9-1464 VD2\_HSC\_REGION4\_PHASE\_SLOPE 0x3956**

Bit(s)	R/W	Default	Description
24:0	R/W	0	region0_phase_slope : //signed , default = 0,region4 phase slope

**Table 9-1465 VD2\_HSC\_PHASE\_CTRL 0x3957**

Bit(s)	R/W	Default	Description
22:21	R/W	1	hsc_rpt_p0_num0 : //unsigned , default = 1 ,horizontal scaler initial repeat pixel0 number0
19:16	R/W	4	hsc_ini_rcv_num0 : //unsigned , default = 4 ,horizontal scaler initial receiving number0
15:0	R/W	0	hsc_ini_phase0 : //unsigned , default = 0 ,horizontal scaler top field initial phase0

**Table 9-1466 VD2\_SC\_MISC 0x3958**

Bit(s)	R/W	Default	Description
24	R/W	0	Repeat last line en : 1:enable repeat last line 0:disable repeat last line
22	R/W	0	hsc_len_div2_en : //unsigned , default = 0 ,if true, divide VSC line length 2 as the HSC input length, othwise VSC length length is the same as the VSC line length just for special usage, more flexibility
21	R/W	0	lbuf_mode : //unsigned , default = 0 ,if true, prevsc uses lin buffer, otherwise prevsc does not use line buffer, it should be same as prevsc_en
20	R/W	0	prehsc_en : //unsigned , default = 0 ,prehsc_en
19	R/W	0	prevsc_en : //unsigned , default = 0 ,prevsc_en
18	R/W	0	vsc_en : //unsigned , default = 0 ,vsc_en
17	R/W	0	hsc_en : //unsigned , default = 0 ,hsc_en
16	R/W	0	sc_top_en : //unsigned , default = 0 ,scale_top_en
15	R/W	0	sc_vd_en : //unsigned , default = 0 ,video1 scale out enable
12	R/W	1	hsc_nonlinear_4region_en : //unsigned , default = 1 ,if true, region0,region4 are nonlinear regions, otherwise they are not scaling regions, for horizontal scaler
10:8	R/W	0	hsc_bank_length : //unsigned , default = 0 ,horizontal scaler bank length
5	R/W	4	vsc_phase_field_mode : //unsigned , default = 4 ,vertical scaler phase field mode, if true, disable the opposite parity line output, more bandwidth needed if output 1080i

Bit(s)	R/W	Default	Description
4	R/W	0	vsc_nonlinear_4region_en : //unsigned , default = 0 ,if true, region0,region4 are nonlinear regions, otherwise they are not scaling regions, for vertical scaler
2:0	R/W	4	vsc_bank_length : //unsigned , default = 4 ,vertical scaler bank length

Table 9-1467 VD2\_SCO\_FIFO\_CTRL 0x3959

Bit(s)	R/W	Default	Description
27:16	R/W	0	sco_fifo_line_lenm1 : //unsigned , default = 0xff, scale out fifo line length minus 1
12:0	R/W	0	sco_fifo_size : //unsigned , default = 0x200, scale out fifo size (actually only bit 11:1 is valid, 11:1, max 1024), always even number

Table 9-1468 for 3D quincunx sub-sampling and horizontal pixel by pixel 3D interleaving VD2\_HSC\_PHASE\_CTRL1 0x395a

Bit(s)	R/W	Default	Description
27:24	R/W	0	prehsc_mode : //unsigned , default = 0,prehsc_mode, bit 3:2, prehsc odd line interp mode, bit 1:0, prehsc even line interp mode, each 2bit, 00: pix0+pix1/2, average, 01: pix1, 10: pix0
23	R/W	0	hsc_double_pix_mode : //unsigned , default = 0,horizontal scaler double pixel mode
22:21	R/W	1	hsc_rpt_p0_num1 : //unsigned , default = 1,horizontal scaler initial repeat pixel0 number1
19:16	R/W	4	hsc_ini_rcv_num1 : //unsigned , default = 4,horizontal scaler initial receiving number1
15:0	R/W	0	hsc_ini_phase1 : //unsigned , default = 0,horizontal scaler top field initial phase1

Table 9-1469 for 3D quincunx sub-sampling VD2\_HSC\_INI\_PAT\_CTRL 0x395b

Bit(s)	R/W	Default	Description
31:24	R/W	0	prehsc_pattern : //unsigned , default = 0, prehsc pattern, each patten 1 bit, from lsb -> msb
22:20	R/W	0	prehsc_pat_star : //unsigned , default = 0, prehsc pattern start
18:16	R/W	0	prehsc_pat_end : //unsigned , default = 0, prehsc pattern end
15:8	R/W	0	hsc_pattern : //unsigned , default = 0, hsc pattern, each patten 1 bit, from lsb -> msb
6:4	R/W	0	hsc_pat_start : //unsigned , default = 0, hsc pattern start
2:0	R/W	0	hsc_pat_end : //unsigned , default = 0, hsc pattern end

Table 9-1470 VD2\_SC\_GCLK\_CTRL 0x395c

Bit(s)	R/W	Default	Description
15:0	R/W	0	vpp_sc_gclk_ctrl : //unsigned , default = 0 ,scale clock gate

### 9.2.3.29 Supper Scale/ Sharpness Registers

**Table 9-1471 SRSHARP0\_SHARP\_HVSIZE 0x3e00**

Bit(s)	R/W	Default	Description
28:16	R/W	0d1920	reg_pknr_hsize : . unsigned , default = 1920
12: 0	R/W	0d1080	reg_pknr_vsize : . unsigned , default = 1080

**Table 9-1472 SRSHARP0\_SHARP\_HVBLANK\_NUM 0x3e01**

Bit(s)	R/W	Default	Description
23: 16	R/W	0d8	reg_deband_hblank : . unsigned , default = 8
15: 8	R/W	0d20	reg_pknr_hblank_num : . unsigned , default = 20
7: 0	R/W	0d60	reg_pknr_vblank_num : . unsigned , default = 60

**Table 9-1473 SRSHARP0\_NR\_GAUSSIAN\_MODE 0x3e02**

Bit(s)	R/W	Default	Description
4	R/W	0d1	reg_nr_gau_ymode : : 0 3x3 filter; 1: 5x5 filter . unsigned , default = 1
0	R/W	0d1	reg_nr_gau_cmode : : 0 3x3 filter; 1: 5x5 filter . unsigned , default = 1

**Table 9-1474 SRSHARP0\_PK\_CON\_2CIRHPGAIN\_TH\_RATE 0x3e05**

Bit(s)	R/W	Default	Description
31:24	R/W	0d25	reg_pk_cirhpcon2gain0 : : threshold0 of curve to map hpcon to hpgain for circle hp filter (all 8 direction same). 0~255.. unsigned , default = 25
23:16	R/W	0d60	reg_pk_cirhpcon2gain1 : : threshold1 of curve to map hpcon to hpgain for circle hp filter (all 8 direction same). 0~255.. unsigned , default = 60
15: 8	R/W	0d80	reg_pk_cirhpcon2gain5 : : rate0 (for hpcon<th0) of curve to map hpcon to hpgain for circle hp filter (all 8 direction same). 0~255.. unsigned , default = 80
7: 0	R/W	0d20	reg_pk_cirhpcon2gain6 : : rate1 (for hpcon>th1) of curve to map hpcon to hpgain for circle hp filter (all 8 direction same). 0~255.. unsigned , default = 20

**Table 9-1475 SRSHARP0\_PK\_CON\_2CIRHPGAIN\_LIMIT 0x3e06**

Bit(s)	R/W	Default	Description
31:24	R/W	0d96	reg_pk_cirhpcon2gain2 : : level limit(for hpcon<th0) of curve to map hpcon to hpgain for circle hp filter (all 8 direction same). 0~255.. unsigned , default = 96
23:16	R/W	0d96	reg_pk_cirhpcon2gain3 : : level limit(for th0<hpcon<th1) of curve to map hpcon to hpgain for circle hp filter (all 8 direction same). 0~255.. unsigned , default = 96
15: 8	R/W	0d5	reg_pk_cirhpcon2gain4 : : level limit(for hpcon>th1) of curve to map hpcon to hpgain for circle hp filter (all 8 direction same). 0~255.. unsigned , default = 5

**Table 9-1476 SRSHARP0\_PK\_CON\_2CIRBPGAIN\_TH\_RATE 0x3e07**

Bit(s)	R/W	Default	Description
31:24	R/W	0d20	reg_pk_cirbpcon2gain0 : : threshold0 of curve to map bpcon to bpgain for circle bp filter (all 8 direction same). 0~255.. unsigned , default = 20
23:16	R/W	0d50	reg_pk_cirbpcon2gain1 : : threshold1 of curve to map bpcon to bpgain for circle bp filter (all 8 direction same).. unsigned , default = 50
15: 8	R/W	0d50	reg_pk_cirbpcon2gain5 : : rate0 (for bpcon<th0) of curve to map bpcon to bpgain for circle bp filter (all 8 direction same). 0~255.. unsigned , default = 50
7: 0	R/W	0d25	reg_pk_cirbpcon2gain6 : : rate1 (for bpcon>th1) of curve to map bpcon to bpgain for circle bp filter (all 8 direction same). 0~255.. unsigned , default = 25

**Table 9-1477 SRSHARP0\_PK\_CON\_2CIRBPGAIN\_LIMIT 0x3e08**

Bit(s)	R/W	Default	Description
31:24	R/W	0d40	reg_pk_cirbpcon2gain2 : : level limit(for bpcon<th0) of curve to map bpcon to bpgain for circle bp filter (all 8 direction same). 0~255.. unsigned , default = 40
23:16	R/W	0d40	reg_pk_cirbpcon2gain3 : : level limit(for th0<bpcon<th1) of curve to map bpcon to bpgain for circle bp filter (all 8 direction same). 0~255.. unsigned , default = 40
15: 8	R/W	0d5	reg_pk_cirbpcon2gain4 : : level limit(for bpcon>th1) of curve to map bpcon to bpgain for circle bp filter (all 8 direction same). 0~255.. unsigned , default = 5

**Table 9-1478 SRSHARP0\_PK\_CON\_2DRTHPGAIN\_TH\_RATE 0x3e09**

Bit(s)	R/W	Default	Description
31:24	R/W	0d25	reg_pk_drthpcon2gain0 : : threshold0 of curve to map hpcon to hpgain for directional hp filter (best direction). 0~255.. unsigned , default = 25
23:16	R/W	0d60	reg_pk_drthpcon2gain1 : : threshold1 of curve to map hpcon to hpgain for directional hp filter (best direction). 0~255.. unsigned , default = 60
15: 8	R/W	0d80	reg_pk_drthpcon2gain5 : : rate0 (for hpcon<th0) of curve to map hpcon to hpgain for directional hp filter (best direction). 0~255.. unsigned , default = 80
7: 0	R/W	0d20	reg_pk_drthpcon2gain6 : : rate1 (for hpcon>th1) of curve to map hpcon to hpgain for directional hp filter (best direction). 0~255.. unsigned , default = 20

**Table 9-1479 SRSHARP0\_PK\_CON\_2DRTHPGAIN\_LIMIT 0x3e0a**

Bit(s)	R/W	Default	Description
31:24	R/W	0d90	reg_pk_drthpcon2gain2 : : level limit(for hpcon<th0) of curve to map hpcon to hpgain for directional hp filter (best direction).. unsigned , default = 90
23:16	R/W	0d96	reg_pk_drthpcon2gain3 : : level limit(for th0<hpcon<th1) of curve to map hpcon to hpgain for directional hp filter (best direction). 0~255.. unsigned , default = 96
15: 8	R/W	0d5	reg_pk_drthpcon2gain4 : : level limit(for hpcon>th1) of curve to map hpcon to hpgain for directional hp filter (best direction). 0~255.. unsigned , default = 5

**Table 9-1480 SRSHARP0\_PK\_CON\_2DRTBPGAIN\_TH\_RATE 0x3e0b**

Bit(s)	R/W	Default	Description
31:24	R/W	0d20	reg_pk_drtbpcn2gain0 : : threshold0 of curve to map bpcon to bpgain for directional bp filter (best direction). 0~255.. unsigned , default = 20
23:16	R/W	0d50	reg_pk_drtbpcn2gain1 : : threshold1 of curve to map bpcon to bpgain for directional bp filter (best direction). 0~255.. unsigned , default = 50
15: 8	R/W	0d50	reg_pk_drtbpcn2gain5 : : rate0 (for bpcon<th0) of curve to map bpcon to bpgain for directional bp filter (best direction). 0~255.. unsigned , default = 50
7: 0	R/W	0d25	reg_pk_drtbpcn2gain6 : : rate1 (for bpcon>th1) of curve to map bpcon to bpgain for directional bp filter (best direction). 0~255.. unsigned , default = 25

**Table 9-1481 SRSHARP0\_PK\_CON\_2DRTBPGAIN\_LIMIT 0x3e0c**

Bit(s)	R/W	Default	Description
31:24	R/W	0d40	reg_pk_drtbpcn2gain2 : : level limit(for bpcon<th0) of curve to map bpcon to bpgain for directional bp filter (best direction). 0~255.. unsigned , default = 40
23:16	R/W	0d40	reg_pk_drtbpcn2gain3 : : level limit(for th0<bpcon<th1) of curve to map bpcon to bpgain for directional bp filter (best direction). 0~255.. unsigned , default = 40
15: 8	R/W	0d5	reg_pk_drtbpcn2gain4 : : level limit(for bpcon>th1) of curve to map bpcon to bpgain for directional bp filter (best direction). 0~255.. unsigned , default = 5

**Table 9-1482 SRSHARP0\_PK\_CIRFB\_LPF\_MODE 0x3e0d**

Bit(s)	R/W	Default	Description
29:28	R/W	0d1	reg_cirhp_horz_mode : : no horz filter on HP; 1: [1 2 1]/4; 2/3: [1 2 2 2 1]/8. unsigned , default = 1
25:24	R/W	0d1	reg_cirhp_vert_mode : : no vert filter on HP; 1: [1 2 1]/4; 2/3: [1 2 2 2 1]/8. unsigned , default = 1
21:20	R/W	0d1	reg_cirhp_diag_mode : : filter on HP; 1: [1 2 1]/4; . unsigned , default = 1
13:12	R/W	0d1	reg_cirbp_horz_mode : : no horz filter on BP; 1: [1 2 1]/4; 2/3: [1 2 2 2 1]/8. unsigned , default = 1
9: 8	R/W	0d1	reg_cirbp_vert_mode : : no vert filter on BP; 1: [1 2 1]/4; 2/3: [1 2 2 2 1]/8. unsigned , default = 1
5: 4	R/W	0d1	reg_cirbp_diag_mode : : filter on BP; 1: [1 2 1]/4; . unsigned , default = 1

**Table 9-1483 SRSHARP0\_PK\_DRTFB\_LPF\_MODE 0x3e0e**

Bit(s)	R/W	Default	Description
29:28	R/W	0d1	reg_drthp_horz_mode : : no horz filter on HP; 1: [1 2 1]/4; 2/3: [1 2 2 2 1]/8 2 . unsigned , default = 1
25:24	R/W	0d1	reg_drthp_vert_mode : : no vert filter on HP; 1: [1 2 1]/4; 2/3: [1 2 2 2 1]/8 2 . unsigned , default = 1
21:20	R/W	0d1	reg_drthp_diag_mode : : filter on HP; 1: [1 2 1]/4; 1 . unsigned , default = 1
13:12	R/W	0d1	reg_drtbp_horz_mode : : no horz filter on BP; 1: [1 2 1]/4; 2/3: [1 2 2 2 1]/8 2 . unsigned , default = 1

Bit(s)	R/W	Default	Description
9: 8	R/W	0d1	reg_drtbp_vert_mode :: no vert filter on BP; 1: [1 2 1]/4; 2/3: [1 2 2 2 1]/8 2 . unsigned , default = 1
5: 4	R/W	0d1	reg_drtbp_diag_mode :: filter on BP; 1: [1 2 1]/4; 1 . unsigned , default = 1

**Table 9-1484 SRSHARP0\_PK\_CIRFB\_HP\_CORING 0x3e0f**

Bit(s)	R/W	Default	Description
21:16	R/W	0d4	reg_cirhp_horz_core :: coring of HP for Horz. unsigned , default = 4
13: 8	R/W	0d4	reg_cirhp_vert_core :: coring of HP for Vert. unsigned , default = 4
5: 0	R/W	0d4	reg_cirhp_diag_core :: coring of HP for Diag. unsigned , default = 4

**Table 9-1485 SRSHARP0\_PK\_CIRFB\_BP\_CORING 0x3e10**

Bit(s)	R/W	Default	Description
21:16	R/W	0d4	reg_cirbp_horz_core :: coring of HP for Horz. unsigned , default = 4
13: 8	R/W	0d4	reg_cirbp_vert_core :: coring of HP for Vert. unsigned , default = 4
5: 0	R/W	0d4	reg_cirbp_diag_core :: coring of HP for Diag. unsigned , default = 4

**Table 9-1486 SRSHARP0\_PK\_DRTFB\_HP\_CORING 0x3e11**

Bit(s)	R/W	Default	Description
21:16	R/W	0d4	reg_drthp_horz_core :: coring of HP for Horz. unsigned , default = 4
13: 8	R/W	0d4	reg_drthp_vert_core :: coring of HP for Vert. unsigned , default = 4
5: 0	R/W	0d4	reg_drthp_diag_core :: coring of HP for Diag. unsigned , default = 4

**Table 9-1487 SRSHARP0\_PK\_DRTFB\_BP\_CORING 0x3e12**

Bit(s)	R/W	Default	Description
21:16	R/W	0d4	reg_drtbp_horz_core :: coring of HP for Horz. unsigned , default = 4
13: 8	R/W	0d4	reg_drtbp_vert_core :: coring of HP for Vert. unsigned , default = 4
5: 0	R/W	0d4	reg_drtbp_diag_core :: coring of HP for Diag. unsigned , default = 4

**Table 9-1488 SRSHARP0\_PK\_CIRFB\_BLEND\_GAIN 0x3e13**

Bit(s)	R/W	Default	Description
31:28	R/W	0d8	reg_hp_cir_hgain :: normalized 8 as '1' . unsigned , default = 8
27:24	R/W	0d8	reg_hp_cir_vgain :: normalized 8 as '1' . unsigned , default = 8
23:20	R/W	0d8	reg_hp_cir_dgain :: normalized 8 as '1' . unsigned , default = 8
15:12	R/W	0d8	reg_bp_cir_hgain :: normalized 8 as '1' . unsigned , default = 8



Bit(s)	R/W	Default	Description
11: 8	R/W	0d8	reg_bp_cir_vgain :: normalized 8 as '1'. unsigned , default = 8
7: 4	R/W	0d8	reg_bp_cir_dgain :: normalized 8 as '1'. unsigned , default = 8

Table 9-1489 SRSHARP0\_NR\_ALPY\_SSD\_GAIN\_OFST 0x3e14

Bit(s)	R/W	Default	Description
15: 8	R/W	0d16	reg_nr_alp0_ssd_gain :: gain to max ssd normalized 16 as '1'. unsigned , default = 16
5: 0	R/W	0x0	reg_nr_alp0_ssd_ofst :: offset to ssd before dividing to min_err . signed , default = -2

Table 9-1490 SRSHARP0\_NR\_ALP0Y\_ERR2CURV\_TH\_RATE 0x3e15

Bit(s)	R/W	Default	Description
31:24	R/W	0d10	reg_nr_alp0_minerr_ypar0 :: threshold0 of curve to map mierr to alp0 for luma channel, this will be set value of flat region mierr that no need blur. 0~255.. unsigned , default = 10
23:16	R/W	0d25	reg_nr_alp0_minerr_ypar1 :: threshold1 of curve to map mierr to alp0 for luma channel, this will be set value of texture region mierr that can not blur.. unsigned , default = 25
15: 8	R/W	0d80	reg_nr_alp0_minerr_ypar5 :: rate0 (for mierr<th0) of curve to map mierr to alp0 for luma channel. the larger of the value, the deep of the slope. 0~255.. unsigned , default = 80
7: 0	R/W	0d64	reg_nr_alp0_minerr_ypar6 :: rate1 (for mierr>th1) of curve to map mierr to alp0 for luma channel. the larger of the value, the deep of the slope. 0~255.. unsigned , default = 64

Table 9-1491 SRSHARP0\_NR\_ALP0Y\_ERR2CURV\_LIMIT 0x3e16

Bit(s)	R/W	Default	Description
31:24	R/W	0d63	reg_nr_alp0_minerr_ypar2 :: level limit(for mierr<th0) of curve to map mierr to alp0 for luma channel, this will be set to alp0 that we can do for flat region. 0~255.. unsigned , default = 63
23:16	R/W	0d0	reg_nr_alp0_minerr_ypar3 :: level limit(for th0<mierr<th1) of curve to map mierr to alp0 for luma channel, this will be set to alp0 that we can do for misc region. 0~255.. unsigned , default = 0
15: 8	R/W	0d63	reg_nr_alp0_minerr_ypar4 :: level limit(for mierr>th1) of curve to map mierr to alp0 for luma channel, this will be set to alp0 that we can do for texture region. 0~255.. unsigned , default = 63

Table 9-1492 SRSHARP0\_NR\_ALP0C\_ERR2CURV\_TH\_RATE 0x3e17

Bit(s)	R/W	Default	Description
31:24	R/W	0d10	reg_nr_alp0_minerr_cpar0 :: threshold0 of curve to map mierr to alp0 for chroma channel, this will be set value of flat region mierr that no need blur.. unsigned , default = 10
23:16	R/W	0d25	reg_nr_alp0_minerr_cpar1 :: threshold1 of curve to map mierr to alp0 for chroma channel, this will be set value of texture region mierr that can not blur.. unsigned , default = 25

Bit(s)	R/W	Default	Description
15: 8	R/W	0d80	reg_nr_alp0_minerr_cpar5 : : rate0 (for mierr<th0) of curve to map mierr to alp0 for chroma channel. the larger of the value, the deep of the slope. 0~255.. unsigned , default = 80
7: 0	R/W	0d64	reg_nr_alp0_minerr_cpar6 : : rate1 (for mierr>th1) of curve to map mierr to alp0 for chroma channel. the larger of the value, the deep of the slope. 0~255.. unsigned , default = 64

Table 9-1493 SRSHARP0\_NR\_ALP0C\_ERR2CURV\_LIMIT 0x3e18

Bit(s)	R/W	Default	Description
31:24	R/W	0d63	reg_nr_alp0_minerr_cpar2 : : level limit(for mierr<th0) of curve to map mierr to alp0 for chroma channel, this will be set to alp0 that we can do for flat region. 0~255.. unsigned , default = 63
23:16	R/W	0d0	reg_nr_alp0_minerr_cpar3 : : level limit(for th0<mierr<th1) of curve to map mierr to alp0 for chroma channel, this will be set to alp0 that we can do for misc region. 0~255.. unsigned , default = 0
15: 8	R/W	0d63	reg_nr_alp0_minerr_cpar4 : : level limit(for mierr>th1) of curve to map mierr to alp0 for chroma channel, this will be set to alp0 that we can do for texture region. 0~255.. unsigned , default = 63

Table 9-1494 SRSHARP0\_NR\_ALP0\_MIN\_MAX 0x3e19

Bit(s)	R/W	Default	Description
29:24	R/W	0d2	reg_nr_alp0_ymin : : normalized to 64 as '1' . unsigned , default = 2
21:16	R/W	0d63	reg_nr_alp0_ymax : : normalized to 64 as '1' . unsigned , default = 63
13: 8	R/W	0d2	reg_nr_alp0_cmin : : normalized to 64 as '1' . unsigned , default = 2
5: 0	R/W	0d63	reg_nr_alp0_cmax : : normalized to 64 as '1' . unsigned , default = 63

Table 9-1495 SRSHARP0\_NR\_ALP1\_MIERR\_CORING 0x3e1a

Bit(s)	R/W	Default	Description
16	R/W	0d0	reg_nr_alp1_maxerr_mode : : 0 max err; 1: xerr . unsigned , default = 0
13: 8	R/W	0d0	reg_nr_alp1_core_rate : : normalized 64 as "1" . unsigned , default = 0
5: 0	R/W	0d3	reg_nr_alp1_core_ofst : : normalized 64 as "1". signed , default = 3

Table 9-1496 SRSHARP0\_NR\_ALP1\_ERR2CURV\_TH\_RATE 0x3e1b

Bit(s)	R/W	Default	Description
31:24	R/W	0d0	reg_nr_alp1_minerr_par0 : : threshold0 of curve to map mierr to alp1 for luma/ chroma channel, this will be set value of flat region mierr that no need directional NR. 0~255.. unsigned , default = 0
23:16	R/W	0d24	reg_nr_alp1_minerr_par1 : : threshold1 of curve to map mierr to alp1 for luma/ chroma channel, this will be set value of texture region mierr that can not do directional NR. 0~255.. unsigned , default = 24

Bit(s)	R/W	Default	Description
15: 8	R/W	0d0	reg_nr_alp1_minerr_par5 :: rate0 (for mierr<th0) of curve to map mierr to alp1 for luma/chroma channel. the larger of the value, the deep of the slope.. unsigned , default = 0
7: 0	R/W	0d20	reg_nr_alp1_minerr_par6 :: rate1 (for mierr>th1) of curve to map mierr to alp1 for luma/chroma channel. the larger of the value, the deep of the slope. 0~255. unsigned , default = 20

Table 9-1497 SRSHARP0\_NR\_ALP1\_ERR2CURV\_LIMIT 0x3e1c

Bit(s)	R/W	Default	Description
31:24	R/W	0d0	reg_nr_alp1_minerr_par2 :: level limit(for mierr<th0) of curve to map mierr to alp1 for luma/chroma channel, this will be set to alp1 that we can do for flat region. 0~255.. unsigned , default = 0
23:16	R/W	0d16	reg_nr_alp1_minerr_par3 :: level limit(for th0<mierr<th1) of curve to map mierr to alp1 for luma/chroma channel, this will be set to alp1 that we can do for misc region. 0~255.. unsigned , default = 16
15: 8	R/W	0d63	reg_nr_alp1_minerr_par4 :: level limit(for mierr>th1) of curve to map mierr to alp1 for luma/chroma channel, this will be set to alp1 that we can do for texture region. 0~255.255 before. unsigned , default = 63

Table 9-1498 SRSHARP0\_NR\_ALP1\_MIN\_MAX 0x3e1d

Bit(s)	R/W	Default	Description
29:24	R/W	0d0	reg_nr_alp1_ymin :: normalized to 64 as '1' . unsigned , default = 0
21:16	R/W	0d63	reg_nr_alp1_ymax :: normalized to 64 as '1' . unsigned , default = 63
13: 8	R/W	0d0	reg_nr_alp1_cmin :: normalized to 64 as '1' . unsigned , default = 0
5: 0	R/W	0d63	reg_nr_alp1_cmax :: normalized to 64 as '1' . unsigned , default = 63

Table 9-1499 SRSHARP0\_PK\_ALP2\_MIERR\_CORING 0x3e1e

Bit(s)	R/W	Default	Description
16	R/W	0d1	reg_pk_alp2_maxerr_mode :: 0 max err; 1: xerr . unsigned , default = 1
13: 8	R/W	0d13	reg_pk_alp2_core_rate :: normalized 64 as "1" . unsigned , default = 13
5: 0	R/W	0d1	reg_pk_alp2_core_ofst :: normalized 64 as "1" . signed , default = 1

Table 9-1500 SRSHARP0\_PK\_ALP2\_ERR2CURV\_TH\_RATE 0x3e1f

Bit(s)	R/W	Default	Description
31:24	R/W	0d0	reg_pk_alp2_minerr_par0 :: threshold0 of curve to map mierr to alp2 for luma channel, this will be set value of flat region mierr that no need peaking.. unsigned , default = 0
23:16	R/W	0d24	reg_pk_alp2_minerr_par1 :: threshold1 of curve to map mierr to alp2 for luma channel, this will be set value of texture region mierr that can not do peaking. 0~255.. unsigned , default = 24

Bit(s)	R/W	Default	Description
15: 8	R/W	0d0	reg_pk_alp2_minerr_par5 : : rate0 (for mierr<th0) of curve to map mierr to alp2 for luma channel. the larger of the value, the deep of the slope. 0~255.. unsigned , default = 0
7: 0	R/W	0d20	reg_pk_alp2_minerr_par6 : : rate1 (for mierr>th1) of curve to map mierr to alp2 for luma channel. the larger of the value, the deep of the slope. 0~255.. unsigned , default = 20

Table 9-1501 SRSHARP0\_PK\_ALP2\_ERR2CURV\_LIMIT 0x3e20

Bit(s)	R/W	Default	Description
31:24	R/W	0d0	reg_pk_alp2_minerr_par2 : : level limit(for mierr<th0) of curve to map mierr to alp2 for luma channel, this will be set to alp2 that we can do for flat region. 0~255.. unsigned , default = 0
23:16	R/W	0d16	reg_pk_alp2_minerr_par3 : : level limit(for th0<mierr<th1) of curve to map mierr to alp2 for luma channel, this will be set to alp2 that we can do for misc region. 0~255.. unsigned , default = 16
15: 8	R/W	0d63	reg_pk_alp2_minerr_par4 : : level limit(for mierr>th1) of curve to map mierr to alp2 for luma channel, this will be set to alp2 that we can do for texture region. 0~255. default = 63;. unsigned , default = 255

Table 9-1502 SRSHARP0\_PK\_ALP2\_MIN\_MAX 0x3e21

Bit(s)	R/W	Default	Description
13: 8	R/W	0d0	reg_pk_alp2_min : : normalized to 64 as '1'. unsigned , default = 0
5: 0	R/W	0d63	reg_pk_alp2_max : : normalized to 64 as '1'. unsigned , default = 63

Table 9-1503 SRSHARP0\_PK\_FINALGAIN\_HP\_BP 0x3e22

Bit(s)	R/W	Default	Description
17: 16	R/W	0d0	reg_final_gain_rs : : right shift bits for the gain normalization, 0 normal to 32 as 1; 1 normal to 64 as 1; -2 normal to 8 as 1; -1 normal to 16 as 1 . signed , default = 0
15: 8	R/W	0d40	reg_hp_final_gain : : gain to highpass boost result (including directional/circle blending), normalized 32 as '1', 0~255. 1.25 * 32. unsigned , default = 40
7: 0	R/W	0d30	reg_bp_final_gain : : gain to bandpass boost result (including directional/circle blending), normalized 32 as '1', 0~255. 1.25 * 32. unsigned , default = 30

Table 9-1504 SRSHARP0\_PK\_OS\_HORZ\_CORE\_GAIN 0x3e23

Bit(s)	R/W	Default	Description
31:24	R/W	0d8	reg_pk_os_hsidecore : : side coring (not to current pixel) to adaptive overshoot margin in horizontal direction. the larger of this value, the less overshoot admitted 0~255;. unsigned , default = 8
23:16	R/W	0d20	reg_pk_os_hsidegain : : side gain (not to current pixel) to adaptive overshoot margin in horizontal direction. normalized to 32 as '1'. 0~255;. unsigned , default = 20

Bit(s)	R/W	Default	Description
15: 8	R/W	0d2	reg_pk_os_hmidcore : : mid coring (to current pixel) to adaptive overshoot margin in horizontal direction. the larger of this value, the less overshoot admitted 0~255;. unsigned , default = 2
7: 0	R/W	0d20	reg_pk_os_hmidgain : : mid gain (to current pixel) to adaptive overshoot margin in horizontal direction. normalized to 32 as '1'. 0~255;. unsigned , default = 20

Table 9-1505 SRSHARP0\_PK\_OS\_VERT\_CORE\_GAIN 0x3e24

Bit(s)	R/W	Default	Description
31:24	R/W	0d8	reg_pk_os_vsidecore : : side coring (not to current pixel) to adaptive overshoot margin in vertical direction. the larger of this value, the less overshoot admitted 0~255;. unsigned , default = 8
23:16	R/W	0d20	reg_pk_os_vsidegain : : side gain (not to current pixel) to adaptive overshoot margin in vertical direction. normalized to 32 as '1'. 0~255;. unsigned , default = 20
15: 8	R/W	0d2	reg_pk_os_vmidcore : : mid coring (to current pixel) to adaptive overshoot margin in vertical direction. the larger of this value, the less overshoot admitted 0~255;. unsigned , default = 2
7: 0	R/W	0d20	reg_pk_os_vmidgain : : mid gain (to current pixel) to adaptive overshoot margin in vertical direction. normalized to 32 as '1'. 0~255;. unsigned , default = 20

Table 9-1506 SRSHARP0\_PK\_OS\_ADPT\_MISC 0x3e25

Bit(s)	R/W	Default	Description
31:24	R/W	0d40	reg_pk_os_minerr_core : : coring to minerr for adaptive overshoot margin. the larger of this value, the less overshoot admitted 0~255;. unsigned , default = 40
23:16	R/W	0d6	reg_pk_os_minerr_gain : : gain to minerr based adaptive overshoot margin. normalized to 64 as '1'. 0~255;. unsigned , default = 6
15: 8	R/W	0d200	reg_pk_os_adpt_max : : maximum limit adaptive overshoot margin (4x). 0~255; . unsigned , default = 200
7: 0	R/W	0d20	reg_pk_os_adpt_min : : minimum limit adaptive overshoot margin (1x). 0~255; . unsigned , default = 20

Table 9-1507 SRSHARP0\_PK\_OS\_STATIC 0x3e26

Bit(s)	R/W	Default	Description
29:28	R/W	0d2	reg_pk_osh_mode : : 0~3: (2x+1) window in H direction . unsigned , default = 2
25:24	R/W	0d2	reg_pk_osv_mode : : 0~3: (2x+1) window in V direction . unsigned , default = 2
21:12	R/W	0d200	reg_pk_os_down : : static negative overshoot margin. 0~1023; . unsigned , default = 200
9: 0	R/W	0d200	reg_pk_os_up : : static positive overshoot margin. 0~1023; . unsigned , default = 200

**Table 9-1508 SRSHARP0\_PK\_NR\_ENABLE 0x3e27**

Bit(s)	R/W	Default	Description
3: 2	R/W	0d0	reg_3d_mode : , 0: no 3D; 1: L/R; 2: T/B; 3: horizontal interleaved, dft = 0 // . unsigned , default = 0
1	R/W	0d1	reg_pk_en : . unsigned , default = 1
0	R/W	0d1	reg_nr_en : . unsigned , default = 1

**Table 9-1509 SRSHARP0\_PK\_DRT\_SAD\_MISC 0x3e28**

Bit(s)	R/W	Default	Description
31:24	R/W	0d24	reg_pk_sad_ver_gain : : gain to sad[4], 16 normalized to "1"; . unsigned , default = 24
23:16	R/W	0d24	reg_pk_sad_hor_gain : : gain to sad[0], 16 normalized to "1"; . unsigned , default = 24
10: 9	R/W	0d0	reg_pk_bias_diag : : bias towards diag . unsigned , default = 0
4: 0	R/W	0d24	reg_pk_drt_force : : force direction of drt peaking filter, h2b: 0:hp drt force, 1: bp drt force; 2: bp+hp drt force, 3: no force;. unsigned , default = 24

**Table 9-1510 SRSHARP0\_NR\_TI\_DNLP\_BLEND 0x3e29**

Bit(s)	R/W	Default	Description
10: 8	R/W	0d4	reg_dnlp_input_mode : : dnlp input options. 0: org_y; 1: gau_y; 2: gauadp_y; 3: edgadplpf_y; 4: nr_y;5: lti_y; 6: pk_y (before os);7: pk_y (after os). unsigned , default = 4
3: 2	R/W	0d1	reg_nr_cti_blend_mode : : blend mode of nr and lti result: 0: nr; 1:cti; 2: (nr+cti)/2; 3:cti + dlt_nr . unsigned , default = 1
1: 0	R/W	0d1	reg_nr_lti_blend_mode : : blend mode of nr and lti result: 0: nr; 1:lti; 2: (nr+lti)/2; 3:lti + dlt_nr . unsigned , default = 1

**Table 9-1511 SRSHARP0\_TI\_DIR\_CORE\_ALPHA 0x3e2a**

Bit(s)	R/W	Default	Description
29:24	R/W	0d10	reg_adp_lti_dir_alp_core_ofst : : ofst to min_err, alpha = (min_err - (max_err - min_err)*rate + ofst)/max_err*64; dft=10. unsigned , default = 10
19:16	R/W	0d0	reg_adp_lti_dir_alp_core_rate : : offset to min_err, alpha = (min_err - (max_err - min_err)*rate + ofst)/max_err*64; dft=0/32. unsigned , default = 0
13: 8	R/W	0d0	reg_adp_lti_dir_alpmin : : min value of alpha, alpha = (min_err+x +ofst)/max_err*64; dft=10 . unsigned , default = 0
5: 0	R/W	0d63	reg_adp_lti_dir_alpmax : : max value of alpha, alpha = (min_err+x +ofst)/max_err*64; dft=63 . unsigned , default = 63

Table 9-1512 SRSHARP0\_CTI\_DIR\_ALPHA 0x3e2b

Bit(s)	R/W	Default	Description
29:24	R/W	0d5	reg_adp_cti_dir_alp_core_ofst : : ofst to min_err, alpha = (min_err - (max_err - min_err)*rate + ofst)/max_err*64; dft=10. unsigned , default = 5
19:16	R/W	0d0	reg_adp_cti_dir_alp_core_rate : : ofset to min_err, alpha = (min_err - (max_err - min_err)*rate + ofst)/max_err*64; dft=0/32. unsigned , default = 0
13: 8	R/W	0d0	reg_adp_cti_dir_alpmin : : min value of alpha, alpha = (min_err +x+ofst)/max_err*64; dft=10 . unsigned , default = 0
5: 0	R/W	0d63	reg_adp_cti_dir_alpmax : : max value of alpha, alpha = (min_err +x+ofst)/max_err*64; dft=63 . unsigned , default = 63

Table 9-1513 SRSHARP0\_LTI\_CTI\_DF\_GAIN 0x3e2c

Bit(s)	R/W	Default	Description
29:24	R/W	0d16	reg_adp_lti_hdf_gain : : 8 normalized to "1"; default = 16 . unsigned , default = 16
21:16	R/W	0d12	reg_adp_lti_vdf_gain : : 8 normalized to "1"; default = 12 . unsigned , default = 12
13: 8	R/W	0d16	reg_adp_cti_hdf_gain : : 8 normalized to "1"; default = 16 . unsigned , default = 16
5: 0	R/W	0d12	reg_adp_cti_vdf_gain : : 8 normalized to "1"; default = 12 . unsigned , default = 12

Table 9-1514 SRSHARP0\_LTI\_CTI\_DIR\_AC\_DBG 0x3e2d

Bit(s)	R/W	Default	Description
30	R/W	0d1	reg_adp_lti_dir_lpf : : 0: no lpf; 1: [1 2 2 2 1]/8 lpf . unsigned , default = 1
28	R/W	0d0	reg_adp_lti_dir_difmode : : 0: y_dif; 1: y_dif + (u_dif+v_dif)/2; . unsigned , default = 0
26	R/W	0d1	reg_adp_cti_dir_lpf : : 0: no lpf; 1: [1 2 2 2 1]/8 lpf dft=1 . unsigned , default = 1
25:24	R/W	0d0	reg_adp_cti_dir_difmode : : 0: (u_dif+v_dif); 1: y_dif/2 + (u_dif+v_dif)*3/4; 2: y_dif + (u_dif+v_dif)/2; 3: y_dif*2 (not recomend). unsigned , default = 0
23:22	R/W	0d3	reg_adp_hvlti_dcblend_mode : : 0: hlti_dc; 1:vlti_dc; 2: avg 3; blend on alpha . unsigned , default = 3
21:20	R/W	0d3	reg_adp_hvcti_dcblend_mode : : 0: hcti_dc; 1:vcti_dc; 2: avg 3; blend on alpha . unsigned , default = 3
19:18	R/W	0d3	reg_adp_hvlti_acblend_mode : : hlti_ac; 1:vlti_ac; 2: add 3;;adaptive to alpha . unsigned , default = 3
17:16	R/W	0d3	reg_adp_hvcti_acblend_mode : : hcti_ac; 1:vcti_ac; 2: add 3;; adaptive to alpha . unsigned , default = 3
14:12	R/W	0d0	reg_adp_hlti_debug : , for hlti debug, default = 0 . unsigned , default = 0
10: 8	R/W	0d0	reg_adp_vlti_debug : , for vlti debug, default = 0 . unsigned , default = 0
6: 4	R/W	0d0	reg_adp_hcti_debug : , for hcti debug, default = 0 . unsigned , default = 0
2: 0	R/W	0d0	reg_adp_vcti_debug : , for vcti debug, default = 0 . unsigned , default = 0

Table 9-1515 SRSHARP0\_HCTI\_FLT\_CLP\_DC 0x3e2e

Bit(s)	R/W	Default	Description
28	R/W	0d1	reg_adp_hcti_en : , 0: no cti, 1: new cti, default = 1 . unsigned , default = 1
27:26	R/W	0d3	reg_adp_hcti_vdnflt : , 0: no lpf, 1:[0,2,4,2,0], 2 : [1 2 2 2 1]/8 3:[1 0 2 0 1]/4, default = 3 . unsigned , default = 3
25:24	R/W	0d2	reg_adp_hcti_hdnflt : , 0: no lpf, 1:[0, 0, 0, 4, 8, 4, 0, 0, 0], 2:[0, 0, 2, 4, 4, 4, 2, 0, 0], 3: [1, 2, 2, 2, 2, 2, 2, 1], default = 2. unsigned , default = 2
23:22	R/W	0d3	reg_adp_hcti_ddnflt : , 0: no lpf, 1:[0,2,4,2,0], 2 : [1 2 2 2 1]/8 3:[1 0 2 0 1]/4, default = 3 . unsigned , default = 3
21:20	R/W	0d2	reg_adp_hcti_lpf0flt : , 0:no filter; 1:sigma=0.75, 2: sigma = 1.0, 3: sigma = 1.5, default = 2 . unsigned , default = 2
19:18	R/W	0d2	reg_adp_hcti_lpf1flt : , 0:no filter; 1:sigma= 2.0, 2: sigma = 3.0, 3: sigma = 4.0, default = 2 . unsigned , default = 2
17:16	R/W	0d2	reg_adp_hcti_lpf2flt : , 0:no filter; 1:sigma=5.0, 2: sigma = 9.0, 3: sigma = 13.0, default = 2 . unsigned , default = 2
15:12	R/W	0d7	reg_adp_hcti_hard_clp_win : , window size, 0~8, default = 7 . unsigned , default = 7
11: 8	R/W	0d3	reg_adp_hcti_hard_win_min : , window size, 0~8, default = 3 . unsigned , default = 3
4	R/W	0d1	reg_adp_hcti_clp_mode : , 0: hard clip, 1: adaptive clip, default = 1 . unsigned , default = 1
2: 0	R/W	0d0	reg_adp_hcti_dc_mode : , 0:dn, 1:lpf0, 2:lpf1, 3:lpf2, 4: lpf3: 5: vdn result; 6/7: org, default = 0 . unsigned , default = 0

Table 9-1516 SRSHARP0\_HCTI\_BST\_GAIN 0x3e2f

Bit(s)	R/W	Default	Description
31:24	R/W	0d80	reg_adp_hcti_bst_gain0 : : gain of the bandpass 0 (lpf1-lpf2)- LBP, default = 80. unsigned , default = 80
23:16	R/W	0d96	reg_adp_hcti_bst_gain1 : : gain of the bandpass 1 (lpf0-lpf1)- BP, default = 96. unsigned , default = 96
15: 8	R/W	0d64	reg_adp_hcti_bst_gain2 : : gain of the bandpass 2 (hdn-lpf0)- HP, default = 64. unsigned , default = 64
7: 0	R/W	0d16	reg_adp_hcti_bst_gain3 : : gain of the unsharp band (yubin-hdn) - US, default = 16. unsigned , default = 16

Table 9-1517 SRSHARP0\_HCTI\_BST\_CORE 0x3e30

Bit(s)	R/W	Default	Description
31:24	R/W	0d0	reg_adp_hcti_bst_core0 : : core of the bandpass 0 (lpf1-lpf2)- LBP, default = 0 . unsigned , default = 0
23:16	R/W	0d0	reg_adp_hcti_bst_core1 : : core of the bandpass 1 (lpf0-lpf1)- BP, default = 0 . unsigned , default = 0
15: 8	R/W	0d0	reg_adp_hcti_bst_core2 : : core of the bandpass 2 (hdn-lpf0)- HP, default = 0 . unsigned , default = 0
7: 0	R/W	0d0	reg_adp_hcti_bst_core3 : : core of the unsharp band (yubin-hdn) - US, default = 0. unsigned , default = 0



**Table 9-1518 SRSHARP0\_HCTI\_CON\_2\_GAIN\_0 0x3e31**

Bit(s)	R/W	Default	Description
31:29	R/W	0d2	reg_adp_hcti_con_mode : : con mode 0:[0, 0,-1, 1, 0, 0, 0]+[0, 0, 0, 1,-1, 0, 0], 1:[0, 0,-1, 0, 1, 0, 0], 2:[0,-1, 0, 0, 0, 1, 0], 3:[-1, 0, 0, 0, 0, 0, 1], 4: ..... default = 2. unsigned , default = 2
28:26	R/W	0d3	reg_adp_hcti_dx_mode : : dx mode 0: [-1 1 0]; 1~7: [-1 (2x+1)"0" 1], default = 3. unsigned , default = 3
25:24	R/W	0d1	reg_adp_hcti_con_lpf : : lpf mode of the con: 0: [1 2 1]/4; 1:[1 2 2 1]/8, default = 1. unsigned , default = 1
23:16	R/W	0d25	reg_adp_hcti_con_2_gain0 : , default = 25. unsigned , default = 25
15: 8	R/W	0d60	reg_adp_hcti_con_2_gain1 : , default = 60. unsigned , default = 60
7: 0	R/W	0d0	reg_adp_hcti_con_2_gain2 : 0;, default = 0. unsigned , default = 0

**Table 9-1519 SRSHARP0\_HCTI\_CON\_2\_GAIN\_1 0x3e32**

Bit(s)	R/W	Default	Description
31:24	R/W	0d96	reg_adp_hcti_con_2_gain3 : 96;, default = 96. unsigned , default = 96
23:16	R/W	0d5	reg_adp_hcti_con_2_gain4 : 5;, default = 5. unsigned , default = 5
15: 8	R/W	0d80	reg_adp_hcti_con_2_gain5 : 80;, default = 80. unsigned , default = 80
7: 0	R/W	0d20	reg_adp_hcti_con_2_gain6 : 20;, default = 20. unsigned , default = 20

**Table 9-1520 SRSHARP0\_HCTI\_OS\_MARGIN 0x3e33**

Bit(s)	R/W	Default	Description
7: 0	R/W	0d0	reg_adp_hcti_os_margin : : margin for hcti overshoot, default = 0. unsigned , default = 0

**Table 9-1521 SRSHARP0\_HLTI\_FLT\_CLP\_DC 0x3e34**

Bit(s)	R/W	Default	Description
28	R/W	0d1	reg_adp_hlti_en : , 0: no cti, 1: new cti, default = 1. unsigned , default = 1
27:26	R/W	0d2	reg_adp_hlti_vdn_fit : , 0: no lpf; 1:[0,2,4,2,0], 2 : [1 2 2 2 1]/8 3:[1 0 2 0 1]/4, default = 2. unsigned , default = 2
25:24	R/W	0d2	reg_adp_hlti_hdn_fit : , 0: no lpf; 1:[0, 0, 0, 4, 8, 4, 0, 0, 0], 2:[0, 0, 2, 4, 4, 4, 2, 0, 0], 3: [1, 2, 2, 2, 2, 2, 2, 2, 1], default = 2. unsigned , default = 2
23:22	R/W	0d2	reg_adp_hlti_ddn_fit : , 0: no lpf; 1:[0,2,4,2,0], 2 : [1 2 2 2 1]/8 3:[1 0 2 0 1]/4, default = 2. unsigned , default = 2
21:20	R/W	0d2	reg_adp_hlti_lpf0_fit : , 0:no filter; 1:sigma=0.75, 2: sigma = 1.0, 3: sigma = 1.5, default = 2. unsigned , default = 2
19:18	R/W	0d2	reg_adp_hlti_lpf1_fit : , 0:no filter; 1:sigma= 2.0, 2: sigma = 3.0, 3: sigma = 4.0, default = 2. unsigned , default = 2
17:16	R/W	0d2	reg_adp_hlti_lpf2_fit : , 0:no filter; 1:sigma=5.0, 2: sigma = 9.0, 3: sigma = 13.0, default = 2. unsigned , default = 2

Bit(s)	R/W	Default	Description
15:12	R/W	0d2	reg_adp_hlti_hard_clp_win : , window size, 0~8, default = 2 . unsigned , default = 2
11: 8	R/W	0d1	reg_adp_hlti_hard_win_min : , window size, 0~8, default = 1 . unsigned , default = 1
4	R/W	0d0	reg_adp_hlti_clp_mode : , 0: hard clip, 1: adaptive clip, default = 0 . unsigned , default = 0
2: 0	R/W	0d4	reg_adp_hlti_dc_mode : , 0:dn, 1:lpf0, 2:lpf1, 3:lpf2, 4: lpf3: 5: vdn result; 6/7:org, default = 4 . unsigned , default = 4

Table 9-1522 SRSHARP0\_HLTI\_BST\_GAIN 0x3e35

Bit(s)	R/W	Default	Description
31:24	R/W	0d40	reg_adp_hlti_bst_gain0 : : gain of the bandpass 0 (lpf1-lpf2)- LBP, default = 40 . unsigned , default = 40
23:16	R/W	0d48	reg_adp_hlti_bst_gain1 : : gain of the bandpass 1 (lpf0-lpf1)- BP, default = 48 . unsigned , default = 48
15: 8	R/W	0d32	reg_adp_hlti_bst_gain2 : : gain of the bandpass 2 (hdn-lpf0)- HP, default = 32 . unsigned , default = 32
7: 0	R/W	0d16	reg_adp_hlti_bst_gain3 : : gain of the unsharp band (yuvin-hdn) - US, default = 16 . unsigned , default = 16

Table 9-1523 SRSHARP0\_HLTI\_BST\_CORE 0x3e36

Bit(s)	R/W	Default	Description
31:24	R/W	0d5	reg_adp_hlti_bst_core0 : : core of the bandpass 0 (lpf1-lpf2)- LBP, default = 5 . unsigned , default = 5
23:16	R/W	0d5	reg_adp_hlti_bst_core1 : : core of the bandpass 1 (lpf0-lpf1)- BP, default = 5 . unsigned , default = 5
15: 8	R/W	0d5	reg_adp_hlti_bst_core2 : : core of the bandpass 2 (hdn-lpf0)- HP, default = 5 . unsigned , default = 5
7: 0	R/W	0d3	reg_adp_hlti_bst_core3 : : core of the unsharp band (yuvin-hdn) - US, default = 3 . unsigned , default = 3

Table 9-1524 SRSHARP0\_HLTI\_CON\_2\_GAIN\_0 0x3e37

Bit(s)	R/W	Default	Description
31:29	R/W	0d2	reg_adp_hlti_con_mode : : con mode 0:[0, 0,-1, 1, 0, 0, 0]+[0, 0, 0, 1,-1, 0, 0], 1: [0, 0,-1, 0, 1, 0, 0], 2: [0,-1, 0, 0, 0, 1, 0], 3:[-1, 0, 0, 0, 0, 0, 1], 4: ....., default = 2 . unsigned , default = 2
28:26	R/W	0d3	reg_adp_hlti_dx_mode : : dx mode 0: [-1 1 0]; 1~7: [-1 (2x+1)"0" 1], default = 3 . unsigned , default = 3
25:24	R/W	0d1	reg_adp_hlti_con_lpf : : lpf mode of the con: 0: [1 2 1]/4; 1:[1 2 2 1]/8, default = 1 . unsigned , default = 1
23:16	R/W	0d25	reg_adp_hlti_con_2_gain0 : 25;, default = 25 . unsigned , default = 25
15: 8	R/W	0d60	reg_adp_hlti_con_2_gain1 : 60;, default = 60 . unsigned , default = 60
7: 0	R/W	0d90	reg_adp_hlti_con_2_gain2 : 0;, default = 90 . unsigned , default = 90

**Table 9-1525 SRSHARP0\_HLTI\_CON\_2\_GAIN\_1 0x3e38**

Bit(s)	R/W	Default	Description
31:24	R/W	0d96	reg_adp_hlti_con_2_gain3 : 96;, default = 96 . unsigned , default = 96
23:16	R/W	0d95	reg_adp_hlti_con_2_gain4 : 5;, default = 95 . unsigned , default = 95
15: 8	R/W	0d80	reg_adp_hlti_con_2_gain5 : 80;, default = 80 . unsigned , default = 80
7: 0	R/W	0d20	reg_adp_hlti_con_2_gain6 : 20;, default = 20 . unsigned , default = 20

**Table 9-1526 SRSHARP0\_HLTI\_OS\_MARGIN 0x3e39**

Bit(s)	R/W	Default	Description
7: 0	R/W	0d0	reg_adp_hlti_os_margin : : margin for hlti overshoot, default = 0 . unsigned , default = 0

**Table 9-1527 SRSHARP0\_VLTI\_FLT\_CON\_CLP 0x3e3a**

Bit(s)	R/W	Default	Description
14	R/W	0d1	reg_adp_vlti_en : : enable bit of vlti, default = 1 . unsigned , default = 1
13:12	R/W	0d3	reg_adp_vlti_hxn_fit : : 0: no dn; 1: [1 2 1]/4; 2 : [1 2 2 2 1]/8 3:[1 0 2 0 1]/4, default = 3 . unsigned , default = 3
11:10	R/W	0d3	reg_adp_vlti_dxn_fit : : 0: no dn; 1: [1 2 1]/4; 2 : [1 2 2 2 1]/8 3:[1 0 2 0 1]/4, default = 3 . unsigned , default = 3
9: 8	R/W	0d3	reg_adp_vlti_han_fit : : 0: no dn; 1: [1 2 1]/4; 2 : [1 2 2 2 1]/8 3:[1 0 2 0 1]/4, default = 3 . unsigned , default = 3
7: 6	R/W	0d3	reg_adp_vlti_dan_fit : : 0: no dn; 1: [1 2 1]/4; 2 : [1 2 2 2 1]/8 3:[1 0 2 0 1]/4, default = 3 . unsigned , default = 3
5: 4	R/W	0d2	reg_adp_vlti_dx_mode : : 0:[-1 1] 1:[-1 0 -1]; 2/3: [-1 0 0 0 -1], default = 2 . unsigned , default = 2
2	R/W	0d1	reg_adp_vlti_con_lpf : : lpf mode of the con: 0: [1 2 1]/4; 1:[1 2 2 2 1]/8, default = 1 . unsigned , default = 1
0	R/W	0d1	reg_adp_vlti_hard_clp_win : : window size; 0: 1x3 window; 1: 1x5 window, default = 1 . unsigned , default = 1

**Table 9-1528 SRSHARP0\_VLTI\_BST\_GAIN 0x3e3b**

Bit(s)	R/W	Default	Description
23:16	R/W	0d32	reg_adp_vlti_bst_gain0 : : gain to boost filter [-1 2 -1];, default = 32. unsigned , default = 32
15: 8	R/W	0d32	reg_adp_vlti_bst_gain1 : : gain to boost filter [-1 0 2 0 -1];, default = 32 . unsigned , default = 32
7: 0	R/W	0d32	reg_adp_vlti_bst_gain2 : : gain to boost filter usf, default = 32 . unsigned , default = 32

**Table 9-1529 SRSHARP0\_VLTI\_BST\_CORE 0x3e3c**

Bit(s)	R/W	Default	Description
23:16	R/W	0d5	reg_adp_vlti_bst_core0 : : coring to boost filter [-1 2 -1];, default = 5 . unsigned , default = 5
15: 8	R/W	0d5	reg_adp_vlti_bst_core1 : : coring to boost filter [-1 0 2 0 -1];, default = 5 . unsigned , default = 5
7: 0	R/W	0d3	reg_adp_vlti_bst_core2 : : coring to boost filter usf, default = 3 . unsigned , default = 3

**Table 9-1530 SRSHARP0\_VLTI\_CON\_2\_GAIN\_0 0x3e3d**

Bit(s)	R/W	Default	Description
31:24	R/W	0d25	reg_adp_vlti_con_2_gain0 : 25;, default = 25 . unsigned , default = 25
23:16	R/W	0d69	reg_adp_vlti_con_2_gain1 : 60;, default = 69 . unsigned , default = 60
15: 8	R/W	0d90	reg_adp_vlti_con_2_gain2 : 0;, default = 90 . unsigned , default = 90
7: 0	R/W	0d96	reg_adp_vlti_con_2_gain3 : 96;, default = 96 . unsigned , default = 96

**Table 9-1531 SRSHARP0\_VLTI\_CON\_2\_GAIN\_1 0x3e3e**

Bit(s)	R/W	Default	Description
31:24	R/W	0d95	reg_adp_vlti_con_2_gain4 : 5;, default = 95 . unsigned , default = 95
23:16	R/W	0d80	reg_adp_vlti_con_2_gain5 : 80;, default = 80 . unsigned , default = 80
15: 8	R/W	0d20	reg_adp_vlti_con_2_gain6 : 20;, default = 20 . unsigned , default = 20
7: 0	R/W	0d0	reg_adp_vlti_os_margin : : margin for vlti overshoot, default = 0 . unsigned , default = 0

**Table 9-1532 SRSHARP0\_VCTI\_FLT\_CON\_CLP 0x3e3f**

Bit(s)	R/W	Default	Description
14	R/W	0d1	reg_adp_vcti_en : : enable bit of vlti, default = 1 . unsigned , default = 1
13:12	R/W	0d3	reg_adp_vcti_hxn_ft : : 0: no dn; 1: [1 2 1]/4; 2: [1 2 2 2 1]/8 3:[1 0 2 0 1]/4, default = 3 . unsigned , default = 3
11:10	R/W	0d3	reg_adp_vcti_dxn_ft : : 0: no dn; 1: [1 2 1]/4; 2: [1 2 2 2 1]/8 3:[1 0 2 0 1]/4, default = 3 . unsigned , default = 3
9: 8	R/W	0d3	reg_adp_vcti_han_ft : : 0: no dn; 1: [1 2 1]/4; 2: [1 2 2 2 1]/8 3:[1 0 2 0 1]/4, default = 3 . unsigned , default = 3
7: 6	R/W	0d3	reg_adp_vcti_dan_ft : : 0: no dn; 1: [1 2 1]/4; 2: [1 2 2 2 1]/8 3:[1 0 2 0 1]/4, default = 3 . unsigned , default = 3
5: 4	R/W	0d2	reg_adp_vcti_dx_mode : : 0:[-1 1] 1:[-1 0 -1]; 2/3: [-1 0 0 0 -1], default = 2 . unsigned , default = 2
2	R/W	0d1	reg_adp_vcti_con_lpf : : lpf mode of the con: 0: [1 2 1]/4; 1:[1 2 2 2 1]/8, default = 1 . unsigned , default = 1
0	R/W	0d1	reg_adp_vcti_hard_clp_win : : window size; 0: 1x3 window; 1: 1x5 window, default = 1. unsigned , default = 1

**Table 9-1533 SRSHARP0\_VCTI\_BST\_GAIN 0x3e40**

Bit(s)	R/W	Default	Description
23:16	R/W	0d0	reg_adp_vcti_bst_gain0 : : gain to boost filter [-1 2 -1];, default = 0 . unsigned , default = 0
15: 8	R/W	0d0	reg_adp_vcti_bst_gain1 : : gain to boost filter [-1 0 2 0 -1];, default = 0 . unsigned , default = 0
7: 0	R/W	0d0	reg_adp_vcti_bst_gain2 : : gain to boost filter usf, default = 0 . unsigned , default = 0

**Table 9-1534 SRSHARP0\_VCTI\_BST\_CORE 0x3e41**

Bit(s)	R/W	Default	Description
23:16	R/W	0d0	reg_adp_vcti_bst_core0 : : coring to boost filter [-1 2 -1];, default = 0 . unsigned , default = 0
15: 8	R/W	0d0	reg_adp_vcti_bst_core1 : : coring to boost filter [-1 0 2 0 -1];, default = 0 . unsigned , default = 0
7: 0	R/W	0d0	reg_adp_vcti_bst_core2 : : coring to boost filter usf, default = 0 . unsigned , default = 0

**Table 9-1535 SRSHARP0\_VCTI\_CON\_2\_GAIN\_0 0x3e42**

Bit(s)	R/W	Default	Description
31:24	R/W	0d25	reg_adp_vcti_con_2_gain0 : 25;,, default = 25 . unsigned , default = 25
23:16	R/W	0d60	reg_adp_vcti_con_2_gain1 : 60;,, default = 60 . unsigned , default = 60
15: 8	R/W	0d90	reg_adp_vcti_con_2_gain2 : 0;,, default = 90 . unsigned , default = 90
7: 0	R/W	0d96	reg_adp_vcti_con_2_gain3 : 96;,, default = 96 . unsigned , default = 96

**Table 9-1536 SRSHARP0\_VCTI\_CON\_2\_GAIN\_1 0x3e43**

Bit(s)	R/W	Default	Description
31:24	R/W	0d95	reg_adp_vcti_con_2_gain4 : 5;,, default = 95 . unsigned , default = 95
23:16	R/W	0d80	reg_adp_vcti_con_2_gain5 : 80;,, default = 80 . unsigned , default = 80
15: 8	R/W	0d20	reg_adp_vcti_con_2_gain6 : 20;,, default = 20 . unsigned , default = 20
7: 0	R/W	0d0	reg_adp_vcti_os_margin : : margin for vcti overshoot, default = 0 . unsigned , default = 0

**Table 9-1537 SRSHARP0\_SHARP\_3DLIMIT 0x3e44**

Bit(s)	R/W	Default	Description
28:16	R/W	0d0	reg_3d_mid_width : ,width of left part of 3d input, dft = half size of input width default = 0 . unsigned , default = 960
12: 0	R/W	0d0	reg_3d_mid_height : ,height of left part of 3d input, dft = half size of input height default = 0 . unsigned , default = 540

Table 9-1538 SRSHARP0\_DNLP\_EN 0x3e45

Bit(s)	R/W	Default	Description
15:8	R/W	0d0	reg_dnlp_hblank: . unsigned , default = 8
0	R/W	0d1	reg_dnlp_en : . unsigned , default = 1

Table 9-1539 SRSHARP0\_DEMO\_CTRL 0x3e56

Bit(s)	R/W	Default	Description
18:17	R/W	0d2	demo_disp_position : . unsigned , default = 2
16	R/W	0d0	demo_hsvsharp_enable : . unsigned , default = 0
12: 0	R/W	0d360	demo_left_top_screen_width : . . unsigned , default = 360

Table 9-1540 SRSHARP0\_SHARP\_SR2\_CTRL 0x3e57

Bit(s)	R/W	Default	Description
24	R/W	0	reg_sr2_bic_pknr_bypass : bypass peaking/TI/Cubic
23:22	R/W		reserved
21:16	R/W	24	sr2_pk_la_err_dis_rate, low angle and high angle error should not be no less than nearby_error* rate/64
15: 8	R/W	16	sr2_pk_sad_diag_gain, gain to sad[2] and sad[6], 16 normalized to 1
7	R/W	0	sr2_vert_outphs, vertical output pixel phase, 0: 0 phase; 1: 1/2 phase
6	R/W	0	sr2_horz_outphs, horizontal output pixel phase, 0: 0 phase; 1: 1/2 phase
5	R/W	0	sr2_vert_ratio , vertical scale ratio, 0-> 1:1; 1-> 1:2
4	R/W	0	sr2_horz_ratio , horizontal scale ratio, 0-> 1:1; 1-> 1:2
3	R/W	1	sr2_bic_norm , normalization of bicubical: 0: 128; 1: 64
2	R/W	0	sr2_enable , 1 to enable super scaler
1	R/W	0	sr2_sharp_prc_lr_hbic,
0	R/W	0	sr2_sharp_prc_lr, 1: LTI/CTI/NR/Peaking processing using LR grid. 0: on HR grid; 1:on LR grid, horizontally no upscale, but using simple bic.

Table 9-1541 SRSHARP0\_SHARP\_SR2\_YBIC\_HCOEF0 0x3e58

Bit(s)	R/W	Default	Description
31:24	R/W	0	sr2_y_bic_hcoeff03, signed
23:16	R/W	0	sr2_y_bic_hcoeff02, signed
15: 8	R/W	64	sr2_y_bic_hcoeff01, signed
7: 0	R/W	0	sr2_y_bic_hcoeff00, signed

**Table 9-1542 SRSHARP0\_SHARP\_SR2\_YBIC\_HCOEF1 0x3e59**

Bit(s)	R/W	Default	Description
31:24	R/W	-4	sr2_y_bic_hcoeff13 , signed
23:16	R/W	36	sr2_y_bic_hcoeff12 , signed
15: 8	R/W	36	sr2_y_bic_hcoeff11 , signed
7: 0	R/W	-4	sr2_y_bic_hcoeff10 , signed

**Table 9-1543 SRSHARP0\_SHARP\_SR2\_CBIC\_HCOEF0 0x3e5a**

Bit(s)	R/W	Default	Description
31:24	R/W	0	sr2_c_bic_hcoeff03 , signed
23:16	R/W	21	sr2_c_bic_hcoeff02 , signed
15: 8	R/W	22	sr2_c_bic_hcoeff01 , signed
7: 0	R/W	21	sr2_c_bic_hcoeff00 , signed

**Table 9-1544 SRSHARP0\_SHARP\_SR2\_CBIC\_HCOEF1 0x3e5b**

Bit(s)	R/W	Default	Description
31:24	R/W	-4	sr2_c_bic_hcoeff13 , signed
23:16	R/W	36	sr2_c_bic_hcoeff12 , signed
15: 8	R/W	36	sr2_c_bic_hcoeff11 , signed
7: 0	R/W	-4	sr2_c_bic_hcoeff10 , signed

**Table 9-1545 SHARP\_SR2\_YBIC\_VCOEF0 0x3e5c**

Bit(s)	R/W	Default	Description
31:24	R/W	0	sr2_y_bic_vcoeff03 , signed
23:16	R/W	0	sr2_y_bic_vcoeff02 , signed
15: 8	R/W	64	sr2_y_bic_vcoeff01 , signed
7: 0	R/W	0	sr2_y_bic_vcoeff00 , signed

**Table 9-1546 SRSHARP0\_SHARP\_SR2\_YBIC\_VCOEF1 0x3e5d**

Bit(s)	R/W	Default	Description
31:24	R/W	-4	sr2_y_bic_vcoeff13 , signed
23:16	R/W	36	sr2_y_bic_vcoeff12 , signed
15: 8	R/W	36	sr2_y_bic_vcoeff11 , signed
7: 0	R/W	-4	sr2_y_bic_vcoeff10 , signed

Table 9-1547 SRSHARP0\_SHARP\_SR2\_CBIC\_VCOEF0 0x3e5e

Bit(s)	R/W	Default	Description
31:24	R/W	0	sr2_c_bic_vcoeff03 , signed
23:16	R/W	21	sr2_c_bic_vcoeff02 , signed
15: 8	R/W	22	sr2_c_bic_vcoeff01 , signed
7: 0	R/W	21	sr2_c_bic_vcoeff00 , signed

Table 9-1548 SRSHARP0\_SHARP\_SR2\_CBIC\_VCOEF1 0x3e5f

Bit(s)	R/W	Default	Description
31:24	R/W	-4	sr2_c_bic_vcoeff13 , signed
23:16	R/W	36	sr2_c_bic_vcoeff12 , signed
15: 8	R/W	36	sr2_c_bic_vcoeff11 , signed
7: 0	R/W	-4	sr2_c_bic_vcoeff10 , signed

Table 9-1549 SRSHARP0\_SHARP\_SR2\_MISC 0x3e60

Bit(s)	R/W	Default	Description
31:2	R/W		reserved
1	R/W	0	sr2_cmpmux_bef , 0 : no swap for YUV/RGB; 1: swap for YUV/RGB, YUV/RGB->UVY/GBR
0	R/W	0	sr2_cmpmux_aft , 0 : no swap for YUV/RGB; 1: swap for YUV/RGB, UVY/GBR->YUV/RGB

Table 9-1550 SRSHARP0\_SR3\_SAD\_CTRL 0x3e61

Bit(s)	R/W	Default	Description
31:30	R/W		reserved
29:24	R/W	0d6	reg_sr3_pk_sad_core_rate : rate of coring.
23:22	R/W		reserved
21:16	R/W	0d6	reg_sr3_lti_sad_core_rate : rate of coring.
15:14	R/W		reserved
13:8	R/W	0d6	reg_sr3_cti_sad_core_rate : rate of coring.
7	R/W	0d1	reg_sr3_lti_hsad_mode: mode for hsad of lti calculation, 0:block based; 1: other sharp
6	R/W	0d1	reg_sr3_cti_hsad_mode: mode for hsad of cti calculation, 0:block based; 1: other sharp
5	R/W	0d1	reg_sr3_lti_dsad_mode: mode for dsad of lti calculation, 0:block based; 1: other sharp
4	R/W	0d1	reg_sr3_cti_dsad_mode: mode for dsad of cti calculation, 0:block based; 1: other sharp
3	R/W	0d1	reg_sr3_lti_vsad_mode: mode for vsad of lti calculation, 0:block based; 1: other sharp



Bit(s)	R/W	Default	Description
2	R/W	0d1	reg_sr3_cti_vsad_mode: mode for vsad of cti calculation, 0:block based; 1: other sharp
1	R/W	0d1	reg_sr3_lti_hsad_hlpf: hlpf for hsad of lti calculation, 0:no hlpf; 1: with [1 2 1] hlpf.
0	R/W	0d1	reg_sr3_cti_hsad_hlpf: hlpf for hsad of cti calculation, 0:no hlpf; 1: with [1 2 1] hlpf.

Table 9-1551 SRSHARP0\_SR3\_PK\_CTRL0 0x3e62

Bit(s)	R/W	Default	Description
31:12	R/W		reserved
11	R/W	0d1	reg_sr3_pk_sad_mode: mode for sad of peaking calculation, 0: block based; 1: other sharp.
10	R/W	0d1	reg_sr3_pk_hsad_hlpf: hlpf for hsad for peaking calculation,0:no hlpf; 1: with [1 2 2 2 1] hlpf.
9	R/W	0d1	reg_sr3_pk_vsad_hlpf: hlpf for vsad for peaking calculation,0:no hlpf; 1: with [1 2 2 2 1] hlpf.
8	R/W	0d1	reg_sr3_pk_dsad_hlpf: hlpf for dsad for peaking calculation,0:no hlpf; 1: with [1 2 2 2 1] hlpf.
7:6	R/W	0d3	reg_sr3_pk_hpdrtr_mode: mode for HPdrtr filter
5:4	R/W	0d3	reg_sr3_pk_bpdrtr_mode: mode for BPdrtr filter
3:2	R/W	0d3	reg_pk_drtrbld_range: range of the min2 and min direction distance
1	R/W		reserved
0	R/W	0d0	reg_sr3_pk_ti_blend_mode: blend mode of the TI and PK result

Table 9-1552 SRSHARP0\_SR3\_PK\_CTRL1 0x3e63

Bit(s)	R/W	Default	Description
31	R/W		reserved
30:28	R/W	0d1	reg_sr3_pk_Hp_hvcon_replace8_maxsad: replace HP hvcon by maxsad
26:24	R/W	0d1	reg_sr3_pk_bp_hvcon_replace8_maxsad: replace BP hvcon by maxsad
23:16	R/W	0d32	reg_sr3_pk_hp_hvcon_replace8lv_gain: gain to local variant before calculating the hv gain for peaking.
15:8	R/W	8	reg_sr3_dejaggy_hblank
7	R/W	0d1	reg_sr3_sad_intlev_mode: interleave detect xerr mode: 0 max; 1: sum
6	R/W	0d1	reg_sr3_sad_intlev_mode1: mode 1 of using diagonal protection: 1: with diagonal protection
5:0	R/W	0d12	reg_sr3_sad_intlev_gain: interleave detection for sad gain applied, normalized to 8 as 1

**Table 9-1553 SRSHARP0\_DEJ\_CTRL 0x3e64**

Bit(s)	R/W	Default	Description
15:8	R/W	8	reg_sr3_dejaggy_hblank
7:4	R/W		reserved
3:2	R/W	0d3	reg_sr3_dejaggy_sameside_prct: enable of sr3 dejaggy same side curve protect from filter, [0] for proc path; [1] for ctrl path.
1	R/W	0d1	reg_sr3_dejaggy_sameside_mode: mode of sameside flag decision
0	R/W	0d1	reg_sr3_dejaggy_enable: enable of sr3 dejaggy

**Table 9-1554 SRSHARP0\_DEJ\_ALPHA 0x3e65**

Bit(s)	R/W	Default	Description
31:28	R/W	0d0	reg_sr3_dejaggy_ctrchrom_alpha_1 : alpha for LR video LPF
27:24	R/W	0d15	reg_sr3_dejaggy_ctrchrom_alpha_0 : alpha for LR video LPF
23:20	R/W	0d0	reg_sr3_dejaggy_ctrluma_alpha_1 : alpha for LR video LPF
19:16	R/W	0d15	reg_sr3_dejaggy_ctrluma_alpha_0 : alpha for LR video LPF
15:12	R/W	0d4	reg_sr3_dejaggy_procchrom_alpha_1: alpha for LR video LPF
11:8	R/W	0d6	reg_sr3_dejaggy_procchrom_alpha_0: alpha for LR video LPF
7:4	R/W	0d4	reg_sr3_dejaggy_procluma_alpha_1: alpha for LR video LPF
3:0	R/W	0d6	reg_sr3_dejaggy_procluma_alpha_0: alpha for LR video LPF

**Table 9-1555 SRSHARP0\_SR3\_DRTLPF\_EN 0x3e66**

Bit(s)	R/W	Default	Description
31:15	R/W		reserved
14:8	R/W	0d0	reg_pk_debug_edge
6:4	R/W	0d0	reg_sr3_drtlpf_theta_en
2:0	R/W	0d7	reg_sr3_drtlpf_enable: directional lpf on Y/U/V channels

**Table 9-1556 SRSHARP0\_SR3\_DRTLPF\_ALPHA\_0 0x3e67**

Bit(s)	R/W	Default	Description
31:30	R/W		reserved
29:24	R/W	0d9	reg_sr3_drtlpf_alpha_3
23:22	R/W		reserved
21:16	R/W	0d10	reg_sr3_drtlpf_alpha_2
15:14	R/W		reserved
13:8	R/W	0d11	reg_sr3_drtlpf_alpha_1
7:6	R/W		reserved
5:0	R/W	0d12	reg_sr3_drtlpf_alpha_0: directional lpf alpha coef for min_sad/max_sad compare

**Table 9-1557 SRSHARP0\_SR3\_DRTLPF\_ALPHA\_1 0x3e68**

Bit(s)	R/W	Default	Description
31:30	R/W		reserved
29:24	R/W	0d1	reg_sr3_drtlpf_alpha_7
23:22	R/W		reserved
21:16	R/W	0d4	reg_sr3_drtlpf_alpha_6
15:14	R/W		reserved
13:8	R/W	0d7	reg_sr3_drtlpf_alpha_5
7:6	R/W		reserved
5:0	R/W	0d8	reg_sr3_drtlpf_alpha_4: directional lpf alpha coef for min_sad/max_sad compare

**Table 9-1558 SRSHARP0\_SR3\_DRTLPF\_ALPHA\_2 0x3e69**

Bit(s)	R/W	Default	Description
31:30	R/W		reserved
29:24	R/W	0d0	reg_sr3_drtlpf_alpha_11
23:22	R/W		reserved
21:16	R/W	0d0	reg_sr3_drtlpf_alpha_10
15:14	R/W		reserved
13:8	R/W	0d0	reg_sr3_drtlpf_alpha_9
7:6	R/W		reserved
5:0	R/W	0d0	reg_sr3_drtlpf_alpha_8: directional lpf alpha coef for min_sad/max_sad compare

**Table 9-1559 SRSHARP0\_SR3\_DRTLPF\_ALPHA\_OFST 0x3e6a**

Bit(s)	R/W	Default	Description
31:28	R/W	0	reg_sr3_drtlpf_alpha_ofst7
27:24	R/W	0	reg_sr3_drtlpf_alpha_ofst6
23:20	R/W	0	reg_sr3_drtlpf_alpha_ofst5
19:16	R/W	-2	reg_sr3_drtlpf_alpha_ofst4
15:12	R/W	0	reg_sr3_drtlpf_alpha_ofst3
11:8	R/W	0	reg_sr3_drtlpf_alpha_ofst2
7:4	R/W	0	reg_sr3_drtlpf_alpha_ofst1
3:0	R/W	-2	reg_sr3_drtlpf_alpha_ofst0: directional lpf alpha coef offset of each direction.

**Table 9-1560 SRSHARP0\_SR3\_DERING\_CTRL 0x3e6b**

Bit(s)	R/W	Default	Description
31	R/W		reserved
30:28	R/W	1	reg_sr3_dering_enable: dering enable
27	R/W		reserved
26:24	R/W	3	reg_sr3_dering_varlpf_mode: local variant LPF mode. 0: no filter; 1: erosion 3x3; 2: 3x3 lpf; 3: 3x3 erosion + lpf
23:20	R/W	9	reg_sr3_dering_maxrange: range of dering in LR resolution.
19:18	R/W		reserved
17:16	R/W	2	reg_sr3_dering_lcvar_blend_mode: mode for lcvar calculation. 0:HV blend; 1:diag blend; 2:HV blend + V; 3: HV blend+Diag blend
15:8	R/W	40	reg_sr3_dering_lcvar_gain: gain to local variant and normalized to 32 as 1
7:0	R/W	28	reg_sr3_dering_lcvar_nearby_maxsad_th: threshold to use near side maxsad if that side is larger than this threshold, otherwise use the max one.

**Table 9-1561 SRSHARP0\_SR3\_DERING\_LUMA2PKGAIN\_0TO3 0x3e6c**

Bit(s)	R/W	Default	Description
31:24	R/W	255	reg_sr3_dering_luma2pkgain3: level limit(for th0<bpcon<th1) of curve for dering pkgain base on LPF luma level
23:16	R/W	255	reg_sr3_dering_luma2pkgain2: level limit(for bpcon<th0) of curve for dering pkgain base on LPF luma level
15:8	R/W	200	reg_sr3_dering_luma2pkgain1: threshold 1 of curve for dering pkgain based on LPF luma level.
7:0	R/W	30	reg_sr3_dering_luma2pkgain0: threshold 0 of curve for dering pkgain based on LPF luma level.

**Table 9-1562 SRSHARP0\_SR3\_DERING\_LUMA2PKGAIN\_4TO6 0x3e6d**

Bit(s)	R/W	Default	Description
31:24	R/W		reserved
23:16	R/W	24	reg_sr3_dering_luma2pkgain6: rate1 (for bpcon>th1) of curve for dering pkOS based on LPF luma level.
15:8	R/W	50	reg_sr3_dering_luma2pkgain5: rate0 (for bpcon<th0) of curve for dering pkOS based on LPF luma level.
7:0	R/W	255	reg_sr3_dering_luma2pkgain4: level limit(for bpcon>th1) of curve for dering pkgain base on LPF luma level

**Table 9-1563 SRSHARP0\_SR3\_DERING\_LUMA2PKOS\_0TO3 0x3e6e**

Bit(s)	R/W	Default	Description
31:24	R/W	255	reg_sr3_dering_luma2pkos3: level limit(for th0<bpcon<th1) of curve for dering pkOS base on LPF luma level
23:16	R/W	255	reg_sr3_dering_luma2pkos2: level limit(for bpcon<th0) of curve for dering pkOS base on LPF luma level

Bit(s)	R/W	Default	Description
15:8	R/W	200	reg_sr3_dering_luma2pkos1: threshold 1 of curve for dering pkOS based on LPF luma level.
7:0	R/W	30	reg_sr3_dering_luma2pkos0: threshold 0 of curve for dering pkOS based on LPF luma level.

**Table 9-1564 SRSHARP0\_SR3\_DERING\_LUMA2PKOS\_4TO6 0x3e6f**

Bit(s)	R/W	Default	Description
31:24	R/W		reserved
23:16	R/W	24	reg_sr3_dering_luma2pkos6: rate1 (for bpcon>th1) of curve for dering pkOS based on LPF luma level.
15:8	R/W	50	reg_sr3_dering_luma2pkos5: rate0 (for bpcon<th0) of curve for dering pkOS based on LPF luma level.
7:0	R/W	255	reg_sr3_dering_luma2pkos4: level limit(for bpcon>th1) of curve for dering pkOS base on LPF luma level

**Table 9-1565 SRSHARP0\_SR3\_DERING\_GAINVS\_MADSAD 0x3e70**

Bit(s)	R/W	Default	Description
31:28	R/W	0	reg_sr3_dering_gainvs_maxsad7
27:24	R/W	0	reg_sr3_dering_gainvs_maxsad6
23:20	R/W	0	reg_sr3_dering_gainvs_maxsad5
19:16	R/W	0	reg_sr3_dering_gainvs_maxsad4
15:12	R/W	0	reg_sr3_dering_gainvs_maxsad3
11:8	R/W	0	reg_sr3_dering_gainvs_maxsad2
7:4	R/W	4	reg_sr3_dering_gainvs_maxsad1
3:0	R/W	8	reg_sr3_dering_gainvs_maxsad0: pkgain vs maxsad value, 8 node interpolations.

**Table 9-1566 SRSHARP0\_SR3\_DERING\_GAINVS\_VR2MAX 0x3e71**

Bit(s)	R/W	Default	Description
31:28	R/W	15	reg_sr3_dering_gainvs_vr2max7
27:24	R/W	15	reg_sr3_dering_gainvs_vr2max6
23:20	R/W	15	reg_sr3_dering_gainvs_vr2max5
19:16	R/W	15	reg_sr3_dering_gainvs_vr2max4
15:12	R/W	14	reg_sr3_dering_gainvs_vr2max3
11:8	R/W	12	reg_sr3_dering_gainvs_vr2max2
7:4	R/W	2	reg_sr3_dering_gainvs_vr2max1
3:0	R/W	0	reg_sr3_dering_gainvs_vr2max0: pkgain vs ratio

**Table 9-1567 SRSHARP0\_SR3\_DERING\_PARAM0 0x3e72**

Bit(s)	R/W	Default	Description
31:24	R/W		reserved
23:16	R/W	10	reg_sr3_dering_lcvar_floor
15:8	R/W	32	reg_sr3_dering_vr2max_gain: gain to max before feeding to LUT
7:6	R/W		reserved
5:0	R/W	16	reg_sr3_dering_vr2max_limt: limit of maxsad

**Table 9-1568 SRSHARP0\_SR3\_DRTLPF\_THETA 0x3e73**

Bit(s)	R/W	Default	Description
31:0	R/W	0xfe-c96420	reg_sr3_drtlpf_theta: u4x8 directional lpf beta coef for min_sad/min2_sad compared to x=0:7 correspond to [1:8]/16; 0 means no drtLPF, 15: 100% alpha dependant drtLPF.

**Table 9-1569 SRSHARP0\_SATPRT\_CTRL 0x3e74**

Bit(s)	R/W	Default	Description
31:28	R/W		reserved
27:16	R/W	5	reg_satprt_sat_core: 4x will be coring to cor(irgb_max-irgb_min) to calculate the oy_delt, the smaller the more protection to color, the larger only the rich color will be protected.
15:8	R/W	64	reg_satprt_sat_rate: rate to cor(irgb_max-irgb_min) to calculate the oy_delt, the larger the more protection to color; norm 16 as 1
7:4	R/W		reserved
3:2	R/W	1	reg_satprt_csc_mode: CSC mode of current yuv input: 0:601; 1:709; 2:BT2020 NCL; 3 reserved
1	R/W	1	reg_satprt_is_lmt: flag telling the YUV is limited range data or full rang data; 1 is limited data
0	R/W	0	reg_satprt_enable: 1 to enable of saturation protection for dnlp adjustments

**Table 9-1570 SRSHARP0\_SATPRT\_DIVM 0x3e75**

Bit(s)	R/W	Default	Description
31:24	R/W		reserved
23:0	R/W	{128,12-8,128}	reg_satprt_div_m: u8x3, 1/m, normalized to 128 as 1.

**Table 9-1571 SRSHARP0\_DB\_FLT\_CTRL 0x3e77**

Bit(s)	R/W	Default	Description
26	R/W	0	reg_nrdeband_reset1 : // unsigned , default = 0 0 : no reset seed 1: reload chroma seed
25	R/W	0	reg_nrdeband_reset0 : // unsigned , default = 0 0 : no reset seed 1: reload luma seed

Bit(s)	R/W	Default	Description
24	R/W	0	reg_nrdeband_rgb : // unsigned , default = 0 0 : yuv 1: RGB
23	R/W	1	reg_nrdeband_en11 : // unsigned , default = 1 debanding registers of side lines, [0] for luma, same for below
22	R/W	1	reg_nrdeband_en10 : // unsigned , default = 1 debanding registers of side lines, [1] for chroma, same for below
21	R/W	1	reg_nrdeband_siderand : // unsigned , default = 1 options to use side two lines use the rand, instead of use for the YUV three component of middle line, 0: seed [3]/bandrand[3] for middle line yuv; 1: seed[3]/bandrand[3] for nearby three lines Y;
20	R/W	0	reg_nrdeband_randmode : // unsigned , default = 0 mode of rand noise adding, 0: same noise strength for all difs; else: strenght of noise will not exceed the difs, MIN((pPKReg->reg_nrdeband_bandrand[m]), noise[m])
19:17	R/W	6	reg_nrdeband_bandrand2 : // unsigned , default = 6
15:13	R/W	6	reg_nrdeband_bandrand1 : // unsigned , default = 6
11: 9	R/W	6	reg_nrdeband_bandrand0 : // unsigned , default = 6
7	R/W	1	reg_nrdeband_hpxor1 : // unsigned , default = 1 debanding random hp portion xor, [0] for luma
6	R/W	1	reg_nrdeband_hpxor0 : // unsigned , default = 1 debanding random hp portion xor, [1] for chroma
5	R/W	1	reg_nrdeband_en1 : // unsigned , default = 1 debanding registers, for luma
4	R/W	1	reg_nrdeband_en0 : // unsigned , default = 1 debanding registers, for chroma
3: 2	R/W	2	reg_nrdeband_lpf_mode1 : // unsigned , default = 2 lpf mode, 0: 3x3, 1:3x5; 2: 5x5; 3:5x7
1: 0	R/W	2	reg_nrdeband_lpf_mode0 : // unsigned , default = 2 lpf mode, 0: 3x3, 1:3x5; 2: 5x5; 3:5x7

Table 9-1572 SRSHARP0\_DB\_FLT\_YC\_THRD 0x3e78

Bit(s)	R/W	Default	Description
31:28	R/W	9	reg_nrdeband_luma_th3 : // unsigned , default = 9 threshold to  Y-Y lpf , if < th [0] use lpf
27:24	R/W	7	reg_nrdeband_luma_th2 : // unsigned , default = 7 elseif <th[1] use (lpf*3 + y)/4
23:20	R/W	6	reg_nrdeband_luma_th1 : // unsigned , default = 6 elseif <th[1] use (lpf*3 + y)/4elseif <th[2] (lpf*1 + y)/2
19:16	R/W	5	reg_nrdeband_luma_th0 : // unsigned , default = 5 elseif <th[1] use (lpf*3 + y)/4elseif elseif <th[3] (lpf*1 + 3*y)/4; else
15:12	R/W	9	reg_nrdeband_chrm_th3 : // unsigned , default = 9 threshold to  Y-Y lpf , if < th [0] use lpf
11: 8	R/W	7	reg_nrdeband_chrm_th2 : // unsigned , default = 7 elseif <th[1] use (lpf*3 + y)/4
7: 4	R/W	6	reg_nrdeband_chrm_th1 : // unsigned , default = 6 elseif <th[1] use (lpf*3 + y)/4elseif <th[2] (lpf*1 + y)/2
3: 0	R/W	5	reg_nrdeband_chrm_th0 : // unsigned , default = 5 elseif <th[1] use (lpf*3 + y)/4elseif elseif

Table 9-1573 SRSHARP0\_DB\_FLT\_RANLUT 0x3e79

Bit(s)	R/W	Default	Description
23:21	R/W	1	reg_nrdeband_randslut7 : // unsigned , default = 1 lut0
20:18	R/W	1	reg_nrdeband_randslut6 : // unsigned , default = 1 lut0
17:15	R/W	1	reg_nrdeband_randslut5 : // unsigned , default = 1 lut0
14:12	R/W	1	reg_nrdeband_randslut4 : // unsigned , default = 1 lut0
11: 9	R/W	1	reg_nrdeband_randslut3 : // unsigned , default = 1 lut0
8: 6	R/W	1	reg_nrdeband_randslut2 : // unsigned , default = 1 lut0
5: 3	R/W	1	reg_nrdeband_randslut1 : // unsigned , default = 1 lut0
2: 0	R/W	1	reg_nrdeband_randslut0 : // unsigned , default = 1 lut0

Table 9-1574 SRSHARP0\_DB\_FLT\_PXI\_THRD 0x3e7a

Bit(s)	R/W	Default	Description
25:16	R/W	0	reg_nrdeband_yc_th1 : // unsigned , default = 0 to luma/ u/v  for using the denoise
9: 0	R/W	0	reg_nrdeband_yc_th0 : // unsigned , default = 0 to luma/ u/v  for using the denoise

Table 9-1575 SRSHARP0\_DB\_FLT\_SEED\_Y 0x3e7b

Bit(s)	R/W	Default	Description
31: 0	R/W	162143-8240	reg_nrdeband_seed0 : // unsigned , default = 1621438240 noise adding seed for Y. seed[0]= 0x60a52f20; as default

Table 9-1576 SRSHARP0\_DB\_FLT\_SEED\_U 0x3e7c

Bit(s)	R/W	Default	Description
31: 0	R/W	162143-8247	reg_nrdeband_seed1 : // unsigned , default = 1621438247 noise adding seed for U. seed[0]= 0x60a52f27; as default

Table 9-1577 SRSHARP0\_DB\_FLT\_SEED\_V 0x3e7d

Bit(s)	R/W	Default	Description
31: 0	R/W	162143-8242	reg_nrdeband_seed2 : // unsigned , default = 1621438242 noise adding seed for V. seed[0]= 0x60a52f22; as default

Table 9-1578 SRSHARP0\_PKGAIN\_VSLUMA\_LUT\_L 0x3e7e

Bit(s)	R/W	Default	Description
31:28	R/W	5	reg_pkgain_vsluma_lut7
27:24	R/W	6	reg_pkgain_vsluma_lut6
23:20	R/W	6	reg_pkgain_vsluma_lut5



Bit(s)	R/W	Default	Description
19:16	R/W	6	reg_pkgain_vsluma_lut4
15:12	R/W	7	reg_pkgain_vsluma_lut3
11:8	R/W	10	reg_pkgain_vsluma_lut2
7:4	R/W	12	reg_pkgain_vsluma_lut1
3:0	R/W	8	reg_pkgain_vsluma_lut0

Table 9-1579 SRSHARP0\_PKGAIN\_VSLUMA\_LUT\_H 0x3e7f

Bit(s)	R/W	Default	Description
31:4	R/W		reserved
3:0	R/W	4	reg_pkgain_vsluma_lut8

Table 9-1580 SRSHARP0\_PKOSHT\_VSLUMA\_LUT\_L 0x3e80

Bit(s)	R/W	Default	Description
31:28	R/W	5	reg_pkosht_vsluma_lut7
27:24	R/W	6	reg_pkosht_vsluma_lut6
23:20	R/W	6	reg_pkosht_vsluma_lut5
19:16	R/W	6	reg_pkosht_vsluma_lut4
15:12	R/W	7	reg_pkosht_vsluma_lut3
11:8	R/W	10	reg_pkosht_vsluma_lut2
7:4	R/W	12	reg_pkosht_vsluma_lut1
3:0	R/W	8	reg_pkosht_vsluma_lut0

Table 9-1581 SRSHARP0\_PKOSHT\_VSLUMA\_LUT\_H 0x3e81

Bit(s)	R/W	Default	Description
31:4	R/W		reserved
3:0	R/W	4	reg_pkosht_vsluma_lut8

Table 9-1582 SRSHARP0\_SATPRT\_LMT\_RGB1 0x3e82

Bit(s)	R/W	Default	Description
27:16	R/W	0d0	reg_satprt_lmt_g:
11: 0	R/W	0d0	reg_satprt_lmt_r: limit of RGB channel, for limited range RGB, 12bits

Table 9-1583 SRSHARP0\_SATPRT\_LMT\_RGB2 0x3e83

Bit(s)	R/W	Default	Description
31:16	R/W	0d0	reserved
11: 0	R/W	0d0	reg_satprt_lmt_b: limit of RGB channel, for limited range RGB

Table 9-1584 SRSHARP0\_SHARP\_GATE\_CLK\_CTRL\_0 0x3e84

Bit(s)	R/W	Default	Description
31:0	R/W	0d0	Gate clock control [01:00]: sharp input control unit [03:02]: deband unit [05:04]: dejaggy unit [07:06]: dnlp unit [09:08]: demo control unit [11:10]: horiz interp unit

Table 9-1585 SRSHARP0\_SHARP\_GATE\_CLK\_CTRL\_1 0x3e85

Bit(s)	R/W	Default	Description
31:0	R/W	0d0	Gate clock control [01:00]: sr_top "pipe_ctrl" [03:02]: drt [05:04]: ssd [07:06]: cubic [09:08]: edi [11:10]: pkgainsad [13:12]: bicomux [15:14]: bicin_fifo [17:16]: lpf4pkgain_fifo [19:18]: min2hvgain_fifo [21:20]: sad4pkgain_fifo [23:22]: dirminmax4xtl_fifo [25:24]: drtsad8_fifo [27:26]: ssdmax_fifo [29:28]: pkminmax_fifo [31:30]: cirdrtgain_fifo

Table 9-1586 SRSHARP0\_SHARP\_GATE\_CLK\_CTRL\_2 0x3e86

Bit(s)	R/W	Default	Description
31:0	R/W	0d0	Gate clock control [01:00]: bufdiff_fifo [03:02]: osvar_fifo [05:04]: pkhvgain unit [07:06]: pkgain unit [09:08]: Tl unit [11:10]: pk unit [13:12]: locvar unit [15:14]: hvconc unit

Table 9-1587 SRSHARP0\_SHARP\_GATE\_CLK\_CTRL\_3 0x3e87

Bit(s)	R/W	Default	Description
31:0	R/W	0d0	Gate clock control [01:00]: TI, htl Y [03:02]: TI, vti Y [05:04]: TI, htl U [07:06]: TI, vtl U [09:08]: TI, htl V [11:10]: TI, vtl V [13:12]: TI, lumaminmax_fifo [15:14]: TI, chrminmax_fifo

Table 9-1588 SRSHARP0\_SHARP\_DPS\_CTRL 0x3e88

Bit(s)	R/W	Default	Description
31:0	R/W	0d0	Power saving control [0] : hvcon [1] : nrssd [2] : os filter [3] : cubic 5 lines to 9 lines [4] : dering [5] : locvar [6] : drtlpf [7] : hlti [8] : hcti [9] : vlti [10] : vcti [11] : lti blend [12] : cti blend [13] : htishort (no used) [14] : nr Y filter [15] : nr C filter [16] : nr belnd [17] : pkti blend [18] : os ctrl [19] : pk HP [20] : pk BP [26:24] dejaggy power saving control [30:28] reserved

Table 9-1589 SRSHARP0\_DNLP\_00 0x3e90

Bit(s)	R/W	Default	Description
31: 0	R/W	0x0010-0008	reg_dnlp_ygrid0 :: dnlp00 . unsigned , default = 32'h00100008

Table 9-1590 SRSHARP0\_DNLP\_01 0x3e91

Bit(s)	R/W	Default	Description
31: 0	R/W	0x0020-0018	reg_dnlp_ygrid1 :: dnlp01 . unsigned , default = 32'h00200018

Table 9-1591 SRSHARP0\_DNLP\_02 0x3e92

Bit(s)	R/W	Default	Description
31: 0	R/W	0x0030-0028	reg_dnlp_ygrid2 :: dnlp02 . unsigned , default = 32'h00300028

**Table 9-1592 SRSHARP0\_DNLP\_03 0x3e93**

Bit(s)	R/W	Default	Description
31: 0	R/W	0x0040-0038	reg_dnlp_ygrid3 :: dnlp03 . unsigned , default = 32'h00400038

**Table 9-1593 SRSHARP0\_DNLP\_04 0x3e94**

Bit(s)	R/W	Default	Description
31: 0	R/W	0x0050-0048	reg_dnlp_ygrid4 :: dnlp04 . unsigned , default = 32'h00500048

**Table 9-1594 SRSHARP0\_DNLP\_05 0x3e95**

Bit(s)	R/W	Default	Description
31: 0	R/W	0x0068-005c	reg_dnlp_ygrid5 :: dnlp05 . unsigned , default = 32'h0068005c

**Table 9-1595 SRSHARP0\_DNLP\_06 0x3e96**

Bit(s)	R/W	Default	Description
31: 0	R/W	0x0080-0074	reg_dnlp_ygrid6 :: dnlp06 . unsigned , default = 32'h00800074

**Table 9-1596 SRSHARP0\_DNLP\_07 0x3e97**

Bit(s)	R/W	Default	Description
31: 0	R/W	0x00-a00090	reg_dnlp_ygrid7 :: dnlp07 . unsigned , default = 32'h00a00090

**Table 9-1597 SRSHARP0\_DNLP\_08 0x3e98**

Bit(s)	R/W	Default	Description
31: 0	R/W	0x00-c000b0	reg_dnlp_ygrid8 :: dnlp08 . unsigned , default = 32'h00c000b0

**Table 9-1598 SRSHARP0\_DNLP\_09 0x3e99**

Bit(s)	R/W	Default	Description
31: 0	R/W	0x00-e000d0	reg_dnlp_ygrid9 :: dnlp09 . unsigned , default = 32'h00e000d0

**Table 9-1599 SRSHARP0\_DNLP\_10 0x3e9a**

Bit(s)	R/W	Default	Description
31: 0	R/W	0x0100-00f0	reg_dnlp_ygrid10 :: dnlp10 . unsigned , default = 32'h010000f0

**Table 9-1600 SRSHARP0\_DNLP\_11 0x3e9b**

Bit(s)	R/W	Default	Description
31: 0	R/W	0x012-c0114	reg_dnlp_ygrid11 :: dnlp11 . unsigned , default = 32'h012c0114

**Table 9-1601 SRSHARP0\_DNLP\_12 0x3e9c**

Bit(s)	R/W	Default	Description
31: 0	R/W	0x0154-0140	reg_dnlp_ygrid12 :: dnlp12 . unsigned , default = 32'h01540140

**Table 9-1602 SRSHARP0\_DNLP\_13 0x3e9d**

Bit(s)	R/W	Default	Description
31: 0	R/W	0x0180-016c	reg_dnlp_ygrid13 :: dnlp13 . unsigned , default = 32'h0180016c

**Table 9-1603 SRSHARP0\_DNLP\_14 0x3e9e**

Bit(s)	R/W	Default	Description
31: 0	R/W	0x01-c001a0	reg_dnlp_ygrid14 :: dnlp14 . unsigned , default = 32'h01c001a0

**Table 9-1604 SRSHARP0\_DNLP\_15 0x3e9f**

Bit(s)	R/W	Default	Description
31: 0	R/W	0x0200-01e0	reg_dnlp_ygrid15 :: dnlp15 . unsigned , default = 32'h020001e0

**Table 9-1605 SRSHARP0\_DNLP\_16 0x3ea0**

Bit(s)	R/W	Default	Description
31: 0	R/W	0x0240-0220	reg_dnlp_ygrid16 :: dnlp16 . unsigned , default = 32'h02400220

**Table 9-1606 SRSHARP0\_DNLP\_17 0x3ea1**

Bit(s)	R/W	Default	Description
31: 0	R/W	0x0280-0260	reg_dnlp_ygrid17 :: dnlp17 . unsigned , default = 32'h02800260

**Table 9-1607 SRSHARP0\_DNLP\_18 0x3ea2**

Bit(s)	R/W	Default	Description
31: 0	R/W	0x02-b00298	reg_dnlp_ygrid18 :: dnlp18 . unsigned , default = 32'h02b00298

**Table 9-1608 SRSHARP0\_DNLP\_19 0x3ea3**

Bit(s)	R/W	Default	Description
31: 0	R/W	0x02-e002c8	reg_dnlp_ygrid19 :: dnlp19 . unsigned , default = 32'h02e002c8

**Table 9-1609 SRSHARP0\_DNLP\_20 0x3ea4**

Bit(s)	R/W	Default	Description
31: 0	R/W	0x0300-02f0	reg_dnlp_ygrid20 :: dnlp20 . unsigned , default = 32'h030002f0

**Table 9-1610 SRSHARP0\_DNLP\_21 0x3ea5**

Bit(s)	R/W	Default	Description
31: 0	R/W	0x0320-0310	reg_dnlp_ygrid21 :: dnlp21 . unsigned , default = 32'h03200310

**Table 9-1611 SRSHARP0\_DNLP\_22 0x3ea6**

Bit(s)	R/W	Default	Description
31: 0	R/W	0x0338-032c	reg_dnlp_ygrid22 :: dnlp22 . unsigned , default = 32'h0338032c

**Table 9-1612 SRSHARP0\_DNLP\_23 0x3ea7**

Bit(s)	R/W	Default	Description
31: 0	R/W	0x0350-0348	reg_dnlp_ygrid23 :: dnlp23 . unsigned , default = 32'h03500348

**Table 9-1613 SRSHARP0\_DNLP\_24 0x3ea8**

Bit(s)	R/W	Default	Description
31: 0	R/W	0x035-c0358	reg_dnlp_ygrid24 :: dnlp24 . unsigned , default = 32'h035c0358

**Table 9-1614 SRSHARP0\_DNLP\_25 0x3ea9**

Bit(s)	R/W	Default	Description
31: 0	R/W	0x0368-0360	reg_dnlp_ygrid25 :: dnlp25 . unsigned , default = 32'h03680360

**Table 9-1615 SRSHARP0\_DNLP\_26 0x3eaa**

Bit(s)	R/W	Default	Description
31: 0	R/W	0x0378-0370	reg_dnlp_ygrid26 :: dnlp26 . unsigned , default = 32'h03780370

**Table 9-1616 SRSHARP0\_DNLP\_27 0x3eab**

Bit(s)	R/W	Default	Description
31: 0	R/W	0x0388-0380	reg_dnlp_ygrid27 :: dnlp27 . unsigned , default = 32'h03880380

**Table 9-1617 SRSHARP0\_DNLP\_28 0x3eac**

Bit(s)	R/W	Default	Description
31: 0	R/W	0x03-a00390	reg_dnlp_ygrid28 :: dnlp28 . unsigned , default = 32'h03a00390

**Table 9-1618 SRSHARP0\_DNLP\_29 0x3ead**

Bit(s)	R/W	Default	Description
31: 0	R/W	0x03-c003b0	reg_dnlp_ygrid29 :: dnlp29 . unsigned , default = 32'h03c003b0

**Table 9-1619 SRSHARP0\_DNLP\_30 0x3eae**

Bit(s)	R/W	Default	Description
31: 0	R/W	0x03-e003d0	reg_dnlp_ygrid30 :: dnlp30 . unsigned , default = 32'h03e003d0

**Table 9-1620 SRSHARP0\_DNLP\_31 0x3eaf**

Bit(s)	R/W	Default	Description
31: 0	R/W	0x03f-c03f0	reg_dnlp_ygrid31 :: dnlp31 . unsigned , default = 32'h03fc03f0

### 9.2.3.30 VKSTONE Registers

**Table 9-1621 VKS\_CTRL 0x3100**

Bit(s)	R/W	Default	Description
31	W	1	reg_vks_en : // unsigned , default = 1 enable signal of the vks function need set high in every frme
30	R/W	1	reg_vks_scl_mode0 : // unsigned , default = 1 : b0 mode of vks ofset mode, 0: offset= offset; 1: offset= offset*step= ofset/scale;
29	R/W	1	reg_vks_scl_mode1 : // unsigned , default = 1 : b0 mode of vks ofset mode, 0: offset= offset; 1: offset= offset*step= ofset/scale;
28	R/W	1	reg_vks_fill_mode : // unsigned , default = 1 mode of out-of-boundary fill, 0 extension, 1: fill with the fill_value
27:26	R/W	1	reg_vks_row_inp_mode : // unsigned , default = 1 , interpolation mode from 16pieces ofset/step to each line ofset and step; 0: linear interpolation; 1: cubic interpolation (using ccoef)

Bit(s)	R/W	Default	Description
25	R/W	0	reg_vks_border_ext_mode0 : // unsigned , default = 0 , extend mode of the border data of luma and chroma, 0: copy the most border one; 1: extrapolate the border one
24	R/W	0	reg_vks_border_ext_mode1 : // unsigned , default = 0 , extend mode of the border data of luma and chroma, 0: copy the most border one; 1: extrapolate the border one
23	R/W	1	reg_vks_obuf_mode0 : // unsigned , default = 1 , mode of output buffer left/right side. 0: no precalculate active pixels during output fill region; 1: precalc active pixels during output fill regions
22	R/W	1	reg_vks_obuf_mode1 : // unsigned , default = 1 , mode of output buffer left/right side. 0: no precalculate active pixels during output fill region; 1: precalc active pixels during output fill regions
21:20	R/W	3	reg_vks_obuf_mrqn0 : // unsigned , default = 3 , margin pixels for left right most active pixel to the fill pixels to avoid jump
19:18	R/W	3	reg_vks_obuf_mrqn1 : // unsigned , default = 3 , margin pixels for left right most active pixel to the fill pixels to avoid jump
17:16	R/W	2	reg_vks_phs_qmode : // unsigned , default = 2 , interpolation mode of the phase, 0: floor to 1/64 phase; 1: round to 1/64 phase; 2/3 linear intp
15: 0	R/W	11651	reg_vks_row_scl : // unsigned , default = 11651 , scale of row to make it fit to the 16 pieces, scl = (2^23)/RowMax

Table 9-1622 VKS\_OUT\_WIN\_SIZE 0x3101

Bit(s)	R/W	Default	Description
29:16	R/W	1280	reg_vks_ocolmax : // unsigned , default = 1280 output outer window col number, decided by the projector
13: 0	R/W	720	reg_vks_orowmax : // unsigned , default = 720 output outer window row number, decided by the projector

Table 9-1623 VKS\_PRELPF\_YCOEF0 0x3102

Bit(s)	R/W	Default	Description
31:24	R/W	0x0	reg_vks_prelpf_ycoef0 : // signed , default = -128 coef of horizontal luma prelpf for Keystone, normalized 128 as '1'
23:16	R/W	0	reg_vks_prelpf_ycoef1 : // signed , default = 0 coef of horizontal luma prelpf for Keystone, normalized 128 as '1'
15: 8	R/W	0	reg_vks_prelpf_ycoef2 : // signed , default = 0 coef of horizontal luma prelpf for Keystone, normalized 128 as '1'
7: 0	R/W	0	reg_vks_prelpf_ycoef3 : // signed , default = 0 coef of horizontal luma prelpf for Keystone, normalized 128 as '1'

Table 9-1624 VKS\_PRELPF\_YCOEF1 0x3103

Bit(s)	R/W	Default	Description
15: 8	R/W	0	reg_vks_prelpf_ycoef4 : // signed , default = 0 coef of horizontal luma prelpf for Keystone, normalized 128 as '1'
7: 0	R/W	0	reg_vks_prelpf_ycoef5 : // signed , default = 0 coef of horizontal luma prelpf for Keystone, normalized 128 as '1'



**Table 9-1625 VKS\_PRELPF\_CCOEF0 0x3104**

Bit(s)	R/W	Default	Description
31:24	R/W	0x0	reg_vks_prelpf_ccoef0 : // signed , default = -128 mode of horizontal chroma prelpf for Keystone, normalized 128 as '1'
23:16	R/W	0	reg_vks_prelpf_ccoef1 : // signed , default = 0 mode of horizontal chroma prelpf for Keystone, normalized 128 as '1'
15: 8	R/W	0	reg_vks_prelpf_ccoef2 : // signed , default = 0 mode of horizontal chroma prelpf for Keystone, normalized 128 as '1'
7: 0	R/W	0	reg_vks_prelpf_ccoef3 : // signed , default = 0 mode of horizontal chroma prelpf for Keystone, normalized 128 as '1'

**Table 9-1626 VKS\_PRELPF\_CCOEF1 0x3105**

Bit(s)	R/W	Default	Description
15: 8	R/W	0	reg_vks_prelpf_ccoef4 : // signed , default = 0 mode of horizontal chroma prelpf for Keystone, normalized 128 as '1'
7: 0	R/W	0	reg_vks_prelpf_ccoef5 : // signed , default = 0 mode of horizontal chroma prelpf for Keystone, normalized 128 as '1'

**Table 9-1627 VKS\_FILL\_VAL 0x3106**

Bit(s)	R/W	Default	Description
23:16	R/W	0	reg_vks_fill_value0 : // unsigned , default = 0 , border fill color define. yuv: [0 128 128]; rgb:[0 0 0] ,use 8 bits in 12bit path,6bits in 10bit path
15: 8	R/W	128	reg_vks_fill_value1 : // unsigned , default = 128 , border fill color define. yuv: [0 128 128]; rgb:[0 0 0] ,use 8 bits in 12bit path,6bits in 10bit path
7: 0	R/W	128	reg_vks_fill_value2 : // unsigned , default = 128 , border fill color define. yuv: [0 128 128]; rgb:[0 0 0] ,use 8 bits in 12bit path,6bits in 10bit path

**Table 9-1628 VKS\_IWIN\_HSIZE 0x3107**

Bit(s)	R/W	Default	Description
29:16	R/W	160	reg_vks_iwinx0 : // unsigned , default = 160 , input start-col and end-col;
13: 0	R/W	1279	reg_vks_iwinx1 : // unsigned , default = 1279 , input start-col and end-col;

**Table 9-1629 VKS\_IWIN\_VSIZE 0x3108**

Bit(s)	R/W	Default	Description
29:16	R/W	0	reg_vks_iwiny0 : // unsigned , default = 0 , input start-row and end-row;
13: 0	R/W	719	reg_vks_iwiny1 : // unsigned , default = 719 , input start-row and end-row;

**Table 9-1630 VKS\_TOP\_MISC 0x3109**

Bit(s)	R/W	Default	Description
18	R/W	1	regflt_en : // unsigned , default = 1
17	R/W	0	regfrm_rst : // unsigned , default = 0
16	R/W	0	regctrl_sync : // unsigned , default = 0
15: 8	R/W	4	blank_num : // unsigned , default = 4
7: 0	R/W	9	flt_blank_num : // unsigned , default = 9

**Table 9-1631 VKS\_START\_CTRL 0x310a**

Bit(s)	R/W	Default	Description
16	R/W	0	regvks_en_mode : // unsigned , default = 0
15: 0	R/W	5	reg_hold_phnum : // unsigned , default = 5

**Table 9-1632 VKS\_LBUF\_SIZE 0x310b**

Bit(s)	R/W	Default	Description
11: 0	R/W	1024	reg_lbuf_depth : // unsigned , default = 1024

**Table 9-1633 VKS\_PARA\_ADDR\_PORT 0x310e**

Bit(s)	R/W	Default	Description
31: 0	R/W	3ff	Access address for vkstone para_lut, start address must be 0x09

**Table 9-1634 VKS\_PARA\_DATA\_PORT 0x310f**

Bit(s)	R/W	Default	Description
31: 0	R/W	/	Data access for vkstone para lut

Below are the detail registers of VKS\_PARA\_DATA\_PORT and VKS\_PARA\_ADDR\_PORT control:

**Table 9-1635 VKS\_SCL\_OFFSET00 ~ VKS\_SCL\_OFFSET16 0X09~0X19**

Bit(s)	R/W	Default	Description
31:20			reserved
19: 0	R/W	/	Left offset of the input pixel offset from the left 12bits pixel and 8 bits float phase

**Table 9-1636 VKS\_SCL\_STEP00 ~ VKS\_SCL\_STEP16 0X1A~0X2A**

Bit(s)	R/W	Default	Description
24:20			reserved
23: 0	R/W	/	Unsigned reg_scl_stepx for ratio of each line(defined piece), step:4.20 opxium = (ipxium << 20)/step scale:4.2 = 1/step

Table 9-1637 VKS\_PPS\_YCOEF00 ~ VKS\_PPS\_YCOEF32 0X2B~0X4B

Bit(s)	R/W	Default	Description
31:24	R/W	/	Signed reg_vks_ycoef0 Poly_phase scalar coef
23:16	R/W	/	Signed reg_vks_ycoef1 Poly_phase scalar coef
15:8	R/W	/	Signed reg_vks_ycoef2 Poly_phase scalar coef
7: 0	R/W	/	Signed reg_vks_ycoef3 Poly_phase scalar coef

Table 9-1638 VKS\_PPS\_CCOEF00 ~ VKS\_PPS\_CCOEF32 0X4C~0X6C

Bit(s)	R/W	Default	Description
31:24	R/W	/	Signed reg_vks_ccoef0 Poly_phase scalar coef
23:16	R/W	/	Signed reg_vks_ccoef1 Poly_phase scalar coef
15:8	R/W	/	Signed reg_vks_ccoef2 Poly_phase scalar coef
7: 0	R/W	/	Signed reg_vks_ccoef3 Poly_phase scalar coef

### 9.2.3.31 OSD1 Registers

Table 9-1639 VIU\_OSD1\_CTRL\_STAT 0x1A10

Bit(s)	R/W	Default	Description
31	R/W	0	osd_cfg_syn_en : // unsigned , default =0 1: module enable sync by go_field 0: normal
30	R/W	0	ENABLE_FREE_CLK. 1 = Use free-running clock; 0 = Use gated clock to save power.
29	R	0	TEST_RD_DSR: Applicable only when OSD debug mode is enabled. 1 = A new pixel is ready at register VIU_OSD1_TEST_RDDATA; 0 = No data ready.
/	/	/	/
27-24	R	0	OSD_BLK_MODE: the input pixel format of which the current OSD block is being processed. Mali src & normal src have different pixel format value for same format
23-22	R	0	OSD_BLK_PTR: The number of the current OSD block that is being processed.
21	R	0	OSD_ENABLE. 1 = OSD display is enabled; 0 = disabled.
20-12	R/W	0	GLOBAL_ALPHA: legal range 0 – 256. It is a 9-bit value that is multiplied to all output pixel's Alpha value, and then normalized, i.e.: $\text{Alpha\_tmp} = \text{Alpha\_internal} + (\text{Alpha\_internal} == 0 ? 0 : 1);$ $\text{Alpha\_out} = (\text{Alpha\_tmp} * \text{GLOBAL\_ALPHA}) / 256;$
11	R/W	0	TEST_RD_EN: OSD debug mode enable. 1 = Output pixels are not routed to VPP, instead they are presented on registers VIU_OSD1_TEST_RDDATA, for CPU to read. 0 = Normal mode, pixels are output to VPP.
10-9	R/W	0	unused

Bit(s)	R/W	Default	Description
8-5	R/W	0	<p>CTRL_MTCH_Y: For OSD 444, 422 or 16-bit (COLOR_MATRIX = 0 or 1) mode, the input pixels contain no Alpha information, in order to associated the output pixel with an Alpha value, the following steps are taken:</p> <p>If TC_ALPHA_EN = 0, then all output pixels use a default Alpha value 0xFF;</p> <p>If TC_ALPHA_EN = 1, then the Alpha value is looked up by matching the pixel's Y/Cb/Cr against four Alpha registers' Y/Cb/Cr. If the pixel matches any one of the Alpha registers, then this register's Alpha value is used; If the pixel matches with more than one of the Alpha registers, then the lower Alpha register takes priority, e.g. use Alpha Reg0's value if the pixel match both Alpha Reg0 and Reg1; If no match, then use default Alpha value 0xFF.</p> <p>There are two ways of matching: one way is that the pixel has to compare all Y, Cb and Cr value with the Alpha registers; the other way is that the pixel only has to compare Y value with the Alpha registers. CTRL_MTCH_Y defines which way is used to determine a match.</p> <p>Bit[0] is for matching Alpha register 0: 1 = only need to compare Y; 0 = compare all Y, Cb and Cr.</p> <p>Bit[1] is for matching Alpha register 1: 1 = only need to compare Y; 0 = compare all Y, Cb and Cr.</p> <p>Bit[2] is for matching Alpha register 2: 1 = only need to compare Y; 0 = compare all Y, Cb and Cr.</p> <p>Bit[3] is for matching Alpha register 3: 1 = only need to compare Y; 0 = compare all Y, Cb and Cr.</p>
4	R/W	0	<p>CTRL_422TO444.</p> <p>1 = Enable conversion of 422 format input to 444 format output;</p> <p>0 = Disable 422 to 444 conversion.</p>
/	/	/	/
2	R/W	0	<p>osd_mem_mode : // unsigned , default =0</p> <p>0:canvas_araddr</p> <p>1: linear_araddr (mali src must use this mode)</p>
1	R/W	0	premult_en : // unsigned , default =0
0	R/W	0	OSD_BLK_ENABLE: Each bit to enable display an OSD block

Table 9-1640 VIU\_OSD1\_CTRL\_STAT2 0x1A2d

Bit(s)	R/W	Default	Description
31-16	R	0	unused
15	R/W	0	unused
14	R/W	0	Replaced_alpha_en
13-6	R/W	0	Replaced_alpha
5-4	R/W	0	Hold_fifo_lines[6:5]
3	R/W	0	<p>RGBYUV_FULL_RANGE: Select coefficients for applicable output range.</p> <p>1 = output full range 0-255;</p> <p>0 = output range 16-235.</p>
2	R/W	0	<p>ALPHA_9B_MODE: Define how to expand 8-bit alpha value to 9-bit.</p> <p>1 = The formula is (Alpha &lt; 128) ? Alpha : Alpha + 1;</p> <p>0 = The formula is (Alpha == 0) ? Alpha : Alpha + 1.</p>
1	R/W	0	Pedding status cleanup
0	R/W	0	<p>COLOR_EXPAND_MODE.</p> <p>1 = Expand the color components to 8-bit by padding LSBs with MSBs. E.g. If the input is 5'b11000, the output is expanded to 8'b11000110;</p> <p>0 = Expand the color components to 8-bit by padding LSBs with 0.</p>

**Table 9-1641 VIU\_OSD1\_COLOR\_ADDR 0x1A11**

Bit(s)	R/W	Default	Description
31-9	R	0	Unused
8	R/W	1	0 = Write LUT, 1 = Read LUT.
7-0	R/W	0	LUT_ADDR: For 2-bit, 4-bit and 8-bit color lookup mode. The initial read or write address of the look-up table.

**Table 9-1642 VIU\_OSD1\_COLOR 0x1A12**

Bit(s)	R/W	Default	Description
31-24	R/W	0	Current LUT entry's Y or R.
23-16	R/W	0	Current LUT entry's CB or G.
15-8	R/W	0	Current LUT entry's CR or B.
7-0	R/W	0	Current LUT entry's ALPHA.

VIU\_OSD1\_TCOLOR\_AG0 0x1A17

VIU\_OSD1\_TCOLOR\_AG1 0x1A18

VIU\_OSD1\_TCOLOR\_AG2 0x1A19

VIU\_OSD1\_TCOLOR\_AG3 0x1A1a

**Table 9-1643 Define Alpha register 0/1/2/3 values.**

Bit(s)	R/W	Default	Description
31-24	R/W	0xFF	Y or R.
23-16	R/W	0xFF	CB or G.
15-8	R/W	0xFF	CR or B.
7-0	R/W	0xFF	ALPHA.

**Table 9-1644 VIU\_OSD1\_BLK0\_CFG\_W0 0x1A1b Defines display block 0/1/2/3's property, word 0.**

Bit(s)	R/W	Default	Description
31	R/W	0	Reserved
30	R/W	0	mali_src_en 1: read data from mali afbcd decoder 0: read data from DDR directly
29	R/W	0	y_rev: 0=normal read, 1=reverse read in Y direction
28	R/W	0	x_rev: 0=normal read, 1=reverse read in X direction
27-24	R/W	0	Reserved
23-16	R/W	0	TBL_ADDR. Virtual canvas LUT entry.
15	R/W	0	LITTLE_ENDIAN: define the of data stored in DDR. 1 = Data stored in DDR memory are of little endian; 0 = Data stored in DDR memory are of big endian.
14	R/W	0	RPT_Y: For reducing data size stored in DDR.

Bit(s)	R/W	Default	Description
			1 = For each line, OSD will display twice; 0 = No repeat, OSD display once per line.
13-12	R/W	0	INTERP_CTRL: If enabled, interpolate a data after each incoming pixels, in order to save DDR bandwidth. 0 = No interpolation; 1 = unused, no interpolation; 2 = Interpolate with preceding pixel value; 3 = Interpolate with the averaged value between the preceding pixel and the next pixel.
11-8	R/W	0	OSD_BLK_MODE: Define the OSD block's input pixel format according bit30. Bit30 == 0: 0 = 2-bit per pixel, totally 4 colors can be looked up from color palette LUT, Only OSD2 have; 1 = 4-bit per pixel, totally 16 colors can be looked up from color palette LUT, Only OSD2 have; 2 = 8-bit per pixel, totally 256 colors can be looked up from color palette LUT, Only OSD2 have; 3 = 4:2:2 mode. Input 32-bit data for 2 pixels. Bit[31:24] is Y0, bit [23:16] is Cb0, bit[15:8] is Y1, bit [7:0] is Cr0, for Alpha value refer to reg VIU_OSD1_CTRL_STAT.CTRL_MTCH_Y; 4 = 16-bit mode. Refer to COLOR_MATRIX; 5 = 32-bit mode. Refer to COLOR_MATRIX; 6 = unused; 7 = 24-bit mode. Refer to COLOR_MATRIX; 8-15 = unused; Bit30 == 1: 0:R8 1:8bit yuv422 2:RGB565 3:RGBA5551 4:RGBA4444 5:RGBA8888 7:RGB888 8:10bit yuv422 9:RGBA1010102 Other:unuse
6	R/W	0	TC_ALPHA_EN: refer to reg VIU_OSD1_CTRL_STAT.CTRL_MTCH_Y. 1 = Enable alpha register matching. 0 = Disable.
5-2	R/W	0	COLOR_MATRIX: Applicable only to 16-bit color mode (OSD_BLK_MODE=4), 32-bit mode (OSD_BLK_MODE=5) and 24-bit mode (OSD_BLK_MODE=7), defines the bit-field allocation of the pixel data. For expanding the bit-fields to full 8-bit, refer to VIU_OSD1_CTRL_STAT2.color_expand_mode and VIU_OSD1_CTRL_STAT2.alpha_expand_mode. For 16-bit mode (OSD_BLK_MODE=4): 0 = 6:5:5 format. Bit[15:10] is Y[7:2] or R[7:2], bit[9:5] is Cb[7:3] or G[7:3], bit[4:0] is Cr[7:3] or B[7:3], for Alpha value refer to reg VIU_OSD1_CTRL_STAT.CTRL_MTCH_Y; 1 = 8:4:4 format. Bit[15:8] is Y or R, bit[7:4] is Cb[7:4] or G[7:4], bit[3:0] is Cr[7:4] or B[7:4], for Alpha value refer to reg VIU_OSD1_CTRL_STAT.CTRL_MTCH_Y; 2 = 6:4:4:2 format. Bit[15:10] is Y[7:2] or R[7:2], bit[9:6] is Cb[7:4] or G[7:4], bit[5:2] is Cr[7:4] or B[7:4], bit[1:0] is Alpha[7:6]; 3 = 4:4:4:4 format. Bit[15:12] is Y[7:4] or R[7:4], bit[11:8] is Cb[7:4] or G[7:4], bit[7:4] is Cr[7:4] or B[7:4], bit[3:0] is Alpha[7:4]; 4 = 5:6:5 format. Bit [15:11] is Y[7:3] or R[7:3], bit[10:5] is Cb[7:2] or G[7:2], bit[4:0] is Cr[7:3] or B[7:3], for Alpha value refer to reg VIU_OSD1_CTRL_STAT.CTRL_MTCH_Y; 5 = 4:4:4:4 format. Bit[15:12] is Alpha[7:4], bit[11:8] is Y[7:4] or R[7:4], bit[7:4] is Cb[7:4] or G[7:4], bit[3:0] is Cr[7:4] or B[7:4]; 6 = 1:5:5:5 format. Bit[15] is Alpha[7], bit[14:10] is Y[7:3] or R[7:3], bit[9:5] is Cb[7:3] or G[7:3], bit[4:0] is Cr[7:3] or B[7:3]; 7 = 4:6:4:2 format. Bit[15:12] is Y[7:4] or R[7:4], bit[11:6] is Cb[7:2] or G[7:2], bit[5:2] is Cr[7:4] or B[7:4], bit[1:0] is Alpha[1:0]. For 32-bit mode (OSD_BLK_MODE=5): 0 = RGBA 8:8:8:8 format. Bit[31:24] is Y or R, bit[23:16] is Cb or G; bit[15:8] is Cr or B; bit[7:0] is Alpha; 1 = ARGB 8:8:8:8 format. Bit[31:24] is Alpha, bit[23:16] is Y or R; bit[15:8] is Cb or G; bit[7:0] is Cr or B; 2 = ABGR 8:8:8:8 format. Bit[31:24] is Alpha, bit[23:16] is Cr or B; bit[15:8] is Cb or G; bit[7:0] is Y or R; 3 = BGRA 8:8:8:8 format. Bit[31:24] is Cr or B, bit[23:16] is Cb or G; bit [15:8] is Y or R; bit[7:0] is Alpha. For 24-bit mode (OSD_BLK_MODE=7): 0 = RGB 8:8:8 mode. Bit[23:16] is Y or R, bit[15:8] is Cb or G, bit[7:0] is Cr or B, for Alpha value refer to reg VIU_OSD1_CTRL_STAT.CTRL_MTCH_Y; 1 = RGBA 5:6:5:8 mode. Bit[23:19] is Y[7:3] or R[7:3], bit[18:13] is Cb[7:2] or G[7:2], bit [12:8] is Cr[7:3] or B[7:3], bit[7:0] is Alpha; 2 = ARGB 8:5:6:5 mode. Bit[23:16] is Alpha, bit[15:11] is Y[7:3] or R[7:3], bit[10:5] is Cb[7:2] or G[7:2], bit[4:0] is Cr[7:3] or B[7:3]; 3 = RGBA 6:6:6:6 mode. Bit[23:18] is Y[7:2] or R[7:2], bit[17:12] is Cb [7:2] or G[7:2], bit[11:6] is Cr[7:2] or B[7:2], bit[5:0] is Alpha[7:2]; 4 = ARGB 6:6:6:6 mode. Bit[23:18] is Alpha[7:2];, bit[17:12] is Y[7:2] or R[7:2], bit[11:6] is

Bit(s)	R/W	Default	Description
			Cb[7:2] or G[7:2], bit[5:0] is Cr[7:2] or B[7:2]; 5 = BGR 8:8:8 mode. Bit[23:16] is Cr or B, bit[15:8] is Cb or G, bit[7:0] is Y or R, for Alpha value refer to reg VIU_OSD1_CTRL_STAT.CTRL_MTCH_Y.
1	R/W	0	INTERLACE_EN. 1 = Enable interlace mode. 0 = Disable.
0	R/W	0	INTERLACE_SEL_ODD: Applicable only if INTERLACE_EN = 1. 1 = Only output odd lines; 0 = Only output even lines.

**Table 9-1645 VIU\_OSD1\_BLK0\_CFG\_W1 0x1A1c Defines display block 0/1/2/3's property, word 1.**

Bit(s)	R/W	Default	Description
31-29	R/W	0	Unused.
28-16	R/W	0	X_END. Virtual canvas co-ordinate.
15-13	R/W	0	Unused.
12-0	R/W	0	X_START. Virtual canvas co-ordinate.

**Table 9-1646 VIU\_OSD1\_BLK0\_CFG\_W2 0x1A1d Defines display block 0/1/2/3's property, word 2.**

Bit(s)	R/W	Default	Description
31-29	R/W	0	Unused.
28-16	R/W	0	Y_END. Virtual canvas co-ordinate.
15-13	R/W	0	Unused.
12-0	R/W	0	Y_START. Virtual canvas co-ordinate.

**Table 9-1647 VIU\_OSD1\_BLK0\_CFG\_W3 0x1A1e Defines display block 0/1/2/3's property, word 3.**

Bit(s)	R/W	Default	Description
31-28	R/W	0	Unused.
27-16	R/W	0	H_END. Display horizontal co-ordinate.
15-12	R/W	0	Unused.
11-0	R/W	0	H_START. Display horizontal co-ordinate.

**Table 9-1648 VIU\_OSD1\_BLK0\_CFG\_W4 0x1A13 Defines display block 0/1/2/3's property, word 4.**

Bit(s)	R/W	Default	Description
31-28	R/W	0	Unused.
27-16	R/W	0	V_END. Display vertical co-ordinate.

Bit(s)	R/W	Default	Description
15-12	R/W	0	Unused.
11-0	R/W	0	V_START. Display vertical co-ordinate.

Table 9-1649 VIU\_OSD1\_BLK1\_CFG\_W4 0x1a14

Bit(s)	R/W	Default	Description
31:0	R/W	0	Frame_addr: // unsigned , default =0 Frame_addr in linear_addr

Table 9-1650 VIU\_OSD1\_BLK2\_CFG\_W4 0x1a15

Bit(s)	R/W	Default	Description
31:0	R/W	0	Line_stride : // unsigned , default =0 Line_stride in linear_addr

Table 9-1651 VIU\_OSD1\_FIFO\_CTRL\_STAT 0x1A2b

Bit(s)	R/W	Default	Description
31	R/W	0	burst_len_sel[2] of [2:0]
30	R/W	0	BYTE_SWAP: In addition to endian control, further define whether to swap upper byte and lower byte within a 16-bit memory word. 1 = Swap, data[15:0] becomes {data[7:0], data[15:8]}; 0 = No swap, data[15:0] is still data[15:0].
29	R/W	0	Div_swap : swap the 2 64bits word in 128bits word
28-24	R/W	0	Fifo_lim : when osd fifo is small than the fifo_lim*16, closed the req port of osd_rd_mif
23-22	R/W	0	Fifo_ctrl: 00 : for 1 word in 1 burst, 01 : for 2words in 1burst, 10 : for 4 words in 1burst, 11: reserved
21-20	R	0	FIFO_ST: State of the FIFO activity. 0 = Idle; 1 = FIFO requesting; 2 = FIFO request aborting.
19	R	0	FIFO_OVERFLOW.
18-12	R/W	32	FIFO_DEPTH_VAL: Define the depth of FIFO which stores 128-bit data from DDR to be FIFO_DEPTH_VAL * 8.
11-10	R/W	0	BURST_LEN_SEL[1:0] of [2:0]: Define DDR burst request length. 0 = up to 24 per burst; 1 = up to 32 per burst; 2 = up to 48 per burst;/ 3 = up to 64 per burst. 4 = up to 96 per burst, 5 = up to 128 per burst
9-5	R/W	4	HOLD_FIFO_LINES: The number of lines that OSD must wait after VSYNC, before it starts request data from DDR .
4	R/W	0	CLEAR_ERR: One pulse to clear error status.
3	R/W	0	FIFO_SYNC_RST: Set 1 to reset OSD FIFO.



Bit(s)	R/W	Default	Description
2-1	R/W	0	ENDIAN: define the endianness of the 64-bit data stored in memory, and how to convert. 0 = No conversion; 1 = Convert to {din[31:0], din[63:32]}; 2 = Convert to {din[15:0], din[31:16], din[47:32], din[63:48]}; 3 = Convert to {din[47:32], din[63:48], din[15:0], din[31:16]};
0	R/W	0	URGENT. 1 = Set DDR request priority to be urgent; 0 = Set DDR request priority to be normal.

During OSD debug mode (VIU\_OSD1\_CTRL\_STAT.TEST\_RD\_EN = 1), the output pixels will be presented at this register.

**Table 9-1652 VIU\_OSD1\_TEST\_RDDATA 0x1A2c**

Bit(s)	R/W	Default	Description
31-24	R	0	Y or R.
23:16	R	0	Cb or G.
15-8	R	0	Cr or B.
7-0	R	0	Alpha[8:1].

**Table 9-1653 VIU\_OSD1\_PROT\_CTRL 0x1a2e**

Bit(s)	R/W	Default	Description
31:16	R/W	0	urgent_ctrl : // unsigned , default =0
15	R.O	0	prot_en : // unsigned , default =0; 1=Borrow PROT's FIFO storage, either for rotate or non-rotate.
12: 0	R.O	0	prot_fifo_size : // unsigned , default =0; effective FIFO size when prot_en=1.

**Table 9-1654 VIU\_OSD1\_MALI\_UNPACK\_CTRL 0x1a2f**

Bit(s)	R/W	Default	Description
31	R/W	0	mali_unpack_en 1: OSD will unpack mali_src 0: OSD will unpack normal src
28			Alpha_div_en: alpha divisor enable
27:26			Alpha_divisor gating clk
25:24			Alpa_mapping_mode In osd, this bit should be set 0 when Alpha_div_en active, means 8 bits alpha mode
17	/	/	/
16	R/W	0	afbcd_swap_64bit:
15: 12	R/W	1	afbcd_r_reorder, change osd output order when use mali src: 1: r_re = r ; 2: r_re = g ; 3: r_re = b ; 4: r_re = a ;

Bit(s)	R/W	Default	Description
			default: r_re = 0;
11: 8		2	afbcd_r_reorder,change osd output order when use mali src: 1: g_re = r ; 2: g_re = g; 3: g_re = b; 4: g_re = a; default: r_re = 0;
7: 4		3	afbcd_r_reorder,change osd output order when use mali src: 1: b_re = r ; 2: b_re = g; 3: b_re = b; 4: b_re = a; default: r_re = 0;
3: 0		4	afbcd_r_reorder,change osd output order when use mali src: 1: a_re = r ; 2: a_re = g; 3: a_re = b; 4: a_re = a; default: r_re = 0;

Table 9-1655 VIU\_OSD1\_DIMM\_CTRL 0x1adf

Bit(s)	R/W	Default	Description
30	R/W	0	OSD dimm enable,osd out will be one color when this bit active
29:0	R/W	0	Osd_dim_rgb_out ,osd out will be this vaaule when bit30 active

### 9.2.3.32 OSD2 Registers

VIU\_OSD2\_CTRL\_STAT 0x1a30

See: VIU\_OSD1\_CTRL\_STAT

VIU\_OSD2\_CTRL\_STAT2 0x1a4d

See: VIU\_OSD1\_CTRL\_STAT2

VIU\_OSD2\_COLOR\_ADDR 0x1a31

See: VIU\_OSD1\_COLOR\_ADDR

VIU\_OSD2\_COLOR 0x1a32

See: VIU\_OSD1\_COLOR

VIU\_OSD2\_TCOLOR\_AG0 0x1a37

See: VIU\_OSD1\_TCOLOR\_AG0

VIU\_OSD2\_TCOLOR\_AG1 0x1a38

See: VIU\_OSD1\_TCOLOR\_AG1

VIU\_OSD2\_TCOLOR\_AG2 0x1a39

See: VIU\_OSD1\_TCOLOR\_AG02

VIU\_OSD2\_TCOLOR\_AG3 0x1a3a

See: VIU\_OSD1\_TCOLOR\_AG3

VIU\_OSD2\_BLK0\_CFG\_W0 0x1a3b

See: VIU\_OSD1\_BLK0\_CFG\_W0

VIU\_OSD2\_BLK0\_CFG\_W1 0x1a3c

See: VIU\_OSD1\_BLK0\_CFG\_W1

VIU\_OSD2\_BLK0\_CFG\_W2 0x1a3d

See: VIU\_OSD1\_BLK0\_CFG\_W2

VIU\_OSD2\_BLK0\_CFG\_W3 0x1a3e

See: VIU\_OSD1\_BLK0\_CFG\_W3

VIU\_OSD2\_BLK0\_CFG\_W4 0x1a64

See: VIU\_OSD1\_BLK0\_CFG\_W4

VIU\_OSD2\_BLK1\_CFG\_W4 0x1a65

See: VIU\_OSD2\_BLK1\_CFG\_W4

VIU\_OSD2\_BLK2\_CFG\_W4 0x1a66

See: VIU\_OSD1\_BLK2\_CFG\_W4

VIU\_OSD2\_FIFO\_CTRL\_STAT 0x1a4b

See: VIU\_OSD1\_FIFO\_CTRL\_STAT

VIU\_OSD2\_TEST\_RDDATA 0x1a4c

See: VIU\_OSD1\_TEST\_RDDATA

VIU\_OSD2\_PROT\_CTRL 0x1a4e

See: VIU\_OSD1\_PROT\_CTRL

VIU\_OSD2\_MALI\_UNPACK\_CTRL 0x1abd

See: VIU\_OSD1\_MALI\_UNPACK\_CTRL

VIU\_OSD2\_DIMM\_CTRL 0x1acf

See: VIU\_OSD1\_DIMM\_CTRL

### 9.2.3.33 OSD3 Registers

VIU\_OSD3\_CTRL\_STAT 0x3d80

See: VIU\_OSD1\_CTRL\_STAT

VIU\_OSD3\_CTRL\_STAT2 0x3d81

See: VIU\_OSD1\_CTRL\_STAT2

VIU\_OSD3\_COLOR\_ADDR 0x3d82

See: VIU\_OSD1\_COLOR\_ADDR

VIU\_OSD3\_COLOR 0x3d83

See: VIU\_OSD1\_COLOR

VIU\_OSD3\_TCOLOR\_AG0 0x3d84

See: VIU\_OSD1\_TCOLOR\_AG0

VIU\_OSD3\_TCOLOR\_AG1 0x3d85

See: VIU\_OSD1\_TCOLOR\_AG1

VIU\_OSD3\_TCOLOR\_AG2 0x3d86

See: VIU\_OSD1\_TCOLOR\_AG02

VIU\_OSD3\_TCOLOR\_AG3 0x3d87

See: VIU\_OSD1\_TCOLOR\_AG3

VIU\_OSD3\_BLK0\_CFG\_W0 0x3d88

See: VIU\_OSD1\_BLK0\_CFG\_W0

VIU\_OSD3\_BLK0\_CFG\_W1 0x3d8c

See: VIU\_OSD1\_BLK0\_CFG\_W1

VIU\_OSD3\_BLK0\_CFG\_W2 0x3d90

See: VIU\_OSD1\_BLK0\_CFG\_W2

VIU\_OSD3\_BLK0\_CFG\_W3 0x3d94

See: VIU\_OSD1\_BLK0\_CFG\_W3

VIU\_OSD3\_BLK0\_CFG\_W4 0x3d98

See: VIU\_OSD1\_BLK0\_CFG\_W4

VIU\_OSD3\_BLK1\_CFG\_W4 0x3d99

See: VIU\_OSD3\_BLK1\_CFG\_W4

VIU\_OSD3\_BLK2\_CFG\_W4 0x3d9a

See: VIU\_OSD1\_BLK2\_CFG\_W4

VIU\_OSD3\_FIFO\_CTRL\_STAT 0x3d9c

See: VIU\_OSD1\_FIFO\_CTRL\_STAT

VIU\_OSD3\_TEST\_RDDATA 0x3d9d

See: VIU\_OSD1\_TEST\_RDDATA

VIU\_OSD3\_PROT\_CTRL 0x3d9e

See: VIU\_OSD1\_PROT\_CTRL

VIU\_OSD3\_MALI\_UNPACK\_CTRL 0x3d9f

See: VIU\_OSD1\_MALI\_UNPACK\_CTRL

VIU\_OSD3\_DIMM\_CTRL 0x3da0

See: VIU\_OSD1\_DIMM\_CTRL

### 9.2.3.34 VPP\_VD1\_MATRIX Registers

Table 9-1656 VPP\_VD1\_MATRIX VPP\_VD1\_MATRIX\_COEF00\_01 0x3290

Bit(s)	R/W	Default	Description
28-16	R/W	0	Coefficient00, signed, 3.10
12-0	R/W	0	Coefficient01, signed, 3.10

**Table 9-1657 VPP\_VD1\_MATRIX\_COEF02\_10 0x3291**

Bit(s)	R/W	Default	Description
28-16	R/W	0	Coefficient02, signed, 3.10
12-0	R/W	0	Coefficient10, signed, 3.10

**Table 9-1658 VPP\_VD1\_MATRIX\_COEF11\_12 0x3292**

Bit(s)	R/W	Default	Description
28-16	R/W	0	Coefficient11, signed, 3.10
12-0	R/W	0	Coefficient12, signed, 3.10

**Table 9-1659 VPP\_VD1\_MATRIX\_COEF20\_21 0x3293**

Bit(s)	R/W	Default	Description
28-16	R/W	0	Coefficient20, signed, 3.10
12-0	R/W	0	Coefficient21, signed, 3.10

**Table 9-1660 VPP\_VD1\_MATRIX\_COEF22 0x3294**

Bit(s)	R/W	Default	Description
18-16	R/W	0	convrs
12-0	R/W	0	Coefficient22, signed, 3.10

**Table 9-1661 VPP\_VD1\_MATRIX\_COEF13\_14 0x3295**

Bit(s)	R/W	Default	Description
28-16	R/W	0	Coefficient13, signed, 3.10
12-0	R/W	0	Coefficient14, signed, 3.10

**Table 9-1662 VPP\_VD1\_MATRIX\_COEF23\_24 0x3296**

Bit(s)	R/W	Default	Description
28-16	R/W	0	Coefficient23, signed, 3.10
12-0	R/W	0	Coefficient24, signed, 3.10

**Table 9-1663 VPP\_VD1\_MATRIX\_COEF15\_25 0x3297**

Bit(s)	R/W	Default	Description
28-16	R/W	0	Coefficient15, signed, 3.10
12-0	R/W	0	Coefficient25, signed, 3.10

**Table 9-1664 VPP\_VD1\_MATRIX\_CLIP 0x3298**

Bit(s)	R/W	Default	Description
31-8	R/W	0x0	reserved
7-5	R/W	0x1	Matrix rs
4-3	R/W	0x10	Matrix clmod 0: only 3x3, 1: pre_offseted_ch1,ch2> pre_offseted_ch0, use the added 2x3 coef 2: pre_offseted_ch1,ch2 > 0, use the added 2x3 coef 3: pre_offseted_ch1,ch2 > 512, use the added 2x3 coef
2-0	R/W	0x10	/

**Table 9-1665 VPP\_VD1\_MATRIX\_OFFSET0\_1 0x3299**

Bit(s)	R/W	Default	Description
27-16	R/W	0	Offset0, signed value
11-0	R/W	0	Offset1, signed value

**Table 9-1666 VPP\_VD1\_MATRIX\_OFFSET2 0x329a**

Bit(s)	R/W	Default	Description
11-0	R/W	0	Offset2, signed value

**Table 9-1667 VPP\_VD1\_MATRIX\_PRE\_OFFSET0\_1 0x329b**

Bit(s)	R/W	Default	Description
27-16	R/W	0	pre_Offset0, signed value
11-0	R/W	0	Pre_Offset1, signed value

**Table 9-1668 VPP\_VD1\_MATRIX\_PRE\_OFFSET2 0x329c**

Bit(s)	R/W	Default	Description
11-0	R/W	0	Pre_Offset2, signed value

**Table 9-1669 VPP\_VD1\_MATRIX\_EN\_CTRL 0x329d**

Bit(s)	R/W	Default	Description
5:4	R/W	0	Gate clock ctrl
1	R/W	0	Enable_sync_sel
0	R/W	0	Conv_en_pre

### 9.2.3.35 VPP\_POST\_MATRIX Registers

VPP\_POST\_MATRIX\_COEF00\_01 0x32b0

See: VPP\_VD1\_MATRIX\_COEF00\_01

VPP\_POST\_MATRIX\_COEF02\_10 0x32b1

See: VPP\_VD1\_MATRIX\_COEF02\_10

VPP\_POST\_MATRIX\_COEF11\_12 0x32b2

See: VPP\_VD1\_MATRIX\_COEF11\_12

VPP\_POST\_MATRIX\_COEF20\_21 0x32b3

See: VPP\_VD1\_MATRIX\_COEF20\_21

VPP\_POST\_MATRIX\_COEF22 0x32b4

See: VPP\_VD1\_MATRIX\_COEF22

VPP\_POST\_MATRIX\_COEF13\_14 0x32b5

See: VPP\_VD1\_MATRIX\_COEF13\_14

VPP\_POST\_MATRIX\_COEF23\_24 0x32b6

See: VPP\_VD1\_MATRIX\_COEF23\_24

VPP\_POST\_MATRIX\_COEF15\_25 0x32b7

See: VPP\_VD1\_MATRIX\_COEF15\_25

VPP\_POST\_MATRIX\_CLIP 0x32b8

See: VPP\_VD1\_MATRIX\_CLIP

VPP\_POST\_MATRIX\_OFFSET0\_1 0x32b9

See: VPP\_VD1\_MATRIX\_OFFSET0\_1

VPP\_POST\_MATRIX\_OFFSET2 0x32ba

See: VPP\_VD1\_MATRIX\_OFFSET2

VPP\_POST\_MATRIX\_PRE\_OFFSET0\_1 0x32bb

See: VPP\_VD1\_MATRIX\_PRE\_OFFSET0\_1

VPP\_POST\_MATRIX\_PRE\_OFFSET2 0x32bc

See: VPP\_VD1\_MATRIX\_PRE\_OFFSET2

VPP\_POST\_MATRIX\_EN\_CTRL 0x32bd

See: VPP\_VD1\_MATRIX\_EN\_CTRL

**Table 9-1670 VPP\_POST\_MATRIX\_SAT 0x32c1**

Bit(s)	R/W	Default	Description
2	R/W	0	sat_o_en: If true, the output result of post matrix output is saturated
1	R/W	0	sat_i_en: If true, the input result of post matrix output is saturated
0	R/W	0	misc_sat_en: same as sat_i_en



### 9.2.3.36 VPP\_POST2\_MATRIX Registers

VPP\_POST2\_MATRIX\_COEF00\_01 0x39a0

See: VPP\_VD1\_MATRIX\_COEF00\_01

VPP\_POST2\_MATRIX\_COEF02\_10 0x39a1

See: VPP\_VD1\_MATRIX\_COEF02\_10

VPP\_POST2\_MATRIX\_COEF11\_12 0x39a2

See: VPP\_VD1\_MATRIX\_COEF11\_12

VPP\_POST2\_MATRIX\_COEF20\_21 0x39a3

See: VPP\_VD1\_MATRIX\_COEF20\_21

VPP\_POST2\_MATRIX\_COEF22 0x39a4

See: VPP\_VD1\_MATRIX\_COEF22

VPP\_POST2\_MATRIX\_COEF13\_14 0x39a5

See: VPP\_VD1\_MATRIX\_COEF13\_14

VPP\_POST2\_MATRIX\_COEF23\_24 0x39a6

See: VPP\_VD1\_MATRIX\_COEF23\_24

VPP\_POST2\_MATRIX\_COEF15\_25 0x39a7

See: VPP\_VD1\_MATRIX\_COEF15\_25

VPP\_POST2\_MATRIX\_CLIP 0x39a8

See: VPP\_VD1\_MATRIX\_CLIP

VPP\_POST2\_MATRIX\_OFFSET0\_1 0x39a9

See: VPP\_VD1\_MATRIX\_OFFSET0\_1

VPP\_POST2\_MATRIX\_OFFSET2 0x39aa

See: VPP\_VD1\_MATRIX\_OFFSET2

VPP\_POST2\_MATRIX\_PRE\_OFFSET0\_1 0x39ab

See: VPP\_VD1\_MATRIX\_PRE\_OFFSET0\_1

VPP\_POST2\_MATRIX\_PRE\_OFFSET2 0x39ac

See: VPP\_VD1\_MATRIX\_PRE\_OFFSET2

VPP\_POST2\_MATRIX\_EN\_CTRL 0x39ad

See: VPP\_VD1\_MATRIX\_EN\_CTRL

### 9.2.3.37 VPP\_OSD2\_MATRIX Registers

VPP\_OSD2\_MATRIX\_COEF00\_01 0x3920

See: VPP\_VD1\_MATRIX\_COEF00\_01

VPP\_OSD2\_MATRIX\_COEF02\_10 0x3921

See: VPP\_VD1\_MATRIX\_COEF02\_10

VPP\_OSD2\_MATRIX\_COEF11\_12 0x3922

See: VPP\_VD1\_MATRIX\_COEF11\_12

VPP\_OSD2\_MATRIX\_COEF20\_21 0x3923

See: VPP\_VD1\_MATRIX\_COEF20\_21

VPP\_OSD2\_MATRIX\_COEF22 0x3924

See: VPP\_VD1\_MATRIX\_COEF22

VPP\_OSD2\_MATRIX\_COEF13\_14 0x3925

See: VPP\_VD1\_MATRIX\_COEF13\_14

VPP\_OSD2\_MATRIX\_COEF23\_24 0x3926

See: VPP\_VD1\_MATRIX\_COEF23\_24

VPP\_OSD2\_MATRIX\_COEF15\_25 0x3927

See: VPP\_VD1\_MATRIX\_COEF15\_25

VPP\_OSD2\_MATRIX\_CLIP 0x3928

See: VPP\_VD1\_MATRIX\_CLIP

VPP\_OSD2\_MATRIX\_OFFSET0\_1 0x3929

See: VPP\_VD1\_MATRIX\_OFFSET0\_1

VPP\_OSD2\_MATRIX\_OFFSET2 0x392a

See: VPP\_VD1\_MATRIX\_OFFSET2

VPP\_OSD2\_MATRIX\_PRE\_OFFSET0\_1 0x392b

See: VPP\_VD1\_MATRIX\_PRE\_OFFSET0\_1

VPP\_OSD2\_MATRIX\_PRE\_OFFSET2 0x392c

See: VPP\_VD1\_MATRIX\_PRE\_OFFSET2

VPP\_OSD2\_MATRIX\_EN\_CTRL 0x392d

See: VPP\_VD1\_MATRIX\_EN\_CTRL

### 9.2.3.38 VPP\_WRAP\_OSD1\_MATRIX Registers

VPP\_WRAP\_OSD1\_MATRIX\_COEF00\_01 0x3d60

See: VPP\_VD1\_MATRIX\_COEF00\_01

VPP\_WRAP\_OSD1\_MATRIX\_COEF02\_10 0x3d61

See: VPP\_VD1\_MATRIX\_COEF02\_10

VPP\_WRAP\_OSD1\_MATRIX\_COEF11\_12 0x3d62

See: VPP\_VD1\_MATRIX\_COEF11\_12

VPP\_WRAP\_OSD1\_MATRIX\_COEF20\_21 0x3d63

See: VPP\_VD1\_MATRIX\_COEF20\_21

VPP\_WRAP\_OSD1\_MATRIX\_COEF22 0x3d64

See: VPP\_VD1\_MATRIX\_COEF22

VPP\_WRAP\_OSD1\_MATRIX\_COEF13\_14 0x3d65

See: VPP\_VD1\_MATRIX\_COEF13\_14

VPP\_WRAP\_OSD1\_MATRIX\_COEF23\_24 0x3d66

See: VPP\_VD1\_MATRIX\_COEF23\_24

VPP\_WRAP\_OSD1\_MATRIX\_COEF15\_25 0x3d67

See: VPP\_VD1\_MATRIX\_COEF15\_25

VPP\_WRAP\_OSD1\_MATRIX\_CLIP 0x3d68

See: VPP\_VD1\_MATRIX\_CLIP

VPP\_WRAP\_OSD1\_MATRIX\_OFFSET0\_1 0x3d69

See: VPP\_VD1\_MATRIX\_OFFSET0\_1

VPP\_WRAP\_OSD1\_MATRIX\_OFFSET2 0x3d6a

See: VPP\_VD1\_MATRIX\_OFFSET2

VPP\_WRAP\_OSD1\_MATRIX\_PRE\_OFFSET0\_1 0x3d6b

See: VPP\_VD1\_MATRIX\_PRE\_OFFSET0\_1

VPP\_WRAP\_OSD1\_MATRIX\_PRE\_OFFSET2 0x3d6c

See: VPP\_VD1\_MATRIX\_PRE\_OFFSET2

VPP\_WRAP\_OSD1\_MATRIX\_EN\_CTRL 0x3d6d

See: VPP\_VD1\_MATRIX\_EN\_CTRL

### 9.2.3.39 VPP\_WRAP\_OSD2\_MATRIX Registers

VPP\_WRAP\_OSD2\_MATRIX\_COEF00\_01 0x3d70

See: VPP\_VD1\_MATRIX\_COEF00\_01

VPP\_WRAP\_OSD2\_MATRIX\_COEF02\_10 0x3d71

See: VPP\_VD1\_MATRIX\_COEF02\_10

VPP\_WRAP\_OSD2\_MATRIX\_COEF11\_12 0x3d72

See: VPP\_VD1\_MATRIX\_COEF11\_12

VPP\_WRAP\_OSD2\_MATRIX\_COEF20\_21 0x3d73

See: VPP\_VD1\_MATRIX\_COEF20\_21

VPP\_WRAP\_OSD2\_MATRIX\_COEF22 0x3d74

See: VPP\_VD1\_MATRIX\_COEF22

VPP\_WRAP\_OSD2\_MATRIX\_COEF13\_14 0x3d75

See: VPP\_VD1\_MATRIX\_COEF13\_14

VPP\_WRAP\_OSD2\_MATRIX\_COEF23\_24 0x3d76

See: VPP\_VD1\_MATRIX\_COEF23\_24

VPP\_WRAP\_OSD2\_MATRIX\_COEF15\_25 0x3d77

See: VPP\_VD1\_MATRIX\_COEF15\_25

VPP\_WRAP\_OSD2\_MATRIX\_CLIP 0x3d78

See: VPP\_VD1\_MATRIX\_CLIP

VPP\_WRAP\_OSD2\_MATRIX\_OFFSET0\_1 0x3d79

See: VPP\_VD1\_MATRIX\_OFFSET0\_1

VPP\_WRAP\_OSD2\_MATRIX\_OFFSET2 0x3d7a

See: VPP\_VD1\_MATRIX\_OFFSET2

VPP\_WRAP\_OSD2\_MATRIX\_PRE\_OFFSET0\_1 0x3d7b

See: VPP\_VD1\_MATRIX\_PRE\_OFFSET0\_1

VPP\_WRAP\_OSD2\_MATRIX\_PRE\_OFFSET2 0x3d7c

See: VPP\_VD1\_MATRIX\_PRE\_OFFSET2

VPP\_WRAP\_OSD2\_MATRIX\_EN\_CTRL 0x3d7d

See: VPP\_VD1\_MATRIX\_EN\_CTRL

### 9.2.3.40 VPP\_WRAP\_OSD3\_MATRIX Registers

VPP\_WRAP\_OSD3\_MATRIX\_COEF00\_01 0x3db0

See: VPP\_VD1\_MATRIX\_COEF00\_01

VPP\_WRAP\_OSD3\_MATRIX\_COEF02\_10 0x3db1

See: VPP\_VD1\_MATRIX\_COEF02\_10

VPP\_WRAP\_OSD3\_MATRIX\_COEF11\_12 0x3db2

See: VPP\_VD1\_MATRIX\_COEF11\_12

VPP\_WRAP\_OSD3\_MATRIX\_COEF20\_21 0x3db3

See: VPP\_VD1\_MATRIX\_COEF20\_21

VPP\_WRAP\_OSD3\_MATRIX\_COEF22 0x3db4

See: VPP\_VD1\_MATRIX\_COEF22

VPP\_WRAP\_OSD3\_MATRIX\_COEF13\_14 0x3db5

See: VPP\_VD1\_MATRIX\_COEF13\_14

VPP\_WRAP\_OSD3\_MATRIX\_COEF23\_24 0x3db6

See: VPP\_VD1\_MATRIX\_COEF23\_24

VPP\_WRAP\_OSD3\_MATRIX\_COEF15\_25 0x3db7

See: VPP\_VD1\_MATRIX\_COEF15\_25

VPP\_WRAP\_OSD3\_MATRIX\_CLIP 0x3db8

See: VPP\_VD1\_MATRIX\_CLIP

VPP\_WRAP\_OSD3\_MATRIX\_OFFSET0\_1 0x3db9

See: VPP\_VD1\_MATRIX\_OFFSET0\_1

VPP\_WRAP\_OSD3\_MATRIX\_OFFSET2 0x3dba

See: VPP\_VD1\_MATRIX\_OFFSET2

VPP\_WRAP\_OSD3\_MATRIX\_PRE\_OFFSET0\_1 0x3dbb

See: VPP\_VD1\_MATRIX\_PRE\_OFFSET0\_1

VPP\_WRAP\_OSD3\_MATRIX\_PRE\_OFFSET2 0x3dbc

See: VPP\_VD1\_MATRIX\_PRE\_OFFSET2

VPP\_WRAP\_OSD3\_MATRIX\_EN\_CTRL 0x3dbd

See: VPP\_VD1\_MATRIX\_EN\_CTRL

### 9.2.3.41 HDR Registers

Table 9-1671 HDR VDIN0\_HDR2\_CTRL 0x1280

Bit(s)	R/W	Default	Description
20:18	R/W	0	reg_din_swap : // unsigned , default = 0
17	R/W	0	reg_out_fmt : // unsigned , default = 0
16	R/W	0	reg_only_mat : // unsigned , default = 0 ,only use input matrix ,work when hdr disable
15	R/W	0	mat_o_en, //output matrix enable ,only work when hdr enable
14	R/W	0	mat_in_en //input matrix enable ,only work when hdr enable
13	R/W	0	reg_VDIN0_HDR2_top_en : // unsigned , default = 0, hdr enable singal
12	R/W	1	reg_cgain_mode : // unsigned , default = 1
7: 6	R/W	1	reg_gmut_mode : // unsigned , default = 1
5	R/W	0	reg_in_shift : // unsigned , default = 0
4	R/W	1	reg_in_fmt : // unsigned , default = 1
3	R/W	1	reg_eo_enable : // unsigned , default = 1
2	R/W	1	reg_oe_enable : // unsigned , default = 1
1	R/W	1	reg_ogain_enable : // unsigned , default = 1
0	R/W	1	reg_cgain_enable : // unsigned , default = 1

**Table 9-1672 VDIN0\_HDR2\_CLK\_GATE 0x1281**

Bit(s)	R/W	Default	Description
31:30	R/W	0	clk_tm : gate clock ctrl (main clock) // unsigned , default = 0
29:28	R/W	0	output : matrix clock gate ctrl// unsigned , default = 0
25:24	R/W	0	input : matrix clock gate ctrl // unsigned , default = 0
23:22	R/W	0	hdr : top cbus clock gate ctrl // unsigned , default = 0
21:20	R/W	0	eotf : cbus clock gate ctrl // unsigned , default = 0
19:18	R/W	0	oetf : cbus clock gate ctrl // unsigned , default = 0
17:16	R/W	0	gamma : mult cbus clock gate ctrl // unsigned , default = 0
15:14	R/W	0	adaptive : cbus scaler clock gate ctrl // unsigned , default = 0
13:12	R/W	0	cgain : cbus clock gate ctrl// unsigned , default = 0
11:10	R/W	0	eotf : clock gate ctrl // unsigned , default = 0
9:8	R/W	0	oetf : clock gate ctrl // unsigned , default = 0
7:6	R/W	0	gamma : mult clock gate ctrl// unsigned , default = 0
5:4	R/W	0	adaptive : scaler clock gate ctrl // unsigned , default = 0
3:2	R/W	0	uv : gain clock gate ctrl // unsigned , default = 0
1:0	R/W	0	cgain : clock gate ctrl // unsigned , default = 0

**Table 9-1673 VDIN0\_HDR2\_MATRIXI\_COEF00\_01 0x1282**

Bit(s)	R/W	Default	Description
28:16	R/W	0	coef00 : // signed , default = 0
12:0	R/W	0	coef01 : // signed , default = 0

**Table 9-1674 VDIN0\_HDR2\_MATRIXI\_COEF02\_10 0x1283**

Bit(s)	R/W	Default	Description
28:16	R/W	0	coef02 : // signed , default = 0
12:0	R/W	0	coef10 : // signed , default = 0

**Table 9-1675 VDIN0\_HDR2\_MATRIXI\_COEF11\_12 0x1284**

Bit(s)	R/W	Default	Description
28:16	R/W	0	coef11 : // signed , default = 0
12:0	R/W	0	coef12 : // signed , default = 0

**Table 9-1676 VDIN0\_HDR2\_MATRIXI\_COEF20\_21 0x1285**

Bit(s)	R/W	Default	Description
28:16	R/W	0	coef20 : // signed , default = 0
12:0	R/W	0	coef21 : // signed , default = 0

**Table 9-1677 VDIN0\_HDR2\_MATRIXI\_COEF22 0x1286**

Bit(s)	R/W	Default	Description
12:0	R/W	0	coef22 : // signed , default = 0

**Table 9-1678 VDIN0\_HDR2\_MATRIXI\_COEF30\_31 0x1287**

Bit(s)	R/W	Default	Description
28:16	R/W	0	coef13 : // signed , default = 0
12:0	R/W	0	coef14 : // signed , default = 0

**Table 9-1679 VDIN0\_HDR2\_MATRIXI\_COEF32\_40 0x1288**

Bit(s)	R/W	Default	Description
28:16	R/W	0	coef23 : // signed , default = 0
12:0	R/W	0	coef24 : // signed , default = 0

**Table 9-1680 VDIN0\_HDR2\_MATRIXI\_COEF41\_42 0x1289**

Bit(s)	R/W	Default	Description
28:16	R/W	0	coef15 : // signed , default = 0
12:0	R/W	0	coef25 : // signed , default = 0

**Table 9-1681 VDIN0\_HDR2\_MATRIXI\_OFFSET0\_1 0x128A**

Bit(s)	R/W	Default	Description
26:16	R/W	0	offset0 : // signed , default = 0
10:0	R/W	0	offset1 : // signed , default = 0

**Table 9-1682 VDIN0\_HDR2\_MATRIXI\_OFFSET2 0x128B**

Bit(s)	R/W	Default	Description
10:0	R/W	0	offset2 : // signed , default = 0



**Table 9-1683 VDIN0\_HDR2\_MATRIXI\_PRE\_OFFSET0\_1 0x128C**

Bit(s)	R/W	Default	Description
26:16	R/W	0	pre_offset0 : // signed , default = 0
10:0	R/W	0	pre_offset1 : // signed , default = 0

**Table 9-1684 VDIN0\_HDR2\_MATRIXI\_PRE\_OFFSET2 0x128D**

Bit(s)	R/W	Default	Description
10:0	R/W	0	pre_offset2 : // signed , default = 0

**Table 9-1685 VDIN0\_HDR2\_MATRIXO\_COEF00\_01 0x128E**

Bit(s)	R/W	Default	Description
28:16	R/W	0	coef00 : // signed , default = 0
12:0	R/W	0	coef01 : // signed , default = 0

**Table 9-1686 VDIN0\_HDR2\_MATRIXO\_COEF02\_10 0x128F**

Bit(s)	R/W	Default	Description
28:16	R/W	0	coef02 : // signed , default = 0
12:0	R/W	0	coef10 : // signed , default = 0

**Table 9-1687 VDIN0\_HDR2\_MATRIXO\_COEF11\_12 0x1290**

Bit(s)	R/W	Default	Description
28:16	R/W	0	coef11 : // signed , default = 0
12:0	R/W	0	coef12 : // signed , default = 0

**Table 9-1688 VDIN0\_HDR2\_MATRIXO\_COEF20\_21 0x1291**

Bit(s)	R/W	Default	Description
28:16	R/W	0	coef20 : // signed , default = 0
12:0	R/W	0	coef21 : // signed , default = 0

**Table 9-1689 VDIN0\_HDR2\_MATRIXO\_COEF22 0x1292**

Bit(s)	R/W	Default	Description
12:0	R/W	0	coef22 : // signed , default = 0

**Table 9-1690 VDIN0\_HDR2\_MATRIXO\_COEF30\_31 0x1293**

Bit(s)	R/W	Default	Description
28:16	R/W	0	coef13 : // signed , default = 0
12:0	R/W	0	coef14 : // signed , default = 0

**Table 9-1691 VDIN0\_HDR2\_MATRIXO\_COEF32\_40 0x1294**

Bit(s)	R/W	Default	Description
28:16	R/W	0	coef23 : // signed , default = 0
12:0	R/W	0	coef24 : // signed , default = 0

**Table 9-1692 VDIN0\_HDR2\_MATRIXO\_COEF41\_42 0x1295**

Bit(s)	R/W	Default	Description
28:16	R/W	0	coef15 : // signed , default = 0
12:0	R/W	0	coef25 : // signed , default = 0

**Table 9-1693 VDIN0\_HDR2\_MATRIXO\_OFFSET0\_1 0x1296**

Bit(s)	R/W	Default	Description
26:16	R/W	0	offset0 : // signed , default = 0
10:0	R/W	0	offset1 : // signed , default = 0

**Table 9-1694 VDIN0\_HDR2\_MATRIXO\_OFFSET2 0x1297**

Bit(s)	R/W	Default	Description
10:0	R/W	0	offset2 : // signed , default = 0

**Table 9-1695 VDIN0\_HDR2\_MATRIXO\_PRE\_OFFSET0\_1 0x1298**

Bit(s)	R/W	Default	Description
26:16	R/W	0	pre_offset0 : // signed , default = 0
10:0	R/W	0	pre_offset1 : // signed , default = 0

**Table 9-1696 VDIN0\_HDR2\_MATRIXO\_PRE\_OFFSET2 0x1299**

Bit(s)	R/W	Default	Description
10:0	R/W	0	pre_offset2 : // signed , default = 0

**Table 9-1697 VDIN0\_HDR2\_MATRIXI\_CLIP 0x129A**

Bit(s)	R/W	Default	Description
19:8	R/W	0	comp_th : // unsigned , default = 0
7:5	R/W	0	conv_rs : // unsigned , default = 0
4:3	R/W	0	clmod : // unsigned , default = 0

**Table 9-1698 VDIN0\_HDR2\_MATRIXO\_CLIP 0x129B**

Bit(s)	R/W	Default	Description
19:8	R/W	0	comp_th : // unsigned , default = 0
7:5	R/W	0	conv_rs : // unsigned , default = 0
4:3	R/W	0	clmod : // unsigned , default = 0

**Table 9-1699 VDIN0\_HDR2\_CGAIN\_OFFT 0x129C**

Bit(s)	R/W	Default	Description
26:16	R/W	0	reg_cgain_offt2 : // signed , default = 0
10:0	R/W	0	reg_cgain_offt1 : // signed , default = 0

**Table 9-1700 VDIN0\_EOTF\_LUT\_ADDR\_PORT 0x129E**

Bit(s)	R/W	Default	Description
7:0	R/W	0	eotf_lut_addr : // unsigned , default = 0

**Table 9-1701 VDIN0\_EOTF\_LUT\_DATA\_PORT 0x129F**

Bit(s)	R/W	Default	Description
19:0	R/W	0	eotf_lut_data : // unsigned , default = 0

**Table 9-1702 VDIN0\_OETF\_LUT\_ADDR\_PORT 0x12A0**

Bit(s)	R/W	Default	Description
7:0	R/W	0	oetf_lut_addr : // unsigned , default = 0

**Table 9-1703 VDIN0\_OETF\_LUT\_DATA\_PORT 0x12A1**

Bit(s)	R/W	Default	Description
11:0	R/W	0	oetf_lut_data : // unsigned , default = 0

**Table 9-1704 VDIN0\_CGAIN\_LUT\_ADDR\_PORT 0x12A2**

Bit(s)	R/W	Default	Description
7:0	R/W	0	cgain_lut_addr : // unsigned , default = 0

**Table 9-1705 VDIN0\_CGAIN\_LUT\_DATA\_PORT 0x12A3**

Bit(s)	R/W	Default	Description
11:0	R/W	0	cgain_lut_data : // unsigned , default = 0

**Table 9-1706 VDIN0\_HDR2\_CGAIN\_COEF0 0x12A4**

Bit(s)	R/W	Default	Description
27:16	R/W	0	reg_cgain_coef1 : // unsigned , default = 0
11:0	R/W	0	reg_cgain_coef0 : // unsigned , default = 0

**Table 9-1707 VDIN0\_HDR2\_CGAIN\_COEF1 0x12A5**

Bit(s)	R/W	Default	Description
11:0	R/W	0	reg_cgain_coef2 : // unsigned , default = 0

**Table 9-1708 VDIN0\_OGAIN\_LUT\_ADDR\_PORT 0x12A6**

Bit(s)	R/W	Default	Description
7:0	R/W	0	ogain_lut_addr : // unsigned , default = 0

**Table 9-1709 VDIN0\_OGAIN\_LUT\_DATA\_PORT 0x12A7**

Bit(s)	R/W	Default	Description
11:0	R/W	0	ogain_lut_data : // unsigned , default = 0

**Table 9-1710 VDIN0\_HDR2\_ADPS\_CTRL 0x12A8**

Bit(s)	R/W	Default	Description
6	R/W	1	reg_adpscl_bypass2 : // unsigned , default = 1
5	R/W	1	reg_adpscl_bypass1 : // unsigned , default = 1
4	R/W	1	reg_adpscl_bypass0 : // unsigned , default = 1
1:0	R/W	1	reg_adpscl_mode : // unsigned , default = 1

**Table 9-1711 VDIN0\_HDR2\_ADPS\_ALPHA0 0x12A9**

Bit(s)	R/W	Default	Description
29:16	R/W	0x1000	reg_adpscl_alpha1 : // unsigned , default = 0x1000
13:0	R/W	0x1000	reg_adpscl_alpha0 : // unsigned , default = 0x1000

**Table 9-1712 VDIN0\_HDR2\_ADPS\_ALPHA1 0x12AA**

Bit(s)	R/W	Default	Description
27:24	R/W	0xc	reg_adpscl_shift0 : // unsigned , default = 0xc
23:20	R/W	0xc	reg_adpscl_shift1 : // unsigned , default = 0xc
19:16	R/W	0xc	reg_adpscl_shift2 : // unsigned , default = 0xc
13:0	R/W	0x1000	reg_adpscl_alpha2 : // unsigned , default = 0x1000

**Table 9-1713 VDIN0\_HDR2\_ADPS\_BETA0 0x12AB**

Bit(s)	R/W	Default	Description
20	R/W	0	reg_adpscl_beta0_s : // unsigned , default = 0
19:0	R/W	0xfc000	reg_adpscl_beta0 : // unsigned , default = 0xfc000

**Table 9-1714 VDIN0\_HDR2\_ADPS\_BETA1 0x12AC**

Bit(s)	R/W	Default	Description
20	R/W	0	reg_adpscl_beta1_s : // unsigned , default = 0
19:0	R/W	0xfc000	reg_adpscl_beta1 : // unsigned , default = 0xfc000

**Table 9-1715 VDIN0\_HDR2\_ADPS\_BETA2 0x12AD**

Bit(s)	R/W	Default	Description
20	R/W	0	reg_adpscl_beta2_s : // unsigned , default = 0
19:0	R/W	0xfc000	reg_adpscl_beta2 : // unsigned , default = 0xfc000

**Table 9-1716 VDIN0\_HDR2\_ADPS\_COEF0 0x12AE**

Bit(s)	R/W	Default	Description
27:16	R/W	460	reg_adpscl_ys_coef1 : // unsigned , default = 460
11:0	R/W	1188	reg_adpscl_ys_coef0 : // unsigned , default = 1188

**Table 9-1717 VDIN0\_HDR2\_ADPS\_COEF1 0x12AF**

Bit(s)	R/W	Default	Description
11:0	R/W	104	reg_adpscl_ys_coef2 : // unsigned , default = 104

**Table 9-1718 VDIN0\_HDR2\_GMUT\_CTRL 0x12B0**

Bit(s)	R/W	Default	Description
3:0	R/W	14	reg_gmut_shift : // unsigned , default = 14

**Table 9-1719 VDIN0\_HDR2\_GMUT\_COEF0 0x12B1**

Bit(s)	R/W	Default	Description
31:16	R/W	674	reg_gmut_coef01 : // unsigned , default = 674
15:0	R/W	1285	reg_gmut_coef00 : // unsigned , default = 1285

**Table 9-1720 VDIN0\_HDR2\_GMUT\_COEF1 0x12B2**

Bit(s)	R/W	Default	Description
31:16	R/W	142	reg_gmut_coef10 : // unsigned , default = 142
15:0	R/W	89	reg_gmut_coef02 : // unsigned , default = 89

**Table 9-1721 VDIN0\_HDR2\_GMUT\_COEF2 0x12B3**

Bit(s)	R/W	Default	Description
31:16	R/W	23	reg_gmut_coef12 : // unsigned , default = 23
15:0	R/W	1883	reg_gmut_coef11 : // unsigned , default = 1883

**Table 9-1722 VDIN0\_HDR2\_GMUT\_COEF3 0x12B4**

Bit(s)	R/W	Default	Description
31:16	R/W	180	reg_gmut_coef21 : // unsigned , default = 180
15:0	R/W	34	reg_gmut_coef20 : // unsigned , default = 34

**Table 9-1723 VDIN0\_HDR2\_GMUT\_COEF4 0x12B5**

Bit(s)	R/W	Default	Description
15:0	R/W	1834	reg_gmut_coef22 : // unsigned , default = 1834

**Table 9-1724 VDIN0\_HDR2\_PIPE\_CTRL1 0x12B6**

Bit(s)	R/W	Default	Description
31:24	R/W	4	vblank_num_oetf : // unsigned , default = 4
23:16	R/W	4	hblank_num_oetf : // unsigned , default = 4
15:8	R/W	10	vblank_num_eotf : // unsigned , default = 10
7:0	R/W	10	hblank_num_eotf : // unsigned , default = 10

**Table 9-1725 VDIN0\_HDR2\_PIPE\_CTRL2 0x12B7**

Bit(s)	R/W	Default	Description
31:24	R/W	10	vblank_num_cgain : // unsigned , default = 10
23:16	R/W	10	hblank_num_cgain : // unsigned , default = 10
15:8	R/W	11	vblank_num_gmut : // unsigned , default = 11
7:0	R/W	11	hblank_num_gmut : // unsigned , default = 11

**Table 9-1726 VDIN0\_HDR2\_PIPE\_CTRL3 0x12B8**

Bit(s)	R/W	Default	Description
31:24	R/W	22	vblank_num_adps : // unsigned , default = 22
23:16	R/W	2	hblank_num_adps : // unsigned , default = 2
15:8	R/W	4	vblank_num_uv : // unsigned , default = 4
7:0	R/W	4	hblank_num_uv : // unsigned , default = 4

**Table 9-1727 VDIN0\_HDR2\_PROC\_WIN1 0x12B9**

Bit(s)	R/W	Default	Description
28:16	R/W	0	proc_win_h_ed : // unsigned , default = 0
12:0	R/W	0	proc_win_h_st : // unsigned , default = 0

**Table 9-1728 VDIN0\_HDR2\_PROC\_WIN2 0x12BA**

Bit(s)	R/W	Default	Description
31	R/W	0	proc_win_gmut_en : // unsigned , default = 0
30	R/W	0	proc_win_adps_en : // unsigned , default = 0
29	R/W	0	proc_win_cgain_en : // unsigned , default = 0
28:16	R/W	0	proc_win_v_ed : // unsigned , default = 0
12:0	R/W	0	proc_win_v_st : // unsigned , default = 0

**Table 9-1729 VDIN0\_HDR2\_MATRIXI\_EN\_CTRL 0x12BB**

Bit(s)	R/W	Default	Description
5:4	R/W	0	matrix_gclk_ctrl : // unsigned , default = 0
1	R/W	0	enable_sync_sel : // unsigned , default = 0
0	R/W	0	matrix_conv_en : // unsigned , default = 0

**Table 9-1730 VDIN0\_HDR2\_MATRIXO\_EN\_CTRL 0x12BC**

Bit(s)	R/W	Default	Description
5:4	R/W	0	matrix_gclk_ctrl : // unsigned , default = 0
1	R/W	0	enable_sync_sel : // unsigned , default = 0
0	R/W	0	matrix_conv_en : // unsigned , default = 0

**Table 9-1731 VDIN1\_HDR2\_CTRL 0x1380**

Bit(s)	R/W	Default	Description
20:18	R/W	0	reg_din_swap : // unsigned , default = 0
17	R/W	0	reg_out_fmt : // unsigned , default = 0
16	R/W	0	reg_only_mat : // unsigned , default = 0 ,only use input matrix ,work when hdr disable
15	R/W	0	mat_o_en, //output matrix enable ,only work when hdr enable
14	R/W	0	mat_in_en //input matrix enable ,only work when hdr enable
13	R/W	0	reg_VDIN0_HDR2_top_en : // unsigned , default = 0, hdr enable singal
12	R/W	1	reg_cgain_mode : // unsigned , default = 1
7: 6	R/W	1	reg_gmut_mode : // unsigned , default = 1
5	R/W	0	reg_in_shift : // unsigned , default = 0
4	R/W	1	reg_in_fmt : // unsigned , default = 1
3	R/W	1	reg_eo_enable : // unsigned , default = 1
2	R/W	1	reg_oe_enable : // unsigned , default = 1

**Table 9-1732 VDIN1\_HDR2\_CLK\_GATE 0x1381**

Bit(s)	R/W	Default	Description
31:30	R/W	0	clk_tm : gate clock ctrl (main clock) // unsigned , default = 0
29:28	R/W	0	output : matrix clock gate ctrl // unsigned , default = 0
25:24	R/W	0	input : matrix clock gate ctrl // unsigned , default = 0
23:22	R/W	0	hdr : top cbus clock gate ctrl // unsigned , default = 0
21:20	R/W	0	eotf : cbus clock gate ctrl // unsigned , default = 0
19:18	R/W	0	oetf : cbus clock gate ctrl // unsigned , default = 0
17:16	R/W	0	gamma : mult cbus clock gate ctrl // unsigned , default = 0
15:14	R/W	0	adaptive : cbus scaler clock gate ctrl // unsigned , default = 0
13:12	R/W	0	cgain : cbus clock gate ctrl // unsigned , default = 0
11:10	R/W	0	eotf : clock gate ctrl // unsigned , default = 0
9:8	R/W	0	oetf : clock gate ctrl // unsigned , default = 0
7:6	R/W	0	gamma : mult clock gate ctrl // unsigned , default = 0
5:4	R/W	0	adaptive : scaler clock gate ctrl // unsigned , default = 0



Bit(s)	R/W	Default	Description
3:2	R/W	0	uv : gain clock gate ctrl // unsigned , default = 0
1:0	R/W	0	cgain : clock gate ctrl // unsigned , default = 0

Table 9-1733 VDIN1\_HDR2\_MATRIXI\_COEF00\_01 0x1382

Bit(s)	R/W	Default	Description
28:16	R/W	0	coef00 : // signed , default = 0
12:0	R/W	0	coef01 : // signed , default = 0

Table 9-1734 VDIN1\_HDR2\_MATRIXI\_COEF02\_10 0x1383

Bit(s)	R/W	Default	Description
28:16	R/W	0	coef02 : // signed , default = 0
12:0	R/W	0	coef10 : // signed , default = 0

Table 9-1735 VDIN1\_HDR2\_MATRIXI\_COEF11\_12 0x1384

Bit(s)	R/W	Default	Description
28:16	R/W	0	coef11 : // signed , default = 0
12:0	R/W	0	coef12 : // signed , default = 0

Table 9-1736 VDIN1\_HDR2\_MATRIXI\_COEF20\_21 0x1385

Bit(s)	R/W	Default	Description
28:16	R/W	0	coef20 : // signed , default = 0
12:0	R/W	0	coef21 : // signed , default = 0

Table 9-1737 VDIN1\_HDR2\_MATRIXI\_COEF22 0x1386

Bit(s)	R/W	Default	Description
12:0	R/W	0	coef22 : // signed , default = 0

Table 9-1738 VDIN1\_HDR2\_MATRIXI\_COEF30\_31 0x1387

Bit(s)	R/W	Default	Description
28:16	R/W	0	coef13 : // signed , default = 0
12:0	R/W	0	coef14 : // signed , default = 0

**Table 9-1739 VDIN1\_HDR2\_MATRIXI\_COEF32\_40 0x1388**

Bit(s)	R/W	Default	Description
28:16	R/W	0	coef23 : // signed , default = 0
12:0	R/W	0	coef24 : // signed , default = 0

**Table 9-1740 VDIN1\_HDR2\_MATRIXI\_COEF41\_42 0x1389**

Bit(s)	R/W	Default	Description
28:16	R/W	0	coef15 : // signed , default = 0
12:0	R/W	0	coef25 : // signed , default = 0

**Table 9-1741 VDIN1\_HDR2\_MATRIXI\_OFFSET0\_1 0x138A**

Bit(s)	R/W	Default	Description
26:16	R/W	0	offset0 : // signed , default = 0
10:0	R/W	0	offset1 : // signed , default = 0

**Table 9-1742 VDIN1\_HDR2\_MATRIXI\_OFFSET2 0x138B**

Bit(s)	R/W	Default	Description
10:0	R/W	0	offset2 : // signed , default = 0

**Table 9-1743 VDIN1\_HDR2\_MATRIXI\_PRE\_OFFSET0\_1 0x138C**

Bit(s)	R/W	Default	Description
26:16	R/W	0	pre_offset0 : // signed , default = 0
10:0	R/W	0	pre_offset1 : // signed , default = 0

**Table 9-1744 VDIN1\_HDR2\_MATRIXI\_PRE\_OFFSET2 0x138D**

Bit(s)	R/W	Default	Description
10:0	R/W	0	pre_offset2 : // signed , default = 0

**Table 9-1745 VDIN1\_HDR2\_MATRIXO\_COEF00\_01 0x138E**

Bit(s)	R/W	Default	Description
28:16	R/W	0	coef00 : // signed , default = 0
12:0	R/W	0	coef01 : // signed , default = 0

**Table 9-1746 VDIN1\_HDR2\_MATRIXO\_COEF02\_10 0x138F**

Bit(s)	R/W	Default	Description
28:16	R/W	0	coef02 : // signed , default = 0
12:0	R/W	0	coef10 : // signed , default = 0

**Table 9-1747 VDIN1\_HDR2\_MATRIXO\_COEF11\_12 0x1390**

Bit(s)	R/W	Default	Description
28:16	R/W	0	coef11 : // signed , default = 0
12:0	R/W	0	coef12 : // signed , default = 0

**Table 9-1748 VDIN1\_HDR2\_MATRIXO\_COEF20\_21 0x1391**

Bit(s)	R/W	Default	Description
28:16	R/W	0	coef20 : // signed , default = 0
12:0	R/W	0	coef21 : // signed , default = 0

**Table 9-1749 VDIN1\_HDR2\_MATRIXO\_COEF22 0x1392**

Bit(s)	R/W	Default	Description
12:0	R/W	0	coef22 : // signed , default = 0

**Table 9-1750 VDIN1\_HDR2\_MATRIXO\_COEF30\_31 0x1393**

Bit(s)	R/W	Default	Description
28:16	R/W	0	coef13 : // signed , default = 0
12:0	R/W	0	coef14 : // signed , default = 0

**Table 9-1751 VDIN1\_HDR2\_MATRIXO\_COEF32\_40 0x1394**

Bit(s)	R/W	Default	Description
28:16	R/W	0	coef23 : // signed , default = 0
12:0	R/W	0	coef24 : // signed , default = 0

**Table 9-1752 VDIN1\_HDR2\_MATRIXO\_COEF41\_42 0x1395**

Bit(s)	R/W	Default	Description
28:16	R/W	0	coef15 : // signed , default = 0
12:0	R/W	0	coef25 : // signed , default = 0

**Table 9-1753 VDIN1\_HDR2\_MATRIXO\_OFFSET0\_1 0x1396**

Bit(s)	R/W	Default	Description
26:16	R/W	0	offset0 : // signed , default = 0
10:0	R/W	0	offset1 : // signed , default = 0

**Table 9-1754 VDIN1\_HDR2\_MATRIXO\_OFFSET2 0x1397**

Bit(s)	R/W	Default	Description
10:0	R/W	0	offset2 : // signed , default = 0

**Table 9-1755 VDIN1\_HDR2\_MATRIXO\_PRE\_OFFSET0\_1 0x1398**

Bit(s)	R/W	Default	Description
26:16	R/W	0	pre_offset0 : // signed , default = 0
10:0	R/W	0	pre_offset1 : // signed , default = 0

**Table 9-1756 VDIN1\_HDR2\_MATRIXO\_PRE\_OFFSET2 0x1399**

Bit(s)	R/W	Default	Description
10:0	R/W	0	pre_offset2 : // signed , default = 0

**Table 9-1757 VDIN1\_HDR2\_MATRIXI\_CLIP 0x139A**

Bit(s)	R/W	Default	Description
19:8	R/W	0	comp_th : // unsigned , default = 0
7:5	R/W	0	conv_rs : // unsigned , default = 0
4:3	R/W	0	clmod : // unsigned , default = 0

**Table 9-1758 VDIN1\_HDR2\_MATRIXO\_CLIP 0x139B**

Bit(s)	R/W	Default	Description
19:8	R/W	0	comp_th : // unsigned , default = 0
7:5	R/W	0	conv_rs : // unsigned , default = 0
4:3	R/W	0	clmod : // unsigned , default = 0

**Table 9-1759 VDIN1\_HDR2\_CGAIN\_OFFT 0x139C**

Bit(s)	R/W	Default	Description
26:16	R/W	0	reg_cgain_offt2 : // signed , default = 0
10:0	R/W	0	reg_cgain_offt1 : // signed , default = 0

**Table 9-1760 VDIN1\_EOTF\_LUT\_ADDR\_PORT 0x139E**

Bit(s)	R/W	Default	Description
7:0	R/W	0	eotf_lut_addr : // unsigned , default = 0

**Table 9-1761 VDIN1\_EOTF\_LUT\_DATA\_PORT 0x139F**

Bit(s)	R/W	Default	Description
19:0	R/W	0	eotf_lut_data : // unsigned , default = 0

**Table 9-1762 VDIN1\_OETF\_LUT\_ADDR\_PORT 0x13A0**

Bit(s)	R/W	Default	Description
7:0	R/W	0	oetf_lut_addr : // unsigned , default = 0

**Table 9-1763 VDIN1\_OETF\_LUT\_DATA\_PORT 0x13A1**

Bit(s)	R/W	Default	Description
11:0	R/W	0	oetf_lut_data : // unsigned , default = 0

**Table 9-1764 VDIN1\_CGAIN\_LUT\_ADDR\_PORT 0x13A2**

Bit(s)	R/W	Default	Description
7:0	R/W	0	cgain_lut_addr : // unsigned , default = 0

**Table 9-1765 VDIN1\_CGAIN\_LUT\_DATA\_PORT 0x13A3**

Bit(s)	R/W	Default	Description
11:0	R/W	0	cgain_lut_data : // unsigned , default = 0

**Table 9-1766 VDIN1\_HDR2\_CGAIN\_COEF0 0x13A4**

Bit(s)	R/W	Default	Description
27:16	R/W	0	reg_cgain_coef1 : // unsigned , default = 0
11:0	R/W	0	reg_cgain_coef0 : // unsigned , default = 0

**Table 9-1767 VDIN1\_HDR2\_CGAIN\_COEF1 0x13A5**

Bit(s)	R/W	Default	Description
11:0	R/W	0	reg_cgain_coef2 : // unsigned , default = 0

**Table 9-1768 VDIN1\_OGAIN\_LUT\_ADDR\_PORT 0x13A6**

Bit(s)	R/W	Default	Description
7:0	R/W	0	ogain_lut_addr : // unsigned , default = 0

**Table 9-1769 VDIN1\_OGAIN\_LUT\_DATA\_PORT 0x13A7**

Bit(s)	R/W	Default	Description
11:0	R/W	0	ogain_lut_data : // unsigned , default = 0

**Table 9-1770 VDIN1\_HDR2\_ADPS\_CTRL 0x13A8**

Bit(s)	R/W	Default	Description
6	R/W	1	reg_adpscl_bypass2 : // unsigned , default = 1
5	R/W	1	reg_adpscl_bypass1 : // unsigned , default = 1
4	R/W	1	reg_adpscl_bypass0 : // unsigned , default = 1
1:0	R/W	1	reg_adpscl_mode : // unsigned , default = 1

**Table 9-1771 VDIN1\_HDR2\_ADPS\_ALPHA0 0x13A9**

Bit(s)	R/W	Default	Description
29:16	R/W	0x1000	reg_adpscl_alpha1 : // unsigned , default = 0x1000
13:0	R/W	0x1000	reg_adpscl_alpha0 : // unsigned , default = 0x1000

**Table 9-1772 VDIN1\_HDR2\_ADPS\_ALPHA1 0x13AA**

Bit(s)	R/W	Default	Description
27:24	R/W	0xc	reg_adpscl_shift0 : // unsigned , default = 0xc
23:20	R/W	0xc	reg_adpscl_shift1 : // unsigned , default = 0xc
19:16	R/W	0xc	reg_adpscl_shift2 : // unsigned , default = 0xc
13:0	R/W	0x1000	reg_adpscl_alpha2 : // unsigned , default = 0x1000

**Table 9-1773 VDIN1\_HDR2\_ADPS\_BETA0 0x13AB**

Bit(s)	R/W	Default	Description
20	R/W	0	reg_adpscl_beta0_s : // unsigned , default = 0
19:0	R/W	0xfc000	reg_adpscl_beta0 : // unsigned , default = 0xfc000

**Table 9-1774 VDIN1\_HDR2\_ADPS\_BETA1 0x13AC**

Bit(s)	R/W	Default	Description
20	R/W	0	reg_adpscl_beta1_s : // unsigned , default = 0
19:0	R/W	0xfc000	reg_adpscl_beta1 : // unsigned , default = 0xfc000

**Table 9-1775 VDIN1\_HDR2\_ADPS\_BETA2 0x13AD**

Bit(s)	R/W	Default	Description
20	R/W	0	reg_adpscl_beta2_s : // unsigned , default = 0
19:0	R/W	0xfc000	reg_adpscl_beta2 : // unsigned , default = 0xfc000

**Table 9-1776 VDIN1\_HDR2\_ADPS\_COEF0 0x13AE**

Bit(s)	R/W	Default	Description
27:16	R/W	460	reg_adpscl_ys_coef1 : // unsigned , default = 460
11:0	R/W	1188	reg_adpscl_ys_coef0 : // unsigned , default = 1188

**Table 9-1777 VDIN1\_HDR2\_ADPS\_COEF1 0x13AF**

Bit(s)	R/W	Default	Description
11:0	R/W	104	reg_adpscl_ys_coef2 : // unsigned , default = 104

**Table 9-1778 VDIN1\_HDR2\_GMUT\_CTRL 0x13B0**

Bit(s)	R/W	Default	Description
3:0	R/W	14	reg_gmut_shift : // unsigned , default = 14

**Table 9-1779 VDIN1\_HDR2\_GMUT\_COEF0 0x13B1**

Bit(s)	R/W	Default	Description
31:16	R/W	674	reg_gmut_coef01 : // unsigned , default = 674
15:0	R/W	1285	reg_gmut_coef00 : // unsigned , default = 1285

**Table 9-1780 VDIN1\_HDR2\_GMUT\_COEF1 0x13B2**

Bit(s)	R/W	Default	Description
31:16	R/W	142	reg_gmut_coef10 : // unsigned , default = 142
15:0	R/W	89	reg_gmut_coef02 : // unsigned , default = 89

**Table 9-1781 VDIN1\_HDR2\_GMUT\_COEF2 0x13B3**

Bit(s)	R/W	Default	Description
31:16	R/W	23	reg_gmut_coef12 : // unsigned , default = 23
15:0	R/W	1883	reg_gmut_coef11 : // unsigned , default = 1883

**Table 9-1782 VDIN1\_HDR2\_GMUT\_COEF3 0x13B4**

Bit(s)	R/W	Default	Description
31:16	R/W	180	reg_gmut_coef21 : // unsigned , default = 180
15:0	R/W	34	reg_gmut_coef20 : // unsigned , default = 34

**Table 9-1783 VDIN1\_HDR2\_GMUT\_COEF4 0x13B5**

Bit(s)	R/W	Default	Description
15:0	R/W	1834	reg_gmut_coef22 : // unsigned , default = 1834

**Table 9-1784 VDIN1\_HDR2\_PIPE\_CTRL1 0x13B6**

Bit(s)	R/W	Default	Description
31:24	R/W	4	vblank_num_oetf : // unsigned , default = 4
23:16	R/W	4	hblank_num_oetf : // unsigned , default = 4
15:8	R/W	10	vblank_num_eotf : // unsigned , default = 10
7:0	R/W	10	hblank_num_eotf : // unsigned , default = 10

**Table 9-1785 VDIN1\_HDR2\_PIPE\_CTRL2 0x13B7**

Bit(s)	R/W	Default	Description
31:24	R/W	10	vblank_num_cgain : // unsigned , default = 10
23:16	R/W	10	hblank_num_cgain : // unsigned , default = 10
15:8	R/W	11	vblank_num_gmut : // unsigned , default = 11
7:0	R/W	11	hblank_num_gmut : // unsigned , default = 11

**Table 9-1786 VDIN1\_HDR2\_PIPE\_CTRL3 0x13B8**

Bit(s)	R/W	Default	Description
31:24	R/W	22	vblank_num_adps : // unsigned , default = 22
23:16	R/W	2	hblank_num_adps : // unsigned , default = 2
15:8	R/W	4	vblank_num_uv : // unsigned , default = 4
7:0	R/W	4	hblank_num_uv : // unsigned , default = 4



**Table 9-1787 VDIN1\_HDR2\_PROC\_WIN1 0x13B9**

Bit(s)	R/W	Default	Description
28:16	R/W	0	proc_win_h_ed : // unsigned , default = 0
12:0	R/W	0	proc_win_h_st : // unsigned , default = 0

**Table 9-1788 VDIN1\_HDR2\_PROC\_WIN2 0x13BA**

Bit(s)	R/W	Default	Description
31	R/W	0	proc_win_gmut_en : // unsigned , default = 0
30	R/W	0	proc_win_adps_en : // unsigned , default = 0
29	R/W	0	proc_win_cgain_en : // unsigned , default = 0
28:16	R/W	0	proc_win_v_ed : // unsigned , default = 0
12:0	R/W	0	proc_win_v_st : // unsigned , default = 0

**Table 9-1789 VDIN1\_HDR2\_MATRIXI\_EN\_CTRL 0x13BB**

Bit(s)	R/W	Default	Description
5:4	R/W	0	matrix_gclk_ctrl : // unsigned , default = 0
1	R/W	0	enable_sync_sel : // unsigned , default = 0
0	R/W	0	matrix_conv_en : // unsigned , default = 0

**Table 9-1790 VDIN1\_HDR2\_MATRIXO\_EN\_CTRL 0x13BC**

Bit(s)	R/W	Default	Description
5:4	R/W	0	matrix_gclk_ctrl : // unsigned , default = 0
1	R/W	0	enable_sync_sel : // unsigned , default = 0
0	R/W	0	matrix_conv_en : // unsigned , default = 0

**Table 9-1791 VD1\_HDR2\_CTRL 0x3800**

Bit(s)	R/W	Default	Description
20:18	R/W	0	reg_din_swap : // unsigned , default = 0
17	R/W	0	reg_out_fmt : // unsigned , default = 0
16	R/W	0	reg_only_mat : // unsigned , default = 0 ,only use input matrix ,work when hdr disable
15	R/W	0	mat_o_en, //output matrix enable ,only work when hdr enable
14	R/W	0	mat_in_en //input matrix enable ,only work when hdr enable
13	R/W	0	reg_VDIN0_HDR2_top_en : // unsigned , default = 0, hdr enable singal
12	R/W	1	reg_cgain_mode : // unsigned , default = 1
7: 6	R/W	1	reg_gmut_mode : // unsigned , default = 1

Bit(s)	R/W	Default	Description
5	R/W	0	reg_in_shift : // unsigned , default = 0
4	R/W	1	reg_in_fmt : // unsigned , default = 1
3	R/W	1	reg_eo_enable : // unsigned , default = 1
2	R/W	1	reg_oe_enable : // unsigned , default = 1

Table 9-1792 VD1\_HDR2\_CLK\_GATE 0x3801

Bit(s)	R/W	Default	Description
31:30	R/W	0	clk_tm : gate clock ctrl (main clock) // unsigned , default = 0
29:28	R/W	0	output : matrix clock gate ctrl// unsigned , default = 0
25:24	R/W	0	input : matrix clock gate ctrl // unsigned , default = 0
23:22	R/W	0	hdr : top cbus clock gate ctrl // unsigned , default = 0
21:20	R/W	0	eotf : cbus clock gate ctrl // unsigned , default = 0
19:18	R/W	0	oetf : cbus clock gate ctrl // unsigned , default = 0
17:16	R/W	0	gamma : mult cbus clock gate ctrl // unsigned , default = 0
15:14	R/W	0	adaptive : cbus scaler clock gate ctrl // unsigned , default = 0
13:12	R/W	0	cgain : cbus clock gate ctrl// unsigned , default = 0
11:10	R/W	0	eotf : clock gate ctrl // unsigned , default = 0
9:8	R/W	0	oetf : clock gate ctrl // unsigned , default = 0
7:6	R/W	0	gamma : mult clock gate ctrl// unsigned , default = 0
5:4	R/W	0	adaptive : scaler clock gate ctrl // unsigned , default = 0
3:2	R/W	0	uv : gain clock gate ctrl // unsigned , default = 0
1:0	R/W	0	cgain : clock gate ctrl // unsigned , default = 0

Table 9-1793 VD1\_HDR2\_MATRIXI\_COEF00\_01 0x3802

Bit(s)	R/W	Default	Description
28:16	R/W	0	coef00 : // signed , default = 0
12:0	R/W	0	coef01 : // signed , default = 0

Table 9-1794 VD1\_HDR2\_MATRIXI\_COEF02\_10 0x3803

Bit(s)	R/W	Default	Description
28:16	R/W	0	coef02 : // signed , default = 0
12:0	R/W	0	coef10 : // signed , default = 0

**Table 9-1795 VD1\_HDR2\_MATRIXI\_COEF11\_12 0x3804**

Bit(s)	R/W	Default	Description
28:16	R/W	0	coef11 : // signed , default = 0
12:0	R/W	0	coef12 : // signed , default = 0

**Table 9-1796 VD1\_HDR2\_MATRIXI\_COEF20\_21 0x3805**

Bit(s)	R/W	Default	Description
28:16	R/W	0	coef20 : // signed , default = 0
12:0	R/W	0	coef21 : // signed , default = 0

**Table 9-1797 VD1\_HDR2\_MATRIXI\_COEF22 0x3806**

Bit(s)	R/W	Default	Description
12:0	R/W	0	coef22 : // signed , default = 0

**Table 9-1798 VD1\_HDR2\_MATRIXI\_COEF30\_31 0x3807**

Bit(s)	R/W	Default	Description
28:16	R/W	0	coef13 : // signed , default = 0
12:0	R/W	0	coef14 : // signed , default = 0

**Table 9-1799 VD1\_HDR2\_MATRIXI\_COEF32\_40 0x3808**

Bit(s)	R/W	Default	Description
28:16	R/W	0	coef23 : // signed , default = 0
12:0	R/W	0	coef24 : // signed , default = 0

**Table 9-1800 VD1\_HDR2\_MATRIXI\_COEF41\_42 0x3809**

Bit(s)	R/W	Default	Description
28:16	R/W	0	coef15 : // signed , default = 0
12:0	R/W	0	coef25 : // signed , default = 0

**Table 9-1801 VD1\_HDR2\_MATRIXI\_OFFSET0\_1 0x380A**

Bit(s)	R/W	Default	Description
26:16	R/W	0	offset0 : // signed , default = 0
10:0	R/W	0	offset1 : // signed , default = 0

**Table 9-1802 VD1\_HDR2\_MATRIXI\_OFFSET2 0x380B**

Bit(s)	R/W	Default	Description
10:0	R/W	0	offset2 : // signed , default = 0

**Table 9-1803 VD1\_HDR2\_MATRIXI\_PRE\_OFFSET0\_1 0x380C**

Bit(s)	R/W	Default	Description
26:16	R/W	0	pre_offset0 : // signed , default = 0
10:0	R/W	0	pre_offset1 : // signed , default = 0

**Table 9-1804 VD1\_HDR2\_MATRIXI\_PRE\_OFFSET2 0x380D**

Bit(s)	R/W	Default	Description
10:0	R/W	0	pre_offset2 : // signed , default = 0

**Table 9-1805 VD1\_HDR2\_MATRIXO\_COEF00\_01 0x380E**

Bit(s)	R/W	Default	Description
28:16	R/W	0	coef00 : // signed , default = 0
12:0	R/W	0	coef01 : // signed , default = 0

**Table 9-1806 VD1\_HDR2\_MATRIXO\_COEF02\_10 0x380F**

Bit(s)	R/W	Default	Description
28:16	R/W	0	coef02 : // signed , default = 0
12:0	R/W	0	coef10 : // signed , default = 0

**Table 9-1807 VD1\_HDR2\_MATRIXO\_COEF11\_12 0x3810**

Bit(s)	R/W	Default	Description
28:16	R/W	0	coef11 : // signed , default = 0
12:0	R/W	0	coef12 : // signed , default = 0

**Table 9-1808 VD1\_HDR2\_MATRIXO\_COEF20\_21 0x3811**

Bit(s)	R/W	Default	Description
28:16	R/W	0	coef20 : // signed , default = 0
12:0	R/W	0	coef21 : // signed , default = 0

**Table 9-1809 VD1\_HDR2\_MATRIXO\_COEF22 0x3812**

Bit(s)	R/W	Default	Description
12:0	R/W	0	coef22 : // signed , default = 0

**Table 9-1810 VD1\_HDR2\_MATRIXO\_COEF30\_31 0x3813**

Bit(s)	R/W	Default	Description
28:16	R/W	0	coef13 : // signed , default = 0
12:0	R/W	0	coef14 : // signed , default = 0

**Table 9-1811 VD1\_HDR2\_MATRIXO\_COEF32\_40 0x3814**

Bit(s)	R/W	Default	Description
28:16	R/W	0	coef23 : // signed , default = 0
12:0	R/W	0	coef24 : // signed , default = 0

**Table 9-1812 VD1\_HDR2\_MATRIXO\_COEF41\_42 0x3815**

Bit(s)	R/W	Default	Description
28:16	R/W	0	coef15 : // signed , default = 0
12:0	R/W	0	coef25 : // signed , default = 0

**Table 9-1813 VD1\_HDR2\_MATRIXO\_OFFSET0\_1 0x3816**

Bit(s)	R/W	Default	Description
26:16	R/W	0	offset0 : // signed , default = 0
10:0	R/W	0	offset1 : // signed , default = 0

**Table 9-1814 VD1\_HDR2\_MATRIXO\_OFFSET2 0x3817**

Bit(s)	R/W	Default	Description
10:0	R/W	0	offset2 : // signed , default = 0

**Table 9-1815 VD1\_HDR2\_MATRIXO\_PRE\_OFFSET0\_1 0x3818**

Bit(s)	R/W	Default	Description
26:16	R/W	0	pre_offset0 : // signed , default = 0
10:0	R/W	0	pre_offset1 : // signed , default = 0

**Table 9-1816 VD1\_HDR2\_MATRIXO\_PRE\_OFFSET2 0x3819**

Bit(s)	R/W	Default	Description
10:0	R/W	0	pre_offset2 : // signed , default = 0

**Table 9-1817 VD1\_HDR2\_MATRIXI\_CLIP 0x381A**

Bit(s)	R/W	Default	Description
19:8	R/W	0	comp_th : // unsigned , default = 0
7:5	R/W	0	conv_rs : // unsigned , default = 0
4:3	R/W	0	clmod : // unsigned , default = 0

**Table 9-1818 VD1\_HDR2\_MATRIXO\_CLIP 0x381B**

Bit(s)	R/W	Default	Description
19:8	R/W	0	comp_th : // unsigned , default = 0
7:5	R/W	0	conv_rs : // unsigned , default = 0
4:3	R/W	0	clmod : // unsigned , default = 0

**Table 9-1819 VD1\_HDR2\_CGAIN\_OFFT 0x381C**

Bit(s)	R/W	Default	Description
26:16	R/W	0	reg_cgain_off2 : // signed , default = 0
10:0	R/W	0	reg_cgain_off1 : // signed , default = 0

**Table 9-1820 VD1\_EOTF\_LUT\_ADDR\_PORT 0x381E**

Bit(s)	R/W	Default	Description
7:0	R/W	0	eotf_lut_addr : // unsigned , default = 0

**Table 9-1821 VD1\_EOTF\_LUT\_DATA\_PORT 0x381F**

Bit(s)	R/W	Default	Description
19:0	R/W	0	eotf_lut_data : // unsigned , default = 0

**Table 9-1822 VD1\_OETF\_LUT\_ADDR\_PORT 0x3820**

Bit(s)	R/W	Default	Description
7:0	R/W	0	oetf_lut_addr : // unsigned , default = 0

**Table 9-1823 VD1\_OETF\_LUT\_DATA\_PORT 0x3821**

Bit(s)	R/W	Default	Description
11:0	R/W	0	oetf_lut_data : // unsigned , default = 0

**Table 9-1824 VD1\_CGAIN\_LUT\_ADDR\_PORT 0x3822**

Bit(s)	R/W	Default	Description
7:0	R/W	0	cgain_lut_addr : // unsigned , default = 0

**Table 9-1825 VD1\_CGAIN\_LUT\_DATA\_PORT 0x3823**

Bit(s)	R/W	Default	Description
11:0	R/W	0	cgain_lut_data : // unsigned , default = 0

**Table 9-1826 VD1\_HDR2\_CGAIN\_COEF0 0x3824**

Bit(s)	R/W	Default	Description
27:16	R/W	0	reg_cgain_coef1 : // unsigned , default = 0
11:0	R/W	0	reg_cgain_coef0 : // unsigned , default = 0

**Table 9-1827 VD1\_HDR2\_CGAIN\_COEF1 0x3825**

Bit(s)	R/W	Default	Description
11:0	R/W	0	reg_cgain_coef2 : // unsigned , default = 0

**Table 9-1828 VD1\_OGAIN\_LUT\_ADDR\_PORT 0x3826**

Bit(s)	R/W	Default	Description
7:0	R/W	0	ogain_lut_addr : // unsigned , default = 0

**Table 9-1829 VD1\_OGAIN\_LUT\_DATA\_PORT 0x3827**

Bit(s)	R/W	Default	Description
11:0	R/W	0	ogain_lut_data : // unsigned , default = 0

**Table 9-1830 VD1\_HDR2\_ADPS\_CTRL 0x3828**

Bit(s)	R/W	Default	Description
6	R/W	1	reg_adpscl_bypass2 : // unsigned , default = 1
5	R/W	1	reg_adpscl_bypass1 : // unsigned , default = 1
4	R/W	1	reg_adpscl_bypass0 : // unsigned , default = 1
1:0	R/W	1	reg_adpscl_mode : // unsigned , default = 1

**Table 9-1831 VD1\_HDR2\_ADPS\_ALPHA0 0x3829**

Bit(s)	R/W	Default	Description
29:16	R/W	0x1000	reg_adpscl_alpha1 : // unsigned , default = 0x1000
13:0	R/W	0x1000	reg_adpscl_alpha0 : // unsigned , default = 0x1000

**Table 9-1832 VD1\_HDR2\_ADPS\_ALPHA1 0x382A**

Bit(s)	R/W	Default	Description
27:24	R/W	0xc	reg_adpscl_shift0 : // unsigned , default = 0xc
23:20	R/W	0xc	reg_adpscl_shift1 : // unsigned , default = 0xc
19:16	R/W	0xc	reg_adpscl_shift2 : // unsigned , default = 0xc
13:0	R/W	0x1000	reg_adpscl_alpha2 : // unsigned , default = 0x1000

**Table 9-1833 VD1\_HDR2\_ADPS\_BETA0 0x382B**

Bit(s)	R/W	Default	Description
20	R/W	0	reg_adpscl_beta0_s : // unsigned , default = 0
19:0	R/W	0xfc000	reg_adpscl_beta0 : // unsigned , default = 0xfc000

**Table 9-1834 VD1\_HDR2\_ADPS\_BETA1 0x382C**

Bit(s)	R/W	Default	Description
20	R/W	0	reg_adpscl_beta1_s : // unsigned , default = 0
19:0	R/W	0xfc000	reg_adpscl_beta1 : // unsigned , default = 0xfc000

**Table 9-1835 VD1\_HDR2\_ADPS\_BETA2 0x382D**

Bit(s)	R/W	Default	Description
20	R/W	0	reg_adpscl_beta2_s : // unsigned , default = 0
19:0	R/W	0xfc000	reg_adpscl_beta2 : // unsigned , default = 0xfc000

**Table 9-1836 VD1\_HDR2\_ADPS\_COEF0 0x382E**

Bit(s)	R/W	Default	Description
27:16	R/W	460	reg_adpscl_ys_coef1 : // unsigned , default = 460
11:0	R/W	1188	reg_adpscl_ys_coef0 : // unsigned , default = 1188

**Table 9-1837 VD1\_HDR2\_ADPS\_COEF1 0x382F**

Bit(s)	R/W	Default	Description
11:0	R/W	104	reg_adpscl_ys_coef2 : // unsigned , default = 104



**Table 9-1838 VD1\_HDR2\_GMUT\_CTRL 0x3830**

Bit(s)	R/W	Default	Description
3:0	R/W	14	reg_gmut_shift : // unsigned , default = 14

**Table 9-1839 VD1\_HDR2\_GMUT\_COEF0 0x3831**

Bit(s)	R/W	Default	Description
31:16	R/W	674	reg_gmut_coef01 : // unsigned , default = 674
15:0	R/W	1285	reg_gmut_coef00 : // unsigned , default = 1285

**Table 9-1840 VD1\_HDR2\_GMUT\_COEF1 0x3832**

Bit(s)	R/W	Default	Description
31:16	R/W	142	reg_gmut_coef10 : // unsigned , default = 142
15:0	R/W	89	reg_gmut_coef02 : // unsigned , default = 89

**Table 9-1841 VD1\_HDR2\_GMUT\_COEF2 0x3833**

Bit(s)	R/W	Default	Description
31:16	R/W	23	reg_gmut_coef12 : // unsigned , default = 23
15:0	R/W	1883	reg_gmut_coef11 : // unsigned , default = 1883

**Table 9-1842 VD1\_HDR2\_GMUT\_COEF3 0x3834**

Bit(s)	R/W	Default	Description
31:16	R/W	180	reg_gmut_coef21 : // unsigned , default = 180
15:0	R/W	34	reg_gmut_coef20 : // unsigned , default = 34

**Table 9-1843 VD1\_HDR2\_GMUT\_COEF4 0x3835**

Bit(s)	R/W	Default	Description
15:0	R/W	1834	reg_gmut_coef22 : // unsigned , default = 1834

**Table 9-1844 VD1\_HDR2\_PIPE\_CTRL1 0x3836**

Bit(s)	R/W	Default	Description
31:24	R/W	4	vblank_num_oetf : // unsigned , default = 4
23:16	R/W	4	hblank_num_oetf : // unsigned , default = 4
15:8	R/W	10	vblank_num_eotf : // unsigned , default = 10
7:0	R/W	10	hblank_num_eotf : // unsigned , default = 10

**Table 9-1845 VD1\_HDR2\_PIPE\_CTRL2 0x3837**

Bit(s)	R/W	Default	Description
31:24	R/W	10	vblank_num_cgain : // unsigned , default = 10
23:16	R/W	10	hblank_num_cgain : // unsigned , default = 10
15:8	R/W	11	vblank_num_gmut : // unsigned , default = 11
7:0	R/W	11	hblank_num_gmut : // unsigned , default = 11

**Table 9-1846 VD1\_HDR2\_PIPE\_CTRL3 0x3838**

Bit(s)	R/W	Default	Description
31:24	R/W	22	vblank_num_adps : // unsigned , default = 22
23:16	R/W	2	hblank_num_adps : // unsigned , default = 2
15:8	R/W	4	vblank_num_uv : // unsigned , default = 4
7:0	R/W	4	hblank_num_uv : // unsigned , default = 4

**Table 9-1847 VD1\_HDR2\_PROC\_WIN1 0x3839**

Bit(s)	R/W	Default	Description
28:16	R/W	0	proc_win_h_ed : // unsigned , default = 0
12:0	R/W	0	proc_win_h_st : // unsigned , default = 0

**Table 9-1848 VD1\_HDR2\_PROC\_WIN2 0x383A**

Bit(s)	R/W	Default	Description
31	R/W	0	proc_win_gmut_en : // unsigned , default = 0
30	R/W	0	proc_win_adps_en : // unsigned , default = 0
29	R/W	0	proc_win_cgain_en : // unsigned , default = 0
28:16	R/W	0	proc_win_v_ed : // unsigned , default = 0
12:0	R/W	0	proc_win_v_st : // unsigned , default = 0

**Table 9-1849 VD1\_HDR2\_MATRIXI\_EN\_CTRL 0x383B**

Bit(s)	R/W	Default	Description
5:4	R/W	0	matrix_gclk_ctrl : // unsigned , default = 0
1	R/W	0	enable_sync_sel : // unsigned , default = 0
0	R/W	0	matrix_conv_en : // unsigned , default = 0

**Table 9-1850 VD1\_HDR2\_MATRIXO\_EN\_CTRL 0x383C**

Bit(s)	R/W	Default	Description
5:4	R/W	0	matrix_gclk_ctrl : // unsigned , default = 0
1	R/W	0	enable_sync_sel : // unsigned , default = 0
0	R/W	0	matrix_conv_en : // unsigned , default = 0

**Table 9-1851 VD1\_HDR2\_MATRIXI\_EN\_CTRL 0x383B**

Bit(s)	R/W	Default	Description
5:4	R/W	0	matrix_gclk_ctrl : // unsigned , default = 0
1	R/W	0	enable_sync_sel : // unsigned , default = 0
0	R/W	0	matrix_conv_en : // unsigned , default = 0

**Table 9-1852 VD1\_HDR2\_HIST\_CTRL 0x383c**

Bit(s)	R/W	Default	Description
23-16	R/W	0	hist result read index
15-8	R/W	0	gate clock ctrl
5	R/W	0	piecewise mode enable
4	R/W	0	hist window enable
3	R/W	0	data shfit enable
2-0	R/W	0	hist input select 0: e_rgb max 1: e_luma 2/3: e_nolier_sat 4/5: o_before_gamma 6/7 : after_gamma

**Table 9-1853 VD2\_HDR2\_CTRL 0x3850**

Bit(s)	R/W	Default	Description
20:18	R/W	0	reg_din_swap : // unsigned , default = 0
17	R/W	0	reg_out_fmt : // unsigned , default = 0
16	R/W	0	reg_only_mat : // unsigned , default = 0 ,only use input matrix ,work when hdr disable
15	R/W	0	mat_o_en, //output matrix enable ,only work when hdr enable
14	R/W	0	mat_in_en //input matrix enable ,only work when hdr enable
13	R/W	0	reg_VDIN0_HDR2_top_en : // unsigned , default = 0, hdr enable singal
12	R/W	1	reg_cgain_mode : // unsigned , default = 1
7: 6	R/W	1	reg_gmut_mode : // unsigned , default = 1
5	R/W	0	reg_in_shift : // unsigned , default = 0
4	R/W	1	reg_in_fmt : // unsigned , default = 1
3	R/W	1	reg_eo_enable : // unsigned , default = 1
2	R/W	1	reg_oe_enable : // unsigned , default = 1

**Table 9-1854 VD2\_HDR2\_CLK\_GATE 0x3851**

Bit(s)	R/W	Default	Description
31:30	R/W	0	clk_tm : gate clock ctrl (main clock) // unsigned , default = 0
29:28	R/W	0	output : matrix clock gate ctrl// unsigned , default = 0
25:24	R/W	0	input : matrix clock gate ctrl // unsigned , default = 0
23:22	R/W	0	hdr : top cbus clock gate ctrl // unsigned , default = 0
21:20	R/W	0	eotf : cbus clock gate ctrl // unsigned , default = 0
19:18	R/W	0	oetf : cbus clock gate ctrl // unsigned , default = 0
17:16	R/W	0	gamma : mult cbus clock gate ctrl // unsigned , default = 0
15:14	R/W	0	adaptive : cbus scaler clock gate ctrl // unsigned , default = 0
13:12	R/W	0	cgain : cbus clock gate ctrl// unsigned , default = 0
11:10	R/W	0	eotf : clock gate ctrl // unsigned , default = 0
9:8	R/W	0	oetf : clock gate ctrl // unsigned , default = 0
7:6	R/W	0	gamma : mult clock gate ctrl// unsigned , default = 0
5:4	R/W	0	adaptive : scaler clock gate ctrl // unsigned , default = 0
3:2	R/W	0	uv : gain clock gate ctrl // unsigned , default = 0
1:0	R/W	0	cgain : clock gate ctrl // unsigned , default = 0

**Table 9-1855 VD2\_HDR2\_MATRIXI\_COEF00\_01 0x3852**

Bit(s)	R/W	Default	Description
28:16	R/W	0	coef00 : // signed , default = 0
12:0	R/W	0	coef01 : // signed , default = 0

**Table 9-1856 VD2\_HDR2\_MATRIXI\_COEF02\_10 0x3853**

Bit(s)	R/W	Default	Description
28:16	R/W	0	coef02 : // signed , default = 0
12:0	R/W	0	coef10 : // signed , default = 0

**Table 9-1857 VD2\_HDR2\_MATRIXI\_COEF11\_12 0x3854**

Bit(s)	R/W	Default	Description
28:16	R/W	0	coef11 : // signed , default = 0
12:0	R/W	0	coef12 : // signed , default = 0

**Table 9-1858 VD2\_HDR2\_MATRIXI\_COEF20\_21 0x3855**

Bit(s)	R/W	Default	Description
28:16	R/W	0	coef20 : // signed , default = 0
12:0	R/W	0	coef21 : // signed , default = 0

**Table 9-1859 VD2\_HDR2\_MATRIXI\_COEF22 0x3856**

Bit(s)	R/W	Default	Description
12:0	R/W	0	coef22 : // signed , default = 0

**Table 9-1860 VD2\_HDR2\_MATRIXI\_COEF30\_31 0x3857**

Bit(s)	R/W	Default	Description
28:16	R/W	0	coef13 : // signed , default = 0
12:0	R/W	0	coef14 : // signed , default = 0

**Table 9-1861 VD2\_HDR2\_MATRIXI\_COEF32\_40 0x3858**

Bit(s)	R/W	Default	Description
28:16	R/W	0	coef23 : // signed , default = 0
12:0	R/W	0	coef24 : // signed , default = 0

**Table 9-1862 VD2\_HDR2\_MATRIXI\_COEF41\_42 0x3859**

Bit(s)	R/W	Default	Description
28:16	R/W	0	coef15 : // signed , default = 0
12:0	R/W	0	coef25 : // signed , default = 0

**Table 9-1863 VD2\_HDR2\_MATRIXI\_OFFSET0\_1 0x385A**

Bit(s)	R/W	Default	Description
26:16	R/W	0	offset0 : // signed , default = 0
10:0	R/W	0	offset1 : // signed , default = 0

**Table 9-1864 VD2\_HDR2\_MATRIXI\_OFFSET2 0x385B**

Bit(s)	R/W	Default	Description
10:0	R/W	0	offset2 : // signed , default = 0

**Table 9-1865 VD2\_HDR2\_MATRIXI\_PRE\_OFFSET0\_1 0x385C**

Bit(s)	R/W	Default	Description
26:16	R/W	0	pre_offset0 : // signed , default = 0
10:0	R/W	0	pre_offset1 : // signed , default = 0

**Table 9-1866 VD2\_HDR2\_MATRIXI\_PRE\_OFFSET2 0x385D**

Bit(s)	R/W	Default	Description
10:0	R/W	0	pre_offset2 : // signed , default = 0

**Table 9-1867 VD2\_HDR2\_MATRIXO\_COEF00\_01 0x385E**

Bit(s)	R/W	Default	Description
28:16	R/W	0	coef00 : // signed , default = 0
12:0	R/W	0	coef01 : // signed , default = 0

**Table 9-1868 VD2\_HDR2\_MATRIXO\_COEF02\_10 0x385F**

Bit(s)	R/W	Default	Description
28:16	R/W	0	coef02 : // signed , default = 0
12:0	R/W	0	coef10 : // signed , default = 0

**Table 9-1869 VD2\_HDR2\_MATRIXO\_COEF11\_12 0x3860**

Bit(s)	R/W	Default	Description
28:16	R/W	0	coef11 : // signed , default = 0
12:0	R/W	0	coef12 : // signed , default = 0

**Table 9-1870 VD2\_HDR2\_MATRIXO\_COEF20\_21 0x3861**

Bit(s)	R/W	Default	Description
28:16	R/W	0	coef20 : // signed , default = 0
12:0	R/W	0	coef21 : // signed , default = 0

**Table 9-1871 VD2\_HDR2\_MATRIXO\_COEF22 0x3862**

Bit(s)	R/W	Default	Description
12:0	R/W	0	coef22 : // signed , default = 0

**Table 9-1872 VD2\_HDR2\_MATRIXO\_COEF30\_31 0x3863**

Bit(s)	R/W	Default	Description
28:16	R/W	0	coef13 : // signed , default = 0
12:0	R/W	0	coef14 : // signed , default = 0

**Table 9-1873 VD2\_HDR2\_MATRIXO\_COEF32\_40 0x3864**

Bit(s)	R/W	Default	Description
28:16	R/W	0	coef23 : // signed , default = 0
12:0	R/W	0	coef24 : // signed , default = 0

**Table 9-1874 VD2\_HDR2\_MATRIXO\_COEF41\_42 0x3865**

Bit(s)	R/W	Default	Description
28:16	R/W	0	coef15 : // signed , default = 0
12:0	R/W	0	coef25 : // signed , default = 0

**Table 9-1875 VD2\_HDR2\_MATRIXO\_OFFSET0\_1 0x3866**

Bit(s)	R/W	Default	Description
26:16	R/W	0	offset0 : // signed , default = 0
10:0	R/W	0	offset1 : // signed , default = 0

**Table 9-1876 VD2\_HDR2\_MATRIXO\_OFFSET2 0x3867**

Bit(s)	R/W	Default	Description
10:0	R/W	0	offset2 : // signed , default = 0

**Table 9-1877 VD2\_HDR2\_MATRIXO\_PRE\_OFFSET0\_1 0x3868**

Bit(s)	R/W	Default	Description
26:16	R/W	0	pre_offset0 : // signed , default = 0
10:0	R/W	0	pre_offset1 : // signed , default = 0

**Table 9-1878 VD2\_HDR2\_MATRIXO\_PRE\_OFFSET2 0x3869**

Bit(s)	R/W	Default	Description
10:0	R/W	0	pre_offset2 : // signed , default = 0

**Table 9-1879 VD2\_HDR2\_MATRIXI\_CLIP 0x386A**

Bit(s)	R/W	Default	Description
19:8	R/W	0	comp_th : // unsigned , default = 0
7:5	R/W	0	conv_rs : // unsigned , default = 0
4:3	R/W	0	clmod : // unsigned , default = 0

**Table 9-1880 VD2\_HDR2\_MATRIXO\_CLIP 0x386B**

Bit(s)	R/W	Default	Description
19:8	R/W	0	comp_th : // unsigned , default = 0
7:5	R/W	0	conv_rs : // unsigned , default = 0
4:3	R/W	0	clmod : // unsigned , default = 0

**Table 9-1881 VD2\_HDR2\_CGAIN\_OFFT 0x386C**

Bit(s)	R/W	Default	Description
26:16	R/W	0	reg_cgain_offt2 : // signed , default = 0
10:0	R/W	0	reg_cgain_offt1 : // signed , default = 0

**Table 9-1882 VD2\_EOTF\_LUT\_ADDR\_PORT 0x386E**

Bit(s)	R/W	Default	Description
7:0	R/W	0	eotf_lut_addr : // unsigned , default = 0

**Table 9-1883 VD2\_EOTF\_LUT\_DATA\_PORT 0x386F**

Bit(s)	R/W	Default	Description
19:0	R/W	0	eotf_lut_data : // unsigned , default = 0

**Table 9-1884 VD2\_OETF\_LUT\_ADDR\_PORT 0x3870**

Bit(s)	R/W	Default	Description
7:0	R/W	0	oetf_lut_addr : // unsigned , default = 0

**Table 9-1885 VD2\_OETF\_LUT\_DATA\_PORT 0x3871**

Bit(s)	R/W	Default	Description
11:0	R/W	0	oetf_lut_data : // unsigned , default = 0



**Table 9-1886 VD2\_CGAIN\_LUT\_ADDR\_PORT 0x3872**

Bit(s)	R/W	Default	Description
7:0	R/W	0	cgain_lut_addr : // unsigned , default = 0

**Table 9-1887 VD2\_CGAIN\_LUT\_DATA\_PORT 0x3873**

Bit(s)	R/W	Default	Description
11:0	R/W	0	cgain_lut_data : // unsigned , default = 0

**Table 9-1888 VD2\_HDR2\_CGAIN\_COEF0 0x3874**

Bit(s)	R/W	Default	Description
27:16	R/W	0	reg_cgain_coef1 : // unsigned , default = 0
11:0	R/W	0	reg_cgain_coef0 : // unsigned , default = 0

**Table 9-1889 VD2\_HDR2\_CGAIN\_COEF1 0x3875**

Bit(s)	R/W	Default	Description
11:0	R/W	0	reg_cgain_coef2 : // unsigned , default = 0

**Table 9-1890 VD2\_OGAIN\_LUT\_ADDR\_PORT 0x3876**

Bit(s)	R/W	Default	Description
7:0	R/W	0	ogain_lut_addr : // unsigned , default = 0

**Table 9-1891 VD2\_OGAIN\_LUT\_DATA\_PORT 0x3877**

Bit(s)	R/W	Default	Description
11:0	R/W	0	ogain_lut_data : // unsigned , default = 0

**Table 9-1892 VD2\_HDR2\_ADPS\_CTRL 0x3878**

Bit(s)	R/W	Default	Description
6	R/W	1	reg_adpscl_bypass2 : // unsigned , default = 1
5	R/W	1	reg_adpscl_bypass1 : // unsigned , default = 1
4	R/W	1	reg_adpscl_bypass0 : // unsigned , default = 1
1:0	R/W	1	reg_adpscl_mode : // unsigned , default = 1

**Table 9-1893 VD2\_HDR2\_ADPS\_ALPHA0 0x3879**

Bit(s)	R/W	Default	Description
29:16	R/W	0x1000	reg_adpscl_alpha1 : // unsigned , default = 0x1000
13:0	R/W	0x1000	reg_adpscl_alpha0 : // unsigned , default = 0x1000

**Table 9-1894 VD2\_HDR2\_ADPS\_ALPHA1 0x387A**

Bit(s)	R/W	Default	Description
27:24	R/W	0xc	reg_adpscl_shift0 : // unsigned , default = 0xc
23:20	R/W	0xc	reg_adpscl_shift1 : // unsigned , default = 0xc
19:16	R/W	0xc	reg_adpscl_shift2 : // unsigned , default = 0xc
13:0	R/W	0x1000	reg_adpscl_alpha2 : // unsigned , default = 0x1000

**Table 9-1895 VD2\_HDR2\_ADPS\_BETA0 0x387B**

Bit(s)	R/W	Default	Description
20	R/W	0	reg_adpscl_beta0_s : // unsigned , default = 0
19:0	R/W	0xfc000	reg_adpscl_beta0 : // unsigned , default = 0xfc000

**Table 9-1896 VD2\_HDR2\_ADPS\_BETA1 0x387C**

Bit(s)	R/W	Default	Description
20	R/W	0	reg_adpscl_beta1_s : // unsigned , default = 0
19:0	R/W	0xfc000	reg_adpscl_beta1 : // unsigned , default = 0xfc000

**Table 9-1897 VD2\_HDR2\_ADPS\_BETA2 0x387D**

Bit(s)	R/W	Default	Description
20	R/W	0	reg_adpscl_beta2_s : // unsigned , default = 0
19:0	R/W	0xfc000	reg_adpscl_beta2 : // unsigned , default = 0xfc000

**Table 9-1898 VD2\_HDR2\_ADPS\_COEF0 0x387E**

Bit(s)	R/W	Default	Description
27:16	R/W	460	reg_adpscl_ys_coef1 : // unsigned , default = 460
11:0	R/W	1188	reg_adpscl_ys_coef0 : // unsigned , default = 1188

**Table 9-1899 VD2\_HDR2\_ADPS\_COEF1 0x387F**

Bit(s)	R/W	Default	Description
11:0	R/W	104	reg_adpscl_ys_coef2 : // unsigned , default = 104

**Table 9-1900 VD2\_HDR2\_GMUT\_CTRL 0x3880**

Bit(s)	R/W	Default	Description
3:0	R/W	14	reg_gmut_shift : // unsigned , default = 14

**Table 9-1901 VD2\_HDR2\_GMUT\_COEF0 0x3881**

Bit(s)	R/W	Default	Description
31:16	R/W	674	reg_gmut_coef01 : // unsigned , default = 674
15:0	R/W	1285	reg_gmut_coef00 : // unsigned , default = 1285

**Table 9-1902 VD2\_HDR2\_GMUT\_COEF1 0x3882**

Bit(s)	R/W	Default	Description
31:16	R/W	142	reg_gmut_coef10 : // unsigned , default = 142
15:0	R/W	89	reg_gmut_coef02 : // unsigned , default = 89

**Table 9-1903 VD2\_HDR2\_GMUT\_COEF2 0x3883**

Bit(s)	R/W	Default	Description
31:16	R/W	23	reg_gmut_coef12 : // unsigned , default = 23
15:0	R/W	1883	reg_gmut_coef11 : // unsigned , default = 1883

**Table 9-1904 VD2\_HDR2\_GMUT\_COEF3 0x3884**

Bit(s)	R/W	Default	Description
31:16	R/W	180	reg_gmut_coef21 : // unsigned , default = 180
15:0	R/W	34	reg_gmut_coef20 : // unsigned , default = 34

**Table 9-1905 VD2\_HDR2\_GMUT\_COEF4 0x3885**

Bit(s)	R/W	Default	Description
15:0	R/W	1834	reg_gmut_coef22 : // unsigned , default = 1834

**Table 9-1906 VD2\_HDR2\_PIPE\_CTRL1 0x3886**

Bit(s)	R/W	Default	Description
31:24	R/W	4	vblank_num_oetf : // unsigned , default = 4
23:16	R/W	4	hblank_num_oetf : // unsigned , default = 4
15:8	R/W	10	vblank_num_eotf : // unsigned , default = 10
7:0	R/W	10	hblank_num_eotf : // unsigned , default = 10

**Table 9-1907 VD2\_HDR2\_PIPE\_CTRL2 0x3887**

Bit(s)	R/W	Default	Description
31:24	R/W	10	vblank_num_cgain : // unsigned , default = 10
23:16	R/W	10	hblank_num_cgain : // unsigned , default = 10
15:8	R/W	11	vblank_num_gmut : // unsigned , default = 11
7:0	R/W	11	hblank_num_gmut : // unsigned , default = 11

**Table 9-1908 VD2\_HDR2\_PIPE\_CTRL3 0x3888**

Bit(s)	R/W	Default	Description
31:24	R/W	22	vblank_num_adps : // unsigned , default = 22
23:16	R/W	2	hblank_num_adps : // unsigned , default = 2
15:8	R/W	4	vblank_num_uv : // unsigned , default = 4
7:0	R/W	4	hblank_num_uv : // unsigned , default = 4

**Table 9-1909 VD2\_HDR2\_PROC\_WIN1 0x3889**

Bit(s)	R/W	Default	Description
28:16	R/W	0	proc_win_h_ed : // unsigned , default = 0
12:0	R/W	0	proc_win_h_st : // unsigned , default = 0

**Table 9-1910 VD2\_HDR2\_PROC\_WIN2 0x388A**

Bit(s)	R/W	Default	Description
31	R/W	0	proc_win_gmut_en : // unsigned , default = 0
30	R/W	0	proc_win_adps_en : // unsigned , default = 0
29	R/W	0	proc_win_cgain_en : // unsigned , default = 0
28:16	R/W	0	proc_win_v_ed : // unsigned , default = 0
12:0	R/W	0	proc_win_v_st : // unsigned , default = 0

**Table 9-1911 VD2\_HDR2\_MATRIXI\_EN\_CTRL 0x388B**

Bit(s)	R/W	Default	Description
5:4	R/W	0	matrix_gclk_ctrl : // unsigned , default = 0
1	R/W	0	enable_sync_sel : // unsigned , default = 0
0	R/W	0	matrix_conv_en : // unsigned , default = 0

**Table 9-1912 VD2\_HDR2\_MATRIXO\_EN\_CTRL 0x388C**

Bit(s)	R/W	Default	Description
5:4	R/W	0	matrix_gclk_ctrl : // unsigned , default = 0
1	R/W	0	enable_sync_sel : // unsigned , default = 0
0	R/W	0	matrix_conv_en : // unsigned , default = 0

**Table 9-1913 OSD1\_HDR2\_CTRL 0x38A0**

Bit(s)	R/W	Default	Description
20:18	R/W	0	reg_din_swap : // unsigned , default = 0
17	R/W	0	reg_out_fmt : // unsigned , default = 0
16	R/W	0	reg_only_mat : // unsigned , default = 0 ,only use input matrix ,work when hdr disable
15	R/W	0	mat_o_en, //output matrix enable ,only work when hdr enable
14	R/W	0	mat_in_en //input matrix enable ,only work when hdr enable
13	R/W	0	reg_VDIN0_HDR2_top_en : // unsigned , default = 0, hdr enable singal
12	R/W	1	reg_cgain_mode : // unsigned , default = 1
7: 6	R/W	1	reg_gmut_mode : // unsigned , default = 1
5	R/W	0	reg_in_shift : // unsigned , default = 0
4	R/W	1	reg_in_fmt : // unsigned , default = 1
3	R/W	1	reg_eo_enable : // unsigned , default = 1
2	R/W	1	reg_oe_enable : // unsigned , default = 1

**Table 9-1914 OSD1\_HDR2\_CLK\_GATE 0x38A1**

Bit(s)	R/W	Default	Description
31:30	R/W	0	clk_tm : gate clock ctrl (main clock) // unsigned , default = 0
29:28	R/W	0	output : matrix clock gate ctrl // unsigned , default = 0
25:24	R/W	0	input : matrix clock gate ctrl // unsigned , default = 0
23:22	R/W	0	hdr : top cbus clock gate ctrl // unsigned , default = 0
21:20	R/W	0	eotf : cbus clock gate ctrl // unsigned , default = 0
19:18	R/W	0	oetf : cbus clock gate ctrl // unsigned , default = 0
17:16	R/W	0	gamma : mult cbus clock gate ctrl // unsigned , default = 0
15:14	R/W	0	adaptive : cbus scaler clock gate ctrl // unsigned , default = 0
13:12	R/W	0	cgain : cbus clock gate ctrl // unsigned , default = 0
11:10	R/W	0	eotf : clock gate ctrl // unsigned , default = 0
9:8	R/W	0	oetf : clock gate ctrl // unsigned , default = 0
7:6	R/W	0	gamma : mult clock gate ctrl // unsigned , default = 0
5:4	R/W	0	adaptive : scaler clock gate ctrl // unsigned , default = 0

Bit(s)	R/W	Default	Description
3:2	R/W	0	uv : gain clock gate ctrl // unsigned , default = 0
1:0	R/W	0	cgain : clock gate ctrl // unsigned , default = 0

Table 9-1915 OSD1\_HDR2\_MATRIXI\_COEF00\_01 0x38A2

Bit(s)	R/W	Default	Description
28:16	R/W	0	coef00 : // signed , default = 0
12:0	R/W	0	coef01 : // signed , default = 0

Table 9-1916 OSD1\_HDR2\_MATRIXI\_COEF02\_10 0x38A3

Bit(s)	R/W	Default	Description
28:16	R/W	0	coef02 : // signed , default = 0
12:0	R/W	0	coef10 : // signed , default = 0

Table 9-1917 OSD1\_HDR2\_MATRIXI\_COEF11\_12 0x38A4

Bit(s)	R/W	Default	Description
28:16	R/W	0	coef11 : // signed , default = 0
12:0	R/W	0	coef12 : // signed , default = 0

Table 9-1918 OSD1\_HDR2\_MATRIXI\_COEF20\_21 0x38A5

Bit(s)	R/W	Default	Description
28:16	R/W	0	coef20 : // signed , default = 0
12:0	R/W	0	coef21 : // signed , default = 0

Table 9-1919 OSD1\_HDR2\_MATRIXI\_COEF22 0x38A6

Bit(s)	R/W	Default	Description
12:0	R/W	0	coef22 : // signed , default = 0

Table 9-1920 OSD1\_HDR2\_MATRIXI\_COEF30\_31 0x38A7

Bit(s)	R/W	Default	Description
28:16	R/W	0	coef13 : // signed , default = 0
12:0	R/W	0	coef14 : // signed , default = 0

**Table 9-1921 OSD1\_HDR2\_MATRIXI\_COEF32\_40 0x38A8**

Bit(s)	R/W	Default	Description
28:16	R/W	0	coef23 : // signed , default = 0
12:0	R/W	0	coef24 : // signed , default = 0

**Table 9-1922 OSD1\_HDR2\_MATRIXI\_COEF41\_42 0x38A9**

Bit(s)	R/W	Default	Description
28:16	R/W	0	coef15 : // signed , default = 0
12:0	R/W	0	coef25 : // signed , default = 0

**Table 9-1923 OSD1\_HDR2\_MATRIXI\_OFFSET0\_1 0x38AA**

Bit(s)	R/W	Default	Description
26:16	R/W	0	offset0 : // signed , default = 0
10:0	R/W	0	offset1 : // signed , default = 0

**Table 9-1924 OSD1\_HDR2\_MATRIXI\_OFFSET2 0x38AB**

Bit(s)	R/W	Default	Description
10:0	R/W	0	offset2 : // signed , default = 0

**Table 9-1925 OSD1\_HDR2\_MATRIXI\_PRE\_OFFSET0\_1 0x38AC**

Bit(s)	R/W	Default	Description
26:16	R/W	0	pre_offset0 : // signed , default = 0
10:0	R/W	0	pre_offset1 : // signed , default = 0

**Table 9-1926 OSD1\_HDR2\_MATRIXI\_PRE\_OFFSET2 0x38AD**

Bit(s)	R/W	Default	Description
10:0	R/W	0	pre_offset2 : // signed , default = 0

**Table 9-1927 OSD1\_HDR2\_MATRIXO\_COEF00\_01 0x38AE**

Bit(s)	R/W	Default	Description
28:16	R/W	0	coef00 : // signed , default = 0
12:0	R/W	0	coef01 : // signed , default = 0

**Table 9-1928 OSD1\_HDR2\_MATRIXO\_COEF02\_10 0x38AF**

Bit(s)	R/W	Default	Description
28:16	R/W	0	coef02 : // signed , default = 0
12:0	R/W	0	coef10 : // signed , default = 0

**Table 9-1929 OSD1\_HDR2\_MATRIXO\_COEF11\_12 0x38B0**

Bit(s)	R/W	Default	Description
28:16	R/W	0	coef11 : // signed , default = 0
12:0	R/W	0	coef12 : // signed , default = 0

**Table 9-1930 OSD1\_HDR2\_MATRIXO\_COEF20\_21 0x38B1**

Bit(s)	R/W	Default	Description
28:16	R/W	0	coef20 : // signed , default = 0
12:0	R/W	0	coef21 : // signed , default = 0

**Table 9-1931 OSD1\_HDR2\_MATRIXO\_COEF22 0x38B2**

Bit(s)	R/W	Default	Description
12:0	R/W	0	coef22 : // signed , default = 0

**Table 9-1932 OSD1\_HDR2\_MATRIXO\_COEF30\_31 0x38B3**

Bit(s)	R/W	Default	Description
28:16	R/W	0	coef13 : // signed , default = 0
12:0	R/W	0	coef14 : // signed , default = 0

**Table 9-1933 OSD1\_HDR2\_MATRIXO\_COEF32\_40 0x38B4**

Bit(s)	R/W	Default	Description
28:16	R/W	0	coef23 : // signed , default = 0
12:0	R/W	0	coef24 : // signed , default = 0

**Table 9-1934 OSD1\_HDR2\_MATRIXO\_COEF41\_42 0x38B5**

Bit(s)	R/W	Default	Description
28:16	R/W	0	coef15 : // signed , default = 0
12:0	R/W	0	coef25 : // signed , default = 0



**Table 9-1935 OSD1\_HDR2\_MATRIXO\_OFFSET0\_1 0x38B6**

Bit(s)	R/W	Default	Description
26:16	R/W	0	offset0 : // signed , default = 0
10:0	R/W	0	offset1 : // signed , default = 0

**Table 9-1936 OSD1\_HDR2\_MATRIXO\_OFFSET2 0x38B7**

Bit(s)	R/W	Default	Description
10:0	R/W	0	offset2 : // signed , default = 0

**Table 9-1937 OSD1\_HDR2\_MATRIXO\_PRE\_OFFSET0\_1 0x38B8**

Bit(s)	R/W	Default	Description
26:16	R/W	0	pre_offset0 : // signed , default = 0
10:0	R/W	0	pre_offset1 : // signed , default = 0

**Table 9-1938 OSD1\_HDR2\_MATRIXO\_PRE\_OFFSET2 0x38B9**

Bit(s)	R/W	Default	Description
10:0	R/W	0	pre_offset2 : // signed , default = 0

**Table 9-1939 OSD1\_HDR2\_MATRIXI\_CLIP 0x38BA**

Bit(s)	R/W	Default	Description
19:8	R/W	0	comp_th : // unsigned , default = 0
7:5	R/W	0	conv_rs : // unsigned , default = 0
4:3	R/W	0	clmod : // unsigned , default = 0

**Table 9-1940 OSD1\_HDR2\_MATRIXO\_CLIP 0x38BB**

Bit(s)	R/W	Default	Description
19:8	R/W	0	comp_th : // unsigned , default = 0
7:5	R/W	0	conv_rs : // unsigned , default = 0
4:3	R/W	0	clmod : // unsigned , default = 0

**Table 9-1941 OSD1\_HDR2\_CGAIN\_OFFT 0x38BC**

Bit(s)	R/W	Default	Description
26:16	R/W	0	reg_cgain_offt2 : // signed , default = 0
10:0	R/W	0	reg_cgain_offt1 : // signed , default = 0

**Table 9-1942 OSD1\_EOTF\_LUT\_ADDR\_PORT 0x38be**

Bit(s)	R/W	Default	Description
7:0	R/W	0	eotf_lut_addr : // unsigned , default = 0

**Table 9-1943 OSD1\_EOTF\_LUT\_DATA\_PORT 0x38bf**

Bit(s)	R/W	Default	Description
19:0	R/W	0	eotf_lut_data : // unsigned , default = 0

**Table 9-1944 OSD1\_OETF\_LUT\_ADDR\_PORT 0x38c0**

Bit(s)	R/W	Default	Description
7:0	R/W	0	oetf_lut_addr : // unsigned , default = 0

**Table 9-1945 OSD1\_OETF\_LUT\_DATA\_PORT 0x38c1**

Bit(s)	R/W	Default	Description
11:0	R/W	0	oetf_lut_data : // unsigned , default = 0

**Table 9-1946 OSD1\_CGAIN\_LUT\_ADDR\_PORT 0x38c2**

Bit(s)	R/W	Default	Description
7:0	R/W	0	cgain_lut_addr : // unsigned , default = 0

**Table 9-1947 OSD1\_CGAIN\_LUT\_DATA\_PORT 0x38c3**

Bit(s)	R/W	Default	Description
11:0	R/W	0	cgain_lut_data : // unsigned , default = 0

**Table 9-1948 OSD1\_HDR2\_CGAIN\_COEF0 0x38c4**

Bit(s)	R/W	Default	Description
27:16	R/W	0	reg_cgain_coef1 : // unsigned , default = 0
11:0	R/W	0	reg_cgain_coef0 : // unsigned , default = 0

**Table 9-1949 OSD1\_HDR2\_CGAIN\_COEF1 0x38c5**

Bit(s)	R/W	Default	Description
11:0	R/W	0	reg_cgain_coef2 : // unsigned , default = 0

**Table 9-1950 OSD1\_OGAIN\_LUT\_ADDR\_PORT 0x38c6**

Bit(s)	R/W	Default	Description
7:0	R/W	0	ogain_lut_addr : // unsigned , default = 0

**Table 9-1951 OSD1\_OGAIN\_LUT\_DATA\_PORT 0x38c7**

Bit(s)	R/W	Default	Description
11:0	R/W	0	ogain_lut_data : // unsigned , default = 0

**Table 9-1952 OSD1\_HDR2\_ADPS\_CTRL 0x38c8**

Bit(s)	R/W	Default	Description
6	R/W	1	reg_adpscl_bypass2 : // unsigned , default = 1
5	R/W	1	reg_adpscl_bypass1 : // unsigned , default = 1
4	R/W	1	reg_adpscl_bypass0 : // unsigned , default = 1
1:0	R/W	1	reg_adpscl_mode : // unsigned , default = 1

**Table 9-1953 OSD1\_HDR2\_ADPS\_ALPHA0 0x38c9**

Bit(s)	R/W	Default	Description
29:16	R/W	0x1000	reg_adpscl_alpha1 : // unsigned , default = 0x1000
13:0	R/W	0x1000	reg_adpscl_alpha0 : // unsigned , default = 0x1000

**Table 9-1954 OSD1\_HDR2\_ADPS\_ALPHA1 0x38ca**

Bit(s)	R/W	Default	Description
27:24	R/W	0xc	reg_adpscl_shift0 : // unsigned , default = 0xc
23:20	R/W	0xc	reg_adpscl_shift1 : // unsigned , default = 0xc
19:16	R/W	0xc	reg_adpscl_shift2 : // unsigned , default = 0xc
13:0	R/W	0x1000	reg_adpscl_alpha2 : // unsigned , default = 0x1000

**Table 9-1955 OSD1\_HDR2\_ADPS\_BETA0 0x38cb**

Bit(s)	R/W	Default	Description
20	R/W	0	reg_adpscl_beta0_s : // unsigned , default = 0
19:0	R/W	0xfc000	reg_adpscl_beta0 : // unsigned , default = 0xfc000

**Table 9-1956 OSD1\_HDR2\_ADPS\_BETA1 0x38cc**

Bit(s)	R/W	Default	Description
20	R/W	0	reg_adpscl_beta1_s : // unsigned , default = 0
19:0	R/W	0xfc000	reg_adpscl_beta1 : // unsigned , default = 0xfc000

**Table 9-1957 OSD1\_HDR2\_ADPS\_BETA2 0x38cd**

Bit(s)	R/W	Default	Description
20	R/W	0	reg_adpscl_beta2_s : // unsigned , default = 0
19:0	R/W	0xfc000	reg_adpscl_beta2 : // unsigned , default = 0xfc000

**Table 9-1958 OSD1\_HDR2\_ADPS\_COEF0 0x38ce**

Bit(s)	R/W	Default	Description
27:16	R/W	460	reg_adpscl_ys_coef1 : // unsigned , default = 460
11:0	R/W	1188	reg_adpscl_ys_coef0 : // unsigned , default = 1188

**Table 9-1959 OSD1\_HDR2\_ADPS\_COEF1 0x38cf**

Bit(s)	R/W	Default	Description
11:0	R/W	104	reg_adpscl_ys_coef2 : // unsigned , default = 104

**Table 9-1960 OSD1\_HDR2\_GMUT\_CTRL 0x38d0**

Bit(s)	R/W	Default	Description
3:0	R/W	14	reg_gmut_shift : // unsigned , default = 14

**Table 9-1961 OSD1\_HDR2\_GMUT\_COEF0 0x38d1**

Bit(s)	R/W	Default	Description
31:16	R/W	674	reg_gmut_coef01 : // unsigned , default = 674
15:0	R/W	1285	reg_gmut_coef00 : // unsigned , default = 1285

**Table 9-1962 OSD1\_HDR2\_GMUT\_COEF1 0x38d2**

Bit(s)	R/W	Default	Description
31:16	R/W	142	reg_gmut_coef10 : // unsigned , default = 142
15:0	R/W	89	reg_gmut_coef02 : // unsigned , default = 89

**Table 9-1963 OSD1\_HDR2\_GMUT\_COEF2 0x38d3**

Bit(s)	R/W	Default	Description
31:16	R/W	23	reg_gmut_coef12 : // unsigned , default = 23
15:0	R/W	1883	reg_gmut_coef11 : // unsigned , default = 1883

**Table 9-1964 OSD1\_HDR2\_GMUT\_COEF3 0x38d4**

Bit(s)	R/W	Default	Description
31:16	R/W	180	reg_gmut_coef21 : // unsigned , default = 180
15:0	R/W	34	reg_gmut_coef20 : // unsigned , default = 34

**Table 9-1965 OSD1\_HDR2\_GMUT\_COEF4 0x38d5**

Bit(s)	R/W	Default	Description
15:0	R/W	1834	reg_gmut_coef22 : // unsigned , default = 1834

**Table 9-1966 OSD1\_HDR2\_PIPE\_CTRL1 0x38d6**

Bit(s)	R/W	Default	Description
31:24	R/W	4	vblank_num_oetf : // unsigned , default = 4
23:16	R/W	4	hblank_num_oetf : // unsigned , default = 4
15:8	R/W	10	vblank_num_eotf : // unsigned , default = 10
7:0	R/W	10	hblank_num_eotf : // unsigned , default = 10

**Table 9-1967 OSD1\_HDR2\_PIPE\_CTRL2 0x38d7**

Bit(s)	R/W	Default	Description
31:24	R/W	10	vblank_num_cgain : // unsigned , default = 10
23:16	R/W	10	hblank_num_cgain : // unsigned , default = 10
15:8	R/W	11	vblank_num_gmut : // unsigned , default = 11
7:0	R/W	11	hblank_num_gmut : // unsigned , default = 11

**Table 9-1968 OSD1\_HDR2\_PIPE\_CTRL3 0x38d8**

Bit(s)	R/W	Default	Description
31:24	R/W	22	vblank_num_adps : // unsigned , default = 22
23:16	R/W	2	hblank_num_adps : // unsigned , default = 2
15:8	R/W	4	vblank_num_uv : // unsigned , default = 4
7:0	R/W	4	hblank_num_uv : // unsigned , default = 4

**Table 9-1969 OSD1\_HDR2\_PROC\_WIN1 0x38d9**

Bit(s)	R/W	Default	Description
28:16	R/W	0	proc_win_h_ed : // unsigned , default = 0
12:0	R/W	0	proc_win_h_st : // unsigned , default = 0

**Table 9-1970 OSD1\_HDR2\_PROC\_WIN2 0x38da**

Bit(s)	R/W	Default	Description
31	R/W	0	proc_win_gmut_en : // unsigned , default = 0
30	R/W	0	proc_win_adps_en : // unsigned , default = 0
29	R/W	0	proc_win_cgain_en : // unsigned , default = 0
28:16	R/W	0	proc_win_v_ed : // unsigned , default = 0
12:0	R/W	0	proc_win_v_st : // unsigned , default = 0

**Table 9-1971 OSD1\_HDR2\_MATRIXI\_EN\_CTRL 0x38db**

Bit(s)	R/W	Default	Description
5:4	R/W	0	matrix_gclk_ctrl : // unsigned , default = 0
1	R/W	0	enable_sync_sel : // unsigned , default = 0
0	R/W	0	matrix_conv_en : // unsigned , default = 0

**Table 9-1972 OSD1\_HDR2\_MATRIXO\_EN\_CTRL 0x38dc**

Bit(s)	R/W	Default	Description
5:4	R/W	0	matrix_gclk_ctrl : // unsigned , default = 0
1	R/W	0	enable_sync_sel : // unsigned , default = 0
0	R/W	0	matrix_conv_en : // unsigned , default = 0

### 9.2.3.42 VDIN Registers

VDIN0\_SCALE\_COEF\_IDX 0x1200

VDIN0\_SCALE\_COEF 0x1201

**Table 9-1973 VDIN0\_COM\_CTRL0 0x1202**

Bit(s)	R/W	Default	Description
31	R/W	0	mpeg_to_vdin_sel, 0: mpeg source to NR directly, 1: mpeg source pass through here
30	R/W	0	mpeg_field info which can be written by software
29	R/W	0	force go_field, pulse signal
28	R/W	0	force go_line, pulse signal

Bit(s)	R/W	Default	Description
27	R/W	0	enable mpeg_go_field input signal
26-20	R/W	0	hold lines
19	R/W	0	delay go_field function enable
18-12	R/W	0	delay go_field line number
11-10	R/W	0	component2 output switch, 00: select component0 in, 01: select component1 in, 10: select component2 in
9-8	R/W	0	component1 output switch, 00: select component0 in, 01: select component1 in, 10: select component2 in
7-6	R/W	0	component0 output switch, 00: select component0 in, 01: select component1 in, 10: select component2 in
5	R/W	0	input window selection function enable
4	R/W	0	enable VDIN common data input, otherwise there will be no video data input
3-0	R/W	0	vdin selection, 1: mpeg_in from dram; 2: bt656 input; 3: Reserved (component input); 4: Reserved(tvdecoder input); 5: Reserved(hdmi rx input); 6: reserved(digital video input); 7: Wr_back 0; 8: reserved(MIPI CSI2); 9: Wr_back 1; 10: Reserved(second bt656 input); otherwise no input.

Table 9-1974 VDIN0\_ACTIVE\_MAX\_PIX\_CNT\_STATUS 0x1203

Bit(s)	R/W	Default	Description
28-16	R	0	active_max_pix_cnt, readonly
12-0	R	0	active_max_pix_cnt_shadow, readonly

Table 9-1975 VDIN0\_LCNT\_STATUS 0x1204

Bit(s)	R/W	Default	Description
28-16	R	0	go_line_cnt, readonly
12-0	R	0	active_line_cnt, readonly

Table 9-1976 VDIN0\_COM\_STATUS0 0x1205

Bit(s)	R/W	Default	Description
17	R	0	Vid_wr_pending_ddr_wrrsp
16	R	0	Curr_pic_sec
15	R	0	Curr_pic_sec_sav
14-3	R	0	lifo_buf_cnt
2	R	0	vdin_direct_done status
1	R	0	vdin_nr_done status
0	R	0	field

**Table 9-1977 VDIN0\_COM\_STATUS1 0x1206**

Bit(s)	R/W	Default	Description
31	R	0	vdi4 fifo overflow
29-24	R	0	vdi3_asfifo_cnt
23	R	0	vdi3 fifo overflow
21-16	R	0	vdi3_asfifo_cnt
15	R	0	vdi2 fifo overflow
13-8	R	0	vdi2_asfifo_cnt
7	R	0	vdi1 fifo overflow
5-0	R	0	vdi1_asfifo_cnt

**Table 9-1978 VDIN0\_LCNT\_SHADOW\_STATUS 0x1207**

Bit(s)	R/W	Default	Description
28-16	R	0	go_line_cnt_shadow, readonly
12-0	R	0	active_line_cnt_shadow, readonly

**Table 9-1979 VDIN0\_ASFIFO\_CTRL0 0x1208**

Bit(s)	R/W	Default	Description
23	R/W	0	vdi2 DE enable
22	R/W	0	vdi2 go field enable
21	R/W	0	vdi2 go line enable
20	R/W	0	vdi2 if true, negative active input vsync
19	R/W	0	vdi2 if true, negative active input hsync
18	R/W	0	vdi2 vsync soft reset fifo enable
17	R/W	0	vdi2 overflow status clear
16	R/W	0	vdi2 asfifo soft reset, level signal
7	R/W	0	Vdi1 DE enable
6	R/W	0	Vdi1 go field enable
5	R/W	0	Vdi1 go line enable
4	R/W	0	Vdi1 if true, negative active input vsync
3	R/W	0	Vdi1 if true, negative active input hsync
2	R/W	0	Vdi1 vsync soft reset fifo enable
1	R/W	0	Vdi1 overflow status clear
0	R/W	0	Vdi1 asfifo soft reset, level signal



**Table 9-1980 VDIN0\_ASFIFO\_CTRL1 0x1209**

Bit(s)	R/W	Default	Description
23	R/W	0	Vdi4 DE enable
22	R/W	0	Vdi4 go field enable
21	R/W	0	Vdi4 go line enable
20	R/W	0	Vdi4 if true, negative active input vsync
19	R/W	0	Vdi4 if true, negative active input hsync
18	R/W	0	Vdi4 vsync soft reset fifo enable
17	R/W	0	Vdi4 overflow status clear
16	R/W	0	Vdi4 asfifo soft reset, level signal
7	R/W	0	Vdi3 DE enable
6	R/W	0	Vdi3 go field enable
5	R/W	0	Vdi3 go line enable
4	R/W	0	Vdi3 if true, negative active input vsync
3	R/W	0	Vdi3 if true, negative active input hsync
2	R/W	0	Vdi3 vsync soft reset fifo enable
1	R/W	0	Vdi3 overflow status clear
0	R/W	0	Vdi3 asfifo soft reset, level signal

**Table 9-1981 VDIN0\_WIDTHM1I\_WIDTHM1O 0x120a**

Bit(s)	R/W	Default	Description
28-16	R/W	0	input width minus 1, after the window function
12-0	R/W	0	output width minus 1

**Table 9-1982 VDIN0\_SC\_MISC\_CTRL 0x120b**

Bit(s)	R/W	Default	Description
14-8	R/W	0	hsc_ini_pixi_ptr, signed data, only useful when short_lineo_en is true
7	R/W	0	prehsc_en
6	R/W	0	hsc_en
5	R/W	0	hsc_short_lineo_en, short line output enable
4	R/W	0	hsc_nearest_en
3	R/W	0	Hsc_phase0_always_en
2-0	R/W	0	hsc_bank_length

**Table 9-1983 VDIN0\_HSC\_PHASE\_STEP 0x120c**

Bit(s)	R/W	Default	Description
28-24	R/W	0	integer portion
23-0	R/W	0	fraction portion

**Table 9-1984 VDIN0\_HSC\_INI\_CTRL 0x120d**

Bit(s)	R/W	Default	Description
30-29	R/W	0	hscale rpt_p0_num
28-24	R/W	0	hscale ini_rcv_num
23-0	R/W	0	hscale ini_phase

**Table 9-1985 VDIN0\_COM\_STATUS2 0x120e**

Bit(s)	R/W	Default	Description
23	R	0	Vdi7 fifo overflow
21-16	R	0	Vdi7_asfifo_cnt
15	R	0	Vdi6 fifo overflow
13-8	R	0	Vdi6_asfifo_cnt
7	R	0	vdi5 fifo overflow
5-0	R	0	vdi5_asfifo_cnt

**Table 9-1986 VDIN0\_ASFIFO\_CTRL2 0x120f**

Bit(s)	R/W	Default	Description
25	R/W	0	if true, decimation counter sync with first valid DE in the field, //otherwise the decimation counter is not sync with external signal
24	R/W	0	decimation de enable
23-20	R/W	0	decimation phase, which counter value use to decimate,
19-16	R/W	0	decimation number, 0: not decimation, 1: decimation 2, 2: decimation 3 ....
7	R/W	0	Vdi5 DE enable
6	R/W	0	Vdi5 go field enable
5	R/W	0	Vdi5 go line enable
4	R/W	0	Vdi5 if true, negative active input vsync
3	R/W	0	Vdi5 if true, negative active input hsync
2	R/W	0	Vdi5 vsync soft reset fifo enable
1	R/W	0	Vdi5 overflow status clear
0	R/W	0	Vdi5 asfifo soft reset, level signal

**Table 9-1987 VDIN0\_MATRIX\_CTRL 0x1210**

Bit(s)	R/W	Default	Description
7	R/W	0	highlight_enable
6	R/W	0	probe_post, if true, probe pixel data after matrix, otherwise probe pixel data before matrix
5-4	R/W	0	probe_sel, 00: select matrix 0, 01: select matrix 1, otherwise select nothing
3-2	R/W	0	matrix_coef_idx selection, 00: select mat0, 01: select mat1, otherwise select nothing
1	R/W	0	mat1 conversion matrix enable
0	R/W	0	Mat0 conversion matrix enable

**Table 9-1988 VDIN0\_MATRIX\_COEF00\_01 0x1211**

Bit(s)	R/W	Default	Description
28-16	R/W	0	coef00
12-0	R/W	0	coef01

**Table 9-1989 VDIN0\_MATRIX\_COEF02\_10 0x1212**

Bit(s)	R/W	Default	Description
28-16	R/W	0	coef02
12-0	R/W	0	Coef10

**Table 9-1990 VDIN0\_MATRIX\_COEF11\_12 0x1213**

Bit(s)	R/W	Default	Description
28-16	R/W	0	Coef11
12-0	R/W	0	Coef12

**Table 9-1991 VDIN0\_MATRIX\_COEF20\_21 0x1214**

Bit(s)	R/W	Default	Description
28-16	R/W	0	Coef20
12-0	R/W	0	coef21

**Table 9-1992 VDIN0\_MATRIX\_COEF22 0x1215**

Bit(s)	R/W	Default	Description
18-16	R/W	0	convrs
7-0	R/W	0	Coef22

**Table 9-1993 VDIN0\_MATRIX\_OFFSET0\_1 0x1216**

Bit(s)	R/W	Default	Description
26-16	R/W	0	offset0
10-0	R/W	0	Offset1

**Table 9-1994 VDIN0\_MATRIX\_OFFSET2 0x1217**

Bit(s)	R/W	Default	Description
10-0	R/W	0	Offset2

**Table 9-1995 VDIN0\_MATRIX\_PRE\_OFFSET0\_1 0x1218**

Bit(s)	R/W	Default	Description
26-16	R/W	0	Pre_offset0
10-0	R/W	0	Pre_Offset1

**Table 9-1996 VDIN0\_MATRIX\_PRE\_OFFSET2 0x1219**

Bit(s)	R/W	Default	Description
10-0	R/W	0	Pre_Offset2

**Table 9-1997 VDIN0\_LFIFO\_CTRL 0x121a**

Bit(s)	R/W	Default	Description
11-0	R/W	0	lfifo_buf_size

**Table 9-1998 VDIN0\_COM\_GCLK\_CTRL 0x121b**

Bit(s)	R/W	Default	Description
15-14	R/W	0	Gate clock control for blackbar detector
13-12	R/W	0	Gate clock control for hist
11-10	R/W	0	Gate clock control for line fifo
9-8	R/W	0	Gate clock control for matrix
7-6	R/W	0	Gate clock control for horizontal scaler
5-4	R/W	0	Gate clock control for pre scaler
3-2	R/W	0	Gate clock control for vdin_com_proc
1-0	R/W	0	Gate clock control for the vdin reg

**Table 9-1999 VDIN0\_INTF\_WIDTHM1 0x121c**

Bit(s)	R/W	Default	Description
26	R/W	0	VDIN write mif bvalid_sel: 1. Bvalid_signal from bus, 0: bytes_wr handshakes
25	R/W	0	VDIN write mif burst last sel: 1. All kind of burst last signal include ext_data_last. 0. Used the normal burst last signal
12-0	R/W	0	VDIN input interface width minus 1, before the window function, after the de decimation

**Table 9-2000 VDIN0\_WR\_CTRL2 0x121f**

Bit(s)	R/W	Default	Description
19	R/W	0	Vdin0 wr bit10 mode
18	R/W	0	Data_ext_en 1: send out data if req was interrupt by soft reset 0 : normal mode
17:16	R/W	1	Words_lim[1:0] : it would not send out request before Words_lim *16 words were ready
15:12	R/W	1	Burst_lim : 00 , 1 word in 1burst , 01 ,2 words in 1burst, 10, 4 words in 1burst , 11 reserved
10:9	R/W	0	Words_lim[3:2]
8	R/W	0	1: discard data before line fifo, 0: normal mode
7-0	R/W	0	Write chroma canvas address, for NV12/21 mode.

**Table 9-2001 VDIN0\_WR\_CTRL 0x1220**

Bit(s)	R/W	Default	Description
31:30	R/W	0	vdin0_wr_mif_hconv_mode. Applicable only to vdin_write_format=0 or 2. 0=Output every even pixel's CbCr; 1=Output every odd pixel's CbCr; 2=Output an average value per even&odd pair of pixels; 3=Output all CbCr. Only applies to vdin_write_format =2.
29	R/W	0	vdin0_wr_mif_no_clk_gate. If true, enable free-run clock.
28	R/W	0	clear write response counter in the vdin write memory interface
27	R/W	1	eol_sel, 1: use eol as the line end indication, 0: use width as line end indication in the vdin write memory interface
26	R/W	0	vcp_nr_en. Only used in VDIN0. NOT used in VDIN1
25	R/W	1	vcp_wr_en Only used in VDIN0. NOT used in VDIN1
24	R/W	1	vcp_in_en Only used in VDIN0. NOT used in VDIN1
23	R/W	1	vdin frame reset enable, if true, it will provide frame reset during go_field(vsync) to the modules after that
22	R/W	1	vdin line fifo soft reset enable, meaning, if true line fifo will reset during go_field (vsync)
21	R/W	0	vdin direct write done status clear bit
20	R/W	0	vdin NR write done status clear bit
19	R/W	0	Vdin0_wr words swap : swap the 2 64bits word in 128 words
18	R/W	0	vdin0_wr_mif_swap_cbcr. Applicable only to vdin_write_format =2.

Bit(s)	R/W	Default	Description
			0=Output CbCr (NV12); 1=Output CrCb (NV21);
17:16	R/W	0	vdin0_wr_mif_vconv_mode. Applicable only to vdin_write_format=2. 0=Output every even line's CbCr; 1=Output every odd line's CbCr; 2=Reserved; 3=Output all CbCr.
13-12	R/W	0	vdin_write_format, 0: 4:2:2 to one canvas; 1: 4:4:4 to one canvas; 2: Y to luma canvas, CbCr to chroma canvas, for NV12/21; 3: yuv422 full pack mode
11	R/W	0	vdin write canvas double buffer enable, means the canvas address will be latched by vsync before using
9	R/W	0	vdin write request urgent
8	R/W	0	vdin write request enable
7-0	R/W	0	Write canvas address (For NV12/21 mode, it's LUMA canvas)

Table 9-2002 VDIN0\_WR\_H\_START\_END 0x1221

Bit(s)	R/W	Default	Description
29	R/W	0	if true, horizontal reverse
28-16	R/W	0	start
12-0	R/W	0	end

Table 9-2003 VDIN0\_WR\_V\_START\_END 0x1222

Bit(s)	R/W	Default	Description
29	R/W	0	if true, vertical reverse
28-16	R/W	0	start
12-0	R/W	0	end

Table 9-2004 VDIN0\_VSC\_PHASE\_STEP 0x1223

Bit(s)	R/W	Default	Description
24-16	R/W	0	integer portion
19-0	R/W	0	fraction portion

Table 9-2005 VDIN0\_VSC\_INI\_CTRL 0x1224

Bit(s)	R/W	Default	Description
23	R/W	0	vsc_en, vertical scaler enable
21	R/W	0	vsc_phase0_always_en, when scale up, you have to set it to 1
20-16	R/W	0	ini skip_line_num
15-0	R/W	0	vscaler ini_phase

**Table 9-2006 VDIN0\_SCIN\_HEIGHTM1 0x1225**

Bit(s)	R/W	Default	Description
12-0	R/W	0x437	scaler input height minus 1

**Table 9-2007 VDIN0\_DUMMY\_DATA 0x1226**

Bit(s)	R/W	Default	Description
23-16	R/W	0	dummy component 0
15-8	R/W	0x80	dummy component 1
7-0	R/W	0x80	dummy component 2

**Table 9-2008 VDIN0\_MATRIX\_PROBE\_COLOR 0x1228**

Bit(s)	R/W	Default	Description
29-20	R/W	0	component 0
19-10	R/W	0	component 1
9-0	R/W	0	component 2

**Table 9-2009 VDIN0\_MATRIX\_HL\_COLOR 0x1229**

Bit(s)	R/W	Default	Description
23-16	R/W	0	component 0
15-8	R/W	0	component 1
7-0	R/W	0	component 2

**Table 9-2010 VDIN0\_MATRIX\_PROBE\_POS 0x122a**

Bit(s)	R/W	Default	Description
28-16	R/W	0	probe x, position
12-0	R/W	0	probe y, position

**Table 9-2011 VDIN0\_HIST\_CTRL 0x1230**

Bit(s)	R/W	Default	Description
31-24	R/W	0	No use
23-16	R/W	0	No use
11	R/W	0	Hist 34bin only mode
10-9	R/W	0	ldim_stts_din_sel, 00: from matrix0 dout, 01: from vsc_dout, 10: from matrix1 dout, 11: form matrix1 din
8	R/W	0	ldim_stts_en
6-5	R/W	0	hist_dnlp_low the real pixels in each bins got by VDIN_DNLP_HISTXX should multiple with $2^{(dnlp\_low+3)}$

Bit(s)	R/W	Default	Description
3-2	R/W	0	hist_din_sel the source used for hist statistics. 2'b00: from MAT0_dout; 2'b01: from vsc_dout; 2'b10: from mat1_dout, 3: mat1_din
1	R/W	0	hist_win_en 1'b0: hist used for full picture; 1'b1: hist used for pixels within hist window
0	R/W	0	hist_spl_en 1'b0: disable hist readback; 1'b1: enable hist readback

Table 9-2012 VDIN0\_HIST\_H\_START\_END 0x1231

Bit(s)	R/W	Default	Description
28-16	R/W	0	hist_hstart horizontal start value to define hist window
12-0	R/W	0	hist_hend horizontal end value to define hist window

Table 9-2013 VDIN0\_HIST\_V\_START\_END 0x1232

Bit(s)	R/W	Default	Description
28-16	R/W	0	hist_vstart vertical start value to define hist window
12-0	R/W	0	hist_vend vertical end value to define hist window

Table 9-2014 VDIN0\_HIST\_MAX\_MIN 0x1233

Bit(s)	R/W	Default	Description
15-8	R	0	hist_max maximum value
7-0	R	0	hist_min minimum value

Table 9-2015 VDIN0\_HIST\_SPL\_VAL 0x1234

Bit(s)	R/W	Default	Description
31-0	R	0	hist_spl_rd , counts for the total luma value

Table 9-2016 VDIN0\_HIST\_SPL\_PIX\_CNT 0x1235

Bit(s)	R/W	Default	Description
21-0	R	0	hist_spl_pixel_count, counts for the total calculated pixels

Table 9-2017 VDIN0\_HIST\_CHROMA\_SUM 0x1236

Bit(s)	R/W	Default	Description
31-0	R	0	hist_chroma_sum , counts for the total chroma value

//0-255 are splited to 64 bins evenly, and VDIN\_DNLP\_HISTXX

//are the statistic number of pixels that within each bin.



Bit(s)	R/W	Default	Description
31-16	R	0	counts for the 2nd bin
15-0	R	0	counts for the 1st bin

**Table 9-2018 VDINO\_DNLP\_HIST01 0x1238**

Bit(s)	R/W	Default	Description
31-16	R	0	counts for the 4th bin
15-0	R	0	counts for the 3rd bin

**Table 9-2019 VDINO\_DNLP\_HIST02 0x1239**

Bit(s)	R/W	Default	Description
31-16	R	0	counts for the 6th bin
15-0	R	0	counts for the 5th bin

**Table 9-2020 VDINO\_DNLP\_HIST03 0x123a**

Bit(s)	R/W	Default	Description
31-16	R	0	counts for the 8th bin
15-0	R	0	counts for the 7th bin

**Table 9-2021 VDINO\_DNLP\_HIST04 0x123b**

Bit(s)	R/W	Default	Description
31-16	R	0	counts for the 10th bin
15-0	R	0	counts for the 9th bin

**Table 9-2022 VDINO\_DNLP\_HIST05 0x123c**

Bit(s)	R/W	Default	Description
31-16	R	0	counts for the 12th bin
15-0	R	0	counts for the 11th bin

**Table 9-2023 VDINO\_DNLP\_HIST06 0x123d**

Bit(s)	R/W	Default	Description
31-16	R	0	counts for the 14th bin
15-0	R	0	counts for the 13th bin

**Table 9-2024 VDINO\_DNLP\_HIST07 0x123e**

Bit(s)	R/W	Default	Description
31-16	R	0	counts for the 16th bin
15-0	R	0	counts for the 15th bin

**Table 9-2025 VDINO\_DNLP\_HIST08 0x123f**

Bit(s)	R/W	Default	Description
31-16	R	0	counts for the 18th bin
15-0	R	0	counts for the 17th bin

**Table 9-2026 VDINO\_DNLP\_HIST09 0x1240**

Bit(s)	R/W	Default	Description
31-16	R	0	counts for the 20th bin
15-0	R	0	counts for the 19th bin

**Table 9-2027 VDINO\_DNLP\_HIST10 0x1241**

Bit(s)	R/W	Default	Description
31-16	R	0	counts for the 22nd bin
15-0	R	0	counts for the 21st bin

**Table 9-2028 VDINO\_DNLP\_HIST11 0x1242**

Bit(s)	R/W	Default	Description
31-16	R	0	counts for the 24th bin
15-0	R	0	counts for the 23rd bin

**Table 9-2029 VDINO\_DNLP\_HIST12 0x1243**

Bit(s)	R/W	Default	Description
31-16	R	0	counts for the 26th bin
15-0	R	0	counts for the 25th bin

**Table 9-2030 VDINO\_DNLP\_HIST13 0x1244**

Bit(s)	R/W	Default	Description
31-16	R	0	counts for the 28th bin
15-0	R	0	counts for the 27th bin

**Table 9-2031 VDIN0\_DNLP\_HIST14 0x1245**

Bit(s)	R/W	Default	Description
31-16	R	0	counts for the 30th bin
15-0	R	0	counts for the 29th bin

**Table 9-2032 VDIN0\_DNLP\_HIST15 0x1246**

Bit(s)	R/W	Default	Description
31-16	R	0	counts for the 32nd bin
15-0	R	0	counts for the 31st bin

**Table 9-2033 VDIN0\_DNLP\_HIST16 0x1247**

Bit(s)	R/W	Default	Description
31-16	R	0	counts for the 34th bin
15-0	R	0	counts for the 33rd bin

**Table 9-2034 VDIN0\_DNLP\_HIST17 0x1248**

Bit(s)	R/W	Default	Description
31-16	R	0	counts for the 36th bin
15-0	R	0	counts for the 35th bin

**Table 9-2035 VDIN0\_DNLP\_HIST18 0x1249**

Bit(s)	R/W	Default	Description
31-16	R	0	counts for the 38th bin
15-0	R	0	counts for the 37th bin

**Table 9-2036 VDIN0\_DNLP\_HIST19 0x124a**

Bit(s)	R/W	Default	Description
31-16	R	0	counts for the 40th bin
15-0	R	0	counts for the 39th bin

**Table 9-2037 VDIN0\_DNLP\_HIST20 0x124b**

Bit(s)	R/W	Default	Description
31-16	R	0	counts for the 42nd bin
15-0	R	0	counts for the 41st bin

**Table 9-2038 VDINO\_DNLP\_HIST21 0x124c**

Bit(s)	R/W	Default	Description
31-16	R	0	counts for the 44th bin
15-0	R	0	counts for the 43rd bin

**Table 9-2039 VDINO\_DNLP\_HIST22 0x124d**

Bit(s)	R/W	Default	Description
31-16	R	0	counts for the 46th bin
15-0	R	0	counts for the 45th bin

**Table 9-2040 VDINO\_DNLP\_HIST23 0x124e**

Bit(s)	R/W	Default	Description
31-16	R	0	counts for the 48th bin
15-0	R	0	counts for the 47th bin

**Table 9-2041 VDINO\_DNLP\_HIST24 0x124f**

Bit(s)	R/W	Default	Description
31-16	R	0	counts for the 50th bin
15-0	R	0	counts for the 49th bin

**Table 9-2042 VDINO\_DNLP\_HIST25 0x1250**

Bit(s)	R/W	Default	Description
31-16	R	0	counts for the 52nd bin
15-0	R	0	counts for the 51st bin

**Table 9-2043 VDINO\_DNLP\_HIST26 0x1251**

Bit(s)	R/W	Default	Description
31-16	R	0	counts for the 54th bin
15-0	R	0	counts for the 53rd bin

**Table 9-2044 VDINO\_DNLP\_HIST27 0x1252**

Bit(s)	R/W	Default	Description
31-16	R	0	counts for the 56th bin
15-0	R	0	counts for the 55th bin

**Table 9-2045 VDIN0\_DNLP\_HIST28 0x1253**

Bit(s)	R/W	Default	Description
31-16	R	0	counts for the 58th bin
15-0	R	0	counts for the 57th bin

**Table 9-2046 VDIN0\_DNLP\_HIST29 0x1254**

Bit(s)	R/W	Default	Description
31-16	R	0	counts for the 60th bin
15-0	R	0	counts for the 59th bin

**Table 9-2047 VDIN0\_DNLP\_HIST30 0x1255**

Bit(s)	R/W	Default	Description
31-16	R	0	counts for the 62nd bin
15-0	R	0	counts for the 61st bin

**Table 9-2048 VDIN0\_DNLP\_HIST31 0x1256**

Bit(s)	R/W	Default	Description
31-16	R	0	counts for the 64th bin
15-0	R	0	counts for the 63rd bin

**Table 9-2049 VDIN0\_LDIM\_STTS\_HIST\_REGION\_IDX 0x1257**

Bit(s)	R/W	Default	Description
31	R	0	local dimming max statistic enable
28	R	0	eol enable
27-25	R	0	vertical line overlap number for max finding
24-22	R	0	horizontal pixel overlap number, 0: 17 pix, 1: 9 pix, 2: 5 pix, 3: 3 pix, 4: 0 pix
20	R	0	1,2,1 low pass filter enable before max/hist statistic
19-16	R	0	region H/V position index, refer to VDIN_LDIM_STTS_HIST_SET_REGION
15	R	0	1: region read index auto increase per read to VDIN_LDIM_STTS_HIST_READ_REGION
6-0	R	0	region read index

Table 9-2050 VDIN0\_LDIM\_STTS\_HIST\_SET\_REGION 0x1258

Bit(s)	R/W	Default	Description
28:16	R	0	if VDIN_LDIM_STTS_HIST_REGION_IDX[19:16] == 5'h0: read/write hvstart0 if VDIN_LDIM_STTS_HIST_REGION_IDX[19:16] == 5'h1: read/write hend01 if VDIN_LDIM_STTS_HIST_REGION_IDX[19:16] == 5'h2: read/write vend01 if VDIN_LDIM_STTS_HIST_REGION_IDX[19:16] == 5'h3: read/write hend23 if VDIN_LDIM_STTS_HIST_REGION_IDX[19:16] == 5'h4: read/write vend23 if VDIN_LDIM_STTS_HIST_REGION_IDX[19:16] == 5'h5: read/write hend45 if VDIN_LDIM_STTS_HIST_REGION_IDX[19:16] == 5'h6: read/write vend45 if VDIN_LDIM_STTS_HIST_REGION_IDX[19:16] == 5'd7: read/write hend67 if VDIN_LDIM_STTS_HIST_REGION_IDX[19:16] == 5'h8: read/write vend67 if VDIN_LDIM_STTS_HIST_REGION_IDX[19:16] == 5'h9: read/write hend89 if VDIN_LDIM_STTS_HIST_REGION_IDX[19:16] == 5'ha: read/write vend89 //hvstart0, Bit 28:16 row0 vstart, Bit 12:0 col0 hstart //hend01, Bit 28:16 col1 hend, Bit 12:0 col0 hend //vend01, Bit 28:16 row1 vend, Bit 12:0 row0 vend //hend23, Bit 28:16 col3 hend, Bit 12:0 col2 hend //vend23, Bit 28:16 row3 vend, Bit 12:0 row2 vend //hend45, Bit 28:16 col5 hend, Bit 12:0 col4 hend //vend45, Bit 28:16 row5 vend, Bit 12:0 row4 vend //hend67, Bit 28:16 col7 hend, Bit 12:0 col6 hend //vend67, Bit 28:16 row7 vend, Bit 12:0 row6 vend //hend89, Bit 28:16 col9 hend, Bit 12:0 col8 hend //vend89, Bit 28:16 row9 vend, Bit 12:0 row8 vend
12:0	R	0	

Table 9-2051 VDIN0\_LDIM\_STTS\_HIST\_READ\_REGION 0x1259

Bit(s)	R/W	Default	Description
29:20	R	0	Max_comp2
19:10	R	0	Max_comp1
9:0	R	0	Max_comp0

Table 9-2052 VDIN0\_MEAS\_CTRL0 0x125a

Bit(s)	R/W	Default	Description
18	R/W	0	reset bit, high active
17	R/W	0	if true, widen hs/vs pulse
16	R/W	0	vsync total counter always accumulating enable
15-12	R/W	0	select hs/vs of video input channel to measure, 0: no selection, 1:vdi1, 2:vid2: 3: vid3, 4:vid4, 5:vdi5, 6:vdi6, 7:vdi7, 8:vdi8, 9:vdi9.
11-4	R/W	0	vsync_span, define how many vsync span need to measure
2-0	R/W	0	meas_hs_index, index to select which HS counter/range

Table 9-2053 VDIN0\_MEAS\_VS\_COUNT\_HI 0x125b

Bit(s)	R/W	Default	Description
19-16	R	0	meas_ind_total_count_n, every number of sync_span vsyncs, this count add 1
15-0	R	0	high bit portion of vsync total counter

Table 9-2054 VDIN0\_MEAS\_VS\_COUNT\_LO 0x125c

Bit(s)	R/W	Default	Description
31-0	R	0	low bit portion of vsync total counter

VDIN0\_MEAS\_HS\_RANGE 0x125d

//according to the meas\_hs\_index in register VDIN\_MEAS\_CTRL0

//meas\_hs\_index == 0, first hs range

//meas\_hs\_index == 1, second hs range

//meas\_hs\_index == 2, third hs range

//meas\_hs\_index == 3, fourth hs range

Bit(s)	R/W	Default	Description
28-16	R	0	count_start
12-0	R	0	count_end

VDIN0\_MEAS\_HS\_COUNT 0x125e

//according to the meas\_hs\_index in register VDIN\_MEAS\_CTRL0,

//meas\_hs\_index == 0, first range hs counter,

//meas\_hs\_index == 1, second range hs

//meas\_hs\_index == 2, third range hs

//meas\_hs\_index == 3, fourth range hs

Bit(s)	R/W	Default	Description
23-0	R	0	Hs counter

Table 9-2055 VDIN0\_BLKBAR\_CTRL1 0x125f

Bit(s)	R/W	Default	Description
8	R/W	0	white_enable
7-0	R/W	0	blkbar_white_level

Table 9-2056 VDIN0\_BLKBAR\_CTRL0 0x1260

Bit(s)	R/W	Default	Description
31-24	R/W	0	blkbar_black_level threshold to judge a black point
20-8	R/W	0	blkbar_hwidth left and right region width
7-5	R/W	0	blkbar_comp_sel select yin or uin or vin to be the valid input
4	R/W	0	blkbar_sw_statistic_en enable software statistic of each block black points number
3	R/W	0	blkbar_det_en

Bit(s)	R/W	Default	Description
2-1	R/W	0	blkbar_din_sel, 0:mat0_dout, 1:vsc_dout, 2:mat1_dout, 3:mat1_din
0	R/W	0	Blkbar_det_top_en

Table 9-2057 VDIN0\_BLKBAR\_H\_START\_END 0x1261

Bit(s)	R/W	Default	Description
28-16	R/W	0	blkbar_hstart. Left region start
12-0	R/W	0	blkbar_hend. Right region end

Table 9-2058 VDIN0\_BLKBAR\_V\_START\_END 0x1262

Bit(s)	R/W	Default	Description
28-16	R/W	0	blkbar_vstart.
12-0	R/W	0	blkbar_vend.

Table 9-2059 VDIN0\_BLKBAR\_CNT\_THRESHOLD 0x1263

Bit(s)	R/W	Default	Description
19-0	R/W	0	blkbar_cnt_threshold. threshold to judge whether a block is totally black

Table 9-2060 VDIN0\_BLKBAR\_ROW\_TH1\_TH2 0x1264

Bit(s)	R/W	Default	Description
28-16	R/W	0	blkbar_row_th1. //threshold of the top blackbar
12-0	R/W	0	blkbar_row_th2 //threshold of the bottom blackbar

Table 9-2061 VDIN0\_BLKBAR\_IND\_LEFT\_START\_END 0x1265

Bit(s)	R/W	Default	Description
28-16	R	0	blkbar_ind_left_start. horizontal start of the left region in the current searching
12-0	R	0	blkbar_ind_left_end. horizontal end of the left region in the current searching

Table 9-2062 VDIN0\_BLKBAR\_IND\_RIGHT\_START\_END 0x1266

Bit(s)	R/W	Default	Description
28-16	R	0	blkbar_ind_right_start.horizontal start of the right region in the current searching
12-0	R	0	blkbar_ind_right_end. horizontal end of the right region in the current searching



**Table 9-2063 VDIN0\_BLKBAR\_IND\_LEFT1\_CNT 0x1267**

Bit(s)	R/W	Default	Description
19-0	R	0	blkbar_ind_left1_cnt. Black pixel counter. left part of the left region

**Table 9-2064 VDIN0\_BLKBAR\_IND\_LEFT2\_CNT 0x1268**

Bit(s)	R/W	Default	Description
19-0	R	0	blkbar_ind_left2_cnt. Black pixel counter. right part of the left region

**Table 9-2065 VDIN0\_BLKBAR\_IND\_RIGHT1\_CNT 0x1269**

Bit(s)	R/W	Default	Description
19-0	R	0	blkbar_ind_right1_cnt. Black pixel counter. left part of the right region

**Table 9-2066 VDIN0\_BLKBAR\_IND\_RIGHT2\_CNT 0x126a**

Bit(s)	R/W	Default	Description
19-0	R	0	blkbar_ind_right2_cnt. Black pixel counter. right part of the right region

**Table 9-2067 VDIN0\_BLKBAR\_STATUS0 0x126b**

Bit(s)	R/W	Default	Description
29	R	0	blkbar_ind_black_det_done. LEFT/RIGHT Black detection done
28-16	R	0	blkbar_top_pos. Top black bar position
12-0	R	0	blkbar_bot_pos. Bottom black bar position

**Table 9-2068 VDIN0\_BLKBAR\_STATUS1 0x126c**

Bit(s)	R/W	Default	Description
28-16	R	0	blkbar_left_pos. Left black bar position
12-0	R	0	blkbar_right_pos. Right black bar position

**Table 9-2069 VDIN0\_WIN\_H\_START\_END 0x126d**

Bit(s)	R/W	Default	Description
28-16	R/W	0	input window H start
12-0	R/W	0	input window H end

**Table 9-2070 VDIN0\_WIN\_V\_START\_END 0x126e**

Bit(s)	R/W	Default	Description
28-16	R/W	0	input window V start
12-0	R/W	0	input window V end

**Table 9-2071 VDIN0\_ASFIFO\_CTRL3 0x126f**

Bit(s)	R/W	Default	Description
31	R/W	0	Vdi9 DE enable
30	R/W	0	Vdi9 go field enable
29	R/W	0	Vdi9 go line enable
28	R/W	0	Vdi9 if true, negative active input vsync
27	R/W	0	Vdi9 if true, negative active input hsync
26	R/W	0	Vdi9 vsync soft reset fifo enable
25	R/W	0	Vdi9 overflow status clear
24	R/W	0	Vdi9 asfifo soft reset, level signal
15	R/W	0	Vdi7 DE enable
14	R/W	0	Vdi7 go field enable
13	R/W	0	Vdi7 go line enable
12	R/W	0	Vdi7 if true, negative active input vsync
11	R/W	0	Vdi7 if true, negative active input hsync
10	R/W	0	Vdi7 vsync soft reset fifo enable
9	R/W	0	Vdi7 overflow status clear
8	R/W	0	Vdi7 asfifo soft reset, level signal
7	R/W	0	Vdi6 DE enable
6	R/W	0	Vdi6 go field enable
5	R/W	0	Vdi6 go line enable
4	R/W	0	Vdi6 if true, negative active input vsync
3	R/W	0	Vdi6 if true, negative active input hsync
2	R/W	0	Vdi6 vsync soft reset fifo enable
1	R/W	0	Vdi6 overflow status clear
0	R/W	0	Vdi6 asfifo soft reset, level signal

**Table 9-2072 VDIN0\_DOLBY\_DSC\_CTRL0 0x1275**

Bit(s)	R/W	Default	Description
31	R/W	0	Dolby check enable
30	R/W	0	Tunnel swap mode enable
29-24	R/W	0	Soft reset control, 29 : dsc, 28~27: crc check, 26~24, reserved

Bit(s)	R/W	Default	Description
16	R/W	0	Little endian mode
15-0	R/W	0	Monitor metadata position

**Table 9-2073 VDIN0\_DOLBY\_DSC\_CTRL1 0x1276**

Bit(s)	R/W	Default	Description
31-16	R/W	0	Metadata pixel start position
7-0	R/W	0	Crc check control

**Table 9-2074 VDIN0\_DOLBY\_DSC\_CTRL2 0x1277**

Bit(s)	R/W	Default	Description
31	R/W	0	Metadata read enable
30	R/W	0	Metadata read address auto-increment
29-20	R/W	0	Metadata sum
17-0	R/W	0	Tunnel mode channel selection

**Table 9-2075 VDIN0\_DOLBY\_DSC\_CTRL3 0x1278**

Bit(s)	R/W	Default	Description
15-0	R/W	0	Select metadata position

**Table 9-2076 VDIN0\_DOLBY\_AXI\_CTRL0 0x1279**

Bit(s)	R/W	Default	Description
31	R/W	0	Memory read enable
30	R/W	0	AXI bus read enable
29	R/W	0	AXI write channel urgent
28	R/W	0	Pack mode little endian
27	R/W	0	AXI bus soft reset
26	R/W	0	Frame reset enable
25	R/W	0	Memory read protection enable
24-16	R/W	0	Memory read sum
15-8	R/W	0	AXI request hold line
7-6	R/W	0	AXI burst length
5	R/W	0	Frame buffer start
4	R/W	0	Buffer start
3-2	R/W	0	AXI status monitor control
1-0	R/W	0	awid

Table 9-2077 VDIN0\_DOLBY\_AXI\_CTRL1 0x127a

Bit(s)	R/W	Default	Description
31-0	R/W	0	Buffer start address

Table 9-2078 VDIN0\_DOLBY\_AXI\_CTRL2 0x127b

Bit(s)	R/W	Default	Description
31-16	R/W	0	Buffer size
15-0	R/W	0	Frame buffer size

Table 9-2079 VDIN0\_DOLBY\_AXI\_CTRL3 0x127c

Bit(s)	R/W	Default	Description
7-0	R/W	0	Hold cycle

Table 9-2080 VDIN0\_WRARB\_MODE 0x12c0

Bit(s)	R/W	Default	Description
23:16	R/W	0	wrarb_sel : uns, default = 0 , wrarb_sel [0]==0 slave dc0 connect master port0 wrarb_sel[0]==1 slave dc0 connect master port1 wrarb_sel [1]==0 slave dc1 connect master port0 wrarb_sel[1]==1 slave dc1 connect master port1 wrarb_sel [2]==0 slave dc2 connect master port0 wrarb_sel[2]==1 slave dc2 connect master port1 wrarb_sel [3]==0 slave dc3 connect master port0 wrarb_sel[3]==1 slave dc3 connect master port1 wrarb_sel [4]==0 slave dc4 connect master port0 wrarb_sel[4]==1 slave dc3 connect master port1 wrarb_sel [5]==0 slave dc5 connect master port0 wrarb_sel[5]==1 slave dc3 connect master port1
8	R/W	0	wrarb_arb_mode : uns, default = 0 , wrarb_arb_mode[0] master port0 arb way,
1:0	R/W	0	wrarb_gate_clk_ctrl : uns, default = 0 , wrarb_gate_clk_ctrl[1:0] master port0 clk gate control

Table 9-2081 VDIN0\_WRARB\_REQEN\_SLV 0x12c1

Bit(s)	R/W	Default	Description
7:0	R/W	0	wrarb_dc_req_en : unsigned , default = 0 wrarb_dc_req_en [0]: the slv0 req to mst port0 enable, wrarb_dc_req_en [1]: the slv1 req to mst port0 enable, wrarb_dc_req_en [2]: the slv2 req to mst port0 enable, wrarb_dc_req_en [0]: the slv0 req to mst port1 enable, wrarb_dc_req_en [1]: the slv1 req to mst port1 enable, wrarb_dc_req_en [2]: the slv2 req to mst port1 enable,

Table 9-2082 VDIN0\_WRARB\_WEIGHT0\_SLV 0x12c2

Bit(s)	R/W	Default	Description
29:0	R/W	0	wrdc_weigh_sxn : unsigned , default = 0 wrdc_weigh_sxn [0*6+:6]: the slv0 req weigh number wrdc_weigh_sxn [1*6+:6]: the slv1 req weigh number wrdc_weigh_sxn [2*6+:6]: the slv2 req weigh number wrdc_weigh_sxn [3*6+:6]: the slv3 req weigh number wrdc_weigh_sxn [4*6+:6]: the slv4 req weigh number

Table 9-2083 VDIN0\_WRARB\_WEIGHT1\_SLV 0x12C3

Bit(s)	R/W	Default	Description
17:0	R/W	0	wrdc_weigh_sxn : unsigned , default = 0 the slv5 req weigh number [0*6+:6],the slv6 req weighnumber [1*6+:6],the slv7 req weighnumber [2*6+:6],

Table 9-2084 VDIN0\_RDWR\_ARB\_STATUS 0x12c4

Bit(s)	R/W	Default	Description
2	R.O	0	ro_wrarb_arb_busy : unsigned , default = 0
1	R/W	0x0	reserve :
0	R.O	0	ro_rdarb_arb_busy : unsigned , default = 0

Table 9-2085 VDIN0\_ARB\_DBG\_CTRL 0x12c5

Bit(s)	R/W	Default	Description
31:0	R.O	0	ro_det_cmd_ctrl : unsigned , default = 0

Table 9-2086 VDIN0\_ARB\_DBG\_STAT 0x12C6

Bit(s)	R/W	Default	Description
31:0	R.O	0	ro_det_dbg_stat : unsigned , default = 0

VDIN1\_SCALE\_COEF\_IDX 0x1300

VDIN1\_SCALE\_COEF 0x1301

Table 9-2087 VDIN1\_COM\_CTRL0 0x1302

Bit(s)	R/W	Default	Description
31	R/W	0	mpeg_to_vdin_sel, 0: mpeg source to NR directly, 1: mpeg source pass through here
30	R/W	0	mpeg_field info which can be written by software
29	R/W	0	force go_field, pulse signal
28	R/W	0	force go_line, pulse signal
27	R/W	0	enable mpeg_go_field input signal
26-20	R/W	0	hold lines
19	R/W	0	delay go_field function enable
18-12	R/W	0	delay go_field line number
11-10	R/W	0	component2 output switch, 00: select component0 in, 01: select component1 in, 10: select component2 in
9-8	R/W	0	component1 output switch, 00: select component0 in, 01: select component1 in, 10: select component2 in
7-6	R/W	0	component0 output switch, 00: select component0 in, 01: select component1 in, 10: select component2 in
5	R/W	0	input window selection function enable

Bit(s)	R/W	Default	Description
4	R/W	0	enable VDIN common data input, otherwise there will be no video data input
3-0	R/W	0	vdin selection, 1: mpeg_in from dram; 2: bt656 input; 3: Reserved (component input); 4: Reserved(tvdecoder input); 5: Reserved(hdmi rx input); 6: reserved(digital video input); 7: Wr_back 0; 8: reserved(MIPI CSI2); 9: Wr_back 1; 10: Reserved(second bt656 input); otherwise no input.

Table 9-2088 VDIN1\_ACTIVE\_MAX\_PIX\_CNT\_STATUS 0x1303

Bit(s)	R/W	Default	Description
28-16	R	0	active_max_pix_cnt, readonly
12-0	R	0	active_max_pix_cnt_shadow, readonly

Table 9-2089 VDIN1\_LCNT\_STATUS 0x1304

Bit(s)	R/W	Default	Description
28-16	R	0	go_line_cnt, readonly
12-0	R	0	active_line_cnt, readonly

Table 9-2090 VDIN1\_COM\_STATUS0 0x1305

Bit(s)	R/W	Default	Description
12-3	R	0	lfifo_buf_cnt
2	R	0	vdin_direct_done status
1	R	0	vdin_nr_done status
0	R	0	field

Table 9-2091 VDIN1\_COM\_STATUS1 0x1306

Bit(s)	R/W	Default	Description
31	R	0	vdi4 fifo overflow
29-24	R	0	vdi3_asfifo_cnt
23	R	0	vdi3 fifo overflow
21-16	R	0	vdi3_asfifo_cnt
15	R	0	vdi2 fifo overflow
13-8	R	0	vdi2_asfifo_cnt
7	R	0	vdi1 fifo overflow
5-0	R	0	vdi1_asfifo_cnt

**Table 9-2092 VDIN1\_LCNT\_SHADOW\_STATUS 0x1307**

Bit(s)	R/W	Default	Description
28-16	R	0	go_line_cnt_shadow, readonly
12-0	R	0	active_line_cnt_shadow, readonly

**Table 9-2093 VDIN1\_ASFIFO\_CTRL0 0x1308**

Bit(s)	R/W	Default	Description
23	R/W	0	vdi2 DE enable
22	R/W	0	vdi2 go field enable
21	R/W	0	vdi2 go line enable
20	R/W	0	vdi2 if true, negative active input vsync
19	R/W	0	vdi2 if true, negative active input hsync
18	R/W	0	vdi2 vsync soft reset fifo enable
17	R/W	0	vdi2 overflow status clear
16	R/W		vdi2 asfifo soft reset, level signal
7	R/W	0	Vdi1 DE enable
6	R/W	0	Vdi1 go field enable
5	R/W	0	Vdi1 go line enable
4	R/W	0	Vdi1 if true, negative active input vsync
3	R/W	0	Vdi1 if true, negative active input hsync
2	R/W	0	Vdi1 vsync soft reset fifo enable
1	R/W	0	Vdi1 overflow status clear
0	R/W	0	Vdi1 asfifo soft reset, level signal

**Table 9-2094 VDIN1\_ASFIFO\_CTRL1 0x1309**

Bit(s)	R/W	Default	Description
23	R/W	0	Vdi4 DE enable
22	R/W	0	Vdi4 go field enable
21	R/W	0	Vdi4 go line enable
20	R/W	0	Vdi4 if true, negative active input vsync
19	R/W	0	Vdi4 if true, negative active input hsync
18	R/W	0	Vdi4 vsync soft reset fifo enable
17	R/W	0	Vdi4 overflow status clear
16	R/W	0	Vdi4 asfifo soft reset, level signal
7	R/W	0	Vdi3 DE enable
6	R/W	0	Vdi3 go field enable
5	R/W	0	Vdi3 go line enable

Bit(s)	R/W	Default	Description
4	R/W	0	Vdi3 if true, negative active input vsync
3	R/W	0	Vdi3 if true, negative active input hsync
2	R/W	0	Vdi3 vsync soft reset fifo enable
1	R/W	0	Vdi3 overflow status clear
0	R/W	0	Vdi3 asfifo soft reset, level signal

Table 9-2095 VDIN1\_WIDTHM1I\_WIDTHM1O 0x130a

Bit(s)	R/W	Default	Description
28-16	R/W	0	input width minus 1, after the window function
12-0	R/W	0	output width minus 1

Table 9-2096 VDIN1\_SC\_MISC\_CTRL 0x130b

Bit(s)	R/W	Default	Description
14-8	R/W	0	hsc_ini_pixi_ptr, signed data, only useful when short_lineo_en is true
7	R/W	0	prehsc_en
6	R/W	0	hsc_en
5	R/W	0	hsc_short_lineo_en, short line output enable
4	R/W	0	hsc_nearest_en
3	R/W	0	Hsc_phase0_always_en
3	R/W	0	phase0_always_en
2-0	R/W	0	hsc_bank_length

Table 9-2097 VDIN1\_HSC\_PHASE\_STEP 0x130c

Bit(s)	R/W	Default	Description
28-24	R/W	0	integer portion
23-0	R/W	0	fraction portion

Table 9-2098 VDIN1\_HSC\_INI\_CTRL 0x130d

Bit(s)	R/W	Default	Description
30-29	R/W	0	hscale rpt_p0_num
28-24	R/W	0	hscale ini_rcv_num
23-0	R/W	0	hscale ini_phase



**Table 9-2099 VDIN1\_COM\_STATUS2 0x130e**

Bit(s)	R/W	Default	Description
23	R	0	Vdi7 fifo overflow
21-16	R	0	Vdi7_asfifo_cnt
15	R	0	Vdi6 fifo overflow
13-8	R	0	Vdi6_asfifo_cnt
7	R	0	vdi5 fifo overflow
5-0	R	0	vdi5_asfifo_cnt

**Table 9-2100 VDIN1\_ASFIFO\_CTRL2 0x130f**

Bit(s)	R/W	Default	Description
25	R/W	0	if true, decimation counter sync with first valid DE in the field, //otherwise the decimation counter is not sync with external signal
24	R/W	0	decimation de enable
23-20	R/W	0	decimation phase, which counter value use to decimate,
19-16	R/W	0	decimation number, 0: not decimation, 1: decimation 2, 2: decimation 3 ....
7	R/W	0	Vdi5 DE enable
6	R/W	0	Vdi5 go field enable
5	R/W	0	Vdi5 go line enable
4	R/W	0	Vdi5 if true, negative active input vsync
3	R/W	0	Vdi5 if true, negative active input hsync
2	R/W	0	Vdi5 vsync soft reset fifo enable
1	R/W	0	Vdi5 overflow status clear
0	R/W	0	Vdi5 asfifo soft reset, level signal

**Table 9-2101 VDIN1\_MATRIX\_CTRL 0x1310**

Bit(s)	R/W	Default	Description
0	R/W	0	post conversion matrix enable

**Table 9-2102 VDIN1\_MATRIX\_COEF00\_01 0x1311**

Bit(s)	R/W	Default	Description
28-16	R/W	0	coef00
12-0	R/W	0	coef01

**Table 9-2103 VDIN1\_MATRIX\_COEF02\_10 0x1312**

Bit(s)	R/W	Default	Description
28-16	R/W	0	coef02
12-0	R/W	0	Coef10

**Table 9-2104 VDIN1\_MATRIX\_COEF11\_12 0x1313**

Bit(s)	R/W	Default	Description
28-16	R/W	0	Coef11
12-0	R/W	0	Coef12

**Table 9-2105 VDIN1\_MATRIX\_COEF20\_21 0x1314**

Bit(s)	R/W	Default	Description
28-16	R/W	0	Coef20
12-0	R/W	0	coef21

**Table 9-2106 VDIN1\_ 0x1315**

Bit(s)	R/W	Default	Description
18-16	R/W	0	convrs
7-0	R/W	0	Coef22

**Table 9-2107 VDIN1\_MATRIX\_OFFSET0\_1 0x1316**

Bit(s)	R/W	Default	Description
26-16	R/W	0	offset0
10-0	R/W	0	Offset1

**Table 9-2108 VDIN1\_MATRIX\_OFFSET2 0x1317**

Bit(s)	R/W	Default	Description
10-0	R/W	0	Offset2

**Table 9-2109 VDIN1\_MATRIX\_PRE\_OFFSET0\_1 0x1318**

Bit(s)	R/W	Default	Description
26-16	R/W	0	Pre_offset0
10-0	R/W	0	Pre_Offset1

**Table 9-2110 VDIN1\_MATRIX\_PRE\_OFFSET2 0x1319**

Bit(s)	R/W	Default	Description
10-0	R/W	0	Pre_Offset2

**Table 9-2111 VDIN1\_LFIFO\_CTRL 0x131a**

Bit(s)	R/W	Default	Description
11-0	R/W	0	lfifo_buf_size

**Table 9-2112 VDIN1\_COM\_GCLK\_CTRL 0x131b**

Bit(s)	R/W	Default	Description
15-14	R/W	0	Gate clock control for blackbar detector
13-12	R/W	0	Gate clock control for hist
11-10	R/W	0	Gate clock control for line fifo
9-8	R/W	0	Gate clock control for matrix
7-6	R/W	0	Gate clock control for horizontal scaler
5-4	R/W	0	Gate clock control for pre scaler
3-2	R/W	0	Gate clock control for vdin_com_proc
1-0	R/W	0	Gate clock control for the vdin reg

**Table 9-2113 VDIN1\_INTF\_WIDTHM1 0x131c**

Bit(s)	R/W	Default	Description
26	R/W	0	VDIN write mif bvalid_sel: 1. Bvalid_signal from bus, 0: bytes_wr handshakes
25	R/W	0	VDIN write mif burst last sel: 1. All kind of burst last signal include ext_data_last. 0. Used the normal burst last signal
12-0	R/W	0	VDIN input interface width minus 1, before the window function, after the de decimation

**Table 9-2114 VDIN1\_WR\_CTRL2 0x131f**

Bit(s)	R/W	Default	Description
19	R/W	0	Vdin1 wr bit10 mode
18	R/W	0	Data_ext_en 1: send out data if req was interrupt by soft reset 0 : normal mode
17:16	R/W	1	Words_lim[1:0]: it would not send out request before Words_lim *16 words were ready
15:12	R/W	1	Burst_lim : 00 , 1 word in 1burst , 01 ,2 words in 1burst, 10, 4 words in 1burst , 11 reserved
10:9	R/W	0	Words_lim[3:2]
8	R/W	0	1: discard data before line fifo, 0: normal mode
7-0	R/W	0	Write chroma canvas address, for NV12/21 mode.

Table 9-2115 VDIN1\_WR\_CTRL 0x1320

Bit(s)	R/W	Default	Description
31-30	R/W	0	vdin1_wr_mif_hconv_mode. Applicable only to vdin_write_format=0 or 2. 0=Output every even pixel's CbCr; 1=Output every odd pixel's CbCr; 2=Output an average value per even&odd pair of pixels; 3=Output all CbCr. Only applies to vdin_write_format =2.
29	R/W	0	vdin1_wr_mif_no_clk_gate. If true, enable free-run clock.
28	R/W	0	clear write response counter in the vdin write memory interface
27	R/W	1	eol_sel, 1: use eol as the line end indication, 0: use width as line end indication in the vdin write memory interface
23	R/W	1	vdin frame reset enable, if true, it will provide frame reset during go_field(vsync) to the modules after that
22	R/W	1	vdin line fifo soft reset enable, meaning, if true line fifo will reset during go_field (vsync)
21	R/W	0	vdin direct write done status clear bit
20	R/W	0	vdin NR write done status clear bit
19	R/W	0	Vdin0_wr words swap : swap the 2 64bits word in 128 words
18	R/W	0	vdin1_wr_mif_swap_cbcr. Applicable only to vdin_write_format =2. 0=Output CbCr (NV12); 1=Output CrCb (NV21);
17:16	R/W	0	vdin1_wr_mif_vconv_mode. Applicable only to vdin_write_format=2. 0=Output every even line's CbCr; 1=Output every odd line's CbCr; 2=Reserved; 3=Output all CbCr.
13-12	R/W	0	vdin_write_format, 0: 4:2:2 to one canvas; 1: 4:4:4 to one canvas; 2: Y to luma canvas, CbCr to chroma canvas, for NV12/21; 3: 422 10 bit full pack mode
11	R/W	0	vdin write canvas double buffer enable, means the canvas address will be latched by vsync before using
9	R/W	0	vdin write request urgent
8	R/W	0	vdin write request enable
7-0	R/W	0	Write canvas address (For NV12/21 mode, it's LUMA canvas)

Table 9-2116 VDIN1\_WR\_H\_START\_END 0x1321

Bit(s)	R/W	Default	Description
27-16	R/W	0	start
11-0	R/W	0	end

Table 9-2117 VDIN1\_WR\_V\_START\_END 0x1322

Bit(s)	R/W	Default	Description
27-16	R/W	0	start
11-0	R/W	0	end

**Table 9-2118 VDIN1\_VSC\_PHASE\_STEP 0x1323**

Bit(s)	R/W	Default	Description
24-16	R/W	0	integer portion
19-0	R/W	0	fraction portion

**Table 9-2119 VDIN1\_VSC\_INI\_CTRL 0x1324**

Bit(s)	R/W	Default	Description
23	R/W	0	vsc_en, vertical scaler enable
21	R/W	0	vsc_phase0_always_en, when scale up, you have to set it to 1
20-16	R/W	0	ini skip_line_num
15-0	R/W	0	vscaler ini_phase

**Table 9-2120 VDIN1\_SCIN\_HEIGHTM1 0x1325**

Bit(s)	R/W	Default	Description
12-0	R/W	0x437	scaler input height minus 1

**Table 9-2121 VDIN1\_DUMMY\_DATA 0x1326**

Bit(s)	R/W	Default	Description
23-16	R/W	0	dummy component 0
15-8	R/W	0x80	dummy component 1
7-0	R/W	0x80	dummy component 2

**Table 9-2122 VDIN1\_MATRIX\_PROBE\_COLOR 0x1328**

Bit(s)	R/W	Default	Description
29-20	R/W	0	component 0
19-10	R/W	0	component 1
9-0	R/W	0	component 2

**Table 9-2123 VDIN1\_MATRIX\_HL\_COLOR 0x1329**

Bit(s)	R/W	Default	Description
23-16	R/W	0	component 0
15-8	R/W	0	component 1
7-0	R/W	0	component 2

**Table 9-2124 VDIN1\_MATRIX\_PROBE\_POS 0x132a**

Bit(s)	R/W	Default	Description
28-16	R/W	0	probe x, position
12-0	R/W	0	probe y, position

**Table 9-2125 VDIN1\_HIST\_CTRL 0x1330**

Bit(s)	R/W	Default	Description
31-24	R/W	0	Hist pixel white threshold, larger than this will be counted as white pixel number
23-16	R/W	0	Hist pixel black threshold, less than this will be counted as black pixel number
11	R/W	0	Hist 32bin only mode
10-9	R/W	0	ldim_stts_din_sel, 00: from matrix0 dout, 01: from vsc_dout, 10: from matrix1 dout, 11: from matrix1 din
8	R/W	0	ldim_stts_en
6-5	R/W	0	hist_dnlp_low the real pixels in each bins got by VDIN_DNLP_HISTXX should multiple with $2^{(dnlp\_low+3)}$
3-2	R/W	0	hist_din_sel the source used for hist statistics. 2'b00: from MAT0_dout; 2'b01: from vsc_dout; 2'b10: from mat1_dout, 3: mat1_din
1	R/W	0	hist_win_en 1'b0: hist used for full picture; 1'b1: hist used for pixels within hist window
0	R/W	0	hist_spl_en 1'b0: disable hist readback; 1'b1: enable hist readback

**Table 9-2126 VDIN1\_HIST\_H\_START\_END 0x1331**

Bit(s)	R/W	Default	Description
28-16	R/W	0	hist_hstart horizontal start value to define hist window
12-0	R/W	0	hist_hend horizontal end value to define hist window

**Table 9-2127 VDIN1\_HIST\_V\_START\_END 0x1332**

Bit(s)	R/W	Default	Description
28-16	R/W	0	hist_vstart vertical start value to define hist window
12-0	R/W	0	hist_vend vertical end value to define hist window

**Table 9-2128 VDIN1\_HIST\_MAX\_MIN 0x1333**

Bit(s)	R/W	Default	Description
15-8	R	0	hist_max maximum value
7-0	R	0	hist_min minimum value

**Table 9-2129 VDIN1\_HIST\_SPL\_VAL 0x1334**

Bit(s)	R/W	Default	Description
31-0	R	0	hist_spl_rd , counts for the total luma value

**Table 9-2130 VDIN1\_HIST\_SPL\_PIX\_CNT 0x1335**

Bit(s)	R/W	Default	Description
21-0	R	0	hist_spl_pixel_count, counts for the total calculated pixels

**Table 9-2131 VDIN1\_HIST\_CHROMA\_SUM 0x1336**

Bit(s)	R/W	Default	Description
31-0	R	0	hist_chroma_sum , counts for the total chroma value

//0-255 are splitted to 64 bins evenly, and VDIN\_DNLP\_HISTXX

//are the statistic number of pixels that within each bin.

**Table 9-2132 VDIN1\_DNLP\_HIST00 0x1337**

Bit(s)	R/W	Default	Description
31-16	R	0	counts for the 2nd bin
15-0	R	0	counts for the 1st bin

**Table 9-2133 VDIN1\_DNLP\_HIST01 0x1338**

Bit(s)	R/W	Default	Description
31-16	R	0	counts for the 4th bin
15-0	R	0	counts for the 3rd bin

**Table 9-2134 VDIN1\_DNLP\_HIST02 0x1339**

Bit(s)	R/W	Default	Description
31-16	R	0	counts for the 6th bin
15-0	R	0	counts for the 5th bin

**Table 9-2135 VDIN1\_DNLP\_HIST03 0x133a**

Bit(s)	R/W	Default	Description
31-16	R	0	counts for the 8th bin
15-0	R	0	counts for the 7th bin

**Table 9-2136 VDIN1\_DNLP\_HIST04 0x133b**

Bit(s)	R/W	Default	Description
31-16	R	0	counts for the 10th bin
15-0	R	0	counts for the 9th bin

**Table 9-2137 VDIN1\_DNLP\_HIST05 0x133c**

Bit(s)	R/W	Default	Description
31-16	R	0	counts for the 12th bin
15-0	R	0	counts for the 11th bin

**Table 9-2138 VDIN1\_DNLP\_HIST06 0x133d**

Bit(s)	R/W	Default	Description
31-16	R	0	counts for the 14th bin
15-0	R	0	counts for the 13th bin

**Table 9-2139 VDIN1\_DNLP\_HIST07 0x133e**

Bit(s)	R/W	Default	Description
31-16	R	0	counts for the 16th bin
15-0	R	0	counts for the 15th bin

**Table 9-2140 VDIN1\_DNLP\_HIST08 0x133f**

Bit(s)	R/W	Default	Description
31-16	R	0	counts for the 18th bin
15-0	R	0	counts for the 17th bin

**Table 9-2141 VDIN1\_DNLP\_HIST09 0x1340**

Bit(s)	R/W	Default	Description
31-16	R	0	counts for the 20th bin
15-0	R	0	counts for the 19th bin

**Table 9-2142 VDIN1\_DNLP\_HIST10 0x1341**

Bit(s)	R/W	Default	Description
31-16	R	0	counts for the 22nd bin
15-0	R	0	counts for the 21st bin



**Table 9-2143 VDIN1\_DNLP\_HIST11 0x1342**

Bit(s)	R/W	Default	Description
31-16	R	0	counts for the 24th bin
15-0	R	0	counts for the 23rd bin

**Table 9-2144 VDIN1\_DNLP\_HIST12 0x1343**

Bit(s)	R/W	Default	Description
31-16	R	0	counts for the 26th bin
15-0	R	0	counts for the 25th bin

**Table 9-2145 VDIN1\_DNLP\_HIST13 0x1344**

Bit(s)	R/W	Default	Description
31-16	R	0	counts for the 28th bin
15-0	R	0	counts for the 27th bin

**Table 9-2146 VDIN1\_DNLP\_HIST14 0x1345**

Bit(s)	R/W	Default	Description
31-16	R	0	counts for the 30th bin
15-0	R	0	counts for the 29th bin

**Table 9-2147 VDIN1\_DNLP\_HIST15 0x1346**

Bit(s)	R/W	Default	Description
31-16	R	0	counts for the 32nd bin
15-0	R	0	counts for the 31st bin

**Table 9-2148 VDIN1\_DNLP\_HIST16 0x1347**

Bit(s)	R/W	Default	Description
31-16	R	0	counts for the 34th bin
15-0	R	0	counts for the 33rd bin

**Table 9-2149 VDIN1\_DNLP\_HIST17 0x1348**

Bit(s)	R/W	Default	Description
31-16	R	0	counts for the 36th bin
15-0	R	0	counts for the 35th bin

**Table 9-2150 VDIN1\_DNLP\_HIST18 0x1349**

Bit(s)	R/W	Default	Description
31-16	R	0	counts for the 38th bin
15-0	R	0	counts for the 37th bin

**Table 9-2151 VDIN1\_DNLP\_HIST19 0x134a**

Bit(s)	R/W	Default	Description
31-16	R	0	counts for the 40th bin
15-0	R	0	counts for the 39th bin

**Table 9-2152 VDIN1\_DNLP\_HIST20 0x134b**

Bit(s)	R/W	Default	Description
31-16	R	0	counts for the 42nd bin
15-0	R	0	counts for the 41st bin

**Table 9-2153 VDIN1\_DNLP\_HIST21 0x134c**

Bit(s)	R/W	Default	Description
31-16	R	0	counts for the 44th bin
15-0	R	0	counts for the 43rd bin

**Table 9-2154 VDIN1\_DNLP\_HIST22 0x134d**

Bit(s)	R/W	Default	Description
31-16	R	0	counts for the 46th bin
15-0	R	0	counts for the 45th bin

**Table 9-2155 VDIN1\_DNLP\_HIST23 0x134e**

Bit(s)	R/W	Default	Description
31-16	R	0	counts for the 48th bin
15-0	R	0	counts for the 47th bin

**Table 9-2156 VDIN1\_DNLP\_HIST24 0x134f**

Bit(s)	R/W	Default	Description
31-16	R	0	counts for the 50th bin
15-0	R	0	counts for the 49th bin

**Table 9-2157 VDIN1\_DNLP\_HIST25 0x1350**

Bit(s)	R/W	Default	Description
31-16	R	0	counts for the 52nd bin
15-0	R	0	counts for the 51st bin

**Table 9-2158 VDIN1\_DNLP\_HIST26 0x1351**

Bit(s)	R/W	Default	Description
31-16	R	0	counts for the 54th bin
15-0	R	0	counts for the 53rd bin

**Table 9-2159 VDIN1\_DNLP\_HIST27 0x1352**

Bit(s)	R/W	Default	Description
31-16	R	0	counts for the 56th bin
15-0	R	0	counts for the 55th bin

**Table 9-2160 VDIN1\_DNLP\_HIST28 0x1353**

Bit(s)	R/W	Default	Description
31-16	R	0	counts for the 58th bin
15-0	R	0	counts for the 57th bin

**Table 9-2161 VDIN1\_DNLP\_HIST29 0x1354**

Bit(s)	R/W	Default	Description
31-16	R	0	counts for the 60th bin
15-0	R	0	counts for the 59th bin

**Table 9-2162 VDIN1\_DNLP\_HIST30 0x1355**

Bit(s)	R/W	Default	Description
31-16	R	0	counts for the 62nd bin
15-0	R	0	counts for the 61st bin

**Table 9-2163 VDIN1\_DNLP\_HIST31 0x1356**

Bit(s)	R/W	Default	Description
31-16	R	0	counts for the 64th bin
15-0	R	0	counts for the 63rd bin

Table 9-2164 VDIN1\_LDIM\_STTS\_HIST\_REGION\_IDX 0x1357

Bit(s)	R/W	Default	Description
31	R	0	local dimming max statistic enable
28	R	0	eol enable
27-25	R	0	vertical line overlap number for max finding
24-22	R	0	horizontal pixel overlap number, 0: 17 pix, 1: 9 pix, 2: 5 pix, 3: 3 pix, 4: 0 pix
20	R	0	1,2,1 low pass filter enable before max/hist statistic
19-16	R	0	region H/V position index, refer to VDIN_LDIM_STTS_HIST_SET_REGION
15	R	0	1: region read index auto increase per read to VDIN_LDIM_STTS_HIST_READ_REGION
6-0	R	0	region read index

Table 9-2165 VDIN1\_LDIM\_STTS\_HIST\_SET\_REGION 0x1358

Bit(s)	R/W	Default	Description
28:16	R	0	if VDIN_LDIM_STTS_HIST_REGION_IDX[19:16] == 5'h0: read/write hvstart0 if VDIN_LDIM_STTS_HIST_REGION_IDX[19:16] == 5'h1: read/write hend01 if VDIN_LDIM_STTS_HIST_REGION_IDX[19:16] == 5'h2: read/write vend01 if VDIN_LDIM_STTS_HIST_REGION_IDX[19:16] == 5'h3: read/write hend23 if VDIN_LDIM_STTS_HIST_REGION_IDX[19:16] == 5'h4: read/write vend23 if VDIN_LDIM_STTS_HIST_REGION_IDX[19:16] == 5'h5: read/write hend45 if VDIN_LDIM_STTS_HIST_REGION_IDX[19:16] == 5'h6: read/write vend45 if VDIN_LDIM_STTS_HIST_REGION_IDX[19:16] == 5'd7: read/write hend67 if VDIN_LDIM_STTS_HIST_REGION_IDX[19:16] == 5'h8: read/write vend67 if VDIN_LDIM_STTS_HIST_REGION_IDX[19:16] == 5'h9: read/write hend89 if VDIN_LDIM_STTS_HIST_REGION_IDX[19:16] == 5'ha: read/write vend89 //hvstart0, Bit 28:16 row0 vstart, Bit 12:0 col0 hstart //hend01, Bit 28:16 col1 hend, Bit 12:0 col0 hend //vend01, Bit 28:16 row1 vend, Bit 12:0 row0 vend //hend23, Bit 28:16 col3 hend, Bit 12:0 col2 hend //vend23, Bit 28:16 row3 vend, Bit 12:0 row2 vend //hend45, Bit 28:16 col5 hend, Bit 12:0 col4 hend //vend45, Bit 28:16 row5 vend, Bit 12:0 row4 vend //hend67, Bit 28:16 col7 hend, Bit 12:0 col6 hend //vend67, Bit 28:16 row7 vend, Bit 12:0 row6 vend //hend89, Bit 28:16 col9 hend, Bit 12:0 col8 hend //vend89, Bit 28:16 row9 vend, Bit 12:0 row8 vend
12:0	R	0	

Table 9-2166 VDIN1\_LDIM\_STTS\_HIST\_READ\_REGION 0x1359

Bit(s)	R/W	Default	Description
29:20	R	0	Max_comp2
19:10	R	0	Max_comp1
9:0	R	0	Max_comp0

Table 9-2167 VDIN1\_MEAS\_CTRL0 0x135a

Bit(s)	R/W	Default	Description
18	R/W	0	reset bit, high active
17	R/W	0	if true, widen hs/vs pulse
16	R/W	0	vsync total counter always accumulating enable

Bit(s)	R/W	Default	Description
14-12	R/W	0	select hs/vs of video input channel to measure, 0: no selection, 1: vdi1, 2: vid2: 3: vid3, 4:vid4, 5:vdi5, 6:vdi6, 7:vdi7, 8:vdi8, 9:vdi9.
11-4	R/W	0	vsync_span, define how many vsync span need to measure
2-0	R/W	0	meas_hs_index, index to select which HS counter/range

Table 9-2168 VDIN1\_MEAS\_VS\_COUNT\_HI 0x135b

Bit(s)	R/W	Default	Description
19-16	R	0	meas_ind_total_count_n, every number of sync_span vsyncs, this count add 1
15-0	R	0	high bit portion of vsync total counter

Table 9-2169 VDIN1\_MEAS\_VS\_COUNT\_LO 0x135c

Bit(s)	R/W	Default	Description
31-0	R	0	low bit portion of vsync total counter

VDIN1\_MEAS\_HS\_RANGE 0x135d

//according to the meas\_hs\_index in register VDIN\_MEAS\_CTRL0

//meas\_hs\_index == 0, first hs range

//meas\_hs\_index == 1, second hs range

//meas\_hs\_index == 2, third hs range

//meas\_hs\_index == 3, fourth hs range

Bit(s)	R/W	Default	Description
28-16	R	0	count_start
12-0	R	0	count_end

VDIN1\_MEAS\_HS\_COUNT 0x135e

//according to the meas\_hs\_index in register VDIN\_MEAS\_CTRL0,

//meas\_hs\_index == 0, first range hs counter,

//meas\_hs\_index == 1, second range hs

//meas\_hs\_index == 2, third range hs

//meas\_hs\_index == 3, fourth range hs

Bit(s)	R/W	Default	Description
23-0	R	0	Hs counter

**Table 9-2170 VDIN1\_BLKBAR\_CTRL1 0x135f**

Bit(s)	R/W	Default	Description
8	R/W	0	white_enable
7-0	R/W	0	blkbar_white_level

**Table 9-2171 VDIN1\_BLKBAR\_CTRL0 0x1360**

Bit(s)	R/W	Default	Description
31-24	R/W	0	blkbar_black_level threshold to judge a black point
20-8	R/W	0	blkbar_hwidth left and right region width
7-5	R/W	0	blkbar_comp_sel select yin or uin or vin to be the valid input
4	R/W	0	blkbar_sw_statistic_en enable software statistic of each block black points number
3	R/W	0	blkbar_det_en
2-1	R/W	0	blkbar_din_sel
0	R/W	0	Blkbar_det_top_en

**Table 9-2172 VDIN1\_BLKBAR\_H\_START\_END 0x1361**

Bit(s)	R/W	Default	Description
28-16	R/W	0	blkbar_hstart. Left region start
12-0	R/W	0	blkbar_hend. Right region end

**Table 9-2173 VDIN1\_BLKBAR\_V\_START\_END 0x1362**

Bit(s)	R/W	Default	Description
28-16	R/W	0	blkbar_vstart.
12-0	R/W	0	blkbar_vend.

**Table 9-2174 VDIN1\_BLKBAR\_CNT\_THRESHOLD 0x1363**

Bit(s)	R/W	Default	Description
19-0	R/W	0	blkbar_cnt_threshold. threshold to judge whether a block is totally black

**Table 9-2175 VDIN1\_BLKBAR\_ROW\_TH1\_TH2 0x1364**

Bit(s)	R/W	Default	Description
28-16	R/W	0	blkbar_row_th1. //threshold of the top blackbar
12-0	R/W	0	blkbar_row_th2 //threshold of the bottom blackbar

**Table 9-2176 VDIN1\_BLKBAR\_IND\_LEFT\_START\_END 0x1365**

Bit(s)	R/W	Default	Description
28-16	R	0	blkbar_ind_left_start. horizontal start of the left region in the current searching
12-0	R	0	blkbar_ind_left_end. horizontal end of the left region in the current searching

**Table 9-2177 VDIN1\_BLKBAR\_IND\_RIGHT\_START\_END 0x1366**

Bit(s)	R/W	Default	Description
28-16	R	0	blkbar_ind_right_start. horizontal start of the right region in the current searching
12-0	R	0	blkbar_ind_right_end. horizontal end of the right region in the current searching

**Table 9-2178 VDIN1\_BLKBAR\_IND\_LEFT1\_CNT 0x1367**

Bit(s)	R/W	Default	Description
19-0	R	0	blkbar_ind_left1_cnt. Black pixel counter. left part of the left region

**Table 9-2179 VDIN1\_BLKBAR\_IND\_LEFT2\_CNT 0x1368**

Bit(s)	R/W	Default	Description
19-0	R	0	blkbar_ind_left2_cnt. Black pixel counter. right part of the left region

**Table 9-2180 VDIN1\_BLKBAR\_IND\_RIGHT1\_CNT 0x1369**

Bit(s)	R/W	Default	Description
19-0	R	0	blkbar_ind_right1_cnt. Black pixel counter. left part of the right region

**Table 9-2181 VDIN1\_BLKBAR\_IND\_RIGHT2\_CNT 0x136a**

Bit(s)	R/W	Default	Description
19-0	R	0	blkbar_ind_right2_cnt. Black pixel counter. right part of the right region

**Table 9-2182 VDIN1\_BLKBAR\_STATUS0 0x136b**

Bit(s)	R/W	Default	Description
29	R	0	blkbar_ind_black_det_done. LEFT/RIGHT Black detection done
28-16	R	0	blkbar_top_pos. Top black bar position
12-0	R	0	blkbar_bot_pos. Bottom black bar position

**Table 9-2183 VDIN1\_BLKBAR\_STATUS1 0x136c**

Bit(s)	R/W	Default	Description
28-16	R	0	blkbar_left_pos. Left black bar posiont
12-0	R	0	blkbar_right_pos. Right black bar position

**Table 9-2184 VDIN1\_WIN\_H\_START\_END 0x136d**

Bit(s)	R/W	Default	Description
28-16	R/W	0	input window H start
12-0	R/W	0	input window H end

**Table 9-2185 VDIN1\_WIN\_V\_START\_END 0x136e**

Bit(s)	R/W	Default	Description
28-16	R/W	0	input window V start
12-0	R/W	0	input window V end

**Table 9-2186 VDIN1\_ASFIFO\_CTRL3 0x136f**

Bit(s)	R/W	Default	Description
15	R/W	0	Vdi7 DE enable
14	R/W	0	Vdi7 go field enable
13	R/W	0	Vdi7 go line enable
12	R/W	0	Vdi7 if true, negative active input vsync
11	R/W	0	Vdi7 if true, negative active input hsync
10	R/W	0	Vdi7 vsync soft reset fifo enable
9	R/W	0	Vdi7 overflow status clear
8	R/W	0	Vdi7 asfifo soft reset, level signal
7	R/W	0	Vdi6 DE enable
6	R/W	0	Vdi6 go field enable
5	R/W	0	Vdi6 go line enable
4	R/W	0	Vdi6 if true, negative active input vsync
3	R/W	0	Vdi6 if true, negative active input hsync
2	R/W	0	Vdi6 vsync soft reset fifo enable
1	R/W	0	Vdi6 overflow status clear
0	R/W	0	Vdi6 asfifo soft reset, level signal



**Table 9-2187 VDIN1\_COM\_GCLK\_CTRL2 0x1370**

Bit(s)	R/W	Default	Description
3-2	R/W	0	Vshrk_clk2 ctrl
1-0	R/W	0	Vshrk_clk1 ctrl

**Table 9-2188 VDIN1\_VSHRK\_CTRL 0x1371**

Bit(s)	R/W	Default	Description
27	R/W	0	Vshrk enable
26:25	R/W	0	Vshrk mode, 0: 1/2 shrink, 1: 1/4 shrink, 2: 1/8 shrink
24	R/W	0	Vshrink lpf mode, 1: 0.5,1.5,1.5,0.5 lpf for 1/4 shrink, 0.5,1.5,1.5...for 1/8 shrink
23:0	R/W	0	Vshrink padding dummy data

**Table 9-2189 VDIN1\_HIST32 0x1372**

Bit(s)	R/W	Default	Description
31:0	R	0	Hist 32 mode, [31:16] for white pixel number, 15:0 for black pixel number

**Table 9-2190 VDIN1\_COM\_STATUS3 0x1373**

Bit(s)	R/W	Default	Description
7	R	0	Vdi9 fifo overflow
5:0	R	0	Vdi9 asfifo cnt

**Table 9-2191 VI\_HIST\_CTRL 0x2e00**

Bit(s)	R/W	Default	Description
17-16	R/W	0	Spl_sft: the splt are right shift by spl_sft, 0: no shift, 1: right shift by 1, 2,3...
14	R/W	0	Hist_34bin_only, bin 32~63 are not valid, there are 34bins, bin0~bin31, and bin 64 for black pixel, bin 65 for white pixel
13-11	R/W	0	Hist_in_sel: 0: vpp_dout, 1: vpp_vd1_din, 2: vpp_vd2_din, 3: osd1, 4:osd2 5: di pre 6: vdin 7: post blend
10-8	R/W	0	Hist_din_comp_mux: mux of each component, din[9:0],[19:10],[29:20] switches
7-5	R/W	0	Hist_dnlp_low: hist number are shift by (hist_dnlp_low + 3). I.e. Dnlp_low =0, >> 3, dnlp_low=1, >> 4
1	R/W	0	Hist_win_en: hist statistic in a window
0	R/W	0	Luma_hist_spl_en, 1: enable the histogram statistic

Table 9-2192 VDIN1\_WRARB\_MODE 0x13c0

Bit(s)	R/W	Default	Description
23:16	R/W	0	wrarb_sel : uns, default = 0 , wrarb_sel [0]==0 slave dc0 connect master port0 wrarb_sel[0]==1 slave dc0 connect master port1 wrarb_sel [1]==0 slave dc1 connect master port0 wrarb_sel[1]==1 slave dc1 connect master port1 wrarb_sel [2]==0 slave dc2 connect master port0 wrarb_sel[2]==1 slave dc2 connect master port1 wrarb_sel [3]==0 slave dc3 connect master port0 wrarb_sel[3]==1 slave dc3 connect master port1 wrarb_sel [4]==0 slave dc4 connect master port0 wrarb_sel[4]==1 slave dc4 connect master port1 wrarb_sel [5]==0 slave dc5 connect master port0 wrarb_sel[5]==1 slave dc5 connect master port1
8	R/W	0	wrarb_arb_mode : uns, default = 0 , wrarb_arb_mode[0] master port0 arb way,
1:0	R/W	0	wrarb_gate_clk_ctrl : uns, default = 0 , wrarb_gate_clk_ctrl[1:0] master port0 clk gate control

Table 9-2193 VDIN1\_WRARB\_REQEN\_SLV 0x13c1

Bit(s)	R/W	Default	Description
7:0	R/W	0	wrarb_dc_req_en : unsigned , default = 0 wrarb_dc_req_en [0]: the slv0 req to mst port0 enable, wrarb_dc_req_en [1]: the slv1 req to mst port0 enable, wrarb_dc_req_en [2]: the slv2 req to mst port0 enable, wrarb_dc_req_en [0]: the slv0 req to mst port1 enable, wrarb_dc_req_en [1]: the slv1 req to mst port1 enable, wrarb_dc_req_en [2]: the slv2 req to mst port1 enable,

Table 9-2194 VDIN1\_WRARB\_WEIGHT0\_SLV 0x13C2

Bit(s)	R/W	Default	Description
29:0	R/W	0	wrdc_weigh_sxn : unsigned , default = 0 wrdc_weigh_sxn [0*6+:6]: the slv0 req weigh number wrdc_weigh_sxn [1*6+:6]: the slv1 req weigh number wrdc_weigh_sxn [2*6+:6]: the slv2 req weigh number wrdc_weigh_sxn [3*6+:6]: the slv3 req weigh number wrdc_weigh_sxn [4*6+:6]: the slv4 req weigh number

Table 9-2195 VDIN1\_WRARB\_WEIGHT1\_SLV 0x13C3

Bit(s)	R/W	Default	Description
17:0	R/W	0	wrdc_weigh_sxn : unsigned , default = 0 the slv5 req weigh number [0*6+:6],the slv6 req weighnumber [1*6+:6],the slv7 req weighnumber [2*6+:6],

Table 9-2196 VDIN1\_RDWR\_ARB\_STATUS 0x13c4

Bit(s)	R/W	Default	Description
2	R.O	0	ro_wrarb_arb_busy : unsigned , default = 0
1	R/W	0x0	reserve :
0	R.O	0	ro_rdarb_arb_busy : unsigned , default = 0

Table 9-2197 VDIN1\_ARB\_DBG\_CTRL 0x13c5

Bit(s)	R/W	Default	Description
31:0	R.O	0	ro_det_cmd_ctrl : unsigned , default = 0

**Table 9-2198 VDIN1\_ARB\_DBG\_STAT 0x13C6**

Bit(s)	R/W	Default	Description
31:0	R.O	0	ro_det_dbg_stat : unsigned , default = 0

**Table 9-2199 VI\_HIST\_H\_START\_END 0x2e01**

Bit(s)	R/W	Default	Description
28-16	R/W	0	Hist_hstart, refer to VI_HIST_CTRL[1]
12-0	R/W	0	Hist_hend

**Table 9-2200 VI\_HIST\_V\_START\_END 0x2e02**

Bit(s)	R/W	Default	Description
28-16	R/W	0	Hist_vstart, refer to VI_HIST_CTRL[1]
12-0	R/W	0	Hist_vend

**Table 9-2201 VI\_HIST\_MAX\_MIN 0x2e03**

Bit(s)	R/W	Default	Description
15-8	R	0	hist_max maximum value
7-0	R	0	hist_min minimum value

**Table 9-2202 VI\_HIST\_SPL\_VAL 0x2e04**

Bit(s)	R/W	Default	Description
31-0	R	0	hist_spl_rd , counts for the total luma value

**Table 9-2203 VI\_HIST\_SPL\_PIX\_CNT 0x2e05**

Bit(s)	R/W	Default	Description
21-0	R	0	hist_spl_pixel_count, counts for the total calculated pixels

**Table 9-2204 VI\_HIST\_CHROMA\_SUM 0x2e06**

Bit(s)	R/W	Default	Description
31-0	R	0	hist_chroma_sum , counts for the total chroma value

//0-255 are splited to 64 bins evenly, and VDIN\_DNLP\_HISTXX

//are the statistic number of pixels that within each bin.

**Table 9-2205 VI\_DNLP\_HIST00 0x2e07**

Bit(s)	R/W	Default	Description
31-16	R	0	counts for the 2nd bin
15-0	R	0	counts for the 1st bin

**Table 9-2206 VI\_DNLP\_HIST01 0x2e08**

Bit(s)	R/W	Default	Description
31-16	R	0	counts for the 4th bin
15-0	R	0	counts for the 3rd bin

**Table 9-2207 VI\_DNLP\_HIST02 0x2e09**

Bit(s)	R/W	Default	Description
31-16	R	0	counts for the 6th bin
15-0	R	0	counts for the 5th bin

**Table 9-2208 VI\_DNLP\_HIST03 0x2e0a**

Bit(s)	R/W	Default	Description
31-16	R	0	counts for the 8th bin
15-0	R	0	counts for the 7th bin

**Table 9-2209 VI\_DNLP\_HIST04 0x2e0b**

Bit(s)	R/W	Default	Description
31-16	R	0	counts for the 10th bin
15-0	R	0	counts for the 9th bin

**Table 9-2210 VI\_DNLP\_HIST05 0x2e0c**

Bit(s)	R/W	Default	Description
31-16	R	0	counts for the 12th bin
15-0	R	0	counts for the 11th bin

**Table 9-2211 VI\_DNLP\_HIST06 0x2e0d**

Bit(s)	R/W	Default	Description
31-16	R	0	counts for the 14th bin
15-0	R	0	counts for the 13th bin

**Table 9-2212 VI\_DNLP\_HIST07 0x2e0e**

Bit(s)	R/W	Default	Description
31-16	R	0	counts for the 16th bin
15-0	R	0	counts for the 15th bin

**Table 9-2213 VI\_DNLP\_HIST08 0x2e0f**

Bit(s)	R/W	Default	Description
31-16	R	0	counts for the 18th bin
15-0	R	0	counts for the 17th bin

**Table 9-2214 VI\_DNLP\_HIST09 0x2e10**

Bit(s)	R/W	Default	Description
31-16	R	0	counts for the 20th bin
15-0	R	0	counts for the 19th bin

**Table 9-2215 VI\_DNLP\_HIST10 0x2e11**

Bit(s)	R/W	Default	Description
31-16	R	0	counts for the 22nd bin
15-0	R	0	counts for the 21st bin

**Table 9-2216 VI\_DNLP\_HIST11 0x2e12**

Bit(s)	R/W	Default	Description
31-16	R	0	counts for the 24th bin
15-0	R	0	counts for the 23rd bin

**Table 9-2217 VI\_DNLP\_HIST12 0x2e13**

Bit(s)	R/W	Default	Description
31-16	R	0	counts for the 26th bin
15-0	R	0	counts for the 25th bin

**Table 9-2218 VI\_DNLP\_HIST13 0x2e14**

Bit(s)	R/W	Default	Description
31-16	R	0	counts for the 28th bin
15-0	R	0	counts for the 27th bin

**Table 9-2219 VI\_DNLP\_HIST14 0x2e15**

Bit(s)	R/W	Default	Description
31-16	R	0	counts for the 30th bin
15-0	R	0	counts for the 29th bin

**Table 9-2220 VI\_DNLP\_HIST15 0x2e16**

Bit(s)	R/W	Default	Description
31-16	R	0	counts for the 32nd bin
15-0	R	0	counts for the 31st bin

**Table 9-2221 VI\_DNLP\_HIST16 0x2e17**

Bit(s)	R/W	Default	Description
31-16	R	0	counts for the 34th bin
15-0	R	0	counts for the 33rd bin

**Table 9-2222 VI\_DNLP\_HIST17 0x2e18**

Bit(s)	R/W	Default	Description
31-16	R	0	counts for the 36th bin
15-0	R	0	counts for the 35th bin

**Table 9-2223 VI\_DNLP\_HIST18 0x2e19**

Bit(s)	R/W	Default	Description
31-16	R	0	counts for the 38th bin
15-0	R	0	counts for the 37th bin

**Table 9-2224 VI\_DNLP\_HIST19 0x2e1a**

Bit(s)	R/W	Default	Description
31-16	R	0	counts for the 40th bin
15-0	R	0	counts for the 39th bin

**Table 9-2225 VI\_DNLP\_HIST20 0x2e1b**

Bit(s)	R/W	Default	Description
31-16	R	0	counts for the 42nd bin
15-0	R	0	counts for the 41st bin

**Table 9-2226 VI\_DNLP\_HIST21 0x2e1c**

Bit(s)	R/W	Default	Description
31-16	R	0	counts for the 44th bin
15-0	R	0	counts for the 43rd bin

**Table 9-2227 VI\_DNLP\_HIST22 0x2e1d**

Bit(s)	R/W	Default	Description
31-16	R	0	counts for the 46th bin
15-0	R	0	counts for the 45th bin

**Table 9-2228 VI\_DNLP\_HIST23 0x2e1e**

Bit(s)	R/W	Default	Description
31-16	R	0	counts for the 48th bin
15-0	R	0	counts for the 47th bin

**Table 9-2229 VI\_DNLP\_HIST24 0x2e1f**

Bit(s)	R/W	Default	Description
31-16	R	0	counts for the 50th bin
15-0	R	0	counts for the 49th bin

**Table 9-2230 VI\_DNLP\_HIST25 0x2e20**

Bit(s)	R/W	Default	Description
31-16	R	0	counts for the 52nd bin
15-0	R	0	counts for the 51st bin

**Table 9-2231 VI\_DNLP\_HIST26 0x2e21**

Bit(s)	R/W	Default	Description
31-16	R	0	counts for the 54th bin
15-0	R	0	counts for the 53rd bin

**Table 9-2232 VI\_DNLP\_HIST27 0x2e22**

Bit(s)	R/W	Default	Description
31-16	R	0	counts for the 56th bin
15-0	R	0	counts for the 55th bin

**Table 9-2233 VI\_DNLP\_HIST28 0x2e23**

Bit(s)	R/W	Default	Description
31-16	R	0	counts for the 58th bin
15-0	R	0	counts for the 57th bin

**Table 9-2234 VI\_DNLP\_HIST29 0x2e24**

Bit(s)	R/W	Default	Description
31-16	R	0	counts for the 60th bin
15-0	R	0	counts for the 59th bin

**Table 9-2235 VI\_DNLP\_HIST30 0x2e25**

Bit(s)	R/W	Default	Description
31-16	R	0	counts for the 62nd bin
15-0	R	0	counts for the 61st bin

**Table 9-2236 VI\_DNLP\_HIST31 0x2e26**

Bit(s)	R/W	Default	Description
31-16	R	0	counts for the 64th bin
15-0	R	0	counts for the 63rd bin

**Table 9-2237 VI\_DNLP\_HIST31 0x2e27**

Bit(s)	R/W	Default	Description
31-16	R	0	counts for the 66th bin, for white pix
15-0	R	0	counts for the 65th bin, for black pix

**Table 9-2238 VI\_HIST\_PIC\_SIZE 0x2e28**

Bit(s)	R/W	Default	Description
28-16	R/W	0	Hist_pic_height
12-0	R/W	0	Hist_pic_width

**Table 9-2239 VI\_HIST\_GCLK\_CTRL 0x2e2a**

Bit(s)	R/W	Default	Description
5-4	R/W	0	Gated clock control of hist_clk
3-2	R/W	0	Gated clock control of clk0
1-0	R/W	0	Gated clock control of hist register clock



### 9.2.3.43 Osd\_mali\_afbcd Registers

**Table 9-2240 VPU\_MAFBC\_BLOCK\_ID 0x3a00**

Bit(s)	R/W	Default	Description
31:16	R.O	0x0	PRODUCT_ID : // Contains a product-specific value
15:12	R.O	0x0	VERSION_MAJOR : // Major release number of the AFBC decoder. This is the R part of an RnPn release number.
11:4	R.O	0x0	VERSION_MINOR : // Minor release number of the AFBC decoder. This is the P part of an RnPn release number.
3:0	R.O	0x0	VERSION_STATUS : // The version status of the AFBC decoder release. Starts at 0 and increases by one for each release.

**Table 9-2241 VPU\_MAFBC\_IRQ\_RAW\_STATUS 0x3a01**

Bit(s)	R/W	Default	Description
5	R.O	0x0	SECURE_ID_ERROR : // Activated when an invalid TrustZone Media Protection (TZMP) transaction is detected on the TZMP1 or TZMP2 data fields.
4	R.O	0x0	AXI_ERROR : // Activated when an AXI error is detected.
3	R.O	0x0	DETILING_ERROR : // Activated when a detiling error occurs.
2	R.O	0x0	DECODE_ERROR : // Activated when decoder core indicates a decoder error.
1	R.O	0x0	CONFIGURATION_SWAPPED : // Activated when configuration has been swapped from shadow registers to configuration registers.
0	R.O	0x0	SURFACES_COMPLETED : // Activated when all enabled surfaces have completed and have been fully read out. In continuous mode, this interrupt is triggered each time all surfaces have been read out.

**Table 9-2242 VPU\_MAFBC\_IRQ\_CLEAR 0x3a02**

Bit(s)	R/W	Default	Description
5	R/W	0	SECURE_ID_ERROR : // unsigned , default = 0, Writing a 1 to this bit clears the corresponding bit in the IRQ_RAW_STATUS register.
4	R/W	0	AXI_ERROR : // unsigned , default = 0, Writing a 1 to this bit clears the corresponding bit in the IRQ_RAW_STATUS register.
3	R/W	0	DETILING_ERROR : // unsigned , default = 0, Writing a 1 to this bit clears the corresponding bit in the IRQ_RAW_STATUS register.
2	R/W	0	DECODE_ERROR : // unsigned , default = 0, Writing a 1 to this bit clears the corresponding bit in the IRQ_RAW_STATUS register.
1	R/W	0	CONFIGURATION_SWAPPED : // unsigned , default = 0, Writing a 1 to this bit clears the corresponding bit in the IRQ_RAW_STATUS register.
0	R/W	0	SURFACES_COMPLETED : // unsigned , default = 0, Writing a 1 to this bit clears the corresponding bit in the IRQ_RAW_STATUS register.

Table 9-2243 VPU\_MAFBC\_IRQ\_MASK 0x3a03

Bit(s)	R/W	Default	Description
5	R/W	0	SECURE_ID_ERROR : // unsigned , default = 0,When this is set to 1, the corresponding IRQ_RAW_STATUS interrupt is enabled. When this is set to zero, the corresponding IRQ_RAW_STATUS interrupt is disabled.
4	R/W	0	AXI_ERROR : // unsigned , default = 0,When this is set to 1, the corresponding IRQ_RAW_STATUS interrupt is enabled. When this is set to zero, the corresponding IRQ_RAW_STATUS interrupt is disabled.
3	R/W	0	DETILING_ERROR : // unsigned , default = 0,When this is set to 1, the corresponding IRQ_RAW_STATUS interrupt is enabled. When this is set to zero, the corresponding IRQ_RAW_STATUS interrupt is disabled.
2	R/W	0	DECODE_ERROR : // unsigned , default = 0, When this is set to 1, the corresponding IRQ_RAW_STATUS interrupt is enabled. When this is set to zero, the corresponding IRQ_RAW_STATUS interrupt is disabled.
1	R/W	0	CONFIGURATION_SWAPPED : // unsigned , default = 0, When this is set to 1, the corresponding IRQ_RAW_STATUS interrupt is enabled. When this is set to zero, the corresponding IRQ_RAW_STATUS interrupt is disabled.
0	R/W	0	SURFACES_COMPLETED : // unsigned , default = 0, When this is set to 1, the corresponding IRQ_RAW_STATUS interrupt is enabled. When this is set to zero, the corresponding IRQ_RAW_STATUS interrupt is disabled.

Table 9-2244 VPU\_MAFBC\_IRQ\_STATUS 0x3a04

Bit(s)	R/W	Default	Description
5	R.O	0x0	SECURE_ID_ERROR : //When this is set to 1, it asserts the corresponding external interrupt. This signals an interruptrequest to the application processor.
4	R.O	0x0	AXI_ERROR : //When this is set to 1, it asserts the corresponding external interrupt. This signals an interruptrequest to the application processor.
3	R.O	0x0	DETILING_ERROR : //When this is set to 1, it asserts the corresponding external interrupt. This signals an interruptrequest to the application processor.
2	R.O	0x0	DECODE_ERROR : //When this is set to 1, it asserts the corresponding external interrupt. This signals an interruptrequest to the application processor.
1	R.O	0x0	CONFIGURATION_SWAPPED : //When this is set to 1, it asserts the corresponding external interrupt. This signals an interruptrequest to the application processor.
0	R.O	0x0	SURFACES_COMPLETED : //When this is set to 1, it asserts the corresponding external interrupt. This signals an interruptrequest to the application processor.

Table 9-2245 VPU\_MAFBC\_COMMAND 0x3a05

Bit(s)	R/W	Default	Description
1	R/W	0x0	PENDING_SWAP : //Performs a swap of shadow registers when the current decode operations are completed. After a swap,decoding of the new surfaces starts.
0	R/W	0x0	DIRECT_SWAP : //Performs a swap of shadow registers immediately.Current decode operations are terminated before completion . After termination, decoding of the new surfaces is started

**Table 9-2246 VPU\_MAFBC\_STATUS 0x3a06**

Bit(s)	R/W	Default	Description
2	R.O	0x0	ERROR : //When this is 1, it indicates that the AFBC decoder is in an unrecoverable state and must be reset using RESETn to continue operation. This is flagged after a DETILING_ERROR.
1	R.O	0x0	SWAPPING : //When this is 1, the AFBC decoder is swapping surface configurations.
0	R.O	0x0	ACTIVE : //When this is 1, the AFBC decoder is decoding surfaces.

**Table 9-2247 VPU\_MAFBC\_SURFACE\_CFG 0x3a07**

Bit(s)	R/W	Default	Description
16	R/W	0	CONTINUOUS_DECODING_ENABLE : //unsigned , default = 0, Enables continuous decoding of surfaces when it is set to 1. This bit describes what the decoder does when one set of surfaces has been completed. If this is 1, the decoder immediately begins decoding again. In this case, the configuration for the next surface depends on whether the software has performed a swap operation. If no swap is used, the same configuration is used. If this is 0, the decoder waits for a software input.
3	R/W	0	S3_ENABLE : //unsigned , default = 0, When this is 1, surface 3 enabled.
2	R/W	0	S2_ENABLE : //unsigned , default = 0, When this is 1, surface 2 enabled.
1	R/W	0	S1_ENABLE : //unsigned , default = 0, When this is 1, surface 1 enabled.
0	R/W	0	S0_ENABLE : //unsigned , default = 0, When this is 1, surface 0 enabled.

**Table 9-2248 VPU\_MAFBC\_AXI\_CFG 0x3a08**

Bit(s)	R/W	Default	Description
7:4	R/W	0	CACHE : //unsigned , default = 0, This value is driven on the ARCACHEM signal.
3:0	R/W	0	QOS : //unsigned , default = 0, This value is driven on the ARQOSM signal.

**Table 9-2249 VPU\_MAFBC\_HEADER\_BUF\_ADDR\_LOW\_S0 0x3a10**

Bit(s)	R/W	Default	Description
31:0	R/W	0	HEADER_BUF_ADDR : [31:0] //unsigned , default = 0, Contains bits [31:0] of the header buffer address, Bits [5:0] must be set to 0 for alignment requirements.

**Table 9-2250 VPU\_MAFBC\_HEADER\_BUF\_ADDR\_HIGH\_S0 0x3a11**

Bit(s)	R/W	Default	Description
15:0	R/W	0	HEADER_BUF_ADDR : [47:32] //unsigned , default = 0, Contains the upper 16 bits of the header buffer address

**Table 9-2251 VPU\_MAFBC\_FORMAT\_SPECIFIER\_S0 0x3a12**

Bit(s)	R/W	Default	Description
19	R/W	0	PAYLOAD_LIMIT_EN : // unsigned , default = 0,Enable payload read address check against the min and max payload address boundaries: 0 Disable 1 Enable. This means that out-of-bound reads output the color black.
18	R/W	0	TILED_HEADER_EN : // unsigned , default = 0,Enables tiled header mode:0 Disable tiled header 1 Enable tiled header
17:16	R/W	0	SUPER_BLOCK_ASPECT : // unsigned , default = 0,Selects superblock aspect ratio 00:16x16 pixels 01:32x8 pixels other:reserved
9	R/W	0	BLOCK_SPLIT : //unsigned , default = 0,Enables block split mode: 0 Block split mode off. 1 Block split mode on.
8	R/W	0	YUV_TRANSFORM : //unsigned , default = 0,Enables the internal YUV transform stage: 0 Internal YUV transform off. 1 Internal YUV transform on.
3:0	R/W	0	PIXEL_FORMAT : //unsigned , default = 0,Contains the pixel format configuration.

**Table 9-2252 VPU\_MAFBC\_BUFFER\_WIDTH\_S0 0x3a13**

Bit(s)	R/W	Default	Description
13:0	R/W	0	BUFFER_WIDTH : //unsigned , default = 0,AFBC buffer width in pixels

**Table 9-2253 VPU\_MAFBC\_BUFFER\_HEIGHT\_S0 0x3a14**

Bit(s)	R/W	Default	Description
13:0	R/W	0	BUFFER_HEIGHT : //unsigned , default = 0,AFBC buffer height in pixels

**Table 9-2254 VPU\_MAFBC\_BOUNDING\_BOX\_X\_START\_S0 0x3a15**

Bit(s)	R/W	Default	Description
12:0	R/W	0	BUFFER_X_START : //unsigned , default = 0,The AFBC buffer bounding box minimum x value. Given in pixels.

**Table 9-2255 VPU\_MAFBC\_BOUNDING\_BOX\_X\_END\_S0 0x3a16**

Bit(s)	R/W	Default	Description
12:0	R/W	0	BUFFER_X_END : //unsigned , default = 0,The AFBC buffer bounding box maximum x value. Given in pixels.

**Table 9-2256 VPU\_MAFBC\_BOUNDING\_BOX\_Y\_START\_S0 0x3a17**

Bit(s)	R/W	Default	Description
12:0	R/W	0	BUFFER_Y_START : //unsigned , default = 0,The AFBC buffer bounding box minimum y value. Given in pixels.

Table 9-2257 VPU\_MAFBC\_BOUNDING\_BOX\_Y\_END\_S0 0x3a18

Bit(s)	R/W	Default	Description
12:0	R/W	0	BUFFER_Y_START : //unsigned , default = 0,The AFBC buffer bounding box maximum y value. Given in pixels.

Table 9-2258 VPU\_MAFBC\_OUTPUT\_BUF\_ADDR\_LOW\_S0 0x3a19

Bit(s)	R/W	Default	Description
31:0	R/W	0	OUTPUT_BUF_ADDR : [31:0] //unsigned , default = 0,Contains bits [31:0] of the output buffer address.Bits [6:0] must be set to 0 for alignment requirements. The address, frame size, and pixel format allocate area in the detiler SRAM for the current surface . You must ensure that the allocated area does not exceed the available SRAM, or overlap with other surfaces or planes that are defined in the output buffer.

Table 9-2259 VPU\_MAFBC\_OUTPUT\_BUF\_ADDR\_HIGH\_S0 0x3a1a

Bit(s)	R/W	Default	Description
15:0	R/W	0x0	OUTPUT_BUF_ADDR : [47:32] //Contains the upper 16 bits of the output buffer address

Table 9-2260 VPU\_MAFBC\_OUTPUT\_BUF\_STRIDE\_S0 0x3a1b

Bit(s)	R/W	Default	Description
15:0	R/W	0	OUTPUT_BUF_STRIDE : [15:0] //unsigned , default = 0,Contains bits [15:0] of the output buffer stride.Bits [6:0] must be set to 0 for alignment requirements. The maximum permitted buffer stride is 8192 pixels wide. The byte size depends on the pixel format for the surface.

Table 9-2261 VPU\_MAFBC\_PREFETCH\_CFG\_S0 0x3a1c

Bit(s)	R/W	Default	Description
1	R/W	0	PREFETCH_READ_DIRECTION_Y : // unsigned , default = 0,Defines the pre-fetch read direction in Y: 0 Top to bottom 1 Bottom to top
0	R/W	0	PREFETCH_READ_DIRECTION_X : //unsigned , default = 0,Defines the pre-fetch read direction in X 0 Left to right 1 Right to left

Table 9-2262 VPU\_MAFBC\_PAYLOAD\_MIN\_LOW\_S0 0x3a1d

Bit(s)	R/W	Default	Description
31:0	R/W	0	PAYLOAD_MIN_LOW : //unsigned , default = 0, Indicates the lower 32 bits of the AFBC payload buffer minimum address.

Table 9-2263 VPU\_MAFBC\_PAYLOAD\_MIN\_HIGH\_S0 0x3a1e

Bit(s)	R/W	Default	Description
15:0	R/W	0	PAYLOAD_MIN_HIGH : //unsigned , default = 0, Indicates the higher 16 bits of the AFBC payload buffer minimum address.

**Table 9-2264 VPU\_MAFBC\_PAYLOAD\_MAX\_LOW\_S0 0x3a1f**

Bit(s)	R/W	Default	Description
31:0	R/W	0x0	PAYLOAD_MIN_LOW : //unsigned , ndicates the lower 32 bits of the AFBC payload buffer maximum address.

**Table 9-2265 VPU\_MAFBC\_PAYLOAD\_MAX\_HIGH\_S0 0x3a20**

Bit(s)	R/W	Default	Description
15:0	R/W	0	PAYLOAD_MIN_HIGH : //unsigned , default = 0, Indicates the higher 16 bits of the AFBC payload buffer maximum address.

VPU\_MAFBC\_HEADER\_BUF\_ADDR\_LOW\_S1 0x3a30

See VPU\_MAFBC\_HEADER\_BUF\_ADDR\_LOW\_S0

VPU\_MAFBC\_HEADER\_BUF\_ADDR\_HIGH\_S1 0x3a31

See VPU\_MAFBC\_HEADER\_BUF\_ADDR\_HIGH\_S0

VPU\_MAFBC\_FORMAT\_SPECIFIER\_S1 0x3a32

See VPU\_MAFBC\_FORMAT\_SPECIFIER\_S0

VPU\_MAFBC\_BUFFER\_WIDTH\_S1 0x3a33

See VPU\_MAFBC\_BUFFER\_WIDTH\_S0

VPU\_MAFBC\_BUFFER\_HEIGHT\_S1 0x3a34

See VPU\_MAFBC\_BUFFER\_HEIGHT\_S0

VPU\_MAFBC\_BOUNDING\_BOX\_X\_START\_S1 0x3a35

See VPU\_MAFBC\_BOUNDING\_BOX\_X\_START\_S0

VPU\_MAFBC\_BOUNDING\_BOX\_X\_END\_S1 0x3a36

See VPU\_MAFBC\_BOUNDING\_BOX\_X\_END\_S0

VPU\_MAFBC\_BOUNDING\_BOX\_Y\_START\_S1 0x3a37

See VPU\_MAFBC\_BOUNDING\_BOX\_Y\_START\_S0

VPU\_MAFBC\_BOUNDING\_BOX\_Y\_END\_S1 0x3a38

See VPU\_MAFBC\_BOUNDING\_BOX\_Y\_END\_S0

VPU\_MAFBC\_OUTPUT\_BUF\_ADDR\_LOW\_S1 0x3a39

See VPU\_MAFBC\_OUTPUT\_BUF\_ADDR\_LOW\_S0

VPU\_MAFBC\_OUTPUT\_BUF\_ADDR\_HIGH\_S1 0x3a3a

See VPU\_MAFBC\_OUTPUT\_BUF\_ADDR\_HIGH\_S0

VPU\_MAFBC\_OUTPUT\_BUF\_STRIDE\_S1 0x3a3b

See VPU\_MAFBC\_OUTPUT\_BUF\_STRIDE\_S0

VPU\_MAFBC\_PREFETCH\_CFG\_S1 0x3a3c

See VPU\_MAFBC\_PREFETCH\_CFG\_S0

VPU\_MAFBC\_PAYLOAD\_MIN\_LOW\_S1 0x3a3d

See VPU\_MAFBC\_PAYLOAD\_MIN\_LOW\_S0

VPU\_MAFBC\_PAYLOAD\_MIN\_HIGH\_S1 0x3a3e

See VPU\_MAFBC\_PAYLOAD\_MIN\_HIGH\_S0

VPU\_MAFBC\_PAYLOAD\_MAX\_LOW\_S1 0x3a3f

See VPU\_MAFBC\_PAYLOAD\_MAX\_LOW\_S0

VPU\_MAFBC\_PAYLOAD\_MAX\_HIGH\_S1 0x3a40

See VPU\_MAFBC\_PAYLOAD\_MAX\_HIGH\_S0

VPU\_MAFBC\_HEADER\_BUF\_ADDR\_LOW\_S2 0x3a50

See VPU\_MAFBC\_HEADER\_BUF\_ADDR\_LOW\_S0

VPU\_MAFBC\_HEADER\_BUF\_ADDR\_HIGH\_S2 0x3a51

See VPU\_MAFBC\_HEADER\_BUF\_ADDR\_HIGH\_S0

VPU\_MAFBC\_FORMAT\_SPECIFIER\_S2 0x3a52

See VPU\_MAFBC\_FORMAT\_SPECIFIER\_S0

VPU\_MAFBC\_BUFFER\_WIDTH\_S2 0x3a53

See VPU\_MAFBC\_BUFFER\_WIDTH\_S0

VPU\_MAFBC\_BUFFER\_HEIGHT\_S2 0x3a54

See VPU\_MAFBC\_BUFFER\_HEIGHT\_S0

VPU\_MAFBC\_BOUNDING\_BOX\_X\_START\_S2 0x3a55

See VPU\_MAFBC\_BOUNDING\_BOX\_X\_START\_S0

VPU\_MAFBC\_BOUNDING\_BOX\_X\_END\_S2 0x3a56

See VPU\_MAFBC\_BOUNDING\_BOX\_X\_END\_S0

VPU\_MAFBC\_BOUNDING\_BOX\_Y\_START\_S2 0x3a57

See VPU\_MAFBC\_BOUNDING\_BOX\_Y\_START\_S0

VPU\_MAFBC\_BOUNDING\_BOX\_Y\_END\_S2 0x3a58

See VPU\_MAFBC\_BOUNDING\_BOX\_Y\_END\_S0

VPU\_MAFBC\_OUTPUT\_BUF\_ADDR\_LOW\_S2 0x3a59

See VPU\_MAFBC\_OUTPUT\_BUF\_ADDR\_LOW\_S0

VPU\_MAFBC\_OUTPUT\_BUF\_ADDR\_HIGH\_S2 0x3a5a

See VPU\_MAFBC\_OUTPUT\_BUF\_ADDR\_HIGH\_S0

VPU\_MAFBC\_OUTPUT\_BUF\_STRIDE\_S2 0x3a5b

See VPU\_MAFBC\_OUTPUT\_BUF\_STRIDE\_S0

VPU\_MAFBC\_PREFETCH\_CFG\_S2 0x3a5c

See VPU\_MAFBC\_PREFETCH\_CFG\_S0

VPU\_MAFBC\_PAYLOAD\_MIN\_LOW\_S2 0x3a5d

See VPU\_MAFBC\_PAYLOAD\_MIN\_LOW\_S0

VPU\_MAFBC\_PAYLOAD\_MIN\_HIGH\_S2 0x3a5e

See VPU\_MAFBC\_PAYLOAD\_MIN\_HIGH\_S0

VPU\_MAFBC\_PAYLOAD\_MAX\_LOW\_S2 0x3a5f

See VPU\_MAFBC\_PAYLOAD\_MAX\_LOW\_S0

VPU\_MAFBC\_PAYLOAD\_MAX\_HIGH\_S2 0x3a60

See VPU\_MAFBC\_PAYLOAD\_MAX\_HIGH\_S0

VPU\_MAFBC\_HEADER\_BUF\_ADDR\_LOW\_S3 0x3a70

See VPU\_MAFBC\_HEADER\_BUF\_ADDR\_LOW\_S0



VPU\_MAFBC\_HEADER\_BUF\_ADDR\_HIGH\_S3 0x3a71

See VPU\_MAFBC\_HEADER\_BUF\_ADDR\_HIGH\_S0

VPU\_MAFBC\_FORMAT\_SPECIFIER\_S3 0x3a72

See VPU\_MAFBC\_FORMAT\_SPECIFIER\_S0

VPU\_MAFBC\_BUFFER\_WIDTH\_S3 0x3a73

See VPU\_MAFBC\_BUFFER\_WIDTH\_S0

VPU\_MAFBC\_BUFFER\_HEIGHT\_S3 0x3a74

See VPU\_MAFBC\_BUFFER\_HEIGHT\_S0

VPU\_MAFBC\_BOUNDING\_BOX\_X\_START\_S3 0x3a75

See VPU\_MAFBC\_BOUNDING\_BOX\_X\_START\_S0

VPU\_MAFBC\_BOUNDING\_BOX\_X\_END\_S3 0x3a76

See VPU\_MAFBC\_BOUNDING\_BOX\_X\_END\_S0

VPU\_MAFBC\_BOUNDING\_BOX\_Y\_START\_S3 0x3a77

See VPU\_MAFBC\_BOUNDING\_BOX\_Y\_START\_S0

VPU\_MAFBC\_BOUNDING\_BOX\_Y\_END\_S3 0x3a78

See VPU\_MAFBC\_BOUNDING\_BOX\_Y\_END\_S0

VPU\_MAFBC\_OUTPUT\_BUF\_ADDR\_LOW\_S3 0x3a79

See VPU\_MAFBC\_OUTPUT\_BUF\_ADDR\_LOW\_S0

VPU\_MAFBC\_OUTPUT\_BUF\_ADDR\_HIGH\_S3 0x3a7a

See VPU\_MAFBC\_OUTPUT\_BUF\_ADDR\_HIGH\_S0

VPU\_MAFBC\_OUTPUT\_BUF\_STRIDE\_S3 0x3a7b

See VPU\_MAFBC\_OUTPUT\_BUF\_STRIDE\_S0

VPU\_MAFBC\_PREFETCH\_CFG\_S3 0x3a7c

See VPU\_MAFBC\_PREFETCH\_CFG\_S0

VPU\_MAFBC\_PAYLOAD\_MIN\_LOW\_S3 0x3a7d

See VPU\_MAFBC\_PAYLOAD\_MIN\_LOW\_S0

VPU\_MAFBC\_PAYLOAD\_MIN\_HIGH\_S3 0x3a7e

See VPU\_MAFBC\_PAYLOAD\_MIN\_HIGH\_S0

VPU\_MAFBC\_PAYLOAD\_MAX\_LOW\_S3 0x3a7f

See VPU\_MAFBC\_PAYLOAD\_MAX\_LOW\_S0

VPU\_MAFBC\_PAYLOAD\_MAX\_HIGH\_S3 0x3a80

See VPU\_MAFBC\_PAYLOAD\_MAX\_HIGH\_S0

### 9.2.3.44 Primesl Registers

**Table 9-2266 PRIMESL\_LUTC\_ADDR\_PORT 0x3980**

Bit(s)	R/W	Default	Description
8: 0	R/W	0	lutc_addr : // unsigned , default = 0 = 'h0,

**Table 9-2267 PRIMESL\_LUTC\_DATA\_PORT 0x3981**

Bit(s)	R/W	Default	Description
10: 0	R/W	0	lutc_data : // unsigned , default = 0 = 'h0,

**Table 9-2268 PRIMESL\_LUTP\_ADDR\_PORT 0x3982**

Bit(s)	R/W	Default	Description
8: 0	R/W	0	lutp_addr : // unsigned , default = 0 = 'h0,

**Table 9-2269 PRIMESL\_LUTP\_DATA\_PORT 0x3983**

Bit(s)	R/W	Default	Description
13: 0	R/W	0	lutp_data : // unsigned , default = 0 = 'h0,

**Table 9-2270 PRIMESL\_LUTD\_ADDR\_PORT 0x3984**

Bit(s)	R/W	Default	Description
8: 0	R/W	0	lutd_data : // unsigned , default = 0 = 'h0,

**Table 9-2271 PRIMESL\_LUTD\_DATA\_PORT 0x3985**

Bit(s)	R/W	Default	Description
11: 0	R/W	0	lutd_data : // unsigned , default = 0 = 'h0,

**Table 9-2272 PRIMESL\_CTRL0 0x3990**

Bit(s)	R/W	Default	Description
29	R/W	0	legacy_mode_en : // unsigned , default = 0 = 'h0
28	R/W	1	clip_en : // unsigned , default = 1 = 'h0
26:16	R/W	0	inv_chroma_ratio : // unsigned , default = 0 = 'h0,
14: 4	R/W	0	inv_y_ratio : // unsigned , default = 0 = 'h0,
3	R/W	0	reg_gclk_ctrl : // unsigned , default = 0 = 'h0,
2: 1	R/W	0	gclk_ctrl : // unsigned , default = 0 = 'h0,
0	R/W	1	primesl_en : // unsigned , default = 1 = 'h0,

**Table 9-2273 PRIMESL\_CTRL1 0x3991**

Bit(s)	R/W	Default	Description
25:16	R/W	0	l_headroom : // unsigned , default = 0 = 'h0,
9: 0	R/W	0	footroom : // unsigned , default = 0 = 'h0,

**Table 9-2274 PRIMESL\_CTRL2 0x3992**

Bit(s)	R/W	Default	Description
9: 0	R/W	0	c_headroom : // unsigned , default = 0 = 'h0,

**Table 9-2275 PRIMESL\_CTRL3 0x3993**

Bit(s)	R/W	Default	Description
29:16	R/W	0	mub : // unsigned , default = 0 = 'h0,
13: 0	R/W	0	mua : // unsigned , default = 0 = 'h0,

**Table 9-2276 PRIMESL\_CTRL4 0x3994**

Bit(s)	R/W	Default	Description
25:16	R/W	0	oct_7_1 : // signed , default = 0 = 'h0,
9: 0	R/W	0	oct_7_0 : // signed , default = 0 = 'h0,

**Table 9-2277 PRIMESL\_CTRL5 0x3995**

Bit(s)	R/W	Default	Description
25:16	R/W	0	oct_7_3 : // signed , default = 0 = 'h0,
9: 0	R/W	0	oct_7_2 : // signed , default = 0 = 'h0,

**Table 9-2278 PRIMESL\_CTRL6 0x3996**

Bit(s)	R/W	Default	Description
25:16	R/W		oct_7_5 : // signed , default = 0 = 'h0,
9: 0	R/W		oct_7_4 : // signed , default = 0 = 'h0,

**Table 9-2279 PRIMESL\_CTRL7 0x3997**

Bit(s)	R/W	Default	Description
9: 0	R/W	0	oct_7_6 : // signed , default = 0 = 'h0,

**Table 9-2280 PRIMESL\_CTRL8 0x3998**

Bit(s)	R/W	Default	Description
28:16	R/W	0	d_lut_threshold_3_1 : // unsigned , default = 0 = 'h0,
12: 0	R/W	0	d_lut_threshold_3_0 : // unsigned , default = 0 = 'h0,

**Table 9-2281 PRIMESL\_CTRL9 0x3999**

Bit(s)	R/W	Default	Description
12: 0	R/W	0	d_lut_threshold_3_2 : // unsigned , default = 0 = 'h0,

**Table 9-2282 PRIMESL\_CTRL10 0x399a**

Bit(s)	R/W	Default	Description
15:12	R/W	0	d_lut_step_4_3 : // unsigned , default = 0 = 'h0,
11: 8	R/W	0	d_lut_step_4_2 : // unsigned , default = 0 = 'h0,
7: 4	R/W	0	d_lut_step_4_1 : // unsigned , default = 0 = 'h0,
3: 0	R/W	0	d_lut_step_4_0 : // unsigned , default = 0 = 'h0,

**Table 9-2283 PRIMESL\_CTRL11 0x399b**

Bit(s)	R/W	Default	Description
28:16	R/W	0	rgb2yuv_9_0 : // signed , default = 0 = 'h0,
12: 0	R/W	0	rgb2yuv_9_1 : // signed , default = 0 = 'h0,

**Table 9-2284 PRIMESL\_CTRL12 0x399c**

Bit(s)	R/W	Default	Description
28:16	R/W	0	rgb2yuv_9_2 : // signed , default = 0 = 'h0,
12: 0	R/W	0	rgb2yuv_9_3 : // signed , default = 0 = 'h0,

**Table 9-2285 PRIMESL\_CTRL13 0x399d**

Bit(s)	R/W	Default	Description
28:16	R/W	0	rgb2yuv_9_4 : // signed , default = 0 = 'h0,
12: 0	R/W	0	rgb2yuv_9_5 : // signed , default = 0 = 'h0,

**Table 9-2286 PRIMESL\_CTRL14 0x399e**

Bit(s)	R/W	Default	Description
28:16	R/W	0	rgb2yuv_9_6 : // signed , default = 0 = 'h0,
12: 0	R/W	0	rgb2yuv_9_7 : // signed , default = 0 = 'h0,

**Table 9-2287 PRIMESL\_CTRL15 0x399f**

Bit(s)	R/W	Default	Description
12: 0	R/W	0	rgb2yuv_9_8 : // signed , default = 0 = 'h0,

### 9.2.3.45 VADJ1/RGB\_CONBRI Registers

**Table 9-2288 VPP\_VADJ1\_MISC 0x3280**

Bit(s)	R/W	Default	Description
5:4	R/W	0	Gate clk ctrl for vadj1
3	/	/	/
2	R/W	0	Sync enable 1:vadj1 regs work when go_field come 1:vadj1 regs directly
1	R/W	0	minus black level enable for vadj1
0	R/W	0	Module enable

**Table 9-2289 VPP\_VADJ1\_BLACK\_VAL 0X3281**

Bit(s)	R/W	Default	Description
28:16	R/W	13'h200	Black_luma
12:0	R/W	13'h40	Black_chroma

**Table 9-2290 VPP\_VADJ1\_Y 0x3282**

Bit(s)	R/W	Default	Description
17-8	R/W	0	brightness, signed value
7-0	R/W	0x1d0	contrast, unsigned value, contrast from 0 <= contrast <2

$$cb' = cb*ma + cr*mb$$

$$cr' = cb*mc + cr*md$$

**Table 9-2291 VPP\_VADJ1\_MA\_MB 0x3283**

Bit(s)	R/W	Default	Description
25-16	R/W	0x100	MA, signed value, $-2 < MA < 2$
9-0	R/W	0	MB, signed value, $-2 < MB < 2$

**Table 9-2292 VPP\_VADJ1\_MC\_MD 0x3284**

Bit(s)	R/W	Default	Description
25-16	R/W	0	MC, signed value, $-2 < MC < 2$
9-0	R/W	0x100	MD, signed value, $-2 < MD < 2$

**Table 9-2293 VPP\_VADJ1\_CURV\_0 0x3285**

Bit(s)	R/W	Default	Description
31:24	R/W	0	vadj1_softcon_curv0_ci, u8
23:12	R/W	0	vadj1_softcon_curv0_b, u12
11:0	R/W	0	vadj1_softcon_curv0_a, s12

**Table 9-2294 VPP\_VADJ1\_CURV\_1 0x3286**

Bit(s)	R/W	Default	Description
31:13			Reserved
12:4	R/W	0	vadj1_softcon_curv0_g, s9
3			Reserved
2:0	R/W	0	vadj1_softcon_curv0_cs, u3

**Table 9-2295 VPP\_VADJ1\_CURV\_2 0x3287**

Bit(s)	R/W	Default	Description
31:24	R/W	0	vadj1_softcon_curv1_ci, u8
23:12	R/W	0	vadj1_softcon_curv1_b, u12
11:0	R/W	0	vadj1_softcon_curv1_a, s12

**Table 9-2296 VPP\_VADJ1\_CURV\_3 0x3288**

Bit(s)	R/W	Default	Description
31:13			Reserved
12:4	R/W	0	vadj1_softcon_curv1_g, s9
3			Reserved
2:0	R/W	0	vadj1_softcon_curv1_cs, u3

**Table 9-2297 VPP\_VD1\_RGB\_CTRST 0x3289**

Bit(s)	R/W	Default	Description
31:28			Reserved
27:16	R/W	1024	Vd1_rgb_ctrst: contrast for rgb, normalized 1024 as '1.0'
15			Reserved
14:2	R/W	64	Vd1_rgb_ctrst_blklvl: contrast black level to be subtract before and add back after the contrast gain operation
1	R/W	0	Vd1_rgbbst_en: 1 to enable the RGB_BST
0	R/W	1	Vd1_rgb_ctrst_prt: enable signal to protect saturation in rgb (no clipping) during contrast adjustment

**Table 9-2298 VPP\_VD1\_RGB\_BRGHT 0x328A**

Bit(s)	R/W	Default	Description
31:14			Reserved
13:2	R/W	0	Vd1_rgb_brgh: brightness level in rgb domain
1	R/W	1	Vd1_rgb_brgh_prt: enable signal to protect saturation in rgb (no clipping) during brightness adjustment
0	R/W	0	Vd1_rgb_ctrst_dlut_x2: Enable signal to do x2 to the dlut cells before subtracting from the normalized gain_max; 0:x1 1:x2

**Table 9-2299 VPP\_VD1\_RGB\_DLUT\_0\_3 0x328B**

Bit(s)	R/W	Default	Description
31:24	R/W	255	Vd1_rgbbst_dlut0: Differential gain to normalized gain_max to customized protection curve. e.g. [255 205 171 147 128 113 102 93 85 78 73 68] for protection of not boost for pixels larger than 240
23:16	R/W	205	Vd1_rgbbst_dlut1: same as Vd1_rgbbst_dlut0
15:8	R/W	171	Vd1_rgbbst_dlut2: same as Vd1_rgbbst_dlut0
7:0	R/W	147	Vd1_rgbbst_dlut3: same as Vd1_rgbbst_dlut0

**Table 9-2300 VPP\_VD1\_RGB\_DLUT\_4\_7 0x328c**

Bit(s)	R/W	Default	Description
31:24	R/W	128	Vd1_rgbbst_dlut4: same as Vd1_rgbbst_dlut0
23:16	R/W	113	Vd1_rgbbst_dlut5: same as Vd1_rgbbst_dlut0
15:8	R/W	102	Vd1_rgbbst_dlut6: same as Vd1_rgbbst_dlut0
7:0	R/W	93	Vd1_rgbbst_dlut7: same as Vd1_rgbbst_dlut0

**Table 9-2301 VPP\_VD1\_RGB\_DLUT\_8\_11 0x328d**

Bit(s)	R/W	Default	Description
31:24	R/W	85	Vd1_rgbbst_dlut8: same as Vd1_rgbbst_dlut0
23:16	R/W	78	Vd1_rgbbst_dlut9: same as Vd1_rgbbst_dlut0
15:8	R/W	73	Vd1_rgbbst_dlut10: same as Vd1_rgbbst_dlut0
7:0	R/W	68	Vd1_rgbbst_dlut11: same as Vd1_rgbbst_dlut0

**Table 9-2302 VPP\_VADJ2\_MISC 0x32a0**

Bit(s)	R/W	Default	Description
5:4	R/W	0	Gate clk ctrl for vadj2
3	/	/	/
2	R/W	0	Sync enable 1:vadj2 regs work when go_field come 1:vadj2 regs directly
1	R/W	0	minus black level enable for vadj2
0	R/W	0	Module enable

**Table 9-2303 VPP\_VADJ2\_BLACK\_VAL 0X32a1**

Bit(s)	R/W	Default	Description
28:16	R/W	13'h200	Black_luma
12:0	R/W	13'h40	Black_chroma

**Table 9-2304 VPP\_VADJ2\_Y 0x32a2**

Bit(s)	R/W	Default	Description
17-8	R/W	0	brightness, signed value
7-0	R/W	0x1d0	contrast, unsigned value, contrast from 0 <= contrast <2

$$cb' = cb*ma + cr*mb$$

$$cr' = cb*mc + cr*md$$

**Table 9-2305 VPP\_VADJ2\_MA\_MB 0x32a3**

Bit(s)	R/W	Default	Description
25-16	R/W	0x100	MA, signed value, -2 < MA < 2
9-0	R/W	0	MB, signed value, -2 < MB < 2

**Table 9-2306 VPP\_VADJ2\_MC\_MD 0x32a4**

Bit(s)	R/W	Default	Description
25-16	R/W	0	MC, signed value, -2 < MC < 2
9-0	R/W	0x100	MD, signed value, -2 < MD < 2



**Table 9-2307 VPP\_VADJ2\_CURV\_0 0x32a5**

Bit(s)	R/W	Default	Description
31:24	R/W	0	Vadj2_softcon_curv0_ci, u8
23:12	R/W	0	Vadj2_softcon_curv0_b, u12
11:0	R/W	0	Vadj2_softcon_curv0_a, s12

**Table 9-2308 VPP\_VADJ2\_CURV\_1 0x32a6**

Bit(s)	R/W	Default	Description
31:13			Reserved
12:4	R/W	0	Vadj2_softcon_curv0_g, s9
3			Reserved
2:0	R/W	0	Vadj2_softcon_curv0_cs, u3

**Table 9-2309 VPP\_VADJ2\_CURV\_2 0x32a7**

Bit(s)	R/W	Default	Description
31:24	R/W	0	Vadj2_softcon_curv1_ci, u8
23:12	R/W	0	Vadj2_softcon_curv1_b, u12
11:0	R/W	0	Vadj2_softcon_curv1_a, s12

**Table 9-2310 VPP\_VADJ2\_CURV\_3 0x32a8**

Bit(s)	R/W	Default	Description
31:13			Reserved
12:4	R/W	0	Vadj2_softcon_curv1_g, s9
3			Reserved
2:0	R/W	0	Vadj2_softcon_curv1_cs, u3

**Table 9-2311 VPP\_POST\_RGB\_CTRST 0x32a9**

Bit(s)	R/W	Default	Description
31:28			Reserved
27:16	R/W	1024	Post_rgb_ctrst: contrast for rgb, normalized 1024 as '1.0'
15:12			Reserved
11:2	R/W	64	Post_rgb_ctrst_blklvl: contrast black level to be subtract before and add back after the contrast gain operation
1	R/W	0	Post_rgbbst_en: 1 to enable the RGB_BST
0	R/W	1	Post_rgb_ctrst_prt: enable signal to protect saturation in rgb (no clipping) during contrast adjustment

**Table 9-2312 VPP\_POST\_RGB\_BRGHT 0x32aa**

Bit(s)	R/W	Default	Description
31:14			Reserved
13:2	R/W	0	Post_rgb_brght: brightness level in rgb domain
1	R/W	1	Post_rgb_brght_prt: enable signal to protect saturation in rgb (no clipping) during brightness adjustment
0	R/W	0	Post_rgb_ctrst_dlut_x2: Enable signal to do x2 to the dlut cells before subtracting from the normalized gain_max; 0:x1 1:x2

**Table 9-2313 VPP\_POST\_RGB\_DLUT\_0\_3 0x32ab**

Bit(s)	R/W	Default	Description
31:24	R/W	255	Post_rgbbst_dlut0: Differential gain to normalized gain_max to customized protection curve. e.g. [255 205 171 147 128 113 102 93 85 78 73 68] for protection of not boost for pixels larger than 240
23:16	R/W	205	Post_rgbbst_dlut1: same as Post_rgbbst_dlut0
15:8	R/W	171	Post_rgbbst_dlut2: same as Post_rgbbst_dlut0
7:0	R/W	147	Post_rgbbst_dlut3: same as Post_rgbbst_dlut0

**Table 9-2314 VPP\_POST\_RGB\_DLUT\_4\_7 0x32ac**

Bit(s)	R/W	Default	Description
31:24	R/W	128	Post_rgbbst_dlut4: same as Post_rgbbst_dlut0
23:16	R/W	113	Post_rgbbst_dlut5: same as Post_rgbbst_dlut0
15:8	R/W	102	Post_rgbbst_dlut6: same as Post_rgbbst_dlut0
7:0	R/W	93	Post_rgbbst_dlut7: same as Post_rgbbst_dlut0

**Table 9-2315 VPP\_POST\_RGB\_DLUT\_8\_11 0x32ad**

Bit(s)	R/W	Default	Description
31:24	R/W	85	Post_rgbbst_dlut8: same as Post_rgbbst_dlut0
23:16	R/W	78	Post_rgbbst_dlut9: same as Post_rgbbst_dlut0
15:8	R/W	73	Post_rgbbst_dlut10: same as Post_rgbbst_dlut0
7:0	R/W	68	Post_rgbbst_dlut11: same as Post_rgbbst_dlut0

**Table 9-2316 VPP\_POST\_MATRIX\_SAT 0x32c1**

Bit(s)	R/W	Default	Description
2	R/W	85	Sato_en
1	R/W	78	Sati_en
0	R/W	73	Misc_sat_en

### 9.2.3.46 3D LUT Registers

Table 9-2317 3D LUT VPP\_LUT3D\_CTRL 0x39d0

Bit(s)	R/W	Default	Description
9:8	R/W	0	Gated clock control
7	R/W		reserved
6:4	R/W		reg_lut3d_extnd_en: enable to set LUT value of 1023 to value 1024.
3	R/W		reserved
2	R/W	0	1 to shadow the "reg_lut3d_enable" by VSYNC
1	R/W		reserved
0	R/W	0	reg_lut3d_enable: 1 to enable 3D LUT

Table 9-2318 VPP\_LUT3D\_CBUS2RAM\_CTRL 0x39d1

Bit(s)	R/W	Default	Description
0	R/W	0	1 to enable CBUS to configure the LUT3D RAMs, 0 for in normal working status.

Table 9-2319 VPP\_LUT3D\_RAM\_ADDR 0x39d2

Bit(s)	R/W	Default	Description
32	R/W	0	LUT3D RAMs Address port

Table 9-2320 VPP\_LUT3D\_RAM\_DATA 0x39d3

Bit(s)	R/W	Default	Description
32	R/W	0	LUT3D RAMs data port

### 9.2.3.47 HDMITX Registers

Accessing HDMITX Top-Level and TX Controller IP registers is by directly accessing memory addresses. Due to the difference between the data width of Top-level register and IP register – Top-level 4-byte wide and IP register 1-byte wide, below list the correct ways to access Top-level and IP registers.

**To access Top-level registers:**

```
#define HDMITX_TOP_BASE_OFFSET      0xff608000
#define HDMITX_TOP_REVOCMEM_ADDR_S  0x2000
#define HDMITX_TOP_REVOCMEM_ADDR_E  0x365E
```

```
void hdmitx_wr_only_TOP (uint32_t addr, uint32_t data) {
if ((addr >= HDMITX_TOP_REVOCMEM_ADDR_S) &&
```

```

(addr <= HDMITX_TOP_REVOCMEM_ADDR_E) {
    *(volatile uint8_t*)(HDMITX_TOP_BASE_OFFSET+addr) = (uint8_t)(data&0xff);
} else {
    *(volatile uint32_t*)(HDMITX_TOP_BASE_OFFSET+addr) = (data);
}
}
}

```

```

uint32_t hdmitx_rd_TOP (uint32_t addr) {
    uint32_t data;
    if ((addr >= HDMITX_TOP_REVOCMEM_ADDR_S) &&
        (addr <= HDMITX_TOP_REVOCMEM_ADDR_E)) {
        data = (uint32_t)*((volatile uint8_t*)(HDMITX_TOP_BASE_OFFSET+addr));
    } else {
        data = *(volatile uint32_t*)(HDMITX_TOP_BASE_OFFSET+addr);
    }
    return (data);
}

```

**To write to an HDCP2.2 IP register:**

```

*((volatile uint32_t *) (ELP_ESM_HPI_REG_BASE+addr)) = data;

```

**Table 9-2321 HDCP2.2 IP register base address**

Absolute Address	Address Mnemonic	Description
0xffe01000	ELP_ESM_HPI_REG_BASE	Address base to HDCP2.2 IP register access.

**Table 9-2322 HDMITX Top-Level Registers**

Addr	Name	RW	Function
0x000<<2	HDMITX_TOP_SW_RESET	RW	Software reset sub-modules.
0x001<<2	HDMITX_TOP_CLK_CNTL	RW	Clock gating and inversion.
0x002<<2	HDMITX_TOP_HPD_FILTER	RW	HPD and RxSense input glitch filter.
0x003<<2	HDMITX_TOP_INTR_MASKN	RW	Interrupt mask.
0x004<<2	HDMITX_TOP_INTR_STAT	RW	Interrupt status.
0x005<<2	HDMITX_TOP_INTR_STAT_CLR	W	Interrupt clear.
0x006<<2	HDMITX_TOP_BIST_CNTL	RW	Build-In Self Test(BIST) control.
0x007<<2	HDMITX_TOP_SHIFT_PTTN_012	RW	Shift pattern for BIST.

Addr	Name	RW	Function
0x008<<2	HDMITX_TOP_SHIFT_PTTN_345	RW	Shift pattern for BIST.
0x009<<2	HDMITX_TOP_SHIFT_PTTN_67	RW	Shift pattern for BIST.
0x00A<<2	HDMITX_TOP_TMDS_CLK_PTTN_01	RW	TMDS clock pattern for generating /10 or /40 rate clock.
0x00B<<2	HDMITX_TOP_TMDS_CLK_PTTN_23	RW	TMDS clock pattern for generating /10 or /40 rate clock.
0x00C<<2	HDMITX_TOP_TMDS_CLK_PTTN_CNTL	RW	TMDS clock pattern for generating /10 or /40 rate clock.
0x00D<<2	HDMITX_TOP_REVOC-MEM_STAT	RW	Revocmem status
0x00E<<2	HDMITX_TOP_STAT0	RW	Status.
0x010<<2	HDMITX_TOP_SKP_CNTL_STAT	RW	SKP interface control for HDCP2.2.
0x011<<2	HDMITX_TOP_NONCE_0	W	Nonce[31:0] for HDCP2.2.
0x012<<2	HDMITX_TOP_NONCE_1	W	Nonce[63:32] for HDCP2.2.
0x013<<2	HDMITX_TOP_NONCE_2	W	Nonce[95:64] for HDCP2.2.
0x014<<2	HDMITX_TOP_NONCE_3	W	Nonce[127:96] for HDCP2.2.
0x015<<2	HDMITX_TOP_PKF_0	W	PKF[31:0] for HDCP2.2.
0x016<<2	HDMITX_TOP_PKF_1	W	PKF[63:32] for HDCP2.2.
0x017<<2	HDMITX_TOP_PKF_2	W	PKF[95:64] for HDCP2.2.
0x018<<2	HDMITX_TOP_PKF_3	W	PKF[127:96] for HDCP2.2.
0x019<<2	HDMITX_TOP_DUK_0	W	DUK [31:0] for HDCP2.2.
0x01A<<2	HDMITX_TOP_DUK_1	W	DUK [63:32] for HDCP2.2.
0x01B<<2	HDMITX_TOP_DUK_2	W	DUK [95:64] for HDCP2.2.
0x01C<<2	HDMITX_TOP_DUK_3	W	DUK [127:96] for HDCP2.2.
0x01D<<2	HDMITX_TOP_INFILTER	RW	DDC and CEC input glitch filter control.
0x01E<<2	HDMITX_TOP_NSEC_SCRATCH	RW	Scratch register for non-secure access.
0x01F<<2	HDMITX_TOP_SEC_SCRATCH	RW	Scratch register for secure access.
0x020<<2	HDMITX_TOP_EMP_CNTL0	RW	EMP control.
0x021<<2	HDMITX_TOP_EMP_CNTL1	RW	EMP control.
0x022<<2	HDMITX_TOP_EMP_MEMADDR_START	RW	Mem addr pointer for EMP.
0x023<<2	HDMITX_TOP_EMP_STAT0	R	EMP status.

Addr	Name	RW	Function
0x024<<2	HDMITX_TOP_EMP_STAT1	R	EMP status.
0x025<<2	HDMITX_TOP_AXI_ASYNC_CNTL0	RW	AXI async control.
0x026<<2	HDMITX_TOP_AXI_ASYNC_CNTL1	RW	AXI async control.
0x027<<2	HDMITX_TOP_AXI_ASYNC_STAT0	R	AXI async status.
0x028<<2	HDMITX_TOP_I2C_BUSY_CNT_MAX	RW	Max I2C idle time after I2C Start.
0x029<<2	HDMITX_TOP_I2C_BUSY_CNT_STAT	RW	I2C idle time status.
0x02A<<2	HDMITX_TOP_HDCP22_BSOD	RW	HDCP22 BSOD override control.
0x02B<<2	HDMITX_TOP_DDC_CNTL	RW	DDC pull down by SW.
0x030<<2	HDMITX_TOP_DISABLE_NULL	RW	NULL packet disable control.
0x2000	HDMITX_TOP_REVOC_MEM_ADDR_S	RW	Map to third party's IP internal Revoc MEM start address.
0x365E	HDMITX_TOP_REVOC_MEM_ADDR_E	RW	Map to third party's IP internal Revoc MEM end address.

Table 9-2323 HDMITX\_TOP\_SW\_RESET

Bit	R/W	Default	Description
31:8	R	0	Reserved
15:10	RW	0x3f	Reserved
9	RW	0	sw_reset_i2c: to reset third party IP's I2C module. 0=Release from reset; 1=Apply reset.
8	RW	1	sw_reset_axiarb: to reset AXI arbiter between HDCP22 and EMP. 0=Release from reset; 1=Apply reset.
7	RW	1	sw_reset_emp: to reset EMP block. 0=Release from reset; 1=Apply reset.
6	RW	1	sw_reset_ft: to reset DDC & CEC input glitch filter. 0=Release from reset; 1=Apply reset.
5	RW	1	sw_reset_hdcp22: to reset HDCP2.2 IP. 0=Release from reset; 1=Apply reset.
4	RW	1	sw_reset_phyif: to reset PHY interface. 0=Release from reset; 1=Apply reset.
3	RW	1	sw_reset_intr: to reset interrupt block. 0=Release from reset; 1=Apply reset.
2	RW	1	sw_reset_mem: to reset KSV/REVOC mem. 0=Release from reset; 1=Apply reset.

Bit	R/W	Default	Description
1	RW	1	sw_reset_rnd: to reset random number interface to HDCP. 0=Release from reset; 1=Apply reset.
0	RW	1	sw_reset_core: To reset TX Controller IP. 0=Release from reset; 1=Apply reset.

Table 9-2324 HDMITX\_TOP\_CLK\_CNTL

Bit	R/W	Default	Description
31	RW	0	free_clk_en: 0= Enable clock gating for power saving; 1= Disable clock gating, enable free-run clock.
30:13	RW	0	Reserved
12	RW	0	i2s_ws_inv: 1= Invert i2s_ws.
11	RW	0	i2s_clk_inv: 1= Invert i2s_clk.
10	RW	0	spdif_clk_inv: 1= Invert spdif_clk.
9	RW	0	tmds_clk_inv: 1= Invert tmds_clk.
8	RW	0	pixel_clk_inv: 1= Invert pixel_clk.
7	RW	0	hdcp22_skpclock_en: 1= Enable skpclock to HTX_HDCP2.2 IP.
6	RW	0	hdcp22_esmclk_en: 1= Enable esmclk to HTX_HDCP2.2 IP.
5	RW	0	hdcp22_tmdsclk_en: 1= Enable tmds_clk to HDCP2.2 IP.
4	RW	0	Reserved.
3	RW	0	i2s_clk_en: 1= Enable i2s_clk.
2	RW	0	spdif_clk_en: 1= Enable spdif_clk.
1	RW	0	tmds_clk_en: 1= Enable tmds_clk.
0	RW	0	pixel_clk_en: 1= Enable pixel_clk.

Table 9-2325 HDMITX\_TOP\_HPD\_FILTER

Bit	R/W	Default	Description
31:16	R	0	Reserved
31:28	RW	0	rxsense_glitch_width: Filter out glitch $\leq$ rxsense_glitch_width.
27:16	RW	0	rxsense_valid_width: Filter out width $\leq$ rxsense_valid_width * 1024.

Bit	R/W	Default	Description
15:12	RW	0	hpd_glitch_width: Filter out glitch $\leq$ hpd_glitch_width.
11:0	RW	0	hpd_valid_width: Filter out width $\leq$ hpd_valid_width * 1024.

Interrupt MASKN, one bit per interrupt source. 0= Disable interrupt source; 1= Enable interrupt source.

**Table 9-2326 HDMITX\_TOP\_INTR\_MASKN**

Bit	R/W	Default	Description
31:9	R	0	Reserved
8	RW	0	hdcp_topology_err
7	RW	0	rxsense_fall
6	RW	0	rxsense_rise
5	RW	0	err_i2c_timeout
4	RW	0	hdcp22_rndnum_err
3	RW	0	nonce_rfrsh_rise
2	RW	0	hpd_fall
1	RW	0	hpd_rise
0	RW	0	TX Controller IP interrupt.

Interrupt status. For each bit of bit[8:0], write 1 to manually set the interrupt bit, read back the interrupt status.

**Table 9-2327 HDMITX\_TOP\_INTR\_STAT**

Bit	R/W	Default	Description
31	R	0	Shadowing TX Controller IP interrupt status flag.
30	R	0	Shadowing HDCP2.2 IP interrupt status flag.
29:9	R	0	Reserved
8	RW	0	hdcp_topology_err
7	RW	0	rxsense_fall
6	RW	0	rxsense_rise
5	RW	0	err_i2c_timeout
4	RW	0	hdcp22_rndnum_err
3	RW	0	nonce_rfrsh_rise
2	RW	0	hpd_fall
1	RW	0	hpd_rise
0	RW	0	TX Controller IP interrupt.

Interrupt status clear. For each bit, write 1 to clear the interrupt bit.



Table 9-2328 HDMITX\_TOP\_INTR\_STAT\_CLR

Bit	R/W	Default	Description
31:9	R	0	Reserved
8	W	0	hdcp_topology_err
7	W	0	rxsense_fall
6	W	0	rxsense_rise
5	W	0	err_i2c_timeout
4	W	0	hdcp22_rndnum_err
3	W	0	nonce_rfrsh_rise
2	W	0	hpd_fall
1	W	0	hpd_rise
0	W	0	TX Controller IP interrupt.

Table 9-2329 HDMITX\_TOP\_BIST\_CNTL

Bit	R/W	Default	Description
31:16	R	0	Reserved
15	RW	0	Reserved
14:12	RW	0	tmds_sel: 3'b000=Output zero; 3'b001=Output normal TMDS data; 3'b010=Output PRBS data; 3'b100=Output shift pattern.
11: 9	RW	0	shift_pttn_repeat: 0=New pattern every clk cycle; 1=New pattern every 2 clk cycles; ...; 7=New pattern every 8 clk cycles.
8	RW	0	shift_pttn_en: 1= Enable shift pattern generator; 0=Disable.
7:5	RW	0	Reserved
4: 3	RW	0	prbs_pttn_mode: 0=PRBS11; 1=PRBS15; 2=PRBS7; 3=PRBS31.
2:1	RW	0	prbs_pttn_width: 0=Idle; 1=Output 8-bit pattern; 2=Output 1-bit pattern; 3=Output 10-bit pattern.
0	RW	0	prbs_pttn_en: 1=Enable PRBS generator; 0=Disable.

Table 9-2330 HDMITX\_TOP\_SHIFT\_PTTN\_012

Bit	R/W	Default	Description
31:30	R	0	Reserved
29:20	RW	0	shift_pttn_data[59:50].
19:10	RW	0	shift_pttn_data[69:60].
9:0	RW	0	shift_pttn_data[79:70].

**Table 9-2331 HDMITX\_TOP\_SHIFT\_PTTN\_345**

Bit	R/W	Default	Description
31:30	R	0	Reserved
29:20	RW	0	shift_pttn_data[29:20].
19:10	RW	0	shift_pttn_data[39:30].
9:0	RW	0	shift_pttn_data[49:40].

**Table 9-2332 HDMITX\_TOP\_SHIFT\_PTTN\_67**

Bit	R/W	Default	Description
31:20	R	0	Reserved
19:10	RW	0	shift_pttn_data[9:0].
9:0	RW	0	shift_pttn_data[19:10].

**Table 9-2333 HDMITX\_TOP\_TMDS\_CLK\_PTTN\_01**

Bit	R/W	Default	Description
31:26	R	0	Reserved
25:16	RW	0	tmds_clk_pttn[19:10].
15:10	R	0	Reserved
9:0	RW	0	tmds_clk_pttn[9:0].

**Table 9-2334 HDMITX\_TOP\_TMDS\_CLK\_PTTN\_23**

Bit	R/W	Default	Description
31:26	R	0	Reserved
25:16	RW	0	tmds_clk_pttn[39:30].
15:10	R	0	Reserved
9:0	RW	0	tmds_clk_pttn[29:20].

**Table 9-2335 HDMITX\_TOP\_TMDS\_CLK\_PTTN\_CNTL**

Bit	R/W	Default	Description
31:2	R	0	Reserved
1	RW	0	shift_tmds_clk_pttn: 1=Enable shifting clk pattern, used when TMDS CLK rate = TMDS character rate /4.
0	W	0	load_tmds_clk_pttn: Write this bit to 1 to load tmds_clk_pttn to HW. Always read back 0.

**Table 9-2336 HDMITX\_TOP\_REVOCMEM\_STAT**

Bit	R/W	Default	Description
31:2	R	0	Reserved
1	RW	0	revocmem_rd_fail: Read back 1 to indicate Host read REVOC MEM failure, Reading this register automatically clear the failure flag.
0	RW	0	revocmem_wr_fail: Read back 1 to indicate Host write REVOC MEM failure, Reading this register automatically clear the failure flag.

**Table 9-2337 HDMITX\_TOP\_STAT0**

Bit	R/W	Default	Description
31:2	R	0	Reserved
1	R	0	filtered RxSense status: 0= RxSense low; 1= RxSense high.
0	R	0	filtered HPD status: 0= HPD low; 1= HPD high.

**Table 9-2338 HDMITX\_TOP\_SKP\_CNTL\_STAT**

Bit	R/W	Default	Description
31	R	0	Status of nonce_vld signal.
30:4	R	0	Reserved
3	RW	0	rndnum_hdcp22: 0=Random number generator if enabled for hdcp1.4; 1= Random number generator if enabled for hdcp2.2.
2	RW	0	DUK_vld:Set to 1 once DUK is written.
1	RW	0	PKF_vld:Set to 1 once PKF is written.
0	RW	0	nonce_hw_en: 1=Use HW nonce; 0=Use SW nonce from reg HDMITX_TOP_NONCE_0/1/2/3.

**Table 9-2339 HDMITX\_TOP\_NONCE\_0**

Bit	R/W	Default	Description
31:0	W	0	nonce[31:0]

**Table 9-2340 HDMITX\_TOP\_NONCE\_1**

Bit	R/W	Default	Description
31:0	W	0	nonce[63:32]

Table 9-2341 HDMITX\_TOP\_NONCE\_2

Bit	R/W	Default	Description
31:0	W	0	nonce[95:64]

Table 9-2342 HDMITX\_TOP\_NONCE\_3

Bit	R/W	Default	Description
31:0	W	0	nonce[127:96]

Table 9-2343 HDMITX\_TOP\_PKF\_0

Bit	R/W	Default	Description
31:0	W	0	PKF[31:0]

Table 9-2344 HDMITX\_TOP\_PKF\_1

Bit	R/W	Default	Description
31:0	W	0	PKF[63:32]

Table 9-2345 HDMITX\_TOP\_PKF\_2

Bit	R/W	Default	Description
31:0	W	0	PKF[95:64]

Table 9-2346 HDMITX\_TOP\_PKF\_3

Bit	R/W	Default	Description
31:0	W	0	PKF[127:96]

Table 9-2347 HDMITX\_TOP\_DUK\_0

Bit	R/W	Default	Description
31:0	W	0	DUK[31:0]

Table 9-2348 HDMITX\_TOP\_DUK\_1

Bit	R/W	Default	Description
31:0	W	0	DUK[63:32]

Table 9-2349 HDMITX\_TOP\_DUK\_2 Register

Bit	R/W	Default	Description
31:0	W	0	DUK[95:64]

Table 9-2350 HDMITX\_TOP\_DUK\_3 Register

Bit	R/W	Default	Description
31:0	W	0	DUK[127:96]

Table 9-2351 HDMITX\_TOP\_INFILTER Register

Bit	R/W	Default	Description
31:27	RW	0	Reserved
26:24	RW	0	For DDC infilter: filter internal clock divider. 0=No divide; 1=Divide by 2; 2=Divide by 3; ... 7=Divide by 8.
23:16	RW	0	For DDC infilter: sampling clock divider. 0=No divide; 1=Divide the filter sampling clock by 2; 2=Divide the filter sampling clock by 3; ... 255=Divide the filter sampling clock by 256;
15:0	RW	0	Reserved

Table 9-2352 HDMITX\_TOP\_NSEC\_SCRATCH Register

Bit	R/W	Default	Description
31:0	RW	0	Scratch register that can be used for either secure or non-secure reg access.

Table 9-2353 HDMITX\_TOP\_SEC\_SCRATCH Register

Bit	R/W	Default	Description
31:0	RW	0	Scratch register that can be used for secure reg access only.

Table 9-2354 HDMITX\_TOP\_EMP\_CNTL0 Register

Bit	R/W	Default	Description
31:16	RW	0	Empacketsinframe. Number of EMPs to send for the next frame.
15:8	RW	0	Empstartlatency. Defines the number of lines to wait after End-Of-Field, to start sending EMP.
0	RW	0	emp_tx_en. 0=Disable Extended Metadata packet. 1=Enable Extended Metadata packet.

Table 9-2355 HDMITX\_TOP\_EMP\_CNTL1 Register

Bit	R/W	Default	Description
31:19	R	0	Reserved.
18:17	RW	0	emp_endian[1:0]. Bit[0]: 1=EMP data are stored as little Endian in DDR per 64-bit. 0=Big endian. Bit[1]: 1=For each 128-bit, swap high 64-bit to low 64-bit, and low 64-bit to high 64-bit. 0=No swap.

Bit	R/W	Default	Description
16	RW	0	emp_autoclr_ar_pending. If at the start of DDR read request for the current frame, there is still outstanding requests remaining from the previous frame, this bit defines whether to auto-clear DDR request state machine. 0=The current request will not start until the previous outstanding requests are cleared by normal operation. 1=The state machine is reset and previous outstanding requests are cancelled. The current request starts immediately.
15:0	RW	128	emp_sampleline. All EMP control registers are buffered internally, at the time defined by this field – the number of lines after Vsync rise. Before this time the EMP control registers does not take effect.

Table 9-2356 HDMITX\_TOP\_EMP\_MEMADDR\_START Register

Bit	R/W	Default	Description
31:0	RW	0	Start address of EMP memory pointer for next frame.

Table 9-2357 HDMITX\_TOP\_EMP\_STAT0 Register

Bit	R/W	Default	Description
31:30	RW	0	emp_err[1:0]. Error status of AXI activity. Write 1 to each bit to clear. Bit[0]: 1=AXI RID incorrect. Bit[1]: 1=AXI RRESP error.
29:27	R	0	Reserved.
26:24	R	0	emp_ar_state[2:0]: Status of DDR AXI Address Read state machine. 0=IDLE; 1=WAIT_FIFO_ROOM; 2=WAIT_ARREADY; 3=WAIT_PENDING; 4=DONE.
23:17	R	0	emp_fifo_count[6:0]. FIFO fill level for storing 128-bit DDR data, the result of reading EMP data from DDR.
16:0	R	0	emp_ar_pending. Number of DDR reads that are still outstanding, meaning request has been sent, but Data have yet to be received.

Table 9-2358 HDMITX\_TOP\_EMP\_STAT1 Register

Bit	R/W	Default	Description
31:16	R	0	empdone_cnt_buf [15:0]: Buffered number of EMP sent.
15:0	R	0	empdone_cnt[15:0]: Current number of EMP sent.

Table 9-2359 HDMITX\_TOP\_AXI\_ASYNC\_CNTL0 Register

Bit	R/W	Default	Description
31:16	R	0	Reserved.
15:8	RW	128	axi_async_waiting_limit[7:0].
7:5	R	0	Reserved.
4:3	RW	0	axi_urgent[1:0]: DDR request urgent level.
2	RW	0	axi_async_disable_clk.

Bit	R/W	Default	Description
			1=Disable clk to AXI-async module. 0=Enable clk.
1	RW	1	axi_async_auto_gclk_en. 1=Auto clk gate AXI-async module. 0=Free-run clk.
0	RW	1	axi_async_req_en. 1=Enable AXI async interface between EMP's tmds_clk domain to AXI's esm_clk domain. If need to sent EMP, this bit must be enabled. 0=Disable.

Table 9-2360 HDMITX\_TOP\_AXI\_ASYNC\_CNTL1 Register

Bit	R/W	Default	Description
31:0	RW	32'h181-01810	axi_async_hold_num.

Table 9-2361 HDMITX\_TOP\_AXI\_ASYNC\_STAT0 Register

Bit	R/W	Default	Description
31:1	R	0	Reserved.
0	RW	1	axi_async_chan_idle.

Table 9-2362 HDMITX\_TOP\_I2C\_BUSY\_CNT\_MAX Register

Bit	R/W	Default	Description
31:0	RW	0xffffffff	i2c_busy_cnt_max. After I2C Start bit, if I2C bus is static for more than i2c_busy_cnt_max number of cycles, an error interrupt will happen.

Table 9-2363 HDMITX\_TOP\_I2C\_BUSY\_CNT\_STAT Register

Bit	R/W	Default	Description
31:0	R	0	i2c_busy_cnt. Reflect the number of idle cycles after the I2C Start bit, for the latest I2C transaction.

Table 9-2364 HDMITX\_TOP\_HDCP22\_BSOD Register

Bit	R/W	Default	Description
31:26	R	0	Reserved.
25	RW	0	hdc22_no_bsod. 1=Do not use BSOD to override, no matter from FW or SW. 0=Use the BSOD, original behaviour.
24	RW	0	hdc22_bsod_override. 1=Override BSOD value with hdc22_bsod_val. 0=Use the original BSOD value from ESM FW.
23:0	RW	0x8000-80	hdc22_bsod_val.

Table 9-2365 HDMITX\_TOP\_DDC\_CNTL Register

Bit	R/W	Default	Description
31:2	R	0	Reserved.
1	RW	1	DSDA pull down. 0=Pull down DSDA. 1=No pull down.
0	RW	1	DSCL pull down. 0=Pull down DSCL. 1=No pull down.

**Note**

To disable NULL, set to 3'b111; To enable NULL, set to 3'b110; To revert to original behaviour, set to 3'b000. Bit[2:1] must be stable throughout operation. Bit[0] can be changed dynamically.

Table 9-2366 HDMITX\_TOP\_DISABLE\_NULL Register

Bit	R/W	Default	Description
31:3	R	0	Reserved.
2	RW	1	Clear/Set_AVMUTE delay control. 0=Original behaviour. 1=Delay Clear/Set_AVMUTE by 10-cycle.
1	RW	1	Path delay match control. 0=Original behaviour. 1=Delay control/data path by 10-cycle. Must set 1 to disable NULL.
0	RW	0	NULL packet disable control. 0=Enable NULL. Original behaviour. 1=Disable NULL.

Table 9-2367 ih\_fc\_stat2 0x102

Bits	Name	Memory Access	Description
3	EMP	RW	Active after successful transmission of a total of N packets through DDR-EMP interface. N is programmed by HDMITX_TOP_EMP_CNTL0[31:16]. Value After Reset: 0
2	DRM	RW	Active after successful transmission of an DRM InfoFrame packet. Value After Reset: 0

Table 9-2368 ih\_mute\_fc\_stat2 0x182

Bits	Name	Memory Access	Description
3	EMP	RW	When set to 1, mutes ih_fc_stat2[3]. Value After Reset: 1
2	DRM	RW	When set to 1, mutes ih_fc_stat2[2]. Value After Reset: 1

Table 9-2369 fc\_datauto3 0x10b7

Bits	Name	Memory Access	Description
6	DRM_auto	RW	Enables DRM packet insertion Value After Reset: 1



Table 9-2370 fc\_rdrb12 0x10c4

Bits	Name	Memory Access	Description
7:4	Re-served.		
3:0	DRMframeinterpolation	RW	DRM frame interpolation Value After Reset: 0

Table 9-2371 fc\_rdrb13 0x10c5

Bits	Name	Memory Access	Description
7:4	DRMpacketsinframe	RW	DRM packets per frame Value After Reset: 0
3:0	DRMpacketlinespacing	RW	DRM packets line spacing Value After Reset: 0

Table 9-2372 fc\_mask2 0x10da

Bits	Name	Memory Access	Description
3	EMP	RW	Mask bit for FC_INT2.EMP interrupt bit Value After Reset: 1
2	DRM	RW	Mask bit for FC_INT2.DRM interrupt bit Value After Reset: 1

Table 9-2373 fc\_packet\_tx\_en 0x10e3

Bits	Name	Memory Access	Description
7	DRM_tx_en	RW	DRM transmission control 1: Transmission enabled 0: Transmission disabled Value After Reset: 0

Table 9-2374 fc\_drm\_hb01 0x1168

Bits	Name	Memory Access	Description
7:0	fc_drm_hb0	RW	Frame composer DRM Packet Header Register 1 Value After Reset: 0

Table 9-2375 fc\_drm\_hb02 0x1169

Bits	Name	Memory Access	Description
7:0	fc_drm_hb1	RW	Frame composer DRM Packet Header Register 2 Value After Reset: 0

Table 9-2376 fc\_drm\_pb[0:26] 0x116a+(i\*0x1)

Bits	Name	Memory Access	Description
7:0	fc_drm_pb	RW	Frame composer DRM Packet Body Register Array Value After Reset: 0

Table 9-2377 fc\_dbgforce 0x1200

Bits	Name	Memory Access	Description
7	forcewoo	RW	Per SolvNet case8000767326: 0=Use bug fix method suggested in case8000767326. 1=Revert to original RTL. Not recommended. Value After Reset: 0

Table 9-2378 a\_hdcpcfg1 0x5001

Bits	Name	Memory Access	Description
6	hdcp14_no_short_read	RW	1=Read Ri' with explicit address=0x08. 0=Original IP behaviour – short-read. Value After Reset: 0
5	hdcp14_delmatch	RW	1=Match path delays between HDCP14 path and non-HDCP path. 0=Original IP behaviour. Value After Reset: 0

Table 9-2379 a\_bstatus\_hi 0x5017

Bits	Name	Memory Access	Description
7:0	Bstatus [15:8]	R	HDCP BSTATUS[15:8]. Value After Reset: 0

Table 9-2380 a\_bstatus\_lo 0x5018

Bits	Name	Memory Access	Description
7:0	Bstatus [7:0]	R	HDCP BSTATUS[7:0]. Value After Reset: 0

Table 9-2381 hdcp22reg\_id 0x7900

Bits	Name	Memory Access	Description
7	hdcp22_not_capable	R	1=HDCP22 Not capable. Value After Reset: 0

**Table 9-2382 hdcp22reg\_ctrl 0x7904**

Bits	Name	Memory Access	Description
7	hdcp_ byp_ delmatch	RW	1=Match path delays between HDCP path and non-HDCP path. 0=Original IP behaviour. Value After Reset: 0
6	hdcp22_ 14_ delmatch	RW	1=Match path delays between HDCP22 path and HDCP14 path. 0=Original IP behaviour. Value After Reset: 0

**Table 9-2383 hdcp22reg\_sts 0x7908**

Bits	Name	Memory Access	Description
7	Hdcp22_ capable	R	1=HDCP22 capable. Value After Reset: 0
6	hdcp22_ auth_lost	R	1=HDCP22 authentication lost. Value After Reset: 0
5	hdcp22_ authenti- cated	R	1=HDCP22 authenticated. Value After Reset: 0
4	hdcp22_ auth_fail	R	1=HDCP22 authentication failed. Value After Reset: 0

**Table 9-2384 i2cm\_softrstz 0x7e09**

Bits	Name	Memory Access	Description
1	softrst_ idle_cnt_ en	RW	Active by writing a zero and auto cleared to one in the following cycle. Do this to re-enable IDLE counter again. The counter maybe frozen due to some mis-operation from RX on the I2C bus. Value After Reset: 1

For below registers, the base address is 0xFF63C000.

Each register final address = BASE + address \* 4

**Table 9-2385 HHI\_HDMI\_PHY\_CNTL0 0xE8**

Bit(s)	R/W	Default	Description
31~16	R/W	0	HDMI_CTL1
15~0	R/W	0	HDMI_CTL0

**Table 9-2386 HHI\_HDMI\_PHY\_CNTL1 0xE9**

Bit(s)	R/W	Default	Description
31:30	R/W	0	New_prbs_mode
29:28	R/W	0	New_prbs_prbsmode
27	R/W	0	New_prbs_sel
26	R/W	0	New_prbs_en

Bit(s)	R/W	Default	Description
25:24	R/W	3	Ch3_swap: 0:ch0/1:ch1/2:ch2/3:ch3
23:22	R/W	2	Ch2_swap: 0:ch0/1:ch1/2:ch2/3:ch3
21:20	R/W	1	Ch1_swap: 0:ch0/1:ch1/2:ch2/3:ch3
19:18	R/W	0	Ch0_swap: 0:ch0/1:ch1/2:ch2/3:ch3
17	R/W	0	BIT_INVERT
16	R/W	0	MSB_LSB_SWAP
15	R/W	0	Capture_add1
14	R/W	0	CAPTURE_CLK_GATE_EN
13	R/W	0	HDMI_TX_PRBS_EN: Set to 1 to enable the PRBS engine
12	R/W	0	HDMI_TX_PRBS_ERR_EN: Set to 1 to enable the error flag detector. Set to 0 to reset the error detection logic
11~8	R/W	0	HDMI_TX_SET_HIGH: Set each bit to 1 to set the HDMI pin high
7~4	R/W	0	HDMI_TX_SET_LOW: Set each bit to 0 to set the HDMI Pins low
3	R/W	0	HDMI_FIFO_WR_ENALBE
2	R/W	0	HDMI_FIFO_ENABLE
1	R/W	0	HDMI_TX_PHY_CLK_EN: Set to 1 to enable the HDMI TX PHY
0	R/W	0	HDMI_TX_PHY_SOFT_RESET: Set to 1 to reset the HDMI TX PHY

Table 9-2387 HHI\_HDMI\_PHY\_CNTL2 0xEA

Bit(s)	R/W	Default	Description
31~9	R	0	Reserved
8	R	0	Test error
7~0	R	0	HDMI_REGRD

Table 9-2388 HHI\_HDMI\_PHY\_CNTL3 0xEB

Bit(s)	R/W	Default	Description
31~16	R/W	0	hdmi_ctl3
15~0	R/W	0	hdmi_ctl2

Table 9-2389 HHI\_HDMI\_PHY\_CNTL4 0xEC

Bit(s)	R/W	Default	Description
[31:24]	R/W	0	New_prbs_err_thr
[21:20]	R/W	0	Dtest_sel
[19]	R/W	0	New_prbs_clr_ber_meter
[17]	R/W	0	New_prbs_freez_ber

Bit(s)	R/W	Default	Description
[16]	R/W	0	New_prbs_inverse_in
[15:14]	R/W	0	New_prbs_mode
[13:12]	R/W	0	New_prbs_prbs_mode
[11:0]	R/W	0	New_prbs_time_window

Table 9-2390 HHI\_HDMI\_PHY\_CNTL5 0xED

Bit(s)	R/W	Default	Description
[15:0]	R/W	0	hdmi_ctl4

Table 9-2391 HHI\_HDMI\_PHY\_STATUS 0xEE

Bit(s)	R/W	Default	Description
[29]	R		Prbs_enable
[28]	R		Test_err
[24]	R		New_prbs_pattern_nok
[20]	R		New_prbs_lock
[19:0]	R		New_prbs_ber_meter

# 10 Audio Path

The SoC integrates 3 TDM input/output interface, 1 SPDIF input, 2 SPDIF output interface, 1 PDM interface upto 8 channels, 4TODDR (FIFO) for transfer input data to DDR, 4 FRDDR (FIFO) for transfer data from DDR to output, 1 TDM LB and 1 SPDIF LB and 2Loopback for AEC, 2 HW resample for clock synchronization, 1 VAD voice wake up, and 1 clock locker detect difference of two clock. Below is the diagram for audio path.

Figure 10-1 Audio Path

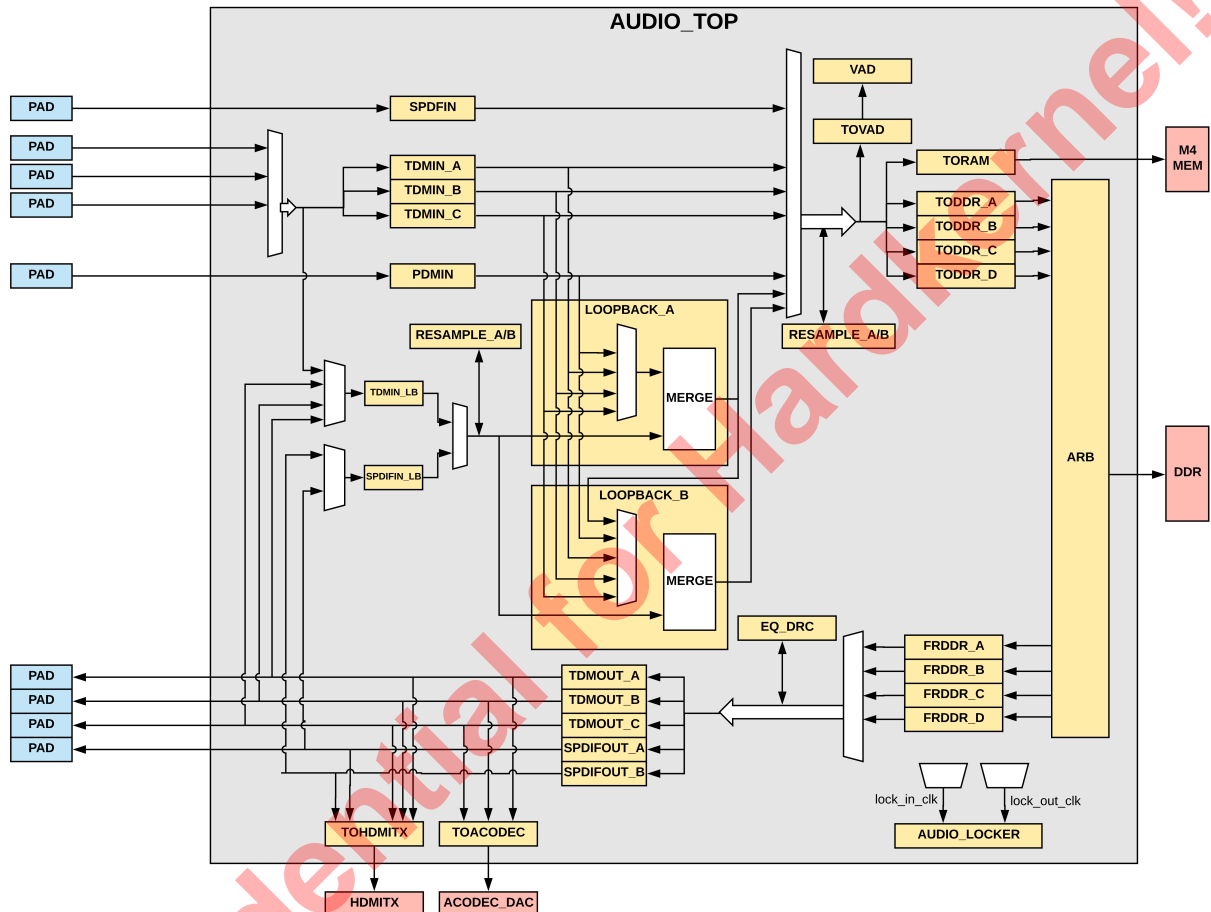

## 10.1 Audio Input

### 10.1.1 Overview

This section describes TDM input interface, SPDIF input interface PDM input interface and interface.

### 10.1.2 TDM Input Interface

TDM input interface works in the following way:

- All worked at tdm\_sclk before AFIFO,
- Output is worked at sysclk;
- Add skew control between lrclock and data;
- Detect rise or fall edge of lrclock and clear bit\_cnt/slot\_cnt;

- Shift 4 serial data in to 8 parallel register (max 32bits) ;
- Swap 8 parallel register to 8 sample data;
- Send 8 sample data out in serials by mask/mute configure;

Below is the diagram of TDM input interface.

Figure 10-2 TDM Input

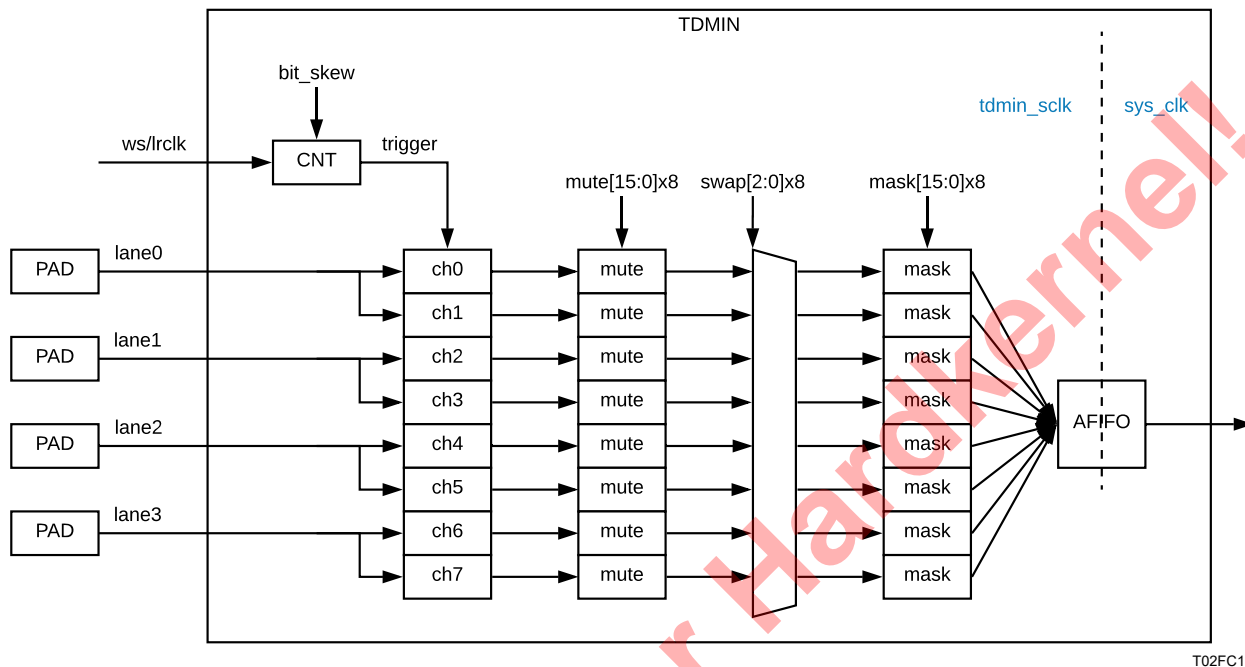

### 10.1.3 SPDIF Input Interface

SPDIF input interface works in the following way:

- All worked at spdifin\_clk before AFIFO;
- After AFIFO worked at sysclk;
- Detect frequency by rise or fall edge;
- Capture data to shift reg;
- Store data to sample L channel or R channel;
- Detect PaPb if it's IEC60937;

Below is the diagram of SPDIF input interface.

Figure 10-3 SPDIF Input

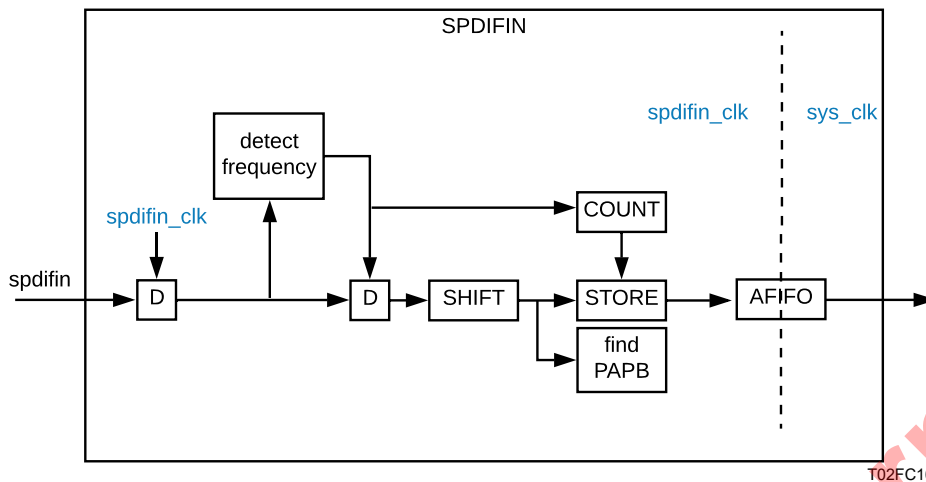

### 10.1.4 PDM

PDM input decimation filter is a highly programmable multistage decimation filter. It supports 4 inputs or 8 channel PDM digital microphone interface. Each channel contains one 9 stage CIC filter, 3 low power filters and a high pass filter. The PDM input bit rate is calculate with  $fs \cdot OSR$ . OSR can be 64, 128, 192 or 256.

CIC filter may have 3 to 9 CIC stages and the downsample rate also can be programable. There is a multiplier and shifter to adjust the result to match the accuracy and CIC bit width.

There are 3 low pass filters which shared a 336x24 Coefficient memory and a 336x28 data memory. That means these 3 filters can be configed upto 336 taps together. The coefficient memory need to be programmed through APB bus. For example, if the filter 1 contains 140 taps, filter 2 contains 32 taps, filter 3 contain 146 steps, the filter 1 coefficient will use 0~139 of the coefficient memory address; the filter 2 coefficient will use 140~171 of coefficient memory address and the filter 3 coefficient will use 172~317 of the coefficient memory address. The filter stage controller will based on the downsample rate, filter taps and the rounding mode of each filter to arrange the filter.

The final high pass filter is used to filter the DC current.

Figure 10-4 PDM Decimation Filter

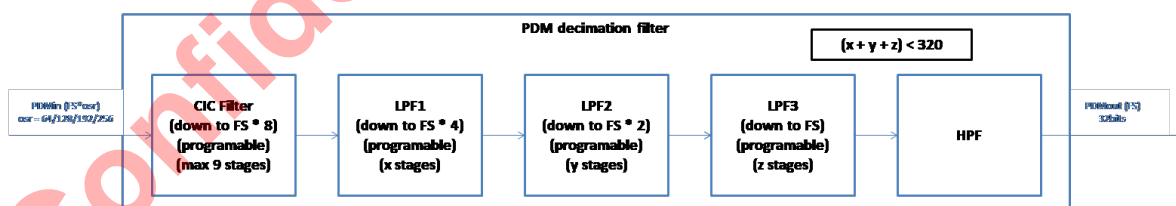
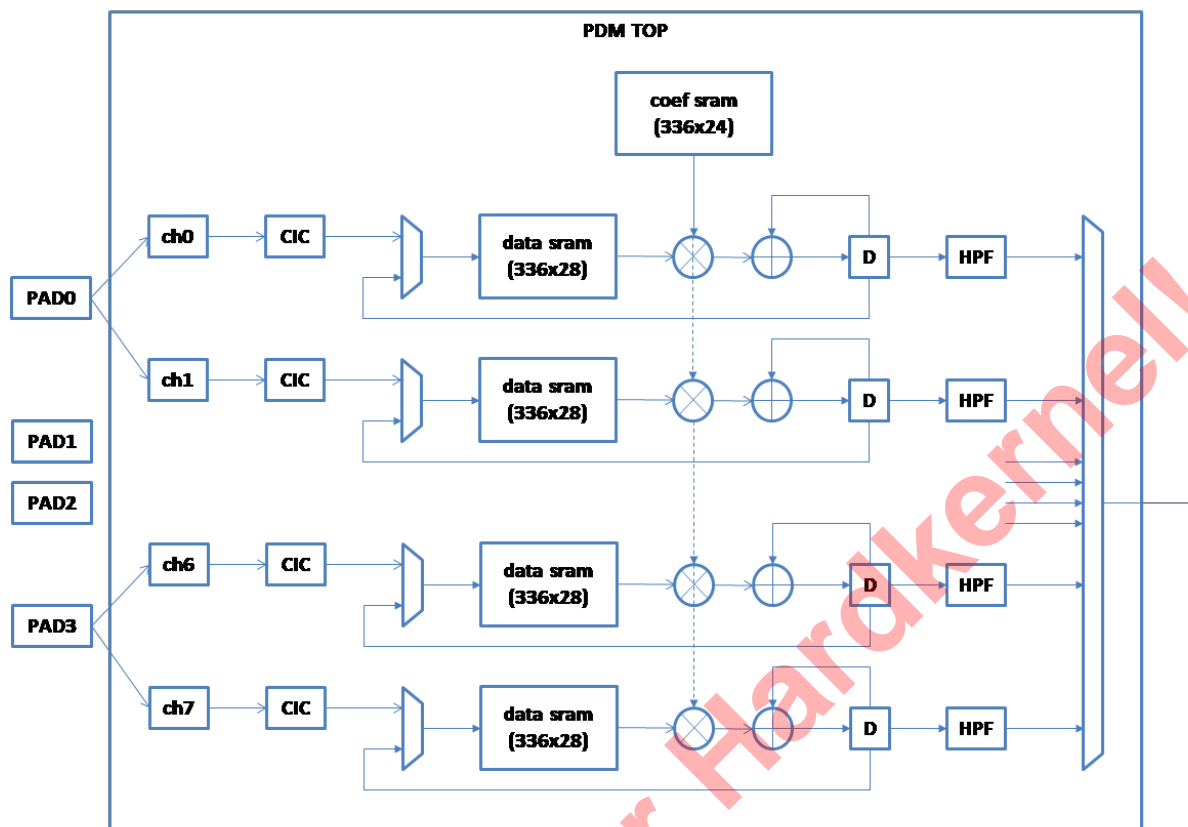



Figure 10-5 PDM Structure



## 10.2 Audio Output

### 10.2.1 Overview

This section describes TDM output interface, SPDIF output interface and audio REQ\_FRDDR submodule.

### 10.2.2 TDM Output Interface

TDM output interface works in the following way:

- All worked at tdm\_sclk;
- Detect sample valid by tdm\_lrcclk rise edge and clear bit\_cnt/slot\_cnt;
- Request data from FRDDR and store to 8 sample register;
- Swap 8 sample register;
- Shift send out data;

Below is the digram of TDM output interface.

Figure 10-6 TDM Output

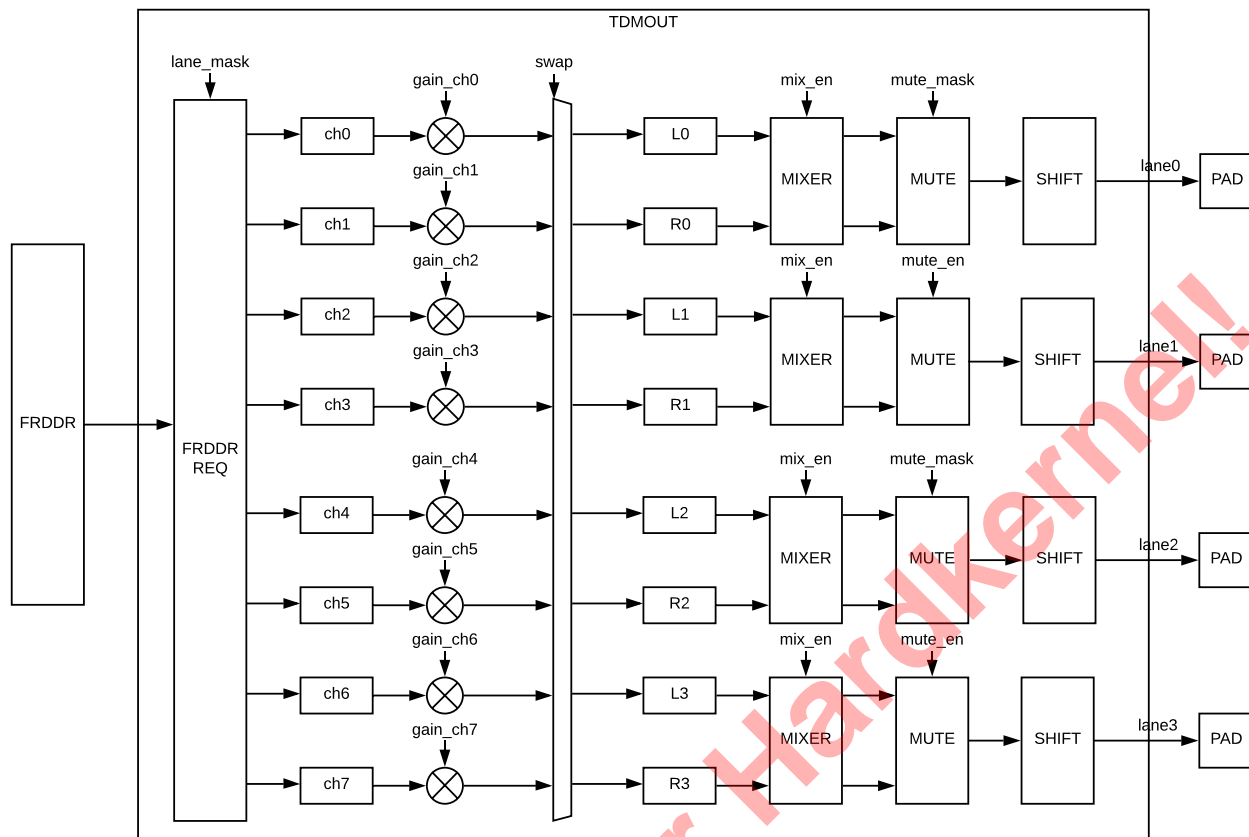

T02FC19

### 10.2.3 SPDIF Output Interface

The SPDIF output interface works in the following way:

- All worked at spdifout clk;
- Request data from FRDDR and store to sample L0/R0
- Select data by bit\_cnt/slot\_cnt and send out;

Below is the digram of SPDIF output interface.

Figure 10-7 SPDIF Output Interface

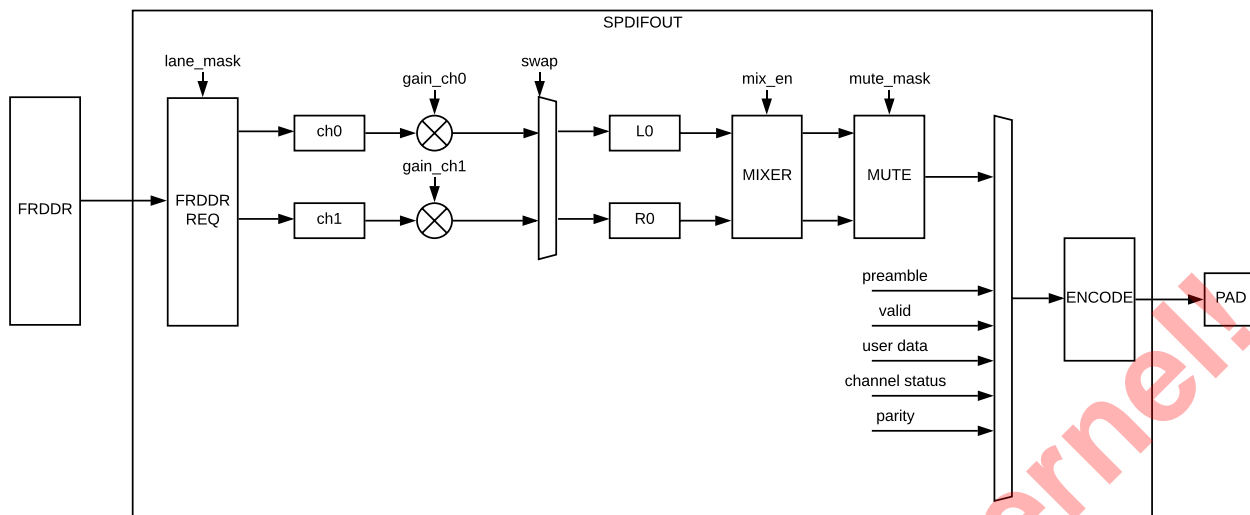

T02FC20

The SPDIF (encode) add same source select. The SPDIF out can be the same with i2s 0/1/2/3, and can select before or after eq/drc.

### 10.2.4 Audio REQ\_FRDDR

Audio Req\_Frddr transfers data from sys clock to out clock and change format in the following way;

- Wait for OUT enable and FRDDR initial done;
- Request first time and fill 8 sample;
- When received update data, it will send request to FRDDR and update 8 sample;

Below is a diagram of Audio REQ\_FRDDR.

Figure 10-8 Audio REQ\_FRDDR

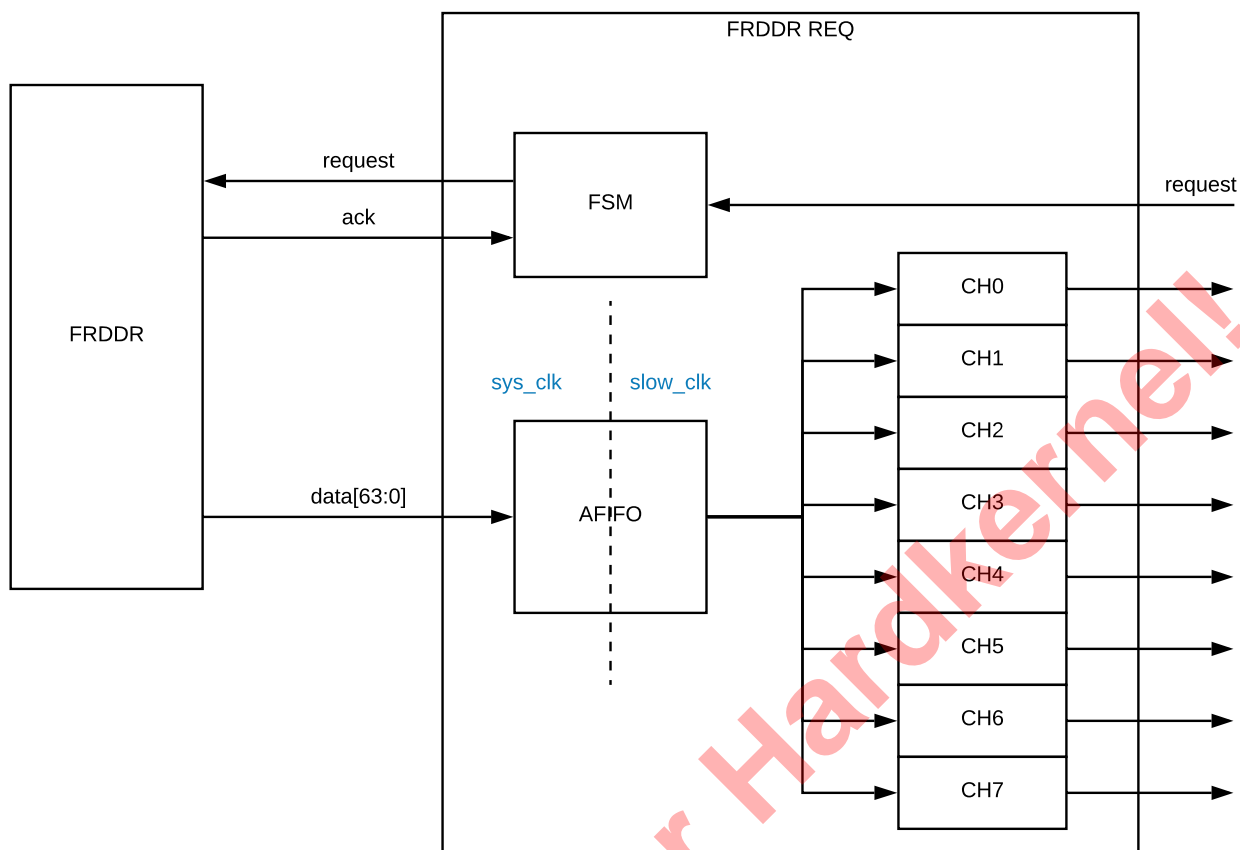

T02FC21

## 10.3 DDR Datapath

### 10.3.1 Overview

This part describes the datapath between audio module and DDR.

### 10.3.2 Audio TODDR

The SoC has 4 TODDR(FIFO), TODDR\_A's FIFO depth is 4096 x 64; B/C/D are 128 x 64. TODDR module works in the following way:

- All TODDR work at sysclk;
- Resample if need;
- Change format and package to 64 bits data by configuration;
- Write to fifo;
- Read data from fifo and send to DDR automatically by configuration;

Below is the Diagram of Audio TODDR.

Figure 10-9 Audio TODDR

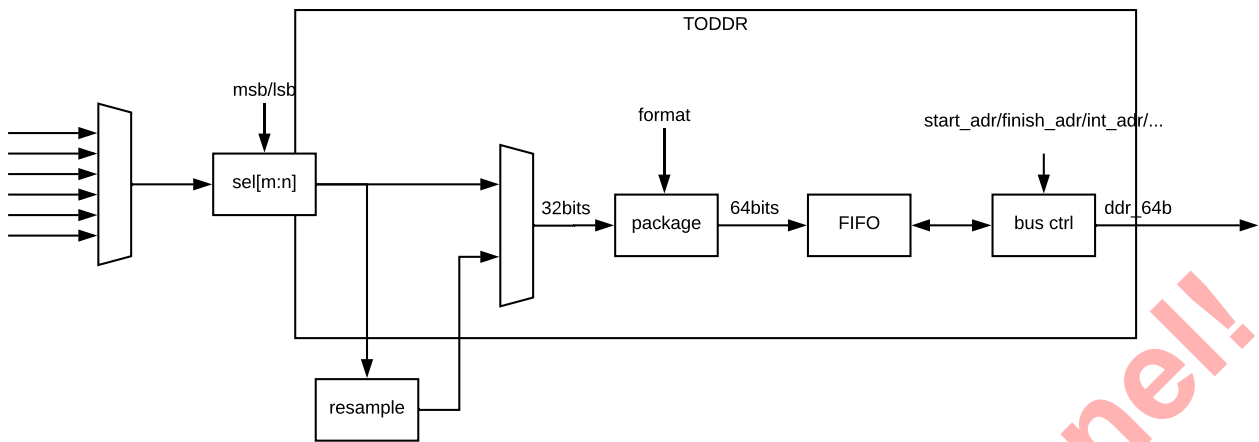

T02FC22

### 10.3.3 Audio FRDDR

The SoC has 4 FRDDR(FIFO), FRDDR\_A's FIFO depth is 256 x 64, B/C/D are 128 x 64;

- All FRDDR work at sysclk;
- When enable FRDDR, it will fill FIFO from DDR first;
- When FRDDR receive request, it will read data from fifo and send out;
- FRDDR will fill FIFO automatically by configure;

Below is the Diagram of Audio FRDDR.

Figure 10-10 Audio FRDDR

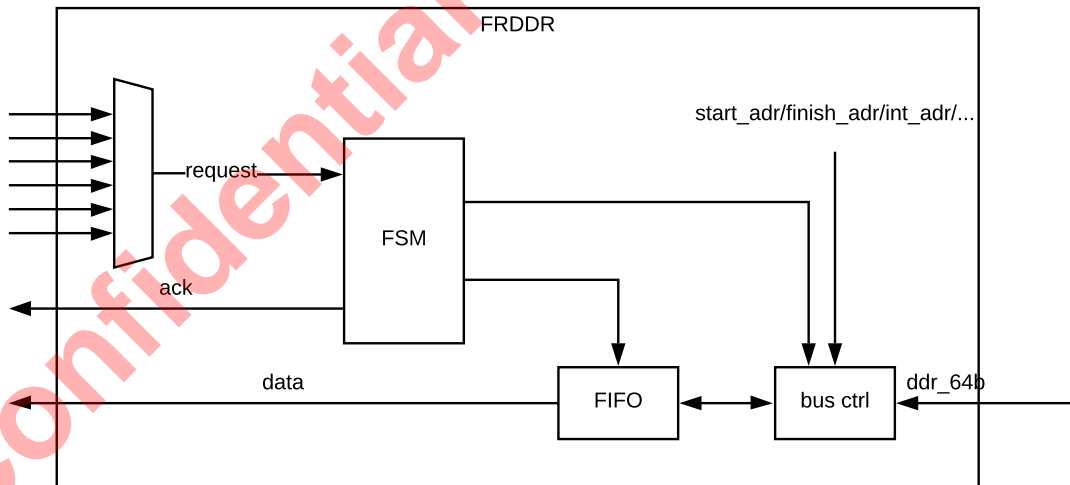

T02FC23

### 10.4 Audio TORAM

TORAM is similar as TODDR, just use RAM interface.

## 10.5 Audio Loopback

TDMIN\_LB can receive one TDMOUT or SPDIFOUT, it can merge with one TDMIN/SPDIFIN/PDMIN in the following way:

- Store one source to temp register;
- When another source arrived, send out direct;
- When finished, send out temp register;

Below is the diagram of audio loopback datapath.

Figure 10-11 Audio Loopback Datapath

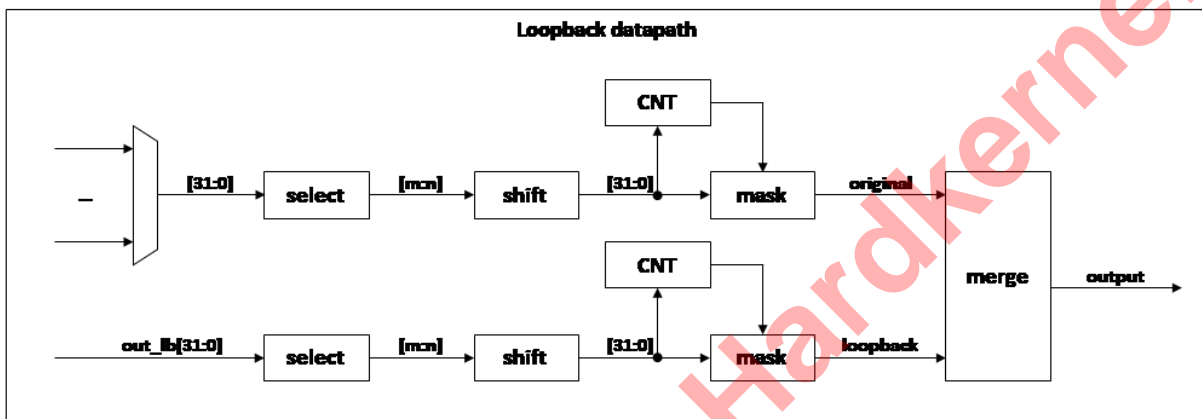

Audio loopback wave form are shown below.

Figure 10-12 Audio Loopback Waveform

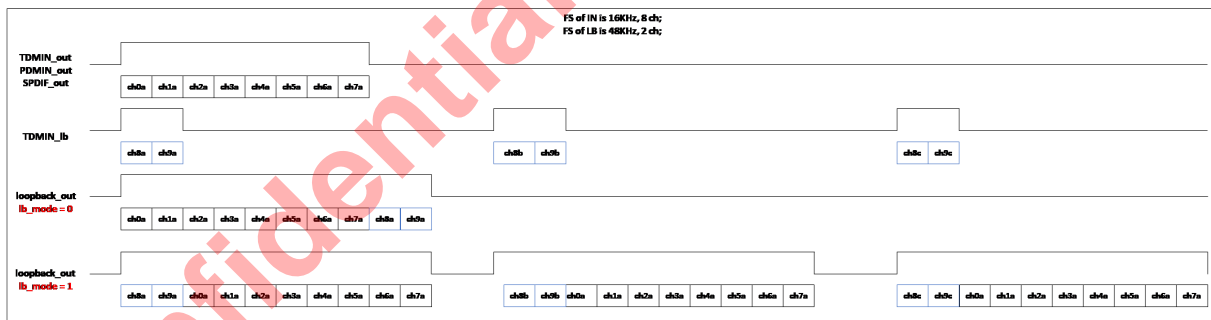

## 10.6 Audio ResampleA

Audio resampleA changes data from one symbol rate to another symbol rate in the following steps:

1. Max 8 audio sources is supported ,should be muxed to 1 source to audio\_resample core;
2. MSB/LSB selection is supported after source mux;
3. resample core do the symbol rate convert, max 8/32 channel is supported.;
  - a. If need down sample, aa filter should be on, max 64 tap is supported. 1/2 and 1/4 down sample is supported;
  - b. Audio re-sample use sinc filter, max 64tap, 1/2^28 phase precision interpolation;

- c. IIR compensation filter is used for compensate high-frequency damping;
- 4. Phase lock module is used for input-clock and output-clock symbol rate synchronization.

**Figure 10-13 Audio Resample**

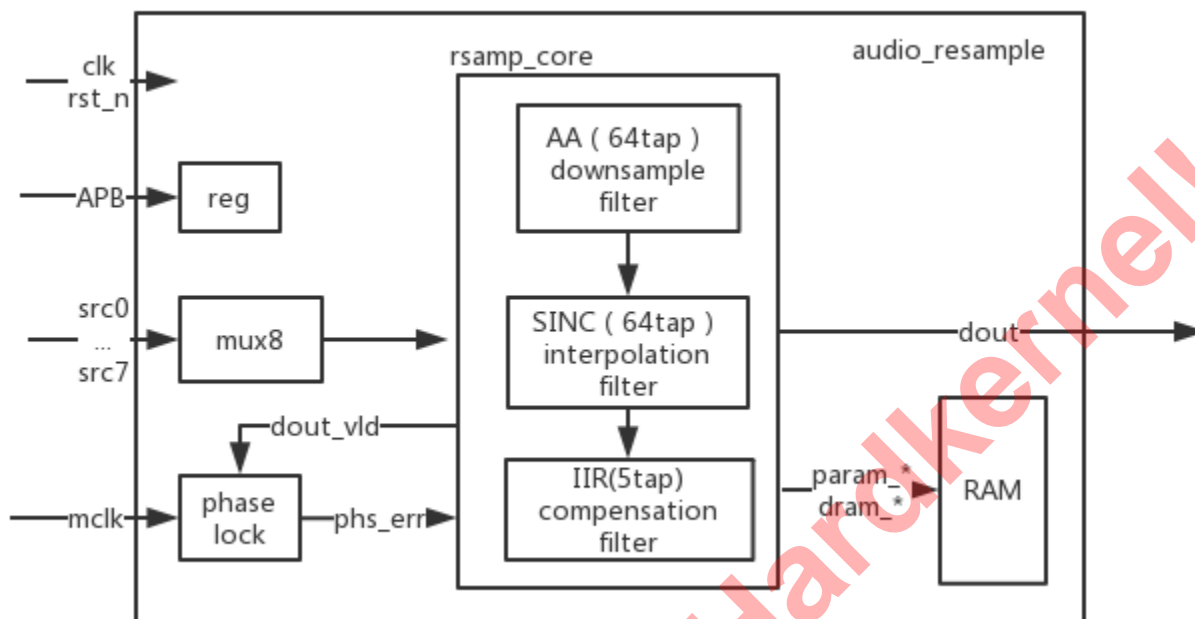

## 10.7 Audio ResampleB

Audio resampleB changes data from one symbol rate to another symbol rate in the following steps:

1. Input is from Toddr and selected by toddr's m/n register. Example A:  $toddr\_m = 27$ ,  $toddr\_n=4$ ,  $resample\_in[31:0] = \{8'd0, toddr\_in[27:4]\}$ ;
2. Cut or extend input from 32 bits to 16 bits. By example A, set  $resample\_M = 23$ , then  $filter\_in = toddr\_in[27:12]$ ;
3. Split to each channel (max is 8ch);
4. Interpolation by a cubic filter;
5. Use an IIR filter compensate;

Figure 10-14 Audio Resample

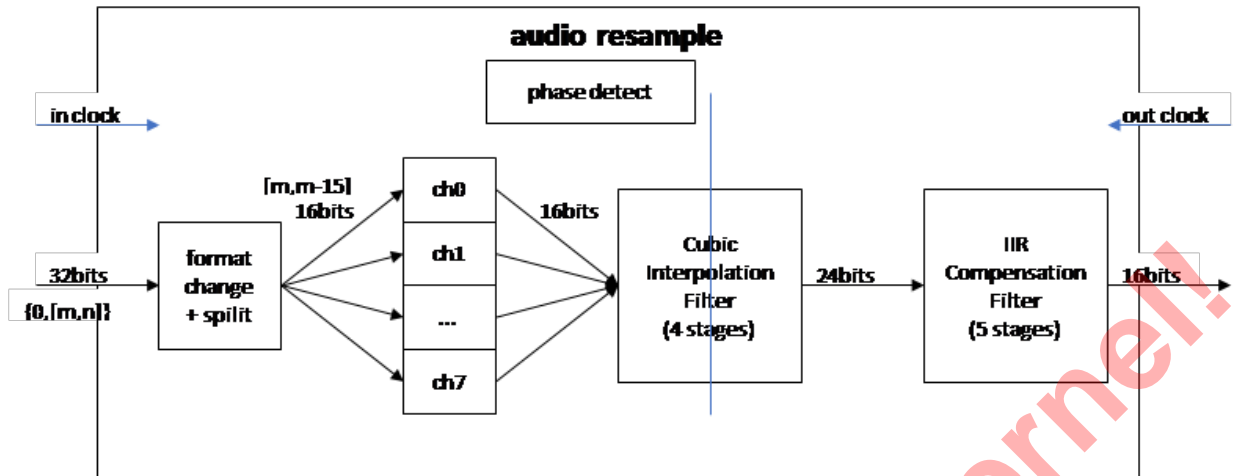

**Note**

In the diagram, the module phase\_det is used to calculate the interpolation phase, the module interp is used to implement the interpolation processing. There are two methods which can be implemented to calculate the interpolation phase. One is front feedback method, the other is accumulation method. They can be switched by register.

**(A) method 0**

The method 0 is the direct feedback method. According to the out\_valid, it interpolates the mapping sample. The operation flow is given below:

1. calculate the input data rate(average the count every input valid signal). For hdmi\_rx audio data, the input rate is basically even.

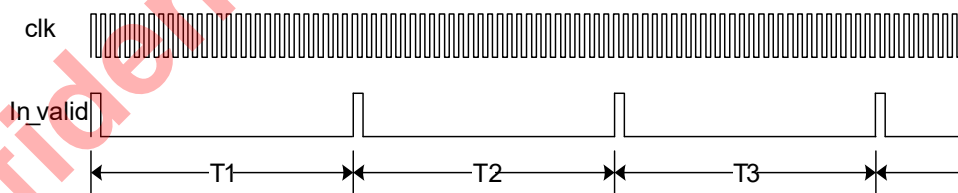

T02TM02

Count the clock number in T1, T2, and so on. get CNT then do average:

$$T = 0.999 * T + 0.001 * CNT$$

For 8 channels signal, the CNT should be count between 8 in\_valid signal.

2. In the output clock domain, generate the output valid signal. Because the output clock should be integral times of output frequency, the valid signal can easily generated by counting the output clock. Then change the valid signal to main clock domain.
3. Calculate the interpolation phase mu.



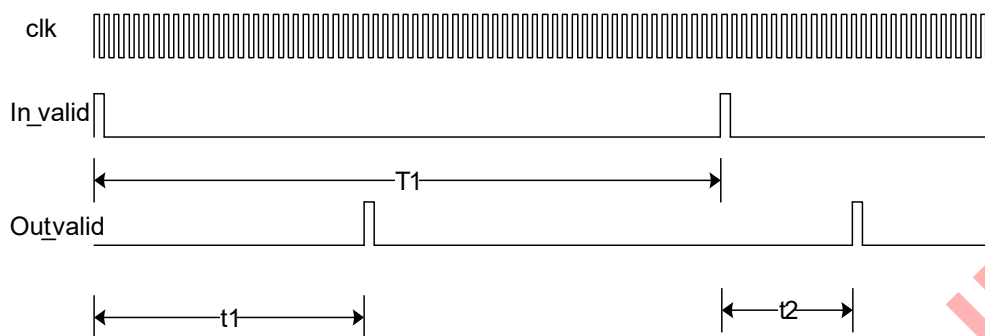

T02TM03

Count the clock number in t1 get cnt, then mu can be calculated:

$$\text{Mu} = \text{cnt}/T$$

The bit width of mu is 9 bits.

#### 4. Do the interpolation (4 points cubic interpolation)

Basic function is:

$$Y = ((a * \mu + b) * \mu + c) * \mu + d, \mu \text{ means interpolation phase.}$$

and

$$a = 16 * x_0 - 48 * x_1 + 48 * x_2 - 16 * x_3$$

$$b = 31 * x_0 - 31 * x_1 - 31 * x_2 + 31 * x_3$$

$$c = 23 * x_0 + 59 * x_1 - 59 * x_2 - 23 * x_3$$

$$d = 6 * x_0 + 58 * x_1 + 58 * x_2 + 6 * x_3$$

(x0, x1, x2 and x3 are the delay line of input data.)

#### Performance Analysis

The advantage of this method is that the output data rate is generated by output clock and match the acquirement of software absolutely.

The disadvantage is that the interpolation phase has bias. The bias relies on the main clock. More higher the main clock frequency is, more precise the interpolation result is.

Actually the precision of interpolation phase is 9 bits, so the frequency of main clock should be more than 512 times of input data rate.

#### (A) method 1

The method 1 is accumulation method. It assume the output frequency is accurate and stable. It sets a fixed phase step. The phase step is the ratio of the input frequency to output frequency. Every step, It outputs a sample. About the bias of input frequency, there is a register to report the statistics value. It can be used to adjust the initial phase step by firmware.

#### Performance Analysis

This method requires the audio output frequency precision, because there is no information statistics of output frequency. When the audio output frequency is not stable, it is recommended it not be used.

## 10.8 Audio VAD

VAD will wake up CPU when it determine if voice is present in a particular audio signal. It support 2 channels audio streams searching which combined from PDM filter output audio stream. The audio stream will be down-sampled to 8K/s rate and de-noised before detection processing. VAD can provide power detection, cepstral detection and spectral entropy detection. It will do the detection per 10ms. It contains one 256p FFT function for cepstral and spectral entropy calculation.

Figure 10-15 Audio VAD

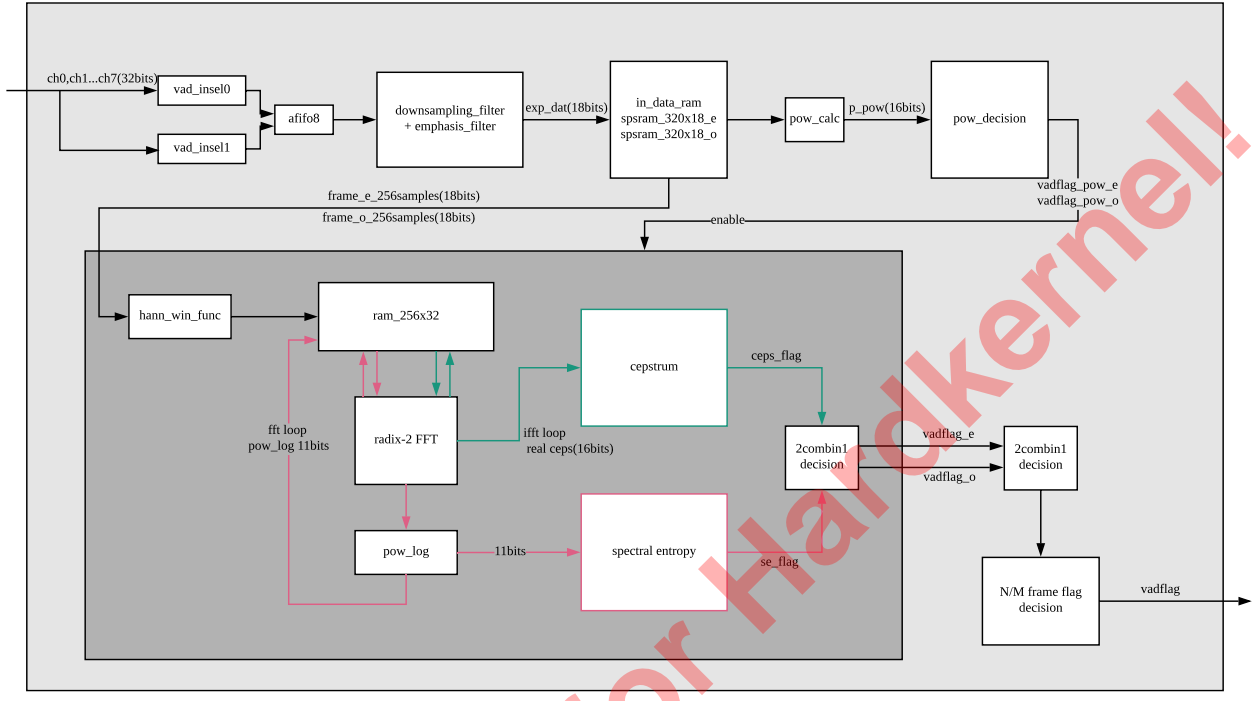

T02FC24

### 10.9 Audio EQDRC

It support 4 channels audio streams. Two channels do eq and drc, the others only do eq.

The basic structure diagram is shown below.

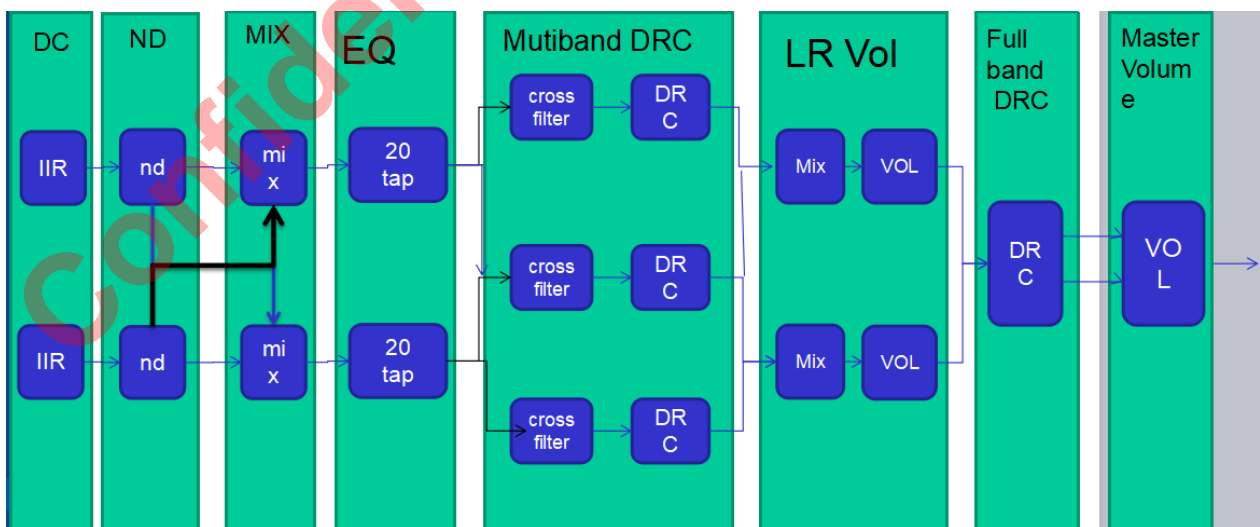

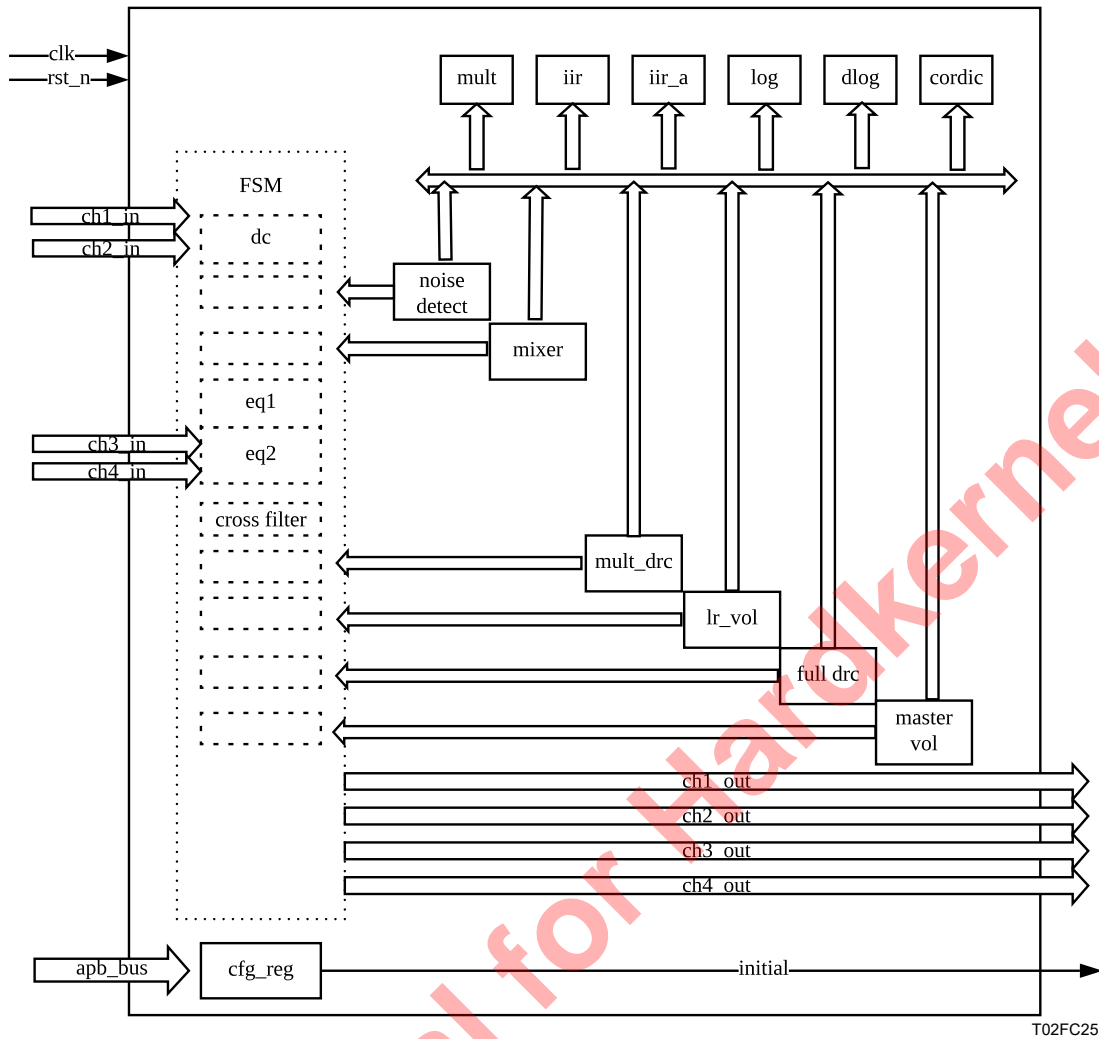

### 10.10 Audio Locker

The audio input clock and output clock are in different power domain and may have little difference, the difference leads to FIFO problem, the SoC uses Audio Locker module to fix this problem, the basic method is to measure the difference between different clocks and adjust (software dynamically) the clock frequency to make them match.

The diagram of Audio Locker module is shown below.

Figure 10-16 Audio Locker

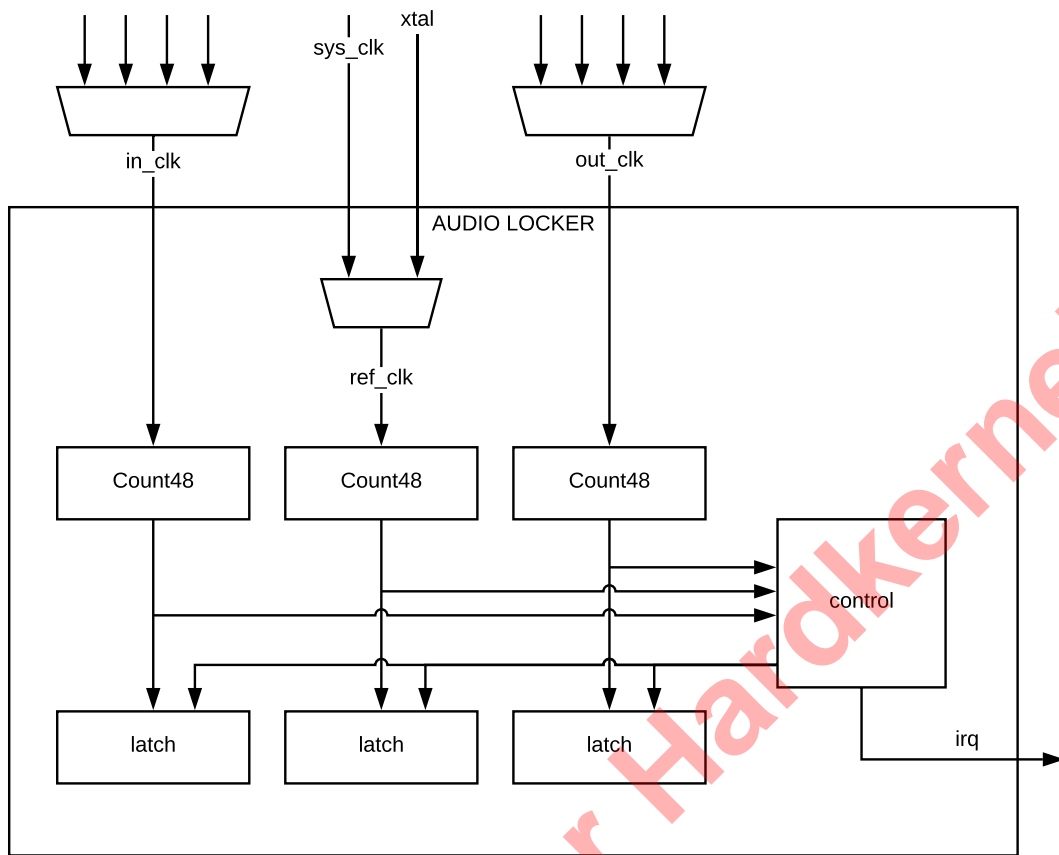

T02FC26

For example: when the diff of two freq creater than threshold is detected, change frequency of clock\_out by SW, will keep clock\_out close clock\_in.

Figure 10-17 Audio Locker Example

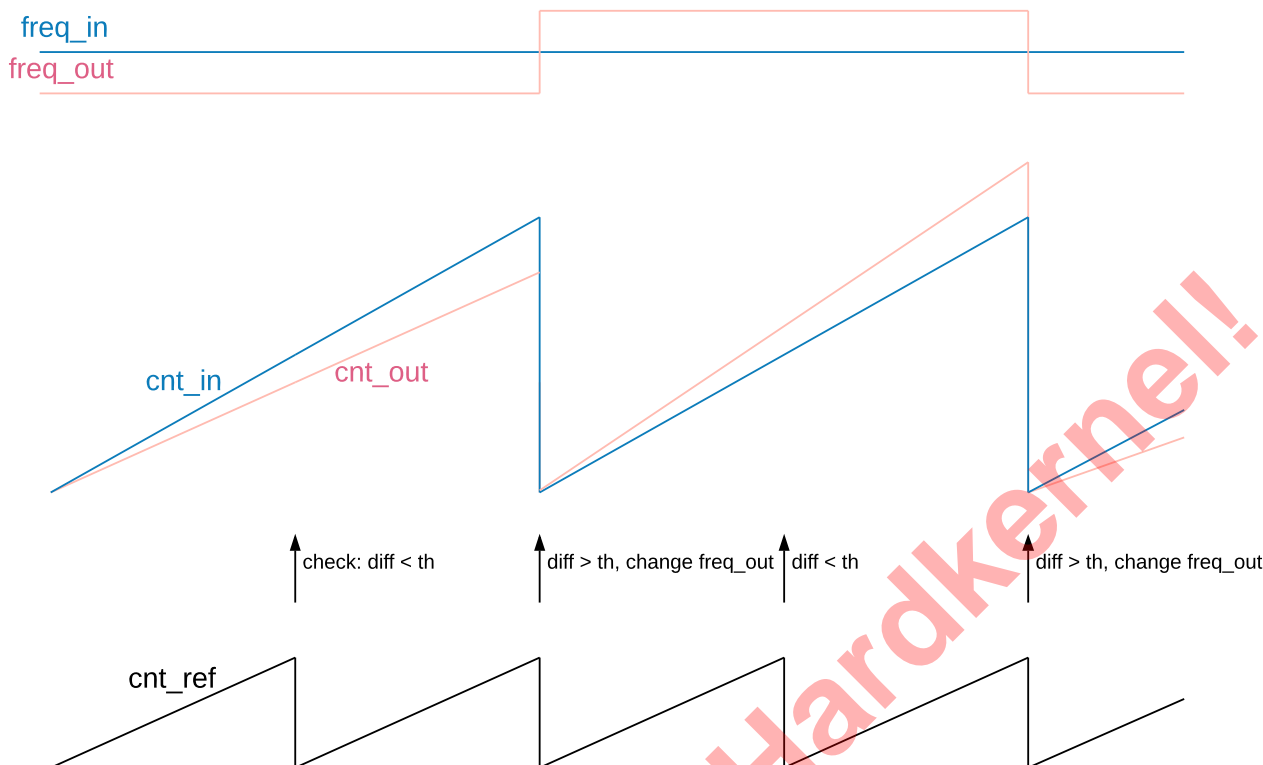

T02FC27

## 10.11 Register Description

For Below registers:

Base address: 0xFF660000

Each register final address = module base address+ address \* 4

### 10.11.1 CLK/RESET Registers

Table 10-1 EE\_AUDIO\_CLK\_GATE\_EN0 0x00

Bits	R/W	Default	Description
31	R/W	0x0000-0000	reserved
30	R/W		Reserved
29	R/W		Spdifin_lb, 0:disable; 1: enable;
28	R/W		Audio locker, 0:disable; 1: enable;
27	R/W		tovad, 0:disable; 1: enable;
26	R/W		resampleB, 0:disable; 1: enable;
25	R/W		reserved
24	R/W		reserved
23	R/W		reserved

Bits	R/W	Default	Description
22	R/W		eqdrc, 0:disable; 1: enable;
21	R/W		spdifoutB, 0:disable; 1: enable;
20	R/W		toram, 0:disable; 1: enable;
18	R/W		resampleA, 0:disable; 1: enable;
17	R/W		spdifout, 0:disable; 1: enable;
16	R/W		spdifin, 0:disable; 1: enable;
15	R/W		loopbackA, 0:disable; 1: enable;
14	R/W		toddrc, 0:disable; 1: enable;
13	R/W		toddrb, 0:disable; 1: enable;
12	R/W		toddra, 0:disable; 1: enable;
11	R/W		frddrc, 0:disable; 1: enable;
10	R/W		frddrb, 0:disable; 1: enable;
9	R/W		frddra, 0:disable; 1: enable;
8	R/W		tdmoutc, 0:disable; 1: enable;
7	R/W		tdmoutb, 0:disable; 1: enable;
6	R/W		tmdouta, 0:disable; 1: enable;
5	R/W		tdminlb, 0:disable; 1: enable;
4	R/W		tdminc, 0:disable; 1: enable;
3	R/W		tdminb, 0:disable; 1: enable;
2	R/W		tdmina, 0:disable; 1: enable;
1	R/W		pdm, 0:disable; 1: enable;
0	R/W		ddr_arb, 0:disable; 1: enable;

Table 10-2 EE\_AUDIO\_CLK\_GATE\_EN1 0x01

Bits	R/W	Default	Description
31:3	R/W	0x00000000	reserved
6	R/W		
5	R/W		
4	R/W		
3	R/W		
2	R/W		loopbackB, 0:disable; 1: enable;
1	R/W		toddrd, 0:disable; 1: enable;
0	R/W		frddrd, 0:disable; 1: enable;

**Table 10-3 EE\_AUDIO\_MCLK\_A\_CTRL 0x02**

Bits	R/W	Default	Description
31	R/W	0x0000-0000	clk_en, 0:disable; 1: enable;
30	R/W		Force_oscin, 0:disable; 1: force clock source as oscin(24M);
26:24	R/W		clk_sel, 0:mp0_pll; 1:mp1_pll; 2:mp2_pll; 3:mp3_pll; 4:hifi_pll; 5:fclk_div3(666M); 6:fclk_div4(500M); 7:fclk_div5(400M);
15:0	R/W		clk_div, the frequency of mclk = pll/clk_div;

EE\_AUDIO\_MCLK\_B\_CTRL 0x03

Same as EE\_AUDIO\_MCLK\_A\_CTRL.

EE\_AUDIO\_MCLK\_C\_CTRL 0x04

Same as EE\_AUDIO\_MCLK\_A\_CTRL.

EE\_AUDIO\_MCLK\_D\_CTRL 0x05

Same as EE\_AUDIO\_MCLK\_A\_CTRL.

EE\_AUDIO\_MCLK\_E\_CTRL 0x06

Same as EE\_AUDIO\_MCLK\_A\_CTRL.

EE\_AUDIO\_MCLK\_F\_CTRL 0x07

Same as EE\_AUDIO\_MCLK\_A\_CTRL.

**Table 10-4 EE\_AUDIO\_MST\_PAD\_CTRL0 0x08**

Bits	R/W	Default	Description
31	R/W	0	mclk_pad_1_en;
30	R/W	0	mclk_pad_1, force to xtal;
29	R/W	0	mclk_pad_1_ctrl_sel;
26:24	R/W	0	mclk_pad_1_sel: 0: mclk_a; 1: mclk_b; 2: mclk_c; 3: mclk_d; 4: mclk_e; 5: mclk_f;
23:16	R/W	0	Mclk_pad_1_div: the mclk_pad will div by mclk source;
15	R/W	0	mclk_pad_0_en
14	R/W	0	mclk_pad_0, force to xtal;
13	R/W	0	mclk_pad_0_ctrl_sel;

Bits	R/W	Default	Description
10:8	R/W	0	mclk_pad_0_sel: 0: mclk_a; 1: mclk_b; 2: mclk_c; 3: mclk_d; 4: mclk_e; 5: mclk_f;
7:0	R/W	0	Mclk_pad_0_div: the mclk_pad will div by mclk source;

Table 10-5 EE\_AUDIO\_MST\_PAD\_CTRL1 0x09

Bits	R/W	Default	Description
26:24	R/W	0	lrclk_pad_2_sel: 0: lrclk_a; 1: lrclk_b; 2: lrclk_c; 3: lrclk_d; 4: lrclk_e; 5: lrclk_f;
22:20	R/W	0	lrclk_pad_1_sel: 0: lrclk_a; 1: lrclk_b; 2: lrclk_c; 3: lrclk_d; 4: lrclk_e; 5: lrclk_f;
18:16	R/W	0	lrclk_pad_0_sel: 0: lrclk_a; 1: lrclk_b; 2: lrclk_c; 3: lrclk_d; 4: lrclk_e; 5: lrclk_f;
10:8	R/W	0	sclk_pad_2_sel: 0: sclk_a; 1: sclk_b; 2: sclk_c; 3: sclk_d; 4: sclk_e; 5: sclk_f;
6:4	R/W	0	sclk_pad_1_sel: 0: sclk_a; 1: sclk_b; 2: sclk_c; 3: sclk_d; 4: sclk_e; 5: sclk_f;
2:0	R/W	0	sclk_pad_0_sel: 0: sclk_a; 1: sclk_b; 2: sclk_c; 3: sclk_d; 4: sclk_e; 5: sclk_f;



Table 10-6 EE\_AUDIO\_SW\_RESET0 0x0A

Bits	R/W	Default	Description
31	R/W	0	Frhdmirx
30	R/W	0	Fratv
29	R/W	0	Spdifin_lb
28	R/W	0	Locker
27	R/W	0	Tovad
26	R/W	0	resampleB
25	R/W	0	clk tree
24	R/W	0	tohdmitx
23	R/W	0	toacodec
22	R/W	0	toram
21	R/W	0	powdet
20	R/W	0	ddrab
19	R/W	0	resample
18	R/W	0	eqdrc
17	R/W	0	spdifin
16	R/W	0	spdifoutB
15	R/W	0	spdifout
14	R/W	0	tdmoutc
13	R/W	0	tdmoutb
12	R/W	0	tdmouta
11	R/W	0	frddrc
10	R/W	0	frddrb
9	R/W	0	frddra
8	R/W	0	toddrb
7	R/W	0	toddra
6	R/W	0	loopback
5	R/W	0	tdmin_lb
4	R/W	0	tdminc
3	R/W	0	tdminb
2	R/W	0	tdmina
1	R/W	0	pdm
0	R/W	0	

**Table 10-7 EE\_AUDIO\_SW\_RESET1 0x0B**

Bits	R/W	Default	Description
6	R/W	0	toddre
5	R/W	0	frddre
4	R/W	0	earcrx
3	R/W	0	earctx
2	R/W	0	loopbackB
1	R/W	0	toddrd
0	R/W	0	frddrd

**Table 10-8 EE\_AUDIO\_CLK81\_CTRL 0x0C**

Bits	R/W	Default	Description
31	R	0	Select out
24	R/W	0	Sys_clk_B enable
23:16	R/W	0	Sys_clk_B div
15	R/W	0	0: Select sys_clk_A; 1: Select sys_clk_B;
8	R/W	0	Sys_clk_A enable
7:0	R/W	0	Sys_clk_A div

**Figure 10-18 EE\_AUDIO\_CLK81\_CTRL**

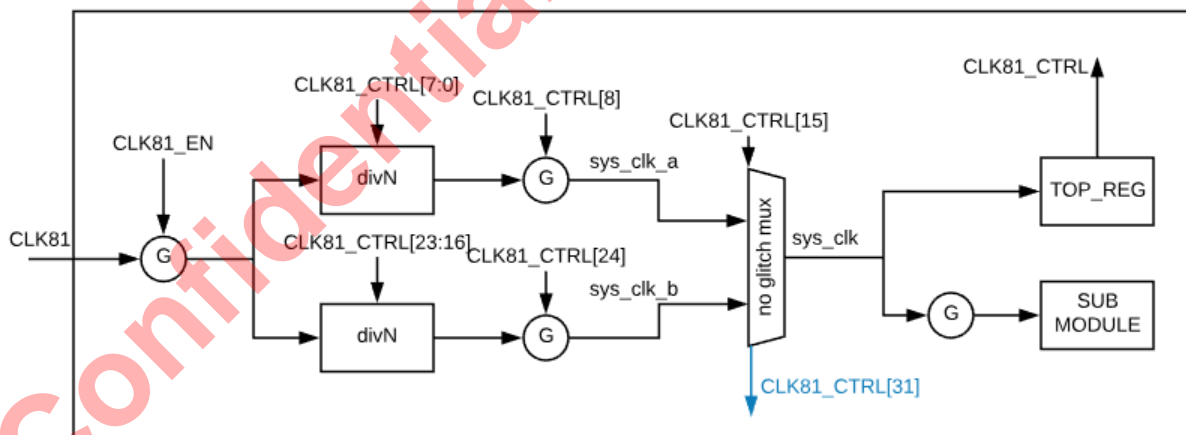

**Table 10-9 EE\_AUDIO\_CLK81\_EN 0x0D**

Bits	W	Default	Description
31	R/W	0	Write 0 will off all clk81(sys_clk) in audio top. And will make error if access to all audio register if EN = 0.

**Table 10-10 EE\_AUDIO\_MST\_A\_SCLK\_CTRL0 0x10**

Bits	R/W	Default	Description
31	R/W	0x0000-0000	clk_in_en, 0:disable; 1: enable;
30	R/W		clk_out_en, 0:disable; 1: enable;
29:20	R/W		sclk_div, the frequency of sclk = mclk/sclk_div;
19:10	R/W		lrclk_hi, duty cycle of LRCLK, less than lrclk_div; example 0: lrclk_hi = 1, LRCLK will only keep one cycle; example 1: lrclk_hi = lrclk_div/2, LRCLK will be 50/50 duty cycle;
9:0	R/W		lrclk_div, the frequency of lrclk = sclk/lrclk_div;

**Table 10-11 EE\_AUDIO\_MST\_A\_SCLK\_CTRL1 0x11**

Bits	R/W	Default	Description
31:28	R/W	0x0000-0000	sclk_ph0_sel, select from sclk_delay_line(depth is 16)
27:24	R/W		lrclk_ph0_sel, select from lrclk_delay_line(depth is 16)
23:20	R/W		sclk_ph1_sel, select from sclk_delay_line(depth is 16)
19:16	R/W		lrclk_ph1_sel, select from lrclk_delay_line(depth is 16)
15:12	R/W		sclk_ph2_sel, select from sclk_delay_line(depth is 16)
11:8	R/W		lrclk_ph2_sel, select from lrclk_delay_line(depth is 16)
5:0	R/W		clk_inv, invert clk; [5]: lrclk_ph2; [4]: sclk_ph2; [3]: lrclk_ph1; [2]: sclk_ph1; [1]: lrclk_ph0; [0]: sclk_ph0;

**Figure 10-19 LRCLK Setting**

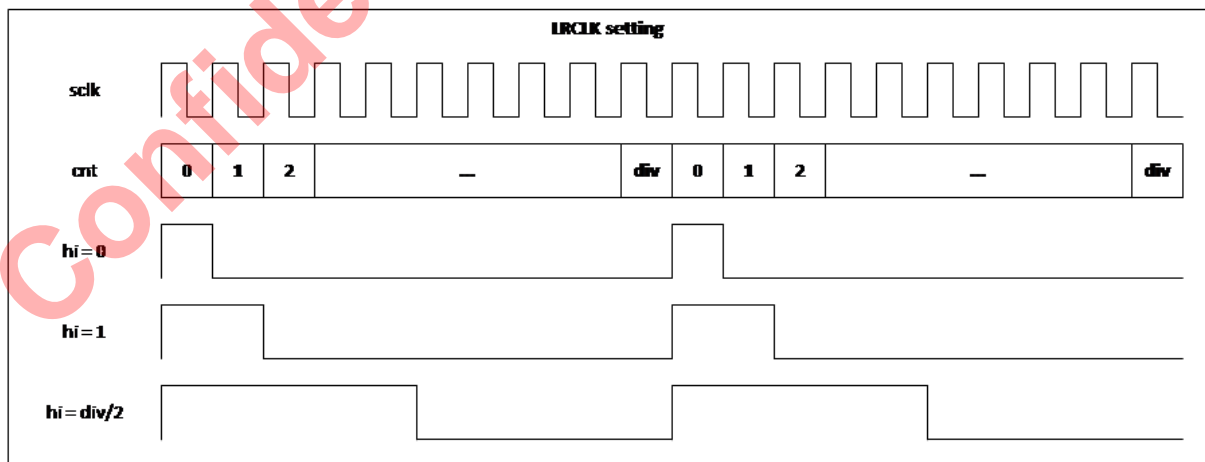

EE\_AUDIO\_MST\_B\_SCLK\_CTRL0 0x12

Same as EE\_AUDIO\_MST\_A\_SCLK\_CTRL0  
 EE\_AUDIO\_MST\_B\_SCLK\_CTRL1 0x13  
 Same as EE\_AUDIO\_MST\_A\_SCLK\_CTRL1  
 EE\_AUDIO\_MST\_C\_SCLK\_CTRL0 0x14  
 Same as EE\_AUDIO\_MST\_A\_SCLK\_CTRL0  
 EE\_AUDIO\_MST\_C\_SCLK\_CTRL1 0x15  
 Same as EE\_AUDIO\_MST\_A\_SCLK\_CTRL1  
 EE\_AUDIO\_MST\_D\_SCLK\_CTRL0 0x16  
 Same as EE\_AUDIO\_MST\_A\_SCLK\_CTRL0  
 EE\_AUDIO\_MST\_D\_SCLK\_CTRL1 0x17  
 Same as EE\_AUDIO\_MST\_A\_SCLK\_CTRL1  
 EE\_AUDIO\_MST\_E\_SCLK\_CTRL0 0x18  
 Same as EE\_AUDIO\_MST\_A\_SCLK\_CTRL0  
 EE\_AUDIO\_MST\_E\_SCLK\_CTRL1 0x19  
 Same as EE\_AUDIO\_MST\_A\_SCLK\_CTRL1  
 EE\_AUDIO\_MST\_F\_SCLK\_CTRL0 0x1a  
 Same as EE\_AUDIO\_MST\_A\_SCLK\_CTRL0  
 EE\_AUDIO\_MST\_F\_SCLK\_CTRL1 0x1b  
 Same as EE\_AUDIO\_MST\_A\_SCLK\_CTRL1

**Table 10-12 EE\_AUDIO\_MST\_DLY\_CTRL0 0x1c**

Bits	R/W	Default	Description
31:24	R/W	0x00000000	reserved
23:20	R/W		mst_sclk_f_ph1_dly_sel;
19:16	R/W		mst_sclk_e_ph1_dly_sel;
15:12	R/W		mst_sclk_d_ph1_dly_sel;
11:8	R/W		mst_sclk_c_ph1_dly_sel;
7:4	R/W		mst_sclk_b_ph1_dly_sel;
3:0	R/W		mst_sclk_a_ph1_dly_sel;

**Table 10-13 EE\_AUDIO\_MST\_DLY\_CTRL1 0x1d**

Bits	R/W	Default	Description
31:24	R/W	0x00000000	reserved
23:20	R/W		mst_lrcclk_f_ph1_dly_sel;
19:16	R/W		mst_lrcclk_e_ph1_dly_sel;
15:12	R/W		mst_lrcclk_d_ph1_dly_sel;
11:8	R/W		mst_lrcclk_c_ph1_dly_sel;

Bits	R/W	Default	Description
7:4	R/W		mst_lrclk_b_ph1_dly_sel;
3:0	R/W		mst_lrclk_a_ph1_dly_sel;

Table 10-14 EE\_AUDIO\_CLK\_TDMIN\_A\_CTRL 0x20

Bits	R/W	Default	Description
31	R/W	0x0000-0000	clk_in_en, 0:disable; 1: enable;
30	R/W		clk_out_en, 0:disable; 1: enable;
29	R/W		sclk_inv, 0:not revert; 1: revert clock;
27:24	R/W		sclk_sel, 0:mst_a_sclk_ph1; 1:mst_b_sclk_ph1; 2:mst_c_sclk_ph1; 3:mst_d_sclk_ph1; 4:mst_e_sclk_ph1; 5:mst_f_sclk_ph1; 6:i_slv_sclk_a 7:i_slv_sclk_b 8:i_slv_sclk_c 9:i_slv_sclk_d ; 10:i_slv_sclk_e ; 11:i_slv_sclk_f ; 12:i_slv_sclk_g ; 13:i_slv_sclk_h ; 14:i_slv_sclk_i ; 15:i_slv_sclk_j ;
23:20	R/W		lrclk_sel, 0:mst_a_lrclk_ph1; 1:mst_b_lrclk_ph1; 2:mst_c_lrclk_ph1; 3:mst_d_lrclk_ph1; 4:mst_e_lrclk_ph1; 5:mst_f_lrclk_ph1; 6:i_slv_lrclk_a 7:i_slv_lrclk_b 8:i_slv_lrclk_c 9:i_slv_lrclk_d ; 10:i_slv_lrclk_e ; 11:i_slv_lrclk_f ; 12:i_slv_lrclk_g ; 13:i_slv_lrclk_h ; 14:i_slv_lrclk_i ; 15:i_slv_lrclk_j ;

EE\_AUDIO\_CLK\_TDMIN\_B\_CTRL 0x21

Same as EE\_AUDIO\_CLK\_TDMIN\_A\_CTRL

EE\_AUDIO\_CLK\_TDMIN\_C\_CTRL 0x22

Same as EE\_AUDIO\_CLK\_TDMIN\_A\_CTRL

EE\_AUDIO\_CLK\_TDMIN\_LB\_CTRL 0x23

Same as EE\_AUDIO\_CLK\_TDMIN\_A\_CTRL

Table 10-15 EE\_AUDIO\_CLK\_TDMOUT\_A\_CTRL 0x24

Bits	R/W	Default	Description
31	R/W	0x0000-0000	clk_in_en, 0:disable; 1: enable;
30	R/W		clk_out_en, 0:disable; 1: enable;
29	R/W		sclk_inv, 0:not revert; 1: revert clock;
28	R/W		Sclk_ws_inv, for the capture ws sclk; 0: not revert; 1: revert clock;

Bits	R/W	Default	Description
27:24	R/W		sclk_sel, 0:mst_a_sclk_ph1; 1:mst_b_sclk_ph1; 2:mst_c_sclk_ph1; 3:mst_d_sclk_ph1; 4:mst_e_sclk_ph1; 5:mst_f_sclk_ph1; 6:i_slv_sclk_a; 7:i_slv_sclk_b; 8:i_slv_sclk_c; 9:i_slv_sclk_d; 10:i_slv_sclk_e; 11:i_slv_sclk_f; 12:i_slv_sclk_g; 13:i_slv_sclk_h; 14:i_slv_sclk_i; 15:i_slv_sclk_j;
23:20	R/W		lrclk_sel, 0:mst_a_lrclk_ph1; 1:mst_b_lrclk_ph1; 2:mst_c_lrclk_ph1; 3:mst_d_lrclk_ph1; 4:mst_e_lrclk_ph1; 5:mst_f_lrclk_ph1; 6:i_slv_lrclk_a; 7:i_slv_lrclk_b; 8:i_slv_lrclk_c; 9:i_slv_lrclk_d; 10:i_slv_lrclk_e; 11:i_slv_lrclk_f; 12:i_slv_lrclk_g; 13:i_slv_lrclk_h; 14:i_slv_lrclk_i; 15:i_slv_lrclk_j;

EE\_AUDIO\_CLK\_TDMOUT\_B\_CTRL 0x25

Same as EE\_AUDIO\_CLK\_TDMOUT\_A\_CTRL

EE\_AUDIO\_CLK\_TDMOUT\_C\_CTRL 0x26

Same as EE\_AUDIO\_CLK\_TDMOUT\_A\_CTRL

**Table 10-16 EE\_AUDIO\_CLK\_SPDIFIN\_CTRL 0x27**

Bits	R/W	Default	Description
31	R/W	0x0000-0000	clk_en, 0:disable; 1: enable;
30	R/W		Force_oscin, 0:disable; 1: force clock source as oscin(24M);
26:24	R/W		clk_sel, 0:mp0_pll; 1:mp1_pll; 2:mp2_pll; 3:mp3_pll; 4:hifi_pll; 5:fclk_div3(666M); 6:fclk_div4(500M); 7:fclk_div5(400M);
7:0	R/W		clk_div, the frequency of mclk = pll/clk_div;

Table 10-17 EE\_AUDIO\_CLK\_SPDIFOUT\_CTRL 0x28

Bits	R/W	Default	Description
31	R/W	0x0000-0000	clk_en, 0:disable; 1: enable;
30	R/W		Force_oscin, 0:disable; 1: force clock source as oscin(24M);
26:24	R/W		clk_sel, 0:mp0_pll; 1:mp1_pll; 2:mp2_pll; 3:mp3_pll; 4:hifi_pll; 5:fclk_div3(666M); 6:fclk_div4(500M); 7:fclk_div5(400M);
9:0	R/W		clk_div, the frequency of mclk = pll/clk_div;

Table 10-18 EE\_AUDIO\_CLK\_RESAMPLEA\_CTRL 0x29

Bits	R/W	Default	Description
31	R/W	0x0000-0000	clk_en, 0:disable; 1: enable;
30	R/W		Force_oscin, 0:disable; 1: force clock source as oscin(24M);
27:24	R/W		sclk_sel, 0:mst_a_sclk_ph1; 1:mst_b_sclk_ph1; 2:mst_c_sclk_ph1; 3:mst_d_sclk_ph1; 4:mst_e_sclk_ph1; 5:mst_f_sclk_ph1; 6:i_slv_sclk_a ; 7:i_slv_sclk_b ; 8:i_slv_sclk_c ; 9:i_slv_sclk_d ; 10:i_slv_sclk_e ; 11:i_slv_sclk_f ; 12:i_slv_sclk_g ; 13:i_slv_sclk_h ; 14:i_slv_sclk_i ; 15:i_slv_sclk_j ;
7:0	R/W		Clk_div

Table 10-19 EE\_AUDIO\_CLK\_LOCKER\_CTRL 0x2a

Bits	R/W	Default	Description
31	R/W	0x0000-0000	lock_out_clk; 0:disable; 1:enable;
30	R/W		Force_oscin for lock_out_clk, 0:disable; 1: force clock source as oscin(24M);
27:24	R/W		sclk_sel, 0:mst_a_sclk_ph1; 1:mst_b_sclk_ph1; 2:mst_c_sclk_ph1; 3:mst_d_sclk_ph1; 4:mst_e_sclk_ph1; 5:mst_f_sclk_ph1; 6:i_slv_sclk_a ; 7:i_slv_sclk_b ; 8:i_slv_sclk_c ; 9:i_slv_sclk_d ;

Bits	R/W	Default	Description
			10:i_slv_sclk_e; 11:i_slv_sclk_f; 12:i_slv_sclk_g; 13:i_slv_sclk_h; 15:spdifin_find_z;
23:16	R/W		clk_div, lock_out_clk; out = in/clk_div;
15	R/W		clk_en, lock_in_clk; 0:disable; 1:enable;
14	R/W		Force_oscin for lock_in_clk, 0:disable; 1: force clock source as oscin(24M);
11:8	R/W		clk_sel, lock_in_clk; 0:mst_a_mclk; 1:mst_b_mclk; 2:mst_c_mclk; 3:mst_d_mclk; 4:mst_e_mclk; 5:mst_f_mclk; 6:i_slv_sclk_a; 7:i_slv_sclk_b; 8:i_slv_sclk_c; 9:i_slv_sclk_d; 10:i_slv_sclk_e; 11:i_slv_sclk_f; 12:i_slv_sclk_g; 13:i_slv_sclk_h; 15:spdifin_find_z;
7:0	R/W		clk_div, lock_in_clk; out = in/clk_div;

Table 10-20 EE\_AUDIO\_CLK\_PDMIN\_CTRL0 0x2b

Bits	R/W	Default	Description
31	R/W	0x0000-0000	clk_en, 0:disable; 1: enable;
30	R/W		Force_oscin, 0:disable; 1: force clock source as oscin(24M);
26:24	R/W		clk_sel, 0:mp0_pll; 1:mp1_pll; 2:mp2_pll; 3:mp3_pll; 4:hifi_pll; 5:fclk_div3(666M); 6:fclk_div4(500M); 7:fclk_div5(400M);
15:0	R/W		the frequency of pdm_dclk = pll/clk_div;

Table 10-21 EE\_AUDIO\_CLK\_PDMIN\_CTRL1 0x2c

Bits	R/W	Default	Description
31	R/W	0x0000-0000	clk_en, 0:disable; 1: enable;
30	R/W		Force_oscin, 0:disable; 1: force clock source as oscin(24M);



Bits	R/W	Default	Description
26:24	R/W		clk_sel, 0:mp0_pll; 1:mp1_pll; 2:mp2_pll; 3:mp3_pll; 4:hifi_pll; 5:fclk_div3(666M); 6:fclk_div4(500M); 7:fclk_div5(400M);
15:0	R/W		the frequency of pdm_sysclk = pll/clk_div;

Table 10-22 EE\_AUDIO\_CLK\_SPDIFOUT\_B\_CTRL 0x2d

Bits	R/W	Default	Description
31	R/W	0x0000-0000	clk_en, 0:disable; 1: enable;
30	R/W		Force_oscin, 0:disable; 1: force clock source as oscin(24M);
26:24	R/W		clk_sel, 0:mp0_pll; 1:mp1_pll; 2:mp2_pll; 3:mp3_pll; 4:hifi_pll; 5:fclk_div3(666M); 6:fclk_div4(500M); 7:fclk_div5(400M);
9:0	R/W		clk_div, the frequency of mclk = pll/clk_div;

Table 10-23 EE\_AUDIO\_CLK\_RESAMPLEB\_CTRL 0x2E

Bits	R/W	Default	Description
31	R/W	0x0000-0000	clk_en, 0:disable; 1: enable;
30	R/W		Force_oscin, 0:disable; 1: force clock source as oscin(24M);
27:24	R/W		sclk_sel, 0:mst_a_sclk_ph1; 1:mst_b_sclk_ph1; 2:mst_c_sclk_ph1; 3:mst_d_sclk_ph1; 4:mst_e_sclk_ph1; 5:mst_f_sclk_ph1; 6:i_slv_sclk_a; 7:i_slv_sclk_b; 8:i_slv_sclk_c; 9:i_slv_sclk_d; 10:i_slv_sclk_e; 11:i_slv_sclk_f; 12:i_slv_sclk_g; 13:i_slv_sclk_h; 14:i_slv_sclk_i; 15:i_slv_sclk_j;
7:0	R/W		Clk_div

Table 10-24 EE\_AUDIO\_CLK\_SPDIFIN\_LB\_CTRL 0x2F

Bits	R/W	Default	Description
31	R/W	0x0000-0000	clk_en, 0:disable; 1: enable;
30	R/W		Clk_sel: 0: spdif_out_a clk; 1: spdif_out_b clk;
29	R/W		Clk_inv

Table 10-25 EE\_AUDIO\_CLK\_EQDRC\_CTRL 0x30

Bits	R/W	Default	Description
31	R/W	0x0000-0000	clk_en, 0:disable; 1: enable;
30	R/W		Force_oscin, 0:disable; 1: force clock source as oscin(24M);
26:24	R/W		0:mp0_pll; 1:mp1_pll; 2:mp2_pll; 3:mp3_pll; 4:hifi_pll; 5:fclk_div3(666M); 6:fclk_div4(500M); 7:fclk_div5(400M)
15:0	R/W		Clk_div

Table 10-26 EE\_AUDIO\_CLK\_VAD\_CTRL 0x31

Bits	R/W	Default	Description
31	R/W	0x0000-0000	clk_en, 0:disable; 1: enable;
30	R/W		Force_oscin, 0:disable; 1: force clock source as oscin(24M);
26:24	R/W		0:mp0_pll; 1:mp1_pll; 2:mp2_pll; 3:mp3_pll; 4:hifi_pll; 5:fclk_div3(666M); 6:fclk_div4(500M); 7:fclk_div5(400M)
15:0	R/W		Clk_div

### 10.11.2 TODDR Registers

Table 10-27 EE\_AUDIO\_TODDR\_A\_CTRL0 0x40

Bits	R/W	Default	Description
31	R/W	0x0000-0000	reg_toddr_en, 0: disable; 1: enable;
29	R/W		reg_ext_signed, 0: select write to only one buff (start_addr,finish_addr); 1: select write to two buff (start_addr,finish_addr) (start_addrb, finish_addrb);

Bits	R/W	Default	Description
28	R/W		reg_toddr_endian
27	R/W		Enable_sync_chnum; 1: start store data when first ch ;
26:24	R/W		reg_toddr_int_en
23:16	R/W		[23] : reserved; [22] : reserved; [21] : fifo overflow, write when fifocnt = depth; [20] : fifo overflow, read when fifocnt = 0; [19] : when write to ddr "int_addr" data (only once); [18] : when write to ddr "int_addr" data (repeat); [17] : when write to ddr address match "int_addr"; [16] : when write to ddr address match "finish_addr";
15:13	R/W		reg_toddr_sel, 0: combined data[m:n] without gap; like S0[m:n],S1[m:n],S2[m:n], ... 1: combined data[m:n] as 16bits; like {S0[11:0],4'd0},{S1[11:0],4'd0}... 2: combined data[m:n] as 16bits; like {4'd0,S0[11:0]},{4'd0,{S1[11:0]}... 3: combined data[m:n] as 32bits; like {S0[27:4],8'd0},{S1[27:4],8'd0}... 4: combined data[m:n] as 32bits; like {8'd0,S0[27:4]},{8'd0,{S1[27:4]}...
12:8	R/W		reg_toddr_m_sel, the msb position in data
7:3	R/W		reg_toddr_n_sel, the lsb position in data
2	R/W		Clear adr/cnt value which captured by vad frame sync
1	R/W		Clear adr/cnt value which captured by vadflag
0	R/W		Ddr bus ugt bit

We can change format before write to DDR: TODDR-format

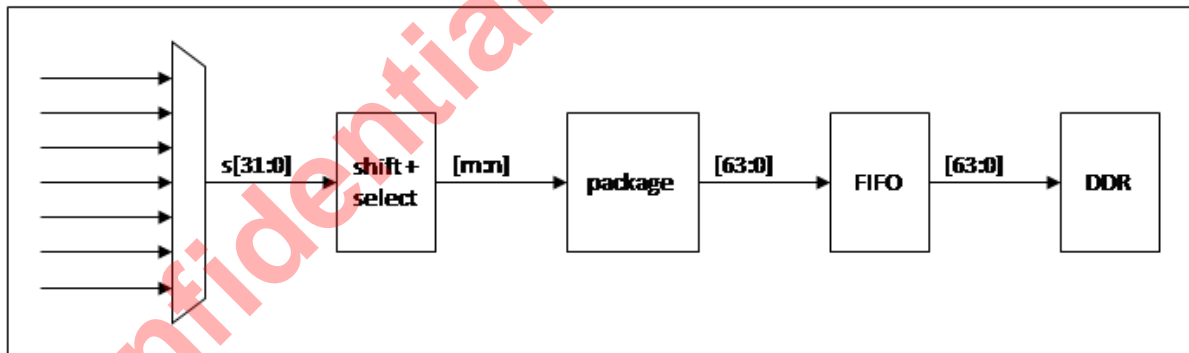

For example:

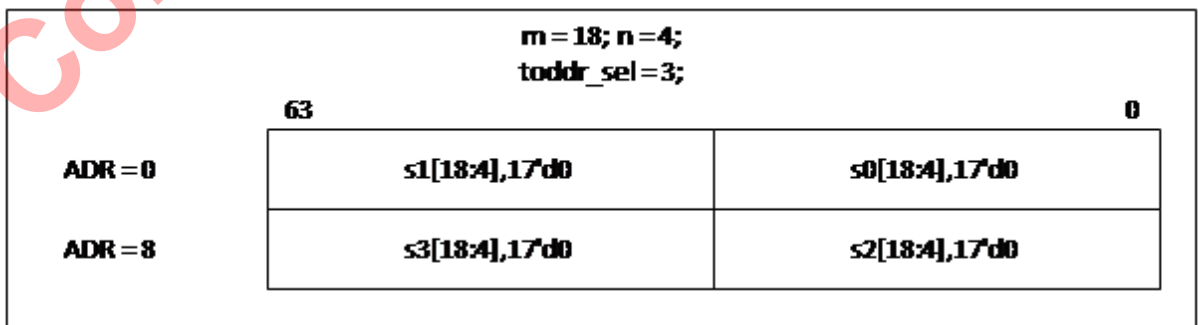
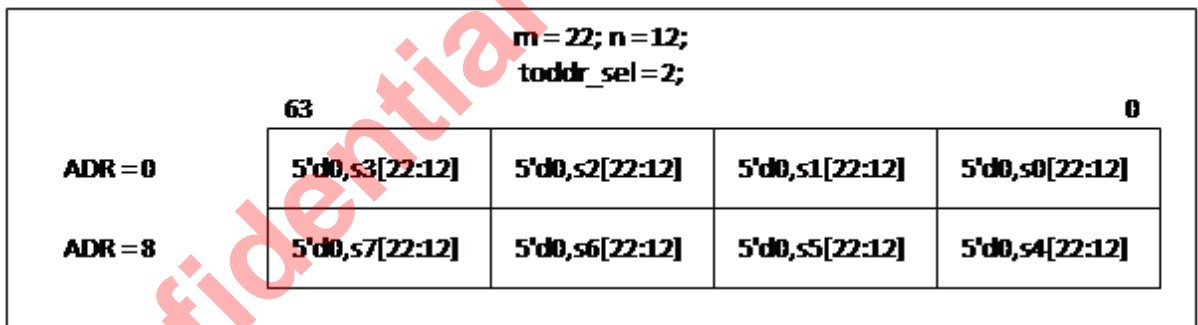
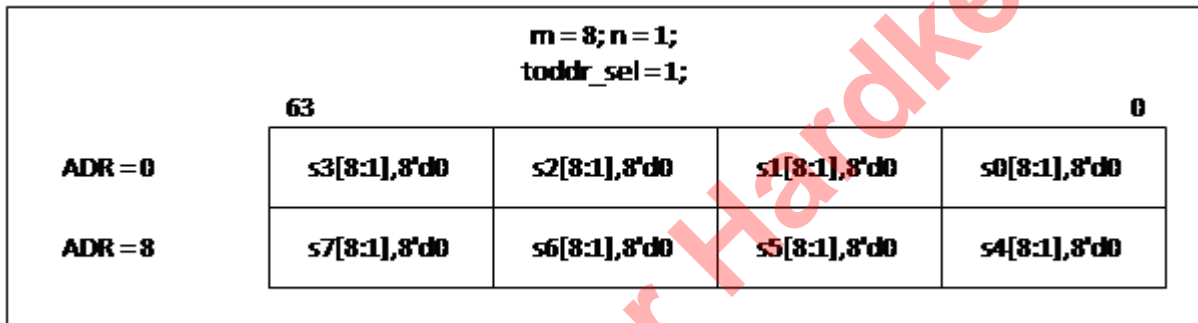
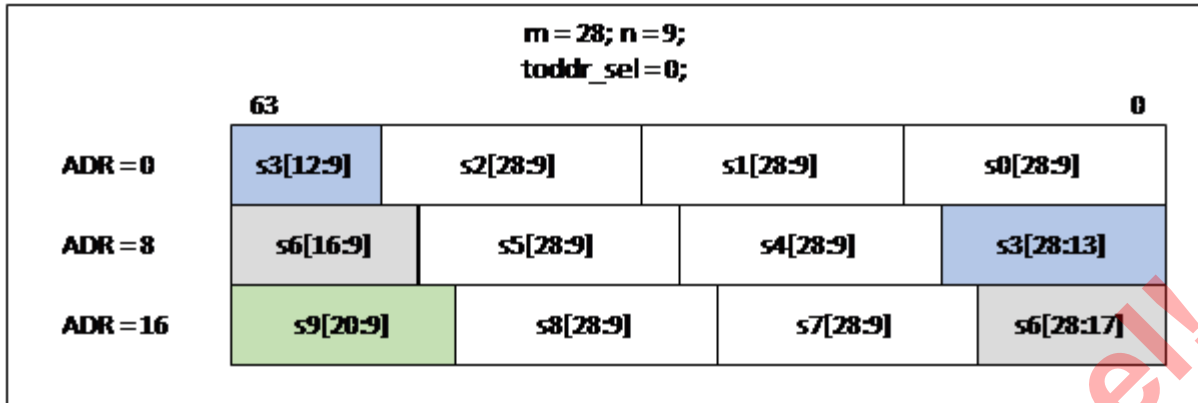

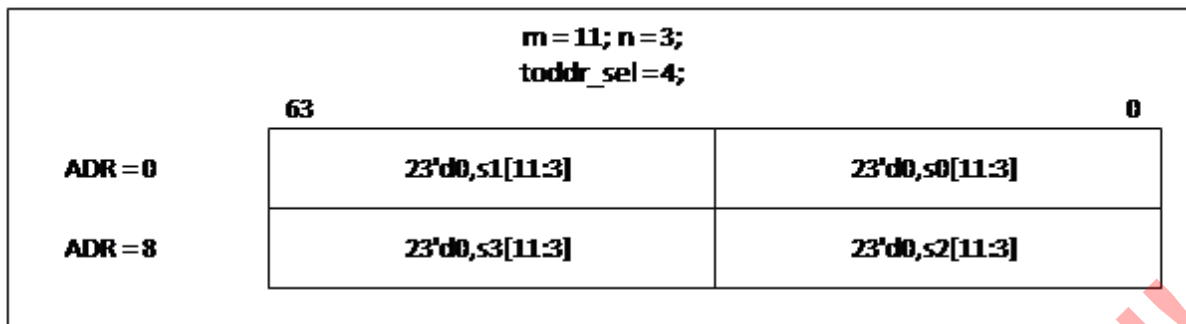

**Table 10-28 EE\_AUDIO\_TODDR\_A\_CTRL1 0x41**

Bits	R/W	Default	Description
31:28	R/W	0x0000-0000	Src select: 0: tadmin_a; 1: tadmin_b; 2: tadmin_c; 3: spdifin; 4: pdmin; 5: fratv; 6: tadmin_lb; 7: loopback_a; 8: frhdmirx; 9: loopback_b; 10: spdifin_lb; 15: vad;
27	R/W		Select from resample_A
26	R/W		Select from resample_B
25	R/W		force_finish; the value from 0-> 1: force finish by current address and jump to start_address;
24	R/W		Insert_chnum; 0: disable; 1: insert chnum[9:0] to data[9:0]
23:12	R/W		reg_fifo_start_rd_th, each time, when fifo_cnt greater than this register, control will start read data from fifo and write to DDR; write length is "reg_fifo_start_rd_th + 1" * 8bytes;
11:8	R/W		reg_status_sel, control status2 source;
7:0	R/W		reg_int_status_clr,clear each bits of int_status register

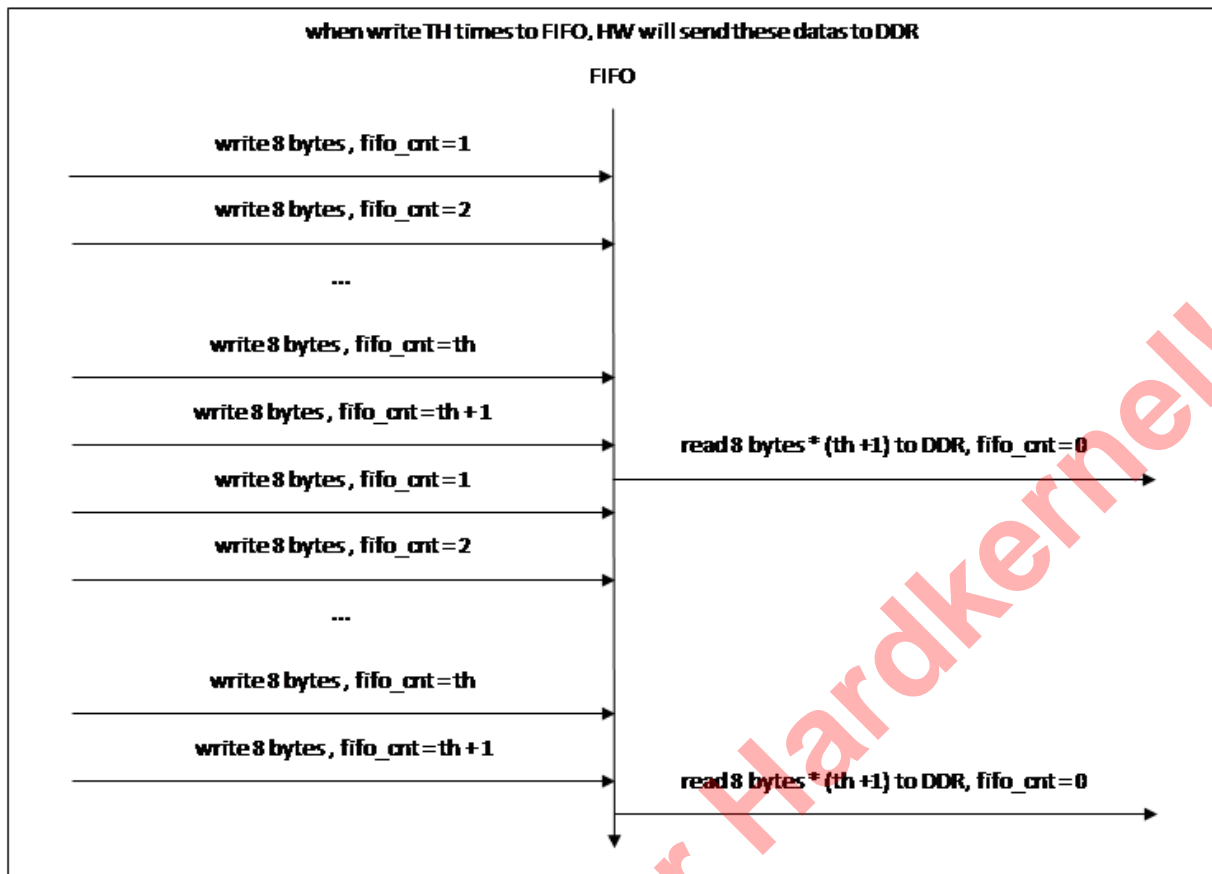

**Table 10-29 EE\_AUDIO\_TODDR\_A\_START\_ADDR 0x42**

Bits	R/W	Default	Description
31:0	R/W	0x0000-0000	start_addr, buff_A start address, ignore [2:0]

**Table 10-30 EE\_AUDIO\_TODDR\_A\_FINISH\_ADDR 0x43**

Bits	R/W	Default	Description
31:0	R/W	0x0000-0000	finish_addr, buff_A finish address, ignore [2:0]

**Table 10-31 EE\_AUDIO\_TODDR\_A\_INT\_ADDR 0x44**

Bits	R/W	Default	Description
31:0	R/W	0x0000-0000	int_addr, usage A : as an address of interrupt; usage B : as a count of interrupt;

**Table 10-32 EE\_AUDIO\_TODDR\_A\_STATUS1 0x45**

Bits	R/W	Default	Description
21	R/W	0x0000-0000	sel_b_true
20	R/W		sel_b
19:8	R/W		fifo count, the num in fifo
7:0	R/W		int_status, when irq generate, related bit will changed to 1 and can only clear by reg_int_status_clr

**Table 10-33 EE\_AUDIO\_TODDR\_A\_STATUS2 0x46**

Bits	R/W	Default	Description
31:0	R/W	0x0000-0000	status2, by reg_status_sel: 0: current ddr write address; 1: next finish address; 2: count by ddr reply, current ddr write address; 3: count by ddr reply, next finish address; 4: ddr address captured by vad flag; 5: ddr address captured by vad frame sync; 6: [31:16]: fifo_cnt captured by vad frame sync; [15:0]: fifo_cnt captured by vad flag;

We can generate 8 irq and add them together to CPU. Then can read int\_status to know which irq it is:

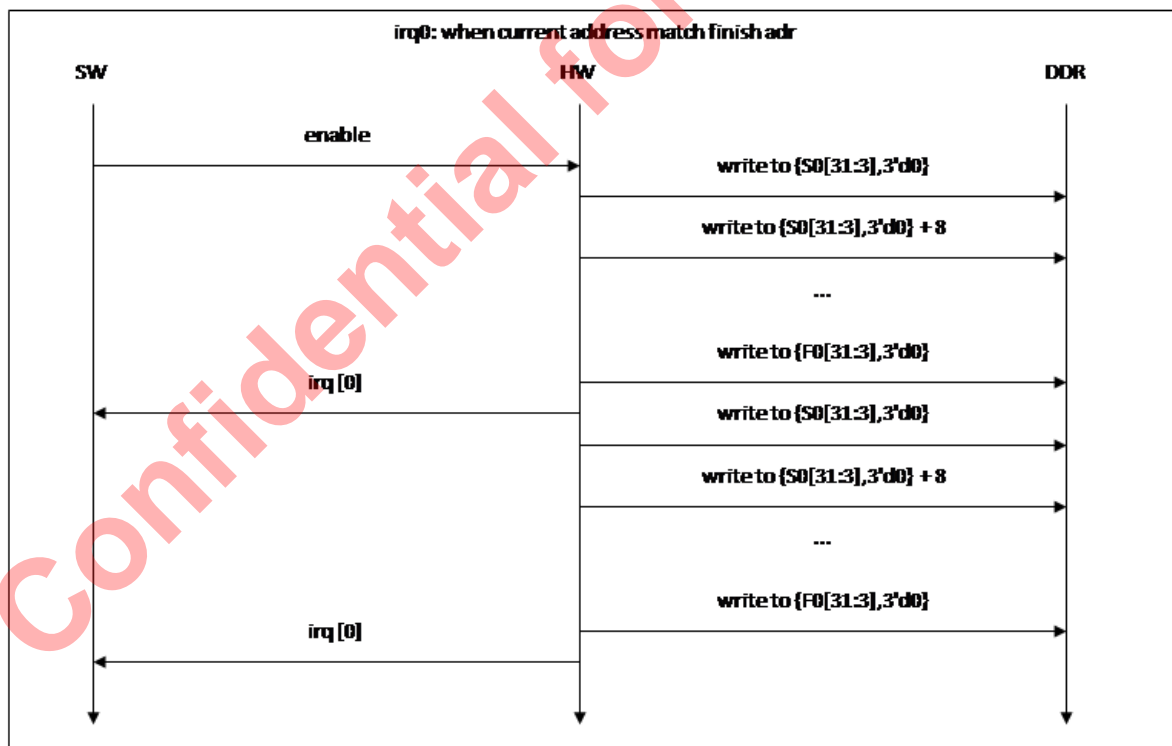

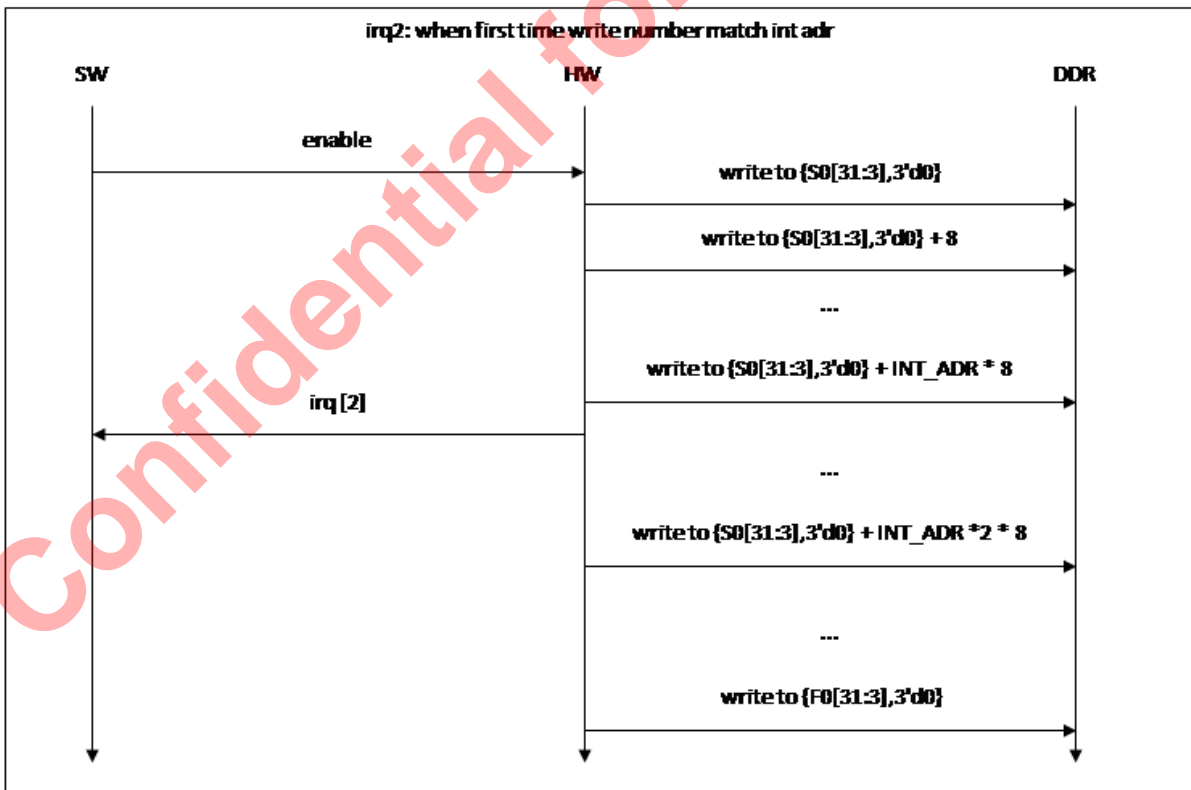



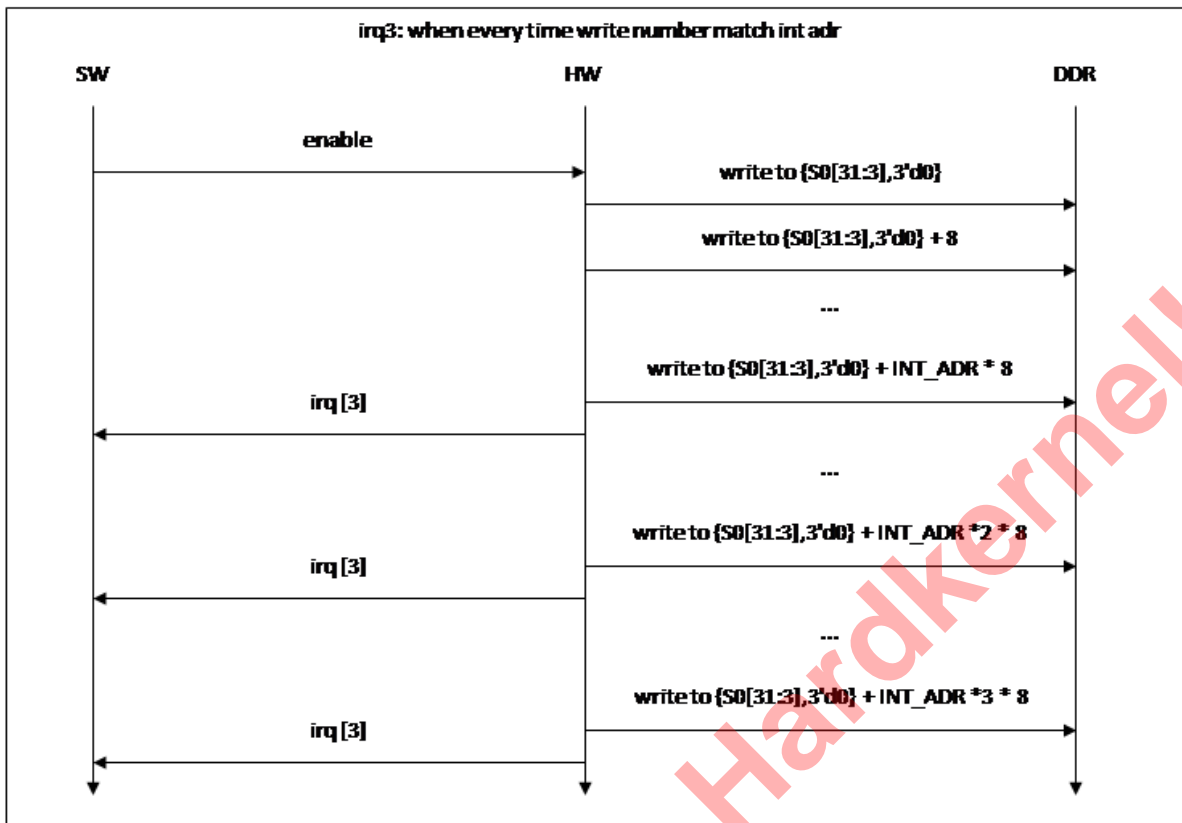

**Table 10-34 EE\_AUDIO\_TODDR\_A\_START\_ADDRB 0x47**

Bits	R/W	Default	Description
31:0	R/W	0x0000-0000	istart_addrb, buff_B start address, ignore [2:0]

**Table 10-35 EE\_AUDIO\_TODDR\_A\_FINISH\_ADDRB 0x48**

Bits	R/W	Default	Description
31:0	R/W	0x0000-0000	finish_addrb, buff_B finish address, ignore [2:0]

**Table 10-36 EE\_AUDIO\_TODDR\_A\_INIT\_ADDR 0x49**

Bits	R/W	Default	Description
31:0	R/W	0x0000-0000	initial address, the first ddr address after enable

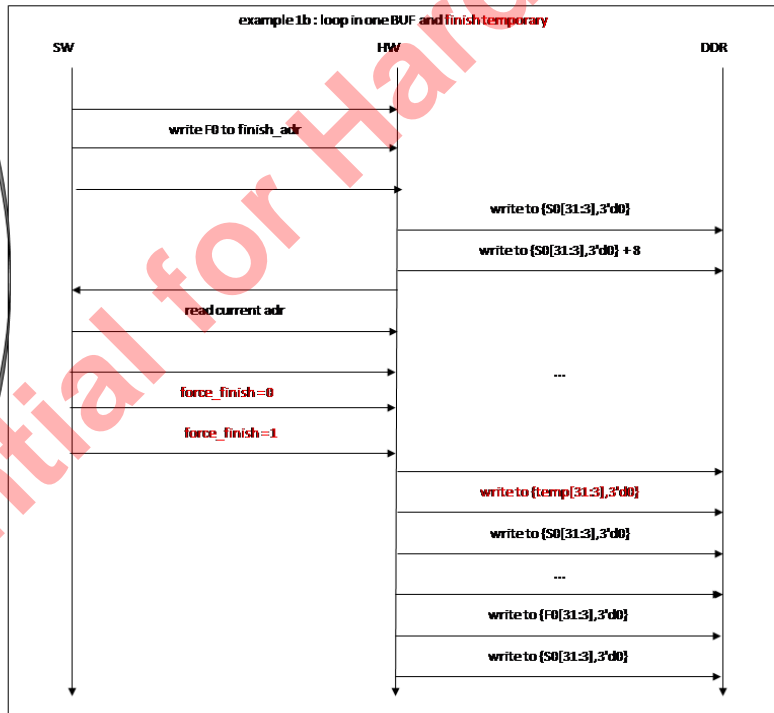
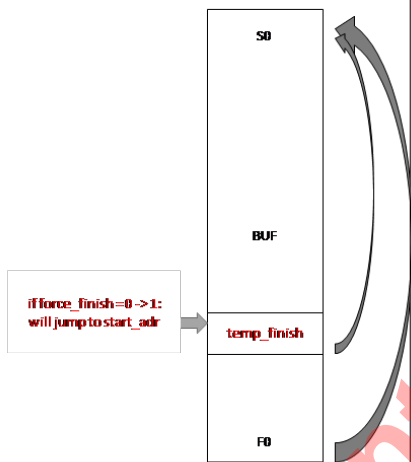
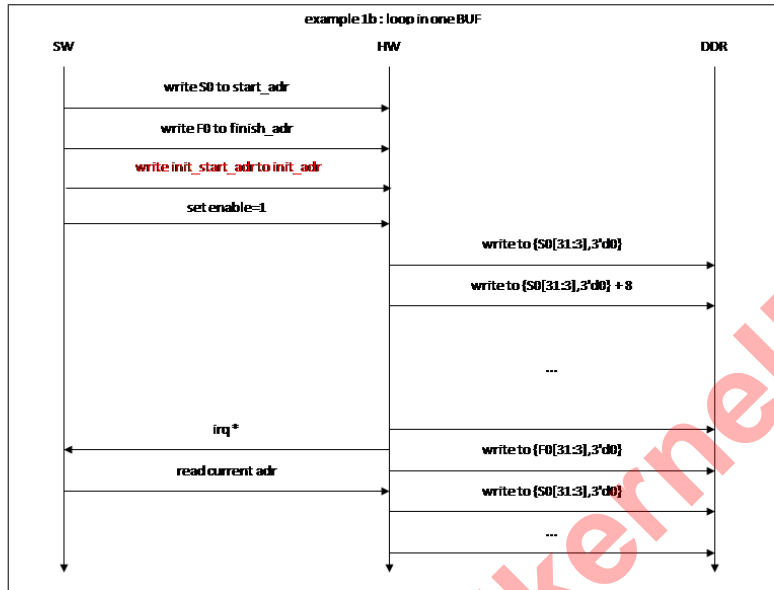
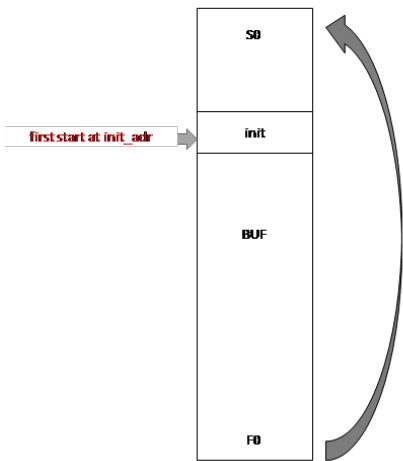

Confidential for Harakernel!

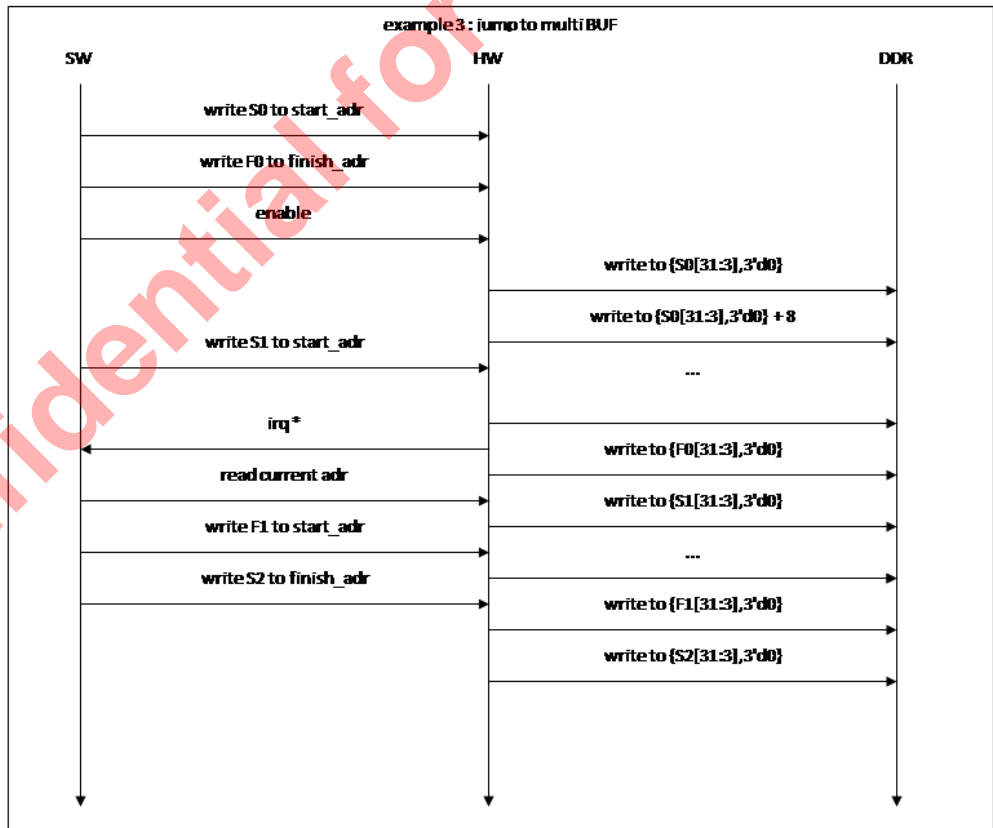
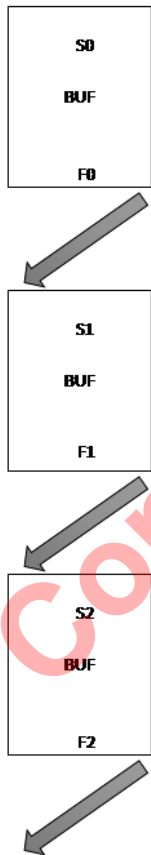
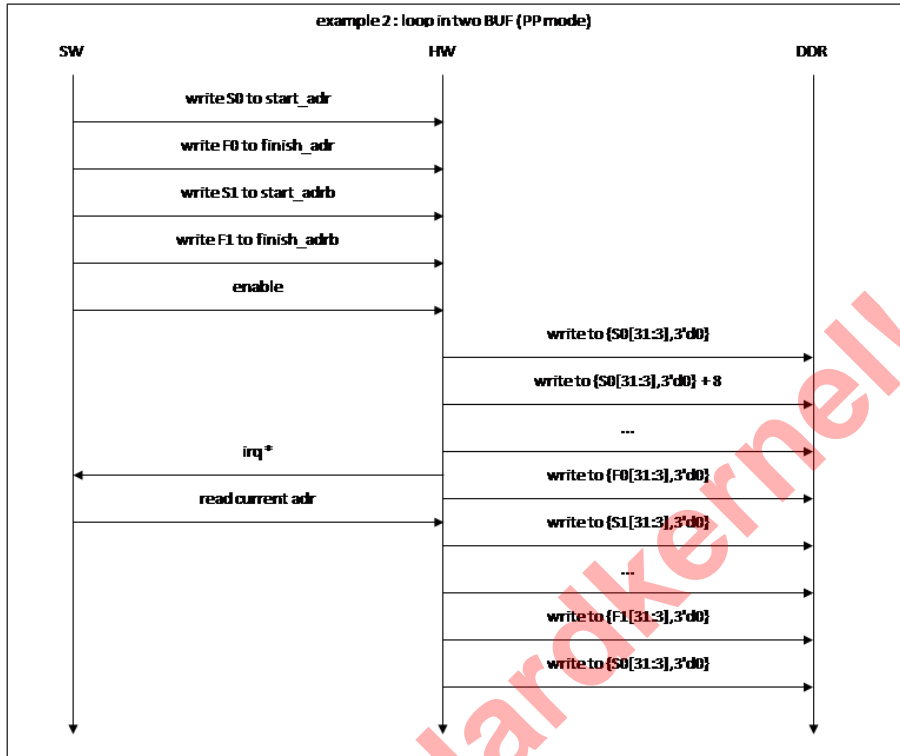
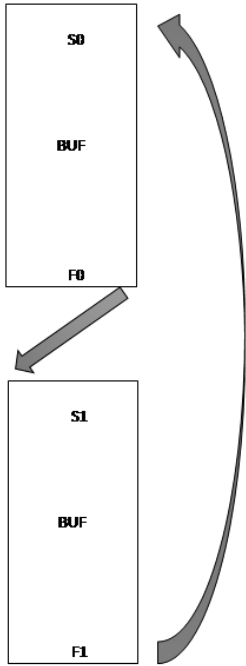

Table 10-37 EE\_AUDIO\_TODDR\_A\_CTRL2 0x4a

Bits	R/W	Default	Description
31	R/W	0x0000-0000	Reserved for hold read.
11:0	R/W		Reserved for hold read start offset.

EE\_AUDIO\_TODDR\_B\_CTRL0 0x50  
 EE\_AUDIO\_TODDR\_B\_CTRL1 0x51  
 EE\_AUDIO\_TODDR\_B\_START\_ADDR 0x52  
 EE\_AUDIO\_TODDR\_B\_FINISH\_ADDR 0x53  
 EE\_AUDIO\_TODDR\_B\_INT\_ADDR 0x54  
 EE\_AUDIO\_TODDR\_B\_STATUS1 0x55  
 EE\_AUDIO\_TODDR\_B\_STATUS2 0x56  
 EE\_AUDIO\_TODDR\_B\_START\_ADDRB 0x57  
 EE\_AUDIO\_TODDR\_B\_FINISH\_ADDR 0x58  
 EE\_AUDIO\_TODDR\_B\_INIT\_ADDR 0x59  
 EE\_AUDIO\_TODDR\_B\_CTRL2 0x5a  
  
 EE\_AUDIO\_TODDR\_C\_CTRL0 0x60  
 EE\_AUDIO\_TODDR\_C\_CTRL1 0x61  
 EE\_AUDIO\_TODDR\_C\_START\_ADDR 0x62  
 EE\_AUDIO\_TODDR\_C\_FINISH\_ADDR 0x63  
 EE\_AUDIO\_TODDR\_C\_INT\_ADDR 0x64  
 EE\_AUDIO\_TODDR\_C\_STATUS1 0x65  
 EE\_AUDIO\_TODDR\_C\_STATUS2 0x66  
 EE\_AUDIO\_TODDR\_C\_START\_ADDRB 0x67  
 EE\_AUDIO\_TODDR\_C\_FINISH\_ADDR 0x68  
 EE\_AUDIO\_TODDR\_C\_INIT\_ADDR 0x69  
 EE\_AUDIO\_TODDR\_C\_CTRL2 0x6a  
  
 EE\_AUDIO\_TODDR\_D\_CTRL0 0x210  
 EE\_AUDIO\_TODDR\_D\_CTRL1 0x211  
 EE\_AUDIO\_TODDR\_D\_START\_ADDR 0x212  
 EE\_AUDIO\_TODDR\_D\_FINISH\_ADDR 0x213  
 EE\_AUDIO\_TODDR\_D\_INT\_ADDR 0x214  
 EE\_AUDIO\_TODDR\_D\_STATUS1 0x215  
 EE\_AUDIO\_TODDR\_D\_STATUS2 0x216  
 EE\_AUDIO\_TODDR\_D\_START\_ADDRB 0x217

EE\_AUDIO\_TODDR\_D\_FINISH\_ADDR 0x218

EE\_AUDIO\_TODDR\_D\_INIT\_ADDR 0x219

EE\_AUDIO\_TODDR\_D\_CTRL2 0x21a

### 10.11.3 FRDDR Registers

**Table 10-38 FRDDR Registers EE\_AUDIO\_FRDDR\_A\_CTRL0 0x70**

Bits	R/W	Default	Description
31	R/W	0x0000-0000	reg_frddr_en, 0: disable; 1: enable;
30	R/W		reg_frddr_pp_mode, 0: select write to only one buff (start_addr,finish_addr); 1: select write to two buff (start_addr,finish_addr) (start_addrb, finish_addrb);
26:24	R/W		reg_frdd_endian
23:16	R/W		reg_frddr_int_en, [23] : reserved; [22] : reserved; [21] : fifo overflow, write when fifocnt = depth; [20] : fifo overflow, read when fifocnt = 0; [19] : first time when read from ddr "int_addr" data(only once); [18] : once time when read from ddr "int_addr" data(repeat); [17] : when read from ddr address match "int_addr"; [16] : when read from ddr address match "finish_addr";
15:12	R/W		reg_frddr_ack_dly, add delay to frddr ack
0	R/W		Ddr bus ugt setting.

**Table 10-39 EE\_AUDIO\_FRDDR\_A\_CTRL1 0x71**

Bits	R/W	Default	Description
31:24	R/W	0x0000-0000	reg_fifo_depth, the max depth of fifo; for high bit rates like 384k*32bits*8ch, set this register higher; for low bit rates like 48k*32bits*2ch, set this register lower;
23:16			reg_fifo_start_wr_th, when the fifo cnt less than "reg_fifo_depth - reg_fifo_start_wr_th", start request and read data from DDR; each time request "reg_fifo_start_wr_th" * 8 bytes data;
12			force finish; when the value changed from 0 to 1; will finished by current address and jump to start address;
11:8			reg_status_sel, control status2 source;
7:0			reg_int_status_clr, clear each bits of int_status register

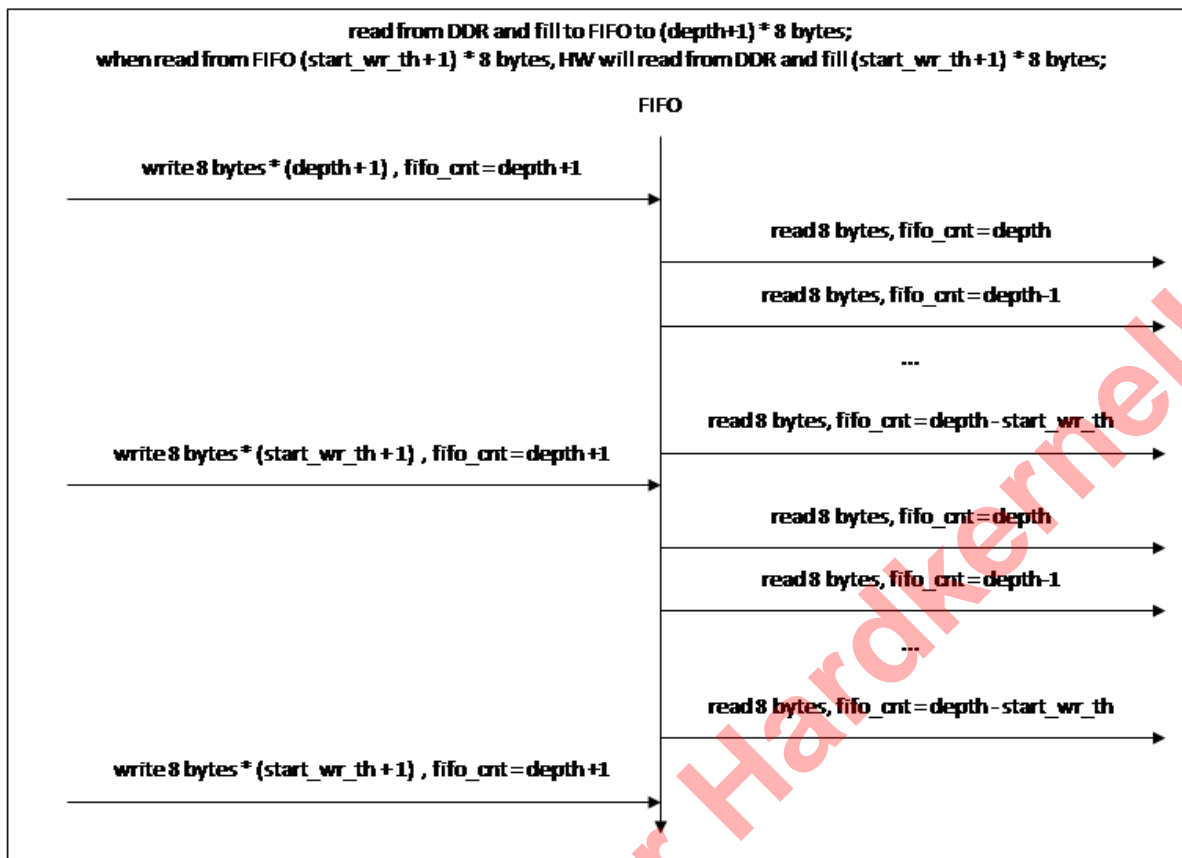

Table 10-40 EE\_AUDIO\_FRDDR\_A\_START\_ADDR 0x72

Bits	R/W	Default	Description
31:0	R/W	0x0000-0000	start_addr, buff_B start address

Table 10-41 EE\_AUDIO\_FRDDR\_A\_FINISH\_ADDR 0x73

Bits	R/W	Default	Description
31:0	R/W	0x0000-0000	finish_addr, buff_B finish address

Table 10-42 EE\_AUDIO\_FRDDR\_A\_INT\_ADDR 0x74

Bits	R/W	Default	Description
31:0	R/W	0x0000-0000	int_addr, usage A : as an address of interrupt; usage B : as a count of interrupt;

**Table 10-43 EE\_AUDIO\_FRDDR\_A\_STATUS1 0x75**

Bits	R/W	Default	Description
19	R/W	0x0000-0000	r_selb_true
18	R/W		r_selb
17:8	R/W		fifo count, the num in fifo
7:0	R/W		int_status, when irq generate, related bit will changed to 1 and can only clear by reg_int_status_clr

**Table 10-44 EE\_AUDIO\_FRDDR\_A\_STATUS2 0x76**

Bits	R/W	Default	Description
31:0	R/W	0x0000-0000	status2, by reg_status_sel: 0: current ddr write address; 1: next finish address; 2: count by ddr reply, current ddr write address; 3: count by ddr reply, next finish address;

The same design as TODDR:

We can generate 8 irq and add them together to CPU.

Then can read int\_status to know it's which irq.

EE\_AUDIO\_FRDDR\_A\_START\_ADDRB 0x77

EE\_AUDIO\_FRDDR\_A\_FINISH\_ADDRB 0x78

The same design as TODDR:

We have an internal register to store reg\_start\_adr and reg\_finish\_adr.

We call them as r\_start\_adr and r\_finish\_adr;

Each time, when curr\_adr match r\_finish\_adr, curr\_adr will jump to r\_start\_adr, then update r\_start\_adr and r\_finish\_adr;

That's mean SW can write new start adr and finish adr before curr\_adr match old finish adr.

**Table 10-45 EE\_AUDIO\_FRDDR\_A\_CTRL2 0x7a**

Bits	R/W	Default	Description
31:24	R/W	0x0000-0000	ch num for share buffer feature; if needn't share buffer, set it as 0; if need share buffer, set it as TDMOUT/SPDIFOUT ch number;
20	R/W		Src_sel2_en
19	R/W		Src_sel2_eq; 1: select request from EQDRC; 0: select request from TDMOUT/SPDIFOUT;
18:16	R/W		Src_sel2; 0: tdmout_a; 1: tdmout_b; 2: tdmout_c; 3: spdifout; 4: spdifout_b; 5: reserved; 6: reserved; 7: reserved;

Bits	R/W	Default	Description
12	R/W		Src_sel1_en
11	R/W		Src_sel1_eq; 1: select request from EQDRC; 0: select request from TDMOUT/SPDIFOUT;
10:8	R/W		Src_sel1; 0: tdmout_a; 1: tdmout_b; 2: tdmout_c; 3: spdifout; 4: spdifout_b; 5: reserved; 6: reserved; 7: reserved;
4	R/W		Src_sel0_en
3	R/W		Src_sel0_eq; 1: select request from EQDRC; 0: select request from TDMOUT/SPDIFOUT;
2:0	R/W		Src_sel0; 0: tdmout_a; 1: tdmout_b; 2: tdmout_c; 3: spdifout; 4: spdifout_b; 5: reserved; 6: reserved; 7: reserved;

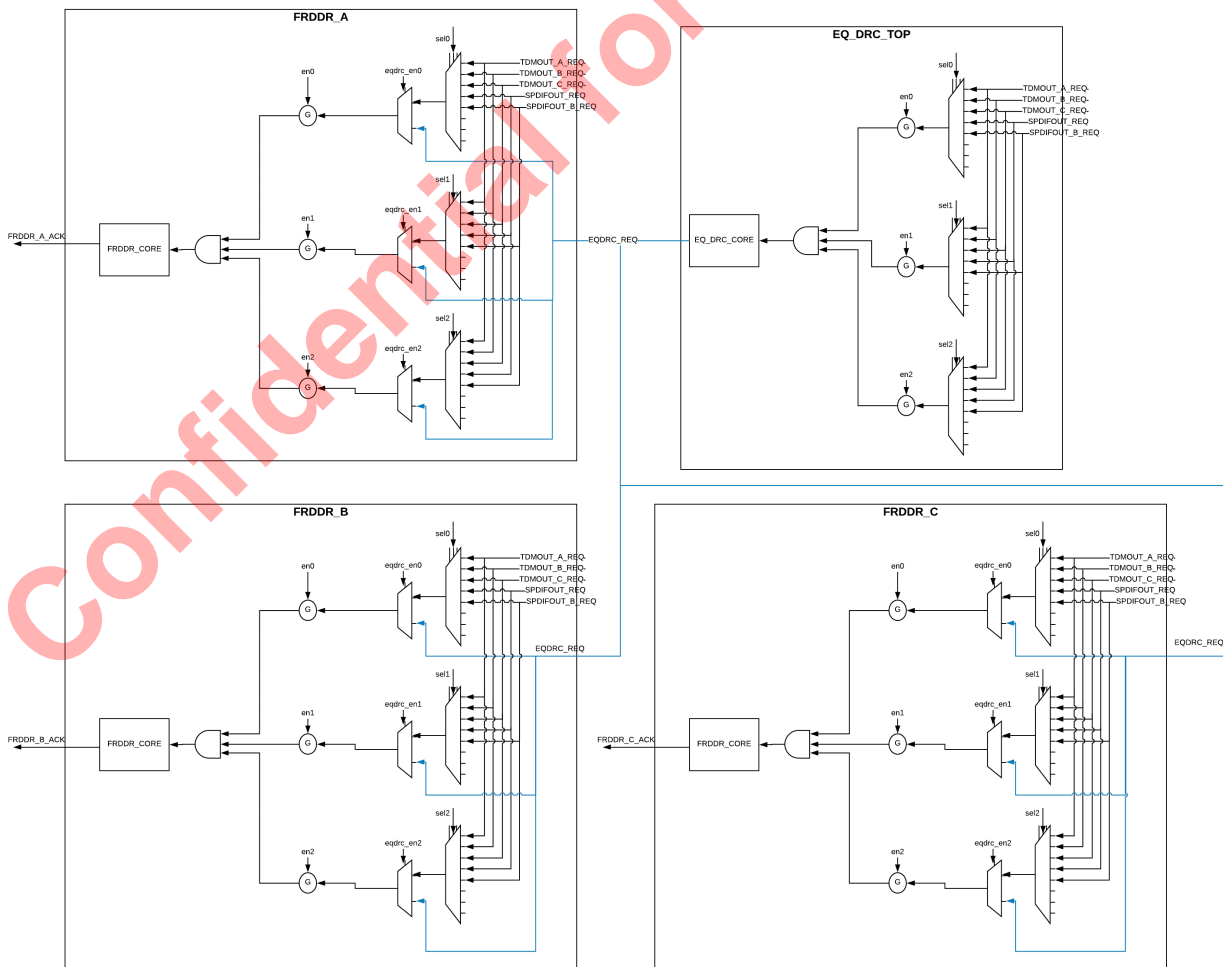



EE_AUDIO_FRDDR_B_CTRL0	0x80
EE_AUDIO_FRDDR_B_CTRL1	0x81
EE_AUDIO_FRDDR_B_START_ADDR	0x82
EE_AUDIO_FRDDR_B_FINISH_ADDR	0x83
EE_AUDIO_FRDDR_B_INT_ADDR	0x84
EE_AUDIO_FRDDR_B_STATUS1	0x85
EE_AUDIO_FRDDR_B_STATUS2	0x86
EE_AUDIO_FRDDR_B_START_ADDRB	0x87
EE_AUDIO_FRDDR_B_FINISH_ADDR	0x88
EE_AUDIO_FRDDR_B_INIT_ADDR	0x89
EE_AUDIO_FRDDR_B_CTRL2	0x8a
EE_AUDIO_FRDDR_C_CTRL0	0x90
EE_AUDIO_FRDDR_C_CTRL1	0x91
EE_AUDIO_FRDDR_C_START_ADDR	0x92
EE_AUDIO_FRDDR_C_FINISH_ADDR	0x93
EE_AUDIO_FRDDR_C_INT_ADDR	0x94
EE_AUDIO_FRDDR_C_STATUS1	0x95
EE_AUDIO_FRDDR_C_STATUS2	0x96
EE_AUDIO_FRDDR_C_START_ADDRB	0x97
EE_AUDIO_FRDDR_C_FINISH_ADDR	0x98
EE_AUDIO_FRDDR_C_INIT_ADDR	0x99
EE_AUDIO_FRDDR_C_CTRL2	0x9a
EE_AUDIO_FRDDR_D_CTRL0	0x220
EE_AUDIO_FRDDR_D_CTRL1	0x221
EE_AUDIO_FRDDR_D_START_ADDR	0x222
EE_AUDIO_FRDDR_D_FINISH_ADDR	0x223
EE_AUDIO_FRDDR_D_INT_ADDR	0x224
EE_AUDIO_FRDDR_D_STATUS1	0x225
EE_AUDIO_FRDDR_D_STATUS2	0x226
EE_AUDIO_FRDDR_D_START_ADDRB	0x227
EE_AUDIO_FRDDR_D_FINISH_ADDR	0x228
EE_AUDIO_FRDDR_D_INIT_ADDR	0x229
EE_AUDIO_FRDDR_D_CTRL2	0x22a

### 10.11.4 DDR ARB Registers

Table 10-46 EE\_AUDIO\_ARB\_CTRL 0xa0

Bits	R/W	Default	Description
31	R/W	0x0000-0000	reg_arb_en, 0:disable; 1: enable;
7:0	R/W		reg_arb_mask, [7]: frddr_d; [6]: frddr_c; [5]: frddr_b; [4]: frddr_a; [3]: toddr_d; [2]: toddr_c; [1]: toddr_b; [0]: toddr_a;

### 10.11.5 LoopBack Registers

Table 10-47 EE\_AUDIO\_LB\_A\_CTRL0 0xb0

Bits	R/W	Default	Description
31	R/W	0x0000-0000	reg_lb_en, 0:disable; 1: enable;
30	R/W		reg_lb_mode, 0: out rate = in data rate; 1: out rate = loopback data rate;
29	R/W		reg_ext_signed, 0: extend bits as "0"; 1: extend bits as "msb";
28	R/W		Enable_sync_chnum; 1: start store data when ch_num can match ID;
27	R/W		chnum_en; 1: start send new ch num out;
17:16	R/W		Reg_sts_sel, refer to REG_LB_STATUS.
15:13	R/W		reg_dat_sel, shift [m:n] to [31:0]; 0: right justified, out = { ext,[m:n]}; 1: left justified, out = {[m:n],all0}; 2: right justified, out = { ext,[m:n]}; 3: left justified, out = {[m:n],all0}; 4: right justified, out = { ext,[m:n]};
12:8	R/W		reg_dat_m_sel, the msb position in data
7:3	R/W		reg_dat_n_sel, the lsb position in data
2:0	R/W		reg_dat_src_sel, [7]: reserved; [6]: reserved; [5]: for loopbackB, will select loopbackA output; [4]: pdmin; [3]: spdifin; [2]: tadmin_c; [1]: tadmin_b; [0]: tadmin_a;

Table 10-48 EE\_AUDIO\_LB\_A\_CTRL1 0xb1

Bits	R/W	Default	Description
31	R/W	0x0000-0000	Lb_sel_resampleA;1: select from resample A
30	R/W		Lb_sel_resampleB;1: select from resample B; need set Lb_sel_resampleA = 0;
29	R/W		reg_lb_ext_signed, 0: extend bits as "0"; 1: extend bits as "msb";
28	R/W		Enable_sync_chnum; 1: start store data when ch_num can match ID;
27	R/W		hold_insertion 1: hold insert data store(update) and insert 0 after original data;
15:13			reg_lb_sel, shift [m:n] to [31:0]; 0: right justified, out = {ext,[m:n]}; 1: left justified, out = {[m:n],all0}; 2: right justified, out = { ext,[m:n]}; 3: left justified, out = {[m:n], all0}; 4: right justified, out = { ext,[m:n]};
12:8			reg_lb_m_sel, the msb position loopback data
7:3			reg_lb_n_sel, the lsb position loopback data
0			Lb src sel; 1: spdifin_lb; 0: tadmin_lb;

Table 10-49 EE\_AUDIO\_LB\_A\_CTRL2 0xb2

Bits	R/W	Default	Description
19:16	R/W	0x0000-0000	Dat_ch_num, max channel number of data source; max is 15 (equal 16 ch)
15:0	R/W		Dat_ch_mask, 16bits match 16 ch, set 1 will sending out, set0 will drop off this ch;

Table 10-50 EE\_AUDIO\_LB\_A\_CTRL3 0xb3

Bits	R/W	Default	Description
19:16	R/W	0x0000-0000	Lb_ch_num, max channel number of data source; max is 15 (equal 16 ch)
15:0	R/W		Lb_ch_mask, 16bits match 16 ch, set 1 will sending out, set0 will drop off this ch;

Table 10-51 EE\_AUDIO\_LB\_A\_DAT\_ID0 0xb4

Bits	R/W	Default	Description
31:24	R/W	0x0000-0000	data_ch7_id
23:16	R/W		data_ch6_id
15:8	R/W		data_ch5_id
7:0	R/W		data_ch4_id

**Table 10-52 EE\_AUDIO\_LB\_A\_DAT\_ID1 0xb5**

Bits	R/W	Default	Description
31:24	R/W	0x0000-0000	data_ch3_id
23:16	R/W		data_ch2_id
15:8	R/W		data_ch1_id
7:0	R/W		data_ch0_id

**Table 10-53 EE\_AUDIO\_LB\_A\_DAT\_ID2 0xb6**

Bits	R/W	Default	Description
31:24	R/W	0x0000-0000	data_ch11_id
23:16	R/W		data_ch10_id
15:8	R/W		data_ch9_id
7:0	R/W		data_ch8_id

**Table 10-54 EE\_AUDIO\_LB\_A\_DAT\_ID3 0xb7**

Bits	R/W	Default	Description
31:24	R/W	0x0000-0000	data_ch15_id
23:16	R/W		data_ch14_id
15:8	R/W		data_ch13_id
7:0	R/W		data_ch12_id

**Table 10-55 EE\_AUDIO\_LB\_A\_ID0 0xb8**

Bits	R/W	Default	Description
31:24	R/W	0x0000-0000	lb_data_ch7_id
23:16	R/W		lb_data_ch6_id
15:8	R/W		lb_data_ch5_id
7:0	R/W		lb_data_ch4_id

**Table 10-56 EE\_AUDIO\_LB\_A\_ID1 0xb9**

Bits	R/W	Default	Description
31:24	R/W	0x0000-0000	lb_data_ch3_id
23:16	R/W		lb_data_ch2_id

Bits	R/W	Default	Description
15:8	R/W		lb_data_ch1_id
7:0	R/W		lb_data_ch0_id

Table 10-57 EE\_AUDIO\_LB\_A\_ID2 0xba

Bits	R/W	Default	Description
31:24	R/W	0x0000-0000	lb_data_ch11_id
23:16	R/W		lb_data_ch10_id
15:8	R/W		lb_data_ch9_id
7:0	R/W		lb_data_ch8_id

Table 10-58 EE\_AUDIO\_LB\_A\_ID3 0xbb

Bits	R/W	Default	Description
31:24	R/W	0x0000-0000	lb_data_ch15_id
23:16	R/W		lb_data_ch14_id
15:8	R/W		lb_data_ch13_id
7:0	R/W		lb_data_ch12_id

Table 10-59 EE\_AUDIO\_LB\_A\_STS 0xbc

Bits	R/W	Default	Description
31:0	R	0x0000-0000	<p>reg_sts_sel = 0: [31:0] = 0;</p> <p>reg_sts_sel = 1: [31]:pipe_cnt_err2; mean pipe cnt decr when it's 0; [30]:pipe_cnt_err1; mean pipe cnt incr when it's 3; [29:28]:pipe_cnt; current pipe cnt value; [27]:output_en_err; when output, received a new start; [26]:insert_storing_err2; it it's receiving, but received first ch; [25]:insert_storing_err1, if it's not receiving, but received data [24]:orig_storing_err2; it it's receiving, but received first ch; [23]:orig_storing_err1, if it's not receiving, but received data [22]:1st_send_done, mean finished first time send insert data; [21]:insert_storing, mean it's receiving insert data now; [20]:orig_storing, mean it's receiving insert data now; [19]:insert_store_cnt_err, when first_ch, if store_cnt is not 0, mean error, missed ch or another reason; [9]:orig_store_cnt_err, when first_ch, if store_cnt is not 0, mean error, missed ch or another reason;</p> <p>reg_sts_sel = 2: [31:0]:insert_store_cnt_debug, when start sending data, stored insert dat ch number;</p> <p>reg_sts_sel = 3: [31:0]:orig_store_cnt_debug, when start sending data, stored orig dat ch number;</p>

EE\_AUDIO\_LB\_B\_CTRL0

0x230

EE_AUDIO_LB_B_CTRL1	0x231
EE_AUDIO_LB_B_CTRL2	0x232
EE_AUDIO_LB_B_CTRL3	0x233
EE_AUDIO_LB_B_DAT_ID0	0x234
EE_AUDIO_LB_B_DAT_ID1	0x235
EE_AUDIO_LB_B_DAT_ID2	0x236
EE_AUDIO_LB_B_DAT_ID3	0x237
EE_AUDIO_LB_B_ID0	0x238
EE_AUDIO_LB_B_ID1	0x239
EE_AUDIO_LB_B_ID2	0x23a
EE_AUDIO_LB_B_ID3	0x23b
EE_AUDIO_LB_B_STS	0x23c

### 10.11.6 TDM Registers

TDMIn\_B/C are the same as TDMIn\_A.

TDMout\_B/C are the same as TDMout\_A.

TDMIn\_LB is the same as TDMIn\_A.

**Table 10-60 EE\_AUDIO\_TDMIN\_A\_CTRL 0xc0**

Bits	R/W	Default	Description
31	R/W	0x0000-0000	reg_work_enable 0:disable; 1:enable;
30	R/W		reg_i2s_mode,0:tdm mode; 1: i2s mode;
29	R/W		reg_rst_afifo_out_n, reset afifo out side; need set to 1 before reg_rst_afifo_in_n;
28	R/W		reg_rst_afifo_in_n, reset afifo in side; need set 1 after set reg_rst_afifo_out_n to 1;
27	R/W		reg_tdmIn_in_debug_en, 0: disable debug mode; 1: enable;
26	R/W		reg_tdmIn_in_auto_en,0: disalbe; 1: enable detect and store max/min of bit_cnt ;
25	R/W		reg_tdmIn_in_rev_ws, revert ws(lrclk); 0 :disable; 1: enable;
24	R/W		reg_tdmIn_in_rev_dat, revert data; 0:disable; 1:enable;
23:20	R/W		select tdmIn src; 0: PAD_TDMINA_DIN*; //for tdmIn_lb, it's tdmoutA 1: PAD_TDMINB_DIN*; //for tdmIn_lb, it's tdmoutB 2: PAD_TDMINC_DIN*; //for tdmIn_lb, it's tdmoutC 3: PAD_TDMINA_D*; //for tdmIn_lb, it's PAD_TDMINA_DIN* 4: PAD_TDMINB_D*; //for tdmIn_lb, it's PAD_TDMINB_DIN* 5: PAD_TDMINC_D*; //for tdmIn_lb, it's PAD_TDMINC_DIN* 6:HDMIRX_I2S; //for tdmIn_lb, it's PAD_TDMINA_D* 7:ACODEC_ADC; //for tdmIn_lb, it's PAD_TDMINB_D* 8:fix0; //for tdmIn_lb, it's PAD_TDMINC_D* 9:fix0; //for tdmIn_lb, it's HDMIRX_I2S 10:fix0; //for tdmIn_lb, it's ACODEC_ADC; 11:fix0; 12:fix0; 13: TDMOUTA; //for tdmIn_lb, it's 0 14: TDMOUTB; //for tdmIn_lb, it's 0 15: TDMOUTC; //for tdmIn_lb, it's 0

Bits	R/W	Default	Description
18:16	R/W		reg_tadmin_in_bit_skew, add delay to ws or data for skew modification;
6	R/W		chnum_en; 1: add ch cnt to chnum;
5	R/W		reg_lsb_first, 0: store first bit received to data_store[0]; 1: store first bit received to data_store[31];
4:0	R/W		reg_tadmin_bit_num, bitwidth of each slot, if slot is 16bits, set this register to 15;

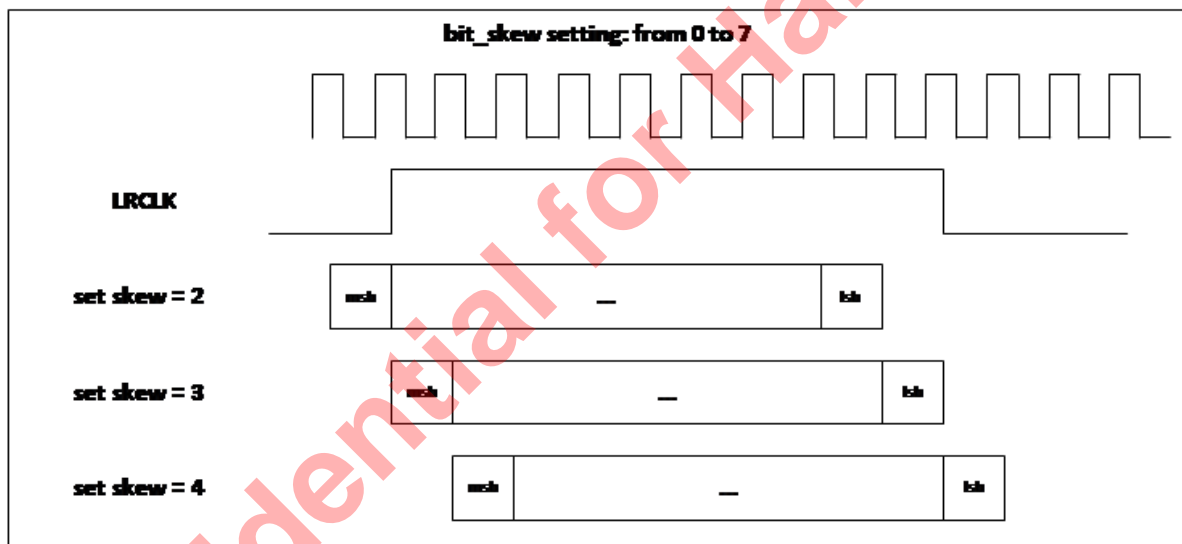
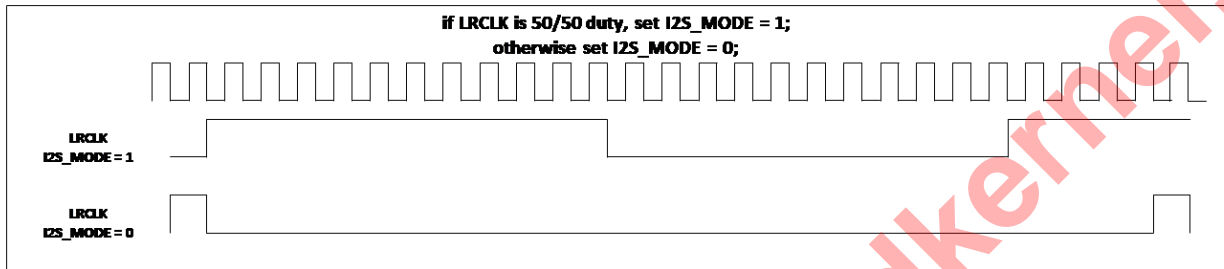

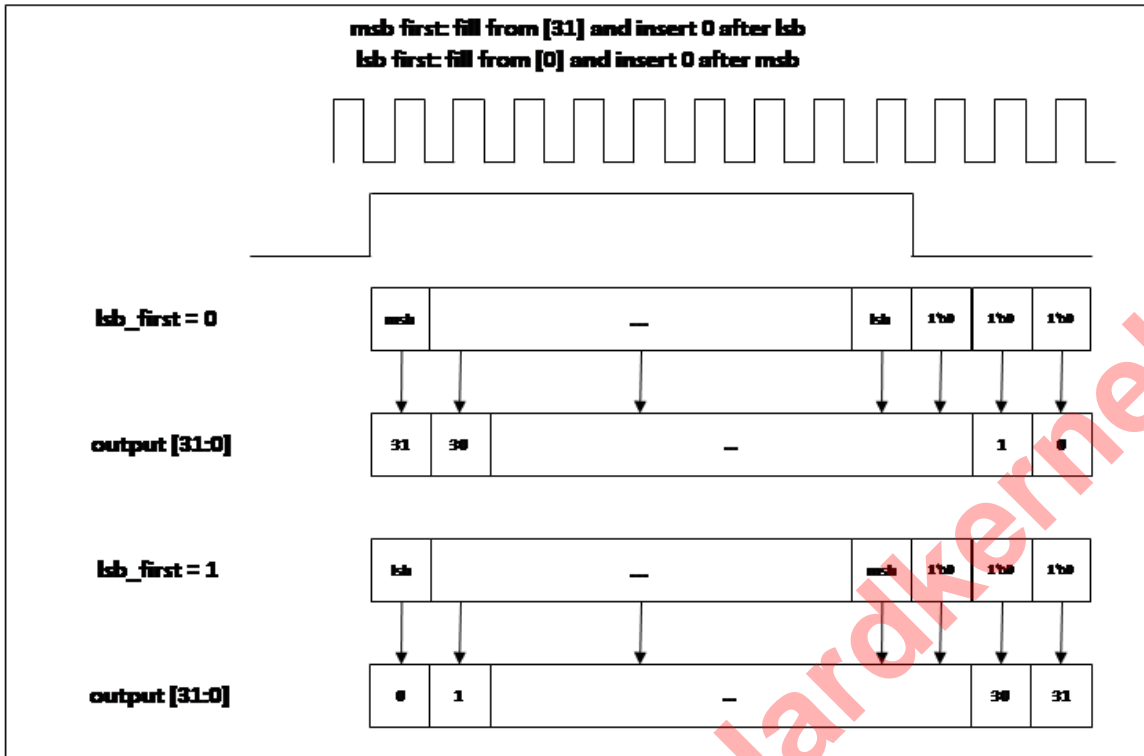

Table 10-61 EE\_AUDIO\_TDMIN\_A\_SWAP0 0xc1

Bits	R/W	Default	Description
31:28	R/W	0x00000000	ch7_sel 0: lane0 left channel; 1: lane0 right channel; 2: lane1 left channel; 3: lane1 right channel; 4: lane2 left channel; 5: lane2 right channel; 6: lane3 left channel; 7: lane3 right channel; 8: lane4 left channel; 9: lane4 right channel; 10: lane5 left channel; 11: lane5 right channel; 12: lane6 left channel; 13: lane6 right channel; 14: lane7 left channel; 15: lane7 right channel;
27:24	R/W		ch6_sel
23:20	R/W		ch5_sel
19:16	R/W		ch4_sel
15:12	R/W		ch3_sel
11:8	R/W		ch2_sel
7:4	R/W		ch1_sel
3:0	R/W		ch0_sel



**Table 10-62 EE\_AUDIO\_TDMIN\_A\_SWAP1 0x260**

Bits	R/W	Default	Description
31:28	R/W	0x00000000	ch15_sel
27:24	R/W		ch14_sel
23:20	R/W		ch13_sel
19:16	R/W		ch12_sel
15:12	R/W		ch11_sel
11:8	R/W		ch10_sel
7:4	R/W		ch9_sel
3:0	R/W		ch8_sel

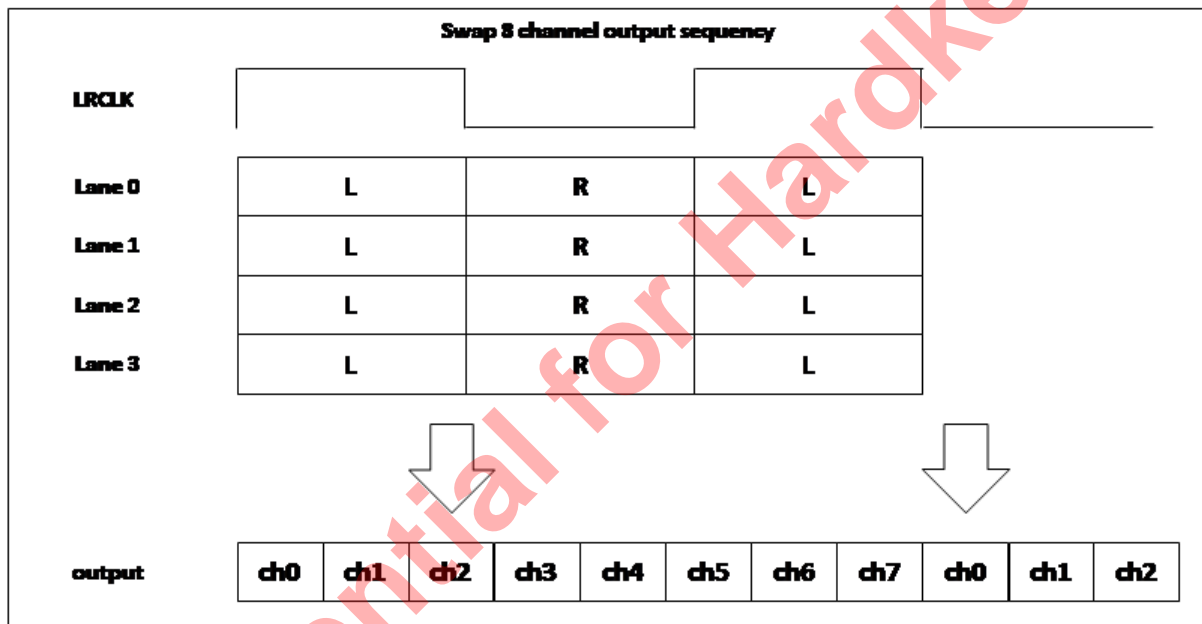

**Table 10-63 EE\_AUDIO\_TDMIN\_A\_MASK0 0xc2**

Bits	R/W	Default	Description
31:0	R/W	0x0000-0000	reg_lane0_mask, mask each channel in lane0, max is 32 ch;

**Table 10-64 EE\_AUDIO\_TDMIN\_A\_MASK1 0xc3**

Bits	R/W	Default	Description
31:0	R/W	0x0000-0000	reg_lane1_mask, mask each channel in lane1, max is 32 ch;

**Table 10-65 EE\_AUDIO\_TDMIN\_A\_MASK2 0xc4**

Bits	R/W	Default	Description
31:0	R/W	0x0000-0000	reg_lane2_mask, mask each channel in lane2, max is 32 ch;

**Table 10-66 EE\_AUDIO\_TDMIN\_A\_MASK3 0xc5**

Bits	R/W	Default	Description
31:0	R/W	0x0000-0000	reg_lane3_mask, mask each channel in lane3, max is 32 ch;

**Table 10-67 EE\_AUDIO\_TDMIN\_A\_MASK4 0x261**

Bits	R/W	Default	Description
31:0	R/W	0x00000000	reg_lane4_mask, mask each channel in lane4, max is 32 ch;

**Table 10-68 EE\_AUDIO\_TDMIN\_A\_MASK5 0x262**

Bits	R/W	Default	Description
31:0	R/W	0x00000000	reg_lane5_mask, mask each channel in lane5, max is 32 ch;

**Table 10-69 EE\_AUDIO\_TDMIN\_A\_MASK6 0x263**

Bits	R/W	Default	Description
31:0	R/W	0x00000000	reg_lane6_mask, mask each channel in lane6, max is 32 ch;

**Table 10-70 EE\_AUDIO\_TDMIN\_A\_MASK7 0x264**

Bits	R/W	Default	Description
31:0	R/W	0x00000000	reg_lane7_mask, mask each channel in lane7, max is 32 ch;

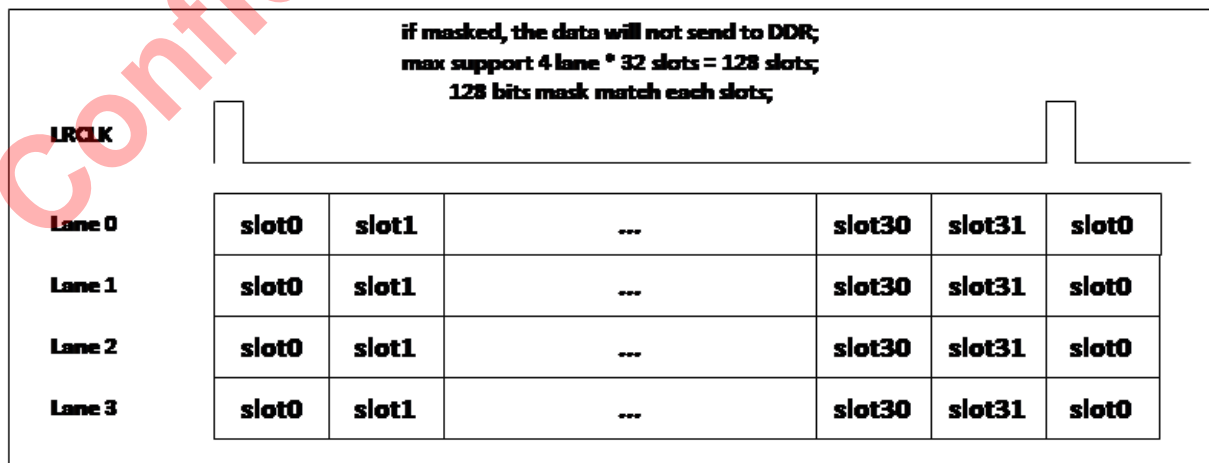

**Table 10-71 EE\_AUDIO\_TDMIN\_A\_STAT 0xc6**

Bits	R/W	Default	Description
31:24	R/W	0x0000-0000	r_input_slot_cnt_max, the maxnum of slot_cnt
23:16	R/W		r_input_slot_cnt_min, the minnum of slot_cnt
14	R/W		overflow_flag, overflow flag of afifo
13:10	R/W		max_fifo_cnt, the maxnum of afifo_cnt
9:5	R/W		r_input_bit_cnt_max, the maxnum of bit_cnt
4:0	R/W		r_input_bit_cnt_min, the minnum of bit_cnt

**Table 10-72 EE\_AUDIO\_TDMIN\_A\_MUTE\_VAL 0xc7**

Bits	R/W	Default	Description
31:0	R/W	0x0000-0000	reg_tmdin_a_mute_val, when mute , the channel value

**Table 10-73 EE\_AUDIO\_TDMIN\_A\_MUTE0 0xc8**

Bits	R/W	Default	Description
31:0	R/W	0x0000-0000	reg_lane0_mute, mute each channel in lane0, max is 32 ch;

**Table 10-74 EE\_AUDIO\_TDMIN\_A\_MUTE1 0xc9**

Bits	R/W	Default	Description
31:0	R/W	0x0000-0000	reg_lane1_mute, mute each channel in lane1, max is 32 ch;

**Table 10-75 EE\_AUDIO\_TDMIN\_A\_MUTE2 0xca**

Bits	R/W	Default	Description
31:0	R/W	0x0000-0000	reg_lane2_mute, mute each channel in lane2, max is 32 ch;

**Table 10-76 EE\_AUDIO\_TDMIN\_A\_MUTE3 0xcb**

Bits	R/W	Default	Description
31:0	R/W	0x0000-0000	reg_lane3_mute, mute each channel in lane3, max is 32 ch;

**Table 10-77 EE\_AUDIO\_TDMIN\_A\_MUTE4 0x265**

Bits	R/W	Default	Description
31:0	R/W	0x000000-00	reg_lane4_mute, mute each channel in lane4, max is 32 ch;

**Table 10-78 EE\_AUDIO\_TDMIN\_A\_MUTE5 0x266**

Bits	R/W	Default	Description
31:0	R/W	0x000000-00	reg_lane5_mute, mute each channel in lane5, max is 32 ch;

**Table 10-79 EE\_AUDIO\_TDMIN\_A\_MUTE6 0x267**

Bits	R/W	Default	Description
31:0	R/W	0x00000000	reg_lane6_mute, mute each channel in lane6, max is 32 ch;

**Table 10-80 EE\_AUDIO\_TDMIN\_A\_MUTE7 0x268**

Bits	R/W	Default	Description
31:0	R/W	0x00000000	reg_lane7_mute, mute each channel in lane7, max is 32 ch;

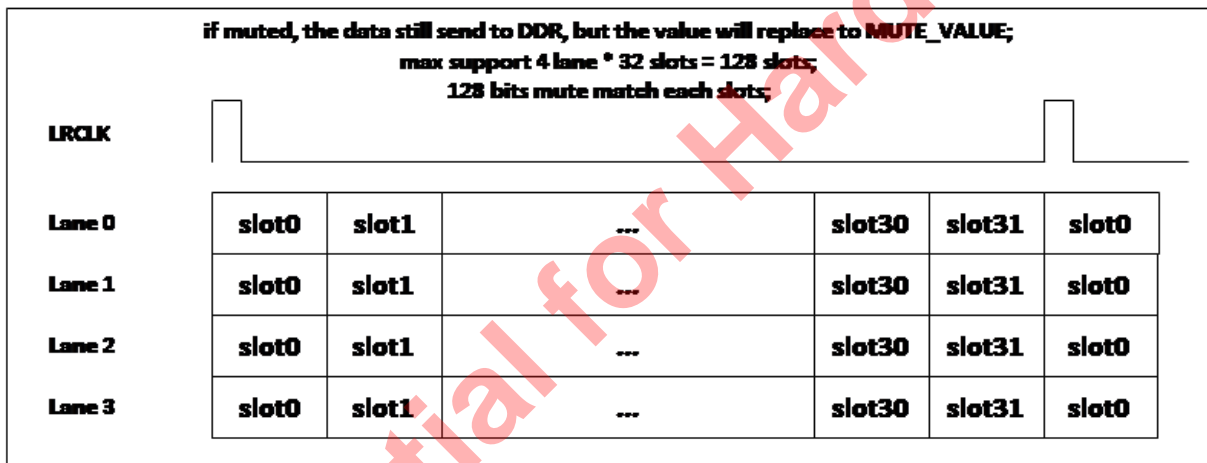

- EE\_AUDIO\_TDMIN\_B\_CTRL 0xd0
- EE\_AUDIO\_TDMIN\_B\_SWAP0 0xd1
- EE\_AUDIO\_TDMIN\_B\_SWAP1 0x270
- EE\_AUDIO\_TDMIN\_B\_MASK0 0xd2
- EE\_AUDIO\_TDMIN\_B\_MASK1 0xd3
- EE\_AUDIO\_TDMIN\_B\_MASK2 0xd4
- EE\_AUDIO\_TDMIN\_B\_MASK3 0xd5
- EE\_AUDIO\_TDMIN\_B\_MASK4 0x271
- EE\_AUDIO\_TDMIN\_B\_MASK5 0x272
- EE\_AUDIO\_TDMIN\_B\_MASK6 0x273
- EE\_AUDIO\_TDMIN\_B\_MASK7 0x274
- EE\_AUDIO\_TDMIN\_B\_STAT 0xd6
- EE\_AUDIO\_TDMIN\_B\_MUTE\_VAL 0xd7

EE_AUDIO_TDMIN_B_MUTE0	0xd8
EE_AUDIO_TDMIN_B_MUTE1	0xd9
EE_AUDIO_TDMIN_B_MUTE2	0xda
EE_AUDIO_TDMIN_B_MUTE3	0xdb
EE_AUDIO_TDMIN_B_MUTE4	0x275
EE_AUDIO_TDMIN_B_MUTE5	0x276
EE_AUDIO_TDMIN_B_MUTE6	0x277
EE_AUDIO_TDMIN_B_MUTE7	0x278
EE_AUDIO_TDMIN_C_CTRL	0xe0
EE_AUDIO_TDMIN_C_SWAP0	0xe1
EE_AUDIO_TDMIN_C_SWAP1	0x280
EE_AUDIO_TDMIN_C_MASK0	0xe2
EE_AUDIO_TDMIN_C_MASK1	0xe3
EE_AUDIO_TDMIN_C_MASK2	0xe4
EE_AUDIO_TDMIN_C_MASK3	0xe5
EE_AUDIO_TDMIN_C_MASK4	0x281
EE_AUDIO_TDMIN_C_MASK5	0x282
EE_AUDIO_TDMIN_C_MASK6	0x283
EE_AUDIO_TDMIN_C_MASK7	0x284
EE_AUDIO_TDMIN_C_STAT	0xe6
EE_AUDIO_TDMIN_C_MUTE_VAL	0xe7
EE_AUDIO_TDMIN_C_MUTE0	0xe8
EE_AUDIO_TDMIN_C_MUTE1	0xe9
EE_AUDIO_TDMIN_C_MUTE2	0xea
EE_AUDIO_TDMIN_C_MUTE3	0xeb
EE_AUDIO_TDMIN_C_MUTE4	0x285
EE_AUDIO_TDMIN_C_MUTE5	0x286
EE_AUDIO_TDMIN_C_MUTE6	0x287
EE_AUDIO_TDMIN_C_MUTE7	0x288
EE_AUDIO_TDMIN_LB_CTRL	0xf0
EE_AUDIO_TDMIN_LB_SWAP0	0xf1
EE_AUDIO_TDMIN_LB_SWAP1	0x290
EE_AUDIO_TDMIN_LB_MASK0	0xf2
EE_AUDIO_TDMIN_LB_MASK1	0xf3
EE_AUDIO_TDMIN_LB_MASK2	0xf4
EE_AUDIO_TDMIN_LB_MASK3	0xf5

EE_AUDIO_TDMIN_LB_MASK4	0x291
EE_AUDIO_TDMIN_LB_MASK5	0x292
EE_AUDIO_TDMIN_LB_MASK6	0x293
EE_AUDIO_TDMIN_LB_MASK7	0x294
EE_AUDIO_TDMIN_LB_STAT	0xf6
EE_AUDIO_TDMIN_LB_MUTE_VAL	0xf7
EE_AUDIO_TDMIN_LB_MUTE0	0xf8
EE_AUDIO_TDMIN_LB_MUTE1	0xf9
EE_AUDIO_TDMIN_LB_MUTE2	0xfa
EE_AUDIO_TDMIN_LB_MUTE3	0xfb
EE_AUDIO_TDMIN_LB_MUTE4	0x295
EE_AUDIO_TDMIN_LB_MUTE5	0x296
EE_AUDIO_TDMIN_LB_MUTE6	0x297
EE_AUDIO_TDMIN_LB_MUTE7	0x298

**Table 10-81 EE\_AUDIO\_TDMOUT\_A\_CTRL0 0x140**

Bits	R/W	Default	Description
31	R/W	0x0000-0000	reg_work_enable, 0:disable; 1:enable;
29	R/W		reg_rst_afifo_out_n, reset afifo out side;
28	R/W		reg_rst_afifo_in_n, reset afifo in side; need set 1 after set reg_rst_afifo_out_n to 1;
19:15	R/W		reg_tdm_init_bitnum, initial count value of bitcnt
14:10	R/W		reg_tdm_init_slotnum, initial count value of slotcnt
9:5	R/W		reg_tdmout_slot_num , max value of slotcnt; if each frame has 8 slots, set it to 7;
4:0	R/W		reg_tdmout_bit_num ,max value of bitcnt; if each slot has 16bits, set it to 15;

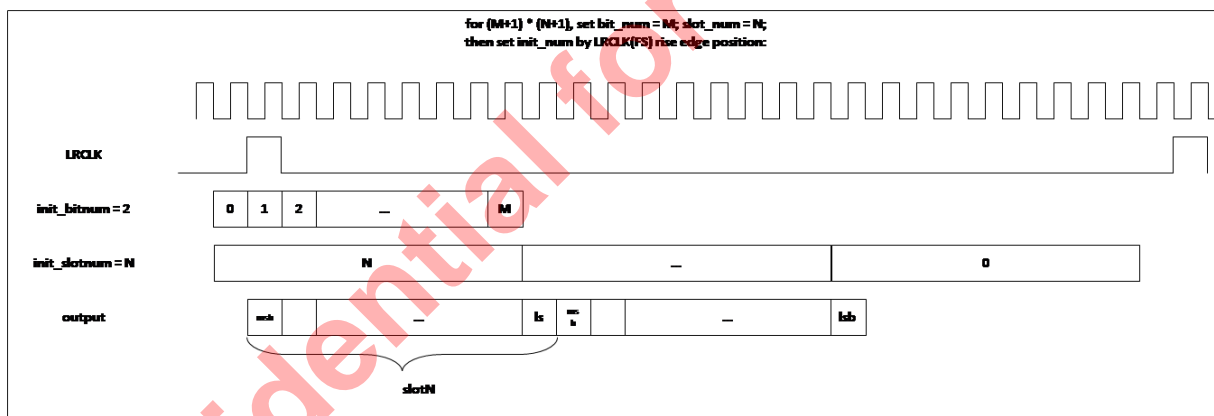
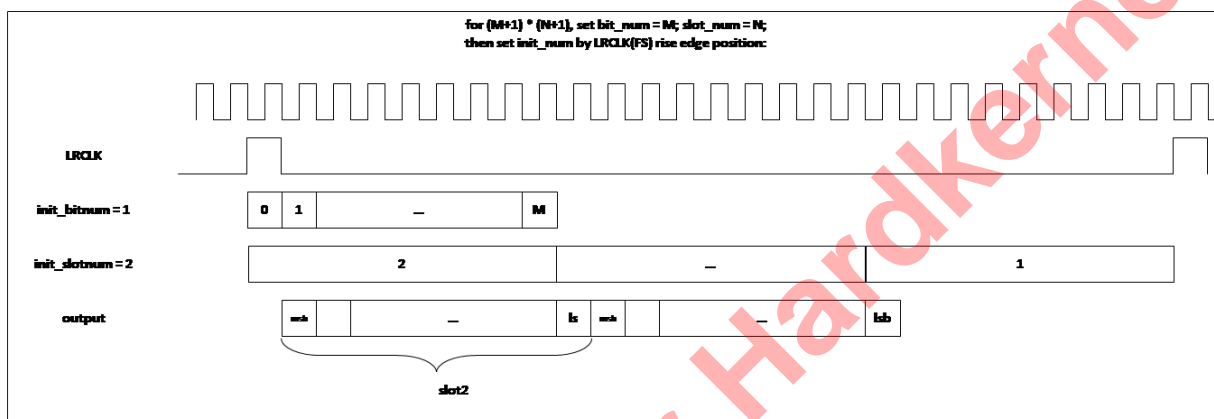
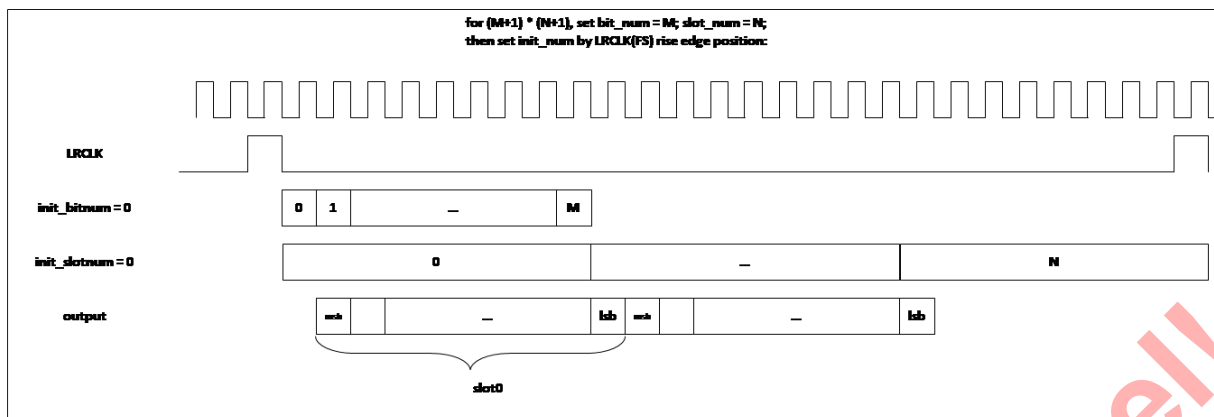

Table 10-82 EE\_AUDIO\_TDMOUT\_A\_CTRL1 0x141

Bits	R/W	Default	Description
31	R/W	0x0000-0000	eq_drc_sel; 1: select eq_drc output;
30	R/W		reg_debug_en,0:disable debug feature; 1: enable;
29	R/W		reg_out_lsb_first, 0: msb first; 1: lsb first;
28	R/W		reg_rev_ws_in, revert ws; 0: disable; 1: enable;
27	R/W		reg_rev_dat, revert data; 0: disable; 1: enable;
26:24	R/W		reg_frddr_sel, 0:frddr_A;1:frddr_B;2:frddr_C;
23:16	R/W		reg_frddr_sel, 0:frddr_A;1:frddr_B;2:frddr_C; 3:frddr_D;4:frddr_E

Bits	R/W	Default	Description
15:14	R/W		reg_gain_shift; 0: data * 1; 1: data * 2; 2: data * 4; 3: data * 8;
12:8	R/W		reg_frddr_msb, msb position of data
7	R/W		reg_gain_en, 0:disable; 1: enable data * gain;
6:4	R/W		reg_frddr_type, 0: split 64bits ddr data to 8 sample, each sample need 8 bits; if bitwidth < 8, left-justified; 1: split 64bits ddr data to 4 sample, each sample need 16 bits; if bitwidth < 16, left-justified ; 2: split 64bits ddr data to 4 sample, each sample need 16 bits; if bitwidth < 16, right-justified ; 3: split 64bits ddr data to 2 sample, each sample need 32 bits; if bitwidth < 32, left-justified; 4: split 64bits ddr data to 2 sample, each sample need 32 bits; if bitwidth < 32, right-justified;

For position of sample in DDR:

ddr_data [7:0] (byte)									
type	byte7	byte6	byte5	byte4	byte3	byte2	byte1	byte0	
0	s7	s6	s5	s4	s3	s2	s1	s0	
	s15	s14	s13	s12	s11	s10	s9	s8	
1/2	s3		s2		s1		s0		
	s7		s6		s5		s4		
3/4	s1			s0					
	s3			s2					

For encoder, it will start output[31] first, then output[30], finished at output[32-bit\_num]; If lsb\_first, will start s[0], then s[1], finished at s[bit\_num+1];

output [31:0] (bit)																																						
type	31	30	29	28	27	26	25	24	23	22	21	20	19	18	17	16	15	14	13	12	11	10	9	8	7	6	5	4	3	2	1	0						
0	s[7]	s[6]	s[5]	s[4]	s[3]	s[2]	s[1]	s[0]	0																													
1	s[15]	s[14]	s[13]	s[12]	s[11]	s[10]	s[9]	s[8]	s[7]	s[6]	s[5]	s[4]	s[3]	s[2]	s[1]	s[0]	0										0											
2	s[msb]	s[msb-1]	...		s[1]	s[0]	0																															
3	s[31]	s[30]	s[29]	s[28]	s[27]	s[26]	s[25]	s[24]	s[23]	s[22]	s[21]	s[20]	s[19]	s[18]	s[17]	s[16]	s[15]	s[14]	s[13]	s[12]	s[11]	s[10]	s[9]	s[8]	s[7]	s[6]	s[5]	s[4]	s[3]	s[2]	s[1]	s[0]						
4	s[msb]	s[msb-1]	...																		s[1]	s[0]	0															

Table 10-83 EE\_AUDIO\_TDMOUT\_A\_CTRL2 0x2a0

Bits	R/W	Default	Description
31:24	R/W	0x00000000	reserved
23:16	R/W		force_oe_val[7:0];



Bits	R/W	Default	Description
15:8	R/W		force_oe[7:0]; 1: oe = force_val; 0: oe = mask_val;
7:0	R/W		reg_tdm_lr_mix, [7]: mix l7 and r7; [6]: mix l6 and r6; [5]: mix l5 and r5; [4]: mix l4 and r4; [3]: mix l3 and r3; [2]: mix l2 and r2; [1]: mix l1 and r1; [0]: mix l0 and r0;

Table 10-84 EE\_AUDIO\_TDMOUT\_A\_SWAP0 0x142

Bits	R/W	Default	Description
31:28	R/W	0x00000000	ch7_sel 0: lane0 left channel; 1: lane0 right channel; 2: lane1 left channel; 3: lane1 right channel; 4: lane2 left channel; 5: lane2 right channel; 6: lane3 left channel; 7: lane3 right channel; 8: lane4 left channel; 9: lane4 right channel; 10: lane5 left channel; 11: lane5 right channel; 12: lane6 left channel; 13: lane6 right channel; 14: lane7 left channel; 15: lane7 right channel;
27:24	R/W		ch6_sel
23:20	R/W		ch5_sel
19:16	R/W		ch4_sel
15:12	R/W		ch3_sel
11:8	R/W		ch2_sel
7:4	R/W		ch1_sel
3:0	R/W		ch0_sel

Table 10-85 EE\_AUDIO\_TDMOUT\_A\_SWAP1 0x2a1

Bits	R/W	Default	Description
31:28	R/W	0x00000000	ch15_sel
27:24	R/W		ch14_sel
23:20	R/W		ch13_sel
19:16	R/W		ch12_sel
15:12	R/W		ch11_sel
11:8	R/W		ch10_sel

Bits	R/W	Default	Description
7:4	R/W		ch9_sel
3:0	R/W		ch8_sel

Table 10-86 EE\_AUDIO\_TDMOUT\_A\_MASK0 0x143

Bits	R/W	Default	Description
31:0	R/W	0x0000-0000	reg_lane0_mask, mask each channel in lane0, max is 32 ch;

Table 10-87 EE\_AUDIO\_TDMOUT\_A\_MASK1 0x144

Bits	R/W	Default	Description
31:0	R/W	0x0000-0000	reg_lane1_mask, mask each channel in lane1, max is 32 ch;

Table 10-88 EE\_AUDIO\_TDMOUT\_A\_MASK2 0x145

Bits	R/W	Default	Description
31:0	R/W	0x0000-0000	reg_lane2_mask, mask each channel in lane2, max is 32 ch;

Table 10-89 EE\_AUDIO\_TDMOUT\_A\_MASK3 0x146

Bits	R/W	Default	Description
31:0	R/W	0x0000-0000	reg_lane3_mask, mask each channel in lane3, max is 32 ch;

Table 10-90 EE\_AUDIO\_TDMOUT\_A\_MASK4 0x2a4

Bits	R/W	Default	Description
31:0	R/W	0x00000000	reg_lane4_mask, mask each channel in lane4, max is 32 ch;

Table 10-91 EE\_AUDIO\_TDMOUT\_A\_MASK5 0x2a5

Bits	R/W	Default	Description
31:0	R/W	0x00000000	reg_lane5_mask, mask each channel in lane5, max is 32 ch;

Table 10-92 EE\_AUDIO\_TDMOUT\_A\_MASK6 0x2a6

Bits	R/W	Default	Description
31:0	R/W	0x00000000	reg_lane6_mask, mask each channel in lane6, max is 32 ch;

Table 10-93 EE\_AUDIO\_TDMOUT\_A\_MASK7 0x2a7

Bits	R/W	Default	Description
31:0	R/W	0x00000000	reg_lane7_mask, mask each channel in lane7, max is 32 ch;

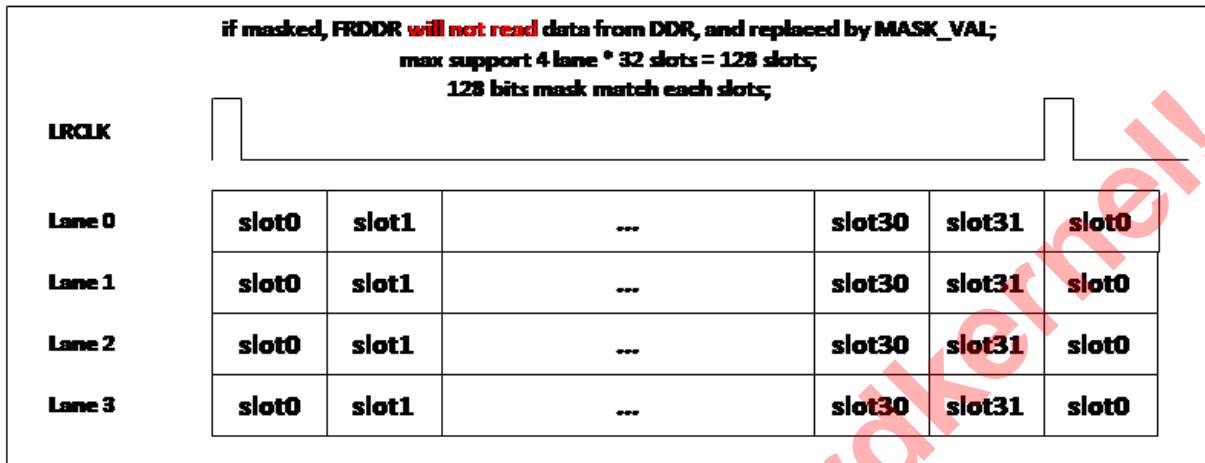

Table 10-94 EE\_AUDIO\_TDMOUT\_A\_STAT 0x147

Bits	R/W	Default	Description
31:29	R/W	0x0000-0000	fifo_cnt, afifo cnt
28	R/W		up_error, change to 1 if overflow
27:24	R/W		req_frdd_fsm_stat
21	R/W		r_slot_cnt_err
20	R/W		r_bit_cnt_err
16:12	R/W		r_max_slot_cnt
8:4	R/W		r_max_bit_cnt
3	R/W		r_out_en
2	R/W		r_out_en_pre
1	R/W		r_first_fs
0	R/W		c_frdd_init_finish

Table 10-95 EE\_AUDIO\_TDMOUT\_A\_GAIN0 0x148

Bits	R/W	Default	Description
31:24	R/W	0x0000-0000	gain_ch3
23:16	R/W		gain_ch2
15:8	R/W		gain_ch1
7:0	R/W		gain_ch0

**Table 10-96 EE\_AUDIO\_TDMOUT\_A\_GAIN1 0x149**

Bits	R/W	Default	Description
31:24	R/W	0x0000-0000	gain_ch7
23:16	R/W		gain_ch6
15:8	R/W		gain_ch5
7:0	R/W		gain_ch4

**Table 10-97 EE\_AUDIO\_TDMOUT\_A\_GAIN2 0x2a2**

Bits	R/W	Default	Description
31:24	R/W	0x00000000	gain_ch11
23:16	R/W		gain_ch10
15:8	R/W		gain_ch9
7:0	R/W		gain_ch8

**Table 10-98 EE\_AUDIO\_TDMOUT\_A\_GAIN3 0x2a3**

Bits	R/W	Default	Description
31:24	R/W	0x00000000	gain_ch15
23:16	R/W		gain_ch14
15:8	R/W		gain_ch13
7:0	R/W		gain_ch12

**Table 10-99 EE\_AUDIO\_TDMOUT\_A\_MUTE\_VAL 0x14a**

Bits	R/W	Default	Description
31:0	R/W	0x0000-0000	reg_tmdin_a_mute_val, when mute , the channel value

**Table 10-100 EE\_AUDIO\_TDMOUT\_A\_MUTE0 0x14b**

Bits	R/W	Default	Description
31:0	R/W	0x0000-0000	reg_lane0_mute, mute each channel in lane0, max is 32 ch;

**Table 10-101 EE\_AUDIO\_TDMOUT\_A\_MUTE1 0x14c**

Bits	R/W	Default	Description
31:0	R/W	0x0000-0000	reg_lane1_mute, mute each channel in lane1, max is 32 ch;

**Table 10-102 EE\_AUDIO\_TDMOUT\_A\_MUTE2 0x14d**

Bits	R/W	Default	Description
31:0	R/W	0x0000-0000	reg_lane2_mute, mute each channel in lane2 max is 32 ch;

**Table 10-103 EE\_AUDIO\_TDMOUT\_A\_MUTE3 0x14e**

Bits	R/W	Default	Description
31:0	R/W	0x0000-0000	reg_lane3_mute, mute each channel in lane3, max is 32 ch;

**Table 10-104 EE\_AUDIO\_TDMOUT\_A\_MUTE4 0x2a8**

Bits	R/W	Default	Description
31:0	R/W	0x00000000	reg_lane4_mute, mute each channel in lane4, max is 32 ch;

**Table 10-105 EE\_AUDIO\_TDMOUT\_A\_MUTE5 0x2a9**

Bits	R/W	Default	Description
31:0	R/W	0x00000000	reg_lane5_mute, mute each channel in lane5, max is 32 ch;

**Table 10-106 EE\_AUDIO\_TDMOUT\_A\_MUTE6 0x2aa**

Bits	R/W	Default	Description
31:0	R/W	0x00000000	reg_lane6_mute, mute each channel in lane6 max is 32 ch;

**Table 10-107 EE\_AUDIO\_TDMOUT\_A\_MUTE7 0x2ab**

Bits	R/W	Default	Description
31:0	R/W	0x00000000	reg_lane7_mute, mute each channel in lane7, max is 32 ch;

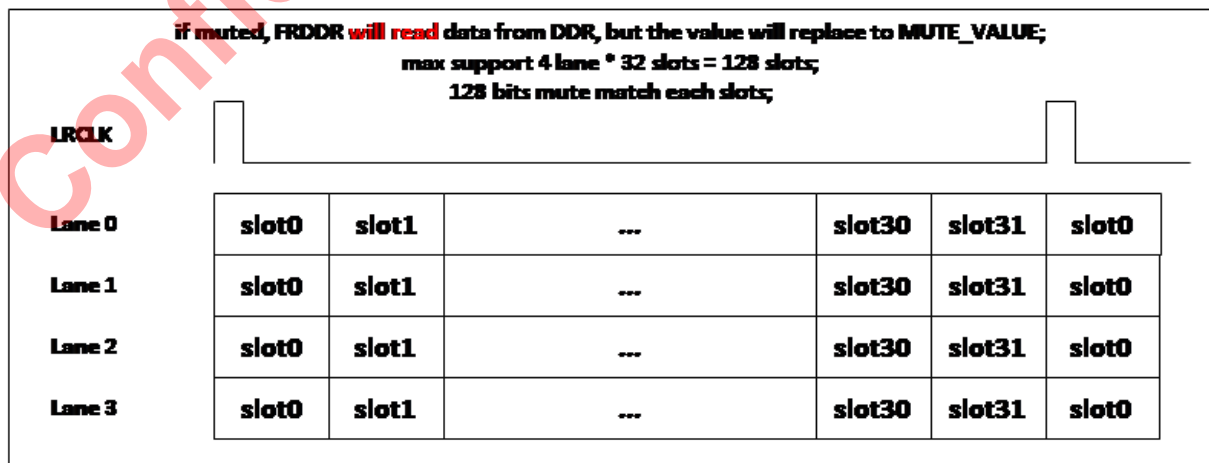

Table 10-108 EE\_AUDIO\_TDMOUT\_A\_MASK\_VAL 0x14f

Bits	R/W	Default	Description
31:0	R/W	0x0000-0000	reg_tdmout_mask_val, when masked, the channel value

EE_AUDIO_TDMOUT_B_CTRL0	0x150
EE_AUDIO_TDMOUT_B_CTRL1	0x151
EE_AUDIO_TDMOUT_B_CTRL2	0x2b0
EE_AUDIO_TDMOUT_B_SWAP0	0x152
EE_AUDIO_TDMOUT_B_SWAP1	0x2b1
EE_AUDIO_TDMOUT_B_MASK0	0x153
EE_AUDIO_TDMOUT_B_MASK1	0x154
EE_AUDIO_TDMOUT_B_MASK2	0x155
EE_AUDIO_TDMOUT_B_MASK3	0x156
EE_AUDIO_TDMOUT_B_MASK4	0x2b4
EE_AUDIO_TDMOUT_B_MASK5	0x2b5
EE_AUDIO_TDMOUT_B_MASK6	0x2b6
EE_AUDIO_TDMOUT_B_MASK7	0x2b7
EE_AUDIO_TDMOUT_B_STAT	0x157
EE_AUDIO_TDMOUT_B_GAIN0	0x158
EE_AUDIO_TDMOUT_B_GAIN1	0x159
EE_AUDIO_TDMOUT_B_GAIN2	0x2b2
EE_AUDIO_TDMOUT_B_GAIN3	0x2b3
EE_AUDIO_TDMOUT_B_MUTE_VAL	0x15a
EE_AUDIO_TDMOUT_B_MUTE0	0x15b
EE_AUDIO_TDMOUT_B_MUTE1	0x15c
EE_AUDIO_TDMOUT_B_MUTE2	0x15d
EE_AUDIO_TDMOUT_B_MUTE3	0x15e
EE_AUDIO_TDMOUT_B_MUTE4	0x2b8
EE_AUDIO_TDMOUT_B_MUTE5	0x2b9
EE_AUDIO_TDMOUT_B_MUTE6	0x2ba
EE_AUDIO_TDMOUT_B_MUTE7	0x2bb
EE_AUDIO_TDMOUT_B_MASK_VAL	0x15f
EE_AUDIO_TDMOUT_C_CTRL0	0x160
EE_AUDIO_TDMOUT_C_CTRL1	0x161
EE_AUDIO_TDMOUT_C_CTRL2	0x2c0
EE_AUDIO_TDMOUT_C_SWAP0	0x162

EE_AUDIO_TDMOUT_C_SWAP1	0x2c1
EE_AUDIO_TDMOUT_C_MASK0	0x163
EE_AUDIO_TDMOUT_C_MASK1	0x164
EE_AUDIO_TDMOUT_C_MASK2	0x165
EE_AUDIO_TDMOUT_C_MASK3	0x166
EE_AUDIO_TDMOUT_C_MASK4	0x2b4
EE_AUDIO_TDMOUT_C_MASK5	0x2b5
EE_AUDIO_TDMOUT_C_MASK6	0x2b6
EE_AUDIO_TDMOUT_C_MASK7	0x2b7
EE_AUDIO_TDMOUT_C_STAT	0x167
EE_AUDIO_TDMOUT_C_GAIN0	0x168
EE_AUDIO_TDMOUT_C_GAIN1	0x169
EE_AUDIO_TDMOUT_C_GAIN2	0x2c2
EE_AUDIO_TDMOUT_C_GAIN3	0x2c3
EE_AUDIO_TDMOUT_C_MUTE_VAL	0x16a
EE_AUDIO_TDMOUT_C_MUTE0	0x16b
EE_AUDIO_TDMOUT_C_MUTE1	0x16c
EE_AUDIO_TDMOUT_C_MUTE2	0x16d
EE_AUDIO_TDMOUT_C_MUTE3	0x16e
EE_AUDIO_TDMOUT_C_MUTE4	0x2c8
EE_AUDIO_TDMOUT_C_MUTE5	0x2c9
EE_AUDIO_TDMOUT_C_MUTE6	0x2ca
EE_AUDIO_TDMOUT_C_MUTE7	0x2cb
EE_AUDIO_TDMOUT_C_MASK_VAL	0x16f

### 10.11.7 TORAM Registers

Table 10-109 EE\_AUDIO\_TORAM\_CTRL0 0x1c0

Bits	R/W	Default	Description
31	R/W	0x0000-0000	reg_toddr_en, 0: disable; 1: enable;
30	R/W		Reserved ;
29	R/W		reg_ext_signed, 0: select write to only one buff (start_addr,finish_addr);
28	R/W		Reserved ;
27	R/W		Enable_sync_chnum;1: start store data when first ch ;
26:24	R/W		Reserved ;
23:16	R/W		[23:18] : reserved; [17] : when write to ddr address match "int_addr"; [16]: when write to ddr address match "finish_addr";

Bits	R/W	Default	Description
15:13	R/W		reg_toddr_sel, 0: combined data[m:n] without gap; like S0[m:n],S1[m:n],S2[m:n],... 1: combined data[m:n] as 16bits; like {S0[11:0],4'd0},{S1[11:0],4'd0}... 2: combined data[m:n] as 16bits; like {4'd0,S0[11:0]},{4'd0,{S1[11:0]}... 3: combined data[m:n] as 32bits; like {S0[27:4],8'd0},{S1[27:4],8'd0}... 4: combined data[m:n] as 32bits; like {8'd0,S0[27:4]},{8'd0,{S1[27:4]}...
12:8	R/W		reg_toddr_m_sel, the msb position in data
7:3	R/W		reg_toddr_n_sel, the lsb position in data

Table 10-110 EE\_AUDIO\_TORAM\_CTRL1 0x1c1

Bits	R/W	Default	Description
31:28	R/W	0x0000-0000	reg_toram_src_sel, [15]:vad_q; [11]:earc_rx; [10]:spdifin_lb; [9]:loopback_b; [7]: loopback; [6]: tdmin_lb; [4]: pdmin; [3]: spdifin; [2]: tdmin_c; [1]: tdmin_b; [0]: tdmin_a;
24	R/W		Insert_chnum;0: disable; 1: insert chnum[9:0] to data[9:0]
23:16	R/W		Reserved ;
11:8	R/W		reg_status_sel, control status2 source;
7:0	R/W		reg_int_status_clr,clear each bits of int_status register

Table 10-111 EE\_AUDIO\_TORAM\_START\_ADDR 0x1c2

Bits	R/W	Default	Description
31:0	R/W	0x0000-0000	start_addr, buff_A start address, ignore [2:0]

Table 10-112 EE\_AUDIO\_TORAM\_FINISH\_ADDR 0x1c3

Bits	R/W	Default	Description
31:0	R/W	0x0000-0000	finish_addr, buff_A finish address, ignore [2:0]

Table 10-113 EE\_AUDIO\_TORAM\_INT\_ADDR 0x1c4

Bits	R/W	Default	Description
31:0	R/W	0x0000-0000	int_addr, usage A : as an address of interrupt;



Table 10-114 EE\_AUDIO\_TORAM\_STATUS1 0x1c5

Bits	R/W	Default	Description
7:0	R/W	0x0000-0000	int_status, when irq generate, related bit will changed to 1 and can only clear by reg_int_status_clr

Table 10-115 EE\_AUDIO\_TORAM\_STATUS2 0x1c6

Bits	R/W	Default	Description
31:0	R/W	0x0000-0000	status2, by reg_status_sel: 0: current write ram times; 1: current write ram address;

Table 10-116 EE\_AUDIO\_TORAM\_INIT\_ADDR 0x1c7

Bits	R/W	Default	Description
31:0	R/W	0x0000-0000	first RAM address after enable set to 1;

### 10.11.8 SPDIF Registers

Table 10-117 EE\_AUDIO\_SPDIFIN\_CTRL0 0x100

Bits	R/W	Default	Description
31	R/W	0x0000-0000	reg_work_enable, 0: disable; 1:enable;
30	R/W		reg_chnum_sel, 0: ch_num = 0~383(include frame cnt); 1: ch_num = 0~1(only L/R);
29	R/W		reg_rst_afifo_out_n, reset afifo out side;
28	R/W		reg_rst_afifo_in_n, reset afifo in side; need set 1 after set reg_rst_afifo_out_n to 1;
27	R/W		reg_debug_en, 0:disable debug; 1: enable;
26	R/W		reg_chunm_en; 1: start add ch_cnt to ch_num;
25	R/W		reg_findpapb_en, 0: disable NonPCM mode; 1: enable;
24	R/W		reg_width_sel, 0: detect sample mode by max_width;1: detect sample mode by min_width;
23:12	R/W		reg_nonpcm2pcm_th, when detected NonPcm mode;if long time (z_cnt >= th) didn't detect PaPb again, will generate interrupt to SW: now changed to PCM mode;
11:8	R/W		reg_ch_status_sel, For EE_AUDIO_SPDIFIN_STAT1
7	R/W		reg_mute_l, 0: disable ; 1: mute channel L;
6	R/W		reg_mute_r, 0: disable ; 1: mute channel R;
5:4	R/W		reg_spdifin_src_sel, 0: PAD of spdifin;1: spdifout;
3	R/W		reg_check_valid, 0: disable valid check ; 1: enable;
2	R/W		reg_check_parity, 0: disable parity check ; 1: enable;

Bits	R/W	Default	Description
1	R/W		reg_invert_data, 0: disalbe; 1: invert [27:4] to [4:27];
0	R/W		reg_spdifin_phase, 0: disable invert; 1: enable;

Table 10-118 EE\_AUDIO\_SPDIFIN\_CTRL1 0x101

Bits	R/W	Default	Description
31	R/W	0x0000-0000	reg_force_sample_mode, 0: auto detect sample mode; 1: force a fixed sample mode;
30:28	R/W		reg_sample_mode
27:20	R/W		reg_interrupt_mask, mask each interrupt;
19:0	R/W		reg_base_timer, define a base timer to detect sample mode changed;

Table 10-119 EE\_AUDIO\_SPDIFIN\_CTRL2 0x102

Bits	R/W	Default	Description
29:20	R/W	0x0000-0000	reg_sample_mode0_timer_th
19:10	R/W		reg_sample_mode1_timer_th
9:0	R/W		reg_sample_mode2_timer_th

Table 10-120 EE\_AUDIO\_SPDIFIN\_CTRL3 0x103

Bits	R/W	Default	Description
29:20	R/W	0x0000-0000	reg_sample_mode3_timer_th
19:10	R/W		reg_sample_mode4_timer_th
9:0	R/W		reg_sample_mode5_timer_th

Table 10-121 EE\_AUDIO\_SPDIFIN\_CTRL4 0x104

Bits	R/W	Default	Description
31:24	R/W	0x0000-0000	reg_sample_mode0_timer
23:16	R/W		reg_sample_mode1_timer
15:8	R/W		reg_sample_mode2_timer
7:0	R/W		reg_sample_mode3_timer

**Table 10-122 EE\_AUDIO\_SPDIFIN\_CTRL5 0x105**

Bits	R/W	Default	Description
31:24	R/W	0x0000-0000	reg_sample_mode4_timer
23:16	R/W		reg_sample_mode5_timer
15:8	R/W		reg_sample_mode6_timer

We need automatically detect the frequency of sample rate (FS). It will done by search min\_period or max\_period of SPDIF IN and compared to thresholds. We can support 7 mode settings.

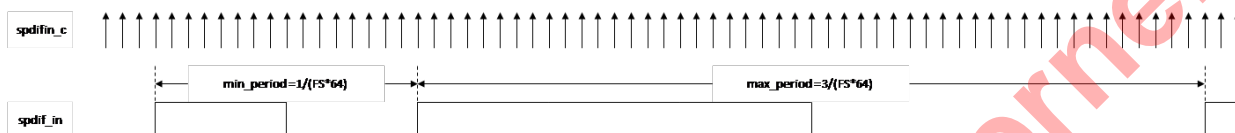

For example: If spdifin\_clk is 166MHz, and we want support 48KHz and 96KHz.

The min\_period of 48KHz is  $1/(48000*64)$  and the counter number by 166MHz is  $166000000/(48000*64) = 54$ ;

96KHz counter number is  $166000000/(96000*64) = 27$ ;

Then set:

Width\_sel = 1;

Mode0\_th =  $(54+27)/2 = 41$ ;

Mode1\_th = 0;

Mode0\_timer = 27;

Mode1\_timer = 13;

Or:

Width\_sel = 0;

Mode0\_th =  $(162+81)/2 = 121$ ;

Mode1\_th = 0;

Mode0\_timer = 27;

Mode1\_timer = 13;

More example:

spdifin_clk = 166MHz								
			width_sel = 1			width_sel = 0		
	FS(Hz)	timer	min_period			max_period		
mode0	24000	54	108.0729-167	th0	95	324.2187-5	th0	283
mode1	32000	40	81.05468-75	th1	70	243.1640-625	th1	209

mode2	44100	29	58.81519-274	th2	58	176.4455-782	th2	172
mode3	46000	28	56.38586-957	th3	55	169.1576-087	th3	165
mode4	48000	27	54.03645-833	th4	41	162.1093-75	th4	121
mode5	96000	13	27.01822-917	th5	20	81.05468-75	th5	60
mode6	192000	6	13.50911-458			40.52734-375		

spdifin_clk = 250MHz								
			width_sel = 1			width_sel = 0		
	FS(Hz)	timer	min_period			max_period		
mode0	24000	81	162.7604-167	th0	142	488.2812-5	th0	427
mode1	32000	61	122.0703-125	th1	105	366.2109-375	th1	315
mode2	44100	44	88.57709-751	th2	87	265.7312-925	th2	260
mode3	46000	42	84.91847-826	th3	83	254.7554-348	th3	249
mode4	48000	40	81.38020-833	th4	61	244.1406-25	th4	183
mode5	96000	20	40.69010-417	th5	31	122.0703-125	th5	91
mode6	192000	10	20.34505-208			61.03515-625		

spdifin_clk = 400MHz								
			width_sel = 1			width_sel = 0		
	FS(Hz)	timer	min_period			max_period		
mode0	24000	130	260.4166-667	th0	228	781.25	th0	683
mode1	32000	97	195.3125	th1	169	585.9375	th1	505
mode2	44100	70	141.7233-56	th2	139	425.1700-68	th2	416
mode3	46000	67	135.8695-652	th3	133	407.6086-957	th3	399
mode4	48000	65	130.2083-333	th4	98	390.625	th4	292
mode5	96000	32	65.10416-667	th5	49	195.3125	th5	146
mode6	192000	16	32.55208-333			97.65625		

Table 10-123 EE\_AUDIO\_SPDIFIN\_CTRL6 0x106

Bits	R/W	Default	Description
31:24	R/W	0x0000-0000	Reg_clr_internal_sts[7:0]; 7: clear valid bit status; 6: clear parity bit status; 5: clear ch status; 4: clear z_cnt status; 3: clear find_nonpcm status; 2: clear pd_data status; 1: clear pc_data status; 0: clear find_papb status;
23:16	R/W		Reg_clr_interrupt[7:0] for each bit of irq_status[7:0];
14	R/W		enable send out find_z
8	R/W		reg_papb_ext_sync, 1: add ext "0" sync check for papb; 0: disable;
7:0	R/W		reg_papb_ext_mask, mask 8 channel "0" sync

Table 10-124 EE\_AUDIO\_SPDIFIN\_STAT0 0x107

Bits	R/W	Default	Description
31	R/W	0x0000-0000	Valid bit
30:28	R/W		r_sample_mode, current sample mode;
27:18	R/W		r_width_min, the min width of two edge;
17:8	R/W		r_width_max, the max width of two edge;
7:0	R/W		r_interrupt_status, interrupt status, need clear by reg_clk_interrupt; [7]: find PaPb; [6]: valid changed; [5]: find nonpcm to pcm ( reg_nonpcm2pcm_th ); [4]: find Pc or Pd changed; [3]: find CH status changed; [2]: find sample mode changed; [1]: find parity error; [0]: find overflow;

Table 10-125 EE\_AUDIO\_SPDIFIN\_STAT1 0x108

Bits	R/W	Default	Description
31:0	R/W	0x0000-0000	channel status, by reg_ch_status_sel; reg_ch_status_sel[3]: 0: channel A; 1: channel B; reg_ch_status_sel[2:0]: 0: ch_status[31:0]; 1: ch_status[63:32]; 2: ch_status[95:64]; 3: ch_status[127:96]; 4: ch_status[159:128]; 5: ch_status[191:160]; 6: pc[15:0],pd[15:0];

Table 10-126 EE\_AUDIO\_SPDIFIN\_STAT2 0x109

Bits	R/W	Default	Description
31:0	R/W	0x0000-0000	debug status, by reg_ch_status_sel; 0: r_z_width, the width of two preamble Z; 1: {16'd0, frame_cnt_min[7:0], frame_cnt_max[7:0]}; 2: {6'd0, width_min[9:0], 6'd0, width_max[9:0]};

Table 10-127 EE\_AUDIO\_SPDIFIN\_MUTE\_VAL 0x10a

Bits	R/W	Default	Description
31:0	R/W	0x0000-0000	reg_spdifin_mute_val, when muted, the channel value

Table 10-128 EE\_AUDIO\_SPDIFOUT\_STAT 0x120

Bits	R/W	Default	Description
7:5	R/W	0x0000-0000	fifo_cnt, afifo cnt
4	R/W		up_error, change to 1 if overflow
3:0	R/W		req_frdd_fsm_stat

Table 10-129 EE\_AUDIO\_SPDIFOUT\_GAIN0 0x121

Bits	R/W	Default	Description
31:24	R/W	0x0000-0000	gain_ch3
23:16	R/W		gain_ch2
15:8	R/W		gain_ch1
7:0	R/W		gain_ch0

Table 10-130 EE\_AUDIO\_SPDIFOUT\_GAIN1 0x122

Bits	R/W	Default	Description
31:24	R/W	0x0000-0000	gain_ch7
23:16	R/W		gain_ch6
15:8	R/W		gain_ch5
7:0	R/W		gain_ch4

Table 10-131 EE\_AUDIO\_SPDIFOUT\_CTRL0 0x123

Bits	R/W	Default	Description
31	R/W	0x0000-0000	reg_work_enable, 0: disable ; 1: enable;
29	R/W		reg_rst_afifo_out_n, reset afifo out side;
28	R/W		reg_rst_afifo_in_n, reset afifo in side; need set 1 after set reg_rst_afifo_out_n to 1;
27	R/W		reg_hold_start_en; 1: add delay to match TDM out when share buff;
26	R/W		reg_userdata_sel, 0: "user data" = reg_userdata_set; 1: "user data" = data [29];
25	R/W		reg_userdata_set
24	R/W		reg_chdata_sel, 0: "ch status" = reg_chsts0~B ;1: "ch status" = data [30];
23	R/W		reg_mix_lr, 0: disable; 1: L = (L+R)/2; R = (L+R)/2;
22	R/W		reg_mute_l, 0: disable; 1: ch_l_data = reg_mute_val;
21	R/W		reg_mute_r, 0: disable; 1: ch_r_data = reg_mute_val;
20	R/W		reg_data_sel, 0: insert data from 31bits;1: insert data from 27bits;
19	R/W		reg_out_msb_first, 0: lsb first; 1: msb first;
18	R/W		reg_valid_sel, 0: "valid flag" = reg_valid_set; 1: "valid flag" = data [28];
17	R/W		reg_valid_set
11:4	R/W		reg_mask, [11:10]: mask lane3 L/R; [9:8]: mask lane2 L/R; [7:6]: mask lane1 L/R; [5:4]: mask lane0 L/R;
3:0	R/W		reg_parity_mask, [0]: initial parity value;

Table 10-132 EE\_AUDIO\_SPDIFOUT\_CTRL1 0x124

Bits	R/W	Default	Description
21	R/W	0x00000000	eq_drc_sel; 1: select eq_drc data;
27	R/W		reg_gain_en, 0:disable; 1: enable data * gain;
26:24	R/W		reg_frddr_sel, 0:frddr_A; 1:frddr_B; 2:frddr_C; 3:frddr_D; 4:frddr_E;
23:16	R/W		reg_wait_cnt, wait some time when enable set to 1; then start request data from frddr;
15:14	R/W		reg_gain_shift; 0: data * 1; 1: data * 2; 2: data * 4; 3: data * 8;
12:8	R/W		reg_frddr_msb, msb position of data

Bits	R/W	Default	Description
7	R/W		Reg_force_start; 1: needn't ack from FRDDR; for only transmit "ch status" usage.
6:4	R/W		reg_frddr_type, 0: split 64bits ddr data to 8 sample, each sample need 8 bits; if bitwidth < 8, left-justified; 1: split 64bits ddr data to 4 sample, each sample need 16 bits; if bitwidth < 16, left-justified ; 2: split 64bits ddr data to 4 sample, each sample need 16 bits; if bitwidth < 16, right-justified ; 3: split 64bits ddr data to 2 sample, each sample need 32 bits; if bitwidth < 32, left-justified; 4: split 64bits ddr data to 2 sample, each sample need 32 bits; if bitwidth < 32, right-justified;

Table 10-133 EE\_AUDIO\_SPDIFOUT\_PREAMB 0x125

Bits	R/W	Default	Description
31	R/W	0x0000-0000	set preamble Z, 0: preamble Z = 8'b11101000; 1: reg[7:0];
20	R/W		set preamble Y, 0: preamble Z = 8'b11100100; 1: reg[15:8];
29	R/W		set preamble X, 0: preamble Z = 8'b11100010; 1: reg[23:16];
23:16	R/W		preamble X
15:8	R/W		preamble Y
7:0	R/W		preamble Z

Table 10-134 EE\_AUDIO\_SPDIFOUT\_SWAP 0x126

Bits	R/W	Default	Description
31:16	R/W	0x0000-0000	hold start cnt, work when CTRL0[27] = 1;
6:4	R/W		lane0 right ch sel, 0: ch0; 1: ch1; 2: ch2; 3: ch3; 4: ch4; 5: ch5; 6: ch6; 7: ch7;
2:0	R/W		lane0 left ch sel, 0: ch0; 1: ch1; 2: ch2; 3: ch3; 4: ch4; 5: ch5; 6: ch6; 7: ch7;

Table 10-135 EE\_AUDIO\_SPDIFOUT\_CHSTS0 0x127

Bits	R/W	Default	Description
31:0	R/W	0x0000-0000	channel A status[31:0]



**Table 10-136 EE\_AUDIO\_SPDIFOUT\_CHSTS1 0x128**

Bits	R/W	Default	Description
31:0	R/W	0x0000-0000	channel A status[63:32]

**Table 10-137 EE\_AUDIO\_SPDIFOUT\_CHSTS2 0x129**

Bits	R/W	Default	Description
31:0	R/W	0x0000-0000	channel A status[95:64]

**Table 10-138 EE\_AUDIO\_SPDIFOUT\_CHSTS3 0x12a**

Bits	R/W	Default	Description
31:0	R/W	0x0000-0000	channel A status[127:96]

**Table 10-139 EE\_AUDIO\_SPDIFOUT\_CHSTS4 0x12b**

Bits	R/W	Default	Description
31:0	R/W	0x0000-0000	channel A status[159:128]

**Table 10-140 EE\_AUDIO\_SPDIFOUT\_CHSTS5 0x12c**

Bits	R/W	Default	Description
31:0	R/W	0x0000-0000	channel A status[191:160]

**Table 10-141 EE\_AUDIO\_SPDIFOUT\_CHSTS6 0x12d**

Bits	R/W	Default	Description
31:0	R/W	0x0000-0000	channel B status[31:0]

**Table 10-142 EE\_AUDIO\_SPDIFOUT\_CHSTS7 0x12e**

Bits	R/W	Default	Description
31:0	R/W	0x0000-0000	channel B status[63:32]

**Table 10-143 EE\_AUDIO\_SPDIFOUT\_CHSTS8 0x12f**

Bits	R/W	Default	Description
31:0	R/W	0x0000-0000	channel B status[95:64]

**Table 10-144 EE\_AUDIO\_SPDIFOUT\_CHSTS9 0x130**

Bits	R/W	Default	Description
31:0	R/W	0x0000-0000	channel B status[127:96]

**Table 10-145 EE\_AUDIO\_SPDIFOUT\_CHSTSA 0x131**

Bits	R/W	Default	Description
31:0	R/W	0x0000-0000	channel B status[159:128]

**Table 10-146 EE\_AUDIO\_SPDIFOUT\_CHSTSB 0x132**

Bits	R/W	Default	Description
31:0	R/W	0x0000-0000	channel B status[191:160]

EE\_AUDIO\_SPDIFOUT\_MUTE\_VAL 0x133  
 EE\_AUDIO\_SPDIFOUT\_B\_STAT 0x1a0  
 EE\_AUDIO\_SPDIFOUT\_B\_GAIN0 0x1a1  
 EE\_AUDIO\_SPDIFOUT\_B\_GAIN1 0x1a2  
 EE\_AUDIO\_SPDIFOUT\_B\_CTRL0 0x1a3  
 EE\_AUDIO\_SPDIFOUT\_B\_CTRL1 0x1a4  
 EE\_AUDIO\_SPDIFOUT\_B\_PREAMB 0x1a5  
 EE\_AUDIO\_SPDIFOUT\_B\_SWAP 0x1a6  
 EE\_AUDIO\_SPDIFOUT\_B\_CHSTS0 0x1a7  
 EE\_AUDIO\_SPDIFOUT\_B\_CHSTS1 0x1a8  
 EE\_AUDIO\_SPDIFOUT\_B\_CHSTS2 0x1a9  
 EE\_AUDIO\_SPDIFOUT\_B\_CHSTS3 0x1aa  
 EE\_AUDIO\_SPDIFOUT\_B\_CHSTS4 0x1ab  
 EE\_AUDIO\_SPDIFOUT\_B\_CHSTS5 0x1ac  
 EE\_AUDIO\_SPDIFOUT\_B\_CHSTS6 0x1ad  
 EE\_AUDIO\_SPDIFOUT\_B\_CHSTS7 0x1ae  
 EE\_AUDIO\_SPDIFOUT\_B\_CHSTS8 0x1af  
 EE\_AUDIO\_SPDIFOUT\_B\_CHSTS9 0x1b0  
 EE\_AUDIO\_SPDIFOUT\_B\_CHSTSA 0x1b1  
 EE\_AUDIO\_SPDIFOUT\_B\_CHSTSB 0x1b2  
 EE\_AUDIO\_SPDIFOUT\_B\_MUTE\_VAL 0x1b3

Table 10-147 EE\_AUDIO\_SPDIFIN\_LB\_CTRL0 0x1f0

Bits	R/W	Default	Description
31	R/W	0x0000-0000	reg_work_enable, 0: disable; 1:enable;
30	R/W		reg_chnum_sel, 0: ch_num = 0~383(include frame cnt); 1: ch_num = 0~1(only L/R);
29	R/W		reg_rst_afifo_out_n, reset afifo out side;
28	R/W		reg_rst_afifo_in_n, reset afifo in side; need set 1 after set reg_rst_afifo_out_n to 1;
26	R/W		reg_chunm_en; 1: start add ch_cnt to ch_num;
25	R/W		reg_findpapb_en, 0: disable NonPCM mode; 1: enable;
23:12	R/W		reg_nonpcm2pcm_th, when detected NonPcm mode;if long time (z_cnt >= th) didn't detect PaPb again, will generate interrupt to SW: now changed to PCM mode;
11:8	R/W		reg_ch_status_sel, For EE_AUDIO_SPDIFIN_STAT1
7	R/W		reg_mute_l, 0: disable ; 1: mute channel L;
6	R/W		reg_mute_r, 0: disable ; 1: mute channel R;
5:4	R/W		reg_spdifin_src_sel, 0: PAD of spdifin;1: spdifout;
3	R/W		reg_check_valid, 0: disable valid check ; 1: enable;
2	R/W		reg_check_parity, 0: disable parity check ; 1: enable;
1	R/W		reg_invert_data, 0: disable; 1:invert [27:4] to [4:27];
0	R/W		reg_spdifin_phase, 0: disable invert; 1: enable;

Table 10-148 EE\_AUDIO\_SPDIFIN\_LB\_CTRL1 0x1f1

Bits	R/W	Default	Description
27:20	R/W		reg_interrupt_mask, mask each interrupt;

Table 10-149 EE\_AUDIO\_SPDIFIN\_LB\_CTRL6 0x1f6

Bits	R/W	Default	Description
31:24	R/W	0x0000-0000	Reg_clr_internal_sts[7:0]; 7: clear valid bit status; 6: clear parity bit status; 5: clear ch status; 4: clear z_cnt status; 3: clear find_nonpcm status; 2: clear pd_data status; 1: clear pc_data status; 0: clear find_papb status;
23:16	R/W		Reg_clr_interrupt[7:0] for each bit of irq_status[7:0];
8	R/W		reg_papb_ext_sync, 1: add ext "0" sync check for papb; 0: disable;
7:0	R/W		reg_papb_ext_mask, mask 8 channel "0" sync

**Table 10-150 EE\_AUDIO\_SPDIFIN\_LB\_STAT0 0x1f7**

Bits	R/W	Default	Description
31	R/W	0x0000-0000	Valid bit
30:28	R/W		
27:18	R/W		
17:8	R/W		
7:0	R/W		r_interrupt_status, interrupt status, need clear by reg_clk_interrupt; [7]: find PaPb; [6]: valid changed; [5]: find nonpcm to pcm ( reg_nonpcm2pcm_th ) ; [4]: find Pc or Pd changed; [3]: find CH status changed; [1]: find parity error; [0]: find overflow;

**Table 10-151 EE\_AUDIO\_SPDIFIN\_LB\_STAT1 0x1f8**

Bits	R/W	Default	Description
31:0	R/W	0x0000-0000	channel status, by reg_ch_status_sel; reg_ch_status_sel[3]: 0: channel A; 1: channel B; reg_ch_status_sel[2:0]: 0: ch_status[31:0]; 1: ch_status[63:32]; 2: ch_status[95:64]; 3: ch_status[127:96]; 4: ch_status[159:128]; 5: ch_status[191:160]; 6: pc[15:0],pd[15:0];

**Table 10-152 EE\_AUDIO\_SPDIFIN\_LB\_MUTE\_VAL 0x1fa**

Bits	R/W	Default	Description
31:0	R/W	0x0000-0000	reg_spdifin_mute_val, when muted, the channel value

### 10.11.9 ResampleA Registers

Base Address: 0xFF661C00

Each register final address = module base address+ address \* 4

**Table 10-153 EE\_AED\_COEF\_RAM\_CNTL 0x0**

Bits	R/W	Default	Description
31-10	R/W	0x0	reserved;

### 10.11.10 ResampleB Registers

**Table 10-154 EE\_AUDIO\_RESAMPLEB\_CTRL0 0x1e0**

Bits	R/W	Default	Description
31	R/W	0x0000-0000	Soft_reset
28	R/W		Enable,
27:26	R/W		Method_sel,
25:16	R/W		outrdy_Cnt_ctrl[9:0],
15:0	R/W		Avg_cnt_init,

**Table 10-155 EE\_AUDIO\_RESAMPLEB\_CTRL1 0x1e1**

Bits	R/W	Default	Description
31:0	R/W	0x0000-0000	Phase_step, It is used to set the phase step of the accumulator. It is equal to $fs_{in}/fs_{out} * (1 << 28)$ .

**Table 10-156 EE\_AUDIO\_RESAMPLEB\_CTRL2 0x1e2**

Bits	R/W	Default	Description
30:28	R/W	0x0000-0000	outrdy_Cnt_ctrl[12:10],
27	R/W		resample_start_mode;
25	R/W		IIR filter enable
24	R/W		Pause_en
23:0	R/W		Pause_cnt_thd

**Table 10-157 EE\_AUDIO\_RESAMPLEB\_CTRL3 0x1e3**

Bits	R/W	Default	Description
18:16	R/W	0x0000-0000	Source sel; 0: toddr_A; 1: toddr_B; 2: toddr_C; 3: toddr_D; 4: loopback_A; 5: loopback_B;
14:12	R/W		resample_st_cnt;
11:8	R/W		Reg_ch_num_sel, The channel number of input
4:0	R/W		Reg_in_msb, the msb of input[31:0]

**Table 10-158 EE\_AUDIO\_RESAMPLEB\_COEF0 0x1e4**

Bits	R/W	Default	Description
25:0	R/W	0x8000-0000	IIR filter coef0

**Table 10-159 EE\_AUDIO\_RESAMPLEB\_COEF1 0x1e5**

Bits	R/W	Default	Description
25:0	R/W	0x0000-0000	IIR filter coef1

**Table 10-160 EE\_AUDIO\_RESAMPLEB\_COEF2 0x1e6**

Bits	R/W	Default	Description
25:0	R/W	0x0000-0000	IIR filter coef2

**Table 10-161 EE\_AUDIO\_RESAMPLEB\_COEF3 0x1e7**

Bits	R/W	Default	Description
25:0	R/W	0x0000-0000	IIR filter coef3

**Table 10-162 EE\_AUDIO\_RESAMPLEB\_COEF4 0x1e8**

Bits	R/W	Default	Description
25:0	R/W	0x0000-0000	IIR filter coef4

**Table 10-163 EE\_AUDIO\_RESAMPLEB\_STATUS1 0x1e9**

Bits	R/W	Default	Description
24	R/W	0x0000-0000	The pause status
21:0	R/W		The real frequency of input data

**Table 10-164 EE\_AUDIO\_TORAM\_CTRL1 0x1c1**

Bits	R/W	Default	Description
24	R/W	0x0000-0000	Insert_chnum; 0: disable; 1: insert chnum[9:0] to data[9:0]
23:16	R/W		Reserved ;
11:8	R/W		reg_status_sel, control status2 source;
7:0	R/W		reg_int_status_clr,clear each bits of int_status register

**Table 10-165 EE\_AUDIO\_TORAM\_START\_ADDR 0x1c2**

Bits	R/W	Default	Description
31:0	R/W	0x0000-0000	start_addr, buff_A start address, ignore [2:0]

**Table 10-166 EE\_AUDIO\_TORAM\_FINISH\_ADDR0x1c3**

Bits	R/W	Default	Description
31:0	R/W	0x0000-0000	finish_addr, buff_A finish address, ignore [2:0]

**Table 10-167 EE\_AUDIO\_TORAM\_INT\_ADDR 0x1c4**

Bits	R/W	Default	Description
31:0	R/W	0x0000-0000	int_addr, usage A: as an address of interrupt;

**Table 10-168 EE\_AUDIO\_TORAM\_STATUS1 0x1c5**

Bits	R/W	Default	Description
7:0	R/W	0x0000-0000	int_status, when irq generate, related bit will change to 1 and can only clear by reg_int_status_clr

**Table 10-169 EE\_AUDIO\_TORAM\_STATUS2 0x1c6**

Bits	R/W	Default	Description
31:0	R/W	0x0000-0000	status2, by reg_status_sel: 0: current write ram times;1: current write ram address;

**Table 10-170 EE\_AUDIO\_TORAM\_INIT\_ADDR 0x1c7**

Bits	R/W	Default	Description
31:0	R/W	0x0000-0000	first RAM address after enable set to 1;

### 10.11.11 TOACODEC Registers

**Table 10-171 EE\_AUDIO\_TOACODEC\_CTRL0 0x1d0**

Bits	R/W	Default	Description
31	R/W	0x0000-0000	reg_toacodec_en, 0: disable; 1: enable;
23:20	R/W		Dat1_sel: 0: tdmout_a_dat[0]; 1: tdmout_a_dat[1]; 2: tdmout_a_dat[2]; 3: tdmout_a_dat[3]; 4: tdmout_b_dat[0]; 5: tdmout_b_dat[1]; 6: tdmout_b_dat[2]; 7: tdmout_b_dat[3]; 8: tdmout_c_dat[0]; 9: tdmout_c_dat[1]; 10: tdmout_c_dat[2]; 11: tdmout_c_dat[3];

Bits	R/W	Default	Description
19:16	R/W		Dat0_sel: 0: tdmout_a_dat[0]; 1: tdmout_a_dat[1]; 2: tdmout_a_dat[2]; 3: tdmout_a_dat[3]; 4: tdmout_b_dat[0]; 5: tdmout_b_dat[1]; 6: tdmout_b_dat[2]; 7: tdmout_b_dat[3]; 8: tdmout_c_dat[0]; 9: tdmout_c_dat[1]; 10: tdmout_c_dat[2]; 11: tdmout_c_dat[3];
14:12	R/W		lrclk_sel: 0: tdmout_a_lrclk; 1: tdmout_b_lrclk; 2: tdmout_c_lrclk; 4: tadmin_a_lrclk; 5: tadmin_b_lrclk; 6: tadmin_c_lrclk;
10	R/W		Lrclk_inv; 1: invert lrclk;
9	R/W		Bclk_cap_inv: The dat_o and lrclk_o will captured for timing balance after select; If this bit set to 1, will use invert bclk to capture;
8	R/W		Bclk_o_inv: if set 1, the final bclk connect to acodec will invert;
6:4	R/W		Bclk_sel: 0: tdmout_a_bclk; 1: tdmout_b_bclk; 2: tdmout_c_bclk; 4: tadmin_a_bclk; 5: tadmin_b_bclk; 6: tadmin_c_bclk;
2:0	R/W		Mclk_sel: 0:mst_mclk_a; 1:mst_mclk_b; 2:mst_mclk_c; 3:mst_mclk_d; 4:mst_mclk_e; 5:mst_mclk_f;



### 10.11.12 TOHDMITX Registers

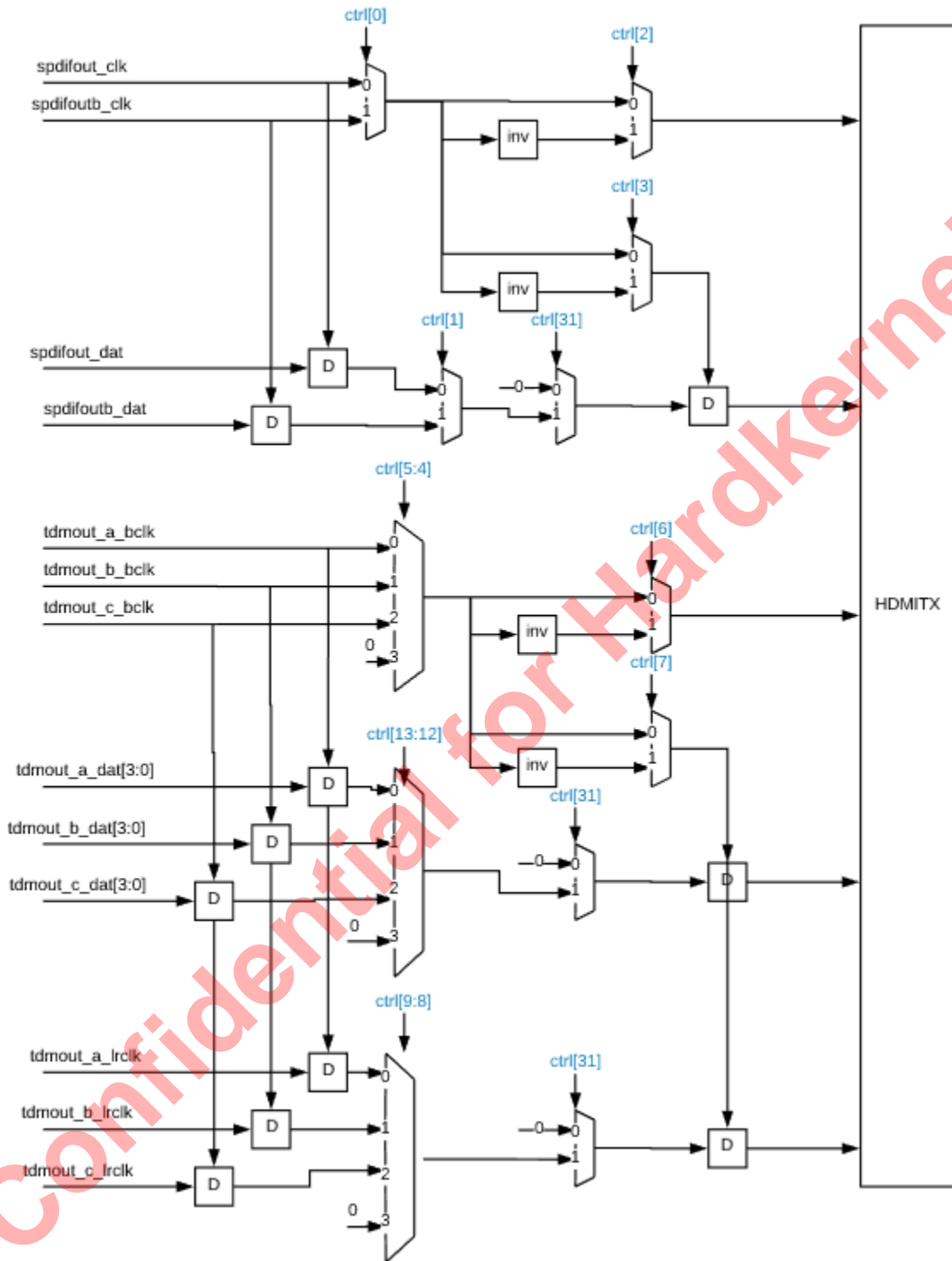

Table 10-172 EE\_AUDIO\_TOHDMITX\_CTRL0 0x1d1

Bits	R/W	Default	Description
31	R/W	0x0000-0000	reg_toacodec_en, 0: disable; 1: enable;
13:12	R/W		dat_sel:

Bits	R/W	Default	Description
			0: tdmout_a_dat; 1: tdmout_b_dat; 2: tdmout_c_dat;
10	R/W		Lrclk_inv;
9:8	R/W		lrclk_sel: 0: tdmout_a_lrclk; 1: tdmout_b_lrclk; 2: tdmout_c_lrclk;
7	R/W		Bclk_cap_inv: The dat_o and lrclk_o will captured for timing balance after select; If this bit set to 1, will use invert bclk to capture;
6	R/W		Bclk_o_inv: if set 1, the final bclk connect to acodec will invert;
5:4	R/W		Bclk_sel: 0: tdmout_a_bclk; 1: tdmout_b_bclk; 2: tdmout_c_bclk;
3	R/W		Spdif_clk_cap_inv: The spdif_dat will captured for timing balance after select; If this bit set to 1, will use invert spdif_clk to capture;
2	R/W		Spdif_clk_o_inv: if set 1, the final bclk connect to hdmix will invert;
1	R/W		Spdif_sel: 0:spdif_out; 1:spdif_out_b;
0	R/W		Spdif_clk_sel: 0:spdif_clk; 1:spdif_clk_b;

### 10.11.13 TOVAD Registers

Table 10-173 EE\_AUDIO\_TOVAD\_CTRL0 0x1d2

Bits	R/W	Default	Description
31	R/W	0x0000-0000	reg_tovad_en, 0: disable; 1: enable;
30	R/W		reg_tovad_v_sel, 0: level; 1:pulse;
14:12	R/W		Data_sel: 0: tadmin_a; 1: tadmin_b; 2: tadmin_c; 3: spdifin; 4: pdmin; 5: loopback_b; 6: tadmin_lb; 7: loopback_a;

### 10.11.14 PDM Registers

Base Address: 0xFF661000

Each register final address = module base address+ address \* 4

**Table 10-174 PDM\_CTRL 0x00**

Bits	R/W	Default	Description
31	R/W	0x0000-0000	PDM enable
30	R/W		invert the PDM_DCLK
29	R/W		output mode: 1: 24bits. 0: 32 bits
28	R/W		bypass mode. 1: bypass all filter. directly output the PDM input to DDR. 0: normal mode.
27:20	R/W		pdm_mute_mask[7:0]; [7] mute pdm ch7; ... [0] mute pdm ch0;
19	R/W		train_en; 1: check value of capture data;
18	R/W		train_clr; 1: clear training status;
17	R/W		chnum_en. 1: start send ch_cnt out.
16	R/W		PDM Asynchronous FIFO soft reset. write 1 to soft reset AFIFO
15:8	R/W		PDM channel reset. 0: to reset each PDM channel. 1: normal mode
7:0	R/W		PDM channel enable. each bit for one channel

**Table 10-175 PDM\_HCIC\_CTRL1 0x01**

Bits	R/W	Default	Description
31	R/W	0x0000-0000	hcic filter enable. 1 use sinc filter. 0 bypass input to output
29:24	R/W		hcic final gain shift parameter
23:16	R/W		hcic final gain multiplier
8:4	R/W		hcic down sample rate
3:0	R/W		hcic stage number. must be between 3 to 9

PDM\_HCIC\_CTRL2 0x02

**Table 10-176 PDM\_F1\_CTRL 0x03**

Bits	R/W	Default	Description
31	R/W	0x0000-0000	filter 1 enable
16:15	R/W		f1 round mode. 2'b00 : sign bit at bit 49. 28bits output [49:22] round at bit 21. 32bits output [49:18]. 24bits output [49:26] 2'b01 : sign bit at bit 50. 28bits output [50:23] round at bit 22. 32bits output [49:18]. 24bits output [49:26] 2'b10 : sign bit at bit 51. 28bits output [51:24] round at bit 23 32bits output [49:18]. 24bits output [49:26].

Bits	R/W	Default	Description
15:12	R/W		filter 1 down sample rate
8:0	R/W		filter 1 stage number

Table 10-177 PDM\_F2\_CTRL 0x04

Bits	R/W	Default	Description
31	R/W	0x0000-0000	filter 2 enable
16:15	R/W		F2 round mode. 2'b00 : round at bit 21. 2'b01 : round at bit 22. 2'b10 : round at bit 23
15:12	R/W		filter 2 down sample rate
8:0	R/W		filter 2 stage number

Table 10-178 PDM\_F3\_CTRL 0x05

Bits	R/W	Default	Description
31	R/W	0x0000-0000	filter 3 enable
16:15	R/W		F3 round mode. 2'b00 : round at bit 21. 2'b01 : round at bit 22. 2'b10 : round at bit 23
15:12	R/W		filter 3 down sample rate
8:0	R/W		filter 3 stage number

Table 10-179 PDM\_HPF\_CTRL 0x06

Bits	R/W	Default	Description
31	R/W	0x0000-0000	High pass filter enable
20:16	R/W		high pass filter shift steps. 6~19 steps
15:0	R/W		high pass filter output factor

Table 10-180 PDM\_CHAN\_CTRL 0x07

Bits	R/W	Default	Description
31:24	R/W	0x0000-0000	Chan3 data sample pointer vs edge of the PDM_DCLK
23:16	R/W		Chan2 data sample pointer vs edge of the PDM_DCLK
15:8	R/W		Chan1 data sample pointer vs edge of the PDM_DCLK
7:0	R/W		Chan0 data sample pointer vs edge of the PDM_DCLK

**Table 10-181 PDM\_CHAN\_CTRL1 0x08**

Bits	R/W	Default	Description
31:24	R/W	0x0000-0000	Chan7 data sample pointer vs edge of the PDM_DCLK
23:16	R/W		Chan6 data sample pointer vs edge of the PDM_DCLK
15:8	R/W		Chan5 data sample pointer vs edge of the PDM_DCLK
7:0	R/W		Chan4 data sample pointer vs edge of the PDM_DCLK

**Table 10-182 PDM\_COEFF\_ADDR 0x09**

Bits	R/W	Default	Description
8:0	R/W	0x0000-0000	address of the write/read of coeff data

**Table 10-183 PDM\_COEFF\_DATA 0x0A**

Bits	R/W	Default	Description
31:0	R/W	0x0000-0000	write/read data to coeff memory

**Table 10-184 PDM\_CLKG\_CTRL 0x0B**

Bits	R/W	Default	Description
6	R/W	0x0000-0000	filt_ctrl module auto clock gating control
5	R/W		sinc fifo module auto clock gating control
4	R/W		filter module auto clock gating control
3	R/W		apb module auto clock gating control
2	R/W		coeff memory module auto clock gating control
1	R/W		each channel module auto clock gating control
0	R/W		cts_pdm_clk auto clock gating control

**Table 10-185 PDM\_STS 0x0C**

Bits	R/W	Default	Description
11:4	R		train result of 8 ch; 1: diff; 0: same;
1	R/W	0x0000-0000	HPF filter output overflow. means the PCLK is too slow
0	R/W		HCIC filter output overflow. means the CTS_PDM_CLK is too slow. can't finished the filter function.

**Table 10-186 PDM\_MUTE\_VALUE 0x0D**

Bits	R/W	Default	Description
31:0	R/W	0x0000-0000	mute value if mute_mask = 1;

**Table 10-187 PDM\_MASK\_NUM 0x0E**

Bits	R/W	Default	Description
15:0	R/W	0x0000-0000	When PDM power on, there are some invalid data because filter initialize. So set this register can mask these invalid data. If PDM out frequency is 48K, set MASK_NUM = 49 will mask 50/48k = 1.04ms.

### 10.11.15 LOCKER Registers

Base Address: 0xFF661400

Each register final address = module base address+ address \* 4

**Table 10-188 AUD\_LOCK\_EN 0X00**

Bit(s)	R/W	Default	Description
31:1			reserved
0	R/W	0x0	Audio_lock_en: 0 = disable; 1 = enable.

**Table 10-189 AUD\_LOCK\_SW\_RESET 0X01**

Bit(s)	R/W	Default	Description
31:1			reserved
0	R/W	0x0	Audio_lock_soft_reset: 1=generate soft reset pulse

**Table 10-190 AUD\_LOCK\_SW\_LATCH 0X02**

Bit(s)	R/W	Default	Description
31:4			reserved
3	R/W	0x0	omclk2ref software latch: 1= generate the latch pulse
2	R/W	0x0	Ref2omclk software latch: 1= generate the latch pulse
1	R/W	0x0	Ref2imclk software latch: 1= generate the latch pulse
0	R/W	0x0	Imclk2ref software latch: 1= generate the latch pulse

**Table 10-191 AUD\_LOCK\_HW\_LATCH 0X03**

Bit(s)	R/W	Default	Description
31:4			reserved
3	R/W	0x0	omclk2ref hardware latch enable: 1= enable 0= disable
2	R/W	0x0	Ref2omclk hardware latch enable: 1= enable 0= disable

Bit(s)	R/W	Default	Description
1	R/W	0x0	Ref2imclk hardware latch enable: 1= enable 0= disable
0	R/W	0x0	Imclk2ref hardware latch enable: 1= enable 0= disable

Table 10-192 AUD\_LOCK\_REFCLK\_SRC 0X04

Bit(s)	R/W	Default	Description
31:2			reserved
1:0	R/W	0x0	Ref clk source sel: 0= pclk; 1=oscinclk; 2,3,reserved

Table 10-193 AUD\_LOCK\_REFCLK\_LAT\_INT 0X05

Bit(s)	R/W	Default	Description
31:0			U32 number of reference clock cycles to latch the imclk and omclk

Table 10-194 AUD\_LOCK\_IMCLK\_LAT\_INT 0X06

Bit(s)	R/W	Default	Description
31:0			U32 number of imclk clock cycles to latch the reference clock

Table 10-195 AUD\_LOCK\_OMCLK\_LAT\_INT 0X07

Bit(s)	R/W	Default	Description
31:0			U32 number of omclk clock cycles to latch the reference clock

Table 10-196 AUD\_LOCK\_REFCLK\_DS\_INT 0X08

Bit(s)	R/W	Default	Description
31:10			reserved
9:0	R/W	0x0	U10 downsample step of reference clock for the counter48ds to be measured, module = x+1

Table 10-197 AUD\_LOCK\_IMCLK\_DS\_INT 0X09

Bit(s)	R/W	Default	Description
31:10			reserved
9:0	R/W	0x0	U10 downsample step of imclk for the counter48ds to be measured, module = x+1

Table 10-198 AUD\_LOCK\_OMCLK\_DS\_INT 0X0a

Bit(s)	R/W	Default	Description
31:10			reserved
9:0	R/W	0x0	U10 downsample step of omclk for the counter48ds to be measured, module = x+1

**Table 10-199 AUD\_LOCK\_INT\_CLR 0X0b**

Bit(s)	R/W	Default	Description
31:2			reserved
1	R/W	0x0	It is used to generate pulse to clear the interrupt status
0	R/W	0x0	It is used to generate pulse to clear the interrupt

**Table 10-200 AUD\_LOCK\_GCLK\_CTRL 0X0c**

Bit(s)	R/W	Default	Description
31:4			reserved
3:2	R/W	0x0	It is used to gate the module clock
1	R/W	0x0	It is used to gate the register clock
0			reserved

**Table 10-201 AUD\_LOCK\_INT\_CTRL 0X0d**

Bit(s)	R/W	Default	Description
31:4			reserved
3	R/W	0x0	It is used to mask interrupt for omclk_state
2	R/W	0x0	It is used to mask interrupt for imclk_state
1	R/W	0x0	It is used to mask interrupt for refclk_state1
0	R/W	0x0	It is used to mask interrupt for refclk_state0

**Table 10-202 RO\_REF2IMCLK\_CNT\_L 0X10**

Bit(s)	R/W	Default	Description
31:0	R	0x0	U48 latched imclk counter48ds of each reg_refclk_latch_interval; Will start from 0 reaching 2^48

**Table 10-203 RO\_REF2IMCLK\_CNT\_H 0X11**

Bit(s)	R/W	Default	Description
31:16			reserved
15:0	R	0x0	U48 latched imclk counter48ds of each reg_refclk_latch_interval; Will start from 0 reaching 2^48

**Table 10-204 RO\_REF2OMCLK\_CNT\_L 0X12**

Bit(s)	R/W	Default	Description
31:0	R	0x0	U48 latched omclk counter48ds of each reg_refclk_latch_interval; Will start from 0 reaching 2^48



Table 10-205 RO\_REF2OMCLK\_CNT\_H 0X13

Bit(s)	R/W	Default	Description
31:16			reserved
15:0	R	0x0	U48 latched omclk counter48ds of each reg_refclk_latch_interval; Will start from 0 reaching 2^48

Table 10-206 RO\_IMCLK2REF\_CNT\_L 0X14

Bit(s)	R/W	Default	Description
31:0	R	0x0	U48 latched reference clock counter48ds of each reg_imclk_latch_interval; Will start from 0 reaching 2^48

Table 10-207 RO\_IMCLK2REF\_CNT\_H 0X15

Bit(s)	R/W	Default	Description
31:16			reserved
15:0	R	0x0	U48 latched reference clock counter48ds of each reg_imclk_latch_interval; Will start from 0 reaching 2^48

Table 10-208 RO\_OMCLK2REF\_CNT\_L 0X16

Bit(s)	R/W	Default	Description
31:0	R	0x0	U48 latched reference clock counter48ds of each reg_omclk_latch_interval; Will start from 0 reaching 2^48

Table 10-209 RO\_OMCLK2REF\_CNT\_H 0X17

Bit(s)	R/W	Default	Description
31:16			reserved
15:0	R	0x0	U48 latched reference clock counter48ds of each reg_omclk_latch_interval; Will start from 0 reaching 2^48

Table 10-210 RO\_REFCLK\_PKG\_CNT 0X18

Bit(s)	R/W	Default	Description
31:16	R	0x0	U16,number of reference clk latch interval period conter for imclk latch
15:0	R	0x0	U16,number of reference clk latch interval period conter for imclk latch

Table 10-211 RO\_IMCLK\_PKG\_CNT 0X19

Bit(s)	R/W	Default	Description
31:16			reserved
15:0	R	0x0	U16,number of imclk latch interval period counter

Table 10-212 RO\_OMCLK\_PKG\_CNT 0X1a

Bit(s)	R/W	Default	Description
31:16			reserved
15:0	R	0x0	U16,number of omclk latch interval period counter

Table 10-213 RO\_AUD\_LOCK\_INT\_STATUS 0X1b

Bit(s)	R/W	Default	Description
31:4			reserved
3	R	0x0	It is used to report interrupt status for omclk_state
2	R	0x0	It is used to report interrupt status for imclk_state
1	R	0x0	It is used to report interrupt status for refclk_state1
0	R	0x0	It is used to report interrupt status for refclk_state0

### 10.11.16 VAD Registers

Base Address: 0xFF661800

Each register final address = module base address+ address \* 4

Table 10-214 EE\_VAD\_TOP\_CTRL0 0x0

Bits	R/W	Default	Description
31	R/W	0	vad_en
30	R/W	0	dec_fir_en
29	R/W	0	pre_emp_en
28	R/W	0	pre_ram_en
27	R/W	0	frame_his_en
26	R/W	0	frame_his_save_en
23	R/W	0	ceps_ceps_en
22	R/W	0	ceps_spec_en
21	R/W	0	post_dec_en
20	R/W	0	two_channel_en
10	R/W	0	soft_rst
9	R/W	0	dec_fir_soft_rst
8	R/W	0	pre_emp_soft_rst
7	R/W	0	proc_soft_rst
6	R/W	0	frame_his_soft_rst
5	R/W	0	frame_his_save_soft_rst

Bits	R/W	Default	Description
4	R/W	0	ceps_win_soft_rst
3	R/W	0	ceps_fft_soft_rst
2	R/W	0	ceps_ceps_soft_rst
1	R/W	0	ceps_spec_soft_rst
0	R/W	0	post_dec_soft_rst

Table 10-215 EE\_VAD\_TOP\_CTRL1 0x1

Bits	R/W	Default	Description
31:30	R/W	0	vad_clk_gate
29:28	R/W	0	prepare_clk_gate
27:26	R/W	0	proc_clk_gate
25:24	R/W	0	frame_his_clk_gate
23:22	R/W	0	ceps_ceps_clk_gate
21:20	R/W	0	ceps_spec_clk_gate
19:18	R/W	0	ch_sel1_clk_gate
17:16	R/W	0	ch_sel0_clk_gate
7	R/W	0	vad_sw_reset
6	R/W	0	prepare_sw_reset
5	R/W	0	proc_sw_reset
4	R/W	0	frame_his_sw_reset
3	R/W	0	ceps_win_sw_reset
2	R/W	0	ceps_ceps_sw_reset
1	R/W	0	ceps_spec_sw_reset
0	R/W	0	post_dec_sw_reset

Table 10-216 EE\_VAD\_TOP\_CTRL2 0x2

Bits	R/W	Default	Description
25:24	R/W	0	ch1_shift :0:0, 1:1, 2:2, 3:3
9:8	R/W	0	ch0_shift:0:0, 1:1, 2:2, 3:3

Table 10-217 VAD\_FIR\_CTRL 0x3

Bits	R/W	Default	Description
29:24	R/W	0	dec_filter_order
15:8	R/W	0	dec_filter_depthm1 ;>= filter pipe+ order
3:0	R/W	0	dec_rate;decimation_rate-1(0~11)

**Table 10-218 VAD\_FIR\_EMP 0x4**

Bits	R/W	Default	Description
9:0	R/W	0	pre_emp_coef :float unsigned

**Table 10-219 VAD\_FIR\_COEF 0 0x5**

Bits	R/W	Default	Description
31:16	R/W	0	dec_coef_0 : 8.1.1.7
15:0	R/W	0	dec_coef_1 : 8.1.1.7

**Table 10-220 VAD\_FIR\_COEF 1 0x6**

Bits	R/W	Default	Description
31:16	R/W	0	dec_coef_2 : 8.1.1.7
15:0	R/W	0	dec_coef_3 : 8.1.1.7

**Table 10-221 VAD\_FIR\_COEF 2 0x7**

Bits	R/W	Default	Description
31:16	R/W	0	dec_coef_4 : 8.1.1.7
15:0	R/W	0	dec_coef_5 : 8.1.1.7

**Table 10-222 VAD\_FIR\_COEF 3 0x8**

Bits	R/W	Default	Description
31:16	R/W	0	dec_coef_6 : 8.1.1.7
15:0	R/W	0	dec_coef_7 : 8.1.1.7

**Table 10-223 VAD\_FIR\_COEF 4 0x9**

Bits	R/W	Default	Description
31:16	R/W	0	dec_coef_8 : 8.1.1.7
15:0	R/W	0	dec_coef_9 : 8.1.1.7

**Table 10-224 VAD\_FIR\_COEF 5 0xa**

Bits	R/W	Default	Description
31:16	R/W	0	dec_coef_10 : 8.1.1.7
15:0	R/W	0	dec_coef_11 : 8.1.1.7

**Table 10-225 VAD\_FIR\_COEF 6 0xb**

Bits	R/W	Default	Description
31:16	R/W	0	dec_coef_12 : 8.1.1.7
15:0	R/W	0	dec_coef_13 : 8.1.1.7

**Table 10-226 VAD\_FIR\_COEF 7 0xc**

Bits	R/W	Default	Description
31:16	R/W	0	dec_coef_14 : 8.1.1.7
15:0	R/W	0	dec_coef_15 : 8.1.1.7

**Table 10-227 VAD\_FIR\_COEF 8 0xd**

Bits	R/W	Default	Description
31:16	R/W	0	dec_coef_16 : 8.1.1.7
15:0	R/W	0	dec_coef_17 : 8.1.1.7

**Table 10-228 VAD\_FIR\_COEF 9 0xe**

Bits	R/W	Default	Description
31:16	R/W	0	dec_coef_18 : 8.1.1.7
15:0	R/W	0	dec_coef_19 : 8.1.1.7

**Table 10-229 VAD\_FIR\_COEF 10 0xf**

Bits	R/W	Default	Description
31:16	R/W	0	dec_coef_20 : 8.1.1.7
15:0	R/W	0	dec_coef_21 : 8.1.1.7

**Table 10-230 VAD\_FIR\_COEF 11 0x10**

Bits	R/W	Default	Description
31:16	R/W	0	dec_coef_22 : 8.1.1.7
15:0	R/W	0	dec_coef_23 : 8.1.1.7

**Table 10-231 VAD\_FIR\_COEF 12 0x11**

Bits	R/W	Default	Description
31:16	R/W	0	dec_coef_24 : 8.1.1.7

**Table 10-232 VAD\_FRAME\_CTRL0 0x12**

Bits	R/W	Default	Description
31:30	R/W	0	frame_len 0: 64, 1: 128, 2: 256
26:24	R/W	0	pow_diff_dist:0:4, 1:8, 3:16, 5:24
17:16	R/W	0	pow_old_avglen:0:4, 1:8,3:16

**Table 10-233 VAD\_FRAME\_CTRL1 0x13**

Bits	R/W	Default	Description
10:0	R/W	0	pow_rampup_thr: 8.8.0.5

**Table 10-234 VAD\_FRAME\_CTRL2 0x14**

Bits	R/W	Default	Description
31:16	R/W	0	pow_cur_thr : 10.0.0.52
15:0	R/W	0	pow_cur_thr_high: 10.0.0.52

**Table 10-235 VAD\_CEP\_CTRL0 0x15**

Bits	R/W	Default	Description
29:28	R/W	0	ceps_decision_sel: 0 :   , 1: &&, 2:naxm 3:maxmin
25:24	R/W	0	decision_sel_each:0 :   , 1: &&, 2:spectral_entropy 3:ceps
20:16	R/W	0	login_min: $2^{(-\log n_{\min})}$ ,5.5.0, [0~20]
10:0	R/W	0	ceps_log_blk: 11.6.1

**Table 10-236 VAD\_CEP\_CTRL1 0x16**

Bits	R/W	Default	Description
8:0	R/W	0	ceps_weight_step : 9,-3,0

**Table 10-237 VAD\_CEP\_CTRL2 0x17**

Bits	R/W	Default	Description
31:16	R/W	0	ceps_max_thr :16.9.1
15:0	R/W	0	ceps_maxmin_thr :16.9.1

**Table 10-238 VAD\_CEP\_CTRL3 0x18**

Bits	R/W	Default	Description
31:24	R/W	0	ceps_det_start: [0~128]
23:16	R/W	0	ceps_det_end: [0~128], end>start

Bits	R/W	Default	Description
14:8	R/W	0	ceps_freq_blk_low: 0: no blk, 1:blk[0], 2 blank [255 0 1]...
6:0	R/W	0	ceps_freq_blk_high: 0:no blk, 1:blk[128],2 blk[127:129]...

Table 10-239 VAD\_CEP\_CTRL4 0x19

Bits	R/W	Default	Description
30:24	R/W	0	spectral_entropy_start: [0~127]
22:16	R/W	0	spectral_entropy_end: [0~127]

Table 10-240 VAD\_CEP\_CTRL5 0x1a

Bits	R/W	Default	Description
27:16	R/W	0	spectral_entropy_thr_max: 12.7.1
11:0	R/W	0	spectral_entropy_thr_min: 12.7.1

Table 10-241 VAD\_DEC\_CTRL 0x1b

Bits	R/W	Default	Description
29:28	R/W	0	decision_sel_combine: 0 is &, 1 is  , 2 is +
20:16	R/W	0	vadflag_confirm_m: <32
5:0	R/W	0	vadflag_confirm_n

Table 10-242 VAD\_TOP\_STS0 0x1c

Bits	R/W	Default	Description
4	R	0	Afifo_err
3:0	R	0	lafifo_cnt

Table 10-243 VAD\_TOP\_STS1 0x1d

Bits	R/W	Default	Description
20	R	0	Pre_overflow
19	R	0	Pre_fst
18	R	0	Pre_val
17:0	R	0	Pre_dat

**Table 10-244 VAD\_TOP\_STS2 0x1e**

Bits	R/W	Default	Description
18	R	0	Ceps_val
17:0	R	0	Ceps_dat

**Table 10-245 VAD\_FIR\_STS0 0x1f**

Bits	R/W	Default	Description
31:0	R	0	reserved

**Table 10-246 VAD\_FIR\_STS1 0x20**

Bits	R/W	Default	Description
31:-	R	0	reserved

**Table 10-247 VAD\_POW\_STS0 0x21**

Bits	R/W	Default	Description
31:16	R	0	reserved
15:0	R	0	Pow_o

**Table 10-248 VAD\_POW\_STS1 0x22**

Bits	R/W	Default	Description
31:0	R	0	reserved

**Table 10-249 VAD\_POW\_STS2 0x23**

Bits	R/W	Default	Description
31:0	R	0	reserved

**Table 10-250 VAD\_FFT\_STS0 0x24**

Bits	R/W	Default	Description
31	R	0	Ceps_done_latch
30	R	0	Spec_entropy_done
29	R	0	Cepstrum_done

**Table 10-251 VAD\_FFT\_STS1 0x25**

Bits	R/W	Default	Description
11:0	R	0	Se_o



**Table 10-252 VAD\_SPE\_STS0 0x26**

Bits	R/W	Default	Description
31:16	R	0	Cepsw_o_h
15:0	R	0	Cepsw_o_l

**Table 10-253 VAD\_SPE\_STS1 0x27**

Bits	R/W	Default	Description
31:16	R	0	Cur_pow

**Table 10-254 VAD\_SPE\_STS2 0x28**

Bits	R/W	Default	Description
31:0	R	0	Calc_q_pre

**Table 10-255 VAD\_SPE\_STS3 0x29**

Bits	R/W	Default	Description
31:0	R	0	Reserved

**Table 10-256 VAD\_DEC\_STS0 0x2a**

Bits	R/W	Default	Description
31:0	R	0	Reserved

**Table 10-257 VAD\_DEC\_STS1 0x2b**

Bits	R/W	Default	Description
31:0	R	0	Reserved

**Table 10-258 VAD\_LUT\_CTRL 0x2c**

Bits	R/W	Default	Description
31	R/W	0	win_lut_w
30	R/W	0	win_lut_r
6:0	R/W	0	win_lut_addr

**Table 10-259 VAD\_LUT\_WR 0x2d**

Bits	R/W	Default	Description
31:0	R/W	0	Win_lut_wr:12.0.0.7

**Table 10-260 VAD\_LUT\_RD 0x2e**

Bits	R/W	Default	Description
31:0	R	0	Win_lut_rd:12.0.0.7

**Table 10-261 VAD\_IN\_SEL0 0x2f**

Bits	R/W	Default	Description
31:0	R/W	0	ch0_sel: reg_vad.gen_vadin_coeff, bit[n] for ch_n enable

**Table 10-262 VAD\_IN\_SEL1 0x30**

Bits	R/W	Default	Description
31:0	R/W	0	Ch1_sel: reg_vad.gen_vadin_coeff, bit[n] for ch_n enable

**Table 10-263 VAD\_TO\_DDR 0x31**

Bits	R/W	Default	Description
31	R/W	0	vad_to_ddr_en
30	R/W	0	vad_to_ddr_rst
29	R/W	0	vad_to_ddr_eo
27:16	R/W	0	vad_to_ddr_cur_cnt
11:0	R/W	0	vad_to_ddr_max_cnt

### 10.11.17 EQDRC Registers

EQDRC Registers Base Address: 0xFF662000

Each register final address = module base address+ address \* 4

**Table 10-264 EE\_AED\_COEF\_RAM\_CNTL 0x0**

Bits	R/W	Default	Description
31-10	R/W	0x0	reserved;
9-2	R/W	0x0	addr: read or write the addr of coef ram
1	R/W	0x0	rd/wr: 0 read from coef ram; 1 write to coef ram
0	R/W	0x0	valid: 0 the command had been finish; 1 the command wait to be done

**Table 10-265 EE\_AED\_COEF\_RAM\_DATA 0x1**

Bits	R/W	Default	Description
31-26	R/W	0x0	reserved;
25-0	R/W	0x0	data: read from coef ram or write to coef ram

**Table 10-266 EE\_AED\_EQ\_EN 0x2**

Bits	R/W	Default	Description
31-2	R/W	0x0	reserved;
1	R/W	0x0	eq2_en: It is used to enable EQ for ch3 and ch4. 1= enable, 0 = bypass.
0	R/W	0x0	eq1_en: It is used to enable EQ for ch1 and ch2. 1= enable, 0 = bypass.

**Table 10-267 EE\_AED\_TAP\_CNTL 0x3**

Bits	R/W	Default	Description
31-26	R/W	0x0	reserved;
9-5	R/W	0xa	eq2_tap: It is used to set the tap for EQ2.
4-0	R/W	0xa	eq1_tap: It is used to set the tap for EQ1.

**Table 10-268 EE\_AED\_EQ\_VOLUME 0x4**

Bits	R/W	Default	Description
31-30	R/W	0x0	volume_step: It is used to set volume adjust step.
29-26	R/W	0x0	reserved;
25-16	R/W	0x0	volume_master: It is used to set master volume.
15-8	R/W	0x0	volume_ch2: It is used to set channel2 volume.
7-0	R/W	0x0	volume_ch1: It is used to set channel1 volume.

**Table 10-269 EE\_AED\_EQ\_VOLUME\_SLEW\_CNT 0x5**

Bits	R/W	Default	Description
31-12	R/W	0x0	reserved;
11-0	R/W	0x0	volume_slew_cnt: It is used to control volume change and mute ramp rate.

**Table 10-270 EE\_AED\_MUTE 0x6**

Bits	R/W	Default	Description
31	R/W	0x0	mute_master: It is used to mute all.
30-2	R/W	0x0	reserved;
1	R/W	0x0	mute_ch2: It is used to mute channel1.
0	R/W	0x0	mute_ch1: It is used to mute channel1.

**Table 10-271 EE\_AED\_DRC\_CNTL 0x7**

Bits	R/W	Default	Description
31-6	R/W	0x0	reserved;
5-3	R/W	0x0	drc_tap: It is used to set the power tap for DRC.

Bits	R/W	Default	Description
2	R/W	0x0	drc_pow_sel: It is used to select the input of gain alpha filter. 0 = dB domain, 1 = decimal domain
1	R/W	0x0	drc_rms_mode: It is used to select the mode of pow calculation. 0 = RMS, 1= peaking
0	R/W	0x0	drc_en: It is used to enable the post DRC. 1= enable, 0 = bypass.

Table 10-272 EE\_AED\_DRC\_RMS\_COEF0 0x8

Bits	R/W	Default	Description
31-26	R/W	0x0	reserved;
25-0	R/W	0x0	It is used to set the coefficient for power calculation filter.

Table 10-273 EE\_AED\_DRC\_RMS\_COEF1 0x9

Bits	R/W	Default	Description
31-26	R/W	0x0	reserved;
25-0	R/W	0x0	It is used to set the coefficient for power calculation filter.

Table 10-274 EE\_AED\_DRC\_THD0 0x0a

Bits	R/W	Default	Description
31-0	R/W	0x0	It is used to set the power threshold0 for DRC.

Table 10-275 EE\_AED\_DRC\_THD1 0x0b

Bits	R/W	Default	Description
31-0	R/W	0x0	It is used to set the power threshold1 for DRC.

Table 10-276 EE\_AED\_DRC\_THD2 0x0c

Bits	R/W	Default	Description
31-0	R/W	0x0	It is used to set the power threshold2 for DRC.

Table 10-277 EE\_AED\_DRC\_THD3 0x0d

Bits	R/W	Default	Description
31-0	R/W	0x0	It is used to set the power threshold3 for DRC.

Table 10-278 EE\_AED\_DRC\_THD4 0x0e

Bits	R/W	Default	Description
31-0	R/W	0x0	It is used to set the power threshold4 for DRC.

**Table 10-279 EE\_AED\_DRC\_K0 0x0f**

Bits	R/W	Default	Description
31-26	R/W	0x0	reserved;
25-0	R/W	0x0	It is used to set the k-slope of gain for tap 0.

**Table 10-280 EE\_AED\_DRC\_K1 0x10**

Bits	R/W	Default	Description
31-26	R/W	0x0	reserved;
25-0	R/W	0x0	It is used to set the k-slope of gain for tap 1.

**Table 10-281 EE\_AED\_DRC\_K2 0x11**

Bits	R/W	Default	Description
31-26	R/W	0x0	reserved;
25-0	R/W	0x0	It is used to set the k-slope of gain for tap 2.

**Table 10-282 EE\_AED\_DRC\_K3 0x12**

Bits	R/W	Default	Description
31-26	R/W	0x0	reserved;
25-0	R/W	0x0	It is used to set the k-slope of gain for tap 3.

**Table 10-283 EE\_AED\_DRC\_K4 0x13**

Bits	R/W	Default	Description
31-26	R/W	0x0	reserved;
25-0	R/W	0x0	It is used to set the k-slope of gain for tap 4.

**Table 10-284 EE\_AED\_DRC\_K5 0x14**

Bits	R/W	Default	Description
31-26	R/W	0x0	reserved;
25-0	R/W	0x0	It is used to set the k-slope of gain for tap 5.

**Table 10-285 EE\_AED\_DRC\_THD\_OUT0 0x15**

Bits	R/W	Default	Description
31-0	R/W	0x0	It is used to set the power threshold_out0 for DRC.

**Table 10-286 EE\_AED\_DRC\_THD\_OUT1 0x16**

Bits	R/W	Default	Description
31-0	R/W	0x0	It is used to set the power threshold_out1 for DRC.

**Table 10-287 EE\_AED\_DRC\_THD\_OUT2 0x17**

Bits	R/W	Default	Description
31-0	R/W	0x0	It is used to set the power threshold_out2 for DRC.

**Table 10-288 EE\_AED\_DRC\_THD\_OUT3 0x18**

Bits	R/W	Default	Description
31-0	R/W	0x0	It is used to set the power threshold_out3 for DRC.

**Table 10-289 EE\_AED\_DRC\_OFFSET 0x19**

Bits	R/W	Default	Description
31-0	R/W	0x0	It is used to set the power offset of DRC.

**Table 10-290 EE\_AED\_DRC\_RELEASE\_COEF00 0x1a**

Bits	R/W	Default	Description
31-26	R/W	0x0	reserved;
25-0	R/W	0x0	It is used to set the coefficient for gain release filter.

**Table 10-291 EE\_AED\_DRC\_RELEASE\_COEF01 0x1b**

Bits	R/W	Default	Description
31-26	R/W	0x0	reserved;
25-0	R/W	0x0	It is used to set the coefficient for gain release filter.

**Table 10-292 EE\_AED\_DRC\_RELEASE\_COEF10 0x1c**

Bits	R/W	Default	Description
31-26	R/W	0x0	reserved;
25-0	R/W	0x0	It is used to set the coefficient for gain release filter.

**Table 10-293 EE\_AED\_DRC\_RELEASE\_COEF11 0x1d**

Bits	R/W	Default	Description
31-26	R/W	0x0	reserved;
25-0	R/W	0x0	It is used to set the coefficient for gain release filter.

**Table 10-294 EE\_AED\_DRC\_RELEASE\_COEF20 0x1e**

Bits	R/W	Default	Description
31-26	R/W	0x0	reserved;
25-0	R/W	0x0	It is used to set the coefficient for gain release filter.

**Table 10-295 EE\_AED\_DRC\_RELEASE\_COEF21 0x1f**

Bits	R/W	Default	Description
31-26	R/W	0x0	reserved;
25-0	R/W	0x0	It is used to set the coefficient for gain release filter.

**Table 10-296 EE\_AED\_DRC\_RELEASE\_COEF30 0x20**

Bits	R/W	Default	Description
31-26	R/W	0x0	reserved;
25-0	R/W	0x0	It is used to set the coefficient for gain release filter.

**Table 10-297 EE\_AED\_DRC\_RELEASE\_COEF31 0x21**

Bits	R/W	Default	Description
31-26	R/W	0x0	reserved;
25-0	R/W	0x0	It is used to set the coefficient for gain release filter.

**Table 10-298 EE\_AED\_DRC\_RELEASE\_COEF40 0x22**

Bits	R/W	Default	Description
31-26	R/W	0x0	reserved;
25-0	R/W	0x0	It is used to set the coefficient for gain release filter.

**Table 10-299 EE\_AED\_DRC\_RELEASE\_COEF41 0x23**

Bits	R/W	Default	Description
31-26	R/W	0x0	reserved;
25-0	R/W	0x0	It is used to set the coefficient for gain release filter.

**Table 10-300 EE\_AED\_DRC\_RELEASE\_COEF50 0x24**

Bits	R/W	Default	Description
31-26	R/W	0x0	reserved;
25-0	R/W	0x0	It is used to set the coefficient for gain release filter.

**Table 10-301 EE\_AED\_DRC\_RELEASE\_COEF51 0x25**

Bits	R/W	Default	Description
31-26	R/W	0x0	reserved;
25-0	R/W	0x0	It is used to set the coefficient for gain release filter.

**Table 10-302 EE\_AED\_DRC\_ATTACK\_COEF00 0x26**

Bits	R/W	Default	Description
31-26	R/W	0x0	reserved;
25-0	R/W	0x0	It is used to set the coefficient for gain attack filter.

**Table 10-303 EE\_AED\_DRC\_ATTACK\_COEF01 0x27**

Bits	R/W	Default	Description
31-26	R/W	0x0	reserved;
25-0	R/W	0x0	It is used to set the coefficient for gain attack filter.

**Table 10-304 EE\_AED\_DRC\_ATTACK\_COEF10 0x28**

Bits	R/W	Default	Description
31-26	R/W	0x0	reserved;
25-0	R/W	0x0	It is used to set the coefficient for gain attack filter.

**Table 10-305 EE\_AED\_DRC\_ATTACK\_COEF11 0x29**

Bits	R/W	Default	Description
31-26	R/W	0x0	reserved;
25-0	R/W	0x0	It is used to set the coefficient for gain attack filter.

**Table 10-306 EE\_AED\_DRC\_ATTACK\_COEF20 0x2a**

Bits	R/W	Default	Description
31-26	R/W	0x0	reserved;
25-0	R/W	0x0	It is used to set the coefficient for gain attack filter.

**Table 10-307 EE\_AED\_DRC\_ATTACK\_COEF21 0x2b**

Bits	R/W	Default	Description
31-26	R/W	0x0	reserved;
25-0	R/W	0x0	It is used to set the coefficient for gain attack filter.



**Table 10-308 EE\_AED\_DRC\_ATTACK\_COEF30 0x2c**

Bits	R/W	Default	Description
31-26	R/W	0x0	reserved;
25-0	R/W	0x0	It is used to set the coefficient for gain attack filter.

**Table 10-309 EE\_AED\_DRC\_ATTACK\_COEF31 0x2d**

Bits	R/W	Default	Description
31-26	R/W	0x0	reserved;
25-0	R/W	0x0	It is used to set the coefficient for gain attack filter.

**Table 10-310 EE\_AED\_DRC\_ATTACK\_COEF40 0x2e**

Bits	R/W	Default	Description
31-26	R/W	0x0	reserved;
25-0	R/W	0x0	It is used to set the coefficient for gain attack filter.

**Table 10-311 EE\_AED\_DRC\_ATTACK\_COEF41 0x2f**

Bits	R/W	Default	Description
31-26	R/W	0x0	reserved;
25-0	R/W	0x0	It is used to set the coefficient for gain attack filter.

**Table 10-312 EE\_AED\_DRC\_ATTACK\_COEF50 0x30**

Bits	R/W	Default	Description
31-26	R/W	0x0	reserved;
25-0	R/W	0x0	It is used to set the coefficient for gain attack filter.

**Table 10-313 EE\_AED\_DRC\_ATTACK\_COEF51 0x31**

Bits	R/W	Default	Description
31-26	R/W	0x0	reserved;
25-0	R/W	0x0	It is used to set the coefficient for gain attack filter.

**Table 10-314 EE\_AED\_DRC\_LOOPBACK\_CNTL 0x32**

Bits	R/W	Default	Description
31-26	R/W	0x0	reserved;
17	R/W	0x0	dis_fifo_rst: 0 if drc_loopback_cnt change, then reset fifo; 1 don't reset
16	R/W	0x0	drc_loopback_bypass: It is used to set bypass look-ahead mode. 1= bypass.

Bits	R/W	Default	Description
15-9	R/W	0x0	reserved;
8-0	R/W	0x0	drc_loopback_cnt: It is used to set the look-ahead count.

Table 10-315 EE\_AED\_MDRC\_CNTL 0x33

Bits	R/W	Default	Description
31-17	R/W	0x0	reserved;
16	R/W	0x0	mdrc_pow_sel: It is used to select the input of gain alpha filter. 0 = dB domain, 1 = decimal domain
15-9	R/W	0x0	reserved;
8	R/W	0x0	mdrc_all_en: It is used to enable the entire multi-band DRC. 1= enable, 0 = bypass.
7-6	R/W	0x0	reserved;
5-3	R/W	0x0	[3] mdrc_rms_mode: It is used to select the band0 mode of pow calculation. 0 = RMS, 1= peaking It is used to select the band1 mode of pow calculation. 0 = RMS, 1= peaking It is used to select the band2 mode of pow calculation. 0 = RMS, 1= peaking
2-0	R/W	0x0	[0] mdrc_en: It is used to enable the band 0 of MDRC. 1= enable, 0 = bypass. It is used to enable the band 1 of MDRC. 1= enable, 0 = bypass. It is used to enable the band 2 of MDRC. 1= enable, 0 = bypass.

Table 10-316 EE\_AED\_MDRC\_RMS\_COEF00 0x34

Bits	R/W	Default	Description
31-26	R/W	0x0	reserved;
25-0	R/W	0x0	It is used to set the coefficient for power calculation filter.

Table 10-317 EE\_AED\_MDRC\_RMS\_COEF01 0x35

Bits	R/W	Default	Description
31-26	R/W	0x0	reserved;
25-0	R/W	0x0	It is used to set the coefficient for power calculation filter.

Table 10-318 EE\_AED\_MDRC\_RELEASE\_COEF00 0x36

Bits	R/W	Default	Description
31-26	R/W	0x0	reserved;
25-0	R/W	0x0	It is used to set the coefficient for gain release filter.

**Table 10-319 EE\_AED\_MDRC\_RELEASE\_COEF01 0x37**

Bits	R/W	Default	Description
31-26	R/W	0x0	reserved;
25-0	R/W	0x0	It is used to set the coefficient for gain release filter.

**Table 10-320 EE\_AED\_MDRC\_ATTACK\_COEF00 0x38**

Bits	R/W	Default	Description
31-26	R/W	0x0	reserved;
25-0	R/W	0x0	It is used to set the coefficient for gain attack filter.

**Table 10-321 EE\_AED\_MDRC\_ATTACK\_COEF01 0x39**

Bits	R/W	Default	Description
31-26	R/W	0x0	reserved;
25-0	R/W	0x0	It is used to set the coefficient for gain attack filter.

**Table 10-322 EE\_AED\_MDRC\_THD0 0x3a**

Bits	R/W	Default	Description
31-0	R/W	0x0	It is used to set the power threshold for DRC.

**Table 10-323 EE\_AED\_MDRC\_K0 0x3b**

Bits	R/W	Default	Description
31-26	R/W	0x0	reserved;
25-0	R/W	0x0	It is used to set the k-slope of gain.

**Table 10-324 EE\_AED\_MDRC\_LOW\_GAIN 0x3c**

Bits	R/W	Default	Description
31-26	R/W	0x0	reserved;
25-0	R/W	0x0	It is used to set the gain for DRC band 0.

**Table 10-325 EE\_AED\_MDRC\_OFFSET0 0x3d**

Bits	R/W	Default	Description
31-0	R/W	0x0	It is used to set the power offset of DRC.

**Table 10-326 EE\_AED\_MDRC\_RMS\_COEF10 0x3e**

Bits	R/W	Default	Description
31-26	R/W	0x0	reserved;
25-0	R/W	0x0	It is used to set the coefficient for power calculation filter.

**Table 10-327 EE\_AED\_MDRC\_RMS\_COEF11 0x3f**

Bits	R/W	Default	Description
31-26	R/W	0x0	reserved;
25-0	R/W	0x0	It is used to set the coefficient for power calculation filter.

**Table 10-328 EE\_AED\_MDRC\_RELEASE\_COEF10 0x40**

Bits	R/W	Default	Description
31-26	R/W	0x0	reserved;
25-0	R/W	0x0	It is used to set the coefficient for gain release filter.

**Table 10-329 EE\_AED\_MDRC\_RELEASE\_COEF11 0x41**

Bits	R/W	Default	Description
31-26	R/W	0x0	reserved;
25-0	R/W	0x0	It is used to set the coefficient for gain release filter.

**Table 10-330 EE\_AED\_MDRC\_ATTACK\_COEF10 0x42**

Bits	R/W	Default	Description
31-26	R/W	0x0	reserved;
25-0	R/W	0x0	It is used to set the coefficient for gain attack filter.

**Table 10-331 EE\_AED\_MDRC\_ATTACK\_COEF11 0x43**

Bits	R/W	Default	Description
31-26	R/W	0x0	reserved;
25-0	R/W	0x0	It is used to set the coefficient for gain attack filter.

**Table 10-332 EE\_AED\_MDRC\_THD1 0x44**

Bits	R/W	Default	Description
31-0	R/W	0x0	It is used to set the power threshold for DRC.

**Table 10-333 EE\_AED\_MDRC\_K1 0x45**

Bits	R/W	Default	Description
31-26	R/W	0x0	reserved;
25-0	R/W	0x0	It is used to set the k-slope of gain.

**Table 10-334 EE\_AED\_MDRC\_OFFSET1 0x46**

Bits	R/W	Default	Description
31-0	R/W	0x0	It is used to set the power offset of DRC.

**Table 10-335 EE\_AED\_MDRC\_MID\_GAIN 0x47**

Bits	R/W	Default	Description
31-26	R/W	0x0	reserved;
25-0	R/W	0x0	It is used to set the gain for DRC band 1.

**Table 10-336 EE\_AED\_MDRC\_RMS\_COEF20 0x48**

Bits	R/W	Default	Description
31-26	R/W	0x0	reserved;
25-0	R/W	0x0	It is used to set the coefficient for power calculation filter.

**Table 10-337 EE\_AED\_MDRC\_RMS\_COEF21 0x49**

Bits	R/W	Default	Description
31-26	R/W	0x0	reserved;
25-0	R/W	0x0	It is used to set the coefficient for power calculation filter.

**Table 10-338 EE\_AED\_MDRC\_RELEASE\_COEF20 0x4a**

Bits	R/W	Default	Description
31-26	R/W	0x0	reserved;
25-0	R/W	0x0	It is used to set the coefficient for gain release filter.

**Table 10-339 EE\_AED\_MDRC\_RELEASE\_COEF21 0x4b**

Bits	R/W	Default	Description
31-26	R/W	0x0	reserved;
25-0	R/W	0x0	It is used to set the coefficient for gain release filter.

**Table 10-340 EE\_AED\_MDRC\_ATTACK\_COEF20 0x4c**

Bits	R/W	Default	Description
31-26	R/W	0x0	reserved;
25-0	R/W	0x0	It is used to set the coefficient for gain attack filter.

**Table 10-341 EE\_AED\_MDRC\_ATTACK\_COEF21 0x4d**

Bits	R/W	Default	Description
31-26	R/W	0x0	reserved;
25-0	R/W	0x0	It is used to set the coefficient for gain attack filter.

**Table 10-342 EE\_AED\_MDRC\_THD2 0x4e**

Bits	R/W	Default	Description
31-0	R/W	0x0	It is used to set the power threshold for DRC.

**Table 10-343 EE\_AED\_MDRC\_K2 0x4f**

Bits	R/W	Default	Description
31-26	R/W	0x0	reserved;
25-0	R/W	0x0	It is used to set the k-slope of gain.

**Table 10-344 EE\_AED\_MDRC\_OFFSET2 0x50**

Bits	R/W	Default	Description
31-0	R/W	0x0	It is used to set the power offset of DRC.

**Table 10-345 EE\_AED\_MDRC\_HIGH\_GAIN 0x51**

Bits	R/W	Default	Description
31-26	R/W	0x0	reserved;
25-0	R/W	0x0	It is used to set the gain for DRC band 1.

**Table 10-346 EE\_AED\_ED\_CNTL 0x52**

Bits	R/W	Default	Description
31-2	R/W	0x0	reserved;
1	R/W	0x0	ed_sign:
0	R/W	0x0	ed_int: soft reset

**Table 10-347 EE\_AED\_DC\_EN 0x53**

Bits	R/W	Default	Description
31-1	R/W	0x0	reserved;
0	R/W	0x0	It is used to enable the noise detection. 1= enable, 0 = bypass.

**Table 10-348 EE\_AED\_ND\_LOW\_THD 0x54**

Bits	R/W	Default	Description
31-24	R/W	0x0	reserved;
23-0	R/W	0x0	It is used to set the low threshold for detection.

**Table 10-349 EE\_AED\_ND\_HIGH\_THD 0x55**

Bits	R/W	Default	Description
31-24	R/W	0x0	reserved;
23-0	R/W	0x0	It is used to set the high threshold for detection. If the signal amplitude is bigger than it, the signal is not noise.

**Table 10-350 EE\_AED\_ND\_CNT\_THD 0x56**

Bits	R/W	Default	Description
31-16	R/W	0x0	reserved;
15-0	R/W	0x0	It is used to set the counter threshold for amplitude detection. If the counter for which the signal is smaller than reg_nd_low_thd continuously is bigger than it, the signal is noise.

**Table 10-351 EE\_AED\_ND\_SUM\_NUM 0x57**

Bits	R/W	Default	Description
31-16	R/W	0x0	reserved;
15-0	R/W	0x0	It is used to set the statistical number for sum of signal amplitude.

**Table 10-352 EE\_AED\_ND\_CZ\_SUM 0x58**

Bits	R/W	Default	Description
31-16	R/W	0x0	reserved;
15-0	R/W	0x0	It is used to set the statistical number for zero-crossing.

**Table 10-353 EE\_AED\_ND\_SUM\_THD0 0x59**

Bits	R/W	Default	Description
31-0	R/W	0x0	It is used to set the low threshold for sum of amplitude.

**Table 10-354 EE\_AED\_ND\_SUM\_THD1 0x5a**

Bits	R/W	Default	Description
31-0	R/W	0x0	It is used to set the high threshold for sum of amplitude.

**Table 10-355 EE\_AED\_ND\_CZ\_THD0 0x5b**

Bits	R/W	Default	Description
31-16	R/W	0x0	reserved;
15-0	R/W	0x0	It is used to set the low threshold for zero-crossing number.

**Table 10-356 EE\_AED\_ND\_CZ\_THD1 0x5c**

Bits	R/W	Default	Description
31-16	R/W	0x0	reserved;
15-0	R/W	0x0	It is used to set the high threshold for zero-crossing number.

**Table 10-357 EE\_AED\_ND\_COND\_CNTL 0x5d**

Bits	R/W	Default	Description
31-6	R/W	0x0	reserved;
5	R/W	0x0	Reg_nd_audio_cond2_en: It is used to enable the audio detection for amplitude.
4	R/W	0x0	Reg_nd_audio_cond1_en: It is used to enable the audio detection for amplitude.
3	R/W	0x0	Reg_nd_audio_cond0_en: It is used to enable the audio detection for amplitude.
2	R/W	0x0	Reg_nd_noise_cond2_en: It is used to enable the noise detection for amplitude.
1	R/W	0x0	Reg_nd_noise_cond1_en: It is used to enable the noise detection for amplitude.
0	R/W	0x0	Reg_nd_noise_cond0_en: It is used to enable the noise detection for amplitude.

**Table 10-358 EE\_AED\_ND\_RELEASE\_COEF0 0x5e**

Bits	R/W	Default	Description
31-26	R/W	0x0	reserved;
25-0	R/W	0x0	It is used to set the coefficients for release filter when gain adjusting.

**Table 10-359 EE\_AED\_ND\_RELEASE\_COEF1 0x5f**

Bits	R/W	Default	Description
31-26	R/W	0x0	reserved;
25-0	R/W	0x0	It is used to set the coefficients for release filter when gain adjusting.



**Table 10-360 EE\_AED\_ND\_ATTACK\_COEF0 0x60**

Bits	R/W	Default	Description
31-26	R/W	0x0	reserved;
25-0	R/W	0x0	It is used to set the coefficients for attack filter when gain adjusting.

**Table 10-361 EE\_AED\_ND\_ATTACK\_COEF1 0x61**

Bits	R/W	Default	Description
31-26	R/W	0x0	reserved;
25-0	R/W	0x0	It is used to set the coefficients for attack filter when gain adjusting.

**Table 10-362 EE\_AED\_ND\_ATTACK\_COEF1 0x61**

Bits	R/W	Default	Description
31-26	R/W	0x0	reserved;
25-0	R/W	0x0	It is used to set the coefficients for attack filter when gain adjusting.

**Table 10-363 EE\_AED\_ND\_CNTL 0x62**

Bits	R/W	Default	Description
31-3	R/W	0x0	reserved;
2-1	R/W	0x0	nd_gain_sel: It is used to set the gain when noise is detected. 0 = 1/2 1 = 1/4 2 = 1/8 3 = 0
0	R/W	0x0	It is used to enable the dc cut module. 1= enable, 0 = bypass.

**Table 10-364 EE\_AED\_MIX0\_LL 0x63**

Bits	R/W	Default	Description
31-26	R/W	0x0	reserved;
25-0	R/W	0x0	It is used to set the ch1 gain to ch1 mixer.

**Table 10-365 EE\_AED\_MIX0\_RL 0x64**

Bits	R/W	Default	Description
31-26	R/W	0x0	reserved;
25-0	R/W	0x0	It is used to set the ch2 gain to ch1 mixer.

**Table 10-366 EE\_AED\_MIX0\_LR 0x65**

Bits	R/W	Default	Description
31-26	R/W	0x0	reserved;
25-0	R/W	0x0	It is used to set the ch1 gain to ch2 mixer.

**Table 10-367 EE\_AED\_MIX0\_RR 0x66**

Bits	R/W	Default	Description
31-26	R/W	0x0	reserved;
25-0	R/W	0x0	It is used to set the ch2 gain to ch2 mixer.

**Table 10-368 EE\_AED\_CLIP\_THD 0x67**

Bits	R/W	Default	Description
31-23	R/W	0x0	reserved;
22-0	R/W	0x0	It is used to set the clipping threshold.

**Table 10-369 EE\_AED\_CH1\_ND\_SUM\_OUT 0x68**

Bits	R/W	Default	Description
31-0	R	0x0	It is used to report the sum of amplitude of ch1.

**Table 10-370 EE\_AED\_CH2\_ND\_SUM\_OUT 0x69**

Bits	R/W	Default	Description
31-0	R	0x0	It is used to report the sum of amplitude of ch2.

**Table 10-371 EE\_AED\_CH1\_ND\_CZ\_OUT 0x6a**

Bits	R/W	Default	Description
31-16	R	0x0	reserved;
15-0	R	0x0	It is used to report the sum of zero-crossing of ch1.

**Table 10-372 EE\_AED\_CH2\_ND\_CZ\_OUT 0x6b**

Bits	R/W	Default	Description
31-16	R	0x0	reserved;
15-0	R	0x0	It is used to report the sum of zero-crossing of ch2.

**Table 10-373 EE\_AED\_NOISE\_STATUS 0x6c**

Bits	R/W	Default	Description
31-7	R	0x0	reserved;
6	R	0x0	It is used to report the noise flag.
5-3	R	0x0	It is used to report the audio state.
2-0	R	0x0	It is used to report the noise state.

**Table 10-374 EE\_AED\_POW\_CURRENT\_S0 0x6d**

Bits	R/W	Default	Description
-	R	0x0	reserved;
31-0	R	0x0	It is used to report the mdrc0 current power.

**Table 10-375 EE\_AED\_POW\_CURRENT\_S1 0x6e**

Bits	R/W	Default	Description
-	R	0x0	reserved;
31-0	R	0x0	It is used to report the mdrc1 current power.

**Table 10-376 EE\_AED\_POW\_CURRENT\_S2 0x6f**

Bits	R/W	Default	Description
-	R	0x0	reserved;
31-0	R	0x0	It is used to report the mdrc2 current power.

**Table 10-377 EE\_AED\_POW\_OUT0 0x70**

Bits	R/W	Default	Description
-	R	0x0	reserved;
31-0	R	0x0	It is used to report the mdrc0 destination power.

**Table 10-378 EE\_AED\_POW\_OUT1 0x71**

Bits	R/W	Default	Description
-	R	0x0	reserved;
31-0	R	0x0	It is used to report the mdrc1 destination power.

**Table 10-379 EE\_AED\_POW\_OUT2 0x72**

Bits	R/W	Default	Description
-	R	0x0	reserved;
31-0	R	0x0	It is used to report the mdrc2 destination power.

**Table 10-380 EE\_AED\_ADJ\_INDEX0 0x73**

Bits	R/W	Default	Description
-	R	0x0	reserved;
31-0	R/W	0x0	It is used to report the mdrc0 adjusting power.

**Table 10-381 EE\_AED\_ADJ\_INDEX1 0x74**

Bits	R/W	Default	Description
-	R	0x0	reserved;
31-0	R	0x0	It is used to report the mdrc1 adjusting power.

**Table 10-382 EE\_AED\_ADJ\_INDEX2 0x75**

Bits	R/W	Default	Description
-	R	0x0	reserved;
31-0	R	0x0	It is used to report the mdrc2 adjusting power.

**Table 10-383 EE\_AED\_DRC\_GAIN\_INDEX0 0x76**

Bits	R/W	Default	Description
31-26	R	0x0	reserved;
25-0	R	0x0	It is used to report mdrc0 the gain.

**Table 10-384 EE\_AED\_DRC\_GAIN\_INDEX1 0x77**

Bits	R/W	Default	Description
31-26	R	0x0	reserved;
25-0	R	0x0	It is used to report mdrc0 the gain.

**Table 10-385 EE\_AED\_DRC\_GAIN\_INDEX2 0x78**

Bits	R/W	Default	Description
31-26	R	0x0	reserved;
25-0	R	0x0	It is used to report mdrc0 the gain.

**Table 10-386 EE\_AED\_CH1\_VOLUME\_STATE 0x79**

Bits	R/W	Default	Description
31-11	R	0x0	reserved;
10-0	R	0x0	It is used to report the volume state of ch1.

**Table 10-387 EE\_AED\_CH2\_VOLUME\_STATE 0x7a**

Bits	R/W	Default	Description
31-11	R	0x0	reserved;
10-0	R	0x0	It is used to report the volume state of ch2.

**Table 10-388 EE\_AED\_CH1\_VOLUME\_GAIN 0x7b**

Bits	R/W	Default	Description
31-25	R	0x0	reserved;
25-0	R	0x0	It is used to report the volume gain of ch1.

**Table 10-389 EE\_AED\_CH2\_VOLUME\_GAIN 0x7c**

Bits	R/W	Default	Description
31-25	R	0x0	reserved;
25-0	R	0x0	It is used to report the volume gain of ch2.

**Table 10-390 EE\_AED\_FULL\_POW\_CURRENT 0x7d**

Bits	R/W	Default	Description
-	R	0x0	reserved;
31-0	R	0x0	It is used to report the current power.

**Table 10-391 EE\_AED\_FULL\_POW\_OUT 0x7e**

Bits	R/W	Default	Description
-	R	0x0	reserved;
31-0	R	0x0	It is used to report the destination power.

**Table 10-392 EE\_AED\_FULL\_POW\_ADJ 0x7f**

Bits	R/W	Default	Description
-	R	0x0	reserved;
31-0	R	0x0	It is used to report the adjusting power.

**Table 10-393 EE\_AED\_FULL\_DRC\_GAIN 0x80**

Bits	R/W	Default	Description
31-26	R	0x0	reserved;
25-0	R	0x0	It is used to report the gain.

Table 10-394 EE\_AED\_MASTER\_VOLUME\_STATE 0x81

Bits	R/W	Default	Description
31-11	R	0x0	reserved;
10-0	R	0x0	It is used to report the volume state of master.

Table 10-395 EE\_AED\_MASTER\_VOLUME\_GAIN 0x82

Bits	R/W	Default	Description
31-26	R	0x0	reserved;
25-0	R	0x0	It is used to report the volume gain of master.

Table 10-396 EE\_AED\_AED\_TOP\_CTL 0x83

Bits	R/W	Default	Description
31	R/W	0x0	reg_start_en: write 1 to start eqdrc function, will auto clear to 0
30	R/W	0x0	reserved;
29-26	R/W	0x0	reg_lane_eq_ch34: eqdrc channel 34 select, can only set one bit valid 0000: audio data to channel 34 will be zero 0001: audio data from lane0 0010: audio data from lane1 0100: audio data from lane2 1000: audio data from lane3
25-18	R/W	0x0	reg_channel_valid: audio channel valid for each bit
17-14	R/W	0x0	reg_lane_eq_ch12: eqdrc channel 12 select, can only set one bit valid 0000: audio data to channel 12 will be zero 0001: audio data from lane0 0010: audio data from lane1 0100: audio data from lane2 1000: audio data from lane3
13-11	R/W	0x0	reg_data_type: 0: split 64bits ddr data to 8 sample, each sample need 8 bits; if bitwidth < 8, left-justified; 1: split 64bits ddr data to 4 sample, each sample need 16 bits; if bitwidth < 16, left-justified; 2: split 64bits ddr data to 4 sample, each sample need 16 bits; if bitwidth < 16, right-justified; 3: split 64bits ddr data to 2 sample, each sample need 32 bits; if bitwidth < 32, left-justified; 4: split 64bits ddr data to 2 sample, each sample need 32 bits; if bitwidth < 32, right-justified;
10-6	R/W	0x0	reg_data_msb: msb position of data
5-4	R/W	0x0	reg_frddr_source: 0: frddr_A; 1: frddr_B; 2: frddr_C;
2	R/W	0x0	reg_affo_in_rst: reset affo in side;
1	R/W	0x0	reg_affo_out_rst: reset affo out side;
0	R/W	0x0	req_eqdrc_en: eqdrc module enable

Table 10-397 EE\_AED\_AED\_TOP\_CTL 0x84

Bits	R/W	Default	Description
31-20	R/W	0x0	reserved;
19-12	R/W	0x0	reg_ack_num: if needn't share buffer, set it as 0; if need share buffer , set it as TDMOUT/SPDIFOUT ch number;
11	R/W	0x0	reg_req_sel2_en
10-8	R/W	0x0	reg_req_sel2: 0: tdmout_a; 1: tdmout_b; 2: tdmout_c; 3: spdifout; 4: spdifout_b; 5: reserved; 6: reserved; 7: reserved;
7	R/W	0x0	reg_req_sel1_en
6-4	R/W	0x0	reg_req_sel1: 0: tdmout_a; 1: tdmout_b; 2: tdmout_c; 3: spdifout; 4: spdifout_b; 5: reserved; 6: reserved; 7: reserved;
3	R/W	0x0	reg_req_sel0_en
2-0	R/W	0x0	req_req_sel0: 0: tdmout_a; 1: tdmout_b; 2: tdmout_c; 3: spdifout; 4: spdifout_b; 5: reserved; 6: reserved; 7: reserved;

# 11 AFIFO

## 11.1 Register Description

Base address: 0xffd05000

**Table 11-1 AIU\_AIFIFO\_CTRL 0x00**

Bit(s)	R/W	Default	Description
13	R/W	0	Aififo request to dcu status
12	R/W	0	Dcu select status
11:5	R/W	0	Aififo word counter number
4:0	R/W	0	How many bits left in the first pop register

**Table 11-2 AIU\_AIFIFO\_STATUS 0x01**

Bit(s)	R/W	Default	Description
4:0	R	0x0	How many Bits left in the first pop register

**Table 11-3 AIU\_AIFIFO\_GBIT 0x02**

Bit(s)	R/W	Default	Description
15:0	R	0x0	The gb data

**Table 11-4 AIU\_AIFIFO\_CLB 0x03**

Bit(s)	R/W	Default	Description
15:0	R	0x0	The gb data

**Table 11-5 AIU\_MEM\_AIFIFO\_START\_PTR 0x04**

Bit(s)	R/W	Default	Description
31:0	RW	0x0	The start address from DDR

**Table 11-6 AIU\_MEM\_AIFIFO\_CURR\_PTR 0x05**

Bit(s)	R/W	Default	Description
31:0	R	0x0	The current address from DDR

**Table 11-7 AIU\_MEM\_AIFIFO\_END\_PTR 0x06**

Bit(s)	R/W	Default	Description
31:0	RW	0x0	The end address from DDR



**Table 11-8 AIU\_MEM\_AIFIFO\_BYTES\_AVAIL 0x07**

Bit(s)	R/W	Default	Description
15:11	R/W	0	Unused.
10	R/W	0	Set this bit to 1 to enable filling of the FIFO controlled by the buffer level control. If this bit is 0, then use bit[1] to control the enabling of filling
9	R/W	0	This bit is set when data can be popped
8	R/W	0	This bit will be high when we're fetching data from the DDR memory To reset this module, set cntl_enable = 0, and then wait for busy = 0. After that you can pulse cntl_init to start over
7	R/W	0	Just in case endian. last minute byte swap of the data out of the FIFO to getbit
6	R/W	0	Unused.
5:3	R/W	0	
2	R/W	0	Set to 1 to enable reading the DDR memory FIFO and filling the pipeline to get-bit Set cntl_empty_en = cntl_fill_en = 0 when pulsing cntl_init
1	R/W	0	Set to 1 to enable reading data from DDR memory
0	R/W	0	After setting the read pointers, sizes, channel masks and read masks, set this bit to 1 and then to 0 NOTE: You don't need to pulse cntl_init if only the start address is being changed

**Table 11-9 AIU\_MEM\_AIFIFO\_CONTROL 0x08**

Bit(s)	R/W	Default	Description
15:11		0x0	Unused
10	RW	0x0	Use_level Set This bit to 1 to enable filling of the FIFO controlled by the buffer level control. If This bit is 0, then use Bit[1] to control the enabling of filling
9	RW	0x0	Data Ready. This bit is set when data can be popped
8	RW	0x0	Fill busy This bit will be high when we're fetching data from the DDR memory
7	RW	0x0	Cntl_endian_jic Just in case endian. Last minute byte swap of the data out of the FIFO to get bit
6	RW	0x0	Unused
5:3	RW	0x0	Endian
2	RW	0x0	Cntl_empty_en Set to 1 to enable reading the DDR memory FIFO and filling the pipeline to get-bit
1	RW	0x0	Cntl_fill_en Set to 1 to enable reading data from DDR memory
0	RW	0x0	Cntl_init

**Table 11-10 AIU\_MEM\_AIFIFO\_MAN\_WP 0x09**

Bit(s)	R/W	Default	Description
31:0	RW	0x0	Manual write ptr.

Table 11-11 AIU\_MEM\_AIFIFO\_MAN\_RP 0x0a

Bit(s)	R/W	Default	Description
31:0	RW	0x0	Manual read ptr.

Table 11-12 AIU\_MEM\_AIFIFO\_LEVEL 0x0b

Bit(s)	R/W	Default	Description
1	R/W	0	Set to 1 for manual write pointer mode
0	R/W	0	Set high then low after everything has been initialized

Table 11-13 AIU\_MEM\_AIFIFO\_BUF\_CNTL 0x0c

Bit(s)	R/W	Default	Description
1	RW	0x0	manual mode Set to 1 for manual write pointer mode
0	RW	0x0	Init Set high then low after everything has been initialized

Table 11-14 AIU\_MEM\_AIFIFO\_BUF\_WRAP\_COUNT 0x0d

Bit(s)	R/W	Default	Description
29:24	R/W	0	A_brst_num
21:16	R/W	0	A_id
15:0	R/W	0	level_hold

Table 11-15 AIU\_MEM\_AIFIFO\_MEM\_CTL 0x0f

Bit(s)	R/W	Default	Description
31:16	R/W	0	drop_bytes
15:14	R/W	0	drop_status (Read-Only)
13:12	R/W	0	sync_match_position (Read-Only)
11:6	R/W	0	reserved
5:4	R/W	0	TIME_STAMP_NUMBER, 0-32bits, 1-64bits, 2-96bits, 3-128bits
3	R/W	0	stamp_soft_reset
2	R/W	0	TIME_STAMP_length_enable
1	R/W	0	TIME_STAMP_sync64_enable
0	R/W	0	TIME_STAMP_enable

Table 11-16 AIFIFO\_TIME\_STAMP\_CNTL 0x10

Bit(s)	R/W	Default	Description
31:0	R/W	0	TIME_STAMP_SYNC_CODE_0

**Table 11-17 AIFIFO\_TIME\_STAMP\_SYNC\_0 0x11**

Bit(s)	R/W	Default	Description
31:0	R/W	0	TIME_STAMP_SYNC_CODE_1

**Table 11-18 AIFIFO\_TIME\_STAMP\_SYNC\_1 0x12**

Bit(s)	R/W	Default	Description
31:0	R/W	0	TIME_STAMP_0

**Table 11-19 AIFIFO\_TIME\_STAMP\_0 0x13**

Bit(s)	R/W	Default	Description
31:0	R/W	0	TIME_STAMP_1

**Table 11-20 AIFIFO\_TIME\_STAMP\_1 0x14**

Bit(s)	R/W	Default	Description
31:0	R/W	0	TIME_STAMP_2

**Table 11-21 AIFIFO\_TIME\_STAMP\_2 0x15**

Bit(s)	R/W	Default	Description
31:0	R/W	0	TIME_STAMP_3

**Table 11-22 AIFIFO\_TIME\_STAMP\_3 0x16**

Bit(s)	R/W	Default	Description
31:0	R/W	0	TIME_STAMP_LENGTH

**Table 11-23 AIFIFO\_TIME\_STAMP\_LENGTH 0x17**

Bit(s)	R/W	Default	Description
31:0	R/W	0x0	TIME_STAMP_LENGTH

# 12 Memory Interface

This chapter describes the SoC's memory interfaces from the following aspects:

- DDR
- NAND
- EMMC/SDIO/SD
- SPICC
- SPIFC

## 12.1 DDR

### 12.1.1 Overview

DDR consists of the 2 parts: DDR memory controller (DMC) and DDR PHY controller. The main features of this module are listed below:

- Support DDR3/4 SDRAM, LPDDR3, LPDDR4 SDRAM
- Support 32bits and 16bits data mode.
- Unbalanced 16bits DDR3/4 SDRAM size in 32 bits data bus mode.
- Each DDR command buffer contains 64bytes data.
- 32 write command buffer and 32 read command buffer for DDR command generation.
- READ command reordering regardless ID.
- Write command reordering regardless IDs.
- Write and read data coherence.
- Optimized DDR command reordering based on:
  - Priority
  - Rank
  - Bank
  - Bank group interleaving(DDR4)
  - Read/write
- 4 level priority control to reduce the latency for the urgent request.
- Unblocking urgent control through Asynchronous FIFO and pipelines.
- Additional 128 depth write data FIFO to balance DMC and AXI master write throughputs.
- Additional 128\*128 read data FIFO to balance DMC and AXI master read throughputs.
- Per Port Per ID Security Control through the all security ranges.
- Up to 16 security range can be defined.
- Support up to 16 AXI3/4 and 8 AMBUS(Amlogic) interfaces.
- Optimized AMBUS to support 0~3 burst to improve DDR efficiency and reduce
- Low power control with LPDDR4 Multi-PHY V2.
  - Adding auto Self-Refresh mode for super low bandwidth application.
  - Auto power down mode for most of application.
  - Hardware Fast Frequency change less than 10uS.

Figure 12-1 DDR Interface

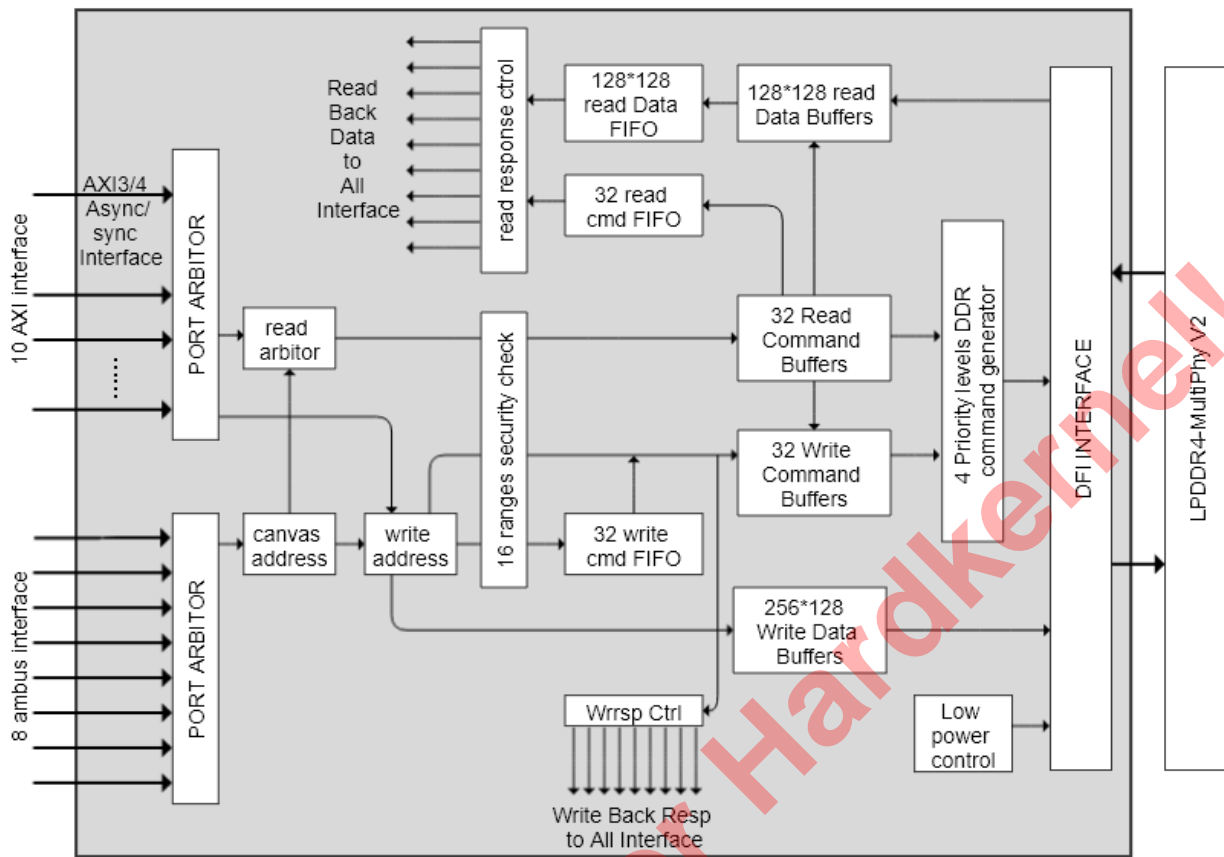

### 12.1.2 Register Description

DMC insecure register. Base address 0xFF638000. Each register takes 4 byte address.

Each register's final address = 0xFF638000+ offset \* 4.

Table 12-1 AM\_DDR\_PLL\_CNTL 0 0x0000

Bit(s)	R/W	Default	Description
29			dpll_reset.
28			dpll_en.
27:26			dpll_clk_en
20:19			od1
18:16			od
14:10			dpll_ref_div_n
8:0			dpll_int_num

Table 12-2 AM\_DDR\_PLL\_CNTL1 0x0001

Bit(s)	R/W	Default	Description
18:0			ddr_dpll_frac

Table 12-3 AM\_DDR\_PLL\_CNTL2 0x0002

Bit(s)	R/W	Default	Description
22:20			fref_sel
17:16			os_ssc
15:12			ssc_str_m
8			ssc_en
7:4			ssc_dep_sel
1:0			dpll ss_mode

Table 12-4 AM\_DDR\_PLL\_CNTL3 0x0003

Bit(s)	R/W	Default	Description
31			afc bypass
30			afc clk sel
29			code new
28			dco_m_en
27			dco_sdm_en
26			div2
25			div mode
24			fast_lock mode
23			fb_pre_div
22			filter_mode
21			fix_en
20			freq_shift_en
19			load
18			load_en
17			lock_f
16			pulse_width_en
15			sdmnc_en
14			sdmnc_mode
13			sdmnc_range
12			tdc_en

Bit(s)	R/W	Default	Description
11			tdc_mode_sel
10			wait_en

Table 12-5 AM\_DDR\_PLL\_CNTL4 0x0004

Bit(s)	R/W	Default	Description
1:0			pdf_gain
7:4			filter_pvt1
11:8			filter pvt2
13:12			acq_gain
18:16			lambda0
22:20			lambda1
26:24			rou
30:28			alpha

Table 12-6 AM\_DDR\_PLL\_CNTL5 0x0005

Bit(s)	R/W	Default	Description
15:0			reve
21:16			lm_s
27:24			lm_w
30:28			adj_vco_ldo

Table 12-7 AM\_DDR\_PLL\_CNTL6 0x0006

Bit(s)	R/W	Default	Description
15:0			reve
21:16			lm_s
27:24			lm_w
30:28			adj_vco_ldo

Table 12-8 AM\_DDR\_PLL\_STS 0x0007

Bit(s)	R/W	Default	Description
31			DDR_PLL_LOCK
30:19			not used
18			DDR_AFC_DONE
17			DDR_PLL_LOCK

Bit(s)	R/W	Default	Description
16:7			DDR_DPLL_OUT_RSV
6:0			DDR_SDMNC_MONITOR

**Table 12-9 DDR\_CLK\_CNTL 0x0008**

Bit(s)	R/W	Default	Description
31			ddr_pll_clk enable. enable the clock from DDR_PLL to clock generation.
30			ddr_pll_prod_test_en. enable the clock to clock/32 which to clock frequency measurement and production test pin.
29			not used.
28			clock generation logic soft reset. 0 = reset.
27			phy_4xclk phase inverter
26			pll_freq divide/2. 1: use pll div/2 clock as the n_clk. 0: use pll clock as n_clk. this setting is used for the DDR PHY PLL fast lock mode.
2			enable dmc_clk.
1			enable LPDDR4-PHY DfIClk.
0			enable LPDDR4-PHY DfICtIClk.

**Table 12-10 DDR\_PHY\_CTRL 0x0009**

Bit(s)	R/W	Default	Description
4			DDR PHY PwrOkIn pin.
1			DDR PHY APB soft reset_n.
0			phy_reset_n.

**Table 12-11 AM\_DDR\_PLL\_FREQ1\_OD 0x000c**

Bit(s)	R/W	Default	Description
8			currunt FREQ selection. it can forced to change to select which frequency to select, or it can auto changed by FREQ change hardware.
5:4			OD1.
2:0			OD.

The following registers' base address is 0xff638000. Each register takes 4 byte address.

Each register's final address = 0xff638000 + offset \* 4.

**Table 12-12 DMC\_REQ\_CTRL 0x0000**

Bit(s)	R/W	Default	Description
23			enable dmc request of ambus chan 7. Reserved for GE2D interface. Async interface.
22			enable dmc request of ambus chan 6. DOS HCODEC interface Sync interface.



Bit(s)	R/W	Default	Description
21			enable dmc request of ambus chan 5. DOS VDEC interface Sync interface.
20			enable dmc request of ambus chan 4. VPU write interface 1 Sync interface.
19			enable dmc request of ambus chan 3. VPU write interface 0 Sync interface.
18			enable dmc request of ambus chan 2. VPU read interface 2. Sync interface.
17			enable dmc request of ambus chan 1. VPU read interface 1. Sync interface.
16			enable dmc request of ambus chan 0. VPU read interface 0. Sync interface.
10			NNA enable/disable bit
9			enable dmc request of axibus chan 9. wave async interface.
8			enable dmc request of axibus chan 8 hevc_b async interface.
7			enable dmc request of axibus chan 7. DEVICE. Async interface.
6			enable dmc request of axibus chan 6. USB Async interface.
5			enable dmc request of axibus chan 5. reserved for dmc_test.
4			enable dmc request of axibus chan 4. hevc front Async interface.
3			enable dmc request of axibus chan 3. HDCP/HDMI Async interface.
2			enable dmc request of axibus chan 2. pcie async
1			enable dmc request of axibus chan 1. Dvalin . async interface.
0			enable dmc request of axibus chan 0. CPU/A53 async interface.

Table 12-13 DMC\_SOFT\_RST 0x0001

Bit(s)	R/W	Default	Description
31:24			Reserved.
23:16			8 AMBUS input interface n_clk domain reset_n signal. 0 : reset. 1: normal working mode.
15:0			16 AXI BUS input interfaces n_clk domain reset_n signal. 0: reset. 1: normal working mode. each bit for one interface.

Table 12-14 DMC\_SOFT\_RST1 0x0002

Bit(s)	R/W	Default	Description
31:24			Not used.
23:16			8 am bus interfaces master clock domain reset_n signal. 0 : reset : 1 normal working mode.
15:0.			16 AXI bus interfaces master clock domain reset_n signal. 0 : reset : 1 normal working mode.

**Table 12-15 DMC\_SOFT\_RST2 0x0003**

Bit(s)	R/W	Default	Description
31~11			Reserved.
10			DMC DFI cmd soft reset_n
9			DMC DFI MISC soft reset_n
8			DMC DFI data soft reset_n
7			DMC DFI dcu soft reset_n
6			DMC siu soft reset_n
5			DMC test soft reset_n. 0 : reset. 1 : normal working mode.
4			DMC low power control module soft reset_n. 0 : reset. 1 : normal working mode.
3			DMC QOS monitor module soft reset_n. 0 : reset. 1 : normal working mode.
2			DMC register module soft reset_n. 0 : reset. 1 : normal working mode.
1			DMC canvas transfer module soft reset_n. 0 : reset. 1 : normal working mode.
0			DMC command buffers and command generation modules soft reset. 0 = reset. 1:

**Table 12-16 DMC\_RST\_STS1 0x0004**

Bit(s)	R/W	Default	Description
31:24			Not used.
23:0			Read only. The DMC_SOFT_RST1 signal in n_clk domain. When one of the 2 clocks is too slow or too fast, we can read this register to make sure another clock domain reset is done.

DMC\_VERSION 0x0005

DMC version number.

DC\_CAV\_LUT\_DATA1 0x0012

low 32 bits of canvas data which need to be configured to canvas memory.

**Table 12-17 DC\_CAV\_LUT\_DATAH 0x0013**

Bit(s)	R/W	Default	Description
60:58			Canvas block mode. 2: 64x32, 1: 32x32; 0: linear mode.
57:56			canvas Y direction wrap control. 1: wrap back in y. 0: not wrap back.
55			canvas X direction wrap control. 1: wrap back in X. 0: not wrap back.
54			canvas Height.
53:41			canvas Width, unit: 8 bytes. must in 32 bytes boundary. that means last 2 bits must be 0.
40:29			canvas start address. unit. 8 bytes. must be in 32 bytes boundary. that means last 2 bits must be 0.
28:0			Canvas block mode. 2 : 64x32, 1: 32x32; 0 : linear mode.

**Table 12-18 DC\_CAV\_LUT\_ADDR 0x0014**

Bit(s)	R/W	Default	Description
9:8			Write 9:8 2'b10. the canvas data will saved in canvas memory with address 7:0.
7:0			256 canvas Look up table address.

DC\_CAV\_LUT\_RDATAL 0x0015

CBUS low 32bytes canvas read back data from LUT.

DC\_CAV\_LUT\_RDATAH 0x0016

CBUS low 32bytes canvas read back data from LUT.

**Table 12-19 DC\_CAV\_BLK\_CTRL0 0x0018**

Bit(s)	R/W	Default	Description
31:0			blkmode. 1 : 32x32. 0 : others.

**Table 12-20 DC\_CAV\_BLK\_CTRL1 0x0019**

Bit(s)	R/W	Default	Description
63:32			blkmode. 1 : 32x32. 0 : others.

**Table 12-21 DC\_CAV\_BLK\_CTRL2 0x001a**

Bit(s)	R/W	Default	Description
95:64			blkmode. 1 : 32x32. 0 : others.

**Table 12-22 DC\_CAV\_BLK\_CTRL3 0x001b**

Bit(s)	R/W	Default	Description
127:96			blkmode. 1 : 32x32. 0 : others.

**Table 12-23 DC\_CAV\_BLK\_CTRL4 0x001c**

Bit(s)	R/W	Default	Description
159:128			blkmode. 1 : 32x32. 0 : others.

**Table 12-24 DC\_CAV\_BLK\_CTRL5 0x001d**

Bit(s)	R/W	Default	Description
191:160			blkmode. 1 : 32x32. 0 : others.

**Table 12-25 DC\_CAV\_BLK\_CTRL6 0x001e**

Bit(s)	R/W	Default	Description
223:192			blkmode. 1 : 32x32. 0 : others.

**Table 12-26 DC\_CAV\_BLK\_CTRL7 0x001f**

Bit(s)	R/W	Default	Description
255:224			blkmode. 1 : 32x32. 0 : others.

**Table 12-27 DMC\_MON\_CTRL0 0x0020**

Bit(s)	R/W	Default	Description
31			qos_mon_en. write 1 to trigger the enable. polling this bit 0, means finished. or use interrupt to check finish.
30			qos_mon interrupt clear. clear the qos monitor result. read 1 = qos mon finish interrupt.
3			qos monitor 3 enable.
2			qos monitor 2 enable.
1			qos monitor 1 enable.
0			qos monitor 0 enable.

**Table 12-28 DMC\_MON\_CTRL1 0x0021**

Bit(s)	R/W	Default	Description
23:0			qos monitor 0 channel select. 8 ambus port and 16 AXI port selection. 1 bit for one port.

**Table 12-29 DMC\_MON\_CTRL2 0x0022**

Bit(s)	R/W	Default	Description
15:0			port select for the selected channel.

**Table 12-30 DMC\_MON\_CTRL3 0x0023**

Bit(s)	R/W	Default	Description
23:0			qos monitor 0 channel select. 8 ambus port and 16 AXI port selection. 1 bit for one port.

**Table 12-31 DMC\_MON\_CTRL4 0x0024**

Bit(s)	R/W	Default	Description
15:0			port select for the selected channel.

**Table 12-32 DMC\_MON\_CTRL5 0x0025**

Bit(s)	R/W	Default	Description
23:0			qos monitor 0 channel select. 8 ambus port and 16 AXI port selection. 1 bit for one port.

**Table 12-33 DMC\_MON\_CTRL6 0x0026**

Bit(s)	R/W	Default	Description
15:0			port select for the selected channel.

**Table 12-34 DMC\_MON\_CTRL7 0x0027**

Bit(s)	R/W	Default	Description
23:0			port select for the selected channel.

**Table 12-35 DMC\_MON\_CTRL8 0x0028**

Bit(s)	R/W	Default	Description
15:0			port select for the selected channel.

DMC\_MON\_ALL\_REQ\_CNT 0x0029

At the test period, the whole MMC request time.

DMC\_MON\_ALL\_GRANT\_CNT 0x002a

At the test period, the whole MMC granted data cycles. 64 bits unit.

DMC\_MON\_ONE\_GRANT\_CNT 0x002b

At the test period, the granted data cycles for the selected channel and ports.

DMC\_MON\_SEC\_GRANT\_CNT 0x002c

At the test period, the granted data cycles for the selected channel and ports.

DMC\_MON\_THD\_GRANT\_CNT 0x002d

At the test period, the granted data cycles for the selected channel and ports.

DMC\_MON\_FOR\_GRANT\_CNT 0x002e

At the test period, the granted data cycles for the selected channel and ports.

DMC\_MON\_TIMER 0x002f

Timer for the monitor period.

**Table 12-36 DMC\_CLKG\_CTRL0 0x0030**

Bit(s)	R/W	Default	Description
23:16			Enable the 8 ambus interfaces both main and n_clk auto clock gating function. each 1 bit for one interface.
15:0			Enable the 16 axi interfaces both main and n_clk auto clock gating function. each 1 bit for one interface.

**Table 12-37 DMC\_CLKG\_CTRL1 0x0031**

Bit(s)	R/W	Default	Description
23:16			Force to disable the 8 ambus interfaces both main and n_clk. each 1 bit for one interface.
15:0			Force to disable the 16 axi interfaces both main and n_clk. each 1 bit for one interface.

**Table 12-38 DMC\_CLKG\_CTRL2 0x0032**

Bit(s)	R/W	Default	Description
7			Force to disable the clock of write rsp generation.
6			Force to disable the clock of read rsp generation.
5			Force to disable the clock of command filter.
4			Force to disable the clock of write reorder buffer.
3			Force to disable the clock of write data buffer.
2			Force to disable the clock of read reorder buffer.
1			Force to disable the clock of read canvas.
0			Force to disable the clock of write canvas.

**Table 12-39 DMC\_CLKG\_CTRL3 0x0033**

Bit(s)	R/W	Default	Description
7			Enable auto clock gating for write rsp generation.
6			Enable auto clock gating for read rsp generation.
5			Enable auto clock gating for ddr0 command filter.
4			Enable auto clock gating for ddr0 write reorder buffer.
3			Enable auto clock gating for ddr0 write data buffer.
2			Enable auto clock gating for ddr0 read reorder buffer.
1			Enable auto clock gating for read canvas.
0			Enable auto clock gating for write canvas.

**Table 12-40 DMC\_CHAN\_STS 0x0036**

Bit(s)	R/W	Default	Description
31:28RO	RO		Not used.
27 RO	RO		always 1
26 RO	RO		ddr0 write data buffer idle. 1 : idle 0: busy.
25 RO	RO		always 1.
24 RO	RO		ddr0 wbuf idle. 1 : idle 0: busy.

Bit(s)	R/W	Default	Description
23:16	RO		ambus channel idle. 1 : idle 0: busy.
15:0	RO		axibus channel idle. 1 : idle 0: busy.

**Table 12-41 DMC\_2ARB\_CTRL 0x0038**

Bit(s)	R/W	Default	Description
32:24			Not used.
22.			always 1
21:12			ddr0 write data buffer idle. 1 : idle 0: busy.
11:6.			always 1.
5:0.			ddr0 wbuf idle. 1 : idle 0: busy.

**Table 12-42 DMC\_CMD\_FILTER\_CTRL1 0x0040**

Bit(s)	R/W	Default	Description
30			1 : use DDR4 special filter.

DMC\_CMD\_FILTER\_CTRL2 0x0041

Not used.

**Table 12-43 DMC\_CMD\_FILTER\_CTRL3 0x0042**

Bit(s)	R/W	Default	Description
31.			force wbuf empty.
30:26			wbuf high level number
25:21			wbuf mid level number
20:16			wbuf low level number
14:10			rbuf high level number
9:5			rbuf middle level number
4:0			rbuf low level number

**Table 12-44 DMC\_CMD\_FILTER\_CTRL4 0x0043**

Bit(s)	R/W	Default	Description
29:25			tITW.long
24:20			tITW. short
19:12			tAP auto precharge the bank not used if idle that long time.
11:6			write to read accesses if there write hit request.
5:0			read to write accesses if there write hit request.

**Table 12-45 DMC\_CMD\_FILTER\_CTRL5 0x0044**

Bit(s)	R/W	Default	Description
31:24			Once ddr data bus switch to read, the maximum read command number to give up the bus when there's write request pending for write buffer.
23:16			Once ddr data bus switch to write, the maximum write command number to give up the bus when there's read request pending too long.
15:8			Once ddr data bus switch to read, the minimum read command number to transfer back to write stage if there's still pending read request.
7:0			Once ddr data bus switch to write, the minimum write command number to transfer back to read stage if there's still pending write request.

**Table 12-46 DMC\_CMD\_BUFFER\_CTRL 0x0045**

Bit(s)	R/W	Default	Description
31:26			Total write buffer number. Default 32.
25:20			Total read buffer number. Default 32.
19:8			Reserved
7:0			aw_pending_inc_num. increase write urgent level 1 when write command waiting to in write buffer that long.

**Table 12-47 DMC\_CMD\_BUFFER\_CTRL1 0x0046**

Bit(s)	R/W	Default	Description
31:26			Read buffer number in non-urgent request.
25:20			Read buffer bank miss watch dog threshold.
19:8			Read buffer urgent level 3 counter inc weight.
7:0			Read buffer urgent level 2 counter inc weight.
3:0			Read buffer urgent level 2 counter inc weight.

**Table 12-48 DMC\_CMD\_FILTER\_CTRL6 0x0047**

Bit(s)	R/W	Default	Description
31:24			write urgent 3 request pending hold num.
23:16			write urgent 2 request pending hold num.
15:8			write urgent 1 request pending hold num.
7:0			write urgent 0 request pending hold num.

DMC\_RDDBUF\_CTRL 0x0048

Not used.



**Table 12-49 DMC\_CMD\_FILTER\_CTRL7 0x0049**

Bit(s)	R/W	Default	Description
15:8			Write to read waiting cycles if there write hit request.
7:0			Read to write waiting cycles if there write hit request.

**Table 12-50 DMC\_AM0\_CHAN\_CTRL 0x0060**

Bit(s)	R/W	Default	Description
31			Enable to incr 2 urgent levels if the pending cycles is doubled.
30			Enable to incr 3 urgent levels.
29:20			Write request pending cycle number to inc urgent level if not granted.
18.			Force this channel all request to be super urgent request.
17.			Force this channel all request to be urgent request.
16.			Force this channel all request to be non-urgent request.
13:4.			Read request pending cycle number to inc urgent level if not granted.
3:0			Canvas arbiter weight

**Table 12-51 DMC\_AM0\_HOLD\_CTRL 0x0061**

Bit(s)	R/W	Default	Description
15:8			Read hold num. Max outstanding request number.
7:0			Read hold release num. If the outstanding request == hold num, then hold this request unless the outstanding request number below the hold release number, then continue to request.

**Table 12-52 DMC\_AM0\_CHAN\_CTRL1 0x0062**

Bit(s)	R/W	Default	Description
31			Side band signal used as block other request.
30			Side band urgent increase enable.
29			Side band urgent decrease urgent enable.
23:16			When bit 31 enabled, block the ambus related bits read request.
15:0			When bit 31 enabled, block the axi bus related bits read request.

**Table 12-53 DMC\_AM0\_CHAN\_CTRL2 0x0063**

Bit(s)	R/W	Default	Description
31:24			Not used.
23:16			When side band signal used as block other request, and side bank signal is high, block the ambus related bits write request.
15:0			When side band signal used as block other request, and side bank signal is high, block the axi bus related bits write request.

Table 12-54 DMC\_AM1\_CHAN\_CTRL 0x0064

Bit(s)	R/W	Default	Description
31			Enable to incr 2 urgent levels if the pending cycles is doubled.
30			Enable to incr 3 urgent levels.
29:20			Write request pending cycle number to inc urgent level if not granted.
18.			Force this channel all request to be super urgent request.
17.			Force this channel all request to be urgent request.
16.			Force this channel all request to be non urgent request.
13:4.			Read request pending cycle number to inc urgent level if not granted.
3:0			Canvas arbiter weight

Table 12-55 DMC\_AM1\_HOLD\_CTRL 0x0065

Bit(s)	R/W	Default	Description
15:8			Read hold num. Max outstanding request number.
7:0			Read hold release num. If the outstanding request == hold num, then hold this request unless the outstanding request number below the hold release number, then continue to request.

Table 12-56 DMC\_AM1\_CHAN\_CTRL1 0x0066

Bit(s)	R/W	Default	Description
31:			Side band signal used as block other request.
30 :			Side band urgent increase enable.
29 :			Side band urgent decrease urgent enable.
23:16			When bit 31 enabled, block the ambus related bits read request.
15:0			When bit 31 enabled, block the axi bus related bits read request.

Table 12-57 DMC\_AM1\_CHAN\_CTRL2 0x0067

Bit(s)	R/W	Default	Description
31:24			Not used.
23:16			When side band signal used as block other request, and side bank signal is high, block the ambus related bits write request.
15:0			When side band signal used as block other request, and side bank signal is high, block the axi bus related bits write request.

**Table 12-58 DMC\_AM2\_CHAN\_CTRL 0x0068**

Bit(s)	R/W	Default	Description
31			Enable to incr 2 urgent levels if the pending cycles is doubled.
30			Enable to incr 3 urgent levels.
29:20			Write request pending cycle number to inc urgent level if not granted.
18.			Force this channel all request to be super urgent request.
17.			Force this channel all request to be urgent request.
16.			Force this channel all request to be non urgent request.
13:4.			Read request pending cycle number to inc urgent level if not granted.
3:0			Canvas arbiter weight

**Table 12-59 DMC\_AM2\_HOLD\_CTRL 0x0069**

Bit(s)	R/W	Default	Description
15:8			Read hold num. Max outstanding request number.
7:0			Read hold release num. If the outstanding request == hold num, then hold this request unless the outstanding request number below the hold release number, then continue to request.

**Table 12-60 DMC\_AM2\_CHAN\_CTRL1 0x006a**

Bit(s)	R/W	Default	Description
31:			Side band signal used as block other request.
30 :			Side band urgent increase enable.
29 :			Side band urgent decrease urgent enable.
23:16			When bit 31 enabled, block the ambus related bits read request.
15:0			When bit 31 enabled, block the axi bus related bits read request.

**Table 12-61 DMC\_AM2\_CHAN\_CTRL1 0x006b**

Bit(s)	R/W	Default	Description
31:24			Not used.
23:16			When side band signal used as block other request, and side bank signal is high, block the ambus related bits write request.
15:0			When side band signal used as block other request, and side bank signal is high, block the axi bus related bits write request.

**Table 12-62 DMC\_AM3\_CHAN\_CTRL 0x006c**

Bit(s)	R/W	Default	Description
31			Enable to incr 2 urgent levels if the pending cycles is doubled.
30			Enable to incr 3 urgent levels.
29:20			Write request pending cycle number to inc urgent level if not granted.
18.			Force this channel all request to be super urgent request.
17.			Force this channel all request to be urgent request.
16.			Force this channel all request to be non urgent request.
13:4.			Read request pending cycle number to inc urgent level if not granted.
3:0			Canvas arbiter weight

**Table 12-63 DMC\_AM3\_HOLD\_CTRL 0x006d**

Bit(s)	R/W	Default	Description
31:24			Write hold num. Max outstanding request number.
23:16			Write hold release num. If the outstanding request == hold num, then hold this request unless the outstanding request number below the hold release number, then continue to request.

**Table 12-64 DMC\_AM3\_CHAN\_CTRL1 0x006e**

Bit(s)	R/W	Default	Description
31			Side band signal used as block other request.
30			Side band urgent increase enable.
29			Side band urgent decrease urgent enable.
23:16			When bit 31 enabled, block the ambus related bits read request.
15:0			When bit 31 enabled, block the axi bus related bits read request.

**Table 12-65 DMC\_AM3\_CHAN\_CTRL2 0x006f**

Bit(s)	R/W	Default	Description
31:24			Not used.
23:16			When side band signal used as block other request, and side bank signal is high, block the ambus related bits write request.
15:0			When side band signal used as block other request, and side bank signal is high, block the axi bus related bits write request.

**Table 12-66 DMC\_AM4\_CHAN\_CTRL 0x0070**

Bit(s)	R/W	Default	Description
31			Enable to incr 2 urgent levels if the pending cycles is doubled.
30			Enable to incr 3 urgent levels.
29:20			Write request pending cycle number to inc urgent level if not granted.
18.			Force this channel all request to be super urgent request.
17.			Force this channel all request to be urgent request.
16.			Force this channel all request to be non urgent request.
13:4.			Read request pending cycle number to inc urgent level if not granted.
3:0			Canvas arbiter weight

**Table 12-67 DMC\_AM4\_HOLD\_CTRL 0x0071**

Bit(s)	R/W	Default	Description
31:24			Write hold num. Max outstanding request number.
23:16			Write hold release num. If the outstanding request == hold num, then hold this request unless the outstanding request number below the hold release number, then continue to request.

**Table 12-68 DMC\_AM4\_CHAN\_CTRL1 0x0072**

Bit(s)	R/W	Default	Description
31:			Side band signal used as block other request.
30 :			Side band urgent increase enable.
29 :			Side band urgent decrease urgent enable.
23:16			When bit 31 enabled, block the ambus related bits read request.
15:0			When bit 31 enabled, block the axi bus related bits read request.

**Table 12-69 DMC\_AM4\_CHAN\_CTRL2 0x0073**

Bit(s)	R/W	Default	Description
31:24			Not used.
23:16			When bit 31 enabled, block the ambus related bits write request.
15:0			When bit 31 enabled, block the axi bus related bits write request.

**Table 12-70 DMC\_AM5\_CHAN\_CTRL 0x0074**

Bit(s)	R/W	Default	Description
31			Enable to incr 2 urgent levels if the pending cycles is doubled.
30			Enable to incr 3 urgent levels.

Bit(s)	R/W	Default	Description
29:20			Write request pending cycle number to inc urgent level if not granted.
18.			Force this channel all request to be super urgent request.
17.			Force this channel all request to be urgent request.
16.			Force this channel all request to be non urgent request.
13:4.			Read request pending cycle number to inc urgent level if not granted.
3:0			Canvas arbiter weight

Table 12-71 DMC\_AM5\_HOLD\_CTRL 0x0075

Bit(s)	R/W	Default	Description
31:24			Write hold num. max outstanding request number.
23:16			Write hold release num. if the outstanding request == hold num, then hold this request unless the outstanding request number below the hold release number, then continue to request.
15:8			Read hold num. max outstanding request number.
7:0			Read hold release num. if the outstanding request == hold num, then hold this request unless the outstanding request number below the hold release number, then continue to request.

Table 12-72 DMC\_AM6\_CHAN\_CTRL 0x0078

Bit(s)	R/W	Default	Description
31			Enable to incr 2 urgent levels if the pending cycles is doubled.
30			Enable to incr 3 urgent levels.
29:20			Write request pending cycle number to inc urgent level if not granted.
18			Force this channel all request to be super urgent request.
17			Force this channel all request to be urgent request.
16			Force this channel all request to be non urgent request.
13:4			Read request pending cycle number to inc urgent level if not granted.
3:0			Canvas arbiter weight

Table 12-73 DMC\_AM6\_HOLD\_CTRL 0x0079

Bit(s)	R/W	Default	Description
31:24			Enable to incr 2 urgent levels if the pending cycles is doubled.
23:16			Enable to incr 3 urgent levels.
15:8			Write request pending cycle number to inc urgent level if not granted.
7:0			Force this channel all request to be super urgent request.

**Table 12-74 DMC\_AM7\_CHAN\_CTRL 0x007c**

Bit(s)	R/W	Default	Description
31			Enable to incr 2 urgent levels if the pending cycles is doubled.
30			Enable to incr 3 urgent levels.
29:20			Write request pending cycle number to inc urgent level if not granted.
18.			Force this channel all request to be super urgent request.
17.			Force this channel all request to be urgent request.
16.			Force this channel all request to be non urgent request.
13:4.			Read request pending cycle number to inc urgent level if not granted.
3:0			Canvas arbiter weight

**Table 12-75 DMC\_AM7\_HOLD\_CTRL 0x007d**

Bit(s)	R/W	Default	Description
31:24			Write hold num. max outstanding request number.
23:16			Write hold release num. if the outstanding request == hold num, then hold this request unless the outstanding request number below the hold release number, then continue to request.
15:8			Read hold num. max outstanding request number.
7:0			Read hold release num. if the outstanding request == hold num, then hold this request unless the outstanding request number below the hold release number, then continue to request.

**Table 12-76 DMC\_AXI0\_CHAN\_CTRL 0x0080**

Bit(s)	R/W	Default	Description
31			Enable to incr 2 urgent levels if the pending cycles is doubled.
30			Enable to incr 3 urgent levels.
29:20			Write request pending cycle number to inc urgent level if not granted.
19			Axi0 default urgent control : 1 use AWUGT/ARUGT pins in the port. 0 : use bit [15:14] of this register.
18			Force this channel all request to be super urgent request.
17			Force this channel all request to be urgent request.
16			Force this channel all request to be non urgent request.
15:14			Axi0 default urgent level.
13:4			Read request pending cycle number to inc urgent level if not granted.
3:0			Arbiter weight

**Table 12-77 DMC\_AXI0\_HOLD\_CTRL 0x0081**

Bit(s)	R/W	Default	Description
31:24			Write hold num. max outstanding request number.
23:16			Write hold release num. if the outstanding request == hold num, then hold this request unless the outstanding request number below the hold release number, then continue to request.
15:8			Read hold num. max outstanding request number.
7:0			Read hold release num. if the outstanding request == hold num, then hold this request unless the outstanding request number below the hold release number, then continue to request.

**Table 12-78 DMC\_AXI0\_CHAN\_CTRL1 0x0082**

Bit(s)	R/W	Default	Description
19:16			FIQ status
15:12			IRQ status.
11			ARM FIQ controlled super urgent enable.
10			ARM FIQ controlled urgent enable.
9			ARM IRQ controlled super urgent enable.
8			ARM IRQ controlled urgent enable.
7			IRQ/FIQ control enable.
6:5			Not used.
4			Enable AXI0 auto urgent enable. When there's no other request, treat the AXI0 as super urgent request. Other wise, use the bit 3:0 to set the urgent.
3:2			A9 urgent if there's VIU request.
1:0			A9 urgent if there's request other than VIU

**Table 12-79 DMC\_AXI1\_CHAN\_CTRL 0x0084**

Bit(s)	R/W	Default	Description
31			Enable to incr 2 urgent levels if the pending cycles is doubled.
30			Enable to incr 3 urgent levels.
29:20			Write request pending cycle number to inc urgent level if not granted.
19.			Axi0 default urgent control: 1 use AWUGT/ARUGT pins in the port. 0: use bit [15:14] of this register.
18.			Force this channel all request to be super urgent request.
17.			Force this channel all request to be urgent request.
16.			Force this channel all request to be non-urgent request.
15:14			Axi1 default urgent level.
13:4.			Read request pending cycle number to inc urgent level if not granted.
3:0			Canvas arbiter weight



**Table 12-80 DMC\_AXI1\_HOLD\_CTRL 0x0085**

Bit(s)	R/W	Default	Description
31:24			Write hold num. max outstanding request number.
23:16			Write hold release num. if the outstanding request == hold num, then hold this request unless the outstanding request number below the hold release number, then continue to request.
15:8			Read hold num. max outstanding request number.
7:0			Read hold release num. if the outstanding request == hold num, then hold this request unless the outstanding request number below the hold release number, then continue to request.

**Table 12-81 DMC\_AXI1\_CHAN\_CTRL1 0x0086**

Bit(s)	R/W	Default	Description
31:28			FIQ status
27:24			IRQ status.
21:20			Mali QOS mode.
19:16			mail QOS high limit.
15:12			mail QOS mit limit.
11			ARM FIQ controlled super urgent enable.
10			ARM FIQ controlled urgent enable.
9			ARM IRQ controlled super urgent enable.
8			ARM IRQ controlled urgent enable.
7			IRQ/FIQ control enable.
6:0			not used.

**Table 12-82 DMC\_AXI2\_CHAN\_CTRL 0x0088**

Bit(s)	R/W	Default	Description
31			Enable to incr 2 urgent levels if the pending cycles is doubled.
30			Enable to incr 3 urgent levels.
29:20			Write request pending cycle number to inc urgent level if not granted.
19.			Axi0 default urgent control: 1 use AWUGT/ARUGT pins in the port. 0: use bit [15:14] of this register.
18.			Force this channel all request to be super urgent request.
17.			Force this channel all request to be urgent request.
16.			Force this channel all request to be non-urgent request.
15:14			Axi1 default urgent level.

Bit(s)	R/W	Default	Description
13:4			Read request pending cycle number to inc urgent level if not granted.
3:0			Canvas arbiter weight

Table 12-83 DMC\_AXI2\_HOLD\_CTRL 0x0089

Bit(s)	R/W	Default	Description
31:24			Write hold num. max outstanding request number.
23:16			Write hold release num. if the outstanding request == hold num, then hold this request unless the outstanding request number below the hold release number, then continue to request.
15:8			Read hold num. max outstanding request number.
7:0			Read hold release num. if the outstanding request == hold num, then hold this request unless the outstanding request number below the hold release number, then continue to request.

Table 12-84 DMC\_AXI3\_CHAN\_CTRL 0x008c

Bit(s)	R/W	Default	Description
31			Enable to incr 2 urgent levels if the pending cycles is doubled.
30			Enable to incr 3 urgent levels.
29:20			Write request pending cycle number to inc urgent level if not granted.
19			Axi0 default urgent control: 1 use AWUGT/ARUGT pins in the port. 0: use bit [15:14] of this register.
18			Force this channel all request to be super urgent request.
17			Force this channel all request to be urgent request.
16			Force this channel all request to be non-urgent request.
15:14			Axi1 default urgent level.
13:4			Read request pending cycle number to inc urgent level if not granted.
3:0			Canvas arbiter weight

Table 12-85 DMC\_AXI3\_HOLD\_CTRL 0x008d

Bit(s)	R/W	Default	Description
31:24			Write hold num. max outstanding request number.
23:16			Write hold release num. if the outstanding request == hold num, then hold this request unless the outstanding request number below the hold release number, then continue to request.
15:8			Read hold num. max outstanding request number.
7:0			Read hold release num. if the outstanding request == hold num, then hold this request unless the outstanding request number below the hold release number, then continue to request.

**Table 12-86 DMC\_AXI4\_CHAN\_CTRL 0x0090**

Bit(s)	R/W	Default	Description
31			Enable to incr 2 urgent levels if the pending cycles is doubled.
30			Enable to incr 3 urgent levels.
29:20			Write request pending cycle number to inc urgent level if not granted.
19			Axi0 default urgent control: 1 use AWUGT/ARUGT pins in the port. 0: use bit [15:14] of this register.
18			Force this channel all request to be super urgent request.
17			Force this channel all request to be urgent request.
16			Force this channel all request to be non-urgent request.
15:14			Axi1 default urgent level.
13:4			Read request pending cycle number to inc urgent level if not granted.
3:0			Canvas arbiter weight

**Table 12-87 DMC\_AXI4\_HOLD\_CTRL 0x0091**

Bit(s)	R/W	Default	Description
31:24			Write hold num. max outstanding request number.
23:16			Write hold release num. if the outstanding request == hold num, then hold this request unless the outstanding request number below the hold release number, then continue to request.
15:8			Read hold num. max outstanding request number.
7:0			Read hold release num. if the outstanding request == hold num, then hold this request unless the outstanding request number below the hold release number, then continue to request.

DMC\_AXI5\_CHAN\_CTRL 0x0094

Not used.

DMC\_AXI5\_HOLD\_CTRL 0x0095

**Table 12-88 DMC\_AXI6\_CHAN\_CTRL 0x0096**

Bit(s)	R/W	Default	Description
31			Enable to incr 2 urgent levels if the pending cycles is doubled.
30			Enable to incr 3 urgent levels.
29:20			Write request pending cycle number to inc urgent level if not granted.
19			Axi0 default urgent control: 1 use AWUGT/ARUGT pins in the port. 0: use bit [15:14] of this register.
18			Force this channel all request to be super urgent request.
17			Force this channel all request to be urgent request.
16			Force this channel all request to be non-urgent request.
15:14			Axi1 default urgent level.

Bit(s)	R/W	Default	Description
13:4			Read request pending cycle number to inc urgent level if not granted.
3:0			Canvas arbiter weight

Table 12-89 DMC\_AXI6\_HOLD\_CTRL 0x0097

Bit(s)	R/W	Default	Description
31:24			Write hold num. max outstanding request number.
23:16			Write hold release num. if the outstanding request == hold num, then hold this request unless the outstanding request number below the hold release number, then continue to request.
15:8			Read hold num. max outstanding request number.
7:0			Read hold release num. if the outstanding request == hold num, then hold this request unless the outstanding request number below the hold release number, then continue to request.

Table 12-90 DMC\_AXI7\_CHAN\_CTRL 0x009c

Bit(s)	R/W	Default	Description
31			Enable to incr 2 urgent levels if the pending cycles is doubled.
30			Enable to incr 3 urgent levels.
29:20			Write request pending cycle number to inc urgent level if not granted.
19			Axi0 default urgent control: 1 use AWUGT/ARUGT pins in the port. 0: use bit [15:14] of this register.
18			Force this channel all request to be super urgent request.
17			Force this channel all request to be urgent request.
16			Force this channel all request to be non-urgent request.
15:14			Axi1 default urgent level.
13:4			Read request pending cycle number to inc urgent level if not granted.
3:0			Canvas arbiter weight

Table 12-91 DMC\_AXI7\_HOLD\_CTRL 0x009d

Bit(s)	R/W	Default	Description
31:24			Write hold num. max outstanding request number.
23:16			Write hold release num. if the outstanding request == hold num, then hold this request unless the outstanding request number below the hold release number, then continue to request.
15:8			Read hold num. max outstanding request number.
7:0			Read hold release num. if the outstanding request == hold num, then hold this request unless the outstanding request number below the hold release number, then continue to request.

**Table 12-92 DMC\_AXI8\_CHAN\_CTRL 0x00a0**

Bit(s)	R/W	Default	Description
31			Enable to incr 2 urgent levels if the pending cycles is doubled.
30			Enable to incr 3 urgent levels.
29:20			Write request pending cycle number to inc urgent level if not granted.
19			Axi0 default urgent control: 1 use AWUGT/ARUGT pins in the port. 0: use bit [15:14] of this register.
18			Force this channel all request to be super urgent request.
17			Force this channel all request to be urgent request.
16			Force this channel all request to be non-urgent request.
15:14			Axi1 default urgent level.
13:4			Read request pending cycle number to inc urgent level if not granted.
3:0			Canvas arbiter weight

**Table 12-93 DMC\_AXI8\_HOLD\_CTRL 0x00a1**

Bit(s)	R/W	Default	Description
31:24			Write hold num. max outstanding request number.
23:16			Write hold release num. if the outstanding request == hold num, then hold this request unless the outstanding request number below the hold release number, then continue to request.
15:8			Read hold num. max outstanding request number.
7:0			Read hold release num. if the outstanding request == hold num, then hold this request unless the outstanding request number below the hold release number, then continue to request.

**Table 12-94 DMC\_AXI9\_CHAN\_CTRL 0x00a4**

Bit(s)	R/W	Default	Description
31			Enable to incr 2 urgent levels if the pending cycles is doubled.
30			Enable to incr 3 urgent levels.
29:20			Write request pending cycle number to inc urgent level if not granted.
19			Axi0 default urgent control: 1 use AWUGT/ARUGT pins in the port. 0: use bit [15:14] of this register.
18			Force this channel all request to be super urgent request.
17			Force this channel all request to be urgent request.
16			Force this channel all request to be non-urgent request.
15:14			Axi1 default urgent level.
13:4			Read request pending cycle number to inc urgent level if not granted.
3:0			Canvas arbiter weight

**Table 12-95 DMC\_AXI9\_HOLD\_CTRL 0x00a5**

Bit(s)	R/W	Default	Description
31:24			Write hold num. max outstanding request number.
23:16			Write hold release num. if the outstanding request == hold num, then hold this request unless the outstanding request number below the hold release number, then continue to request.
15:8			Read hold num. max outstanding request number.
7:0			Read hold release num. if the outstanding request == hold num, then hold this request unless the outstanding request number below the hold release number, then continue to request.

**Table 12-96 DMC\_AXI10\_CHAN\_CTRL 0x00a8**

Bit(s)	R/W	Default	Description
31			Enable to incr 2 urgent levels if the pending cycles is doubled.
30			Enable to incr 3 urgent levels.
29:20			Write request pending cycle number to inc urgent level if not granted.
19			Axi0 default urgent control: 1 use AWUGT/ARUGT pins in the port. 0: use bit [15:14] of this register.
18			Force this channel all request to be super urgent request.
17			Force this channel all request to be urgent request.
16			Force this channel all request to be non-urgent request.
15:14			Axi1 default urgent level.
13:4			Read request pending cycle number to inc urgent level if not granted.
3:0			Canvas arbiter weight

**Table 12-97 DMC\_AXI10\_HOLD\_CTRL 0x00a9**

Bit(s)	R/W	Default	Description
31:24			Write hold num. max outstanding request number.
23:16			Write hold release num. if the outstanding request == hold num, then hold this request unless the outstanding request number below the hold release number, then continue to request.
15:8			Read hold num. max outstanding request number.
7:0			Read hold release num. if the outstanding request == hold num, then hold this request unless the outstanding request number below the hold release number, then continue to request.

**Table 12-98 DMC\_AXI10\_CHAN\_CTRL1 0x00aa**

Bit(s)	R/W	Default	Description
11			Mali/NNA channel FIQ controlled super urgent enable.
10			Mali/NNA channel FIQ controlled urgent enable.

Bit(s)	R/W	Default	Description
9			Mali/NNA channel IRQ controlled super urgent enable.
8			Mali/NNA channel IRQ controlled urgent enable.
7			IRQ/FIQ controll enable.
6:0			Not used.

Table 12-99 DMC\_AXI11\_CHAN\_CTRL 0x00ac

Bit(s)	R/W	Default	Description
31			Enable to incr 2 urgent levels if the pending cycles is doubled.
30			Enable to incr 3 urgent levels.
29:20			Write request pending cycle number to inc urgent level if not granted.
19			Axi0 default urgent control: 1 use AWUGT/ARUGT pins in the port. 0: use bit [15:14] of this register.
18			Force this channel all request to be super urgent request.
17			Force this channel all request to be urgent request.
16			Force this channel all request to be non-urgent request.
15:14			Axi1 default urgent level.
13:4			Read request pending cycle number to inc urgent level if not granted.
3:0			Canvas arbiter weight

Table 12-100 DMC\_AXI11\_HOLD\_CTRL 0x00ad

Bit(s)	R/W	Default	Description
31:24			Write hold num. max outstanding request number.
23:16			Write hold release num. if the outstanding request == hold num, then hold this request unless the outstanding request number below the hold release number, then continue to request.
15:8			Read hold num. max outstanding request number.
7:0			Read hold release num. if the outstanding request == hold num, then hold this request unless the outstanding request number below the hold release number, then continue to request.

Table 12-101 DMC\_AXI12\_CHAN\_CTRL 0x00ae

Bit(s)	R/W	Default	Description
31			enable to incr 2 urgent levels if the pending cycles is doubled.
30			enable to incr 3 urgent levels.
29:20			write request pending cycle number to inc urgent level if not granted.
19			axi0 default urgent control : 1 use AWUGT/ARUGT pins in the port. 0 : use bit [15:14] of this register.

Bit(s)	R/W	Default	Description
18			force this channel all request to be super urgent request.
17			force this channel all request to be urgent request.
16			force this channel all request to be non urgent request.
15:14			axi1 default urgent level.
13:4			read request pending cycle number to inc urgent level if not granted.
3:0			canvas arbiter weight

**Table 12-102 DMC\_AXI12\_HOLD\_CTRL 0x00af**

Bit(s)	R/W	Default	Description
31:24			write hold num. max outstanding request number.
23:16			write hold release num. if the outstanding request == hold num, then hold this request unless the outstanding request number below the hold release number, then continue to request.
15:8			read hold num. max outstanding request number.
7:0			read hold release num. if the outstanding request == hold num, then hold this request unless the outstanding request number below the hold release number, then continue to request.

The following registers' base address is 0xff639000. Each register takes 4 byte address.

Each register's final address = 0xff639000 + offset \* 4.

**Table 12-103 DMC\_SEC\_RANGE\_CTRL 0x0000**

Bit(s)	R/W	Default	Description
31:16			16 range security level. each
15:0			16 range enable. each bit for one range to identify the range is enabled or not.

**Table 12-104 DMC\_SEC\_RANGE0\_CTRL 0x0001**

Bit(s)	R/W	Default	Description
31:16			range 0 end address higher 16 bits.
15:0			range 0 start address higher 16 bits.

DMC\_SEC\_RANGE1\_CTRL 0x0002

DMC\_SEC\_RANGE2\_CTRL 0x0003

DMC\_SEC\_RANGE3\_CTRL 0x0004

DMC\_SEC\_RANGE4\_CTRL 0x0005

DMC\_SEC\_RANGE5\_CTRL 0x0006

DMC\_SEC\_RANGE6\_CTRL 0x0007

DMC\_SEC\_RANGE7\_CTRL 0x0008



DMC\_SEC\_RANGE8\_CTRL 0x0009  
 DMC\_SEC\_RANGE9\_CTRL 0x000a  
 DMC\_SEC\_RANGE10\_CTRL 0x000b  
 DMC\_SEC\_RANGE11\_CTRL 0x000c  
 DMC\_SEC\_RANGE12\_CTRL 0x000d  
 DMC\_SEC\_RANGE13\_CTRL 0x000e  
 DMC\_SEC\_RANGE14\_CTRL 0x000f

**Table 12-105 DMC\_SEC\_RANGE0\_RID\_CTRL0 0x0010**

Bit(s)	R/W	Default	Description
31:0			range 0 end address higher 16 bits.

**Table 12-106 DMC\_SEC\_RANGE0\_RID\_CTRL1 0x0011**

Bit(s)	R/W	Default	Description
63:32			range 0 end address higher 16 bits.

**Table 12-107 DMC\_SEC\_RANGE0\_RID\_CTRL2 0x0012**

Bit(s)	R/W	Default	Description
95:64			range 0 end address higher 16 bits.

**Table 12-108 DMC\_SEC\_RANGE0\_RID\_CTRL3 0x0013**

Bit(s)	R/W	Default	Description
127:96			range 0 end address higher 16 bits.

DMC\_SEC\_RANGE1\_RID\_CTRL0 0x0014  
 DMC\_SEC\_RANGE1\_RID\_CTRL1 0x0015  
 DMC\_SEC\_RANGE1\_RID\_CTRL2 0x0016  
 DMC\_SEC\_RANGE1\_RID\_CTRL3 0x0017

DMC\_SEC\_RANGE2\_RID\_CTRL0 0x0018  
 DMC\_SEC\_RANGE2\_RID\_CTRL1 0x0019  
 DMC\_SEC\_RANGE2\_RID\_CTRL2 0x001a  
 DMC\_SEC\_RANGE2\_RID\_CTRL3 0x001b

DMC\_SEC\_RANGE3\_RID\_CTRL0 0x001c  
 DMC\_SEC\_RANGE3\_RID\_CTRL1 0x001d  
 DMC\_SEC\_RANGE3\_RID\_CTRL2 0x001e  
 DMC\_SEC\_RANGE3\_RID\_CTRL3 0x001f

DMC\_SEC\_RANGE4\_RID\_CTRL0 0x0020  
DMC\_SEC\_RANGE4\_RID\_CTRL1 0x0021  
DMC\_SEC\_RANGE4\_RID\_CTRL2 0x0022  
DMC\_SEC\_RANGE4\_RID\_CTRL3 0x0023

DMC\_SEC\_RANGE5\_RID\_CTRL0 0x0024  
DMC\_SEC\_RANGE5\_RID\_CTRL1 0x0025  
DMC\_SEC\_RANGE5\_RID\_CTRL2 0x0026  
DMC\_SEC\_RANGE5\_RID\_CTRL3 0x0027

DMC\_SEC\_RANGE6\_RID\_CTRL0 0x0028  
DMC\_SEC\_RANGE6\_RID\_CTRL1 0x0029  
DMC\_SEC\_RANGE6\_RID\_CTRL2 0x002a  
DMC\_SEC\_RANGE6\_RID\_CTRL3 0x002b

DMC\_SEC\_RANGE7\_RID\_CTRL0 0x002c  
DMC\_SEC\_RANGE7\_RID\_CTRL1 0x002d  
DMC\_SEC\_RANGE7\_RID\_CTRL2 0x002e  
DMC\_SEC\_RANGE7\_RID\_CTRL3 0x002f

DMC\_SEC\_RANGE8\_RID\_CTRL0 0x0030  
DMC\_SEC\_RANGE8\_RID\_CTRL1 0x0031  
DMC\_SEC\_RANGE8\_RID\_CTRL2 0x0032  
DMC\_SEC\_RANGE8\_RID\_CTRL3 0x0033

DMC\_SEC\_RANGE9\_RID\_CTRL0 0x0034  
DMC\_SEC\_RANGE9\_RID\_CTRL1 0x0035  
DMC\_SEC\_RANGE9\_RID\_CTRL2 0x0036  
DMC\_SEC\_RANGE9\_RID\_CTRL3 0x0037

DMC\_SEC\_RANGE10\_RID\_CTRL0 0x0038  
DMC\_SEC\_RANGE10\_RID\_CTRL1 0x0039  
DMC\_SEC\_RANGE10\_RID\_CTRL2 0x003a  
DMC\_SEC\_RANGE10\_RID\_CTRL3 0x003b

DMC\_SEC\_RANGE11\_RID\_CTRL0 0x003c  
DMC\_SEC\_RANGE11\_RID\_CTRL1 0x003d

DMC\_SEC\_RANGE11\_RID\_CTRL2 0x003e  
DMC\_SEC\_RANGE11\_RID\_CTRL3 0x003f

DMC\_SEC\_RANGE12\_RID\_CTRL0 0x0040  
DMC\_SEC\_RANGE12\_RID\_CTRL1 0x0041  
DMC\_SEC\_RANGE12\_RID\_CTRL2 0x0042  
DMC\_SEC\_RANGE12\_RID\_CTRL3 0x0043

DMC\_SEC\_RANGE13\_RID\_CTRL0 0x0044  
DMC\_SEC\_RANGE13\_RID\_CTRL1 0x0045  
DMC\_SEC\_RANGE13\_RID\_CTRL2 0x0046  
DMC\_SEC\_RANGE13\_RID\_CTRL3 0x0047

DMC\_SEC\_RANGE14\_RID\_CTRL0 0x0048  
DMC\_SEC\_RANGE14\_RID\_CTRL1 0x0049  
DMC\_SEC\_RANGE14\_RID\_CTRL2 0x004a  
DMC\_SEC\_RANGE14\_RID\_CTRL3 0x004b

DMC\_SEC\_RANGE15\_RID\_CTRL0 0x004c  
DMC\_SEC\_RANGE15\_RID\_CTRL1 0x004d  
DMC\_SEC\_RANGE15\_RID\_CTRL2 0x004e  
DMC\_SEC\_RANGE15\_RID\_CTRL3 0x004f

DMC\_SEC\_RANGE0\_WID\_CTRL0 0x0050  
DMC\_SEC\_RANGE0\_WID\_CTRL1 0x0051  
DMC\_SEC\_RANGE0\_WID\_CTRL2 0x0052  
DMC\_SEC\_RANGE0\_WID\_CTRL3 0x0053

DMC\_SEC\_RANGE1\_WID\_CTRL0 0x0054  
DMC\_SEC\_RANGE1\_WID\_CTRL1 0x0055  
DMC\_SEC\_RANGE1\_WID\_CTRL2 0x0056  
DMC\_SEC\_RANGE1\_WID\_CTRL3 0x0057

DMC\_SEC\_RANGE2\_WID\_CTRL0 0x0058  
DMC\_SEC\_RANGE2\_WID\_CTRL1 0x0059  
DMC\_SEC\_RANGE2\_WID\_CTRL2 0x005a  
DMC\_SEC\_RANGE2\_WID\_CTRL3 0x005b

DMC\_SEC\_RANGE3\_WID\_CTRL0 0x005c  
DMC\_SEC\_RANGE3\_WID\_CTRL1 0x005d  
DMC\_SEC\_RANGE3\_WID\_CTRL2 0x005e  
DMC\_SEC\_RANGE3\_WID\_CTRL3 0x005f

DMC\_SEC\_RANGE4\_WID\_CTRL0 0x0060  
DMC\_SEC\_RANGE4\_WID\_CTRL1 0x0061  
DMC\_SEC\_RANGE4\_WID\_CTRL2 0x0062  
DMC\_SEC\_RANGE4\_WID\_CTRL3 0x0063

DMC\_SEC\_RANGE5\_WID\_CTRL0 0x0064  
DMC\_SEC\_RANGE5\_WID\_CTRL1 0x0065  
DMC\_SEC\_RANGE5\_WID\_CTRL2 0x0066  
DMC\_SEC\_RANGE5\_WID\_CTRL3 0x0067

DMC\_SEC\_RANGE6\_WID\_CTRL0 0x0068  
DMC\_SEC\_RANGE6\_WID\_CTRL1 0x0069  
DMC\_SEC\_RANGE6\_WID\_CTRL2 0x006a  
DMC\_SEC\_RANGE6\_WID\_CTRL3 0x006b

DMC\_SEC\_RANGE7\_WID\_CTRL0 0x006c  
DMC\_SEC\_RANGE7\_WID\_CTRL1 0x006d  
DMC\_SEC\_RANGE7\_WID\_CTRL2 0x006e  
DMC\_SEC\_RANGE7\_WID\_CTRL3 0x006f

DMC\_SEC\_RANGE8\_WID\_CTRL0 0x0070  
DMC\_SEC\_RANGE8\_WID\_CTRL1 0x0071  
DMC\_SEC\_RANGE8\_WID\_CTRL2 0x0072  
DMC\_SEC\_RANGE8\_WID\_CTRL3 0x0073

DMC\_SEC\_RANGE9\_WID\_CTRL0 0x0074  
DMC\_SEC\_RANGE9\_WID\_CTRL1 0x0075  
DMC\_SEC\_RANGE9\_WID\_CTRL2 0x0076  
DMC\_SEC\_RANGE9\_WID\_CTRL3 0x0077

DMC\_SEC\_RANGE10\_WID\_CTRL0 0x0078  
DMC\_SEC\_RANGE10\_WID\_CTRL1 0x0079  
DMC\_SEC\_RANGE10\_WID\_CTRL2 0x007a

DMC\_SEC\_RANGE10\_WID\_CTRL3 0x007b

DMC\_SEC\_RANGE11\_WID\_CTRL0 0x007c

DMC\_SEC\_RANGE11\_WID\_CTRL1 0x007d

DMC\_SEC\_RANGE11\_WID\_CTRL2 0x007e

DMC\_SEC\_RANGE11\_WID\_CTRL3 0x007f

DMC\_SEC\_RANGE12\_WID\_CTRL0 0x0080

DMC\_SEC\_RANGE12\_WID\_CTRL1 0x0081

DMC\_SEC\_RANGE12\_WID\_CTRL2 0x0082

DMC\_SEC\_RANGE12\_WID\_CTRL3 0x0083

DMC\_SEC\_RANGE13\_WID\_CTRL0 0x0084

DMC\_SEC\_RANGE13\_WID\_CTRL1 0x0085

DMC\_SEC\_RANGE13\_WID\_CTRL2 0x0086

DMC\_SEC\_RANGE13\_WID\_CTRL3 0x0087

DMC\_SEC\_RANGE14\_WID\_CTRL0 0x0088

DMC\_SEC\_RANGE14\_WID\_CTRL1 0x0089

DMC\_SEC\_RANGE14\_WID\_CTRL2 0x008a

DMC\_SEC\_RANGE14\_WID\_CTRL3 0x008b

DMC\_SEC\_RANGE15\_WID\_CTRL0 0x008c

DMC\_SEC\_RANGE15\_WID\_CTRL1 0x008d

DMC\_SEC\_RANGE15\_WID\_CTRL2 0x008e

DMC\_SEC\_RANGE15\_WID\_CTRL3 0x008f

**Table 12-109 DMC\_DES\_CTRL 0x0095**

Bit(s)	R/W	Default	Description
1			DES enable. 1: DES enable. 0: DES disable. default is 1.
0			DES register mask. if write 1 only. after write 1, DES_CTRL, DES_KEY, DES_padding, and CFG_CA_REMAP register can't be write and read.

**Table 12-110 DMC\_SHA\_CTRL 0x0096**

Bit(s)	R/W	Default	Description
31:24		0xa500-a500	SHA check control 0xa5 : disable SHA check. others enable SHA check.
23:16			SHA check first round to generate expect data control. 0xa5: enable this feature. the others will disable it
15:8			SHA check disable too long time check enable. 0xa5: disable this feature : others enable this feature.

**Table 12-111 DMC\_SHA\_PERIOD 0x0097**

Bit(s)	R/W	Default	Description
15:8		0x0000-0303	timer to check SHA disable time in 1mS.
7:0			how long to trigger SHA check once in 1mS.

**Table 12-112 DMC\_ALERT\_CTRL 0x0099**

Bit(s)	R/W	Default	Description
31:24		0xa5a5-a500	o enable alert generation if SHA check error. value 0xa5 to disable generate SHA check alert violation. others enable this function.
23:16			to enable alert generation 2 Cycle APW write data check violation alert generation. value 0xa5 to disable this violation. others enable this function.
15:8			to generate alert when sha disable timer violation.

**Table 12-113 DMC\_CA\_REMAP\_L 0x009b**

Bit(s)	R/W	Default	Description
63:60			New address for index 15
59:56			New address for index 14
55:52			New address for index 13
51:48			New address for index 12
47:44			New address for index 11
43:40			New address for index 10
39:36			New address for index 9
35:32			New address for index 8
31:28			New address for index 7
27:24			New address for index 6
23:20			New address for index 5
19:16			New address for index 4
15:12			New address for index 3
11:8			New address for index 2
7:4			New address for index 1
3:0			New address for index 0

**Table 12-114 DMC\_CA\_REMAP\_H 0x009c**

Bit(s)	R/W	Default	Description
63:60			New address for index 15
59:56			New address for index 14

Bit(s)	R/W	Default	Description
55:52			New address for index 13
51:48			New address for index 12
47:44			New address for index 11
43:40			New address for index 10
39:36			New address for index 9
35:32			New address for index 8
31:28			New address for index 7
27:24			New address for index 6
23:20			New address for index 5
19:16			New address for index 4
15:12			New address for index 3
11:8			New address for index 2
7:4			New address for index 1
3:0			New address for index 0

Table 12-115 DMC\_PROT0\_RANGE 0x00a0

Bit(s)	R/W	Default	Description
31:16			Range end address.
15:0			Range end address.

Table 12-116 DMC\_PROT0\_CTRL 0x00a1

Bit(s)	R/W	Default	Description
25			Protection 0 write access block function. If enabled, the access wouldn't write to the ddr sdram. If not enabled only generate a interrupt, but the access still wrote to ddr.
24			Protection range 0 enable.
23:16			Each bit to enable one of the 8 ambus channel for the protection function.
15:0			Each bit to enable one of the 15 channel input for the protection function.

Table 12-117 DMC\_PROT1\_RANGE 0x00a2

Bit(s)	R/W	Default	Description
31:16			Range end address.
15:0			Range end address.

**Table 12-118 DMC\_PROT1\_CTRL 0x00a3**

Bit(s)	R/W	Default	Description
25			Protection 1 write access block function. If enabled, the access wouldn't write to the ddr sdram. If not enabled only generate a interrupt, but the access still wrote to ddr.
24			Protection range 1 enable bit.
23:16			Each bit to enable one of the 8 ambus channel for the protection function.
15:0			Each bit to enable one of the 15 channel input for the protection function.

DMC\_WTCH0\_D0 0x00a4

DMC\_WTCH0\_D1 0x00a5

DMC\_WTCH0\_D2 0x00a6

DMC\_WTCH0\_D3 0x00a7

**Table 12-119 DMC\_WTCH0\_RANGE 0x00a8**

Bit(s)	R/W	Default	Description
31:16			Start address high 16
15:0			Start address high 16

**Table 12-120 DMC\_WTCH0\_CTRL 0x00a9**

Bit(s)	R/W	Default	Description
23:0			8 ambus and 16 axibus input channels select.

**Table 12-121 DMC\_WTCH0\_CTRL1 0x00aa**

Bit(s)	R/W	Default	Description
31:16			Start address high 16.
2			Watch point 0 enable.
1:0			Watch point 0 type. 2'b00: double bytes. Only watch point data 15:0 and data strb 1:0 is valid. 2'b01: 4 bytes. 2'b10: 8 bytes. 2'b11, all 16 bytes.

DMC\_WTCH1\_D0 0x00ab

DMC\_WTCH1\_D1 0x00ac

DMC\_WTCH1\_D2 0x00ad

DMC\_WTCH1\_D3 0x00ae

**Table 12-122 DMC\_WTCH1\_RANGE 0x00af**

Bit(s)	R/W	Default	Description
15:0			Start address high 16



**Table 12-123 DMC\_WTCH1\_CTRL 0x00b0**

Bit(s)	R/W	Default	Description
23:0			8 ambus and 16 axibus input channels select.

**Table 12-124 DMC\_WTCH1\_CTRL1 0x00b1**

Bit(s)	R/W	Default	Description
31:16			Start address high 16.
2			Watch point 0 enable.
1:0			Watch point0 type. 2'b00: double bytes. Only watch point data 15:0 and data strb 1:0 is valid. 2'b01: 4 bytes. 2'b10: 8 bytes. 2'b11, all 16 bytes.

**Table 12-125 DMC\_TRAP0\_RANGE 0x00b2**

Bit(s)	R/W	Default	Description
31:16			Trap0 end address
2			Start0 address.

**Table 12-126 DMC\_TRAP0\_CTRL 0x00b3**

Bit(s)	R/W	Default	Description
31			Trap0 port ID 3 enable.
30			Trap0 port ID 2 enable.
29			Trap0 port ID 1 enable.
28			Trap0 port ID 0 enable.
27			Trap0 port ID 3 subid enable.
26			Trap0 port ID 2 subid enable.
25			Trap0 port ID 1 subid enable.
24			Trap0 port ID 0 subid enable.
16:20			Trap0 port ID 1 ID number.
14:11			Trap0 port ID 1 subid ID number.
8:4			Trap0 port ID 0 ID number.
3:0			Trap0 port ID 0 subid ID number.

**Table 12-127 DMC\_TRAP0\_CTRL2 0x00b4**

Bit(s)	R/W	Default	Description
31:17			Not used.
16:20			Trap0 port ID 3 ID number.
14:11			Trap0 port ID 3 subid ID number.

Bit(s)	R/W	Default	Description
8:4.			Trap0 port ID 2 ID number.
3:0			Trap0 port ID 2 subid ID number.

Table 12-128 DMC\_TRAP1\_RANGE 0x00b5

Bit(s)	R/W	Default	Description
31:16			Trap end address
15:0			Start address

Table 12-129 DMC\_TRAP1\_CTRL 0x00b6

Bit(s)	R/W	Default	Description
31			Trap0 port ID 3 enable.
30			Trap0 port ID 2 enable.
29			Trap0 port ID 1 enable.
28			Trap0 port ID 0 enable.
27			Trap0 port ID 3 subid enable.
26			Trap0 port ID 2 subid enable.
25			Trap0 port ID 1 subid enable.
24			Trap0 port ID 0 subid enable.
16:20			Trap0 port ID 1 ID number.
14:11			Trap0 port ID 1 subid ID number.
8:4			Trap0 port ID 0 ID number.
3:0			Trap0 port ID 0 subid ID number.

Table 12-130 DMC\_TRAP1\_CTRL2 0x00b7

Bit(s)	R/W	Default	Description
31:17			Not used.
16:20			Trap1 port ID 1 ID number.
14:11			Trap1 port ID 1 subid ID number.
8:4.			Trap1 port ID 0 ID number.
3:0.			Trap1 port ID 0 subid ID number.

**Table 12-131 DMC\_SEC\_STATUS 0x00b8**

Bit(s)	R/W	Default	Description
31:2			Not used.
6			SHA check violation. 1 sha check violation happens. write 1 to clean this bit.
5			1: SHA check disabled time too long violation. write 1 to clean this bit.
4			1: Sha exp data register write violation(APB bus WDATA not equare the register value when APB write). write 1 to clean this bit.
3			1 : normal security register write violation.( APB bus WDATA not equare the register value when APB write). write 1 to clean this bit to 0.
2			sec_alert. 1 DMC security register alert function triggered. can't clean. only re-set DMC can clear this bit.
1			Write security violation
0			Read security violation.

DMC\_VIO\_ADDR0 0x00b9

**Table 12-132 DMC\_VIO\_ADDR1 0x00ba**

Bit(s)	R/W	Default	Description
31:25			Not used. Always 0.
24			ddr0 secure check violation
23			ddr0 protection 1 violation.
22			ddr0 protection 0 violation.
21			ddr0 watch 1 catch.
20			ddr0 watch 0 catch.
19.			ddr0 write address overflow. write out of DDR size.
18:16			ddr0 write violation AWPROT bits.
15:0			ddr0_write violation ID.

DMC\_VIO\_ADDR2 0x00bb

**Table 12-133 DMC\_VIO\_ADDR3 0x00bc**

Bit(s)	R/W	Default	Description
24			ddr0 read secure check violation.
23			ddr0 read protection 1 violation.
22			ddr0 read protection 0 violation.
21			ddr0 read trap1 violation.
20			ddr0 read trap0 violation.
19			ddr 0 read address overflow. write out of DDR size.
18:16			ddr 0 read violation ARPROT bits.
15:0			ddr 0 read violation ID.

Table 12-134 DDR0\_ADDRMAP\_0 0x00d0

Bit(s)	R/W	Default	Description
29:25			ca8
24:20			ca7
19:15			ca6
14:10			ca5
9:5			ca4
4:0			ca3

Table 12-135 DDR0\_ADDRMAP\_1 0x00d1

Bit(s)	R/W	Default	Description
29:25			ra2
24:20			ra1
19:15			ra0
14:10			ca11
9:5			ca10
4:0			ca9

Table 12-136 DDR0\_ADDRMAP\_2 0x00d2

Bit(s)	R/W	Default	Description
29:25			ra8
24:20			ra7
19:15			ra6
14:10			ra5
9:5			ra4
4:0			ra3

Table 12-137 DDR0\_ADDRMAP\_3 0x00d3

Bit(s)	R/W	Default	Description
29:25			ra14
24:20			ra13
19:15			ra12
14:10			ra11
9:5			ra10
4:0			ra9

Table 12-138 DDR0\_ADDRMAP\_4 0x00d4

Bit(s)	R/W	Default	Description
29:25			ra16 for DDR4 SDRAM
24:20			bg1 for DDR4 SDRAM.
19:15			ba2. or bg0 for DDR4.
14:10			ba1.
9:5			ba0.
4:0			ra15.

Table 12-139 DDR1\_ADDRMAP\_0 0x00d5

Bit(s)	R/W	Default	Description
29:25			ca8
24:20			ca7
19:15			ca6
14:10			ca5
9:5			ca4
4:0			ca3

Table 12-140 DDR1\_ADDRMAP\_1 0x00d6

Bit(s)	R/W	Default	Description
29:25			ra2
24:20			ra1
19:15			ra0
14:10			ca11
9:5			ca10
4:0			ca9

Table 12-141 DDR1\_ADDRMAP\_2 0x00d7

Bit(s)	R/W	Default	Description
29:25			ra8
24:20			ra7
19:15			ra6
14:10			ra5
9:5			ra4
4:0			ra3

Table 12-142 DDR1\_ADDRMAP\_3 0x00d8

Bit(s)	R/W	Default	Description
29:25			ra14
24:20			ra13
19:15			ra12
14:10			ra11
9:5			ra10
4:0			ra9

Table 12-143 DDR1\_ADDRMAP\_4 0x00d9

Bit(s)	R/W	Default	Description
29:25			ra16 for DDR4 SDRAM
24:20			bg1 for DDR4 SDRAM.
19:15			ba2. or bg0 for DDR4 SDRAM.
14:10			ba1.
9:5			ba0.
4:0			ra15.

Table 12-144 DMC\_DDR\_CTRL 0x00da

Bit(s)	R/W	Default	Description
31:28			16bit selection for DDR3/4 not balanced mode. 4'b1000: 3G byte mode. low 2G byte is in 32 bits mode. 2G~3G is 16 bits mode. 4'b0100: 1.5G byte mode. low 1G byte is in 32 bits mode. 1G~1.5G is in 16 bits mode. 4'b0010: 768M byte mode. low 512M byte is in 32 bits mode. 512M~768M is in 16 bits mode. 4'b0001: 384M byte mode. low 25M byte is in 32 bits mode. 256M~384M is in 16 bits mode. 4'b0000 or others balance mode. ether 32 bits mode or 16 bits mode depends on bit
27			0 : canvas use 64 bytes boundary 1 : canvas use 32 bytes boundary.
24:22			3'b000 : ddr3 mode. 3'b001 : ddr4 mode. 3'b010 : lpddr3 mode. 3'b011 : lpddr4 mode
21			rank1 enable bit. if 1, rank1 used the address map is as bit 5:3 defined.
20			DDR4 BG1 enable bit.
18			always 0.
16			1 only use 16 bits data in a 32 bits phy data interface. 0 : normal data interface.
9			ddr1_size[3], combine with bit 5:3. for ddr1_size[3:0]
8			ddr0_size[3], combine with bit 2:0 for ddr0_size[3:0]

Bit(s)	R/W	Default	Description
5:3			DDR rank 1 size. 4'b0000 : DDR rank 1 is 128M byte.  4'b0001 : DDR rank 1 is 256M byte.  4'b0010 : DDR rank 1 is 512M byte.  4'b0011 : DDR rank 1 is 1G byte.  4'b0100 : DDR rank 1 is 2G byte. 4'b0101 : DDR rank 1 is 4G byte. others : reserved.
2:0			DDR rank 0 size. 4'b0000 : DDR rank 0 is 128M byte.  4'b0001 : DDR rank 0 is 256M byte.  4'b0010 : DDR rank 0 is 512M byte.  4'b0011 : DDR rank 0 is 1G byte.  4'b0100 : DDR rank 0 is 2G byte.  4'b0101 : DDR rank 0 is 4G byte.  4'b1000 : DDR rank 0 is 4G byte.  4'b1001 : DDR rank 0 is 4G byte.  others : reserved.

Table 12-145 DDR\_APB\_SEC\_CTRL 0x00db

Bit(s)	R/W	Default	Description
19:16			DMC normal APB register secure control.
19:			1: all can write those register. 0: the APB_PROT[0] must match the bit 0 to write those register.
15:12			DMC sticky APB register secure control.
15.			1: All APB bus can write those registers. 0: The APB_PROT[0] must match the bit 12 to write those register.
11:8.			DMC DDR PLL clock related APB register secure control.
11.			1: All APB bus can write those registers. 0: The APB_PROT[0] must match the bit 8 to write those register.
7:4.			DMC DDR SDRAM protocol control register control
11.			1: All APB bus can write those registers. 0: The APB_PROT[0] must match the bit 4 to write those register.
3:0.			LPDDR4 PHY APB register secure control.
3			1: All APB bus can write those registers. 0: The APB_PROT[0] must match the bit 0 to write those register.

**Table 12-146 DDR\_MEM\_PD\_CTRL 0x00bd**

Bit(s)	R/W	Default	Description
31:14			Not used.
13:12			wc_fifo
11:10			wd_mem
9:8			rd_mem
7:6			dfifo
5:4			cfifo
3:2			cav_ram
1:0			sticky ram

DMC\_TEST\_WRCMD\_ADDR 0x00dc

DMC\_TEST\_RDRSP\_ADDR 0x00dd

DMC\_TEST\_RDCMD\_ADDR 0x00de

**Table 12-147 DMC\_TEST\_WDG 0x00df**

Bit(s)	R/W	Default	Description
31:16			Write response watch dog.
15:0			Read response watch dog.

DMC\_TEST\_STA 0x00e0

DMC\_TEST\_EDA 0x00e1

**Table 12-148 DMC\_TEST\_CTRL 0x00e2**

Bit(s)	R/W	Default	Description
31			enable test.
30			when enable test, enable the write to DDR function.
29			when enable test, enable the read from DDR function.
28			when enable test, enable the sha calculation function must be same as read enable but without write function.
27			enable to compare data. when do the read enable to enable the error comparing. suppose the read data should be same as the data in the write buffer.
26			0: save sha result to test_sha_message registers. 1 : don't save.
25			address generation type.
24			0 : use the DMC_TEST_NUM register as the counter of test numbers.
23			1 : the first write is {WD3, WD2,WD1,WD0}, then the latter is the previous data plus a pattern. ({ + WD7, + WD6, + WD5, + WD4}).
23			1 compare the sha result with the test sha message registers. 0 : dont compare the result.
22:20			read repeat times. for non-sha function, we can define multi times of the read. the test module would repeat the same address repeat times.



Bit(s)	R/W	Default	Description
19			limit write.
18			limit read.
17:16			sha mode for sha function enabled.
15:8.			write outstanding commands limit.
7:0			read outstanding commands limit.

DMC\_TEST\_NUM 0x00e3

DMC\_TEST\_WD0 0x00e4

DMC\_TEST\_WD1 0x00e5

DMC\_TEST\_WD2 0x00e6

DMC\_TEST\_WD3 0x00e7

DMC\_TEST\_WD4 0x00e8

DMC\_TEST\_WD5 0x00e9

DMC\_TEST\_WD6 0x00ea

DMC\_TEST\_WD7 0x00eb

DMC\_TEST\_RD0 0x00ec

DMC\_TEST\_RD1 0x00ed

DMC\_TEST\_RD2 0x00ee

DMC\_TEST\_RD3 0x00ef

DMC\_TEST\_RD4 0x00f0

DMC\_TEST\_RD5 0x00f1

DMC\_TEST\_RD6 0x00f2

DMC\_TEST\_RD7 0x00f3

DMC\_TEST\_ERR\_ADDR 0x00f4

DMC\_TEST\_ERR\_CNT 0x00f5

Table 12-149 DMC\_TEST\_STS 0x00f6

Bit(s)	R/W	Default	Description
31			test done bit. write 1 to clean.
30			indicate address err
29:7			not used.
6			read data resp error(caused by security or rd latency).
5			test MRR/MPR rd latency error. write 1 clear
4			sha done. write 1 to clean.
3			write done. write 1 to clean.
2			read done. write 1 to clean

Bit(s)	R/W	Default	Description
1			write watchdog triggered. write 1 to clean
0			read watchdog triggered. write 1 to clean

DMC\_TEST\_SHA\_MSG0 0x00f8

DMC\_TEST\_SHA\_MSG1 0x00f9

DMC\_TEST\_SHA\_MSG2 0x00fa

DMC\_TEST\_SHA\_MSG3 0x00fb

DMC\_TEST\_SHA\_MSG4 0x00fc

DMC\_TEST\_SHA\_MSG5 0x00fd

DMC\_TEST\_SHA\_MSG6 0x00fe

DMC\_TEST\_SHA\_MSG7 0x00ff

For below register, the base address is 0xff639400, each register's final address = base address + offset\*4.

DMC\_TEST\_WD8 0x0018

DMC\_TEST\_WD9 0x0019

DMC\_TEST\_WD10 0x001a

DMC\_TEST\_WD11 0x001b

DMC\_TEST\_WD12 0x001c

DMC\_TEST\_WD13 0x001d

DMC\_TEST\_WD14 0x001e

DMC\_TEST\_WD15 0x001f

DMC\_TEST\_RD0 0x0020

DMC\_TEST\_RD8 0x0028

DMC\_TEST\_RD9 0x0029

DMC\_TEST\_RD10 0x002a

DMC\_TEST\_RD11 0x002b

DMC\_TEST\_RD12 0x002c

DMC\_TEST\_RD13 0x002d

DMC\_TEST\_RD14 0x002e

DMC\_TEST\_RD15 0x002f

DMC\_TEST\_COMP\_MASK 0x0033

**Table 12-150 DMC\_TEST\_RDBI0 0x0034**

Bit(s)	R/W	Default	Description
31:16			the second cycle.
15:0			the first cycle.

**Table 12-151 DMC\_TEST\_RDBI1 0x0035**

Bit(s)	R/W	Default	Description
31:16			Forth cycle.
15:0			third cycle.

**Table 12-152 DMC\_TEST\_WSTRB0 0x0036**

Bit(s)	R/W	Default	Description
31:16			the second cycle.
15:0			the first cycle.

**Table 12-153 DMC\_TEST\_WSTRB1 0x0037**

Bit(s)	R/W	Default	Description
31:16			Forth cycle.
15:0			third cycle.

**Table 12-154 DMC\_TEST\_DRAM\_CMD 0x0038**

Bit(s)	R/W	Default	Description
31			cmd done. write 0 to clean.
30			data done. write 0 to clean.
4:0			only one bit can be 1. read data stored in DMC_TEST_RD* write data from DMC_TEST_W
4			LPDDR4 MPC write data command( MPC WR FIFO).
3			LPDDR4 MPC read data command (MPC RD Calibration and RD FIFO).
2			LPDDR4 MPC-1 command ( NOP, Start DQS interval ....)
1			mrr command.
0			mrw command.

**Table 12-155 DMC\_TEST\_DRAM\_CMD\_CODE 0x0039**

Bit(s)	R/W	Default	Description
27:26			128 bits data cycles . 0: 1 clock cycles; 1: 2 clock cycles; 2: 3 clock cycles; 3:4 clock cycles.
25			MRW/MRR/MPC command rank 1 select. 1: select. 0: not select.
24.			MRW/MRR/MPC command rank 0 select. 1: select. 0: not select.
23:16			MR addr. DDR4 case : 18:16 ba [2:0]. 20:19 BG [1:0].
15:0			opcode.

**Table 12-156 DMC\_TEST\_DRAM\_CMD\_TIME 0x003a**

Bit(s)	R/W	Default	Description
31:16			PRE CMD timer.
15:0			POST CMD timer

DMC\_SEC\_SHA\_MSG0 0x0040

DMC\_SEC\_SHA\_MSG1 0x0041

DMC\_SEC\_SHA\_MSG2 0x0042

DMC\_SEC\_SHA\_MSG3 0x0043

DMC\_SEC\_SHA\_MSG4 0x0044

DMC\_SEC\_SHA\_MSG5 0x0045

DMC\_SEC\_SHA\_MSG6 0x0046

DMC\_SEC\_SHA\_MSG7 0x0047

For below registers, the base address is 0xff638400, each register's final address = base address = offset \* 4.

**Table 12-157 DMC\_DRAM\_TMRD 0x0000**

Bit(s)	R/W	Default	Description
3:0			tMRD.

**Table 12-158 DMC\_DRAM\_TRFC 0x0001**

Bit(s)	R/W	Default	Description
9:0			tRFC

**Table 12-159 DMC\_DRAM\_TRP 0x0002**

Bit(s)	R/W	Default	Description
21:16			tRP for precharge all banks.
5:0			tRP for precharge one bank.

**Table 12-160 DMC\_DRAM\_TRTW 0x0003**

Bit(s)	R/W	Default	Description
5:0			tRTW

**Table 12-161 DMC\_DRAM\_TCL 0x0004**

Bit(s)	R/W	Default	Description
5:0			CL/tRL. read latency.

**Table 12-162 DMC\_DRAM\_TCWL 0x0005**

Bit(s)	R/W	Default	Description
5:0			CWL: write latency.

**Table 12-163 DMC\_DRAM\_TRAS 0x0006**

Bit(s)	R/W	Default	Description
7:0			tRAS. minimum active to precharge time for same bank.

**Table 12-164 DMC\_DRAM\_TRC 0x0007**

Bit(s)	R/W	Default	Description
7:0			tRC. minimum active to active time for same bank.

**Table 12-165 DMC\_DRAM\_TRCD 0x0008**

Bit(s)	R/W	Default	Description
7:0			tRCD active to read/write timing for same bank.

**Table 12-166 DMC\_DRAM\_TRRD 0x0009**

Bit(s)	R/W	Default	Description
21:16			tRRD_I active bank A to active B in same band group for DDR4.
5:0			tRRD/tRRD_s active bank A to active bank b time.

**Table 12-167 DMC\_DRAM\_TFAW 0x000a**

Bit(s)	R/W	Default	Description
8:0			tFAW. four active command windows

**Table 12-168 DMC\_DRAM\_TRTP 0x000b**

Bit(s)	R/W	Default	Description
5:0			tRTP.

**Table 12-169 DMC\_DRAM\_TWR 0x000c**

Bit(s)	R/W	Default	Description
5:0			tWR.

**Table 12-170 DMC\_DRAM\_TWTR 0x000d**

Bit(s)	R/W	Default	Description
5:0			tWTR.

**Table 12-171 DMC\_DRAM\_TCCD 0x000e**

Bit(s)	R/W	Default	Description
19:16			tCCD/tCCD_I.
3:0			tCCD/tCCD_s read to read command time or write to write command time.

**Table 12-172 DMC\_DRAM\_TEXSR 0x000f**

Bit(s)	R/W	Default	Description
9:0			tEXSR. EXIT SELF-REFRESH to read/write command.

**Table 12-173 DMC\_DRAM\_TXS 0x0010**

Bit(s)	R/W	Default	Description
9:0			tEXSR. EXIT SELF-REFRESH to read/write command.

**Table 12-174 DMC\_DRAM\_TXP 0x0011**

Bit(s)	R/W	Default	Description
3:0			tXP. EXIT power down to other command time

**Table 12-175 DMC\_DRAM\_TXPDLL 0x0012**

Bit(s)	R/W	Default	Description
9:0			tXPDLL, EXIT power down to read/write command time(need to rellock PLL).

**Table 12-176 DMC\_DRAM\_TZQCS 0x0013**

Bit(s)	R/W	Default	Description
7:0			ZQCS command to other command time.

**Table 12-177 DMC\_DRAM\_TCKSRE 0x0014**

Bit(s)	R/W	Default	Description
4:0			enter self-refresh to disable clock time.

**Table 12-178 DMC\_DRAM\_TCKSRX 0x0015**

Bit(s)	R/W	Default	Description
4:0			enable clock to exit self-refresh time.

**Table 12-179 DMC\_DRAM\_TCKE 0x0016**

Bit(s)	R/W	Default	Description
4:0			CKE high or low minimum time.

**Table 12-180 DMC\_DRAM\_TMOD 0x0017**

Bit(s)	R/W	Default	Description
4:0			tMOD. MRR/MRW to other command time.

**Table 12-181 DMC\_DRAM\_TDQS 0x0018**

Bit(s)	R/W	Default	Description
3:0			tDQS. the delay to access different rank.

DMC\_DRAM\_TRSTL 0x0019

Not used.

**Table 12-182 DMC\_DRAM\_TZQLAT 0x001a**

Bit(s)	R/W	Default	Description
5:0			ZQ LATCH command to other command timing in LPDDR4 mode.

**Table 12-183 DMC\_DRAM\_TMRR 0x001b**

Bit(s)	R/W	Default	Description
7:0			tMRR not used in DMC. not support MR READ.

**Table 12-184 DMC\_DRAM\_TCKESR 0x001c**

Bit(s)	R/W	Default	Description
9:0			tCKESR. CKE low minimum pulse in self refresh mode.

DMC\_DRAM\_TDPD 0x001d

Not support.

**Table 12-185 DMC\_DRAM\_DFITCTRLDELAY 0x001e**

Bit(s)	R/W	Default	Description
3:0			DFI_t_ctrl dealy

**Table 12-186 DMC\_DRAM\_DFITPHYWRDATA 0x001f**

Bit(s)	R/W	Default	Description
5:0			dfi_t_phy_wrdata.

**Table 12-187 DMC\_DRAM\_DFITPHYWRLAT 0x0020**

Bit(s)	R/W	Default	Description
5:0			dfi_t_phy_wrlat. in DDR3/4/LPDDR3 mode: WL -5. in LPDDR4 mode: WL -5 + 2.

**Table 12-188 DMC\_DRAM\_DFITRDDATAEN 0x0021**

Bit(s)	R/W	Default	Description
5:0			dfi_t_rddata_en. in DDR3/4/LPDDR3 mode: RL -5. in LPDDR4 mode : RL -5 + 1.

**Table 12-189 DMC\_DRAM\_DFITPHYRDLAT 0x0022**

Bit(s)	R/W	Default	Description
5:0			dfi_t_rdlat.

**Table 12-190 DMC\_DRAM\_DFITCTRLUPDMIN 0x0023**

Bit(s)	R/W	Default	Description
7:0			CTRLUPD_MIN minimum clock cycle to maintain CTRLUPD_REQ.

**Table 12-191 DMC\_DRAM\_DFITCTRLUPDMAX 0x0024**

Bit(s)	R/W	Default	Description
7:0			CTRLUPD_MAX. maximum clock cycle to maintain CTRLUPD_REQ if no CTRLUPD_ACK response.

DMC\_DRAM\_DFITMSTRRESP 0x0025

Not used.

DMC\_DRAM\_DFITREFMSKI 0x0026

Not used.

DMC\_DRAM\_DFITCTRLUPDI 0x0027

Not used.

**Table 12-192 DMC\_DRAM\_DFITDRAMCLK 0x0028**

Bit(s)	R/W	Default	Description
17			dram clk1 enable.
16			dram clk0 enable.



Bit(s)	R/W	Default	Description
15:8			DRAM CLK disable waiting time
7:0			DRAM CLK enable timer

**Table 12-193 DMC\_DRAM\_DFITLPRESP 0x002a**

Bit(s)	R/W	Default	Description
3:0			dfi_lp_ctrl_req response time. after dfi_lp_ctrl_req asserted, and after response time if there's still no dfi_lp_ack response, then drop the dfi_lp_ctrl_req.

**Table 12-194 DMC\_DRAM\_DFITPHYMSTR 0x002b**

Bit(s)	R/W	Default	Description
15			1: enable DFIPHYMASTER INTERFACE 0 disable DFIPHYMSTR en response.

**Table 12-195 DMC\_DRAM\_TCCKECK 0x002c**

Bit(s)	R/W	Default	Description
4:0			tCCKECK from CKE low to assert dfi_dram_clk_disable time. this time + dfi_t_ctrl_delay

**Table 12-196 DMC\_DRAM\_TREFI 0x002d**

Bit(s)	R/W	Default	Description
31:24			tZQCI dmc send zqci period. unit is how much auto refresh period.
23:16			pvti dmc send dfi_ctrlupd_req period. unit is one auto refresh period.
15:8			tREFI.dmc send auto refresh command period. unit is 100ns.
7:0			t100ns period. unit is dmc clock cycles

**Table 12-197 DMC\_DRAM\_TSR 0x002e**

Bit(s)	R/W	Default	Description
5:0			tSR. self refresh enter to exit time.

**Table 12-198 DMC\_DRAM\_TCCDMW 0x002f**

Bit(s)	R/W	Default	Description
5:0			4*tCCD in LPDDR4 mask write.

**Table 12-199 DMC\_DRAM\_TESCKE 0x0030**

Bit(s)	R/W	Default	Description
5:0			tESCKE. enter self refresh to power time for LPDDR4.

Table 12-200 DMC\_DRAM\_TREFI\_DDR3 0x0031

Bit(s)	R/W	Default	Description
7:0			8*DDR3 SDRAM tREFI time . the unit is t100ns. use this to check in 8*tREFI time, the DMC should sent more than 16 auto REFRESH command.

DMC\_DRAM\_TZQCAL 0x0032

DMC\_DRAM\_T10US 0x0033

Table 12-201 DMC\_DRAM\_TMRR1 0x0034

Bit(s)	R/W	Default	Description
7:0			tMRR1 for MRR

DMC\_NFQ\_TMRD 0x0040

DMC\_NFQ\_TRFC 0x0041

DMC\_NFQ\_TRP 0x0042

DMC\_NFQ\_TRTW 0x0043

DMC\_NFQ\_TCL 0x0044

DMC\_NFQ\_TCWL 0x0045

DMC\_NFQ\_TRAS 0x0046

DMC\_NFQ\_TRC 0x0047

DMC\_NFQ\_TRCD 0x0048

DMC\_NFQ\_TRRD 0x0049

DMC\_NFQ\_TFAW 0x004a

DMC\_NFQ\_TRTP 0x004b

DMC\_NFQ\_TWR 0x004c

DMC\_NFQ\_TWTR 0x004d

DMC\_NFQ\_TCCD 0x004e

DMC\_NFQ\_TEXSR 0x004f

DMC\_NFQ\_TXS 0x0050

DMC\_NFQ\_TXP 0x0051

DMC\_NFQ\_TXPDLL 0x0052

DMC\_NFQ\_TZQCS 0x0053

DMC\_NFQ\_TCKSRE 0x0054

DMC\_NFQ\_TCKSRX 0x0055

DMC\_NFQ\_TCKE 0x0056

DMC\_NFQ\_TMOD 0x0057

DMC\_NFQ\_TDQS 0x0058

DMC\_NFQ\_TRSTL 0x0059

DMC\_NFQ\_TZQLAT 0x005a  
 DMC\_NFQ\_TMRR 0x005b  
 DMC\_NFQ\_TCKESR 0x005c  
 DMC\_NFQ\_TDPD 0x005d  
 DMC\_NFQ\_DFITCTRLDELAY 0x005e  
 DMC\_NFQ\_DFITPHYWRDATA 0x005f  
 DMC\_NFQ\_DFITPHYWRLAT 0x0060  
 DMC\_NFQ\_DFITRDDATAEN 0x0061  
 DMC\_NFQ\_DFITPHYRDLAT 0x0062  
 DMC\_NFQ\_DFITCTRLUPDMIN 0x0063  
 DMC\_NFQ\_DFITCTRLUPDMAX 0x0064  
 DMC\_NFQ\_DFITMSTRRESP 0x0065  
 DMC\_NFQ\_DFITREFMSKI 0x0066  
 DMC\_NFQ\_DFITCTRLUPDI 0x0067  
 DMC\_NFQ\_DFITDRAMCLK 0x0068  
 DMC\_NFQ\_DFITLPRESP 0x006a  
 DMC\_NFQ\_DFITPHYMSTR 0x006b  
 DMC\_NFQ\_TCKECK 0x006c  
 DMC\_NFQ\_TREFI 0x006d  
 DMC\_NFQ\_TSR 0x006e  
 DMC\_NFQ\_TCCDMW 0x006f  
 DMC\_NFQ\_TESCKE 0x0070  
 DMC\_NFQ\_TREFI\_DDR3 0x0071  
 DMC\_NFQ\_TZQCAL 0x0072  
 DMC\_NFQ\_T10US 0x0073  
 DMC\_NFQ\_TMRRI 0x0074  
 DMC\_DRAM\_DFITPHYUPDTYPE0 0x0080  
 DMC\_DRAM\_DFITPHYUPDTYPE1 0x0081  
 DMC\_DRAM\_DFITPHYUPDTYPE2 0x0082  
 DMC\_DRAM\_DFITPHYUPDTYPE3 0x0083

**Table 12-202 DMC\_DRAM\_DFIODTCFG 0x0084**

Bit(s)	R/W	Default	Description
12			rank1 ODT default. default value for ODT[1] pins if there's no read/write activity.
11			rank1 ODT write sel. enable ODT[1] if there's write occur in rank1.
10			rank1 ODT write nsel. enable ODT[1] if there's write occur in rank0.
9			rank1 odt read sel. enable ODT[1] if there's read occur in rank1.
8			rank1 odt read nsel. enable ODT[1] if there's read occur in rank0.

Bit(s)	R/W	Default	Description
4			rank0 ODT default. default value for ODT[0] pins if there's no read/write activity.
3			rank0 ODT write sel. enable ODT[0] if there's write occur in rank0.
2			rank0 ODT write nsel. enable ODT[0] if there's write occur in rank1.
1			rank0 odt read sel. enable ODT[0] if there's read occur in rank0.
0			rank0 odt read nsel. enable ODT[0] if there's read occure in rank1.

Table 12-203 DMC\_DRAM\_DFIODTCFG1 0x0085

Bit(s)	R/W	Default	Description
27:24			ODT length for BL8 read transfer.
19:16			ODT length for BL8 write transfer.
12:8.			ODT latency for reads. suppose to be 0.
4:0.			ODT latency for writes. suppose to be 0

Table 12-204 DMC\_DRAM\_MCFG 0x0086

Bit(s)	R/W	Default	Description
12			1: dbi inversion. 0: dbi high inversion.
11			1: dbi read enable. 0: dbi not enabled.
10			1: enable staggered chip select for 2 ranks DRAM.
9			1: enable send auto refresh command to DDR SDRAM when PCTL is in CFG/ STOP state.
8			send auto refr cmd before enter register triggered self refresh
4			send auto refr cmd after exit register triggered self refresh mode.
3			disable dram clock after enter register triggered self refresh.
2			send DFI_LP_REQ to PHY after enter register triggered elf refresh mode.
1			send DRAM to power down mode after enter self refresh. ONLY for LPDDR4.
0			send DFI_CTRLUPD_REQ after exit register triggered self refresh.

Table 12-205 DMC\_DRAM\_DFI\_CTRL 0x0089

Bit(s)	R/W	Default	Description
31			siu_dfi_lat err generation enable. 1: if dfi read latency violation, generate data error. 0 : disable.
30			DDR4 dfi_rddata_cs_n bug fix enable. 1 : enable the bug fix. 0 : not enable the bug fix. need modify phy register to remap the dfi_rddata_cs_n in ddr4 sdrum case.
20			siu_dfi1_phymstr_ack_en
19			siu_dfi_phymstr_req_and
18			siu_dfi_phymstr_req_or

Bit(s)	R/W	Default	Description
17			siu_dfi_phymstr_type_sel
16			siu_dfi_phymstr_cs_sel
15			siu_dfi1_lp_en
14			siu_dfi_lp_ack_and
13			siu_dfi_lp_ack_or
12			siu_dfi1_init_start_en
11			siu_dfi_init_com_and
10			siu_dfi_init_com_or
9			siu_dfi1_freq_en
8			siu_dfi1_dram_clk_dis_en
7			siu_dfi_phyupd_type_sel
6			siu_dfi1_phyupd_ack_en
5			siu_dfi_phyupd_req_and
4			siu_dfi_phyupd_req_or
3			siu_dfi_ctrlupd_ack_and
2			siu_dfi_ctrlupd_ack_or
1			siu_dfi1_ctrlupd_req_en
0			siu_dfi1_cmd_en

Table 12-206 DMC\_DRAM\_DFIINITCFG 0x008a

Bit(s)	R/W	Default	Description
31.			dfi_init_complete status. read only.
15:14			Frequency set 1 dfi_freq_ratio value.
12:8			Frequency set 1 dfi_freq value.
7:6			Frequency set 0 dfi_freq_ratio value.
5:1			Frequency set 0 dfi_freq value.
0.			dfi_init_start value can be use manually config dfi_init_start signal.

Table 12-207 DMC\_DRAM\_ZQ\_CTRL 0x008b

Bit(s)	R/W	Default	Description
2			send ZQCS command to RANK0 then send command to RANK1.
1			send ZQCS command to both RANK0 and RANK1 together.
0			send ZQCS command to only rank0.

**Table 12-208 DMC\_DRAM\_APD\_CTRL 0x008c**

Bit(s)	R/W	Default	Description
19:16			DFI_LP_WAKEUP value in APD DFI_LP_REQ mode
12			1: exit power down slow mode(waiting PLL LOCK). 0 : fast mode.
11			enable DFI_LP_REQ when enter Auto power down mode.
10			disable DFI_clk_disable when enter auto power down mode.

**Table 12-209 DMC\_DRAM\_ASR\_CTRL 0x008d**

Bit(s)	R/W	Default	Description
23:20			DFI_LP_WAKEUP value in self refresh DFI_LP_REQ mode.
17			send REFRESH command after exit from auto self refresh mode(ASR).
16			send REFRESH command before enter to Auto self refresh mode(ASR).
15			send ZQCS command after exit from Auto self refresh mode(ASR).
14			send dfi_ctrl_upd after exit from ASR mode
13			send power down command when enter ASR mode. for LPDDR4 only.
12			set the PHY enter LP2 mode after enter ASR mode.
11			send DFI_LP_REQ after enter ASR mode.
10			set DFI_CLK_DISABLE after enter ASR mode.
9:0			0 disable auto ASR mode.

DMC\_DRAM\_PHYMSTR\_CTRL 0x0090

Not used.

DMC\_DRAM\_DFIODTRANKMAP 0x0091

Not used.

**Table 12-210 DMC\_DRAM\_REFR\_CTRL 0x0092**

Bit(s)	R/W	Default	Description
17:8			auto refresh request pending cnt if there's page hit request.
6			Disabled auto refresh command if over 16 auto refresh command sent in 2 TRE-FI_DDR3 period
5			enable dmc send ZQCS command .
4			enable dmc send DFI_CTRUPD_REQ.
3:1			how many refresh command send for one period. = this number + 1
0			enable dmc send auto refresh command.

**Table 12-211 DMC\_DRAM\_FREQ\_CTRL 0x0093**

Bit(s)	R/W	Default	Description
31 .			Write 1 to change frequency read 0: finished.
30:9			Not used.
9.			1 : FREQ MRW done. Let FREQ change machine continue.
8			Freq wait. 1 when freq change finishes, state machine stop at self refresh state in case there's something need to handle.
7			When change PLL setting, disable dmc clock
6			When change PLL setting, disable PHY dficlck and dfictlck.
5			Check vpu_sleep_en ==1 when do FREQ change. If vpu_sleep_en == 0, just wait.
4			Nxt frequency selection. 1 = freq1. 0 = freq0.
3:1.			Not used.
0.			Current frequency selection.

**Table 12-212 DMC\_DRAM\_SCFG 0x0094**

Bit(s)	R/W	Default	Description
2:0			only one bit can be high at same time.
2			1 : to ask PCTL enter ACCESS STATE. 0 : deassert the request.
1			1 : to ask PCTL enter SELF REFRESH STATE. 0 : deassert the request.
0			1 : to ask PCTL enter STOP/CONFIG STATE . 0 : deassert the request.

**Table 12-213 DMC\_DRAM\_STAT 0x0095**

Bit(s)	R/W	Default	Description
27:23			dram_sr_state
22:20			stop_st
19:15			sleep_st
14:12			ACCESS STATUS 0 : ACCESS is in normal working mode.
11:8			APD STATUS: 0 : APD_IDLE
7:4			DRAM_STATUS: 0 : DRAM IDLE
3			Reserved.
2			1 : DRAM enter normal working state.
1			1 : DRAM enter sleep state. self refresh state.
0			1 : dram enter cfg state.

**Table 12-214 DMC\_DRAM\_STAT1 0x0096**

Bit(s)	R/W	Default	Description
11:8			freq_st.
7:5			train_st
4:0			dram_phy_st

**Table 12-215 DMC\_PHY\_RETRAINING\_CTRL 0x0097**

Bit(s)	R/W	Default	Description
31			phy_retraining enable.
30			check vpu sleep_en.
23:0			retraining period unit : 100ns.

**Table 12-216 DMC\_DFI\_ERR\_STAT 0x0098**

Bit(s)	R/W	Default	Description
31:20			not used.
9			ddr0_dfi_error
8:5			ddr0_dfi_error_info.
4			ddr1_dfi_error.
3:0			ddr1_dfi_error_info.

**Table 12-217 DMC\_LP2\_TIMER 0x009a**

Bit(s)	R/W	Default	Description
31			write 1 to initial a MRW command read 0 finished.
23:16			MR addr. DDR4 case : 18:16 ba[2:0]. 29:19 BG[1:0].
15:0			opcode.

**Table 12-218 DMC\_DRAM\_DFI\_SWAP\_0 0x00a0**

Bit(s)	R/W	Default	Description
5:0			dfi_act_n function select

**Table 12-219 DMC\_DRAM\_DFI\_SWAP\_1 0x00a1**

Bit(s)	R/W	Default	Description
5:0			dfi_ras_n function select



**Table 12-220 DMC\_DRAM\_DFI\_SWAP\_2 0x00a2**

Bit(s)	R/W	Default	Description
5:0			dfi_cas_n function select

**Table 12-221 DMC\_DRAM\_DFI\_SWAP\_3 0x00a3**

Bit(s)	R/W	Default	Description
5:0			dfi_we_n function select

**Table 12-222 DMC\_DRAM\_DFI\_SWAP\_4 0x00a4**

Bit(s)	R/W	Default	Description
5:0			dfi_bg0 function select

**Table 12-223 DMC\_DRAM\_DFI\_SWAP\_5 0x00a5**

Bit(s)	R/W	Default	Description
5:0			dfi_bg[1] function select

**Table 12-224 DMC\_DRAM\_DFI\_SWAP\_6 0x00a6**

Bit(s)	R/W	Default	Description
5:0			dfi_ba[0] function select

**Table 12-225 DMC\_DRAM\_DFI\_SWAP\_7 0x00a7**

Bit(s)	R/W	Default	Description
5:0			dfi_ba[1] function select

**Table 12-226 DMC\_DRAM\_DFI\_SWAP\_8 0x00a8**

Bit(s)	R/W	Default	Description
5:0			dfi_ba[2] function select

**Table 12-227 DMC\_DRAM\_DFI\_SWAP\_9 0x00a9**

Bit(s)	R/W	Default	Description
5:0			dfi_a[0] function select

**Table 12-228 DMC\_DRAM\_DFI\_SWAP\_10 0x00aa**

Bit(s)	R/W	Default	Description
5:0			dfi_a[1] function select

**Table 12-229 DMC\_DRAM\_DFI\_SWAP\_11 0x00ab**

Bit(s)	R/W	Default	Description
5:0			dfi_a[2] function select

**Table 12-230 DMC\_DRAM\_DFI\_SWAP\_12 0x00ac**

Bit(s)	R/W	Default	Description
5:0			dfi_a[3] function select

**Table 12-231 DMC\_DRAM\_DFI\_SWAP\_13 0x00ad**

Bit(s)	R/W	Default	Description
5:0			dfi_a[4] function select

**Table 12-232 DMC\_DRAM\_DFI\_SWAP\_14 0x00ae**

Bit(s)	R/W	Default	Description
5:0			dfi_a[5] function select

**Table 12-233 DMC\_DRAM\_DFI\_SWAP\_15 0x00af**

Bit(s)	R/W	Default	Description
5:0			dfi_a[6] function select

**Table 12-234 DMC\_DRAM\_DFI\_SWAP\_16 0x00b0**

Bit(s)	R/W	Default	Description
5:0			dfi_a[7] function select

**Table 12-235 DMC\_DRAM\_DFI\_SWAP\_17 0x00b1**

Bit(s)	R/W	Default	Description
5:0			dfi_a[8] function select

**Table 12-236 DMC\_DRAM\_DFI\_SWAP\_18 0x00b2**

Bit(s)	R/W	Default	Description
5:0			dfi_a[9] function select

**Table 12-237 DMC\_DRAM\_DFI\_SWAP\_19 0x00b3**

Bit(s)	R/W	Default	Description
5:0			dfi_a[10] function select

**Table 12-238 DMC\_DRAM\_DFI\_SWAP\_20 0x00b4**

Bit(s)	R/W	Default	Description
5:0			dfi_a[11] function select

**Table 12-239 DMC\_DRAM\_DFI\_SWAP\_21 0x00b5**

Bit(s)	R/W	Default	Description
5:0			dfi_a[12] function select

**Table 12-240 DMC\_DRAM\_DFI\_SWAP\_22 0x00b6**

Bit(s)	R/W	Default	Description
5:0			dfi_a[13] function select

**Table 12-241 DMC\_DRAM\_DFI\_SWAP\_23 0x00b7**

Bit(s)	R/W	Default	Description
5:0			dfi_a[14] function select

**Table 12-242 DMC\_DRAM\_DFI\_SWAP\_24 0x00b8**

Bit(s)	R/W	Default	Description
5:0			dfi_a[15] function select

**Table 12-243 DMC\_DRAM\_DFI\_SWAP\_25 0x00b9**

Bit(s)	R/W	Default	Description
5:0			dfi_a[16] function select

**Table 12-244 DMC\_DRAM\_DFI\_SWAP\_26 0x00bb**

Bit(s)	R/W	Default	Description
5:0			dfi_a[17] function select

The following registers' base address is 0xff638800. Each register takes 4 byte address.

Each register's final address = 0xff638800 + offset \* 4.

DMC\_STICKY\_0 0x0000

DMC\_STICKY\_1 0x0001

DMC\_STICKY\_2 0x0002  
DMC\_STICKY\_3 0x0003  
DMC\_STICKY\_4 0x0004  
DMC\_STICKY\_5 0x0005  
DMC\_STICKY\_6 0x0006  
DMC\_STICKY\_7 0x0007  
DMC\_STICKY\_8 0x0008  
DMC\_STICKY\_9 0x0009  
DMC\_STICKY\_10 0x000a  
DMC\_STICKY\_11 0x000b  
DMC\_STICKY\_12 0x000c  
DMC\_STICKY\_13 0x000d  
DMC\_STICKY\_14 0x000e  
DMC\_STICKY\_15 0x000f  
DMC\_STICKY\_16 0x0010  
DMC\_STICKY\_17 0x0011  
DMC\_STICKY\_18 0x0012  
DMC\_STICKY\_19 0x0013  
DMC\_STICKY\_20 0x0014  
DMC\_STICKY\_21 0x0015  
DMC\_STICKY\_22 0x0016  
DMC\_STICKY\_23 0x0017  
DMC\_STICKY\_24 0x0018  
DMC\_STICKY\_25 0x0019  
DMC\_STICKY\_26 0x001a  
DMC\_STICKY\_27 0x001b  
DMC\_STICKY\_28 0x001c  
DMC\_STICKY\_29 0x001d  
DMC\_STICKY\_30 0x001e  
DMC\_STICKY\_31 0x001f  
DMC\_STICKY\_32 0x0020  
DMC\_STICKY\_33 0x0021  
DMC\_STICKY\_34 0x0022  
DMC\_STICKY\_35 0x0023  
DMC\_STICKY\_36 0x0024  
DMC\_STICKY\_37 0x0025  
DMC\_STICKY\_38 0x0026  
DMC\_STICKY\_39 0x0027

DMC\_STICKY\_40 0x0028  
DMC\_STICKY\_41 0x0029  
DMC\_STICKY\_42 0x002a  
DMC\_STICKY\_43 0x002b  
DMC\_STICKY\_44 0x002c  
DMC\_STICKY\_45 0x002d  
DMC\_STICKY\_46 0x002e  
DMC\_STICKY\_47 0x002f  
DMC\_STICKY\_48 0x0030  
DMC\_STICKY\_49 0x0031  
DMC\_STICKY\_50 0x0032  
DMC\_STICKY\_51 0x0033  
DMC\_STICKY\_52 0x0034  
DMC\_STICKY\_53 0x0035  
DMC\_STICKY\_54 0x0036  
DMC\_STICKY\_55 0x0037  
DMC\_STICKY\_56 0x0038  
DMC\_STICKY\_57 0x0039  
DMC\_STICKY\_58 0x003a  
DMC\_STICKY\_59 0x003b  
DMC\_STICKY\_60 0x003c  
DMC\_STICKY\_61 0x003d  
DMC\_STICKY\_62 0x003e  
DMC\_STICKY\_63 0x003f

## 12.2 NAND

### 12.2.1 Overview

This part describe the SOC's SLC/MLC/TLC NAND Flash with 60-bit ECC.

### 12.2.2 Features

The features of SPI NAND are as follows.

- Industry-standard serial peripheral interface.
- Internal ECC parity(BCH-8/BCH-4).
- Density: 1Gbit/2GBits/4Gbits
- 2x/4x bus mode supported

## 12.2.3 Descriptor Commands

### Command “Standby”

All CEs are high, all other signals are “don’t care”, the bits [9:0] specify how many extra NAND cycles the controller stays in “standby”, if the number is “0”, only one NAND cycle, if the number is 10, the controller will stay in “standby” for 11 NAND cycles.

### Command “Idle”

CE is low, ALE and CLE is low, WE and RE is high, the NAND bus is taken over by controller, but the bus is let to idle for one NAND cycle, if extra NAND cycles number is set, then extra NAND cycles is idled, useful when NAND controller needs time to switch to another mode, or wait for RB.

### Command “Command”

NAND command is sent, CE is low, ALE is low, CLE is high, WE is low and RE is high, usually only one NAND CE is low, all the other 3 should be high, otherwise the NAND command is accepted by multiple Dies and may cause conflict problem, but it is fine when used to reset the NAND, the command itself is sent by bit 7 to bit 0, one command sends one NAND command.

### Command “Address”

NAND address cycle, the CE is low, ALE is high, CLE is low, WE is low and RE is high. Usually only one NAND CE is low, all the other 3 CEs should be high. The address is sent in the bit 7 to bit 0, it lasts one NAND cycle.

### Command “Data to NAND”

Write NAND bus directly by this command, CE is low, ALE and CLE are low, WE is low and RE is high, the low bit7 to bit 0 is write to NAND flash when this command is done, it lasts one NAND command cycle. Usually used to program NAND features, it is very low efficient to program NAND by this command, could be used to debug NAND flash software.

### Command “NAND to Data”

Read NAND bus and save the data to registers, CE is low, ALE and CLE are low, WE is high and RE is low, the NAND output is locked in registers at perfect timing, the extra NAND cycles will make this command repeats extra NAND cycle, if it is “0”, only one byte is locked in registers, since the registers used to lock the data is only 32 bits, extra NAND cycles number larger than 3 will cause the data overflow. This command is used to read status and features from NAND, not for read NAND data, it is very low efficient to read NAND by this command, it could be used to debug NAND software.

### Command “Sync Read”

Same as “NAND to Data”, used in synchronous mode, each NAND cycle will read in two bytes in synchronous mode.

### Command “RB pin”

Hardware ready/busy detect with timer and interrupt, the timer is bit 4 to bit 0, it is power of 2 NAND cycle, for example, if timer is set to 10, then  $2^{10}$  or 1024 NAND cycles is set to timer out the RB command. The maximum setting is 31, that is  $2^{31}$  NAND cycles. Or 42 seconds when NAND cycle is 20 ns. When the RB waiting is timed out, the hardware is still in “waiting”, an interrupt is sent to CPU, the “RB” command can be programmed to send out interrupt when RB is high when the correspond INT bits is set to high, once RB is high, the command queue advanced to next command, no matter interrupt or not, interrupt setting is “one time setting”, it means one RB command can be programmed with interrupt, the next can be programmed without interrupt. There are few bits in the RB command for software debugging purpose. it can be set to different numbers to tell which RB command is interrupted. CPU can read out the NAND status registers to tell which RB causes interrupt.

## Command “RB IO”

Assume the NAND controller is used without ready/busy pin, the ready/busy is checked through status register, This command should be used with NAND read status command, like the old RB command, this command is designed with option to check which IO bits as ready/busy, “IO6”, “IO5” and “IO4”, and “INT6”, “INT5” and “INT4” to issue “IRQ” if “Ready”, time out logic is the same as old RB, in case of “Read” NAND, an extra “0x00” command is needed to switch NAND flash back to “Read” mode.

The RB IO command is associated with CE state, there is no CE option in RB IO command, valid CE from previous command is used.

NAND status is checked every 16 NAND cycles, if not ready when time out, an “IRQ” is issued and timer is reset.

Change to read status mode.

Set proper timer out parameter.

Monitor which IO bits, IO6, IO5 or IO4.

Set IRQ option, set NAND\_CFG cmd\_irq\_en bit.

Return back to read mode if needed.

## Command “MEM to NAND”

DMA command to send data from memory to NAND, this command consist of ECC mode, the data is read from DDR memory by NAND controller at 64 bits/system cycle, BCH encoded by hardware and sent to NAND in the fly. The NAND data address can be programmed by register or command “set address”.

The data size can be any number, if ECC is off, the exact number of data bytes are read from DDR memory and sent to NAND without ECC encode, if ECC is on, and final page is not 512 bytes, then “0xff” is appended to the data to make it 512 bytes and send to BCH encoded and send to NAND.

When ECC is off, no spare data bytes are read from DDR, the data is sent exactly the same as DDR. When ECC is on, 2/16/0 bytes of spare bytes are read from DDR and appended to 512/1024 main data, encoded and parity bytes all sent to NAND.

The final BCH code word is rounded to integer number of bytes, see BCH table.

If ECC is OFF, the command writes [13:0] number of bytes to NAND.

If ECC is ON, the command writes “pages” of bytes to NAND.

If “short” is 0, the page size is BCH code data size, 512 or 1024.

If “short” is 1, shortened BCH mode, the page size is “page size”\*8 bytes.

The number of pages is up to 63.

Data randomization option, if cmd[19] is set to “1” and the random seed is not equal to “0”, the data and parity written to NAND is randomized with PRBS random number, the same seed must be used to read the page back.

Random seed is set by command “Seed” cmd[14:0], suggest to use NAND physical address as “seed”.

## Command “NAND to MEM”

DMA command to read data from NAND and save to DDR, this command consist of ECC mode, and data size, this command will correct the data by hardware and save the decode result information to DDR too. The data address in DDR is programmed by “set address” command, if not programmed the address increases to next available data space.

When ECC is off, the data is save to DDR without change, the information bytes is also saved in DDR with ECC mode bits off, no spare bytes, when ECC is on, the data is BCH decoded and corrected by

hardware, if the data size is less than 512/1024, more data will be read out from NAND, but only the required number of bytes are sent to DDR.

If ECC is OFF, the command reads [13:0] number of bytes from NAND.

If ECC is ON, the command reads “pages” of bytes to NAND.

If “short” is 0, the page size is BCH code data size, 512 or 1024.

If “short” is 1, shortened BCH mode, the page size is “page size”\*8 bytes.

The number of pages is up to 63.

Data randomization option is the same as “MEM to NAND”.

### Command “Set Address”

DDR address setup command, used to change the memory address when read or write NAND, the D/S bits is for data or spare, “0” for data, “1” for spare, L/H is for low and high 16 bits of address, “0” for low 16 bits, “1” for high 16 bits, the DDR address is 32 bits.

This command has nothing to do with NAND bus, but it will take one NAND command to execute, one NAND idle command is used in time.

Mode	Cmd[18:17]	Description
Data	00	Set Data Address
Info	01	Set Info Address
Status	10	Set Status Address

### Command “STS”

Read status and save to DDR memory, the status registers is 32 bits, with

Field	Name	Description
15:0	Sts	Status
23:16	Sts counter	Sequence number
31	Done	This status is valid.

STS 1: read status once, without IRQ.

STS 2: read status twice, with IRQ.

If NAND\_CFG[20] Sts\_irq\_en is set to “1”, the STS 2 command will issue an IRQ to system, if used after NAND read command “N2M”, it guarantees the DMA is done. Because the STS itself is a DMA command, it will wait till the previous DMA command done before its DMA.

STS 2 command resets the sequence number, the sequence number in itself is the number of STS 1’s before IRQ, wrap around to 8 bits.

### Command “Set Seed”

Random seed for data randomizer, any number except 0 starts random number generator, if “N2M” or “M2N” random bit is set, the random number is XORed with data.

Set none zero random seed, in cmd[14:0].

Set cmd[19] of “N2M” or “M2N” to 1, enable scrambler.

Use same seed to program/read the same NAND page.



## 12.2.4 Register Description

The base address of NAND registers is 0xffe07000, and the final address of each register is listed below.

**Table 12-245 NAND Register List**

Register Name	Description	Address	R/W
P_NAND_CMD	Write Command and Read Status	Base + 0x00	R/W
P_NAND_CFG	Configuration	Base + 0x04	R/W
P_NAND_DADR	Data Address	Base + 0x08	R/W
P_NAND_IADR	Information Address	Base + 0x0c	R/W
P_NAND_BUF	Read Data Buffer	Base + 0x10	R
P_NAND_INFO	Information	Base + 0x14	R
P_NAND_DC	DDR interface	Base + 0x18	R
P_NAND_ADR	DDR Address	Base + 0x1c	R
P_NAND_DL	DDR Low 32 Bits Data	Base + 0x20	R/W
P_NAND_DH	DDR High 32 Bits Data	Base + 0x24	R/W
P_NAND_CADR	Command Queue Address	Base + 0x28	R/W
P_NAND_SADR	Status Address	Base + 0x2c	R/W
P_NAND_PINS	CS2: SDRAM/NAND pin sharing	Base + 0x30	R/W
P_NAND_VER	Version number	Base + 0x38	R

### P\_NAND\_CMD

**Write :** Send NAND command to controller, the command format is specified in previous section.

Bit(s)	Name	Description
21:0	Cmd	NAND command sent to NAND queue buffer
30	Cmd_go	When 1, and NAND bus is in waiting Rb mode, due to time out or longer than expected Rb waiting, the command queue will move on by disable RB waiting in current command.
31	Cmd_reset	When 1 the NAND command queue buffer is reset to zero.

**Read :** Read NAND controller status

Bit(s)	Name	Description
19:0	Cmd_curr	NAND command current on NAND bus, still going, not finished.
24:20	Cmd_cnt	Number of NAND commands still in NAND command queue buffer, the buffer size is 32.
25	Timer out	When 1 wait Rb command timed out.
26	Rb0	Current Rb0 status, 1: ready, 0: busy.
27	Rb1	Current Rb1 status, 1: ready, 0: busy.

Bit(s)	Name	Description
28	Rb2	Current Rb2 status, 1: ready, 0: busy.
29	Rb3	Current Rb3 status, 1: ready, 0: busy.
30	Mem_rdy	When 1, DDR interface is idle and ready to accept memory movement request.
31	Ecc_rdy	When 1, ECC BCH encoder/decoder is idle and read to accept encode or decode activity.

## P\_NAND\_CFG

Bit(s)	Name	Description
4:0	Bus_cyc	The number of system clock cycles in one NAND cycle – 1, for example, if the bus_cyc is 3, then the NAND cycle is 4 system clock cycles, the minimum setting is 3, the maximum setting is 31. program this register according NAND timing mode.
9:5	Bus_tim	The timing to lock the NAND data when read NAND data or status, please refer to “Timing Calculator” for details.
11:10	Sync	00: Async mode 01: Micron Sync mode 10: Toshiba-Samsung toggle mode
12	Cmd_start	When set to “1”, if the NAND controller internal 32 command buffer has less than 16 commands, the command DMA starts reading commands from DDR and saves them to internal buffer, the DMA keeps watching the internal buffer, reads whenever there are less than 16 commands left, if an all “zero” command is met, This bit is cleared and current command DMA is done.
13	Cmd_auto	When set to ‘1’, the command DMA will check the previous command queue end location, whether it is changed from all “zero” back to valid command, the auto check period is 1 ms.
14	Apb_mode	Special NAND mode for ROM boot or debug, when 1, DDR interface is redirected to APB register, all the read/write activities are through APB registers. When used in ROM boot and DDR is not ready.
15	Spare_only	When 1, the NAND controller read NAND with/without ECC, but only save the information bytes into DDR memory, the main data is discarded, designed for software to survey the NAND flash spare bytes and prepare NAND programming.
16	Sync_adj	Used to adjust data timing in sync or toggle mode, 0: default timing, 1: delay 1 system clock cycle.
20	Sts_irq_en	Enable STS IRQ.
21	Cmd_irq_en	Enable RB pin or RB IO IRQ.
26	Oob_on	Set to 1 oob_mode 16/0, Set to 0 no oob bytes.
27	Oob_mode	New in M8 v2, Set to 1 enable new oob mode. First page 16 bytes, all other pages 0 byte.
28	Dc_ugt	Set NAND controller DDR interface to Urgent mode.
29	Nand_wpn	When 1, the NAND wpn pin is set to low, the NAND is in write protection mode, default to 0, the NAND is not protected.

Bit(s)	Name	Description
30	Core_power	When 1, internal NAND controller core clock gating is override to always on. The clock gating is disabled.
31	Top_power	When 1, internal NAND top clock gating is override to always on, the clock gating for top is disabled.

### P\_NAND\_DADR

Set DDR data address by registers, the address is 32 Bits, since the DDR data address can also be set by NAND commands, when both happens at the same time, register setting is ignored, the NAND command setting takes effect. Software should avoid conflict address setting.

### P\_NAND\_IADR

Set DDR information (spare bytes) address by registers, the address is 32 Bits, since the DDR information address can also be set by NAND commands, when both happens at the same time, register setting is ignored, the NAND command setting takes effect. Software should avoid conflict address setting.

### P\_NAND\_BUF

When read NAND status, features or data, the results are buffer in this register, the register is 32 Bits, it can only hold 4 bytes, if the host not doesn't read out the results, it will be over written by the following "read".

### P\_NAND\_INFO

One 32 Bits information per each 512 bytes in ECC mode.

Bit(s)	Name	Description
7:0	Info 0	Information (spare) byte 0, errors already corrected by BCH.
15:8	Info 1	Information (spare) byte 1, errors already corrected by BCH
21:16	Pages	Count down page number in current DMA read, starts from the total page size, count down to 1.
28:24	Errcnt	Number of errors corrected by BCH in current page, 0 means no error in current page, 0x1f means this page is uncorrectable.
29	Unc	When 1, this page is uncorrectable by BCH, this page is bad.
30	Ecc	When 1, current NAND read is with ECC on.
31	Done	When 1, the information content and data read from NAND are valid, otherwise the "read" is not done.

### P\_NAND\_DC

Used for apb\_mode, internal NAND controller still uses DDR interface, only the DDR request and DDR grant are redirected from DDR to apb registers, this enables the host to read NAND without DDR, for ROM boot and debug.

Bit(s)	Name	Description
7:0	Dc_wr_dm	DDR write data mask, Each Bit masks one byte.
8	Dc_wr	When 1, write data from NAND to DDR. When 0, read data from DDR to NAND.
9	Dc_lbrst	When 1, the 64 Bits data is the last in current DDR burst, used with Dc_req.

Bit(s)	Name	Description
10	Dc_ugt	When 1, current DDR request of read/write is urgent, in NAND controller, the Dc_ugt is set to 0, none-urgent.
11	Dc_req	When 1, the NAND controller send request to DDR to read or write data, in case of apb_mode, when dc_req is "1", the host is responsible for send to or receive from NAND controller. Note: this is the only signal the host needs to check when in apb_mode.

## P\_NAND\_ADR

32 Bits DDR address when NAND controller read or write to DDR memory, any address space within the DDR memory installed in the system is valid.

## P\_NAND\_DL

The DDR interface uses 64 Bits width bus, this register is for low 32 Bits, [31:0].

## P\_NAND\_DH

The DDR interface uses 64 Bits width bus, this register is for high 32 Bits, [63:32].

Read and write to this register will generate "grant" and "dc\_wr\_avail" or "dc\_rd\_avail".

Always read or write low 32 Bits first, then read or write to high 32 Bits and NAND controller hardware will generate "grant" and "dc\_wr\_avail" or "dc\_rd\_avail", combined with the data, the DDR address advances to next address.

NAND controller programs NAND flash in apb\_mode:

- Check P\_NAND\_DC till "dc\_req" is high.
- Write low 32 Bits to P\_NAND\_DL.
- Write high 32 Bits to P\_NAND\_DH.
- Go back to beginning till all the data is written.

NAND controller reads data from NAND flash in apb\_mode:

- Check P\_NAND\_DC till "dc\_req" is high.
- Read low 32 Bits from P\_NAND\_DL.
- Read high 32 Bits from P\_NAND\_DH.
- Go back to beginning till all the data is read.

Since the DDR interface in NAND controller process the data in group of 16 double words (64 Bits), the software can only check "dc\_req" at the beginning of each 16 double words.

## P\_NAND\_CADR

Set command queue memory address, 32 Bits, any memory location.

This address can only be programmed by APB bus.

## P\_NAND\_SADR

Set status memory location, 32 Bits, any memory location.

This address can also be programmed through command queue.

## P\_NAND\_PINS

Bit(s)	Name	Description
13:0	Pins_len	When pins are acquired by NAND, it will use Pins_len number of NAND bus cycles before releasing pins. Default is 8.
27:14	Pins_off	When pins are released by NAND, it will wait Pins_off number of NAND bus cycles before sending next request. Default is 2.
31	Not shared	When 1 the pins is not shared, default is 0, pins are shared.

## 12.3 eMMC/SD

### 12.3.1 Overview

The SoC has the following features of eMMC/SD.

- Supports SDSC/SDHC/SDXC card
- Supports eMMC and MMC card specification version 5.0 up to HS200 with data content TDES crypto
- 1 bit, 4 Bits, 8 Bits data lines supported (8 Bits only for MMC)
- Descriptor chain architecture, timing tuning and adjustment
- Supports descriptor-based internal DMA controller

This module uses eMMC/SD CONTROLLERS to connect varied SD/MMC Card, or eMMC protocol compatible memory with high throughput.

### 12.3.2 Pin Description

Table 12-246 Pin Description of eMMC/SD/SDIO Module

Name	Type	Description	Speed (MHz)
CLK	Output	SD eMMC clock, 0~200MHz	200
DS	DS Data strobe for eMMC HS400 mode	-	-
DAT[7:0]	SD Card 4 Bits, eMMC 8 Bits Input/Output/Push-Pull Internal pull-up for pins not used	Data, 1,4,8 mode	200
CMD	Input/Output/Push-Pull/Open-Drain Open-drain for initialization Push-pull for fast command transfer ROD is connected when in open-drain mode.	Command Response	200
Rst_n	eMMC required	Hardware reset	Low
IRQ	SD Card or eMMC not used.	Device interrupt can be replaced by DAT[1]	Low

### 12.3.3 eMMC/SD Mode

#### eMMC Mode

Table 12-247 eMMC Mode

Mode Name	Data Rate	IO Voltage	Bus Width	Frequency	Max Data Transfer
Legacy MMC card	Single	3/1.8V	1, 4, 8	0-26MHz	26MB/s
High Speed SDR	Single	3/1.8V	1,4, 8	0-52MHz	52MB/s
High Speed DDR	Dual	3/1.8V	4, 8	0-52MHz	104MB/s
HS200	Single	1.8V	4, 8	0-200MHz	200MB/s

The HS200 mode offers the following features:

- SDR Data sampling method
- CLK frequency up to 200MHz Data rate – up to 200MB/s
- 4 or 8-bits bus width supported
- Single ended signaling with 4 Drive Strengths
- Signaling levels of 1.8V
- Tuning concept for Read Operations

#### SD Mode

Table 12-248 SD Mode

Mode Name	Data Rate	IO Voltage	Bus Width	Frequency	Max Data Transfer
Default Speed	Single	3.3V	1, 4	0-25MHz	12.5MB/s
High Speed	Single	3.3V	1, 4	0-50MHz	25MB/s
SDR12	Single	1.8V	1,4	0-25MHz	12.5MB/s
SDR25	Single	1.8V	1,4	0-50MHz	25MB/s
SDR50	Single	1.8V	1,4	0-100MHz	50MB/s
SDR104 (highest)	Single	1.8V	1,4	0-208MHz	104MB/s
DDR50	Dual	1.8V	4	0-50MHz	50MB/s

### 12.3.4 Descriptor

#### Structure

The descriptor has a size of 4x32 Bits.

Table 12-249 Descriptor Structure

byte	7	6	5	4	3	2	1	0
0	length[7:0]							
1	Timeout 4 Bits				End of chain	R1b	block mode	length[8]
2	data num	resp num	resp 128	resp nocrc	Data wr	Data io	No cmd	No resp
3	owner	error	cmd index 6 Bits					
4	cmd argument 32 Bits							
5								
6								
7								
8	data address 32 Bits or data 0-4 bytes [1]Big Endian, [0]SRAM							
9								
10								
11								
12	response address 32 Bits or response irq en [0]SRAM							
13								
14								
15								

### Definition

Name	Bits	Description
Length	Cmd_cfg[8:0]	same as spec, copy the content from command argument into this field, different byte size and 512 bytes, different number of blocks and infinite blocks. If the command is operating on bytes, block mode = 0, this field contains the number of bytes to read or write, A value of 0 shall cause 512 bytes to be read to written, if the command is operating on blocks, block mode = 1, this field contains the number of blocks, a value of 0 is infinite number of blocks.
Block_mode	Cmd_cfg[9]	1: the read or write shall be performed on block basis. The block size is from SD/eMMC device, and saved in APB3 register in module. 0: the read or write is byte based.
R1b	Cmd_cfg[10]	1: check the DAT0 busy after received response R1 0: do not check the DAT0 busy state.
End_of_chain	Cmd_cfg[11]	1: it is the end of descriptor chain, the host stops and issues IRQ after this descriptor is done. 0: the host reads next descriptor and continues. The command chain execution is started by write an APB3 register and stopped by the "end of chain" or clear a APB3 start register, or found one descriptor with owner is set to 0.
Timeout	Cmd_cfg[15:12]	2timeout ms when timeout != 0, max timeout 32.768s, when over the timeout limit, error bit is set, IRQ is issued. When timeout is 0, no time limit.
No_resp	Cmd_cfg[16]	1: this command doesn't have response, used with command doesn't have response. 0: there is a response. The module waits for response, the response time-out setting is in APB3 register.

Name	Bits	Description
No_cmd	Cmd_cfg[17]	1: this descriptor doesn't have command in it, it does data DMA only, used with command to read or write SD/eMMC with data from multiple locations.
Data_io	Cmd_cfg[18]	1: there is data action in this descriptor, used with command have data process. 0: there is no data read/write action.
Data_wr	Cmd_cfg[19]	1: host writes data to SD/eMMC 0: host read data from SD/eMMC
Resp_nocrc	Cmd_cfg[20]	1: R3 response doesn't have CRC. 0: host does CRC check.
Resp_128	Cmd_cfg[21]	1: R3 response with 128 Bits information. 0: 32 Bits responses.
Resp_num	Cmd_cfg[22]	1: the resp_addr is the IRQ enable Bits, used to check the response error status, when there is an error, IRQ[14] is issued, the first 4 bytes of response is saved into resp_addr. 0: save response into SRAM or DDR location.
Data_num	Cmd_cfg[23]	1: save 4 bytes of data back into descriptor itself at bytes 8~11.
Cmd_index	Cmd_cfg[29:24]	The SD/eMMC command index. Desc REG wr: 4 reg44, 12 reg4c.
Error	Cmd_cfg[30]	Write back by host. The combined error from command, response, data, includes CRC error and timeout. When it is set the descriptor execution is stopped and an IRQ is issued. The CPU can read SD_EMMC_STATUS register to get detail information.
Owner	Cmd_cfg[31]	Programmed by CPU to 1, cleared by host to 0. 1: the descriptor is valid and owned by host, after it is done, even it has error, the owner bit is cleared, the descriptor is owned by CPU. In case of descriptor chain execution when host found a descriptor with "0" owner bit, it will stop.
Cmd_arg	Desc 4~7 bytes	32 Bits. The actual command argument some of the previous fields are copied from this command argument, the software need to make sure they are consistent. Desc REG wr: new value Data_addr: write mask, 1: change, 0: no change.
Data_addr	Desc 8~11 bytes	32 Bits. If the data_num is 0, the content is data address. If the data_num is 1, this content is 4 data bytes. When it is an address: Data_addr[0]: 1: SRAM address, 0: DDR address. If the data_addr[31:12] matches with SD_EMMC_BASE, it is SRAM address. Data_addr[1]: 1: 4 bytes big endian, 0: little endian(default).
Resp_addr	Desc 12~15 bytes	32 Bits If the resp_num is 0, the content is resp address. If the resp_num is 1, before execution, it is the response IRQ enable Bits, after execution, it is the first 4 response bytes. When it is an address: Resp_addr[0]: 1: SRAM address, 0: DDR address. If the resp_addr[31:12] matches with SD_EMMC_BASE, it is SRAM address.



### 12.3.5 Register Description

Each register final address = module base address+ address \* 4

Where module address addresses are 0xFFE07000 for portB (eMMC), 0xFFE05000 for port C (eMMC).

**Table 12-250 SD\_EMMC\_CLOCK 0x0**

Bit(s)	R/W	Default	Description
30	R/W	0	Cfg_irq_sdio_sleep_ds : 1: select DS as IRQ source during sleep.
29	R/W	0	Cfg_irq_sdio_sleep: 1: enable IRQ sdio when in sleep mode. When DAT1 IRQ, the controller uses PCLK to detect DAT1 level and starts core clock, the core initials IRQ_period and detect DAT1 IRQ.
28	R/W	0	Cfg_always_on: 1: Keep clock always on 0: Clock on/off controlled by activities. Any APB3 access or descriptor execution will turn clock on. Recommended value: 0
27:22	R/W	0	Cfg_rx_delay: RX clock delay line, 6 bits 0: no delay, n: delay n*50ps Maximum delay 3150ps.
21:16	R/W	0	Cfg_tx_delay: TX clock delay line, 6 bits 0: no delay, n: delay n*50ps Maximum delay 63*50ps =3150ps.
15:14	R/W	0	Cfg_sram_pd: Sram power down
13:12			Cfg_rx_phase: RX clock phase 0: 0 phase, 1: 90 phase, 2: 180 phase, 3: 270 phase. Recommended value: 0
11:10	R/W	0	Cfg_tx_phase: TX clock phase 0: 0 phase, 1: 90 phase, 2: 180 phase, 3: 270 phase. Recommended value: 2
9:8	R/W	0	Cfg_co_phase: Core clock phase 0: 0 phase, 1: 90 phase, 2: 180 phase, 3: 270 phase. Recommended value: 2
7:6	R/W	0	Cfg_src: Clock source 0: Crystal 24MHz or other frequencies selected by clock reset test control register. 1: Fix PLL, 1000MHz Recommended value: 1
5:0	R/W	0	Cfg_div: Clock divider Frequency = clock source/cfg_div Clock off: cfg_div==0, the clock is disabled Divider bypass: cfg_div==1, clock source is used as core clock without divider Maximum divider 63.

**Table 12-251 SD\_EMMC\_DELAY1 0x4**

Bit(s)	R/W	Default	Description
31:30	R/W	0	Reserved.
29:24	R/W	0	Dly[4]: Data 4 delay line
23:18	R/W	0	Dly[3]: Data 3 delay line
17:12	R/W	0	Dly[2]: Data 2 delay line
11:6	R/W	0	Dly[1]: Data 1 delay line
5:0	R/W	0	Dly[0]: Data 0 delay line Total delay = 50ps * Dly When Dly == 0, no delay. When Dly ==63, 3150ps delay. NOTE: the 50ps is typical delay, actually delay may vary from chip to chip, from different temperature.

**Table 12-252 SD\_EMMC\_DELAY2 0x8**

Bit(s)	R/W	Default	Description
31:30			Reserved.
29:24			Dly[9]: Data 9 delay line
23:18			Dly[8]: Data 8 delay line
17:12			Dly[7]: Data 7 delay line
11:6			Dly[6]: Data 6 delay line
5:0			Dly[5]: Data 5 delay line Total delay = 50ps * Dly When Dly == 0, no delay. When Dly ==63, 3150ps delay. NOTE: the 50ps is typical delay, actually delay may vary from chip to chip, from different temperature.

**Table 12-253 SD\_EMMC\_ADJUST 0xc**

Bit(s)	R/W	Default	Description
31:23			Unused
22	R/W	0	Adj_auto 1: Use cali_dut's first falling edge to adjust the timing, set cali_enable to 1 to use this function, simulation shows it can tracking 2.5ns range with 800ppm. 0: disable Working for HS200 mode, set Cali_enable to 1. Enhanced after gx1x project. Use RESP and DAT0 as reference, Separate RESP and DAT0, adjust the timing whenever there is a transition, insert a sample when there is no transition.
21:16	R/W	0	Adj_delay: Resample the input signals when clock index==adj_delay
15	R/W	0	Reserved
14	R/W	0	Cali_rise: 1: test the rising edge, recording rising edge location only. 0: test the falling edge
13	R/W	0	Adj_fixed: Adjust interface timing by resampling the input signals
12	R/W	0	Cali_enable: 1: Enable calibration 0: shut off to save power.
11:8	R/W	0	Cali_sel: Select one signal to be tested Signals are labeled from 0 to 9 the same as delay lines. Only one signal is tested at anytime. For example: Cali_sel == 9, test CMD line.

**Table 12-254 SD\_EMMC\_CALOUT 0x10**

Bit(s)	R/W	Default	Description
31:16			Unused
15:8	R		Cali_setup
7	R		Cali_vld: The reading is valid When there is no rising edge or falling edge event, the valid is low, this reading is not valid.
5:0	R		Cali_idx: The event happens at this index, The index starts from rising edge of core clock from 0, 1, 2, ...

**Table 12-255 SD\_EMMC\_ADJ\_IDX\_LOG 0x20**

Bit(s)	R/W	Default	Description
31:30			Current, Auto_adj mode, Current 6 bits adj_idx
29:24			Previous 1
23:18			Previous 2
17:12			Previous 3
11:6			Previous 4
5:0			Previous 5: Last two bits of previous 5

**Table 12-256 SD\_EMMC\_CLKTEST\_LOG 0x24**

Bit(s)	R/W	Default	Description
31			Clktest_done, Test done
30:0			Clktest_times, Test clock core for 2^Clktest_exp

**Table 12-257 SD\_EMMC\_CLKTEST\_OUT 0x28**

Bit(s)	R/W	Default	Description
31:0			Clktest_out, All 2^clktest_exp test results add up. Note: divided by 2^clktest_exp and get average clock core period length measured by 50ps delay cells.

**Table 12-258 SD\_EMMC\_EYETEST\_LOG 0x2c**

Bit(s)	R/W	Default	Description
31			eyetest_done, Test done
30:0			eyetest_times, Test eye for 2^eyetest_exp

**Table 12-259 SD\_EMMC\_EYETEST\_OUT0 0x30**

Bit(s)	R/W	Default	Description
31:0			All 2^eyetest_exp test results "OR" together.

**Table 12-260 SD\_EMMC\_EYETEST\_OUT1 0x34**

Bit(s)	R/W	Default	Description
31:0			eyetest_out1, All 2^eyetest_exp test results "OR" together. Total eyeout [62:0] = {Eyetest_out1[30:0], eyetest_out0[31:0]} EYEtest output changed to 64 bits after TXLX and A113 {eyetest_out1, eyetest_out0}

Table 12-261 SD\_EMMC\_INTF3 0x38

Bit(s)	R/W	Default	Description
26			Eyetest_sel, 0 : select core clock as eyetest clock. 1 : select DS after delay line as eyetest clock. Eyetest point is DS after delay line.
25:23			NAND_EDO, NAND Async interface EDO position after RE rising edge. [not for SD_eMMC]
22			Sd_intf3, Using SD interface 3
21:18			Ds_sht_exp, 0: DS shift setting never expires, always using the DS_sht_m as shift length. None-zero: 2 <sup>ds_sht_exp</sup> after 2 <sup>ds_sht_exp</sup> "ms", the setting expired The internal FSM will automatically change the Ds shift setting.
17:12			Ds_sht_m, Shift DS by number of 50ps delay cells. If using auto FSM mode, it is the initial value.
11			Eyetest_on, 1: Turn on eye test After eyetest_done, set this bit to 0 to reset eyetest internal registers.
10:6			Eyetest_exp, Repeat the eye test for 2 <sup>eyetest_exp</sup> times, Or the test results together, report the final results.
5			Clktest_on_m, Manual turn on clock test
4:0			Clktest_exp, Repeat the clock test for 2 <sup>clktest_exp</sup> times. Add the clock length together, report the sum.

Table 12-262 SD\_EMMC\_START 0x40

Bit(s)	R/W	Default	Description
31:2	R/W	0	Desc_addr[31:2]: Descriptor address, the last 2 Bits are 0, SRAM: 4 bytes aligned, the valid address range is from 0x200~0x3ff DDR: 8 bytes aligned the valid address is anywhere in DDR, the length of chain is unlimited. Desc_addr = ADDR>>2.
1	R/W	0	Desc_busy: Start/Stop 1: Start command chain execution process. 0: Stop Write 1 to this register starts execution. Write 0 to this register stops execution.
0	R/W	0	Desc_int: SRAM/DDR 1: Read descriptor from internal SRAM, limited to 32 descriptors. 0: Read descriptor from external DDR

Table 12-263 SD\_EMMC\_CFG 0x44

Bit(s)	R/W	Default	Description
31:28	R/W	0	Cfg_ip_txd_adj: Data 1 interrupt, when in TXD mode, the data 1 irq is a input signal, the round trip delay is uncertain factor, change this cfg to compensate the delay.
27	R/W	0	Cfg_err_abort: 1: abort current read/write and issue IRQ 0: continue on current read/write blocks.
26	R/W	0	Cfg_irq_ds: 1: Use DS pin as SDIO IRQ input, 0: Use DAT1 pin as SDIO IRQ input.
25	R/W	0	Cfg_txd_retry: When TXD CRC error, host sends the block again. The total number of retries of one descriptor is limited to 15, after 15 retries, the TXD_err is set to high.

Bit(s)	R/W	Default	Description
24	R/W	0	Cfg_txd_add_err: TXD add error test. Test feature, should not be used in normal condition. It will inverted the first CRC Bits of the 3rd block. Block index starts from 0, 1, 2, ...
23	R/W	0	Cfg_auto_clk: SD/eMMC Clock Control 1: when BUS is idle and no descriptor is available, automatically turn off clock, to save power. 0: whenever core clock is on the SD/eMMC clock is ON, it is still on/off during read data from SD/eMMC.
22	R/W	0	Cfg_stop_clk: SD/eMMC Clock Control 1: no clock for external SD/eMMC, used in voltage switch. 0: normal clock, the clock is automatically on/off during reading mode to back off reading in case of DDR slow response.
21	R/W	0	Cfg_cmd_low: Hold CMD as output Low eMMC boot mode.
20	R/W	0	Reserved
19	R/W	0	Cfg_ignore_owner: Use this descriptor even if its owner bit is "0".
18	R/W	0	Cfg_sdclk_always_on: 1: SD/eMMC clock is always ON 0: SD/eMMC clock is controlled by host. WARNING: Set SD/eMMC clock to always ON, host may lose data when DDR is slow.
17	R/W	0	Cfg_blk_gap_ip: 1: Enable SDIO data block gap interrupt period 0: Disabled.
16	R/W	0	Cfg_out_fall: DDR mode only The command and TXD start from rising edge. Set 1 to start from falling edge.
15:12	R/W	0	Cfg_rc_cc: Wait response-command, command-command gap before next command, 2cfg_rc_cc core clock cycles.
11:8	R/W	0	Cfg_resp_timeout: Wait response till 2cfg_resp_timeout core clock cycles. Maximum 32768 core cycles.
7:4	R/W	0	Cfg_bl_len: Block length 2cfg_bl_len, because internal buffer size is limited to 512 bytes, the cfg_bl_len <=9.
3	R/W	0	Cfg_dc_ugt: 1: DDR access urgent 0: DDR access normal
2	R/W	0	Cfg_ddr: 1: DDR mode 0: SDR mode
1:0	R/W	0	Cfg_bus_width: 0: 1 bit 1: 4 Bits 2: 8 Bits 3: 2 Bits (not supported)

Table 12-264 SD\_EMMC\_STATUS 0x48

Bit(s)	R/W	Default	Description
31	R		Core_busy: 1: core is busy, desc_busy or sd_emmc_irq or bus_fsm is not idle. 0: core is idle.
30	R		Desc_busy: 1: Desc input process is busy, more descriptors in chain. 0: no more descriptor in chain or desc_err.
29:26	R		Bus_fsm: BUS fsm
25	R		DS: Input data strobe
24	R		CMD_i: Input response signal
23:16	R		DAT_i: Input data signals

Bit(s)	R/W	Default	Description
15	R/W		IRQ_sdio: SDIO device uses DAT[1] to request IRQ
14	R/W		Resp_status: When resp_num is set to 1, the resp_addr is the response status IRQ enable Bits, if there is an error.
13	R/W		End_of_Chain: End of Chain IRQ, Normal IRQ
12	R/W		Desc_timeout: Descriptor execution time over time limit. The timeout limit is set by descriptor itself. Consider the multiple block read/write, set the proper timeout limits.
11	R/W		Resp_timeout: No response received before time limit. The timeout limit is set by cfg_resp_timeout.
10	R/W		Resp_err: Response CRC error
9	R/W		Desc_err: SD/eMMC controller doesn't own descriptor. The owner bit is "0", set cfg_ignore_owner to ignore this error.
8	R/W		Txd_err: TX data CRC error, For multiple block write, any one of blocks CRC error.
7:0	R/W		Rxd_err: RX data CRC error per wire, for multiple block read, the CRC errors are Ored together.

Table 12-265 SD\_EMMC\_IRQ\_EN 0x4c

Bit(s)	R/W	Default	Description
31:18			unused
17			Cfg_cmd_setup, 1: improve CMD setup time by half SD_CLK cycle. 0: CMD is two cycle aligned with DATA.
16	R/W	0	Cfg_secure: Data read/write with crypto DES
15	R/W	0	en_IRQ_sdio: Enable sdio interrupt.
14	R/W	0	en_resp_status: Response status error.
13	R/W	0	en_End_of_Chain: End of Chain IRQ
12	R/W	0	en_Desc_timeout: Descriptor execution time over time limit.
11	R/W	0	en_Resp_timeout: No response received before time limit.
10	R/W	0	en_Resp_err: Response CRC error
9	R/W	0	en_Desc_err: SD/eMMC controller doesn't own descriptor.
8	R/W	0	En_txd_err: TX data CRC error
7:0	R/W	0	en_Rxd_err: RX data CRC error per wire.

Table 12-266 Descriptor\_REG0 0x50

Bit(s)	R/W	Default	Description
31:0	R/W		SD_EMMC_CMD_CFG APB read wait Same as descriptor first word, resp_num = 1, response saved back into descriptor only. Read from this APB will hold APB bus

**Table 12-267 Descriptor\_REG1 0x54**

Bit(s)	R/W	Default	Description
31:0	R/W		SD_EMMC_CMD_ARG APB write start Same as descriptor second word. Write to this APB address starts execution. If the current desc is busy, it will be executed after current descriptor is done.

**Table 12-268 Descriptor\_REG2 0x58**

Bit(s)	R/W	Default	Description
31:0	R/W		SD_EMMC_CMD_DAT: Same as descriptor third word, 32 Bits data.

**Table 12-269 Descriptor\_REG3 0x5c**

Bit(s)	R/W	Default	Description
31:0	R/W		SD_EMMC_CMD_RSP: Write: response status IRQ enable Bits. Read: Response Bit 31:0

**Table 12-270 Descriptor\_REG4 0x60**

Bit(s)	R/W	Default	Description
31:0	R		SD_EMMC_CMD_RSP1: Response bit 63:32

**Table 12-271 Descriptor\_REG5 0x64**

Bit(s)	R/W	Default	Description
31:0	R		SD_EMMC_CMD_RSP2: Response bit 95:64

**Table 12-272 Descriptor\_REG6 0x68**

Bit(s)	R/W	Default	Description
31:0	R		SD_EMMC_CMD_RSP3: Response bit 127:96

**Table 12-273 Descriptor\_REG7 0x6c**

Bit(s)	R/W	Default	Description
31:0			Reserved

**Table 12-274 Current\_Next\_Descriptor\_REG0 0x70**

Bit(s)	R/W	Default	Description
31:0	R		SD_EMMC_CURR_CFG: Current descriptor under execution.

**Table 12-275 Current\_Next\_Descriptor\_REG1 0x74**

Bit(s)	R/W	Default	Description
31:0	R		SD_EMMC_CURR_ARG

**Table 12-276 Current\_Next\_Descriptor\_REG2 0x78**

Bit(s)	R/W	Default	Description
31:0	R		SD_EMMC_CURR_DAT

**Table 12-277 Current\_Next\_Descriptor\_REG3 0x7c**

Bit(s)	R/W	Default	Description
31:0	R		SD_EMMC_CURR_RSP

**Table 12-278 Current\_Next\_Descriptor\_REG4 0x80**

Bit(s)	R/W	Default	Description
31:0	R		SD_EMMC_NEXT_CFG: Next descriptor waiting for execution, already read out from SRAM or DDR, can't be changed.

**Table 12-279 Current\_Next\_Descriptor\_REG5 0x84**

Bit(s)	R/W	Default	Description
31:0	R		SD_EMMC_NEXT_ARG

**Table 12-280 Current\_Next\_Descriptor\_REG6 0x88**

Bit(s)	R/W	Default	Description
31:0	R		SD_EMMC_NEXT_DAT

**Table 12-281 Current\_Next\_Descriptor\_REG7 0x8c**

Bit(s)	R/W	Default	Description
31:0	R		SD_EMMC_NEXT_RSP

**Table 12-282 SD\_EMMC\_RXD 0x90**

Bit(s)	R/W	Default	Description
31:25	R		Unused
24:16	R		Data_blk: Rxd Blocks received from BUS Txd blocks received from DDR.
15:10			unused
9:0	R		Data_cnt: Rxd words received from BUS. Txd words received from DDR.



Table 12-283 SD\_EMMC\_TXD 0x94

Bit(s)	R/W	Default	Description
31:25			Unused
24:16	R		Txd_blk: Txd BUS block counter
15			unused
14:0	R		Txd_cnt: Txd BUS cycle counter

## 12.4 Serial Peripheral Interface Communication

### Controller

#### 12.4.1 Overview

SPI Communication Controller is designed for connecting general SPI protocol compatible module. This controller allows rapid data communication with less software interrupts than conventional serial communications.

#### 12.4.2 Features

- Full-duplex synchronous serial interface
- Master/Slave configurable
- Four chip selects to support multiple peripherals
- Transfer continuation function allows unlimited length data transfers
- 64-bit wide by 16-entry FIFO for both transmit and receive data
- Polarity and phase of the Chip Select (SS) and SPI Clock (SCLK) are configurable
- Both PIO(Programming In/Out interface) and DMA(Direct Memory Access interface) supported

#### 12.4.3 Function

The following are two SPICC modes of operation:

- **Master Mode**—When the SPICC module is configured as a master, it uses a serial link to transfer data between the SPICC and an external device. A chip-enable signal and a clock signal are used to transfer data between these two devices. If the external device is a transmit-only device, the SPICC master's output port can be ignored and used for other purposes. To use the internal TXFIFO and RXFIFO, two auxiliary output signals, SS and SPI\_RDY, are used for data transfer rate control. The user can also program the sample period control register to a fixed data transfer rate.
- **Slave Mode**—When the SPICC module is configured as a slave, the user can configure the SPICC Control register to match the external SPI master's timing. In this configuration, SS becomes an input signal, and is used to control data transfers through the Shift register, as well as to load/store the data FIFO.

There are 5 sub-modules in spi communication controller, i.e. spicc\_reg, spicc\_dmaif, spicc\_txfifo, spicc\_rxfifo, and spicc\_main. Transmitting and receiving are using different channel, that means they have different buffer.

Figure 12-2 SPICC

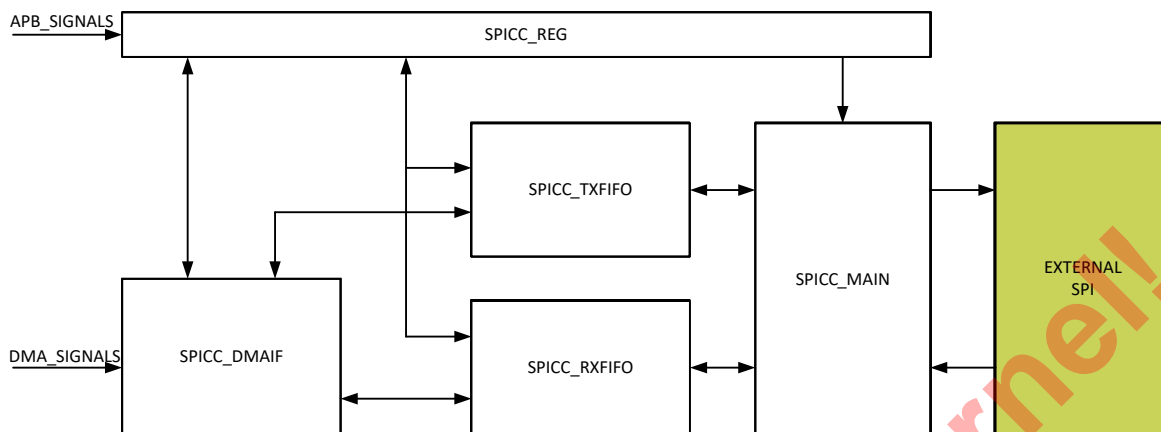

T02FC29

**Note**

- spicc\_reg is driven by host cpu, and spicc\_reg is responsible for configuring other modules.
- spicc\_dmaif is responsible for dealing with DMA operators.
- spicc\_txfifo contains a transmission FIFO.
- spicc\_rxfifo contains a receiving FIFO.
- spicc\_main is responsible for main control of basic spi operation.

Here are SPI External Signals:

Table 12-284 SPI External Signals

Signal Name	I/O	Description
spicc_sclk	IO	SCLK, SPI Clock
spicc_miso	IO	MISO, Master Input Slave Output
spicc_mosi	IO	MOSI, Master Output Slave In
spicc_ss[3:0]	IO	SS, SPI chip Select, Supports up to 4 slaves.

And here is SPI Generic Timing:

Figure 12-3 SPI Generic Timing

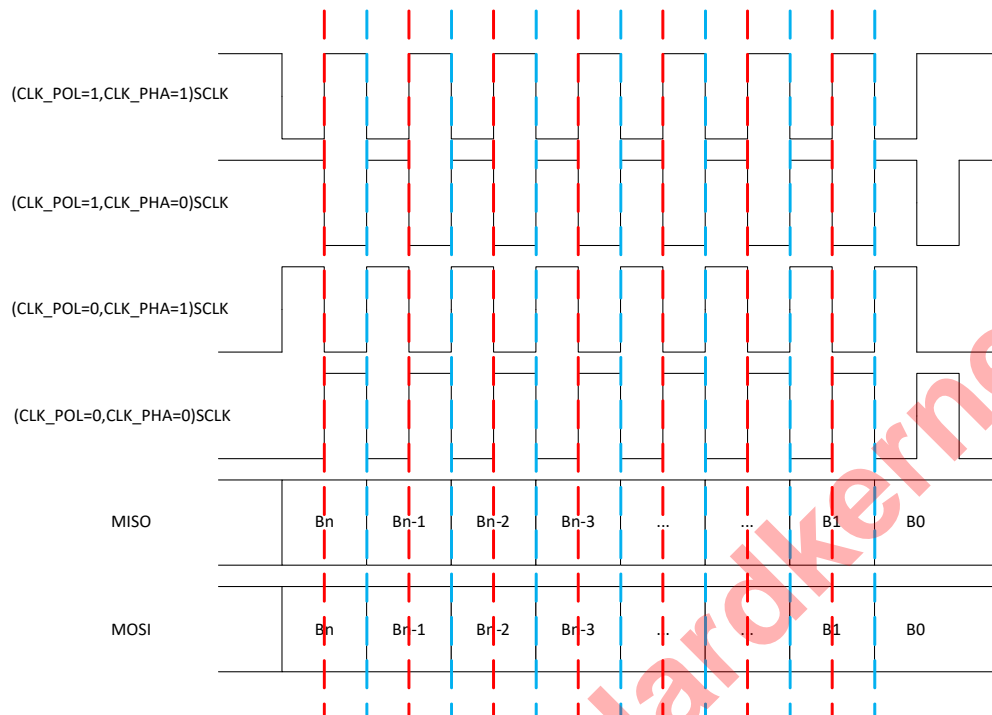

T02TM07

### 12.4.4 Register Description

Table 12-285 RXDATA 0xffd13000

Bit(s)	R/W	Default	Description
31:0	R	0	Rx Data

**Note**

When PIO mode, programmer can get data from this register.

Table 12-286 TXDATA 0xffd13004

Bit(s)	R/W	Default	Description
31:0	W	0	Tx Data

**Note**

When PIO mode, programmer need send data to this register.

Table 12-287 CONREG 0xffd13008

Bit(s)	R/W	Default	Description
31:19	RW	0	[13]burst_length ([5:0]bit number of one word/package, [12:6]burst length-1)
18:16	RW	0	[3]data_rate (sclk will be divided by system clock with equation: $2^{(data\_rate+2)}$ , Example: if system clock = 128MHz and data_rate=2, sclk's frequency equals 8MHz)
15:14			Reserved
13:12	RW	0	[2]chip_select (00:select ss_0, 01:select ss_1, 10:select ss_2, 11:select ss_3,)
11:10			Reserved
9:8	RW	0	[2]drctl (0:ignore RDY input, 1:Data ready using pin rdy_i's falling edge, 2:Data ready using pin rdy_i's low level, 3:reserved)
7	RW	0	[1]sspol (0:SS polarity Low active,1:High active)
6	RW	0	[1]ssctl (see details in Note1)
5	RW	0	[1]pha (clock/data phase control, see section 2.2)
4	RW	0	[1]pol (clock polarity control, see section 2.2)
3	RW	0	[1]smc (start mode control, see Note2)
2	RW	0	[1]xch(exchange bit, ATTN:will automatically cleared when burst finished, see Note3)
1	RW	0	[1]mode (0:slave,1:master)
0	RW	0	[1]en (0:spicc disable,1:enable)

**Note**

- In one burst of master mode, if ssctl ==1, ss will output 1 between each spi transition. And if ssctl ==0, ss will output 0.
- Smc is for start mode control. If smc ==0, burst will start when xch is set to 1'b1; if smc==1, burst will start when txfifo is not empty.
- Setting xch will issue a burst when smc==0, and This bit will be self-cleared after burst is finished.

Table 12-288 INTREG 0xffd1300c

Bit(s)	R/W	Default	Description
31:8			Reserved
7	RW	0	[1]tcen(transfer completed interrupt enable)
6	RW	0	Reserved
5	RW	0	[1]rfen(rxfifo full interrupt enable)

Bit(s)	R/W	Default	Description
4	RW	0	Reserved
3	RW	0	[ 1]rren(rxfifo ready interrupt enable)
2	RW	0	[ 1]tfen(txfifo full interrupt enable)
1	RW	0	Reserved
0	RW	0	[ 1]teen(txfifo empty interrupt enable)

**Note**

Interrupt Status presents in STATREG.

**Table 12-289 DMAREG 0xffd13010**

Bit(s)	R/W	Default	Description
31:26	RW	0	[ 6]DMA Burst Number
25:20	RW	0	[ 6]DMA Thread ID
19	RW	0	[ 1]DMA Urgent
18:15	RW	0x7	[ 4]Number in one Write request burst(0:1,1:2...)
14:11	RW	0x7	[ 4]Number in one Read request burst(0:1,1:2...)
10:6	RW	0x8	[ 5]RxFIFO threshold(RxFIFO's count>=thres, will request write)
5:1	RW	0	[ 5]TxFIFO threshold(TxFIFO's count<=thres, will request read)
0	RW	0	[ 1]DMA Enable

**Table 12-290 STATREG 0xffd13014**

Bits	R/W	Defaults	Description
31:8			Reserved
7	RW	0	[ 1]tc(transfer completed, w1c, see Note1)
6	R	0	Reserved
5	R	0	[ 1]rf(rxfifo full)
4	R	0	Reserved
3	R	0	[ 1]rr(rxfifo ready)
2	R	0	[ 1]tf(txfifo full)
1	R	0	Reserved
0	R	0	[ 1]te(txfifo empty)

**Note**

Tc is the status bit which indicates a burst transfer is completed. And a burst transfer should be started by writing xch 1'b1. This bit supports w1c(Write 1 clear).

**Table 12-291 PERIODREG 0xffd13018**

Bit(s)	R/W	Default	Description
31:15			Reserved
14:0	RW	0	[15]period(wait cycles, see Note1)

**Note**

Programmer can add wait cycles through this register if transmission rate need to be controlled.

**Table 12-292 TESTREG 0xffd1301c**

Bit(s)	R/W	Default	Description
31:23	RW	0	Reserved
23:22	RW	0	[ 2]ffirst(fifo soft reset)
21:16	RW	0x15	[ 6]dlyctl(delay control)
15	RW	0	[ 1]swap(data swap for reading rxfifo)
14	RW	0	[ 1]lbc(loop back control)
12:10	R	0	[ 3]smstatus(internal state machine status)
9:5	R	0	[ 5]rxcnt(internal RxFIFO counter)
4:0	R	0	[ 5]txcnt(internal TxFIFO counter)

**Note**

Programmer can only use the TESTREG[9:0], rxcnt(internal RxFIFO counter) and txcnt(internal TxFIFO counter) , and other Bits just for test.

**Table 12-293 DRADDR 0xffd13020**

Bit(s)	R/W	Default	Description
31:0	RW	0	Read Address of DMA

**Table 12-294 DWADDR 0xffd13024**

Bit(s)	R/W	Default	Description
31:0	RW	0	Write Address of DMA

**Table 12-295 LD\_CNTL0 0xffd13028**

Bits	R/W	Defaults	Description
31:9	RW	0	Reserved
8	RW	0	dma raddr/waddr load by dma_enable signal
7	RW	0	dma waddr load by vsync irq
6	RW	0	dma raddr load by vsync irq
5	RW	0	dma write counter enable

Bits	R/W	Defaults	Description
4	RW	0	dma read counter enable
3	RW	0	xch enable set by vsync irq
2	RW	0	dma enable set by vsync irq
1	RW	0	Reserved
0	RW	0	Vsync irq source select

Table 12-296 LD\_CNTL1 0xffd1302c

Bits	R/W	Defaults	Description
31:16	RW	0	dma write counter
15:0	RW	0	dma read counter

Table 12-297 LD\_RADDR 0xffd13030

Bits	R/W	Defaults	Description
31:0	RW	0	shadow dma read address for load

Table 12-298 LD\_WADDR 0xffd13034

Bits	R/W	Defaults	Description
31:0	RW	0	shadow dma write address for load

Table 12-299 ENHANCE\_CNTL 0xffd13038

Bits	R/W	Defaults	Description
31:30	R	0	Reserved
29	R/W	0	main clock always on
28	R/W	0	clk-cs delay enable
27	R/W	0	cs_oen enhance enable
26	R/W	0	clk_oen enhance enable
25	R/W	0	mosi_oen enhance enable
24	R/W	0	spi clk select 0: controlled by data_rate in CONREG 1: controlled by enhance_clk_div in ENHANCE_CNTL
23:16	R/W	0	enhance_clk_div
15:0	R/W	0	clk-cs delay value

Table 12-300 ENHANCE\_CNTL1 0xffd1303c

Bits	R/W	Defaults	Description
31:29	R/W	0	enhance_fclk_mosi_oen_dlyctl: mosi_oen delay control in fclk
28	R/W	0	enhance_fclk_mosi_oen_dlyctl_en: enable dlyctl
27:25	R/W	0	enhance_fclk_mosi_o_dlyctl: mosi_o delay control in fclk
24	R/W	0	enhance_fclk_mosi_o_dlyctl_en: enable dlyctl
23:21	R/W	0	enhance_fclk_miso_i_dlyctl: miso_i delay control in fclk
20	R/W	0	enhance_fclk_miso_i_dlyctl_en: enable dlyctl
19:17	R/W	0	enhance_fclk_mosi_i_dlyctl: mosi_i delay control in fclk
16	R/W	0	enhance_fclk_mosi_i_dlyctl_en: enable dlyctl
15	R/W	0	enhance_fclk_en: fclk gate enable
14	R/W	0	enhance_mosi_i_capture_en: enable, 1=select enhance capture function for mosi_i (slave mode)
9:1	R/W	0	enhance_clk_tcnt: adjust capturing timing for miso_i data (master mode). when clk_cnt=enhance_clk_tcnt, capture input data. the value of enhance_clk_tcnt must be less than the most value of clk_cnt. sclk will be divided by system clock with clk_cnt.
0	R/W	0	enhance_miso_i_capture_en: enable, 1=select enhance capture function for miso_i (master mode)

Table 12-301 ENHANCE\_CNTL2 0xffd13040

Bits	R/W	Defaults	Description
31	R/W	0	clk_cs_tt delay enable
30:16	R/W	0	clk_cs_tt delay value
15	R/W	0	clk_cs_ti delay enable
14:0	R/W	0	clk_cs_ti delay value

SPICC1: See the registers for SPICC0

## 12.5 Serial Peripheral Interface Flash Controller

### 12.5.1 Overview

SPI Flash Controller is designed for connecting varied SPI Flash memory.

### 12.5.2 Features

- Support three operation modes, NOR Flash mode, Master mode, and Slave mode.
- Support read/write buffer up to 64bytes.
- Support no clock toggling during DUMMY state.
- Support hold by an external pin during a transition.
- AHB read support byte and halfword.



- Support bit-number rather than byte-number for each stage.
- Support 2/4 wire writing like fast reading
- Support both rising-edge and falling-edge for SPI slave sampling and SPI master sampling.
- Support 1 wire for SPI\_D and SPI\_Q.
- Support SPI\_CK setup and hold time by cycles
- Support 8 bit clock divider, so SPI\_CK can be low as 1/256 HCLK
- Support byte-order in a word
- Support no command state, so the command is sent/received in address state by 2/4 wires.
- Support both data input and data output in a transition. SPI\_DOUT->(SPI\_DUMMY)->SPI\_DIN

### 12.5.3 Register Description

#### Note

If the bit2 “Backward Compatible” in “SPI User Register” is 1, the registers and functions of this SPI controller are as same as Apollo SPI controller.

To use SPI Flash commands, please set the bit2 “Backward Compatible” in “SPI User Register” as “1”.

**Table 12-302 SPI FLASH Command register 0xffd14000**

Bit(s)	R/W	Default	Description
31	R/W	0	READ command. 1 = read. When it becomes 0, the read command is finished. The READ command could be (0xEB, 0x6B, 0xBB, 0x3B, 0x0B, 0x03). By default is 0x0B. One read command will read erilog 32x8bits data. And saved in data cache.
30	R/W	0	WREN command. (0x06)
29	R/W	0	WRDI command. ( 0x04).
28	R/W	0	RDID command. (0x9f).
27	R/W	0	RDSR command. (0x05).
26	R/W	0	WRSR command. (0x01).
25	R/W	0	Page program command. (0xAD or 0x02).
24	R/W	0	SE command (0x20).
23	R/W	0	BE command ( 0xD8).
22	R/W	0	CE command.(0xC7).
21	R/W	0	Deep Power Down command(0xB9).
20	R/W	0	RES command. (0xAB).
19	R/W	0	HPM command.(0xA3). (Just For winbond SPI flash).
18	R/W	0	USER defined command.
17:0	R/W	0	Reserved for future.

If the bit2 “Backward Compatible” in “SPI User Register” is 1, the bit15:0 of this registers are defined as same as Apollo SPI controller.

Bit(s)	R/W	Default	Description
15	R/W	0	USER command address bit. 1 = user command includes address. 0 = no address.
14	R/W	0	USER command dummy bit. 1= user command includes Dummy bytes.
13	R/W	0	USER command DIN bit. 1 = use command includes data in. 0 = no data in.
12	R/W	0	USER command DO bit. 1 -= use command includes data output. 0 = no data output. Only DIN or DO support for one User command. Not both.
11:10	R/W	0	User command dummy byte number. How many dummy bytes for user command.
9:8	R/W	0	Reserved for future.
7:0	R/W	0	command value for User command bit[7:0].

**Table 12-303 SPI address register 0xffd14004**

Bit(s)	R/W	Default	Description
31:0	R/W	0	The address[31:0] of the user command

If the bit2 “Backward Compatible” in “SPI User Register” is 1, the bit15:0 of this registers are defined as same as Apollo SPI controller.

31:30	R/W	0	Reserved.
29:24	R/W	0	DIN/DO data bytes number.
23:0	R/W	0	24 bits address.

**Table 12-304 SPI control register 0xffd14008**

Bit(s)	R/W	Default	Description
31:27	R/W	0	Reserved.
26	R/W	0	Write bit order. 1 = 0, 1, 2, 3, 4, 5, 6, 7. 0 = 7, 6, 5, 4, 3, 2, 1, 0.
25	R/W	0	Read bit order. . 1 = 0, 1, 2, 3, 4, 5, 6, 7. 0 = 7, 6, 5, 4, 3, 2, 1, 0.
24	R/W	0	Fast read QIO mode.
23	R/W	0	Fast read DIO mode.
22	R/W	0	Write 2 bytes status mode. For some of winbond SPI flash, the status register is 16bits.
21	R/W	1	SPI flash WP pin value if use SPI flash WP pin as write protection.
20	R/W	0	Fast read QOUT mode.
19	R/W	1	1 = SPI share pins with SDRAM. 0 = doesn't share.
18	R/W	0	SPI hold mode. 1=SPI controller would use SPI hold function. 0 = SPI controller won't use hold function. The SPI flash hold pin can be tie high on the board. Or SPI controller can use hold pin as QIO/QOUT mode.
17	R/W	1	1 = enable AHB request. 0 = disable AHB request when you reconfigure SPI controller or running APB bus commands.

Bit(s)	R/W	Default	Description
16	R/W	0	1 =enable SST SPI Flash aai command. The APB bus PP command will send AAI command.
15	R/W	1	1 = release from Deep Power-Down command is with read electronic signature.
14	R/W	0	Fast read DOUT mode.
13	R/W	1	Fast read mode. AHB bus read requirement and APB bus read command use the command 0x0Bh.
12:0	R/W	0	Reserved for future.

If the bit2 “Backward Compatible” in “SPI User Register” is 1, the bit12:0 of this registers are defined as same as Apollo SPI controller.

Bit(s)	R/W	Default	Description
12	R/W	1	1=SPI clock frequency is same as system clock. 0 = SPI clock frequency will use clock divider.
11:8	R/W	0	Clock counter for clock divider.
7:4	R/W	0	Clock high counter.
3:0	R/W	0	Clock low counter. If the SPI clock frequency = sys_clock_frequency / n. Then the clock divider counter = n - 1; the clock high counter = n / 2 - 1; the clock low counter = n- 1; For example, if you want to SPI clock erilog is divided by 2 of the system clock. The clock divider counter = 1, clock high counter = 0, clock low counter = 1. For SPI clock frequency = system clock / 4. The clock divider counter = 3, clock high counter = 1, clock low counter = 3.

**Table 12-305 SPI control register 1 0xffd1400c**

Bit(s)	R/W	Default	Description
31:28	R/W	5	SPI Clock cycles for SPI flash timing requirement tCSH.
27:16	R/W	0xfff	SPI Clock cycles for SPI flash timing requirement tRES.
15:0	R/W	0x0120	System clock cycles for SPI bus timer. In SPI share bus and SPI hold function mode. SPI bus timer used , if SPI use the bus for a limit time, SPI controller will diassert SPI hold pin to halt the SPI Flash, and give the bus control to SDRAM.

**Table 12-306 SPI status register**

Bit(s)	R/W	Default	Description
31:24	R/W	0	Reserved.
23:16	R/W	0	For winbond SPI flash, this 8 bits used for DIOMode M7~M0,
15:0	R/W	0	SPI status register value. WRSR command will write this value to SPI flash status. RDSR or RES command will save the read result to this register.

When SPI controller in the slave mode, this register are the status for the SPI master to read out.

Bit(s)	R/W	Default	Description
31:0	R/W	0	In SPI Slave mode, the read status of the user command

Table 12-307 SPI control register 2 0xffd14014

Bit(s)	R/W	Default	Description
31:28	R/W	0	Delay cycle number of SPI_CS input in SPI slave mode or SPI_CS output in SPI master mode 0= not delay, 1 = delayed by 1 cycle of system clock, 2 = delayed by 2 cycles of system clock , ...
27:26	R/W	0	delay mode of SPI_CS input in SPI slave mode or SPI_CS output in SPI master mode 0= not latched by the edges of SPI_CK 1= latched by the falling edges of SPI_CK 2 = latched by the rising edges of SPI_CK
25:23	R/W	0	Delay cycle number of SPI Data from SPI Master to SPI Slave In SPI master mode, it is for data outputs; in SPI slave mode, it is for data inputs. 0= not delay, 1 = delayed by 1 cycle of system clock, 2 = delayed by 2 cycles of system clock , ...
22:21	R/W	0	Delay mode of SPI Data from SPI Master to SPI Slave In SPI master mode, it is for data outputs; in SPI slave mode, it is for data inputs. 0= not latched by the edges of SPI_CK 1= latched by the falling edges of SPI_CK 2 = latched by the rising edges of SPI_CK
20:18	R/W	0	Delay cycle number of SPI Data from SPI Slave to SPI Master. In SPI master mode, it is for data inputs; in SPI slave mode, it is for data outputs. 0= not delay, 1 = delayed by 1 cycle of system clock, 2 = delayed by 2 cycles of system clock , ...
17:16	R/W	0	Delay mode of SPI Data from SPI Slave to SPI Master. In SPI master mode, it is for data inputs; in SPI slave mode, it is for data outputs. 0= not latched by the edges of SPI_CK 1= latched by the falling edges of SPI_CK 2 = latched by the rising edges of SPI_CK
15:12	R/W	0	In SPI master mode, SPI_CK rising edge mode 4'b1000 = later by 1/4 cycle of SPI_CK 4'b1001 = later by 1/8 cycle of SPI_CK 4'b1010 = later by 1/16 cycle of SPI_CK 4'b1011 = later by 1/32 cycle of SPI_CK 4'b1100 = earlier by 1/4 cycle of SPI_CK 4'b1101 = earlier by 1/8 cycle of SPI_CK 4'b1110 = earlier by 1/16 cycle of SPI_CK 4'b1111 = earlier by 1/32 cycle of SPI_CK Others = Normal
11:8	R/W	0	In SPI master mode, SPI_CK falling edge mode 4'b1000 = later by 1/4 cycle of SPI_CK 4'b1001 = later by 1/8 cycle of SPI_CK 4'b1010 = later by 1/16 cycle of SPI_CK 4'b1011 = later by 1/32 cycle of SPI_CK 4'b1100 = earlier by 1/4 cycle of SPI_CK 4'b1101 = earlier by 1/8 cycle of SPI_CK 4'b1110 = earlier by 1/16 cycle of SPI_CK 4'b1111 = earlier by 1/32 cycle of SPI_CK Others = Normal
7:4	R/W	1	In master mode, SPI clock cycles for SPI hold timing.
3:0	R/W	1	In master mode, SPI clock cycles for SPI setup timing. SPI setup time and SPI hold time is used to configure how soon the controller can enable spi_cs_n after the controller get the bus and how long the controller still keep the bus after the spi_cs_n become to be high.

**Table 12-308 SPI Clock register 0xffd14018**

Bit(s)	R/W	Default	Description
31	R/W	1	1=SPI clock frequency is same as system clock. 0 = SPI clock frequency will use clock divider.
30:18	R/W	0	Clock counter for Pre-scale divider: 0= not pre-scale divider, 1= pre-scale divided by 2, 2= pre-scale divided by 3, .....
17:12	R/W	0	Clock counter for clock divider.
11:6	R/W	0	Clock high counter in SPI master mode. In SPI slave mode, it is for the delay counter for the rising edges of spi_ck_i
5:0	R/W	0	Clock low counter, in SPI master mode. In SPI slave mode, it is for the delay counter for the falling edges of spi_ck_i If the SPI clock frequency = sys_clock_frequency / n. Then the clock divider counter = n - 1; the clock high counter = n / 2 - 1; the clock low counter = n - 1; For example, if you want to SPI clock erilog is divided by 2 of the system clock. The clock divider counter = 1, clock high counter = 0, clock low counter = 1. For SPI clock frequency = system clock / 4. The clock divider counter = 3, clock high counter = 1, clock low counter = 3.

**Table 12-309 SPI User register 0xffd1401c**

Bit(s)	R/W	Default	Description
31	R/W	1	USER command COMMAND bit. 1 = user command includes command. 0 = no command. If some SPI slaves may support 2/4 IO at the first cycle, clear this bit.
30	R/W	0	USER command ADDRESS bit. 1 = user command includes address. 0 = no address.
29	R/W	0	USER command DUMMY bit. 1= user command includes Dummy bytes.
28	R/W	0	USER command DIN bit. 1 = user command includes data in. 0 = no data in.
27	R/W	0	USER command DO bit. 1 = user command includes data output. 0 = no data output. If both DIN and DO are valid, SPI master is firstly in data output state and then in data input state. If all of DUMMY, DO and DIN are valid, SPI master is firstly in data output state and then in dummy state, finally in data input state.
26	R/W	0	USER command dummy idle bit. 1= no SPI clock toggling in dummy state. 0= normal
25	R/W	0	USER command highpart bit for SPI_DOUT stage. It is for data-output in spi master mode and for data-input in spi slave mode. 1 = only high half part of buffer are used. 0 = low half part or the whole 64bytes are used.
24	R/W	0	USER command highpart bit for SPI_DIN stage. It is for data-input in spi master mode and for data-output in spi slave mode. 1 = only high half part of buffer are used. 0 = low half part or the whole 64bytes are used.
23	R/W	0	User command external hold bit for prep. 1 = in prep state, SPI master controller can be hold by the external pin SPI_HOLD
22	R/W	0	User command external hold bit for command. 1 = in command state, SPI master controller can be hold by the external pin SPI_HOLD
21	R/W	0	User command external hold bit for address. 1 = in address state, SPI master controller can be hold by the external pin SPI_HOLD

Bit(s)	R/W	Default	Description
20	R/W	0	User command external hold bit for dummy. 1 = in dummy state, SPI master controller can be hold by the external pin SPI_HOLD
19	R/W	0	User command external hold bit for data input. 1 = in data input state, SPI master controller can be hold by the external pin SPI_HOLD
18	R/W	0	User command external hold bit for data output. 1 = in data output state, SPI master controller can be hold by the external pin SPI_HOLD
17	R/W	1	User command external hold polarity bit. 1 = high is valid for hold, 0 = low is valid for hold.
16	R/W	0	Single DIO mode: Data output and input apply only 1 wire.
15	R/W	0	Fast write QIO mode.
14	R/W	0	Fast write DIO mode.
13	R/W	0	Fast write QOUT mode.
12	R/W	0	Fast write DOUT mode.
11	R/W	0	Write byte order. 0 = d[7:0], d[15:8], d[23:16], d[31:24]. 1 = d[31:24], d[23:16], d[15:8], d[7:0]
10	R/W	0	Read byte order. . 0 = d[7:0], d[15:8], d[23:16], d[31:24]. 1 = d[31:24], d[23:16], d[15:8], d[7:0]
9:8	R/W	0	AHB endian mode: 0= little-endian; 1= big-endian; 2~3 reserved
7	R/W	0	In SPI master mode, the clock output edge bit: 0 = SPI_CK is inverted, 1 = SPI_CK is not inverted
6	R/W	1	In SPI slave mode, the clock input edge bit: 0 = SPI_CK_I is inverted, 1 = SPI_CK_I is not inverted
5	R/W	0	SPI CS setup bit: 1 = valid in prep state
4	R/W	0	SPI CS hold bit: 1 = valid in done state
3	R/W	0	AHB-read apply the configurations of user-command, such as command value, bit-length,...
2	R/W	1	Backward Compatible: 1 = compatible to Apollo SPI This bit affect the three registers: "SPI Flash Command Register", "SPI Address Register" and "SPI Control Register"
1	R/W	0	AHB-read support 4byte address, when AHB-read apply the configurations of user-command. 1 = 4byte address, 0 = 3byte address
0	R/W	0	In SPI master mode, Enable bit for Data input during SPI_DOUT stage. 1 = enable; 0 = disable This bit shall not be used in 2/4wire or SIO. When this bit is 1, during SPI_DOUT stage, data input are stored into cacheline/ buffer from address 0, i.e., Bit24 is not controlling the start address. The data output can be specified by bit25

Table 12-310 SPI User register 1 0xffd14020

Bit(s)	R/W	Default	Description
31:26	R/W	0	USER command bit number for address state 0 = 1 bit, 1= 2 bits, ...
25:17	R/W	0	USER command bit number for data output state 0 = 1 bit, 1= 2 bits, ...

Bit(s)	R/W	Default	Description
16:8	R/W	0	USER command bit number for data input state 0 = 1 bit, 1= 2 bits, ...
7:0	R/W	0	USER command cycle number for dummy state 0 = 1 cycle, 1= 2 cycles, ...

Table 12-311 SPI User register 2 0xffd14024

Bit(s)	R/W	Default	Description
31:28	R/W	0	USER command bit number for command state 0 = 1 bit, 1= 2 bits, ...
27:16	R/W	0	Reserved
15:0	R/W	0	The command content of the user command

Table 12-312 SPI User register 3 0xffd14028

Bit(s)	R/W	Default	Description
31:0	R/W	0	In SPI Master mode, the address[63:32] of the user command In SPI Slave mode, the write status of the user command

Table 12-313 SPI PIN register 0xffd1402c

Bit(s)	R/W	Default	Description
31	R/W	0	Pin swap when it is in DIN stage and SPI data input are 4wire. This feature is for Ubec Zigbee chips. 1 = swap between {spi_q, spi_d_i} and {spi_hold_i, spi_wp_i} 0 = normal
30	R/W	0	In SPI Master mode, CS keep active after a transition. 1 = enable; 0 = disable
29	R/W	0	Idle edge of SPI_CK 0 = low when it is idle 1 = high when it is idle
28:24	R/W	0	Reserved
23	R/W	0	In the SPI slave mode, spi_cs_i polarity: 1= high voltage is active 0= low voltage is active
22:21	R/W	0	In the SPI slave mode, spi_ck_i and spi_cs_i source pins 0=SPI_CK and SPI_CS pins, respectively 1=SPI_CS2 and SPI_CS1 pins, respectively 2=SPI_HOLD and SPI_WP pins, respectively
20	R/W	0	SPI_CS2 and SPI_CS1 pin function MUX 0= spi_ck and spi_cs in the SPI master mode 1= input pads for spi_ck_i and spi_cs_i, respectively, in the SPI slave mode
19	R/W	0	SPI_CK and SPI_CS pin function MUX 0= spi_ck and spi_cs in the SPI master mode 1= input pads for spi_ck_i and spi_cs_i, respectively, in the SPI slave mode
18:17	R/W	0	SPI_HOLD and SPI_WP pin function MUX 0= normal 1= spi_q and spi_d, respectively 2= spi_cs3 and spi_cs2, respectively

Bit(s)	R/W	Default	Description
			3= input pads for spi_ck_i and spi_cs_i, respectively, in the SPI slave mode
16	R/W	0	SPI_D and SPI_Q switch 1= SPI_D and SPI_Q pin-functions are swapped 0= normal
15:11	R/W	0	In Master mode, these are spi_ck MUX bit[4:0] for spi_cs4 (SPI_HOLD pin), spi_cs3 (SPI_WP pin), spi_cs2, spi_cs1 and spi_cs, respectively 1= this pin is spi_ck, if this pin is not idle 0= this pin is spi_cs, if this pin is not idle
10:6	R/W	0	In Master mode, these are polarity bit[4:0] for spi_cs4 (SPI_HOLD pin), spi_cs3 (SPI_WP pin), spi_cs2, spi_cs1 and spi_cs, respectively 1= high voltage is active 0= low voltage is active
5:0	R/W	0x1E	In Master mode, these are idle bit[5:0] for SPI_CK, for spi_cs4 (SPI_HOLD pin), spi_cs3 (SPI_WP pin), spi_cs2, spi_cs1 and spi_cs, respectively 1= idle, i.e., the spi_ck signal is 0 or the spi_cs is at the inactive level 0= active if SPI controller is working

Table 12-314 SPI Slave register 0xffd14030

Bit(s)	R/W	Default	Description
31	R/W	0	SPI controller SW reset: 1 = reset, 0 = none
30	R/W	0	SPI slave mode: 1 = slave, 0 = master
29	R/W	0	In SPI slave mode, the enable bit for the command of write-buffer-and-read-buffer 0= disable, 1=enable
28	R/W	0	In SPI slave mode, the enable bit for the command of write-status-and-read-status 0= disable, 1=enable
27	R/W	0	SPI slave command define enable 0=Apply the last 3bits of Flash commands and two extra command. 1=Apply the user defined command in SPI Slave register 3
26:4	R/W	0	Reserved
11:10	R/W	0	spi_cs_i recovery mode: 0= and 1= or 2= normal 3= delayed
9:5	R/W	0	Interrupt enable for bit4:0 1= enable, 0=disable
4	R/W	0	A SPI transition is done. (whatever it is in SPI master mode or SPI slave mode)
3	R/W	0	In SPI slave mode, a status write is done
2	R/W	0	In SPI slave mode, a status read is done
1	R/W	0	In SPI slave mode, a buffer write is done
0	R/W	0	In SPI slave mode, a buffer read is done



**Table 12-315 SPI Slave register 1 0xffd14034**

Bit(s)	R/W	Default	Description
31:27	R/W	0	In SPI slave mode, status bit number 0 = 1 bit, 1= 2 bits, ...
26	R/W	0	In SPI slave mode, status fast read/write enable bit: 1 = enable, 0 = disable
25	R/W	0	In SPI slave mode, status read back enable bit: 1 = reading status is written status in SPI User register 3, 0 = reading status is in SPI Status register.
24:16	R/W	0	In SPI slave mode, buffer bit number 0 = 1 bit, 1= 2 bits, ...
15:10	R/W	0	In SPI slave mode, address bit number for reading buffer 0 = 1 bit, 1= 2 bits, ...
9:4	R/W	0	In SPI slave mode, address bit number for writing buffer 0 = 1 bit, 1= 2 bits, ...
3	R/W	0	In SPI slave mode, dummy enable bit for writing status 1=enable, 0=disable
2	R/W	0	In SPI slave mode, Dummy enable bit for reading status 1=enable, 0=disable
1	R/W	0	In SPI slave mode, Dummy enable bit for writing buffer 1=enable, 0=disable
0	R/W	0	In SPI slave mode, Dummy enable bit for reading buffer 1=enable, 0=disable

**Table 12-316 SPI Slave register 2 0xffd14038**

Bit(s)	R/W	Default	Description
31:24	R/W	0	In SPI slave mode, Dummy cycle number for writing buffer 0 = 1 cycle, 1= 2 cycles, ...
23:16	R/W	0	In SPI slave mode, Dummy cycle number for reading buffer 0 = 1 cycle, 1= 2 cycles, ...
15:8	R/W	0	In SPI slave mode, Dummy cycle number for writing status 0 = 1 cycle, 1= 2 cycles, ...
7:0	R/W	0	In SPI slave mode, Dummy cycle number for reading status 0 = 1 cycle, 1= 2 cycles, ...

**Table 12-317 SPI Slave register 3 0xffd1403C**

Bit(s)	R/W	Default	Description
31:24	R/W	0	In SPI slave mode, Command value for writing status, when bit27 "SPI slave command define enable" in SPI Slave register is 1
23:16	R/W	0	In SPI slave mode, Command value for reading status, when bit27 "SPI slave command define enable" in SPI Slave register is 1
15:8	R/W	0	In SPI slave mode, Command value for writing buffer, when bit27 "SPI slave command define enable" in SPI Slave register is 1
7:0	R/W	0	In SPI slave mode, Command value for reading buffer, when bit27 "SPI slave command define enable" in SPI Slave register is 1

**Table 12-318 SPI controller cache 0~7 0xffd14040~0xffd1405c**

Bit(s)	R/W	Default	Description
31:0	R/W	0	Cache line Word 0~7. Cache is used to read data both for AHB or APB read command. Cache is also used for APB page programming etc.

**Table 12-319 SPI controller buffer 8~15 0xffd14060~0xffd1407c**

Bit(s)	R/W	Default	Description
31:0	R/W	0	Buffer Word 8. Buffer is used to read/write data only for APB read/write user commands.

Confidential for Hardkernel!

## 13 I/O Interface

### 13.1 Universal Serial Bus

#### 13.1.1 Overview

The chip integrates one USB XHCI OTG 2.0 ports, one USB3.0 and PCIe 2.0 combo interface up to 5Gbps, supports 2 configurations:

- 1 USB2.0 OTG + 1 USB 2.0 Host + 1 PCIe
- 1 USB2.0 OTG + 1 USB3.0 (No PCIe)

#### 13.1.2 Features

The USB2.0 OTG controller features

- Support for the following speeds: High-Speed (HS, 480-Mbps), Full-Speed (FS, 12-Mbps) and Low-Speed (LS, 1.5-Mbps) modes
- Multiple DMA/non DMA mode access support on the application side
- Supports up to 16 bidirectional endpoints, including control endpoint 0.
- Supports Session Request Protocol (SRP) and Host Negotiation Protocol (HNP)
- Supports up to 16 host channels.
- Supports ACA ID detector, refer to Amlogic USB2.0 OTG ID Detector Specification.pdf for detail

The USB2.0 Host controller features:

- Support for the following speeds: High-Speed (HS, 480-Mbps), Full-Speed (FS, 12-Mbps) and Low-Speed (LS, 1.5-Mbps) modes
- Multiple DMA/non DMA mode access support on the application side
- Supports up to 16 host channels.

The USB2.0 PHY features:

- Support for the following speeds: High-Speed (HS, 480-Mbps), Full-Speed (FS, 12-Mbps) and Low-Speed (LS, 1.5-Mbps) modes

The USB3.0 Host controller features:

- Support for the following speed: Super-Speed, High-Speed, Full-Speed and Low-Speed
- Compliant with the xHCI specification

The USB3.0 SS PHY features:

- 5-Gbps SuperSpeed data transmission rate over 3-m USB 3 cable
- Integrated PHY includes transmitter, receiver, spread spectrum clock (SSC) generation, PLL, digital core, and electrostatic discharge (ESD) protection circuits
- Supports legacy Half-rate mode for power-saving

#### 13.1.3 Register Description

Base address:

PHY 20: 0xff63\_6000.

PHY 21: 0xff63\_A000.

For the following registers, each register's final address= base address + offset \*4.

Table 13-1 reg32\_00 0x00

Bit(s)	R/W	Default	Description
31	R/W	0	PLL_Fine_Tuning_2
30	R/W	1	PLL_Fine_Tuning_1
29	R/W	0	PLL_Fine_Tuning_0
28	R/W	0	PLL_Bypass_Enable
27	R/W	0	PLL_Lock_over_ride
26	R/W	0	pll_clock_divide_5
25	R/W	0	pll_clock_divide_4
24	R/W	0	pll_clock_divide_3
23	R/W	0	pll_clock_divide_2
22	R/W	0	pll_clock_divide_1
21	R/W	0	pll_clock_divide_0
20	R/W	0	refclk_multiplier_5
19	R/W	0	refclk_multiplier_4
18	R/W	1	refclk_multiplier_3
17	R/W	0	refclk_multiplier_2
16	R/W	1	refclk_multiplier_1
15	R/W	0	refclk_multiplier_0
14	R/W	1	reset_FS_LS_Clock_Divider
13	R/W	1	reset_HS_CDR
12	R/W	1	reset_FS_LS_CDR
11:10	R/W	0	reg32_00_11_10_reserved
9	R/W	0	BIAS_Power_Down
8	R/W	0	BGR_Power_Down
7	R/W	0	Calibration_Power_Down
6	R/W	0	HS_Disconnect_Power_Down
5	R/W	0	HS_Squelch_Power_Down
4	R/W	0	FS_LS_RX_Power_Down
3	R/W	0	HS_RX_Power_Down
2	R/W	0	FS_LS_Driver_Power_Down
1	R/W	0	HS_TX_Driver_Power_Down
0	R/W	0	PLL_Power_Down

**Table 13-2 reg32\_01 0x04**

Bit(s)	R/W	Default	Description
31:24	R/W	0	TBD_3
23:16	R/W	0	TBD_2
15:10	R/W	0	TBD_1
9	R/W	0	hs_en_mode
8	R/W	0	spare
7:4	R/W	0	TBD_0
3:2	R/W	0	bypass_en
1:0	R/W	0x3	slew_control

**Table 13-3 reg32\_02 0x08**

Bit(s)	R/W	Default	Description
31	RO	0	Phy_status
30	RO	0	cal_en_flag
29:27	RO	0	reg32_02_29_27_reserved
26	RO	0	HS_Disconnect_Status
25	RO	0	HS_Squelch_Status
24	RO	0	PRBS_Sync_Out
23:16	RO	0	Calibration_code_Value_23_16
15:8	RO	0	Calibration_code_Value_15_8
7:0	RO	0	Calibration_code_Value_7_0

**Table 13-4 reg32\_03 0x0c**

Bit(s)	R/W	Default	Description
31:24	R/W	0	TBD_7
23:16	R/W	0	TBD_6
15:8	R/W	0	TBD_5
7:4	R/W	0x2	TBD_4
4:2	R/W	0x1	hsdic_ref
2:0	R/W	0	squelch_ref

**Table 13-5 reg32\_04 0x10**

Bit(s)	R/W	Default	Description
31:30	R/W	0	i_c2l_bias_trim_3_2
29:28	R/W	0	i_c2l_bias_trim_1_0

Bit(s)	R/W	Default	Description
27	R/W	0	TEST_Bypass_mode_enable
26	RO	0	i_c2l_cal_done
25	R/W	0	i_c2l_cal_reset_n
24	R/W	0	i_c2l_cal_en
23:16	R/W	0	Calibration_code_Value_23_16
15:8	R/W	0	Calibration_code_Value_15_8
7:0	R/W	0	Calibration_code_Value_7_0

Table 13-6 reg32\_05 0x14

Bit(s)	R/W	Default	Description
31:24	R/W	0	i_c2l_obs_7_0
23:22	R/W	0	reg32_05_23_22_reserved
21:20	R/W	0	i_c2l_pll_perfcfg_21_20
19	R/W	0x1	i_c2l_pll_perfcfg_19
18:16	R/W	0	i_c2l_pll_perfcfg_18_16
15:12	R/W	0	i_c2l_pll_perfcfg_15_12
11:10	R/W	0	i_c2l_pll_perfcfg_11_10
9	R/W	0x1	i_c2l_pll_perfcfg_9
8	R/W	0x1	i_c2l_pll_perfcfg_8
7:4	R/W	0x7	i_c2l_pll_perfcfg_7_4
3:2	R/W	0x3	i_c2l_pll_perfcfg_3_2
1:0	R/W	0	i_c2l_pll_perfcfg_1_0

Table 13-7 reg32\_06 0x18

Bit(s)	R/W	Default	Description
31	R/W	0x1	hub_extra_bit_cntr
30:24	R/W	0	cntr_timeout
23	R/W	0	Internal_loopback
22	R/W	0	reg32_06_22_reserved
21	R/W	0	PCS_Reset_Transmit_State_machine
20	R/W	0	PCS_Reset_Receive_State_machine
19:16	R/W	0xf	fsls_farend_device_disconnect_micro_second_count_11_8
15:12	R/W	0xa	reg32_06_15_12_reserved
11:8	R/W	0	bypass_disc_cntr_3_0
7:0	R/W	0x17	PCS_microsecond_timer_done_count_value_7_0

Table 13-8 reg32\_07 0x1c

Bit(s)	R/W	Default	Description
31:24	RO	0	Prbs_Error_count
23:21	R/W	0	reg32_07_23_21_reserved
20:17	R/W	0xf	RX_ERROR_Turn_Around_Timer_Count
16	R/W	0	acceptable_bit_drops
15	R/W	0	host_tristate
14:12	R/W	0x4	fs_ls_minimum_count
11:8	R/W	0xf	cntr_done_value_7_4
7:4	R/W	0xf	cntr_done_value_3_0
3:0	R/W	0	HS_CDR_internal_tap_select

Table 13-9 reg32\_08 0x20

Bit(s)	R/W	Default	Description
31:24	R/W	0	Custom_Pattern_2
23:16	R/W	0	Custom_Pattern_1
15:8	R/W	0x4	Custom_Pattern_0
7	R/W	0	Enable_RX_ERROR_Timeout_Mode
6	R/W	0	reset_us_timer
5	R/W	0	PRBS_ERROR_Insert
4	R/W	0	PRBS_comparison_enable
3	R/W	0	PRBS_Enable
2:0	R/W	0	pattern

Table 13-10 reg32\_09 0x24

Bit(s)	R/W	Default	Description
31:24	R/W	0	Custom_Pattern_6
23:16	R/W	0	Custom_Pattern_5
15:8	R/W	0	Custom_Pattern_4
7:0	R/W	0	Custom_Pattern_3

Table 13-11 reg32\_10 0x28

Bit(s)	R/W	Default	Description
31:24	R/W	0	Custom_Pattern_10
23:16	R/W	0	Custom_Pattern_9

Bit(s)	R/W	Default	Description
15:8	R/W	0	Custom_Pattern_8
7:0	R/W	0	Custom_Pattern_7

Table 13-12 reg32\_11 0x2c

Bit(s)	R/W	Default	Description
31:24	R/W	0	Custom_Pattern_14
23:16	R/W	0	Custom_Pattern_13
15:8	R/W	0	Custom_Pattern_12
7:0	R/W	0	Custom_Pattern_11

Table 13-13 reg32\_12 0x30

Bit(s)	R/W	Default	Description
31:24	R/W	0	Custom_Pattern_18
23:16	R/W	0	Custom_Pattern_17
15:8	R/W	0	Custom_Pattern_16
7:0	R/W	0	Custom_Pattern_15

Table 13-14 reg32\_13 0x34

Bit(s)	R/W	Default	Description
31	R/W	0	reg32_13_31_reserved
30	R/W	0	bypass_reg[6]:i_c2l_fsls_rx_en
29	R/W	0	bypass_reg[5]:i_c2l_hs_rx_en
28	R/W	0	bypass_reg[4]:i_c2l_fs_oe
27	R/W	0	bypass_reg[3]:i_c2l_hs_oe
26	R/W	0	bypass_reg[2]:i_c2l_ls_en
25	R/W	0	bypass_reg[1]:i_c2l_fs_en
24	R/W	0	bypass_reg[0]:i_c2l_hs_en
23	R/W	0	Bypass_Host_Disconnect_Enable
22	R/W	0	Bypass_Host_Disconnect_Value
21	R/W	0	Clear_Hold_HS_disconnect
20:16	R/W	0x8	minimum_count_for_sync_detection
15	R/W	0	Update_PMA_signals
14	R/W	0	load_stat
13:8	R/W	0	reg32_13_13_8_reserved
7:0	R/W	0	Custom_Pattern_19



Table 13-15 reg32\_14 0x38

Bit(s)	R/W	Default	Description
31:24	R/W	0	Bypass_ctrl_15_8 bypass_ctrl[8]: bypass i_rpd_en bypass_ctrl[9]: bypass i_rpu_sw2_en bypass_ctrl[10]: i_rpu_sw1_en
23:16	R/W	0	Bypass_ctrl_7_0 bypass_ctrl[0]: hs bypass_ctrl[1]: fs bypass_ctrl[2]: ls bypass_ctrl[3]:hs_out_en bypass_ctrl[4]:fsls_out_en bypass_ctrl[5]:hs_rx_en bypass_ctrl[6]:hls_rx_en
15:8	R/W	0	reg32_14_7_reserved
7	R/W	0	i_c2l_assert_single_enable_zero
6	R/W	0	i_c2l_data_16_8
5	R/W	0	pg_rstn
4	R/W	0	bypass_reg[11:10]:i_rpu_sw1_en
3:2	R/W	0	bypass_reg[9]:i_rpu_sw2_en
1	R/W	0	bypass_reg[8]: i_rpd_en
0	R/W	0	i_rpd_en

Table 13-16 reg32\_15 0x3c

Bit(s)	R/W	Default	Description
31:29	R/W	0	reg32_15_31_29_reserved
28:16	R/W	0xfa0	ms_4_cntr
15:8	R/W	0x3c	non_se0_cntr
7:0	R/W	0x3c	se0_cntr

Table 13-17 reg32\_16 0x40

Bit(s)	R/W	Default	Description
31	RO	0	usb2_mppll_lock_dig
30	RO	0	usb2_mppll_lock
29	R/W	0	usb2_mppll_reset
28	R/W	0	usb2_mppll_en
27	R/W	0x1	usb2_mppll_fast_lock
26	R/W	0	usb2_mppll_lock_f
25:24	R/W	0x1	usb2_mppll_lock_long
23	R/W	0	usb2_mppll_dco_sdm_en
22	R/W	0x1	usb2_mppll_load
21	R/W	0	usb2_mppll_sdm_en
20	R/W	0	usb2_mppll_tdc_mode

Bit(s)	R/W	Default	Description
19:15	R/W	0	reg32_16_19_15_reserved
14:10	R/W	0x1	usb2_mppll_n
9	R/W	0	reg32_16_9_reserved
8:0	R/W	0x14	usb2_mppll_m

Table 13-18 reg32\_17 0x44

Bit(s)	R/W	Default	Description
31:28	R/W	0x9	usb2_mppll_filter_pvt1
27:24	R/W	0x2	usb2_mppll_filter_pvt2
23	R/W	0	usb2_mppll_filter_mode
22:20	R/W	0x7	usb2_mppll_lambda0
19:17	R/W	0x7	usb2_mppll_lambda1
16	R/W	0	usb2_mppll_fix_en
15:14	R/W	0	reg32_17_15_14_reserved
13:0	R/W	0	usb2_mppll_frac_in

Table 13-19 reg32\_18 0x48

Bit(s)	R/W	Default	Description
31	R/W	0	usb2_mppll_acg_range
30:29	R/W	0x3	usb2_mppll_adj_ldo
28:26	R/W	0x3	usb2_mppll_alpha
25:24	R/W	0x1	usb2_mppll_bb_mode
23:22	R/W	0x1	usb2_mppll_bias_adj
21:19	R/W	0x3	usb2_mppll_data_sel
18:16	R/W	0x3	usb2_mppll_rou
15:14	R/W	0	usb2_mppll_pfd_gain
13	R/W	0x1	usb2_mppll_dco_clk_sel
12	R/W	0	usb2_mppll_dco_m_en
11:6	R/W	0x27	usb2_mppll_lk_s
5:2	R/W	0x9	usb2_mppll_lk_w
1:0	R/W	0x1	usb2_mppll_lkw_sel

Table 13-20 reg32\_19 0x4c

Bit(s)	R/W	Default	Description
31	RO	0	usb2_mppll_lock_dig
30	RO	0	usb2_mppll_lock
29:10	RO	0	reg32_19_29_10_reserved
9:0	RO	0	usb2_mppll_reg_out

Table 13-21 reg32\_20 0x50

Bit(s)	R/W	Default	Description
31	R/W	0	bypass_cal_done_r5
30:29	R/W	0	usb2_bgr_dbg_1_0
28:24	R/W	0	usb2_bgr_vref_4_0
23:22	R/W	0	squelch_sel: 01: debounce 1; 10: debounce 2; 00/11: no debounce
21	R/W	0	usb2_bgr_start
20:16	R/W	0	usb2_bgr_adj_4_0
15:14	R/W	0	usb2_edgedrv_trim_1_0
13	R/W	0	usb2_edgedrv_en
12:9	R/W	0xf	usb2_dmon_sel_3_0
8	R/W	0	usb2_dmon_en
7	R/W	0	bypass_otg_det
6	R/W	0	usb2_cal_code_r5
5	R/W	0	usb2_amon_en
4	R/W	0x1	usb2_otg_vbusdet_en
3:1	R/W	0x4	usb2_otg_vbus_trim_2_0
0	R/W	0	usb2_otg_iddet_en

Table 13-22 reg32\_21 0x54

Bit(s)	R/W	Default	Description
31:26	R/W	0	reg32_21_31_26_reserved
25:20	R/W	0	bypass_utmi_reg [21:20]: xcvr_select ctrl reg [22]: term_select ctrl reg [23]: suspend ctrl reg [25:24]: opmode ctrl reg
19:16	R/W	0	bypass_utmi_cntr [16]: bypass xcvr_select [17]: bypass term_select [18]: bypass suspend [19]: bypass opmode
15:8	R/W	0	hs cdr ctrl
7	R/W		hs cdr sel
6	R/W		reg32_21_6_reserved
5:4	R/W	0x2	usb2_otg_aca_trim_1_0

Bit(s)	R/W	Default	Description
3	R/W	0	usb2_tx_strg_pd
2	R/W	0x1	usb2_otg_aca_en
1	R/W	0x1	usb2_cal_ack_en
0	R/W	0	usb2_bgr_force

Table 13-23 reg32\_22 0x58

Bit(s)	R/W	Default	Description
31:14	RO	0	reg32_22_31_14_reserved
[13:6]			hs cdr state
5:3	RO	0	usb2_otg_aca_iddig
2	RO	0	usb2_otg_vbus_vld
1	RO	0	usb2_otg_sess_vld
0	RO	0	usb2_otg_id_dig

Table 13-24 reg32\_23 0x5c

Bit(s)	R/W	Default	Description
31:16	RO	0	test_bus_data_int_15_0
15:13		0	ldo_trim
12		1	ldo_en
11		0	new_hs_disc_ctrl[1]
10		0	new_hs_disc_ctrl[0]
9		0	sel_cdr
8		0	pcs_sel
7	R/W	0	orw_test_bus_en
6:1	R/W	0	orw_test_bus_sel_5_0
0	R/W	0	orw_usb2_bgr_en

## 13.2 PCIE

PCIE module includes PCIE controller and PCIE PHY.

## 13.3 Ethernet

### 13.3.1 Overview

The Ethernet MAC controller provides a complete Ethernet interface from the chip to a Reduced Gigabit Media Independent Interface(RGMII) compliant Ethernet PHY.

## 13.3.2 Ethernet MAC

### 13.3.2.1 Features

Ethernet MAC has the following features:

- 10/100/1000 MAC 3.70a
- RGMII/RMII
- AHB 32 Bits internal bus
- RX FIFO 4KB, TX FIFO 2KB
- 2 MAC addresses
- EEE
- Power Management

### 13.3.2.2 Register Description

Table 13-25 PRG\_ETH\_REG0 0xff634540

Bit(s)	R/W	Default	Description
31	R/W	0	Set AHB to DDR interface as urgent.
30	R/W	0	RGMII mode Use RX_CLK as TX_CLK.
29-27	R/W	0	RMII & RGMII mode Select one signal from {RXDV, RXD[3:0]} to calibrate.
26	R/W	0	RMII & RGMII mode 0: test falling edge 1: test rising edge
25	R/W	0	RMII & RGMII mode Start calibration logic
24-20	R/W	0	RMII & RGMII mode 5 Bits correspondent to {RXDV, RXD[3:0]}, set to 1 will delay the data capture by 1 cycle.
19-15	R/W	0	Set bit14 to 0. RMII & RGMII mode Capture input data at clock index equal to adj_delay.
14	R/W	0	Set RXDV and RXD setup time, data is aligned with index 0. When set to 1, auto delay and skew
13	R/W	0	RMII & RGMII mode Enable data delay adjustment and calibration logic.
12	R/W	0	RMII & RGMII mode Enable TX_CLK and PHY_REF_CLK generator.
11	R/W	0	RMII mode Use inverted internal clk_rmii_i to generate 25/2.5 tx_rx_clk.
10	R/W	0	Generate 25MHz clock for PHY
9-7	R/W	0	RMII & RGMII mode, 000: invalid value. 001: mp2_clk_out is 250MHz. 010: mp2_clk_out is 500MHz. ... Mp2_clk_out is "ratio" *250MHz.
6-5	R/W	0	RGMII mode,

Bit(s)	R/W	Default	Description
			TX_CLK related to TXD 00: clock delay 0 cycle. 01: clock delay ¼ cycle. 10: clock delay ½ cycle. 11: clock delay ¾ cycle.
4	R	0	Unused
3	R/W	0	RMII mode CLK_RMII RGMII mode RX_CLK Use inverted signal when set to 1.
2	R/W	0	Sideband Descriptor Endianness Control Function: When set high, this signal configures the DMA to transfer descriptors in reverse endianness of the data format. When low (by default), the descriptors are transferred in the same endian format as the data. This signal is sampled during active reset (including soft-reset) only and ignored after reset is de-asserted.
1	R/W	0	Sideband Data Endianness Control Function: When set high, this signal configures the DMA to transfer data in big-endian format. When low (by default), the data is transferred in little-endian format. This signal is sampled during active reset (including soft-reset) only and ignored after reset is de-asserted.
0	R/W	0	PHY Interface Select Function: These pins select one of the multiple PHY interfaces of MAC. This is sampled only during reset assertion and ignored after that. 1: internal value 001: RGMII 0: internal value 100: RMII

Table 13-26 PRG\_ETH\_REG1 0xff634544

Bit(s)	R/W	Default	Description
31-16	R	0	Unused
15	R/W	0	The result is valid
14	R/W	0	The results is rising edge test or falling edge test.
13-11	R/W	0	The signal under test.
10	R/W	0	The Calibration logic is waiting for event.
9-5	R/W	0	The RX_CLK length in 1ns.
4-0	R/W	0	Signal switch position in 1ns.

### 13.3.3 Ethernet PHY

#### 13.3.3.1 Features

Ethernet PHY has the following features:

- Integrated IEEE 802.3/802.3u compliant 10/100Mbps Ethernet PHY
- Supporting both full and half-duplex for either 10 or 100 Mb/s data rate
- Auto MDIX capable
- Supports wake-on-LAN
- 100 Base-T support
- MII/RMII/SMII interface

- Supports auto-negotiation
- Full set of power down modes
- Interface available to 100Base-FX Fiber-PMD
- Serial Management Interface (SMI)
- Fix configurations for LED status indicators
- Supporting military temperature range -20°C to 80°C
- Perfect mix of analog and digital lends itself to robustness, portability, and performance
- Multiple input clock options
- Stand-alone core

### 13.3.3.2 Register Description

**Table 13-27 ETH\_PHY\_DBG\_CTL0 0xFF64C000**

Bit(s)	R/W	Default	Description
[7:0]	R/W	0	ETH digital debug registers

**Table 13-28 ETH\_PHY\_DBG\_CTL1**

Bit(s)	R/W	Default	Description
[23:0]	R/W	0	ETH digital debug registers

**Table 13-29 ETH\_PHY\_DBG\_CFG0 0xFF64C008**

Bit(s)	R/W	Default	Description
[31:0]	R/W	0	ETH digital debug registers

**Table 13-30 ETH\_PHY\_DBG\_CFG1 0xFF64C00c**

Bit(s)	R/W	Default	Description
[31:0]	R/W	0	ETH digital debug registers

**Table 13-31 ETH\_PHY\_DBG\_CFG2 0xFF64C010**

Bit(s)	R/W	Default	Description
[31:0]	R/W	0	ETH digital debug registers

**Table 13-32 ETH\_PHY\_DBG\_CFG3 0xFF64C014**

Bit(s)	R/W	Default	Description
[31:0]	R/W	0	ETH digital debug registers

**Table 13-33 ETH\_PHY\_DBG\_CFG4 0xFF64C018**

Bit(s)	R/W	Default	Description
[31:0]	R/W	0	ETH digital debug registers

**Table 13-34 ETH\_PLL\_STS 0xFF64C040**

Bit(s)	R/W	Default	Description
[31]	R		eth_mppll_lock
[30]	R		eth_mppll_lock_dig
[29:10]	R		reserved
[9:0]	R		eth_mppll_reg_out

**Table 13-35 ETH\_PLL\_CTL0 0xFF64C044**

Bit(s)	R/W	Default	Description
[31]	R		eth_mppll_lock
[30]	R		eth_mppll_lock_dig
[29]	R/W		eth_mppll_reset
[28]	R/W		eth_mppll_en
[27]	R/W		eth_mppll_fast_lock
[26]	R/W		eth_mppll_lock_f
[25:24]	R/W		eth_mppll_lock_long
[23]	R/W		eth_mppll_sel_ref
[22]	R/W		eth_mppll_load
[21]	R/W		eth_mppll_sdm_en
[20]	R/W		eth_mppll_tdc_mode
[19:15]	R/W		reserved
[14:10]	R/W		eth_mppll_n
[9]	R/W		reserved
[8:0]	R/W		eth_mppll_m

**Table 13-36 ETH\_PLL\_CTL1 0xFF64C048**

Bit(s)	R/W	Default	Description
[31:28]	R/W		eth_mppll_filter_pvt1
[27:24]	R/W		eth_mppll_filter_pvt2
[23]	R/W		eth_mppll_filter_mode
[22:20]	R/W		eth_mppll_lambda0
[19:17]	R/W		eth_mppll_lambda1



Bit(s)	R/W	Default	Description
[16]	R/W		eth_mppll_fix_en
[15:14]	R/W		reserved
[13:0]	R/W		eth_mppll_frac_in

Table 13-37 ETH\_PLL\_CTL2 0xFF64C04C

Bit(s)	R/W	Default	Description
[31]	R/W		eth_mppll_acq_range
[30:29]	R/W		eth_mppll_adj_ldo
[28:26]	R/W		eth_mppll_alpha
[25:24]	R/W		eth_mppll_bb_mode
[23:22]	R/W		eth_mppll_bias_adj
[21:19]	R/W		eth_mppll_data_sel
[18:16]	R/W		eth_mppll_rou
[15:14]	R/W		eth_mppll_pfd_gain
[13]	R/W		eth_mppll_dco_clk_sel
[12]	R/W		eth_mppll_dco_m_en
[11:6]	R/W		eth_mppll_lk_s
[5:2]	R/W		eth_mppll_lk_w
[1:0]	R/W		eth_mppll_lkw_sel

Table 13-38 ETH\_PLL\_CTL3 0xFF64C050

Bit(s)	R/W	Default	Description
[31:1]	R		reserved
[0]	R/W		eth_mppll_dco_sdm_en

Table 13-39 ETH\_PLL\_CTL4 0xFF64C054

Bit(s)	R/W	Default	Description
[31:0]	R/W		reserved

Table 13-40 ETH\_PLL\_CTL5 0xFF64C058

Bit(s)	R/W	Default	Description
[31:16]	R/W	0	ETH_PHY_RXADC0
[15:3]	R/W	0	ETH_PHY_CTLIO
[2:0]	R/W	0	reserved

**Table 13-41 ETH\_PLL\_CTL6 0xFF64C05C**

Bit(s)	R/W	Default	Description
[31:16]	R/W	0	reserved
[15:0]	R/W	0	ETH_PHY_RXSQLD

**Table 13-42 ETH\_PLL\_CTL7 0xFF64C060**

Bit(s)	R/W	Default	Description
[31:16]	R/W	0	reserved
[15:0]	R/W	0	ETH_PHY_RXADC1

**Table 13-43 ETH\_PHY\_CNTL0 0xFF64C080**

Bit(s)	R/W	Default	Description
[31:16]	R/W	0	co_reg3_oui_in, SMI register 3 default value
[15:0]	R/W	0	co_reg2_oui_in, SMI register 2 default value

**Table 13-44 ETH\_PHY\_CNTL1 0xFF64C084**

Bit(s)	R/W	Default	Description
[31:24]	R/W	0	led_cfg, led_cfg[7:5]: co_activity_led output select
[23]	R/W	0	reserved
[22]	R/W	0	co_pwruprst_byp
[21]	R/W	0	co_clk_ext
[20]	R/W	0	co_st_scan
[19]	R/W	0	co_rxclk_inv
[18]	R/W	0	co_phy_enb
[17]	R/W	0	co_clkfreq
[16]	R/W	0	eth_clk_enable
[15:14]	R/W	0	co_st_miimode[1:0]
[13]	R/W	0	co_smii_source_sync
[12]	R/W	0	co_st_pllbp
[11]	R/W	0	co_st_adcbp
[10]	R/W	0	co_st_fxmode
[9]	R/W	0	co_en_high
[8]	R/W	0	co_automdix_en
[7:3]	R/W	0	co_st_phyadd[4:0]
[2:0]	R/W	0	co_st_mode[2:0]

**Table 13-45 ETH\_PHY\_CNTL2 0xFF64C088**

Bit(s)	R/W	Default	Description
[31]	R/W	0	reserved
[30]	R/W	0	eth_phy_clk25min_en:
[29:28]	R/W	0	reserved
[27:24]	R/W	0	debug output bus select
[23:13]	R/W	0	reserved
[12]	R/W	0	analog production test mode enable
[11]	R/W	0	mdi source select
[10]	R/W	0	reserved
[9]	R/W	0	source select for rx_clk to mac
[8]	R/W	0	source select for tx_clk output to gpio
[7]	R/W	0	rx_dv/col switch for mac
[6]	R/W	0	ephy smi source select
[5]	R/W	0	use internal phy
[4]	R/W	0	ephy smi source select
[3]	R/W	0	co_clkin source select
[2]	R/W	0	co_mdclk source select
[1]	R/W	0	enable reset in test mode
[0]	R/W	0	ephy loopback mode enable, in/out through debug in/out gpio

**Table 13-46 ETH\_PHY\_STS0 0xFF64C094**

Bit(s)	R/W	Default	Description
[31:28]	R		reserved
[27:19]	R		co_int_vec[8:0]
[19]	R		reserved
[18:0]	R		ETH_PLL_STS[18:0]

**Table 13-47 ETH\_PHY\_STS1 0xFF64C098**

Bit(s)	R/W	Default	Description
[31:0]	R		eth_phy_dbg_prb

**Table 13-48 ETH\_PHY\_STS2 0xFF64C09C**

Bit(s)	R/W	Default	Description
[31:26]	R		eth_phy_rxda[5:0]
[25]	R		eth_phy_rxadcoflw

Bit(s)	R/W	Default	Description
[24]	R		eth_phy_rxadcflw
[23]	R		eth_phy_rxprepga
[22:20]	R		eth_phy_rxgain[2:0]
[19:0]	R		eth_test_status

Table 13-49 ETH\_PHY\_DBG\_REG 0xFF64C0A0

Bit(s)	R/W	Default	Description
[31:16]	R		eth_phy_dbg_reg
[15:8]			reserved
[7:0]	R/W	0	eth_phy_dbg_reg_mux

## 13.4 Inter-Integrated Circuit (I2C)

### 13.4.1 Overview

Inter-Integrated Circuit (IIC or I2C) is a multi-slave serial communication bus between ICs. The chip integrates the I2C interface and signals allowing communications with other I2C peripheral devices.

### 13.4.2 Features

The I2C Master Module has the following features:

- Support for 7-bit and 10-bit addressable devices
- Programmable bus speed including standard speed (100 KBits/s) and fast speed (400 KBits/s)
- Error transfer detection
- “Transfer complete” indication by polling or interrupt (Interrupts handled by the ISA module).
- Internal buffer holding up to 8 bytes for transfer (in either direction)
- Flexible architecture allowing the software to dictate the format of the I2C bit streams
- Manual setting of the I2C bus to accommodate a software only mode

### 13.4.3 Register Description

For I2C module in EE domain, each register final address = 0x FF805000 + offset \* 4 for master mode, final address = 0x FF806000 + offset \* 4 for slave mode.

Table 13-50 I2C\_M\_0\_CONTROL\_REG 0x7c00

Bit(s)	R/W	Default	Description
31	R/W	0	CNTL_JIC: There is internal logic to dynamically enable the gated clocks. If this gated clock logic doesn't work, you can set This bit to always enable the clock. Setting This bit wastes power.
30	R	0	Unused
29-28	R/W	0	QTR_CLK_EXT: These two Bits extend the clock divider to 12 Bits: QTR_CLK = {[29:28],[21:12]}

Bit(s)	R/W	Default	Description
27	R	0	unused
26	R	0	Read back level of the SDA line
25	R	0	Read back level of the SCL line
24	R/W	0	Sets the level of the SDA line if manual mode is enabled. If This bit is '0', then the SDA line is pulled low. If This bit is '1' then the SDA line is tri-stated.
23	R/W	0	Sets the level of the SCL line if manual mode is enabled. If This bit is '0', then the SCL line is pulled low. If This bit is '1' then the SCL line is tri-stated.
22	R/W	0	This bit is used to enable manual mode. Manual I2C mode is controlled by Bits 12,13,14 and 15 above.
21:12	R/W	0x142	QTR_CLK_DLY: This value corresponds to period of the SCL clock divided by 4 Quarter Clock Delay = * System Clock Frequency For example, if the system clock is 133Mhz, and the I2C clock period is 10uS (100khz), then Quarter Clock Delay = * 133 Mhz = 332
11:8	R	-	READ_DATA_COUNT: This value corresponds to the number of bytes READ over the I2C bus. If this value is zero, then no data has been read. If this value is 1, then Bits [7:0] in TOKEN_RDATA_REG0 contains valid data. The software can read this register after an I2C transaction to get the number of bytes to read from the I2C device.
7:4	R	-	CURRENT_TOKEN: This value reflects the current token being processed. In the event of an error, the software can use this value to determine the error location.
3	R	-	ERROR: This read only Bit is set if the I2C device generates a NACK during writing. This bit is cleared at on the clock cycle after the START Bit is set to 1 indicating the start of list processing. Errors can be ignored by setting the ACK_IGNORE Bit(s) below. Errors will be generated on Writes to devices that return NACK instead of ACK. A NACK is returned by a device if it is unable to accept any more data (for example because it is processing some other real-time function). In the event of an ERROR, the I2C module will automatically generate a STOP condition on the bus.
2	R	-	STATUS: This bit reflects the status of the List processor: 0: IDLE 1: Running. The list processor will enter this state on the clock cycle after the START Bit is set. The software can poll the status register to determine when processing is complete.
1	R/W	0	ACK_IGNORE: Set to 1 to disable I2C ACK detection. The I2C bus uses an ACK signal after every byte transfer to detect problems during the transfer. Current Software implementations of the I2C bus ignore this ACK. This bit is for compatibility with the current Amlogic software. This bit should be set to 0 to allow NACK operations to abort I2C bus transactions. If a NACK occurs, the ERROR bit above will be set.
0	R/W	0	START: Set to 1 to start list processing. Setting This bit to 0 while the list processor is operating causes the list processor to abort the current I2C operation and generate an I2C STOP command on the I2C bus. Normally This bit is set to 1 and left high until processing is complete. To re-start the list processor with a new list (after a previous list has been exhausted), simply set This bit to zero then to one.

Table 13-51 I2C\_M\_0\_SLAVE ADDRESS 0x7c01

Bit(s)	R/W	Default	Description
31:29	R	0	Reserved
28	R/W	0	USE_CNTL_SCL_LOW: If This bit is set to 1, then Bits[27:16] control the SCL low time.

Bit(s)	R/W	Default	Description
27:16	R/W	0	SCL Low delay.
15:14	R	0	Unused
13-11	R/W	0	SCL_FILTER: A filter was added in the SCL input path to allow for filtering of slow rise times. 0 = no filtering, 7 = max filtering
10:8	R/W	0	SDA FILTER: A filter was added in the SDA input path to allow for filtering of slow rise times. 0 = no filtering, 7 = max filtering
7:0	R/W	0x00	SLAVE_ADDRESS. This is a 7-bit value for a 7-bit I2C device, or (0xF0   {A9, A8}) for a 10-bit I2C device. By convention, the slave address is typically stored in by first left shifting it so that it's MSB is D7 (The I2C bus assumes the 7-bit address is left shifted one). Additionally, since the SLAVE address is always an 7-bit value, D0 is always 0. NOTE: The I2C always transfers 8-bits even for address. The I2C hardware will use D0 to dictate the direction of the bus. Therefore, D0 should always be '0' when this register is set.

The register below describes the first 8 tokens in the token list.

**Table 13-52 I2C\_M\_0\_TOKEN\_LIST\_REG0 0x7c02**

Bit(s)	R/W	Default	Description
31:28	R/W	0x00	8th token in the list to process
27:24	R/W	0x00	7th token in the list to process
23:20	R/W	0x00	6th token in the list to process
19:16	R/W	0x00	5th token in the list to process
15:12	R/W	0x00	4th token in the list to process
11:8	R/W	0x00	3rd token in the list to process
7:4	R/W	0x00	2nd token in the list to process
3:0	R/W	0x00	1st token in the list to process (See the table below for token definitions)

**Table 13-53 Token Definitions**

Command Token	Value	Data	Description
END	0x0	N/A	Used to tell the I2C module that this is the end of the Token list. This token is not associated with the I2C bus, but rather with the state-machine that drives the token list processor.
START	0x1	N/A	The START Token is used to tell an I2C device that this is the beginning of an I2C transfer
SLAVE_ADDR--WRITE	0x2	7-bits	This bit-sequence is used to address a device and tell the device it is being WRITTEN
SLAVE_ADDR--READ	0x3	7-bits	This bit sequence is used to address a device and tell the device it is being READ.
DATA	0x4	8-bits	This 8-bit byte sequence is a byte transfer (READ or WRITE). The DATA token corresponds to a WRITE if it follows a SLAVE_ADDR-WRITE token. The DATA token corresponds to a READ if it follows a SLAVE_ADDR-READ token.

Command Token	Value	Data	Description
DATA-LAST	0x5	8-bits	Used to indicate the last 8-bit byte transfer is a byte transfer of a READ.
STOP	0x6	N/A	This tells the I2C device it is no longer being addressed

Write data associated with the DATA token should be placed into the I2C\_TOKEN\_WDATA\_REG0 or I2C\_TOKEN\_WDATA\_REG1 registers. Read data associated with the DATA or DATA-LAST token can be read from the I2C\_TOKEN\_RDATA\_REG0 or I2C\_TOKEN\_RDATA\_REG1 registers.

**Table 13-54 I2C\_M\_0\_TOKEN\_LIST\_REG1 0x7c03**

Bit(s)	R/W	Default	Description
31:28	R/W	0x00	16th token in the list to process
27:24	R/W	0x00	15th token in the list to process
23:20	R/W	0x00	14th token in the list to process
19:16	R/W	0x00	13th token in the list to process
15:12	R/W	0x00	12th token in the list to process
11:8	R/W	0x00	11th token in the list to process
7:4	R/W	0x00	10th token in the list to process
3:0	R/W	0x00	9th token in the list to process

**Table 13-55 I2C\_M\_0\_TOKEN\_WDATA\_REG0 0x7c04**

Bit(s)	R/W	Default	Description
31:24	R/W	0x00	4th data byte written for a DATA (write) token.
23:16	R/W	0x00	3rd data byte written for a DATA (write) token.
15:8	R/W	0x00	2nd data byte written for a DATA (write) token.
7:0	R/W	0x00	1st data byte written for a DATA (write) token.

**Table 13-56 I2C\_M\_0\_TOKEN\_WDATA\_REG1 0x7c05**

Bit(s)	R/W	Default	Description
31:24	R/W	0x00	8th data byte written for a DATA (write) token.
23:16	R/W	0x00	7th data byte written for a DATA (write) token.
15:8	R/W	0x00	6th data byte written for a DATA (write) token.
7:0	R/W	0x00	5th data byte written for a DATA (write) token.

**Table 13-57 I2C\_M\_0\_TOKEN\_RDATA\_REG0 0x7c06**

Bit(s)	R/W	Default	Description
31:24	R/W	0x00	4th data byte read for a DATA or DATA-LAST (READ) token.
23:16	R/W	0x00	3rd data byte read for a DATA or DATA-LAST (READ) token.

Bit(s)	R/W	Default	Description
15:8	R/W	0x00	2nd data byte read for a DATA or DATA-LAST (READ) token.
7:0	R/W	0x00	1st data byte read for a DATA or DATA-LAST (READ) token.

Table 13-58 I2C\_M\_0\_TOKEN\_RDATA\_REG1 0x7c07

Bit(s)	R/W	Default	Description
31:24	R/W	0x00	8th data byte read for a DATA or DATA-LAST (READ) token.
23:16	R/W	0x00	7th data byte read for a DATA or DATA-LAST (READ) token.
15:8	R/W	0x00	6th data byte read for a DATA or DATA-LAST (READ) token.
7:0	R/W	0x00	5th data byte read for a DATA or DATA-LAST (READ) token.

I2C\_M\_1\_ 0x7800~0x7807

See I2C\_M\_0

I2C\_M\_2\_ 0x7400~0x7407

See I2C\_M\_0

I2C\_M\_3\_ 0x7000~0x7007

See I2C\_M\_0

For I2C module in AO domain, each register final address = 0xFF805000 + offset \* 4 for master mode, final address = 0x FF806000 + offset \* 4 for slave mode.

Table 13-59 AO\_I2C\_M\_0\_CONTROL\_REG 0x0

Bit(s)	R/W	Default	Description
31	R/W	0	CNTL_JIC: There is internal logic to dynamically enable the gated clocks. If this gated clock logic doesn't work, you can set this bit to always enable the clock. Setting this bit wastes power.
30	R	0	Unused
29-28	R/W	0	QTR_CLK_EXT: These two bits extend the clock divider to 12 bits: QTR_CLK = {[29:28],[21:12]}
27	R	0	unused
26	R	0	Read back level of the SDA line
25	R	0	Read back level of the SCL line
24	R/W	0	Sets the level of the SDA line if manual mode is enabled. If this bit is '0', then the SDA line is pulled low. If this bit is '1' then the SDA line is tri-stated.
23	R/W	0	Sets the level of the SCL line if manual mode is enabled. If this bit is '0', then the SCL line is pulled low. If this bit is '1' then the SCL line is tri-stated.
22	R/W	0	This bit is used to enable manual mode. Manual I2C mode is controlled by bits 12,13,14 and 15 above.
21:12	R/W	0x142	QTR_CLK_DLY. This value corresponds to period of the SCL clock divided by 4 Quarter Clock Delay = * System Clock Frequency For example, if the system clock is 133Mhz, and the I2C clock period is 10uS (100khz), then Quarter Clock Delay = * 133 Mhz = 332



Bit(s)	R/W	Default	Description
11:8	R	-	READ_DATA_COUNT: This value corresponds to the number of bytes READ over the I2C bus. If this value is zero, then no data has been read. If this value is 1, then bits [7:0] in TOKEN_RDATA_REG0 contains valid data. The software can read this register after an I2C transaction to get the number of bytes to read from the I2C device.
7:4	R	-	CURRENT_TOKEN: This value reflects the current token being processed. In the event of an error, the software can use this value to determine the error location.
3	R	-	ERROR: This read only bit is set if the I2C device generates a NACK during writing. This bit is cleared at on the clock cycle after the START bit is set to 1 indicating the start of list processing. Errors can be ignored by setting the ACK_IGNORE bit below. Errors will be generated on Writes to devices that return NACK instead of ACK. A NACK is returned by a device if it is unable to accept any more data (for example because it is processing some other real-time function). In the event of an ERROR, the I2C module will automatically generate a STOP condition on the bus.
2	R	-	STATUS: This bit reflects the status of the List processor: 0: IDLE 1: Running. The list processor will enter this state on the clock cycle after the START bit is set. The software can poll the status register to determine when processing is complete.
1	R/W	0	ACK_IGNORE: Set to 1 to disable I2C ACK detection. The I2C bus uses an ACK signal after every byte transfer to detect problems during the transfer. Current Software implementations of the I2C bus ignore this ACK. This bit is for compatibility with the current Amlogic software. This bit should be set to 0 to allow NACK operations to abort I2C bus transactions. If a NACK occurs, the ERROR bit above will be set.
0	R/W	0	START: Set to 1 to start list processing. Setting this bit to 0 while the list processor is operating causes the list processor to abort the current I2C operation and generate an I2C STOP command on the I2C bus. Normally this bit is set to 1 and left high until processing is complete. To re-start the list processor with a new list (after a previous list has been exhausted), simply set this bit to zero then to one.

Table 13-60 AO\_I2C\_M\_0\_SLAVE\_ADDR 0x1

Bit(s)	R/W	Default	Description
31:29	R	0	Unused
28	R/W	0	USE_CNTL_SCL_LOW: If this bit is set to 1, then bits[27:16] control the SCL low time.
27:16	R/W	0	SCL Low delay. This is a new feature in M8baby. In the previous M8baby design, the SCL low time was controlled by bits[21:12] of the register above. In this design, the SCL delay is controlled independently by these bits.
15:14	R	0	Unused
13:11	R/W	0	SCL_FILTER: A filter was added in the SCL input path to allow for filtering of slow rise times. 0 = no filtering, 7 = max filtering
10:8	R/W	0	SDA_FILTER: A filter was added in the SDA input path to allow for filtering of slow rise times. 0 = no filtering, 7 = max filtering
7:0	R/W	0x00	SLAVE_ADDRESS. This is a 7-bit value for a 7-bit I2C device, or (0xF0   {A9, A8}) for a 10-bit I2C device. By convention, the slave address is typically stored in by first left shifting it so that it's MSB is D7 (The I2C bus assumes the 7-bit address is left shifted one). Additionally, since the SLAVE address is always a 7-bit value, D0 is always 0. NOTE: The I2C always transfers 8-bits even for address. The I2C hardware will use D0 to dictate the direction of the bus. Therefore, D0 should always be '0' when this register is set.

The register below describes the first 8 tokens in the token list.

**Table 13-61 AO\_I2C\_M\_0\_TOKEN\_LIST0 0x2**

Bit(s)	R/W	Default	Description
31:28	R/W	0x00	8th token in the list to process
27:24	R/W	0x00	7th token in the list to process
23:20	R/W	0x00	6th token in the list to process
19:16	R/W	0x00	5th token in the list to process
15:12	R/W	0x00	4th token in the list to process
11:8	R/W	0x00	3rd token in the list to process
7:4	R/W	0x00	2nd token in the list to process
3:0	R/W	0x00	1st token in the list to process (See the table below for token definitions)

**Table 13-62 Token Definitions**

Command Token	Value	Data	Description
END	0x0	N/A	Used to tell the I2C module that this is the end of the Token list. This token is not associated with the I2C bus, but rather with the state-machine that drives the token list processor.
START	0x1	N/A	The START Token is used to tell an I2C device that this is the beginning of an I2C transfer
SLAVE_ADDR--WRITE	0x2	7-bits	This bit-sequence is used to address a device and tell the device it is being WRITTEN
SLAVE_ADDR--READ	0x3	7-bits	This bit sequence is used to address a device and tell the device it is being READ.
DATA	0x4	8-bits	This 8-bit byte sequence is a byte transfer (READ or WRITE). The DATA token corresponds to a WRITE if it follows a SLAVE_ADDR-WRITE token. The DATA token corresponds to a READ if it follows a SLAVE_ADDR-READ token.
DATA-LAST	0x5	8-bits	Used to indicate the last 8-bit byte transfer is a byte transfer of a READ.
STOP	0x6	N/A	This tells the I2C device it is no longer being addressed

Write data associated with the DATA token should be placed into the I2C\_TOKEN\_WDATA\_REG0 or I2C\_TOKEN\_WDATA\_REG1 registers. Read data associated with the DATA or DATA-LAST token can be read from the I2C\_TOKEN\_RDATA\_REG0 or I2C\_TOKEN\_RDATA\_REG1 registers.

**Table 13-63 AO\_I2C\_M\_0\_TOKEN\_LIST1 0x3**

Bit(s)	R/W	Default	Description
31:28	R/W	0x00	16th token in the list to process
27:24	R/W	0x00	15th token in the list to process
23:20	R/W	0x00	14th token in the list to process

Bit(s)	R/W	Default	Description
19:16	R/W	0x00	13th token in the list to process
15:12	R/W	0x00	12th token in the list to process
11:8	R/W	0x00	11th token in the list to process
7:4	R/W	0x00	10th token in the list to process
3:0	R/W	0x00	9th token in the list to process

Table 13-64 AO\_I2C\_M\_0\_WDATA\_REG0 0x4

Bit(s)	R/W	Default	Description
31:24	R/W	0x00	4th data byte written for a DATA (write) token.
23:16	R/W	0x00	3rd data byte written for a DATA (write) token.
15:8	R/W	0x00	2nd data byte written for a DATA (write) token.
7:0	R/W	0x00	1st data byte written for a DATA (write) token.

Table 13-65 AO\_I2C\_M\_0\_WDATA\_REG1 0x5

Bit(s)	R/W	Default	Description
31:24	R/W	0x00	8th data byte written for a DATA (write) token.
23:16	R/W	0x00	7th data byte written for a DATA (write) token.
15:8	R/W	0x00	6th data byte written for a DATA (write) token.
7:0	R/W	0x00	5th data byte written for a DATA (write) token.

Table 13-66 AO\_I2C\_M\_0\_RDATA\_REG0 0x6

Bit(s)	R/W	Default	Description
31:24	R/W	0x00	4th data byte read for a DATA or DATA-LAST (READ) token.
23:16	R/W	0x00	3rd data byte read for a DATA or DATA-LAST (READ) token.
15:8	R/W	0x00	2nd data byte read for a DATA or DATA-LAST (READ) token.
7:0	R/W	0x00	1st data byte read for a DATA or DATA-LAST (READ) token.

Table 13-67 AO\_I2C\_M\_0\_RDATA\_REG1 0x7

Bit(s)	R/W	Default	Description
31:24	R/W	0x00	8th data byte read for a DATA or DATA-LAST (READ) token.
23:16	R/W	0x00	7th data byte read for a DATA or DATA-LAST (READ) token.
15:8	R/W	0x00	6th data byte read for a DATA or DATA-LAST (READ) token.
7:0	R/W	0x00	5th data byte read for a DATA or DATA-LAST (READ) token.

**Table 13-68 AO\_I2C\_M\_0\_TIMEOUT\_TH 0x8**

Bit(s)	R/W	Default	Description
31:24	R/W	0x00	8th data byte read for a DATA or DATA-LAST (READ) token.
23:16	R/W	0x00	7th data byte read for a DATA or DATA-LAST (READ) token.
15:8	R/W	0x00	6th data byte read for a DATA or DATA-LAST (READ) token.
7:0	R/W	0x00	5th data byte read for a DATA or DATA-LAST (READ) token.

**Table 13-69 AO\_I2C\_S\_CONTROL\_REG 0x0**

Bit(s)	R/W	Default	Description
31-29	R	0	REG POINTER: There are 5 internal registers inside the I2C slave module. The I2C Master sets this value using the byte that follows the address byte in the I2C data stream. Register 4 (numbered 0,1,...4) is the status register.
28	R/W	0	SEND READY: This bit is set to '1' by the ARC to indicate to the slave machine that the I2C slave module is ready to send data. This bit is cleared by the I2C module when it has sent 4 bytes to the I2C master. This bit is also available in the status register that can be read by the I2C master. The I2C master can read the status register to see when the I2C slave module has data to send.
27	R/W	0	RECEIVE READY: This bit is set to '1' by the ARC to indicate to the slave machine that the I2C slave module is ready to receive data. This bit is cleared by the I2C module when it has received 4 bytes from the I2C master. This bit is also available in the status register that can be read by the I2C master. The I2C master can read the status register to see when the I2C slave module is ready to receive data.
26	R	0	BUSY: Read only status bit. '1' indicates that the I2C slave module is sending or receiving data.
25	R/W	0	IRQ_EN: If this bit is set, then an interrupt will be sent to the ARC whenever 4 bytes have been read or 4 bytes have been written to the I2C slave module.
24	R/W	0	ACK Always: Typically the ACK of a slave I2C device is dependent upon the availability of data (if reading) and room to store data (when we are being written). Our I2C module has a status register that can be read continuously. This bit can be set if the I2C master wants to continually read the status register.
23-16	R/W	0	Slave Address: Bits [7:1] are used to identify the device. Bit [0] is ignored since this corresponds to the R/W bit.
15-8	R/W	0x27	HOLD TIME: Data hold time after the falling edge of SCL. This hold time is computed as Hold time = (MPEG system clock period) * (value + 1).
7	R/W	0	Enable: A '1' enables the I2C slave state machine.
6-0	R/W	0x06	Sampling rate. Defined as MPEG system clock / (value + 1). The SDA and SCL inputs into the slave module are sampled as a way of filtering the inputs. A rising or falling edge is determined by when 3 successive samples are either high or low respectively.

**Table 13-70 AO\_I2C\_S\_SEND\_REG: Send Data 0x1**

Bit(s)	R/W	Default	Description
31-0	R/W	0	The I2C slave module can send up to 4 bytes of data starting with the byte located at bits [7:0]

**Table 13-71 AO\_I2C\_S\_RECV\_REG: Received Data 0x2**

Bit(s)	R/W	Default	Description
31-0	R	0	This read only register corresponds to the 4 bytes of data written to the I2C slave module by an external I2C master. Bits [7:0] correspond to the first byte written by the I2C master.

**Table 13-72 AO\_I2C\_S\_CNTL1\_REG 0x3**

Bit(s)	R/W	Default	Description
31-6	R	0	Unused
5-3	R/W	0	SCL_FILTER: A filter was added in the SCL input path to allow for filtering of slow rise times. 0 = no filtering, 7 = max filtering
2-0	R/W	0x00	SDA_FILTER: A filter was added in the SDA input path to allow for filtering of slow rise times. 0 = no filtering, 7 = max filtering

## 13.5 Universal Asynchronous Receiver And Transmitter

### 13.5.1 Overview

There are a number of UARTs in the chip that offer 2-wire (RX/TX) and 4-wire (RX/TX, CTS/RTS) connections at the digital I/O pins. Each UART contains one transmit FIFO and a receive FIFO (see depths below). The FIFO's are filled by the CPU and read by the CPU. In some cases, the receive FIFO can be configured to be pushed directly to DDR memory without CPU intervention.

**Table 13-73 UART List**

UART	RX/TX FIFO depths	RX FIFO DMA to DDR	Comment
UART0	128 bytes	Yes	Located in the EE domain
UART1	64 bytes	Yes	Located in the EE domain
UART2	64 bytes	Yes	Located in the EE domain
UART0-AO	64 bytes	No	Located in the Always On domain
UART2-AO	64 bytes	No	Located in the Always On domain

### 13.5.2 Features

#### Input filters

The CTS (clear to send) and RX (receive) input paths have input filters to deal with slow rise times. The filters are configurable to use a 125ns or 1us sampling mechanism. There is an implied 3 system clock cycle delay (15ns for a typical system clock of 200MHz) that is used to synchronize and detect the rising/falling edge of the RXD signal. The RXD signal may be passed through an optional filter to deglitch the external signal in noisy conditions. The deglitch filter has two settings which add to the "detection delay" of the RXD signal by the internal logic:

- Filter setting 1 (125ns strobe): 375ns ~ 2.6us

- Filter setting 2 (1us strobe): 3us ~ 21us

The filter is described in the register specification. If the filter is disabled, the shortest RXD low time and high time is 12 system clock cycles (60ns for a system clock of 200MHz).

### Clear to Send

CTS is a signal sent from the receiver UART back to the transmitting UART to tell the transmitting UART to stop sending data. The CTS signal must be received before the next START symbol is sent. The transmitting UART is allowed to send one more byte after the CTS signal is recognized. The CTS signal coming into the chip goes through some synchronization and detection which adds an additional 5 system clocks (typically 25ns for a 200Mhz system clock). This setup time for CTS detection is called CTSstop. The CTS input also has an optional filter can be used to deglitch the incoming CTS signal. If the filter is disabled, the CTS signal must be de-asserted 5 system clock cycles before the start of the next BYTE transfer. If the CTS filter is enabled, then additional time must be added to the 25ns requirement. There are two programmable filter settings that effectively delay CTS being seen by the internal logic:

- Filter setting 1 (125ns strobe): 375ns ~ 2.6us
- Filter setting 2 (1us strobe): 3us ~ 21us

### Interrupts

The UARTs can generate interrupts if the receive FIFO exceeds a pre-programmed threshold. An interrupt can also be generated if there is a frame or parity error.

### Clock Independent Operation

Because the system clock can be altered to accommodate dynamic frequency scaling, the UARTs have an option in which they use the 24Mhz crystal clock as the source for the UART.

## 13.5.3 Functional Description

The UART requires that a Baud Rate be established. The UART supports rates as slow as 1Hz up to rates as high as 8M bits/s. Once the baud rate has been established, bytes are transmitted as they are written to the transmit-FIFO by the CPU. A large transmit-FIFO exists to allow the CPU to pre-load a transmit package because the CPU can often write faster than the UART can transmit the data.

Data this automatically received by the UART is placed into the receive FIFO one byte at a time. The receive-FIFO decouples the UART from the CPU allowing the CPU to read the UART byte data at a rate not dictated by the UART.

## 13.5.4 Register Description

The following register description is uniformly applied to all UART instantiations in the chip.

Base\_adr:0xffd00000

Final\_adr = base\_adr + offset \*4

UART0 = 128x8 FIFOs

UART1 = 64x8 FIFOs

UART2 = 64x8 FIFOs

**Table 13-74 UARTx\_WFIFO: Write data 0x9000**

Bit(s)	R/W	Default	Description
31-8	R	0	unused
7-0	R/W	-	Write FIFO data. The Write FIFO holds 128 or 64 bytes. The Write FIFO can be written as long as it is not full.

**Table 13-75 UARTx\_RFIFO: Read Data 0x9001**

Bit(s)	R/W	Default	Description
31-8	R	0	unused
7-0	R/W	-	Read FIFO data. The Read FIFO holds 128 or 64 bytes. The empty flag can be used to determine if data is available

**Table 13-76 UARTx\_CONTROL: UART Mode 0x9002**

Bit(s)	R/W	Default	Description
31	R/W	0	Invert the RTS signal
30	R/W	0	Mask Error: Set to 1 to mask errors
29	R/W	0	Invert the CTS signal
28	R/W	0	Transmit byte Interrupt: Set to 1 to enable the generation an interrupt whenever a byte is read from the transmit FIFO
27	R/W	0	Receive byte Interrupt: Set to 1 to enable the generation an interrupt whenever a byte is written to the receive FIFO
26	R/W	0	Set to 1 to invert the TX pin
25	R/W	0	Set to 1 to invert the RX pin
24	R/W	0	Clear Error
23	R/W	0	Reset the receive state machine
22	R/W	0	Reset the transmit state machine
21-20	R/W	0	Character length: 00 = 8 Bits, 01 = 7 Bits, 10 = 6 Bits, 11 = 5 Bits
19	R/W	1	Parity Enable: Set to 1 to enable parity
18	R/W	0	Parity type: 0 = even, 1 = odd
17-16	R/W	0	Stop bit length: 00 = 1 bit, 01 = 2 Bits
15	R/W	0	Two Wire mode:
14	R/W	0	Unused
13	R/W	0	Receive Enable. Set to 1 to enable the UART receive function
12	R/W	0	Transmit Enable. Set to 1 to enable the UART transmit function
11-0	R/W	0x120	Old Baud rate

**Table 13-77 UARTx\_STATUS: UART Status 0x9003**

Bit(s)	R/W	Default	Description
31-27	R	0	Unused
26	R	0	UART_RECV_BUSY: This bit will be 1 if the uart receive state machine is busy
25	R	0	UART_XMIT_BUSY: This bit will be 1 if the uart transmit state machine is busy
24	R	0	RECV_FIFO_OVERFLOW:
23	R	0	CTS Level

Bit(s)	R/W	Default	Description
22	R	0	Transmit FIFO Empty
21	R	0	Transmit FIFO Full
20	R	0	Receive FIFO empty
19	R	0	Receive FIFO full
18	R	0	This bit is set if the FIFO is written when it is full. To clear This bit, write bit 24 of register 0x2132
17	R	0	Frame error. To clear This bit, write bit 24 of register UART0_CONTROL
16	R	0	Parity error. To clear This bit, write bit 24 of register UART0_CONTROL
15	R	0	Unused
14-8	R	0	Transmit FIFO count. Number of bytes in the transmit FIFO
7	R	0	Unused
6-0	R	0	Receive FIFO count. Number of bytes in the receive FIFO

**Table 13-78 UARTx\_MISC: UART IRQ CONTROL 0x9004**

Bit(s)	R/W	Default	Description
31	R/W	0	Added a "just in case" bit that can be set to 1 to enable clocks always. The default is 0 meaning the auto-clock gating logic is enabled.
30	R/W	0	USE old Rx Baud: There was a bug in the RX baud rate generator. The Rx baud rate generator was re-designed to compute a baud rate correctly. If you want to use the old (stupid) logic, you can set This bit to 1.
29	R/W	0	ASYNC_FIFO_PURGE: This bit can be set to 1 after all UART bytes have been received in order to purge the data into the Async FIFO. This bit is needed because the UART receives 8-bit data, but the ASYNC FIFO can only be written with 16-bit data. In this case there might be a residual byte if the UART is not receiving an even number of bytes.
28	R/W	0	ASYNC_FIFO_EN: If This bit is set to 1, then the UART received data is automatically sent to the Async FIFO module which will in turn automatically send the data to DDR memory
27	R/W	0	CTS: Filter Timebase select: 1 = 1uS, 0 = 111nS timebase. A filter was added to the CTS input to allow for a little digital filtering. The amount of filtering is controlled by this timebase (longer = more filtering) and the value in Bits FILTER_SEL below.
26-24	R/W	0	CTS: FILTER_SEL: 0 = no filter, 7 = max filtering
23-20	R/W	0	old BAUD_RATE_EXT: These 4 Bits extend the baud rate divider to 16-bits: Baud Rate = {Reg4[23:20],Reg2[11:0]}
19	R/W	0	RX: Filter Timebase select: 1 = 1uS, 0 = 111nS timebase. A filter was added to the RX input to allow for a little digital filtering. The amount of filtering is controlled by this timebase (longer = more filtering) and the value in Bits FILTER_SEL below.
18-16	R/W	0	RX: FILTER_SEL: 0 = no filter, 7 = max filtering
15-8	R/W	32	XMIT_IRQ_CNT: The UART can be configured to generate an interrupt if the number of bytes in the transmit FIFO drops below this value.
7:0	R/W	15	RECV_IRQ_CNT: The UART can be configured to generate an interrupt after a certain number of bytes have been received by the UART.



**Table 13-79 UARTx\_REG5 0x9005**

Bit(s)	R/W	Default	Description
31-28	R/W	0	unused
27	R/W	0	Xtal2_clk_sel: 0: see Xtal_clk_sel 1: xtal_div2(12M)
26	R/W	0	Xtal_clk_sel: 0: xtal_div3(8M); 1: xtal(24M);(need set xtal_tick_en =1 first);
24	R/W	0	USE_XTAL_CLK: If this bit is set, then the clock for generating the UART Baud rate comes from the crystal pad. This allows the UART to operate independent of clk81.
23	R/W	0	USE New Baud rate. Over the years, the baud rate has been extended by concatenating bits from different registers. To take advantage of the full 23-bit baud rate generate (extended to 23 bits to accommodate very low baud rates), you must set this bit. If this bit is set, then the baud rate is configured using bits [22:0] below
22:0	R/W	15	NEW_BAUD_RATE: If bit[23] = 1 above, then the baud rate for the UART is computed using these bits. This was added in M6 to accommodate lower baud rates.

UART1\_WFIFO: Write data 0x8c00

See UART0 bit descriptions

UART1\_RFIFO: Read Data 0x8c01

See UART0 bit descriptions

UART1\_CONTROL: UART Mode 0x8c02

See UART0 bit descriptions

UART1\_STATUS: UART Status 0x8c03

See UART0 bit descriptions

UART1\_MISC: UART IRQ CONTROL 0x8c04

See UART0 bit descriptions

UART1\_REG5 0x8c05

See UART0 bit descriptions

UART2\_YFIFO: write data 0x8800

See UART0 bit descriptions

UART2\_RFIFO: Read Data 0x8801

See UART0 bit descriptions

UART2\_CONTROL: UART Mode 0x8802

See UART0 bit descriptions

UART2\_STATUS: UART Status 0x8803

See UART0 bit descriptions

UART2\_MISC: UART IRQ CONTROL 0x8804

See UART0 bit descriptions

UART2\_REG5 0x8805

See UART0 bit descriptions

UART3\_DF\_REG\_A73 0x8400

See UART3\_SLIP bit descriptions

UART3\_DF\_REG\_A74 0x8401

See UART3\_SLIP bit descriptions

UART3\_DF\_REG\_A75 0x8402

See UART3\_SLIP bit descriptions

UART3\_DF\_REG\_A76 0x8403

See UART3\_SLIP bit descriptions

UART3\_DF\_REG\_A77 0x8404

See UART3\_SLIP bit descriptions

UART3\_DF\_REG\_A78 0x8405

See UART3\_SLIP bit descriptions

UART3\_DF\_REG\_A79 0x8406

See UART3\_SLIP bit descriptions

UART3\_DF\_REG\_A80 0x8407

See UART3\_SLIP bit descriptions

UART3\_DF\_REG\_A81 0x8408

See UART3\_SLIP bit descriptions

UART3\_DF\_REG\_A82 0x8409

See UART3\_SLIP bit descriptions

UART3\_DF\_REG\_A83 0x8410

See UART3\_SLIP bit descriptions

UART3\_DF\_REG\_A84 0x8411

See UART3\_SLIP bit descriptions

UART3\_DF\_REG\_A85 0x8412

See UART3\_SLIP bit descriptions

UART3\_DF\_REG\_A86 0x8413

See UART3\_SLIP bit descriptions

UART3\_DF\_REG\_A87 0x8414

See UART3\_SLIP bit descriptions

UART3\_DF\_REG\_A88 0x8415

See UART3\_SLIP bit descriptions

UART3\_DF\_REG\_A89 0x8416

See UART3\_SLIP bit descriptions

UART3\_DF\_REG\_A96 0x8417

See UART3\_SLIP bit descriptions

UART3\_DF\_REG\_A97 0x8418

See UART3\_SLIP bit descriptions

UART3\_DF\_REG\_A128 0x8420

See UART3\_SLIP bit descriptions

UART3\_DF\_REG\_A129 0x8421

See UART3\_SLIP bit descriptions

UART3\_DF\_REG\_A130 0x8422

See UART3\_SLIP bit descriptions

UART3\_DF\_REG\_A131 0x8423

See UART3\_SLIP bit descriptions

UART3\_DF\_REG\_A132 0x8424

See UART3\_SLIP bit descriptions

UART3\_DF\_REG\_A133 0x8425

See UART3\_SLIP bit descriptions

UART3\_DF\_REG\_A134 0x8426

See UART3\_SLIP bit descriptions

UART3\_DF\_REG\_A135 0x8427

See UART3\_SLIP bit descriptions

UART3\_DF\_REG\_A136 0x8428

See UART3\_SLIP bit descriptions

## 13.6 Infrared Remote

### 13.6.1 Overview

IR module includes 3 sub modules: IR demodulation, Legacy IR remote control and Multi-format IR remote control.

### 13.6.2 IR Demodulation

IR demodulation module demodulate the modulate signal to get the envelop signal.

IR demodulation diagram is shown below.

Figure 13-1 IR Demulation

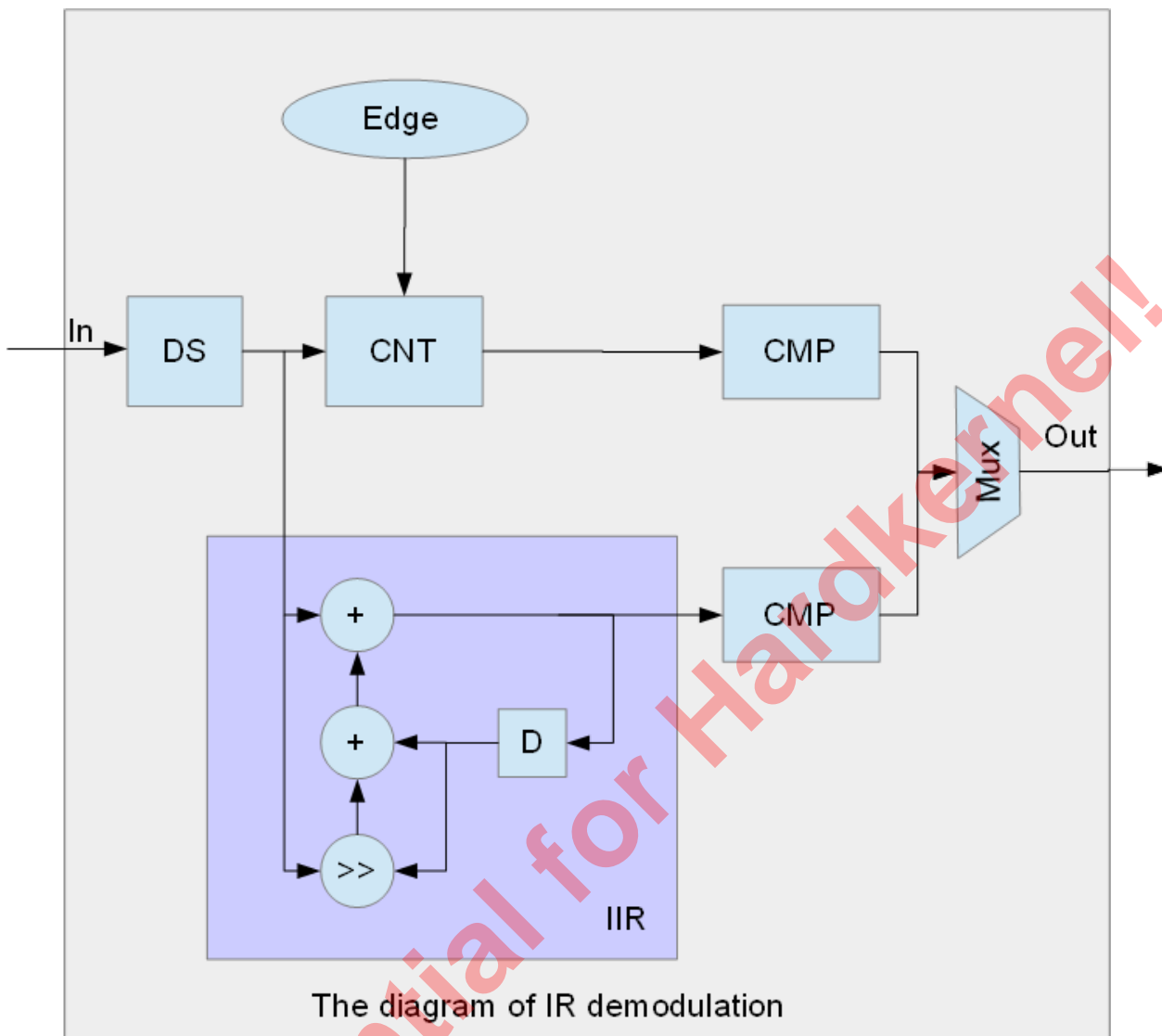

It implements two methods for demodulation. The input data is an one-bit stream.

The input data are down-sampled firstly. The rate of downsample are configured by register, ranges from 0 to 255.

One method is implemented in the upper path.

The CNT is used to counte the time for '0' and '1'. It is cleared when input data changes (from 1 to 0 or from 0 to 1).

When  $(CNT > REG\_IR\_PROCT1 \ \&\& \ in == 1)$ , it outputs '1'. REG\_IR\_PROCT1 is used to canceled the glitch. Actually, the operation of downsample also have some utility to cancel the glitch.

When  $(CNT > REG\_IR\_DECT0 \ \&\& \ in == 0)$ , it outputs '0'. REG\_IR\_DECT0 is used to confirm the '0'. The value should be bigger than one carrier period.

The other method is implemented in the lower path.

It is a one tap IIR filter. The input data control the integrating factor and the factor can be configured from registers. When 1 inputs, the accumulator can grow quickly. When 0 input, the accumulator decays slowly, and when the number of 0 is bigger enough, it decays soon.

When  $(accum > REG\_IR\_IIR\_THD1)$ , it outputs '1'.

When ( $\text{accum} < \text{REG\_IR\_IIR\_THD0}$ ), it outputs '0'.

The diagram shows the simple simulation result. The blue is the input data, the red is the filter out.

**Figure 13-2 Simulation Result of IR Demulation**

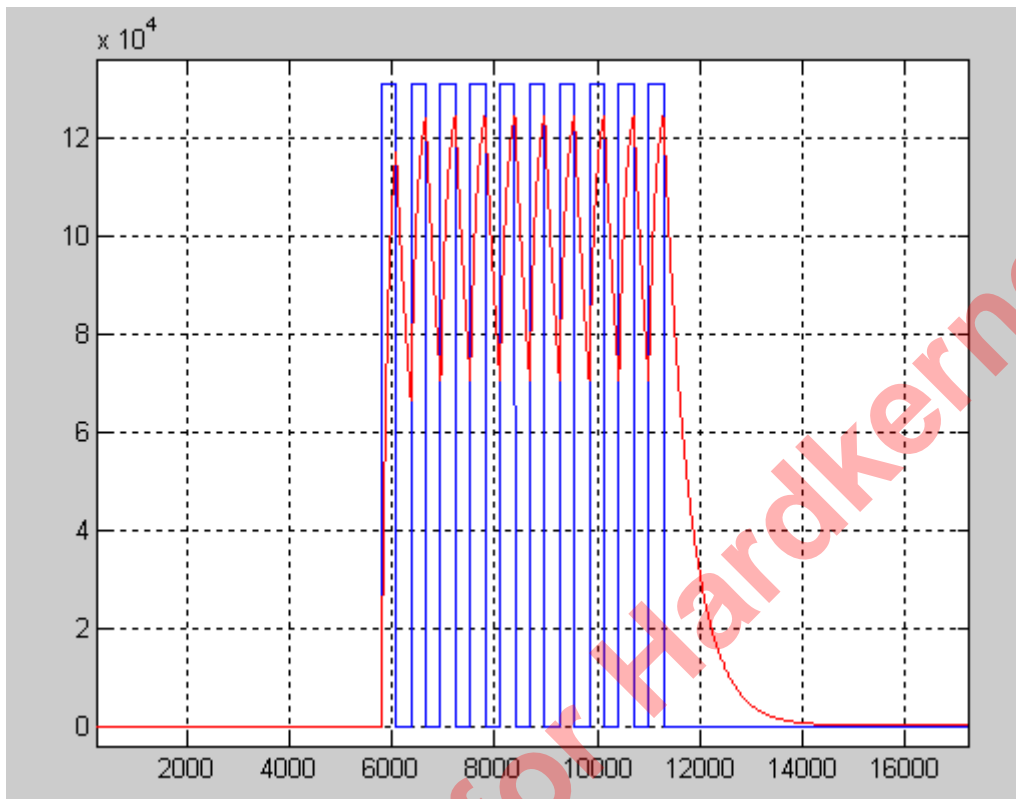

Because the input carrier signal is a rectangular wave signal, the carrier can be estimated easily by counting the wave period. For estimating precisely, the counter for the long "0" and start period and glitch should be removed.

The simple diagram is shown below:

Figure 13-3 IR Carrier Discovery

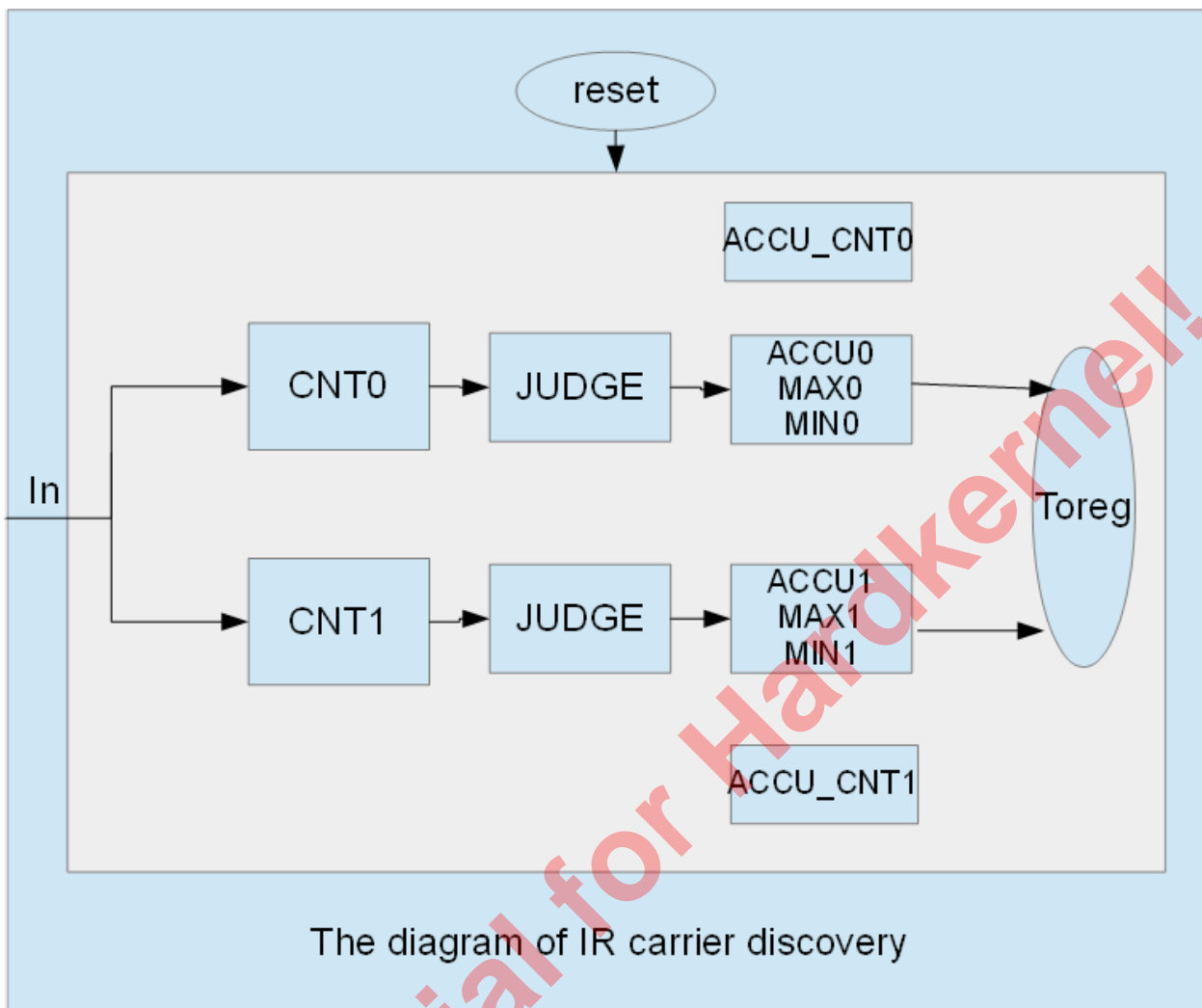

CNT is the counter for time of “0” and “1”.

JUDGE is used to remove the long “0” and glitch.

ACCU\_CNT is the counter for number of accumulating. If  $ACCU\_CNT == REG\_IR\_ST\_CNT\_THD$ , then write the value to registers.

For example:

Set  $REG\_IR\_ST\_CNT\_THD$  to 256, then accumulates 256 times.

The carrier can be calculated:

$$F_c = F_{sys} / (RO\_IR\_SUM\_CNT0 + RO\_IR\_SUM\_CNT1) * 256;$$

$$DUT = RO\_IR\_SUM\_CNT1 / (RO\_IR\_SUM\_CNT0 + RO\_IR\_SUM\_CNT1);$$

Where  $F_c$  is the carrier frequency,  $F_{sys}$  is the system clock frequency, DUT is the carrier duty ratio.

### 13.6.3 Legacy IR Control

The Legacy IR Remote control module has two modes of operation:

- NEC Frame decoder mode
- General Time Measurement mode

**Note**

NEC Frame Decoder: The NEC Frame Decoder mode operates by analyzing the waveform of a TV remote.

**Figure 13-4 NEC Frame Decoder**

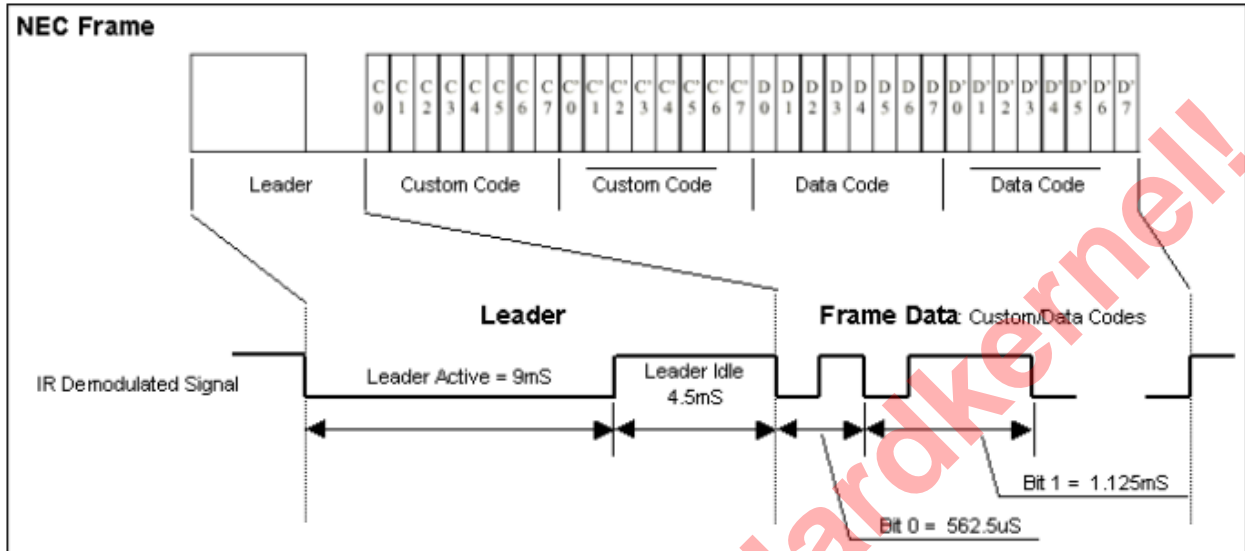

The waveform has a number of components, each of which must fit within a time window to be considered valid. If the entire waveform meets the specifications described by the registers below, then the TV remote codes are captured and an interrupt is generated.

**Note**

General Time Measurement: Some remotes don't follow the standard NEC format, so additional registers provide the ability to measure the time between rising and/or falling edges of the IR signal. Since the time measurement is done in hardware, the software only needs to read a "width" measurement from a register for every rising and/or falling edge event.

### 13.6.4 Multi Format IR Control

The decoder mainly consisted of two blocks:

- Decoder with input filter
- A set of registers including control & clock, data and tuning

The function diagram of IR decoder is illustrated in the figure below.

Figure 13-5 IR Decoder Function Block

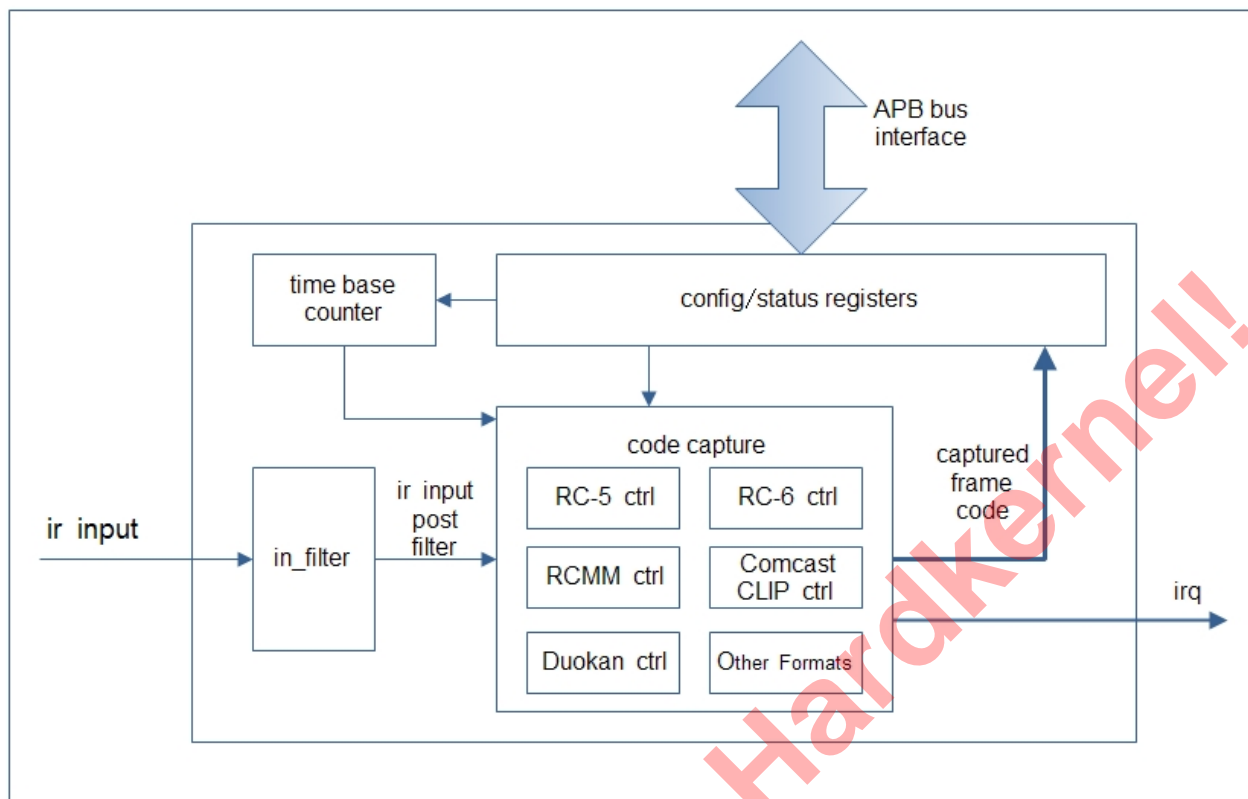

IR Decoder decodes the IR remote control input signal. 13 operation modes are supported:

- Hardware Decode IR transmission protocol compatible frame decoder mode ( NEC MITSUBISHI Thomson Toshiba Sony SIRC RC5 RC6 RCMM Duokan Comcast Sanyo Modes)
- General programmable time measurement frame decoder mode (General Mode)

In Hardware Decode Mode, the Decoder uses signal pattern search mechanism to decode data frame. It can detect logical "0", "1", "00", "01", "10" and "11", as well as data frame start and end. Whenever Decoder detects and decodes the data frame, the data are kept in data register.

In General Mode, the Decoder uses edge detection mechanism to decode data frame. It can detect each input signal edge and record the time between two edges. The time measurement result is kept in control register.

The user should set proper operation mode corresponding to the selection of remote controller.

There is a simple time-based signal Filter between the signal input and the Decoder. The Filter is programmable and helps to improve signal integrity.

### 13.6.5 Register Description

For the following registers:

Base\_adr: 0xFF800000

Final\_adr = base\_adr + offset \*4



**Table 13-80 AO\_IR\_BLAster\_ADDR0 0x53**

Bit(s)	R/W	Default	Description
31-27	R	0	unused
26	R	-	BUSY: If this bit is 1, then the IR Blaster module is busy.
25	R	-	This output is 1 when the FIFO is Full
24	R	-	This output is 1 when the FIFO is Empty
23-16	R	-	FIFO Level
15-14	R/W	0	Unused
13-12	R/W	0	MODULATOR_TB: This input controls the clock used to create the modulator output. The modulator is typically run between 32khz and 56khz. The modulator output will equal a divided value of the following: 00: system clock "clk" 01: mpeg_xtal3_tick 10: mpeg_1uS_tick 11: mpeg_10uS_tick
11-4	R/W	0	SLOW_CLOCK_DIV: This is a divider value used to divide down the input "clk". The divider is N+1 so a value of 0 equals divide by 1.
3	R/W	0	SLOW_CLOCK_MODE: Set this signal high to use a special mode in which the "clk" input is driven by a slow clock less than 1Mhz. This is used for low power cases where we want to run the IR Blaster between 32khz and 1Mhz
2	R/W	0	INIT_LOW: Setting this bit to 1 initializes the output to be high. Please set this bit back to 0 when done
1	R/W	0	INIT_LOW: Setting this bit to 1 initializes the output to be low. Please set this bit back to 0 when done
0	R/W	0	ENABLE: 1 = Enable. If this bit is set to 0, then the IR blaster module is reset and put into an IDLE state.

**Table 13-81 AO\_IR\_BLAster\_ADDR1 0x54**

Bit(s)	R/W	Default	Description
31-28	R/W	0	unused
27-16	R/W	0	This value is used with "modulator_tb[1:0]" above to create a low pulse. The time is computed as (mod_lo_count+1) x modulator_tb. The purpose for having a low/high count is the modulator output might not be 50% duty cycle. Hi/Lo counters allow us to modulate using a non-50% duty cycle waveform.
15-12	R/W	0	Unused
11-0	R/W	0	This value is used with "modulator_tb[1:0]" above to create a high pulse. The time is computed as (mod_hi_count+1) x modulator_tb

**Table 13-82 AO\_IR\_BLAster\_ADDR2 0x55**

Bit(s)	R/W	Default	Description
31-17	R	0	unused
16	W	0	Set this bit to 1 to write the data below to the FIFO

Bit(s)	R/W	Default	Description
15-12	R	0	Unused
11-0	R/W	0	FIFO data to be written: Bit[12] output level (or modulation enable/disable: 1 = enable) Bit[11:10] Timebase: 00 = 1uS 01 = 10uS 10 = 100uS 11 = Modulator clock Bit[9:0] Count of timebase units to delay

Table 13-83 AO\_IR\_BLASTER\_ADDR3 0x56

Bit(s)	R/W	Default	Description
31-17	R	0	unused
16	R	0	fifo thd pending
8	R/W	0	FIFO irq enable
7:0	R/W	0	FIFO irq threshold.

For the following registers:

Base\_adr: 0xff808000

Final\_adr = base\_adr + offset \*4

Table 13-84 AO\_IR\_DEC\_DEMOD\_CNTL0 0x30

Bits	R/W	Default	Description
31			Ir demodulator soft_reset:write 1 to reset ir_demodulator,will auto clr to 0
30			Reg_ir_fd_reset :It is used to reset the carrier detection module.write 1 to reset , will auto clr to 0
29			Reg_ir_demod_mode:It is uset to set the demod mode. 0 = count mode; 1 = iir mode.default is 0
28			Ir demodulator clk gate bypass:write 1 will bypass clk gate,default is 0
27:16			Reg_ir_st_cnt_thd:It is used to set the statistics number for carrier detection.default is 0x40
15:8			Reg_ir_ds_rate:It is uset to set the downsample rate.default is 0x8
7:4			Reg_ir_fsft_1:It is used to set the shift value for input data "1".default is 0x7
3:0			Reg_ir_fsft_0:It is used to set the shift value for input data "0".default is 0x9

Table 13-85 AO\_IR\_DEC\_DEMOD\_CNTL1 0x31

Bits	R/W	Default	Description
31			Reg_ir_demod_en:ir demod enable ,default is 0
30			Reg_ir_inv:ir input invert, invert input at 1.default is 0

Bits	R/W	Default	Description
29:16			Reg_ir_proctect1:It is used to set the protection threshold for 1. It is used to filter the glitch.default is 0xa
13:0			Reg_ir_detect0:It is used to set the detection threshold for signal "0".default is 0x3e8

Table 13-86 AO\_IR\_DEC\_DEMOD\_IIR\_THD 0x32

Bits	R/W	Default	Description
31:16			Reg_ir_iir_thd1:It is used to set the detection threshold for "1" in iir mode.default is 0xdac
15:0			Reg_ir_iir_thd0:It is used to set the detection threshold for "0" in iir mode.default is 0xdac

Table 13-87 AO\_IR\_DEC\_DEMOD\_THD0 0x33

Bits	R/W	Default	Description
29:16			Reg_ir_thd0_low:It is used to set the low threshold for "0" when statistics.default is 0x12c
13:0			Reg_ir_thd0_high:It is used to set the high threshold for "0" when statistics.default is 0x1770

Table 13-88 AO\_IR\_DEC\_DEMOD\_THD1 0x34

Bits	R/W	Default	Description
29:16			Reg_ir_thd1_low:It is used to set the low threshold for "1" when statistics.default is 0x12c
13:0			Reg_ir_thd1_high:It is used to set the high threshold for "1" when statistics.default is 0x1770

Table 13-89 AO\_IR\_DEC\_DEMOD\_SUM\_CNT0 0x35

Bits	R/W	Default	Description
25:0			Ro_ir_sum_cnt0:It is used to report the sum value for the statistics data "0". READ ONLY

Table 13-90 AO\_IR\_DEC\_DEMOD\_SUM\_CNT1 0x36

Bits	R/W	Default	Description
25:0			Ro_ir_sum_cnt1:It is used to report the sum value for the statistics data "1". READ ONLY

**Table 13-91 AO\_IR\_DEC\_DEMOD\_CNT0 0x37**

Bits	R/W	Default	Description
29:16			Ro_ir_max_cnt0:It is used to report the maximum value for the statistics data "0". READ ONLY
13:0			Ro_ir_min_cnt0:It is used to report the minimum value for the statistics data "0". READ ONLY

**Table 13-92 AO\_IR\_DEC\_DEMOD\_CNT1 0x38**

Bits	R/W	Default	Description
29:16			Ro_ir_max_cnt1:It is used to report the maximum value for the statistics data "1". READ ONLY
13:0			Ro_ir_min_cnt1:It is used to report the minimum value for the statistics data "1". READ ONLY

**Table 13-93 AO\_IR\_DEC\_LDR\_ACTIVE: Leader Active Time 0x00**

Bit(s)	R/W	Default	Description
31-29	R	0	unused
28-16	R/W	0x 1d8	Max Leader ACTIVE time: 9.44mS assuming base rate = 20uS
15-13	R	0	unused
12-0	R/W	0x1ac	Min Leader ACTIVE time: 8.56mS assuming base rate = 20uS

This register controls the min/max leader active time window. For most TV remote controls, the leader active time is about 9mS. The values in this register correspond to counts of the base rate programmed by register 0x2124

**Table 13-94 AO\_IR\_DEC\_LDR\_IDLE: Leader Idle Time 0x01**

Bit(s)	R/W	Default	Description
31-26	R	0	unused
28-16	R/W	0xf8	Max Leader IDLE time: 4.96mS assuming base rate = 20uS
15-13	R	0	unused
12-0	R/W	0xca	Min Leader IDLE time: 4.04mS assuming base rate = 20uS

This register controls the min/max leader IDLE time window. For most TV remote controls, the leader idle time is about 4.5mS. The values in this register correspond to counts of the base rate programmed by register: 0x2124

**Table 13-95 AO\_IR\_DEC\_LDR\_REPEAT: Repeat Leader Idle Time 0x02**

Bit(s)	R/W	Default	Description
31-26	R	0	Unused
25-16	R/W	0x7a	Max REPEAT Leader IDLE time: 2.44mS assuming base rate = 20uS
15-10	R	0	unused
9-0	R/W	0x66	Min REPEAT Leader IDLE time: 2.04mS assuming base rate = 20uS

This register controls the repeat leader IDLE time window. The repeat key uses the standard leader active time (9ms) but a shorter leader idle time.

**Table 13-96 AO\_IR\_DEC\_BIT\_0: BIT 0 Identification Time 0x03**

Bit(s)	R/W	Default	Description
31-26	R	0	Unused
25-16	R/W	0x42	Max BIT 0 time: 1.32mS assuming base rate = 20uS
15-10	R	0	Unused
9-0	R/W	0x2e	Min BIT 0 time: 0.92mS assuming base rate = 20uS

This register controls the min/max BIT 0 time window. For most TV remote controls, the bit 0 time is about 1.125mS. The values in this register correspond to counts of the base rate programmed by register: 0x2124

**Table 13-97 AO\_IR\_DEC\_REG0: Base Rate Generator 0x04**

Bit(s)	R/W	Default	Description
31	R	0	Just in case bit. Normally this bit is set to 0 so that the auto-clock gating is enabled. If there is a problem related to the auto-clock gating, then this bit can be set to one to disable the auto-clock gating.
30-28	R/W	0	FILTER_COUNT: This is a new feature to Nike. The IR remote input now has a simple filter that accommodates slow rise times by providing a little hysteresis. The logic works as follows. If the input is low, then an input signal will only be considered HIGH if it remains high for (FILTER_COUNT * 111nS). Similarly, if the input is currently high, it will only be considered LOW if the input signal remains low for (FILTER_COUNT * 111nS).
27-25	R	0	Unused
24-12	R/w	0xFA0	Max Frame Time. 80mS assuming base rate = 20uS This value is used to determine if a code is a repeat code (e.g. leader followed by no data for this amount of time). This value can also be used to catch slow remote codes (i.e. code sequences that are longer than expected).
11-0	R/W	0x13	This value dictates the base rate time for all measurements associated with the IR decoder. In the past, the base rate was divided from the system clock. In the current design, the base rate is divided from a fixed 1uS timer. This 1uS timer is constant and doesn't change (even when the system clock does) Base rate = (count + 1) * 1uS

This register controls the master rate generator for all width measurements made by the IR decoder module.

**Table 13-98 AO\_IR\_DEC\_FRAME: Frame Data 0x05**

Bit(s)	R/W	Default	Description
31-0	R	0	Frame Data. Format: {custom code, ~custom code, data, ~data}

#### Note

New keys will be ignored until this register is read if the hold first key bit is set in the decode control register. Reading this register resets an internal hold first flag.

Table 13-99 AO\_IR\_DEC\_STATUS: Frame Status 0x06

Bit(s)	R/W	Default	Description
31	R/W	0	Sim faster: Reserved
30	R/W	0	BIT_1_MATCH_EN: Set this bit to 1 to enable qualification of bit 1 times. In the previous IR decoder module, frame detection only looked at the BIT 0 time to identify a zero bit. If a zero bit time wasn't found, then it was assumed that the bit was a 1. In the updated IR decoder module, the module will look at the BIT 0 time to find zero bits, and the BIT 1 time to find 1 bits. If the width of a pulse doesn't match the zero or the one bit width time, then the frame is considered invalid.
29-20	R/W	0x89	Max BIT 1 time: 2.74mS assuming base rate = 20uS
19-10	R/W	0x57	Min BIT 1 time: 1.74mS assuming base rate = 20uS
9	R	-	IRQ Status. 1 if there is an interrupt
8	R	-	IR Decoder input. This is the level of the digital signal coming into the IR module for decoding. This is the same as reading the I/O pad level.
7	R	-	BUSY. 1 if the decoder is busy
6-4	R	0	Decoder Status: For debug only 000: OK 001: last frame timed out 010: leader time error (invalid IR signal) 011: repeat error (repeat leader, but other IR transitions found). 100: Invalid bit
3-0	R	0	Frame Status Bit 3: Frame data valid Bit 2: data code error (data != ~data in IR bit stream) Bit 1: custom code error (custom_code != ~custom_code in IR bit stream) Bit 0: 1 = repeat key, 0 = standard key

Table 13-100 AO\_IR\_DEC\_REG1: Decode / Interrupt Control 0x07

Bit(s)	R/W	Default	Description
31	R	0	Unused
30	R/W	0	CNTL_1uS_EQ_CLK: This bit should be set to 1 if the clk81 (system clock) is less than 50 Mhz.
29	R/W	0	CNTL_111nS_EQ_CLK: This bit should be set to 1 if the clk81 (system clock) is less than 50 Mhz.
28-16	R	0	Time measurement since the last time the internal time counter was reset by the rising and/or falling edge of the IR signal. The selection of reset on rising and/or falling edge is determined by the selection of the IRQ (Bits 3-2 below)
15	R/W	1	ENABLE: If this bit is 1, then the state-machines are enabled. If this bit is zero, then the state-machines cleanup and immediately return to idle.
14	R/W	0	USE_SYSTEM_CLOCK: This is a new feature. 1 = use the system clock, 0 = use the 1uS timebase tick. During normal operation, the module is setup to create a 20uS tick from the 1uS internal timebase of the chip. If the chip is configured to operate using the 32khz RTC oscillator, the 1uS timebase is invalid and therefore the 20uS timebase is invalid. In order to measure time correctly, the IR remote circuit can use the system clock (which in this case is the 32khz oscillator clock) as the master timebase.
13-9	R/W	1f	Number of bits in the IR frame (N-1)
8-7	R/W	0	Decoder mode 00: NEC Frames: Decode Leader and 32 bits 01: Only accumulate bits (skip the leader)

Bit(s)	R/W	Default	Description
			10: Measure Mode: The internal width measuring counter is reset on the rising and/or falling edge of the IR remote signal based on the settings of IRQ Selection below. Just before being reset, the measured width is captured and stored so that it can be read in bits [28:16] of this register. 11: NEC Frames: Decode Leader and 32 bits
6	R/W	1	Hold First Key. If this bit is set true, then the frame data register (0x2125) will only be updated if hasn't already been updated. Once updated, the frame data register will not be updated again until it has been read. This bit can be used to guarantee the first TV remote code captured will not be overwritten by subsequent transmissions from a TV remote. NOTE: You must read the frame data register to clear an internal hold first flag if this bit is set.
5-4	R/W	11	Frame mask. These bits are used to qualify frames for capture. 00: Capture all frames good or bad 01: Capture only frames where data=~data. Ignore custom codes 10: Capture only frames where custom_code = ~custom_code. Ignore data codes 11: Capture only frames where (data=~data) and (custom_code = ~custom_code)
3-2	R/W	0	IRQ Selection and width measurement reset: 00: IR Decoder done 01: IR input rising or falling edge detected 10: IR input falling edge detected 11: IR rising edge detected
1	R/W	0	IR Polarity. Polarity of the input signal (VD[0])
0	R/W	0	Set to 1 to reset the IR decoder. This is useful because the IR remote state machine thinks in terms of milliseconds and may take tens of milliseconds to return to idle by itself.

**AO\_MF\_IR\_DEC\_LDR\_ACTIVE: Leader Active control 0x10** This register controls the min/max Leader Active time window. For example, for NEC format, the Leader Active time is about 9mS. To identify a Leader Active time between 8.60 mS and 9.40 mS (assuming base resolution = 20uS), user can set Max duration = 0x1d6 ('d470) to represent 9.40 mS, and set Min duration = 0x1ae ('d430) to represent 8.60 mS.

Bit(s)	R/W	Default	Description
31-29	R	0	Unused
28-16	R/W	0	Max duration of Leader's active part
15-13	R	0	Unused
12-0	R/W	0	Min duration of Leader's active part

**Table 13-101 AO\_MF\_IR\_DEC\_LDR\_IDLE: Leader Idle control 0x11**

Bit(s)	R/W	Default	Description
31-29	R	0	Unused
28-16	R/W	0	Max duration of Leader's idle part
15-13	R	0	Unused
12-0	R/W	0	Min duration of Leader's idle part

**Table 13-102 AO\_MF\_IR\_DEC\_LDR\_REPEAT: Repeat Leader Idle Time 0x12**

Bit(s)	R/W	Default	Description
31-26	R	0	Unused
25-16	R/W	0	Max duration of Repeat Code's Leader. In NECformat, it defines for the repeat leader's idle part. In Toshiba format, it defines for the repeat leader's second idle part (In Toshiba format, the repeat leader's first idle part has the same duration time as the normal leader idle part.)
15-10	R	0	Unused
9-0	R/W	0	Min duration of Repeat Code's Leader

**Table 13-103 AO\_MF\_IR\_DEC\_BIT\_0 0x13**

Bit(s)	R/W	Default	Description
31-26	R	0	Unused
25-16	R/W	0	Max duration of Duration Setting Register 0. It defines max timing duration for: Logic"0" for NEC/Toshiba/Sony/Thomas format or Half trailer bit for RC6 format (RC6's half trailer bit typically 888.89us) or time of Duokan/RCMM/4ppm format's Logic "00"
15-10	R	0	Unused
9-0	R/W	0	Min duration of Duration Setting Register 0.

**Table 13-104 AO\_MF\_IR\_DEC\_REG0 0x14**

Bit(s)	R/W	Default	Description
31	R/W	0	Clock gating control just in case. Set 1 can force clock gating disabled.
30-28	R/W	0	Filter ctrl. Set the monitor timing for input filter, bigger value means longer monitor time. Value 0 = no filtering.
27-25	R	0	Unused
24-12	R/W	0	Max frame time. Max duration of one whole frame.
11-0	R/W	0	Base time parameter. Used to generate the timing resolution. Resolution = (base_time_paramter + 1) * (1/ Freq_sys_clk). For example, if Frequency of sys_clk is 1Mhz, and base_time_parameter=19, Then resolution = (19+1)*(1uS) = 20uS.



Table 13-105 AO\_MF\_IR\_DEC\_STATUS 0x16

Bit(s)	R/W	Default	Description
31	R/W	0	Frame data valid 1. (This bit is set to 1 when a captured frame is updated/stored into "FrameBody_1" register. A read of "FrameBody_1" register will clear This bit. "FrameBody_1" register is used to store the over 32bit MSBs of the formats whose length is more than 32 bit )
30	R/W	0	bit_1_match_en. Set to 1 to enable the check of whether logic"1" bit matches timing configure during the frame input process.
29-20	R/W	0	Max Duration 1. Max duration of Duration Setting Register 1. It defines max duration for: Logic"1" for NEC/Toshiba/Sony format or Whole trailer bit for RC6 format (RC6's whole trailer bit typically 1777.78us) or time of Duokan/RCMM/4ppm format's Logic "01"
19-10	R/W	0	Min Duration 1. Min duration of Duration Setting Register 1.
9	R	0	irq_status. Appear as 1 if there is an interrupt.
8	R	0	ir_i_sync. IR remote serial input after synchronization. This is the level of the digital signal coming into the IR module for decoding. This is the same as reading the I/O pad level.
7	R	0	Busy. When =1, means state machine is active.
6-4	R	0	Decoder_status ( for debug only ). 000: OK 001: last frame timed out 010: leader time error (invalid IR signal) 011: repeat error (repeat leader, but other IR transitions found). 100: Invalid bit
3-0	R	0	Frame status. bit 3: Frame data valid (This bit is set to 1 when a captured frame is updated/stored into "FrameBody" register. A read of "FrameBody" register will clear This bit. If store and read occurs at the same time, This bit is set to 1 in common, But if "Hold first" is set to true and this valid Bit is already 1, a read clear takes precedence and This bit is clear to 0. ) bit 2: data code error (data != ~data in IR bit stream) bit 1: custom code error (custom_code != ~custom_code in IR bit stream) bit 0: 1 = received frame is repeat key, 0 = received frame is normal key

Table 13-106 AO\_MF\_IR\_DEC\_REG1 0x17

Bit(s)	R/W	Default	Description
31	R/W	0	Set to 1 to use faster timebase. .
30	R/W	0	cntl_1us_eq_clk. Just use sys_clk to relace 1uS tick.
29	R/W	0	cntl_xtal3_eq_clk. Just use sys_clk to relace 111ns tick.
28-16	R	0	Pulse Width Counter. It stores the internal counter of pulse width duration. Commonly used as time measurement when decode_mode is set to measure width mode (software decode). Time measurement starts at the last time the internal time counter was reset by the rising and/or falling edge of the IR signal. The selection of reset on rising and/or falling edge is determined by the IRQ Selection field (Bits 3-2 below)
15	R/W	0	Enable. 1 = enable the state machine of IR decoder.

Bit(s)	R/W	Default	Description
			0 = disable the state machine of IR decoder.
14	R/W	0	cntl_use_sys_clk. Use sys_clk for the timebase. It's useful when sys_clk at low frequency ( such as 32Khz ) and cannot create 1uS timebase tick. 1 = use the system clock as timebase. 0 = use the 1uS timebase tick as timebase.
13-8	R/W	0	bit_length minus 1. (N-1). Used to set the value of frame body's bit length (frame body commonly includes address and data code part). If a format has 24 bit frame body, this value shall be set to 23.
7	R/W	0	Record_at_error. 1= record the frame body and status forcibly, even if data/custom code error check enabled by frame_mask and relative error occurs. 0 = if data/custom code error check enabled by frame_mask and relative error occurs, not record the frame body and status forcibly
6	R/W	0	Hold_first Used to hold the first captured frame data. If This bit is set to 1, then the "Frame-Body/FrameBody_1" register will only be updated if hasn't already been updated. Once updated, the "FrameBody/FrameBody_1" register will not be updated again until it has been read. This bit can be used to guarantee the first TV remote code captured will not be overwritten by subsequent transmissions from a TV remote. NOTE: Read the "FrameBody" register can clear the internal "Frame data valid" flag, and read the "FrameBody_1" register can clear the "Frame data valid 1" flag.
5-4	R/W	0	Frame_mask. Some formats' body include bit-inversed data or custom/address code for error check. 00 = ignore error check from either data or custom/address code 01= check if data code matches its inverse values, ignore error check from custom/address code 10= check if custom/address code matches its inverse values, ignore error check from data code 11= check if data and custom codes match their inverse values
3-2	R/W	0	Irq_sel. IRQ Selection and width measurement reset: 00: IR Decoder done 01: IR input rising or falling edge detected 10: IR input falling edge detected 11: IR rising edge detected
1	R/W	0	IR input polarity selection. Used to adjust/invert the polarity of IR input waveform.
0	R/W	0	Decoder Reset. Set to 1 to reset the IR decoder. This is useful because the IR remote state machine thinks in terms of milliseconds and may take tens of milliseconds to return to idle by itself.

Table 13-107 AO\_MF\_IR\_DEC\_REG2 0x18

Bit(s)	R/W	Default	Description
31-27	R	0	Unused
26	R/W	0	Width_low_enable. Enable counter record of low pulse width duration. 0 = do not force enable of width low counter record 1 = force enable of width low counter record Some IR formats' decoding need to use internal width low counter record. By default, the width low counter record is enabled automatically for related formats. This bit is used for enable forcibly just in case. Besides, if "leader plus stop bit" method is enabled for repeat detection, This bit is also need to be enabled.
25	R/W	0	Width_high_enable. Enable counter record of high pulse width duration. 0 = do not force enable of width high counter record

Bit(s)	R/W	Default	Description
			1 = force enable of width high counter record Some IR formats' decoding need to use internal width high counter record. By default, the width high counter record is enabled automatically for related formats. This bit is used for enable forcibly just in case.
24	R/W	0	Enable "leader plus stop bit" method for repeat detection. 0 = "leader plus stop bit" method disabled 1 = "leader plus stop bit" method enabled Some IR formats use one normal frame's leader followed by a stop bit to represent repeat. There is no frame data in this kind repeat frame. To use this method, width_low_enable ( Bit 26 of 0x20 offset register) shall be set to 1, and max_duration_3 and min_duration_3 in 0x28 offset register shall be set to appropriate value for stop bit's timing duration.
23-22	R	0	Unused
21-16	R/W	0	Repeat_Bit_index. These Bits are used for compare bit method to set the index of the bit that is used as repeat flag. The index value can be 0 to 63. Compare bit method is one of the methods for repeat detection . Some IR formats use one bit in frame to represent whether the frame is repeat.
15	R/W	0	Running_count_tick_mode. This bit is only valid when use_clock_to_counter Bit is 0. 0 = use 100uS as increasing time unit of frame-to-frame counter 1 = use 10uS as increasing time unit of frame-to-frame counter
14	R/W	0	Use_clock_to_counter. If This bit is set to 1, the running_count_tick_mode Bit is ignored. 0 = do not use system clock as increasing time unit of frame-to-frame counter 1 = use system clock as increasing time unit of frame-to-frame counter
13	R/W	0	Enable frame-to-frame time counter (running-counter). 0 = frame-to-frame time counter disabled 1 = frame-to-frame time counter enabled If enabled, the frame-to-frame counter increases every 100uS or 10uS until it reaches its max value(all Bits are 1) or it is reset. When it reaches its max value, it keeps the value until it is reset. When it is reset, it becomes zero and then begin increasing again. The counter can be reset even when it has not reached its max value. The increasing time unit can be 100uS or 10uS or system clock frequency which is set by running_count_tick_mode and use_clock_to_counter settings. When a frame's data are captured and stored into FrameBody/FrameBody_1 register, frame-to-frame counter is reset to zero. After reset to zero, the frame-to-frame counter will begin increasing again, until it reaches its max value or it is reset. For repeat frame detection, users can use hardware detection by enabling compare frame or compare bit method, or users can read frame-to-frame counter to let software to make the decision.
12	R/W	0	Enable repeat time check for repeat detection. This bit is valid only when compare frame method or compare Bit method is enabled. 0 = repeat time check disabled 1 = repeat time check enabled When repeat frame detection is enabled by enabling compare frame or compare Bit method, the frame time interval may need to be checked in order to decide whether the frames are repeat (key pressed without release) or not. You can configure the repeat_time_max value by setting 0x38 offset register. If frame interval is smaller than the "repeat time max", it may be considered as repeat. If frame interval is bigger than the "repeat time max", it is considered as not repeat.
11	R/W	0	Enable compare frame method for repeat detection. 0 = compare frame method disabled 1 = compare frame method enabled Some IR formats transfer the same data frame as repeat frame when the key is kept pressed without release. For repeat detection, compare frame method can be used.

Bit(s)	R/W	Default	Description
			If a new frame and the old received frame are the same and the repeat time is under the limit( frame-to-frame time counter value is smaller than the repeat_time_max ), the status register's frame_status0 is set to 1 automatically as repeat detected flag. You can configure the repeat_time_max value by setting 0x38 offset register.
10	R/W	0	Enable compare Bit method for repeat detection. 0 = compare Bit method disabled 1 = compare Bit method enabled Some IR formats use only one bit to represset whether the frame is repeat. You can compare only one bit instead of compare the whole frame for repeat detection. If compare frame method is enabled, then This bit is ignored.
9	R/W	0	Disable read-clear of FrameBody/FrameBody_1. 0 = read-clear enabled 1 = read-clear disabled FrameBody/FrameBody_1 registers are read-cleared in default. When these register are read, they are cleared to zero. This bit is used to disable this read-clear feature. ( FrameBody/FrameBody_1 registers are used to store captured frame data ).
8	R/W	0	input stream bit order. 0 = LSB first mode (first bit in input stream is considered as LSB) 1= MSB first mode (first bit in input stream is considered as MSB) Note: Commonly the following formats shall set 1 to enable MSB first mode ( unless you insist on LSBfirst mode for your specified use): RC5, RC5 extend, RC6, RCMM, Duokan, Comcast
7:4	R	0	Unused
3:0	R/W	0	Decode_mode.(format selection) 0x0 =NEC 0x1= skip leader (just Bits, without leader) 0x2=General time measurement (measure width, software decode) 0x3=MITSUBISHI 0x4=Thomson 0x5=Toshiba 0x6=Sony SIRC 0x7=RC5 0x8=Reserved 0x9=RC6 0xA=RCMM 0xB=Duokan 0xC=Reserved 0xD=Reserved 0xE=Comcast 0xF=Sanyo

Table 13-108 AO\_MF\_IR\_DEC\_DURATN2 0x19

Bit(s)	R/W	Default	Description
31-26	R	0	Unused
25-16	R/W	0	Max duration of Duration Setting Register 2. It defines max duration for: Half bit for RC5/6 format (RC5 typically 888.89us for half bit, RC6 typically 444.44us) or time of Duokan/RCMM/4ppm format's Logic "10" or time of Comcast/16ppm's base duration

Bit(s)	R/W	Default	Description
15-10	R	0	Unused
9-0	R/W	0	Min duration of Duration Setting Register 2.

Table 13-109 AO\_MF\_IR\_DEC\_DURATN3 0x1a

Bit(s)	R/W	Default	Description
31-26	R	0	Unused
25-16	R/W	0	Max duration of Duration Setting Register 3. It defines max duration for: Whole bit for RC5/6 format (RC5 typically 1777.78us for whole bit, RC6 typically 888.89us) or time of Duokan/RCMM/4ppm format's Logic "11" or time of Comcast/16ppm's offset duration
15-10	R	0	Unused
9-0	R/W	0	Min duration of Duration Setting Register 3.

Table 13-110 AO\_MF\_IR\_DEC\_FRAME: Frame Body ( Frame Data, LSB 32Bit ) 0x1b

Bit(s)	R/W	Default	Description
31-0	R	0	32 bit Read-Only register stores frame body (LSB 32 bit) captured from IR remote data flow, commonly includes custom/address code and data code.

**Note**

New keys will be ignored until **FrameBody** register is read if the hold first key Bit is set in the de-code control register. Reading this register resets an internal frame data valid flag.

Table 13-111 AO\_MF\_IR\_DEC\_FRAME: Frame Body 1 ( Frame Data, MSB 32Bit ) 0x1b

Bit(s)	R/W	Default	Description
31-0	R	0	Stores frame body excess 32 bit range. (MSB 32 bit)

**Note**

New keys will be ignored until **FrameBody** register is read if the hold first key Bit is set in the de-code control register. Reading this register resets an internal frame data valid flag.

Table 13-112 AO\_MF\_IR\_DEC\_STATUS\_1 0x1c

Bit(s)	R/W	Default	Description
31-20	R	0	Unused
19-0	R	0	Stores the last frame-to-frame counter value before the last counter reset caused by the last frame data record/update.

Table 13-113 AO\_MF\_IR\_DEC\_STATUS\_2 0x1d

Bit(s)	R/W	Default	Description
31-20	R	0	Unused
19-0	R	0	Stores the value of the frame-to-frame counter which is running currently.

## 13.7 Pulse-Width Modulation

### 13.7.1 Overview

The chip has 5 PWM modules that can be connected to various digital I/O pins, among which 3 are in EE domain and 2 is in AO domain. Each PWM is driven by a programmable divider driven by a 4:1 clock selector. The PWM signal is generated using two 16-bit counters. One is the High and Low counter, which is individually programmable with values between 1 and 65535. Using a combination of the divided clock (divide by N) and the HIGH and LOW counters, a wide number of PWM configurations are possible. The other is delta-sigma counter, generate 18-bit sigma, the PWM-out is the highest sigma. The PWM outputs vs counters are also illustrate below.

Figure 13-6 PWM Block Diagram

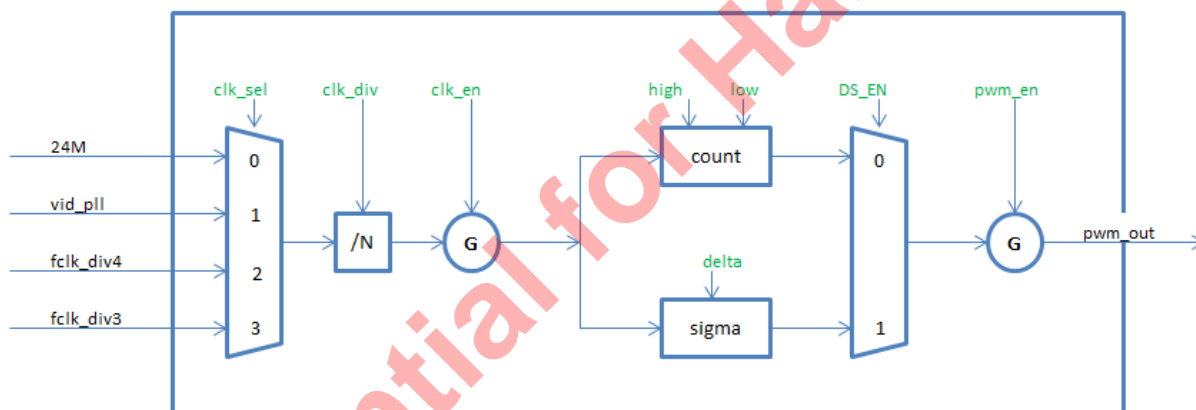

Figure 13-7 High/Low Counter

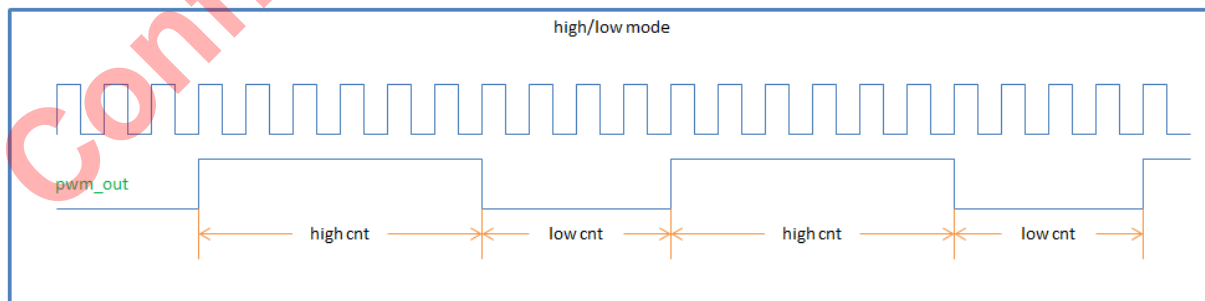
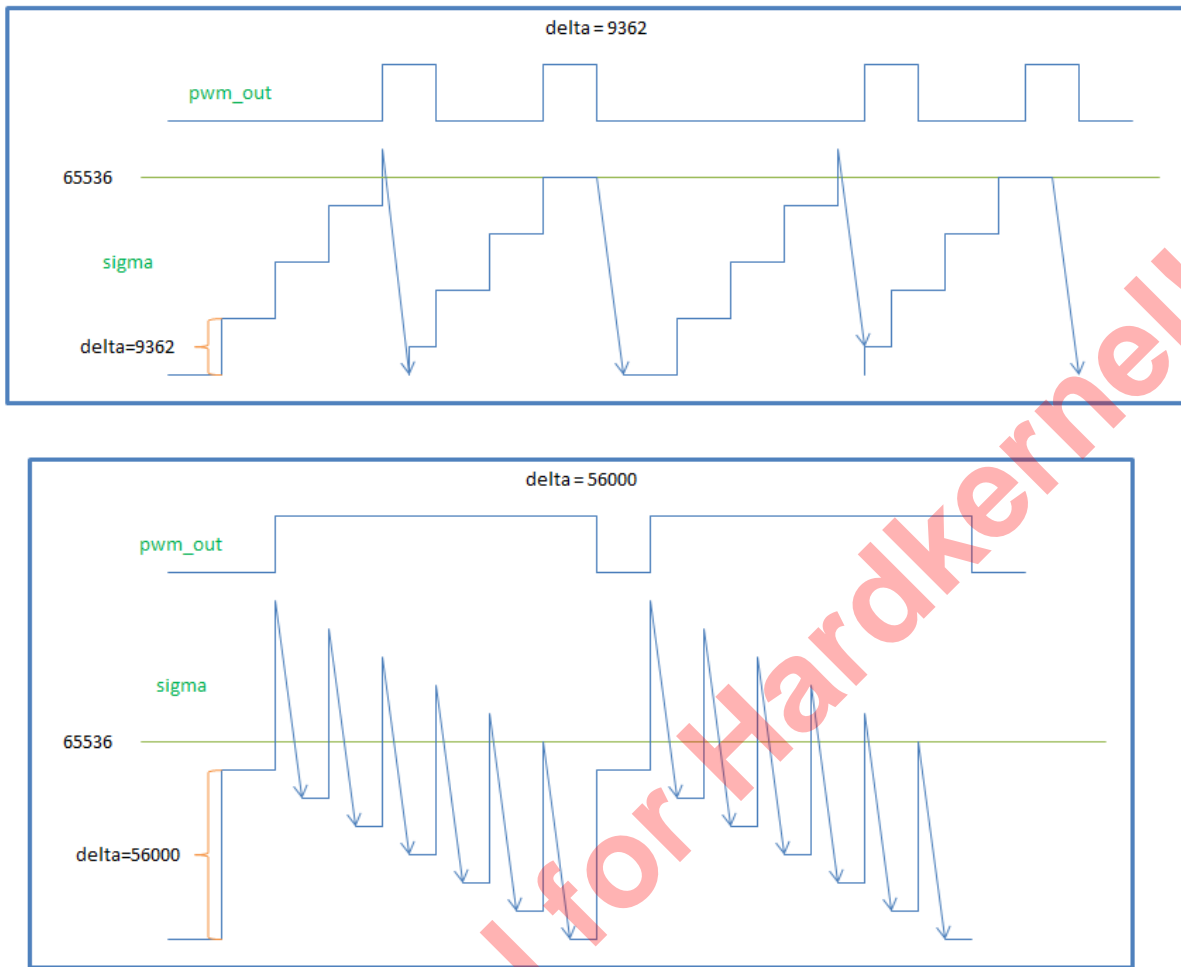
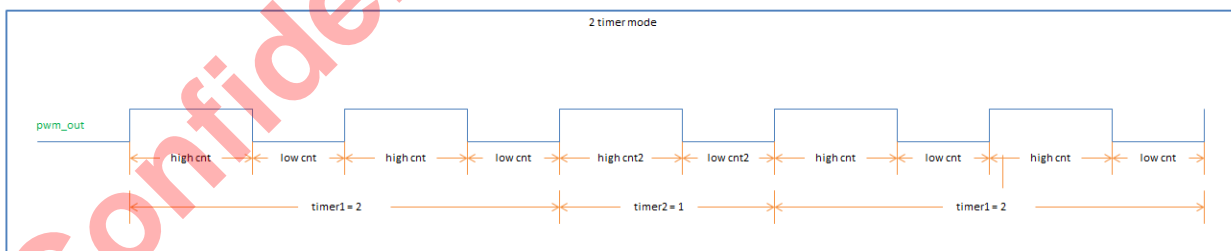

Figure 13-8 Delta-sigma Center



PWM 2 timer mode is illustrated as following:

Figure 13-9 2 Timer Mode



### 13.7.2 Register Description

Each PWM module contains two PWM generators call A and B and controlled by the following registers. For PWM modules in EE domain, the each register's final address = 0xffd00000 + offset\*4

**Table 13-114 PWM\_PWM\_A 0x6c00**

Bit(s)	R/W	Default	Description
31-15	R/W	0x86	PWM_A_HIGH: This sets the high time (in clock counts) for the PWM_A generator output
15-0	R/W	0x86	PWM_A_LOW: This sets the high time (in clock counts) for the PWM_A generator output

**Table 13-115 PWM\_PWM\_B 0x6c01**

Bit(s)	R/W	Default	Description
31-15	R/W	0x50	PWM_B_HIGH: This sets the high time (in clock counts) for the PWM_B generator output
15-0	R/W	0x8	PWM_B_LOW: This sets the high time (in clock counts) for the PWM_B generator output

**Table 13-116 PWM\_MISC\_REG\_AB 0x6c02**

Bit(s)	R/W	Default	Description
31	R/W	0	pwm_B_hiz when hiz mode, pwm_o will connect to pad_oe, then pad_o will equal this bit
30	R/W	0	pwm_A_hiz when hiz mode, pwm_o will connect to pad_oe, then pad_o will equal this bit
29	R/W	0	pwm_B_constant_en
28	R/W	0	pwm_A_constant_en
27	R/W	0	pwm_B_inv_en
26	R/W	0	pwm_A_inv_en
25	R/W	0	cntl_pwm_a2_en
24	R/W	0	cntl_pwm_b2_en
23	R/W	0	PWM_B_CLK_EN: Set this bit to 1 to enable PWM B clock
22-16	R/W	0	PWM_B_CLK_DIV: Selects the divider (N+1) for the PWM B clock. See the clock tress document
15	R/W	0	PWM_A_CLK_EN: Set this bit to 1 to enable PWM A clock
14-8	R/W	0	PWM_A_CLK_DIV: Selects the divider (N+1) for the PWM A clock. See the clock tress document
7-6	R/W	0	PWM_B_CLK_SEL: Select the clock for the PWM B. See the clock tress document
5-4	R/W	0	PWM_A_CLK_SEL: Select the clock for the PWM A. See the clock tress document
3	R/W	0	DS_B_EN: This bit is only valid if PWM_B_EN is 0: if this bit is set to 1, then the PWM_B output is configured to generate a delta sigma output based on the settings in the register below. If this bit is set to 0, then the PWM_B output is set low.
2	R/W	0	DS_A_EN: This bit is only valid if PWM_A_EN is 0: if this bit is set to 1, then the PWM_A output is configured to generate a delta sigma output based on the settings in the register below. If this bit is set to 0, then the PWM_A output is set low.



Bit(s)	R/W	Default	Description
1	R/W	0	PWM_B_EN: If this bit is set to 1, then the PWM_B output is configured to generate a PWM output based on the register above. If this bit is 0, then the PWM_B output is controlled by DS_B_EN above.
0	R/W	0	PWM_A_EN: If this bit is set to 1, then the PWM_A output is configured to generate a PWM output based on the register above. If this bit is 0, then the PWM_A output is controlled by DS_A_EN above.

Table 13-117 DS\_A\_B 0x6c03

Bit(s)	R/W	Default	Description
31-15	R/W	0x8000	DS_B_VAL: This value represents the delta sigma setting for channel B (PWM_B)
15-0	R/W	0x8000	DS_A_VAL: This value represents the delta sigma setting for channel A (PWM_A)

Table 13-118 PWM\_TIME\_AB 0x6c04

Bit(s)	R/W	Default	Description
31-24	R/W	0xa	A_timer1
23:16	R/W	0xa	A_timer2
15:8	R/W	0xa	B_timer1
7:0	R/W	0xa	B_timer2

Table 13-119 PWM\_A2 0x6c05

Bit(s)	R/W	Default	Description
31-15	R/W	0x86	PWM_A2_HIGH: This sets the high time (in clock counts) for the PWM_A2 generator output
15-0	R/W	0x86	PWM_A2_LOW: This sets the high time (in clock counts) for the PWM_A2 generator output

Table 13-120 PWM\_B2 0x6c06

Bit(s)	R/W	Default	Description
31-15	R/W	0x50	PWM_B2_HIGH: This sets the high time (in clock counts) for the PWM_B2 generator output
15-0	R/W	0x8	PWM_B2_LOW: This sets the high time (in clock counts) for the PWM_B2 generator output

Table 13-121 PWM\_BLINK\_AB 0x6c07

Bit(s)	R/W	Default	Description
31-10	R	0	Reserved
9	R/W	0	blink enable for pwm B

Bit(s)	R/W	Default	Description
8	R/W	0	blink enable for pwm A
7-4	R/W	0	blink times for pwm B
3-0	R/W	0	blink times for pwm A

PWM\_PWM\_C\_D: 0x6800~0x6807

See the registers for PWM A/B

PWM\_PWM\_E\_F: 0x6400~0x6407

See the registers for PWM A/B

AO PWM' clock sources are xtal, clk81, fclk\_div3, fclk\_div4.

For the following register, each register's final address = 0xFF807000 + offset\*4

**Table 13-122 AO\_PWM\_PWM\_A: PWM\_A\_DUTY\_CYCLE 0x0**

Bit(s)	R/W	Default	Description
31-15	R/W	0	PWM_A_HIGH: This sets the high time (in clock counts) for the PWM_A generator output
15-0	R/W	0	PWM_A_LOW: This sets the high time (in clock counts) for the PWM_A generator output

**Table 13-123 AO\_PWM\_PWM\_B: PWM\_B\_DUTY\_CYCLE 0x1**

Bit(s)	R/W	Default	Description
31-15	R/W	0	PWM_B_HIGH: This sets the high time (in clock counts) for the PWM_B generator output
15-0	R/W	0	PWM_B_LOW: This sets the high time (in clock counts) for the PWM_B generator output

**Table 13-124 AO\_PWM\_MISC\_REG\_AB: 0x2**

Bit(s)	R/W	Default	Description
31	R/W	0	pwm_B_hiz when hiz mode, pwm_o will connect to pad_oe, then pad_o will equal this bit
30	R/W	0	pwm_A_hiz when hiz mode, pwm_o will connect to pad_oe, then pad_o will equal this bit
29	R/W	0	pwm_B_constant_en set this bit to 1, then pwm can support 0%(100%) duty output
28	R/W	0	pwm_A_constant_en set this bit to 1, then pwm can support 0%(100%) duty output
27	R/W	0	pwm_B_inv_en set this bit to 1, pwm output is inverted
26	R/W	0	pwm_A_inv_en set this bit to 1, pwm output is inverted
25	R/W	0	Pwm_a2_en
24	R/W	0	Pwm_b2_en

Bit(s)	R/W	Default	Description
23	R/W	0	PWM_B_CLK_EN: Set this bit to 1 to enable PWM B clock
22-16	R/W	0	PWM_B_CLK_DIV: Selects the divider (N+1) for the PWM B clock. See the clock tress document
15	R/W	0	PWM_A_CLK_EN: Set this bit to 1 to enable PWM A clock
14-8	R/W	0	PWM_A_CLK_DIV: Selects the divider (N+1) for the PWM A clock. See the clock tress document
7-6	R/W	0	PWM_B_CLK_SEL: Select the clock for the PWM B. See the clock tress document
5-4	R/W	0	PWM_A_CLK_SEL: Select the clock for the PWM A. See the clock tress document
3	R/W	0	DS_B_EN: This bit is only valid if PWM_B_EN is 0: if this bit is set to 1, then the PWM_B output is configured to generate a delta sigma output based on the settings in the register below. If this bit is set to 0, then the PWM_B output is set low.
2	R/W	0	DS_A_EN: This bit is only valid if PWM_A_EN is 0: if this bit is set to 1, then the PWM_A output is configured to generate a delta sigma output based on the settings in the register below. If this bit is set to 0, then the PWM_A output is set low.
1	R/W	0	PWM_B_EN: If this bit is set to 1, then the PWM_B output is configured to generate a PWM output based on the register above. If this bit is 0, then the PWM_B output is controlled by DS_B_EN above.
0	R/W	0	PWM_A_EN: If this bit is set to 1, then the PWM_A output is configured to generate a PWM output based on the register above. If this bit is 0, then the PWM_A output is controlled by DS_A_EN above.

Table 13-125 AO\_PWM\_DELTA\_SIGMA\_AB 0x3

Bit(s)	R/W	Default	Description
31-15	R/W	0	DS_B_VAL: This value represents the delta sigma setting for channel B (PWM_B)
15-0	R/W	0	DS_A_VAL: This value represents the delta sigma setting for channel A (PWM_A)

Table 13-126 AO\_PWM\_TIME\_AB 0x4

Bit(s)	R/W	Default	Description
31-24	R/W	0	A1_timer
23:16	R/W	0	A2_timer
15:8	R/W	0	B1_timer
7:0	R/W	0	B2_timer

Table 13-127 AO\_PWM\_A2 0x5

Bit(s)	R/W	Default	Description
31-15	R/W	0	PWM_A2_HIGH: This sets the high time (in clock counts) for the PWM_A2 generator output
15-0	R/W	0	PWM_A2_LOW: This sets the high time (in clock counts) for the PWM_A2 generator output

**Table 13-128 AO\_PWM\_B2 0x6**

Bit(s)	R/W	Default	Description
31-15	R/W	0	PWM_B2_HIGH: This sets the high time (in clock counts) for the PWM_B 2 generator output
15-0	R/W	0	PWM_B2_LOW: This sets the high time (in clock counts) for the PWM_B 2 generator output

**Table 13-129 AO\_PWM\_BLINK\_AB 0x7**

Bit(s)	R/W	Default	Description
31-10	R	0	Reserved
9	R/W	0	blink enable for pwm B
8	R/W	0	blink enable for pwm A
7-4	R/W	0	blink times for pwm B
3-0	R/W	0	blink times for pwm A

For the following register, each register's final address= 0xFF802000 + offset \* 4

**Table 13-130 AO\_PWM\_PWM\_C: PWM\_C\_DUTY\_CYCLE 0x0**

Bit(s)	R/W	Default	Description
31-15	R/W	0	PWM_C_HIGH: This sets the high time (in clock counts) for the PWM_C generator output
15-0	R/W	0	PWM_C_LOW: This sets the high time (in clock counts) for the PWM_C generator output

**Note**

This is a new module to Nike. It replaces the older delta sigma (PWM like) generator in the HIU. This module allows the software to select either a PWM or delta-sigma output using the same module. There are two outputs: PWM\_A and PWM\_B. Either of these can be programmed to be PWM outputs or delta sigma outputs.

**Table 13-131 AO\_PWM\_PWM\_D: PWM\_D\_DUTY\_CYCLE 0x1**

Bit(s)	R/W	Default	Description
31-15	R/W	0	PWM_D_HIGH: This sets the high time (in clock counts) for the PWM_D generator output
15-0	R/W	0	PWM_D_LOW: This sets the high time (in clock counts) for the PWM_D generator output

Table 13-132 AO\_PWM\_MISC\_REG\_CD: 0x2

Bit(s)	R/W	Default	Description
31	R/W	0	pwm_D_hiz when hiz mode, pwm_o will connect to pad_oe, then pad_o will equal this bit
30	R/W	0	pwm_C_hiz when hiz mode, pwm_o will connect to pad_oe, then pad_o will equal this bit
29	R/W	0	pwm_D_constant_en set this bit to 1, then pwm can support 0%(100%) duty output
28	R/W	0	pwm_C_constant_en set this bit to 1, then pwm can support 0%(100%) duty output
27	R/W	0	pwm_D_inv_en set this bit to 1, pwm output is inverted
26	R/W	0	pwm_C_inv_en set this bit to 1, pwm output is inverted
25	R/W	0	Pwm_C2_en
24	R/W	0	Pwm_D2_en
23	R/W	0	PWM_D_CLK_EN: Set this bit to 1 to enable PWM Dclock
22-16	R/W	0	PWM_D_CLK_DIV: Selects the divider (N+1) for the PWM Dclock. See the clock tress document
15	R/W	0	PWM_C_CLK_EN: Set this bit to 1 to enable PWM C clock
14-8	R/W	0	PWM_C_CLK_DIV: Selects the divider (N+1) for the PWM C clock. See the clock tress document
7-6	R/W	0	PWM_D_CLK_SEL: Select the clock for the PWM D. See the clock tress document
5-4	R/W	0	PWM_C_CLK_SEL: Select the clock for the PWM C. See the clock tress document
3	R/W	0	DS_D_EN: This bit is only valid if PWM_D_EN is 0: if this bit is set to 1, then the PWM_D output is configured to generate a delta sigma output based on the settings in the register below. If this bit is set to 0, then the PWM_D output is set low.
2	R/W	0	DS_C_EN: This bit is only valid if PWM_C_EN is 0: if this bit is set to 1, then the PWM_C output is configured to generate a delta sigma output based on the settings in the register below. If this bit is set to 0, then the PWM_C output is set low.
1	R/W	0	PWM_D_EN: If this bit is set to 1, then the PWM_D output is configured to generate a PWM output based on the register above. If this bit is 0, then the PWM_D output is controlled by DS_D_EN above.
0	R/W	0	PWM_C_EN: If this bit is set to 1, then the PWM_C output is configured to generate a PWM output based on the register above. If this bit is 0, then the PWM_C output is controlled by DS_C_EN above.

**Table 13-133 AO\_PWM\_DELTA\_SIGMA\_CD 0x3**

Bit(s)	R/W	Default	Description
31-15	R/W	0	DS_D_VAL: This value represents the delta sigma setting for channel D (PWM_D)
15-0	R/W	0	DS_C_VAL: This value represents the delta sigma setting for channel C (PWM_C)

**Table 13-134 AO\_PWM\_TIME\_CD 0x4**

Bit(s)	R/W	Default	Description
31-24	R/W	0	C1_timer
23:16	R/W	0	C2_timer
15:8	R/W	0	D1_timer
7:0	R/W	0	D2_timer

**Table 13-135 AO\_PWM\_C2 0x5**

Bit(s)	R/W	Default	Description
31-15	R/W	0	PWM_C2_HIGH: This sets the high time (in clock counts) for the PWM_C generator output
15-0	R/W	0	PWM_C2_LOW: This sets the high time (in clock counts) for the PWM_C generator output

**Table 13-136 AO\_PWM\_D2 0x6**

Bit(s)	R/W	Default	Description
31-15	R/W	0	PWM_D2_HIGH: This sets the high time (in clock counts) for the PWM_D generator output
15-0	R/W	0	PWM_D2_LOW: This sets the high time (in clock counts) for the PWM_D generator output

**Table 13-137 AO\_PWM\_BLINK\_CD 0x7**

Bit(s)	R/W	Default	Description
31-10	R	0	Reserved
9	R/W	0	blink enable for pwm D
8	R/W	0	blink enable for pwm C
7-4	R/W	0	blink times for pwm D
3-0	R/W	0	blink times for pwm C

## 13.8 SAR ADC

### 13.8.1 Overview

This SAR ADC is a general purpose ADC for measuring analog signals. The module can make RAW ADC measurements or average a number of measurements to introduce filtering. The SAR ADC is a single block so an analog mux is placed in front to allow multiple different measurements to be made sequentially. Timing of the samples, and delays between muxing are all programmable as is the averaging to be applied to the SAR ADC.

### 13.8.2 Register Description

Each register final address = 0xff809000 + offset \* 4

**Table 13-138 SAR\_ADC\_REG0: Control Register #0 0x80**

Bit(s)	R/W	Default	Description
31	R	0	PANEL_DETECT level.
30	R	0	DELTA_BUSY: If This bit is 1, then it indicates the delta processing engine is busy
29	R	0	AVG_BUSY: If This bit is 1, then it indicates the averaging engine is busy
28	R	0	SAMPLE_BUSY: If This bit is 1, then it indicates the sampling engine is busy
27	R	0	FIFO_FULL:
26	R	0	FIFO_EMPTY:
25-21	R/W	4	FIFO_COUNT: Current count of samples in the acquisition FIFO
20-19	R/W	0	ADC_BIAS_CTRL
18-16	R/W	0	CURR_CHAN_ID: These Bits represent the current channel (0..7) that is being sampled.
15	R	0	Unused
14	R/W	0	SAMPLING_STOP: This bit can be used to cleanly stop the sampling process in the event that continuous sampling is enabled. To stop sampling, simply set This bit and wait for all processing modules to no longer indicate that they are busy.
13-12	R/W	0	CHAN_DELTA_EN: There are two Bits corresponding to Channels 0 and 1. Channel 0 and channel 1 can be individually enabled to take advantage of the delta processing module.
11	R/W	0	Unused
10	R/W	0	DETECT_IRQ_POL: This bit sets the polarity of the detect signal. The detect signal is used during X/Y panel applications to detect if the panel is touched
9	R/W	0	DETECT_IRQ_EN: If This bit is set to 1, then an interrupt will be generated if the DETECT signal is low/high. The polarity is set in the bit above.
8-4	R/W	0	FIFO_CNT_IRQ: When the FIFO contains N samples, then generate an interrupt (if bit 3 is set below).
3	R/W	0	FIFO_IRQ_EN: Set This bit to 1 to enable an IRQ when the acquisition FIFO reaches a certain level.
2	W	0	SAMPLE_START: This bit should be written to 1 to start sampling.
1	R/W	0	CONTINUOUS_EN: If This bit is set to 1, then the channel list will be continually processed
0	R/W	0	SAMPLING_ENABLE: Setting This bit to '1' enables the touch panel controller sampling engine, averaging module, XY processing engine and the FIFO.

**Table 13-139 SAR\_ADC\_CHAN\_LIST:Channel List 0x81**

Bit(s)	R/W	Default	Description
31-27	R/W	0	unused
26-24	R/W	2	Length of the list of channels to process. If this value is 2, then only channels in Bits [8:0] below are processed.
23-21	R/W	7	8th channel
20-18	R/W	6	7th channel
17-15	R/W	5	6th channel
14-12	R/W	4	5th channel
11-9	R/W	3	4th channel
8-6	R/W	2	3rd channel
5-3	R/W	1	2nd channel
2-0	R/W	0	First channel in the list of channels to process

**Table 13-140 SAR\_ADC\_AVG\_CNTL:Sampling/Averaging Modes 0x82**

Bit(s)	R/W	Default	Description
31-30	R/W	0	Channel 7: Averaging mode: 0 = no averaging, 1 = simple averaging, 2 = median averaging.
29-28	R/W	0	Channel 6: Averaging mode: 0 = no averaging, 1 = simple averaging, 2 = median averaging.
27-26	R/W	0	Channel 5: Averaging mode: 0 = no averaging, 1 = simple averaging, 2 = median averaging.
25-24	R/W	0	Channel 4: Averaging mode: 0 = no averaging, 1 = simple averaging, 2 = median averaging.
23-22	R/W	0	Channel 3: Averaging mode: 0 = no averaging, 1 = simple averaging, 2 = median averaging.
21-20	R/W	0	Channel 2: Averaging mode: 0 = no averaging, 1 = simple averaging, 2 = median averaging.
19-18	R/W	0	Channel 1: Averaging mode: 0 = no averaging, 1 = simple averaging, 2 = median averaging.
17-16	R/W	0	Channel 0: Averaging mode: 0 = no averaging. 1 = simple averaging of the number of samples acquired (1,2,4 or 8). 2 = median averaging. NOTE: If these Bits are set to 2, then you must set the number of samples to acquire below to 8.
15-13	R/W	0	Channel 7: Number of samples to acquire 2N:
13-12	R/W	0	Channel 6: Number of samples to acquire 2N:
11-10	R/W	0	Channel 5: Number of samples to acquire 2N:
9-8	R/W	0	Channel 4: Number of samples to acquire 2N:
7-6	R/W	0	Channel 3: Number of samples to acquire 2N:
5-4	R/W	0	Channel 2: Number of samples to acquire 2N:
3-2	R/W	0	Channel 1: Number of samples to acquire 2N:
1-0	R/W	0	Channel 0: Number of samples to acquire 2N: 0 = 1, 1 = 2, 2 = 4, 4 = 8.



Each channel listed in the CHANNEL\_LIST is given independent control of the number of samples to acquire and averaging mode.

**Table 13-141 SAR\_ADC\_REG3: Control Register #3 0x83**

Bit(s)	R/W	Default	Description
31	R/W	0	CNTL_USE_SC_DLY: hold time delay was added to the start conversion clock. Unfortunately, it appears that the analog ADC design requires that we use the inverted clock so This bit is meaningless.
30	R/W	0	SAR_ADC_CLK_EN: 1 = enable the SAR ADC clock
29	R/W	0	reserved
28	R/W	0	reserved
27	R/W	0	SARADC_CTRL[4]: is used to control the internal ring counter. 1 = enable the continuous ring counter. 0 = disable
26	R/W	0	SARADC_CTRL[3]: used to select the internal sampling clock phase
25~23	R/W	0	SARADC_CTRL[2:0]: 000 ssa 001 vdda/4 010 vdda/2 011 vdda*3/4 100 vdda 101, 110, 111 unused
22	R/W	0	DETECT_EN: This bit controls the analog switch that connects a 50k resistor to the X+ signal. Setting This bit to 1 closes the analog switch
21	R/W	0	ADC_EN: Set This bit to 1 to enable the ADC
20-18	R/W	2	PANEL_DETECT_COUNT: Increasing this value increases the filtering on the panel detect signal using the timebase settings in Bits [17:16] below.
17-16	R/W	0	PANEL_DETECT_FILTER_TB: 0 = count 1uS ticks, 1 = count 10uS ticks, 2 = count 100uS ticks. 3 = count 1mS ticks
15-10	R/W	20	ADC_CLK_DIV: The ADC clock is derived by dividing the 27Mhz crystal by N+1. This value divides the 27Mhz clock to generate an ADC clock. A value of 20 for example divides the 27Mhz clock by 21 to generate an equivalent 1.28Mhz clock.
9-8	R/W	1	BLOCK_DLY_SEL: 0 = count 1uS ticks, 1 = count 10uS ticks, 2 = count 100uS ticks. 3 = count 1mS ticks
7-0	R/W	10	BLOCK_DLY: After all channels in the CHANNEL_LIST have been processed, the sampling engine will delay for an amount of time before re-processing the CHANNEL_LIST again. Combined with Bits [9:8] above, this value is used to generate a delay between processing blocks of channels.

Figure 13-10 SAR\_ADC\_REG3

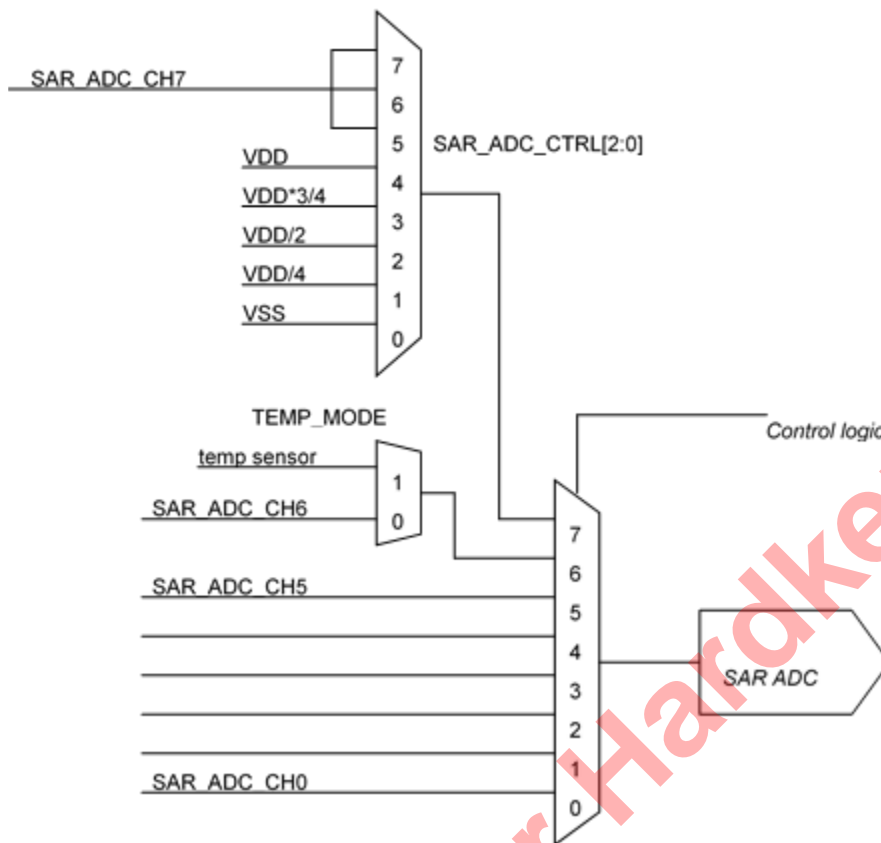

As the CHANNEL\_LIST is process, the input switches are set according to the requirements of the channel. After setting the switches there is a programmable delay before sampling begins. Additionally, each channel specifies the number of samples for that particular channel. The sampling rate is programmed below.

Table 13-142 SAR\_ADC\_DELAY:INPUT / SAMPLING DELAY 0x84

Bit(s)	R/W	Default	Description
31-29	R	0	unused
28	R/W	0	CNTL_EOC_BY_CNT: ADC dout valid controlled by counter
27	R/W	0	CNTL_USE_LATCHED_DATA: ADC dout be latched first, then be sampled
26	R	0	unused
25-24	R/W	0	INPUT_DLY_SEL: 0 = 111nS ticks, 1 = count 1uS ticks, 2 = count 10uS ticks, 3 = count 100uS ticks
23-16	R/W	3	INPUT_DLY_CNY: For channels that acquire 2,4 or 8 samples, the delay between two samples is controlled by this count (N+1) combined with the delay selection in the two bits above.
15-10	R/W	14	CNTL_EOC_DLY_CNT: the delay between SC and ADC output data ready for latch/sample
9-8	R/W	0	SAMPLE_DLY_SEL: 0 = count 1uS ticks, 1 = count 10uS ticks, 2 = count 100uS ticks. 3 = count 1mS ticks
7-0	R/W	9	SAMPLE_DLY_CNY: For channels that acquire 2,4 or 8 samples, the delay between two samples is controlled by this count (N+1) combined with the delay selection in the two bits above.

For channel 0 and channel 1, (the special X/Y channels) the last sample pushed into the FIFO for each channel is saved in a register. This allows the software to see the last sample for channel 0 and channel 1 even when the FIFO overflows. For example, if we are sampling quickly and there is a gesture on the screen, we can use the contents of the FIFO to see the direction of the gesture and use the last sample values to see where the pen finally came to rest.

**Table 13-143 SAR\_ADC\_LAST\_RD: Last Sample 0x85**

Bit(s)	R/W	Default	Description
31-24	R	0	unused
23-16	R	0	LAST_CHANNEL1
15-10	R	0	unused
9-0	R	0	LAST_CHANNEL0

**Table 13-144 SAR\_ADC\_FIFO\_RD: Control Register #6 (FIFO RD) 0x86**

Bit(s)	R/W	Default	Description
31-16	R	0	Unused
15	R	0	Unused
14-12	R	0	Channel ID. This value identifies the channel associated with the data in Bits [9:0] below
11-0	R	0	Sample value: 12-bit raw or averaged ADC sample written to the FIFO.

Channels 2 ~ 7 can program the ADC input mux to any selection between 0 and 7. This register allows the software to associate a mux selection with a particular channel. In addition to the ADC mux, there are a number of switches that can be set in any particular state. Channels 2 ~ 7 share a common switch setting. Channels 0 and 1 on the other hand have programmable switch settings (see other registers below).

**Table 13-145 SAR\_ADC\_AUX\_SW: Channel 2~7 ADC MUX, Switch Controls 0x87**

Bit(s)	R/W	Default	Description
31	R	0	unused
30	R/W	0	CNTL_MANUAL_SC
29	R/W	0	CNTL_MANUAL_CLK
28	R/W	0	CNTL_MANUAL_MODE
25-23	R/W	7	Channel 7 ADC_MUX setting when channel 7 is being measured.
22-20	R/W	7	Channel 6 ADC_MUX setting when channel 6 is being measured.
19-17	R/W	7	Channel 5 ADC_MUX setting when channel 5 is being measured.
16-14	R/W	6	Channel 4 ADC_MUX setting when channel 4 is being measured.
13-11	R/W	0	Channel 3 ADC_MUX setting when channel 3 is being measured.
10-8	R/W	1	Channel 2 ADC_MUX setting when channel 2 is being measured.
7	R	0	unused
6	R/W	0	VREF_P_MUX setting when channel 2,3..7 is being measured
5	R/W	0	VREF_N_MUX setting when channel 2,3..7 is being measured

Bit(s)	R/W	Default	Description
4	R/W	0	MODE_SEL setting when channel 2,3..7 is being measured
3	R/W	1	YP_DRIVE_SW setting when channel 2,3..7 is being measured
2	R/W	1	XP_DRIVE_SW setting when channel 2,3..7 is being measured
1	R/W	0	YN_DRIVE_SW setting when channel 2,3..7 is being measured
0	R/W	0	XN_DRIVE_SW setting when channel 2,3..7 is being measured

Channels 0 and 1 have independent programmable switch settings when either/both of these channels are being measured.

**Table 13-146 SAR\_ADC\_CHAN\_10\_SW:Channel 0, 1 ADC MUX, Switch Controls 0x88**

Bit(s)	R/W	Default	Description
31-26	R	0	unused
25-23	R/W	2	Channel 1 ADC MUX setting
22	R/W	0	Channel 1 VREF_P_MUX
21	R/W	0	Channel 1 VREF_N_MUX
20	R/W	0	Channel 1 MODE_SEL
19	R/W	1	Channel 1 YP_DRIVE_SW setting: 0: TADC_CH6N = 3.3v 1: TADC_CH6N = floating
18	R/W	1	Channel 1 XP_DRIVE_SW setting: 0: TADC_CH6N = 3.3v 1: TADC_CH6N = floating
17	R/W	0	Channel 1 YN_DRIVE_SW setting: 0: TADC_CH4N = floating 1: TADC_CH4N = GND
16	R/W	0	Channel 1 XN_DRIVE_SW setting: 0: TADC_CH4N = floating 1: TADC_CH4N = GND
15-10	R		unused
9-7	R/W	3	Channel 0 ADC MUX setting
6	R/W	0	Channel 0 VREF_P_MUX
5	R/W	0	Channel 0 VREF_N_MUX
4	R/W	0	Channel 0 MODE_SEL
3	R/W	1	Channel 0 YP_DRIVE_SW setting: 0: TADC_CH6N = 3.3v 1: TADC_CH6N = floating
2	R/W	1	Channel 0 XP_DRIVE_SW setting: 0: TADC_CH6N = 3.3v 1: TADC_CH6N = floating

Bit(s)	R/W	Default	Description
1	R/W	0	Channel 0 YN_DRIVE_SW setting: 0: TADC_CH4N = floating 1: TADC_CH4N = GND
0	R/W	0	Channel 0 XN_DRIVE_SW setting: 0: TADC_CH4N = floating 1: TADC_CH4N = GND

**IDLE MODE:** When nothing is being measured, the switches should be put into a safe state. This safe state is accomplished using Bits [9:0] below.

**DETECT MODE:** When bit [26] is set, the input muxes / switches are configured according to the Bits below. Typically the software configures the switches below to correspond to the detect touch mode. That is, Y- internal MOSFET is closed so that the Y plane of the touch screen is connected to Ground. Additionally, the DETECT\_EN bit (different register) set to 1 so that the 50k resistor to VDD is connected to X+. In this configuration, the detect comparator connected to the 50k resistor will be weakly pulled up to VDD through the 50k resistor. If the user touches the screen, the X and Y planes of the touch screen will contact causing the X+ signal to be pulled to ground.

**Table 13-147 SAR\_ADC\_DETECT\_IDLE\_SW:DETECT / IDLE Mode switches 0x89**

Bit(s)	R/W	Default	Description
31-27	R	0	unused
26	R/W	0	DETECT_SW_EN: If This bit is set, then Bits [25:16] below are applied to the analog muxes/switches of the touch panel controller.
25-23	R/W	5	DETECT MODE ADC MUX setting
22	R/W	0	DETECT MODE VREF_P_MUX setting
21	R/W	0	DETECT MODE VREF_N_MUX setting
20	R/W	0	DETECT MODE MODE_SEL setting
19	R/W	1	DETECT MODE YP_DRIVE_SW setting: 0: TADC_CH6N = 3.3v 1: TADC_CH6N = floating
18	R/W	1	DETECT MODE XP_DRIVE_SW setting: 0: TADC_CH6N = 3.3v 1: TADC_CH6N = floating
17	R/W	0	DETECT MODE YM_DRIVE_SW setting: 0: TADC_CH4N = floating 1: TADC_CH4N = GND
16	R/W	0	DETECT MODE YM_DRIVE_SW setting: 0: TADC_CH4N = floating 1: TADC_CH4N = GND
15-10	R		Unused
9-7	R/W	5	IDLE MODE ADC MUX setting
6	R/W	0	IDLE MODE VREF_P_MUX setting
5	R/W	0	IDLE MODE VREF_N_MUX setting
4	R/W	0	IDLE MODE MODE_SEL setting
3	R/W	1	IDLE MODE YP_DRIVE_SW setting: 0: TADC_CH6N = 3.3v 1: TADC_CH6N = floating

Bit(s)	R/W	Default	Description
2	R/W	1	IDLE MODE XP_DRIVE_SW setting: 0: TADC_CH6N = 3.3v 1: TADC_CH6N = floating
1	R/W	0	IDLE MODE YN_DRIVE_SW setting: 0: TADC_CH4N = floating 1: TADC_CH4N = GND
0	R/W	0	IDLE MODE XN_DRIVE_SW setting: 0: TADC_CH4N = floating 1: TADC_CH4N = GND

Table 13-148 SAR\_ADC\_DELTA\_10:Delta Mode Deltas 0x8a

Bit(s)	R/W	Default	Description
31-28	R	0	unused
27-16	R/W	0	Channel 1 delta value when delta processing for channel 1 is enabled.
15-12	R/W		unused
11-0	R/W	0	Channel 0 delta value when delta processing for channel 0 is enabled.

Table 13-149 SAR\_ADC\_REG11: 0x8b

Bit(s)	R/W	Default	Description
31	R/W	0	FIFO_DISABLE
30	R/W	0	PERIOD_SAMPLE_EN
29-13	R/W	0	ts_cntl_int
12-0	R/W	0	sar_bg_cntl

Table 13-150 SAR\_ADC\_REG12: 0x8c

Bit(s)	R/W	Default	Description
31-0	R/W	0	reserved

Table 13-151 SAR\_ADC\_REG13: 0x8d

Bit(s)	R/W	Default	Description
15-8	R/W	0	SARADC_RSV2
7-0	R/W	0	reserved

# 14 System Interface

## 14.1 JTAG

### 14.1.1 Overview

JTAG is an interface for internal test. The structure of SoC JTAG module is shown in the following diagram.

Figure 14-1 JTAG Structure

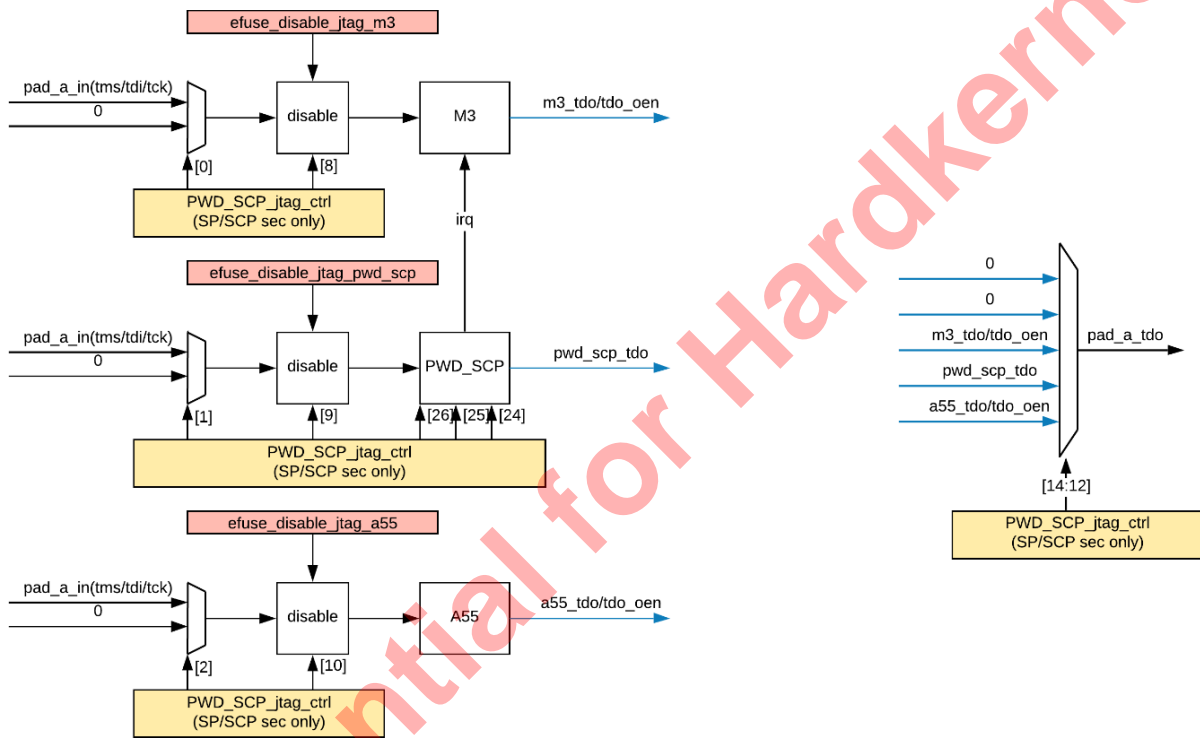

TGPF13

### 14.1.2 Register Description

Base address: 0xFF800000

Register address: 0xFF800000 + offset \* 4

Table 14-1 AO\_SEC\_JTAG\_SP\_CNTL 0xAC

Bit(s)	R/W	Default	Description
31	R	0	jrag_pwd_sp_data_valid; 1: finished write jtag_pwd_addr3;
30	R	0	jrag_pwd_sp_data_timeout; 1: jtag_pwd_sp_wd count greater threshold (time out);
26	R/W	0	jtag_pwd_sp_clr; 1: clear valid and irq status;

Bit(s)	R/W	Default	Description
25	R/W	0	jtag_pwd_sp_wd_resetr; 0: reset pwd_sp_wd, then no irq;
24	R/W	0	jtag_pwd_sp_en; 0: disable jtag_pwd_sp in/out; 1: enable jtag_pwd_sp in/out;
9	R/W	0	jtag_disable_pwd_sp_in; 0: enable; 1: disable pwd_sp_jtag_in;
8	R/W	0	jtag_disable_m4_in; 0: enable; 1: disable m4_jtag_in;
4	R/W	0	jtag_sel_force_m4_tdo_en_low; 0: tdo_en = m4_jtag_tdo_en; 1: tdo_en = 1'b0 (always output);
1	R/W	0	jtag_sel_pwd_sp_in; 0: pad_a; 1: pad_b;
0	R/W	0	jtag_sel_m4_in; 0: pad_a; 1: pad_b;

Table 14-2 AO\_SEC\_JTAG\_PWD\_SP\_0 0xAD

Bit(s)	R/W	Default	Description
31-0	R	0	jtag_pwd_sp received pwd[31:0]

Table 14-3 AO\_SEC\_JTAG\_PWD\_SP\_1 0xAE

Bit(s)	R/W	Default	Description
31-0	R	0	jtag_pwd_sp received pwd[63:32]

Table 14-4 AO\_SEC\_JTAG\_PWD\_SP\_2 0xAF

Bit(s)	R/W	Default	Description
31-0	R	0	jtag_pwd_sp received pwd[95:64]

Table 14-5 AO\_SEC\_JTAG\_PWD\_SP\_3 0xB0

Bit(s)	R/W	Default	Description
31-0	R	0	jtag_pwd_sp received pwd[127:96]

Table 14-6 AO\_SEC\_JTAG\_PWD\_SP\_CNTL 0xB1

Bit(s)	R/W	Default	Description
31:5	R/W	0	timeout threshold;
4	R/W	0	activity by tdo_en;



Bit(s)	R/W	Default	Description
			1: detect tdo activity and use it reset watchdog count;
3	R/W	0	activity by tck_en; 1: detect tck activity and use it reset watchdog count;
2	R/W	0	activity by tms_en; 1: detect tms activity and use it reset watchdog count;
1	R/W	0	activity by tdi_en; 1: detect tdi activity and use it reset watchdog count;
0	R/W	0	wd_timeout_en; 0: disable watchdog timeout; 1: enable watchdog timeout;

Table 14-7 AO\_SEC\_JTAG\_PWD\_SP\_ADDR0 0xB2

Bit(s)	R/W	Default	Description
31-0	R/W	0	addr0

Table 14-8 AO\_SEC\_JTAG\_PWD\_SP\_ADDR1 0xB3

Bit(s)	R/W	Default	Description
31-0	R/W	0	addr1

Table 14-9 AO\_SEC\_JTAG\_PWD\_SP\_ADDR2 0xB4

Bit(s)	R/W	Default	Description
31-0	R/W	0	addr2

Table 14-10 AO\_SEC\_JTAG\_PWD\_SP\_ADDR3 0xB5

Bit(s)	R/W	Default	Description
31-0	R/W	0	addr3

Table 14-11 AO\_SEC\_JTAG\_SCP\_CNTL 0xB6

Bit(s)	R/W	Default	Description
31	R	0	jrag_pwd_scp_data_valid; 1: finished write jtag_pwd_addr3;
30	R	0	jrag_pwd_scp_data_timeout; 1: jtag_pwd_sp_wd count greater threshold (time out);
26	R/W	0	jtag_pwd_scp_clr; 1: clear valid and irq status;
25	R/W	0	jtag_pwd_scp_wd_resetrn; 0: reset pwd_scp_wd, then no irq;
24	R/W	0	jtag_pwd_scp_en; 0: disable jtag_pwd_scp in/out; 1: enable jtag_pwd_scp in/out;

Bit(s)	R/W	Default	Description
18:16	R/W	0	jtag_pad_b_out_sel: 0: none; 1:m4; 2:jtag_pwd_sp; 3:m3; 4:jtag_pwd_scp; 5:A55
14:12	R/W	0	jtag_pad_a_out_sel: 0: none; 1:m4; 2:jtag_pwd_sp; 3:m3; 4:jtag_pwd_scp; 5:A55
10	R/W	0	jtag_disable_A55_in; 0: enable; 1: disable A55_jtag_in;
9	R/W	0	jtag_disable_pwd_scp_in; 0: enable; 1: disable pwd_scp_jtag_in;
8	R/W	0	jtag_disable_m3_in; 0: enable; 1: disable m3_jtag_in;
5	R/W	0	jtag_sel_force_A55_tdo_en_low; 0: tdo_en = A55_jtag_tdo_en; 1: tdo_en = 1'b0 (always output);
4	R/W	0	jtag_sel_force_m3_tdo_en_low; 0: tdo_en = m3_jtag_tdo_en; 1: tdo_en = 1'b0 (always output);
2	R/W	0	jtag_sel_A55_in; 0: pad_a; 1: pad_b;
1	R/W	0	jtag_sel_pwd_scp_in; 0: pad_a; 1: pad_b;
0	R/W	0	jtag_sel_m3_in; 0: pad_a; 1: pad_b;

Table 14-12 AO\_SEC\_JTAG\_PWD\_SCP\_0 0xB7

Bit(s)	R/W	Default	Description
31-0	R	0	jtag_pwd_scp received pwd[31:0]

Table 14-13 AO\_SEC\_JTAG\_PWD\_SCP\_1 0xB8

Bit(s)	R/W	Default	Description
31-0	R	0	jtag_pwd_scp received pwd[63:32]

**Table 14-14 AO\_SEC\_JTAG\_PWD\_SCP\_2 0xB9**

Bit(s)	R/W	Default	Description
31-0	R	0	jtag_pwd_scp received pwd[95:64]

**Table 14-15 AO\_SEC\_JTAG\_PWD\_SCP\_3 0xBA**

Bit(s)	R/W	Default	Description
31-0	R	0	jtag_pwd_scp received pwd[127:96]

**Table 14-16 AO\_SEC\_JTAG\_PWD\_SCP\_CNTL 0xBB**

Bit(s)	R/W	Default	Description
31:5	R/W	0	timeout threshold;
4	R/W	0	activity by tdo_en; 1: detect tdo activity and use it reset watchdog count;
3	R/W	0	activity by tck_en; 1: detect tck activity and use it reset watchdog count;
2	R/W	0	activity by tms_en; 1: detect tms activity and use it reset watchdog count;
1	R/W	0	activity by tdi_en; 1: detect tdi activity and use it reset watchdog count;
0	R/W	0	wd_timeout_en; 0: disable watchdog timeout; 1: enable watchdog timeout;

**Table 14-17 AO\_SEC\_JTAG\_PWD\_SCP\_ADDR0 0xBC**

Bit(s)	R/W	Default	Description
31-0	R/W	0	addr0

**Table 14-18 AO\_SEC\_JTAG\_PWD\_SCP\_ADDR1 0xBD**

Bit(s)	R/W	Default	Description
31-0	R/W	0	addr1

**Table 14-19 AO\_SEC\_JTAG\_PWD\_SCP\_ADDR2 0xBE**

Bit(s)	R/W	Default	Description
31-0	R/W	0	addr2

**Table 14-20 AO\_SEC\_JTAG\_PWD\_SCP\_ADDR3 0xBF**

Bit(s)	R/W	Default	Description
31-0	R/W	0	addr3

## 14.2 Temp Sensor

### 14.2.1 Overview

The SoC integrates 2 Temp Sensor, one is close to DDR, one is close to PLL (between CPU and GPU).

Each Temp Sensor are the same design.

- Capture temperature by programable tick;
- Store 16 temperature value;
- Can reset all chip if detect high temperature;
- Can generate IRQ by 8 threshold;

Figure 14-2 Temp Sensor

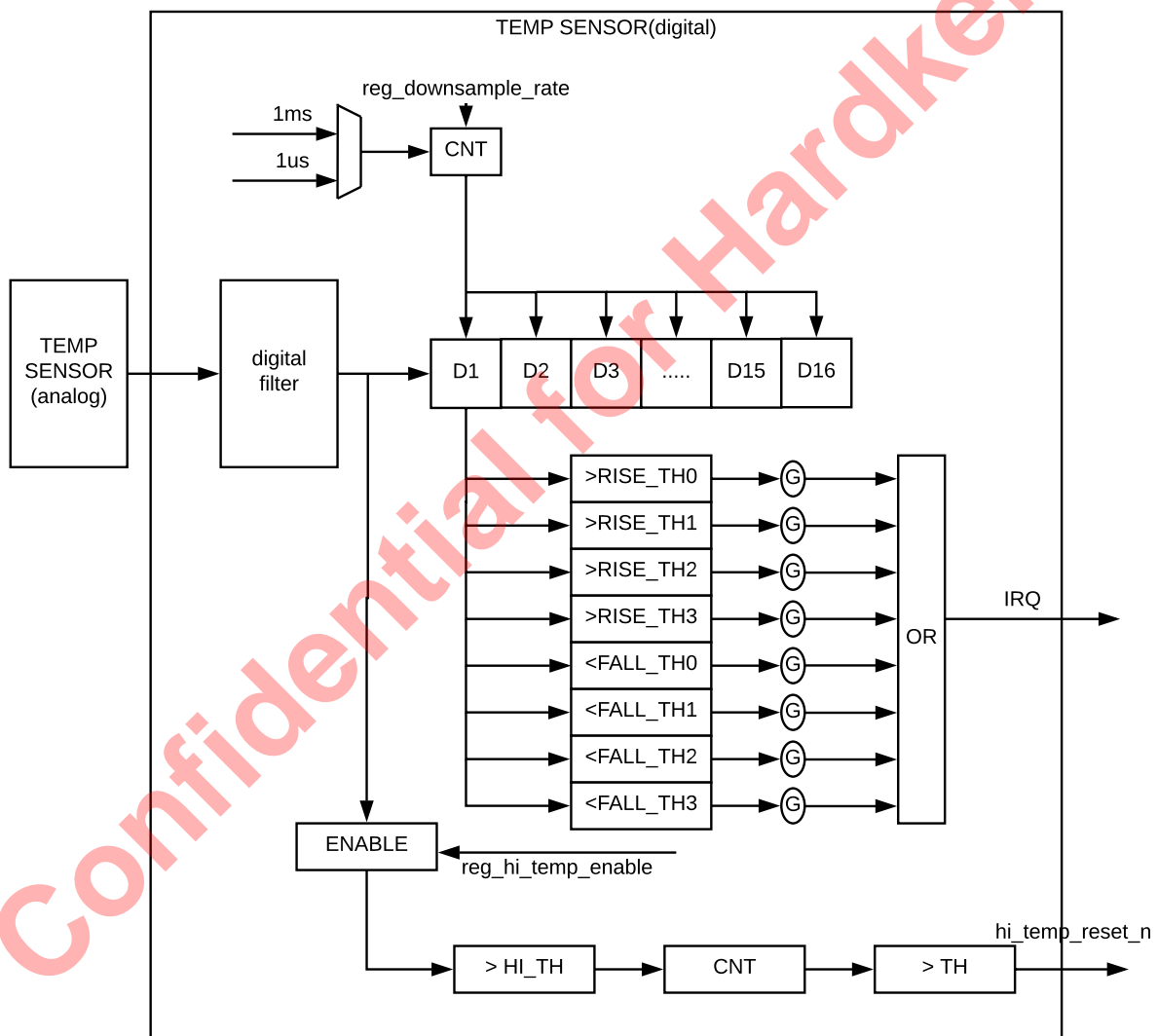

T02FC30

## 14.2.2 Register Description

### Temp Sensor PLL Registers

Base Address: 0xFF634800

Each register final address = module base address+ address \* 4

### Temp Sensor DDR Registers

Base Address: 0xFF634C00

Each register final address = module base address+ address \* 4

**Table 14-21 TS\_CFG\_REG1 0x001**

Bits	R/W	Default	Description
31	R/W	0x0000-0000	fall_th3_irq_en
30	R/W		fall_th2_irq_en
29	R/W		fall_th1_irq_en
28	R/W		fall_th0_irq_en
27	R/W		rise_th3_irq_en
26	R/W		rise_th2_irq_en
25	R/W		rise_th1_irq_en
24	R/W		rise_th0_irq_en
23	R/W		fall_th3_irq_stat_clr
22	R/W		fall_th2_irq_stat_clr
21	R/W		fall_th1_irq_stat_clr
20	R/W		fall_th0_irq_stat_clr
19	R/W		rise_th3_irq_stat_clr
18	R/W		rise_th2_irq_stat_clr
17	R/W		rise_th1_irq_stat_clr
16	R/W		rise_th0_irq_stat_clr
15	R/W		1: enable IRQ related function.
14	R/W		fast_mode: 0 : downsample unit = 1ms; 1: downsample unit = 1us;
13	R/W		clr_hi_temp_stat
12	R/W		ts_ana_rset_vbg reset vbg(set 0, if have error place set it plus 01000..)
11	R/W		ts_ana_rst_sd reset adc(set 0, if have error place set it plus 01000..)
10	R/W		ts_ana_en_vcm enable vcm (disable:0; enable:1)
9	R/W		ts_ana_en_vbg enable vbg (disable:0; enable: 1)

Bits	R/W	Default	Description
8:7	R/W		filter hcic mode 0: downsample rate = 128; 1: downsample rate = 256; 2/3: downsample rate = 512;
6	R/W		filter ts_out_ctrl; 1: add more delay for filter lock;
5	R/W		filter en(disable:0; enable:1)
4	R/W		ts_ana_en_iptat, useless.
3	R/W		Temp Sensor DEM enable. (disable:0; enable:1)
2:0	R/W		Bipolar bias current input control. recommend value : 3. ts_ana_ch_sel; 0: 8'b00000001; 1: 8'b00000011; 2: 8'b00000111; 3: 8'b00001111; 4: 8'b00011111; 5: 8'b00111111; 6: 8'b01111111; 7: 8'b11111111;

Table 14-22 TS\_CFG\_REG2 0x002

Bits	R/W	Default	Description
31	R/W	0x0000-0000	hi_temp_enable
30	R/W		reset_en, if = 0, will not reset all chip;
27:16	R/W		high temperature times, if continuous detect high temperature, then will reset all chip.
15:0	R/W		high temperature threshold, if temperature value > this th , mean detected once high temperature

Table 14-23 TS\_CFG\_REG3 0x03

Bits	R/W	Default	Description
31:16	R/W	0x0000-0000	
15:0	R/W		down_sample rate

Table 14-24 TS\_CFG\_REG4 0x04

Bits	R/W	Default	Description
23:12	R/W	0x0000-0000	rise_th0
11:0	R/W		rise_th1

Table 14-25 TS\_CFG\_REG5 0x05

Bits	R/W	Default	Description
23:12	R/W	0x0000-0000	rise_th2
11:0	R/W		rise_th3

Table 14-26 TS\_CFG\_REG6 0x06

Bits	R/W	Default	Description
23:12	R/W	0x0000-0000	fall_th0
11:0	R/W		fall_th1

Table 14-27 TS\_CFG\_REG7 0x07

Bits	R/W	Default	Description
23:12	R/W	0x0000-0000	fall_th2
11:0	R/W		fall_th3

Table 14-28 TS\_STAT0 0x10

Bits	R/W	Default	Description
31:18	R	0x0000-0000	detect_hi_temp_cnt
17	R		detected_hi_temp_stat
16	R		filter lock
15:0	R		filter out

Table 14-29 TS\_STAT1 0x11

Bits	R/W	Default	Description
31:9	R	0x0000-0000	
8	R		hi_temp_stat
7	R		fall_th3_irq
6	R		fall_th2_irq
5	R		fall_th1_irq
4	R		fall_th0_irq
3	R		rise_th3_irq
2	R		rise_th2_irq

Bits	R/W	Default	Description
1	R		rise_th1_irq
0	R		rise_th0_irq

Table 14-30 TS\_STAT2 0x12

Bits	R/W	Default	Description
31:16	R	0x0000-0000	temperature value D2
15:0	R		temperature value D1

Table 14-31 TS\_STAT3 0x13

Bits	R/W	Default	Description
31:16	R	0x0000-0000	temperature value D4
15:0	R		temperature value D3

Table 14-32 TS\_STAT4 0x14

Bits	R/W	Default	Description
31:16	R	0x0000-0000	temperature value D6
15:0	R		temperature value D5

Table 14-33 TS\_STAT5 0x15

Bits	R/W	Default	Description
31:16	R	0x0000-0000	temperature value D8
15:0	R		temperature value D7

Table 14-34 TS\_STAT6 0x16

Bits	R/W	Default	Description
31:16	R	0x0000-0000	temperature value D10
15:0	R		temperature value D9

Table 14-35 TS\_STAT7 0x17

Bits	R/W	Default	Description
31:16	R	0x0000-0000	temperature value D12
15:0	R		temperature value D11



**Table 14-36 TS\_STAT8 0x18**

Bits	R/W	Default	Description
31:16	R	0x0000-0000	temperature value D14
15:0	R		temperature value D13

**Table 14-37 TS\_STAT9 0x19**

Bits	R/W	Default	Description
31:16	R	0x0000-0000	temperature value D16
15:0	R		temperature value D15

Confidential for Hardkernel!