

AD9763 DAC Expansion Module User Guide

Get in touch with us!

Please feel free to send a mail to one of the mail IDs below or use the Contact Us page at <http://www.numato.com> to drop us a quick message.

Technical Help

Got technical questions? Please write to help@numato.com

Sales Team

Questions about making payments, volume discounts, academic/open source discounts, purchase orders and quotes? Please write to sales@numato.com

Webmaster

Questions/Suggestions about our website? Please write to webmaster@numato.com



Like us on Facebook! <https://www.facebook.com/numato>

Visit our blog <http://www.numato.cc> for news, updates and specials.

Mailing Address

Numato Systems Pvt Ltd
1st Floor, #56C Wipro Avenue
Phase 1 - Electronic City
Bangalore, KA-560100, India

* Mail orders, phone orders and direct pick up are not available at this time. Please visit our online store to place your order. Estimated shipping time to your address will be displayed in the shopping cart before checkout.



SOME RIGHTS RESERVED

You may use, modify or share this publication or part of thereof adhering to Creative Commons Attribution-ShareAlike 3.0 Unported (CC BY-SA 3.0) License.

See complete license text at <http://creativecommons.org/licenses/by-sa/3.0/>

All trademarks are property of their respective owners.

Introduction

The AD9763 DAC module features AD9763, a dual-port, high speed, 2-channel, 10-bit CMOS Digital to Analog converter. The AD9763 offer exceptional ac and dc performance while supporting update rates of up to 125 MSPS. This module is designed to be used with Numato Lab's FPGA/Micro-controller boards featuring a 2×6 pin Expansion connector. It can also be used with other boards and connector types by using manual wiring.

Applications

- Quadrature Modulation
- Data acquisition
- Digital Synthesis

Board features

- Three 2×6 expansion connectors
- 10-Bit dual transmit DAC
- 125 MSPS update rate
- Dual-port or interleaved data
- Power dissipation: 380 mW @ 5 V
- Dimension: 64mm x 62mm

How to use the module

The following section describes how to use this module.

Components/Tools required

Along with the module, you may need the items in the list below for easy and fast installation.

1. Any FPGA/Micro-controller board featuring a 2×6 pin Expansion connector (Manual wiring may be needed if using with boards that does not have 2×6 expansion connector)
2. DC Power supply (5-7)V.

Connection Diagram

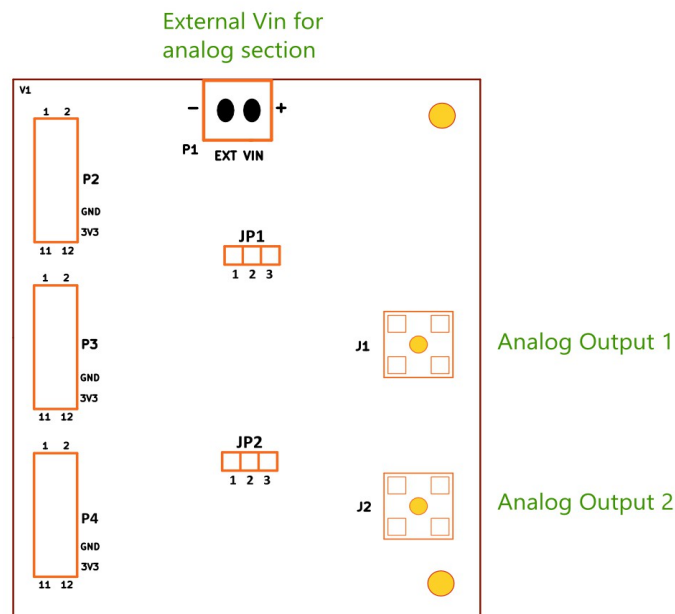

This diagram should be used as a reference only. For detailed information, see the schematics at the end of this document. Details of individual connectors are as below.

To use this module, directly attach the 2×6 male header on the expansion module to the 2×6 expansion connector on FPGA/Micro-controller development board. If 2×6 female headers are not available, manually make the connections as per the connection details below.

Connection Details

Header P2

Header Pin No.	Pin Details
1	INP8
2	INP9
3	INP6
4	INP7
5	INP4
6	INP5
7	INP2
8	INP3
9	DGND
10	DGND
11	VDD
12	VDD

Header P3

Header Pin No.	Pin Details
1	INP1
2	INP0
3	CLK2
4	CLK1
5	WRT1
6	WRT2
7	INP18
8	INP19
9	DGND
10	DGND
11	VDD
12	VDD

Header P4

Header Pin No.	Pin Details
1	INP16
2	INP17
3	INP14
4	INP15
5	INP12
6	INP13
7	INP10
8	INP11
9	DGND
10	DGND
11	VDD
12	VDD

For more information, refer the schematics at the end of this document.

Jumper Selection**Jumper P1**

Enables you to choose the modes of DAC, i.e. dual port and interleaved mode. Place the jumper in position 1-2 to select dual port mode and position 2-3 to select interleaved mode.

Jumper P2

Enables you to choose the Gain control modes of DAC, i.e. independent and master/slave mode. Place the jumper in position 1-2 to select master/slave mode and position 2-3 to select independent mode.

Technical Specifications

Parameter *	Value	Unit
Basic Specifications		
Conversion resolution	10	Bits
Max Sample rate	125	MSPS
SFDR to Nyquist	75 dB @ 5MHz	
External Power Supply		
DC Power Supply (V _D)	3.3	V
Digital Input Voltage	-0.3 to DVDD + 0.3	V

* All parameters considered nominal. Numato Systems Pvt Ltd reserve the right to modify products without notice. For more information refer [AD9763 Data Sheet](#)

Physical Dimensions

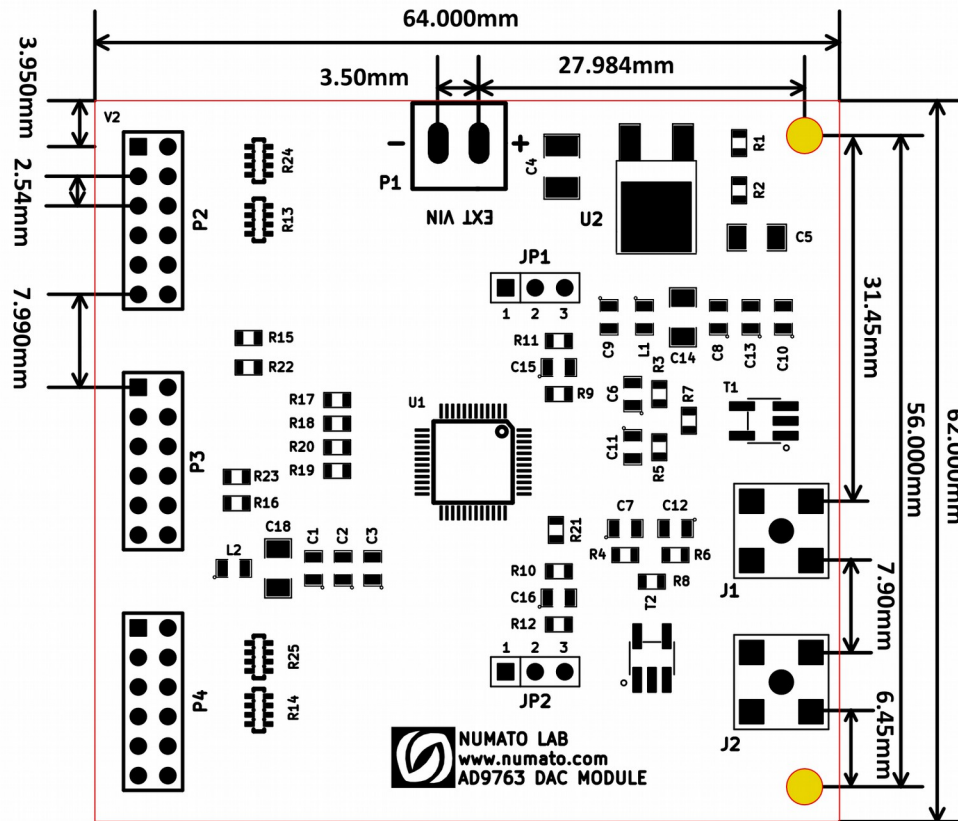

L x W x H : 64.00 mm x 62.00 mm x 14 mm

Mechanical Hole Diameter : 3.2 mm

Schematics

See next page.

