

## Low voltage 16-bit constant current LED sink driver

### Features

- Low voltage power supply down to 3 V
- 16 constant current output channels
- Adjustable output current through external resistor
- Serial data IN/parallel data OUT
- Can be driven by a 3.3 V microcontroller
- Output current: 5-100 mA
- Max clock frequency 30 MHz
- ESD protection 2 kV HBM, 200 V MM

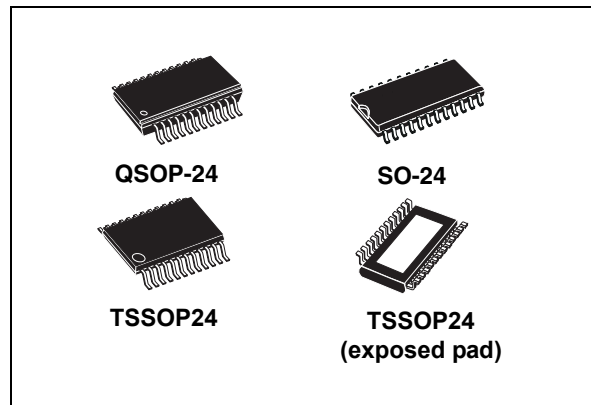

### Description

The STP16CP05 is a monolithic, low voltage, low current power 16-bit shift register designed for LED panel displays. The STP16CP05 contains a 16-bit serial-in, parallel-out shift register that feeds a 16-bit, D-type storage register. In the output stage, sixteen regulated current sources provide from 5 mA to 100 mA constant current to drive the LEDs.

The STP16CP05 guarantees a 20 V output driving capability, allowing users to connect more LEDs in series. The high clock frequency, 30 MHz, makes the device suitable for high data rate transmission. The 3.3 V voltage supply is useful in applications that interface with a 3.3 V micro controller.

The output current setup time is 40 ns (typ), thus improving the system performance.

The LEDs' brightness can be controlled by using an external resistor to adjust the STP16CP05 output current.

**Table 1. Device summary**

Order codes	Package	Packaging
STP16CP05MTR	SO-24	1000 parts per reel
STP16CP05TTR	TSSOP24	2500 parts per reel
STP16CP05XTTR	TSSOP24 exposed pad	2500 parts per reel
STP16CP05PTR	QSOP-24	2500 parts per reel

# 1 Summary description

**Table 2. Typical current accuracy**

Output voltage	Current accuracy		Output current	V <sub>DD</sub>	Temperature
	Between bits	Between ICs			
≥ 1.3 V	±1.5%	±5%	≥ 20 to 100 mA	3.3 V to 5 V	25 °C

## 1.1 Pin connection and description

**Figure 2. Pin connection**

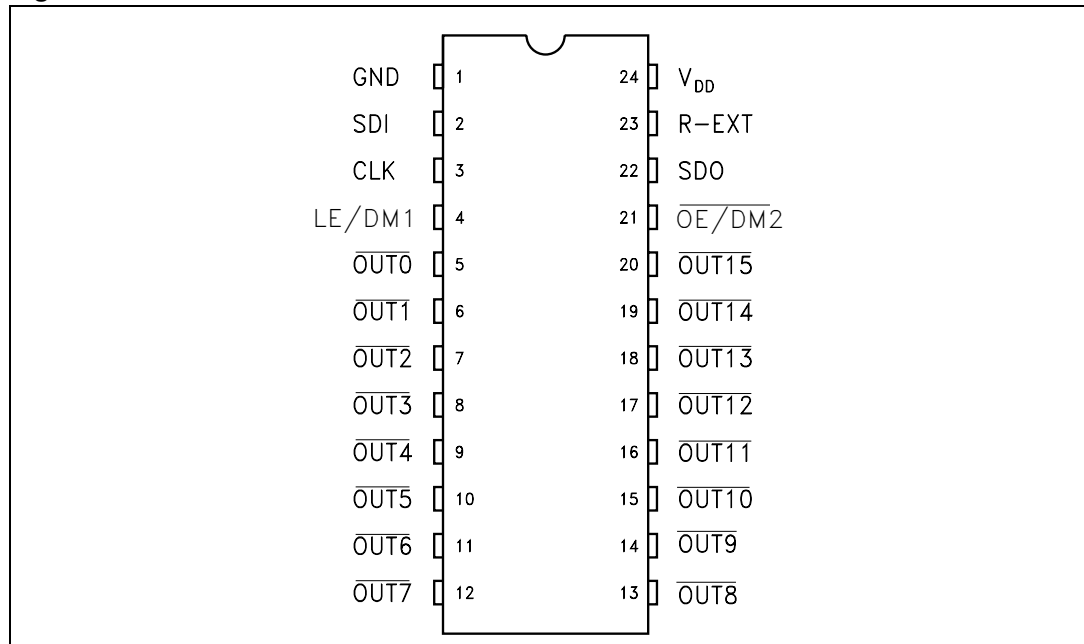

*Note:* The exposed pad is electrically not connected

**Table 3. Pin description**

Pin N°	Symbol	Name and function
1	GND	Ground terminal
2	SDI	Serial data input terminal
3	CLK	Clock input terminal
4	LE/DM1	Latch input terminal
5-20	OUT 0-15	Output terminal
21	$\overline{\text{OE/DM2}}$	Input terminal of output enable (active low)
22	SDO	Serial data out terminal
23	R-EXT	Input terminal of an external resistor for constant current programming
24	V <sub>DD</sub>	Supply voltage terminal

## 2 Electrical ratings

### 2.1 Absolute maximum ratings

Stressing the device above the rating listed in the “absolute maximum ratings” table may cause permanent damage to the device. These are stress ratings only and operation of the device at these or any other conditions above those indicated in the operating sections of this specification is not implied. Exposure to absolute maximum rating conditions for extended periods may affect device reliability.

**Table 4. Absolute maximum ratings**

Symbol	Parameter	Value	Unit
$V_{DD}$	Supply voltage	0 to 7	V
$V_O$	Output voltage	-0.5 to 20	V
$I_O$	Output current	100	mA
$V_I$	Input voltage	-0.4 to $V_{DD}$	V
$I_{GND}$	GND terminal current	1600	mA
$f_{CLK}$	Clock frequency	50	MHz
$T_J$	Junction temperature range	-40 to +170	°C

### 2.2 Thermal data

**Table 5. Thermal data**

Symbol	Parameter	Value	Unit	
$T_{OPR}$	Operating temperature range	-40 to +125	°C	
$T_{STG}$	Storage temperature range	-55 to +150	°C	
$R_{thJA}$	Thermal resistance junction-ambient <sup>(1)</sup>	SO-24	60	°C/W
		TSSOP24	85	°C/W
		TSSOP24 <sup>(2)</sup> exposed pad	37.5	°C/W
		QSOP-24	72	°C/W

1. According with Jedec 51-7

2. The exposed pad should be soldered directly to the PCB to realize the thermal benefits.

## 2.3 Recommended operating conditions

$T_A = 25\text{ }^\circ\text{C}$

**Table 6. Recommended operating conditions**

Symbol	Parameter	Test conditions	Min.	Typ.	Max.	Unit
$V_{DD}$	Supply voltage		3.0	-	5.5	V
$V_O$	Output voltage			-	20	V
$I_O$	Output current	OUTn	3	-	100	mA
$I_{OH}$	Output current	SERIAL-OUT		-	+1	mA
$I_{OL}$	Output current	SERIAL-OUT		-	-1	mA
$V_{IH}$	Input voltage		$0.7V_{DD}$	-	$V_{DD}$	V
$V_{IL}$	Input voltage		-0.3	-	$0.3V_{DD}$	V
$t_{wLAT}$	LE/DM1 pulse width	$V_{DD} = 3.3\text{ V to }5.0\text{ V}$	6	-		ns
$t_{wCLK}$	CLK pulse width		8	-		ns
$t_{wEN}$	$\overline{OE}/\overline{DM2}$ pulse width		100	-		ns
$t_{SETUP(D)}$	Setup time for DATA		5	-		ns
$t_{HOLD(D)}$	Hold time for DATA		3	-		ns
$t_{SETUP(L)}$	Setup time for LATCH		18	-		ns
$f_{CLK}$	Clock frequency		Cascade operation <sup>(1)</sup> $V_{DD} = 5\text{ V}$		-	30

1. If the device is connected in cascade, it may not be possible to achieve the maximum data transfer. Please consider the timings carefully.

### 3 Electrical characteristics

$V_{DD} = 3.3 \text{ V to } 5 \text{ V}$ ,  $T_A = 25 \text{ }^\circ\text{C}$ , unless otherwise specified

**Table 7. Electrical characteristics**

Symbol	Parameter	Test conditions	Min.	Typ.	Max.	Unit
$V_{IH}$	Input voltage high level		$0.7V_{DD}$		$V_{DD}$	V
$V_{IL}$	Input voltage low level		GND		$0.3V_{DD}$	V
$I_{OH}$	Output leakage current	$V_{OH} = 20 \text{ V}$			1	$\mu\text{A}$
$V_{OL}$	Output voltage (Serial-OUT)	$I_{OL} = 1 \text{ mA}$			0.4	V
$V_{OH}$	Output voltage (Serial-OUT)	$I_{OH} = -1 \text{ mA}$	$V_{DD}-0.4\text{V}$			V
$I_{OL1}$	Output current	$V_O = 0.3 \text{ V}$ , $R_{ext} = 4.2 \text{ k}\Omega$	4.25	5	5.75	mA
$I_{OL2}$		$V_O = 0.3 \text{ V}$ , $R_{ext} = 1 \text{ k}\Omega$	19	20	21	
$I_{OL3}$		$V_O = 1.3 \text{ V}$ , $R_{ext} = 200 \Omega$	96	100	104	
$\Delta I_{OL1}$	Output current error between bit (All Output ON)	$V_O = 0.3 \text{ V}$ , $R_{ext} = 4.2 \text{ k}\Omega$		$\pm 5$	$\pm 8$	%
$\Delta I_{OL2}$		$V_O = 0.3 \text{ V}$ , $R_{ext} = 1 \text{ k}\Omega$		$\pm 1.5$	$\pm 3$	
$\Delta I_{OL3}$		$V_O = 1.3 \text{ V}$ , $R_{ext} = 200 \Omega$		$\pm 1.2$	$\pm 3$	
$R_{SIN(up)}$	Pull-up resistor		150	300	600	$\text{k}\Omega$
$R_{SIN(down)}$	Pull-down resistor		100	200	400	$\text{k}\Omega$
$I_{DD(OFF1)}$	Supply current (OFF)	$R_{EXT} = 1 \text{ k}\Omega$ OUT 0 to 15 = OFF		4		mA
$I_{DD(OFF2)}$		$R_{EXT} = 250\Omega$ OUT 0 to 15 = OFF		11.2		
$I_{DD(ON1)}$	Supply current (ON)	$R_{EXT} = 1 \text{ k}\Omega$ OUT 0 to 15 = ON		4.5		
$I_{DD(ON2)}$		$R_{EXT} = 250\Omega$ OUT 0 to 15 = ON		11.7		
Thermal	Thermal protection			170		$^\circ\text{C}$

V<sub>DD</sub> = 5 V, T = 25 °C, unless otherwise specified

**Table 8. Switching characteristics**

Symbol	Parameter	Test conditions	Min.	Typ.	Max.	Unit	
t <sub>PLH1</sub>	Propagation delay time, CLK-OUT <sub>n</sub> , LE/DM1 = H, OE/DM2 = L	V <sub>IH</sub> = V <sub>DD</sub> V <sub>IL</sub> = GND I <sub>O</sub> = 20 mA R <sub>EXT</sub> = 1 KΩ C <sub>L</sub> = 10 pF V <sub>L</sub> = 3.0 V R <sub>L</sub> = 60 Ω	V <sub>DD</sub> = 3.3 V	-	45	74	ns
			V <sub>DD</sub> = 5 V	-	24	38	
t <sub>PLH2</sub>	Propagation delay time, LE/DM1-OUT <sub>n</sub> , OE/DM2 = L		V <sub>DD</sub> = 3.3 V	-	48	77	ns
			V <sub>DD</sub> = 5 V	-	27	46	
t <sub>PLH3</sub>	Propagation delay time, OE/DM2-OUT <sub>n</sub> , LE/DM1 = H		V <sub>DD</sub> = 3.3 V	-	75	128	ns
			V <sub>DD</sub> = 5 V	-	43	64	
t <sub>PLH</sub>	Propagation delay time, CLK-SDO		V <sub>DD</sub> = 3.3 V	-	19	28	ns
			V <sub>DD</sub> = 5 V	-	11	16.5	
t <sub>PHL1</sub>	Propagation delay time, CLK-OUT <sub>n</sub> , LE/DM1 = H, OE/DM2 = L		V <sub>DD</sub> = 3.3 V	-	15	23	ns
			V <sub>DD</sub> = 5 V	-	10	14	
t <sub>PHL2</sub>	Propagation delay time, LE/DM1-OUT <sub>n</sub> , OE/DM2 = L		V <sub>DD</sub> = 3.3 V	-	13	18.5	ns
			V <sub>DD</sub> = 5 V	-	9	12	
t <sub>PHL3</sub>	Propagation delay time, OE/DM2-OUT <sub>n</sub> , LE/DM1 = H		V <sub>DD</sub> = 3.3 V	-	17	24.5	ns
			V <sub>DD</sub> = 5 V	-	14	19.5	
t <sub>PHL</sub>	Propagation delay time, CLK-SDO	V <sub>DD</sub> = 3.3 V	-	23	35	ns	
		V <sub>DD</sub> = 5 V	-	14	21		
t <sub>ON</sub>	Output rise time 10~90% of voltage waveform	V <sub>DD</sub> = 3.3 V	-	35	68	ns	
		V <sub>DD</sub> = 5 V	-	21	31.5		
t <sub>OFF</sub>	Output fall time 90~10% of voltage waveform	V <sub>DD</sub> = 3.3 V	-	10.5	15	ns	
		V <sub>DD</sub> = 5 V	-	11	15.5		
t <sub>r</sub>	CLK rise time <sup>(1)</sup>		-		5000	ns	
t <sub>f</sub>	CLK fall time <sup>(1)</sup>		-		5000	ns	

1. In order to achieve high cascade data transfer, please consider tr/tf timings carefully.

## 4 Equivalent circuit and outputs

Figure 3.  $\overline{\text{OE}}/\text{DM2}$  terminal

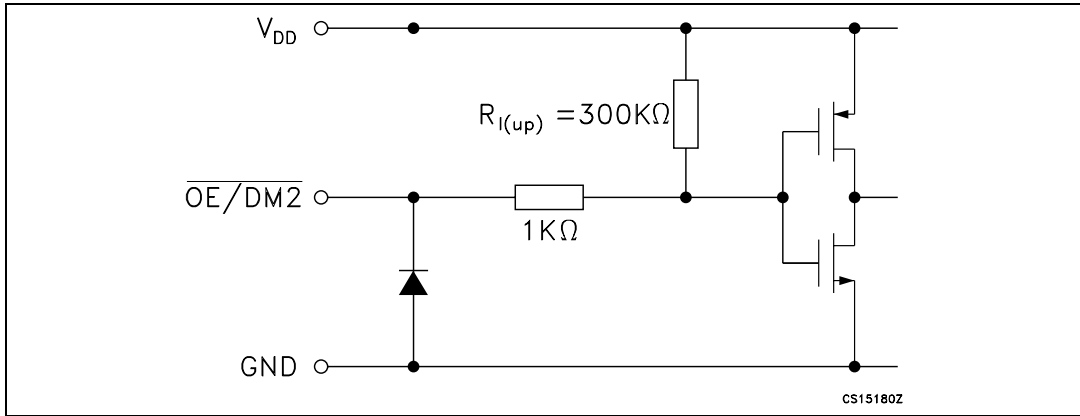

Figure 4.  $\text{LE}/\text{DM1}$  terminal

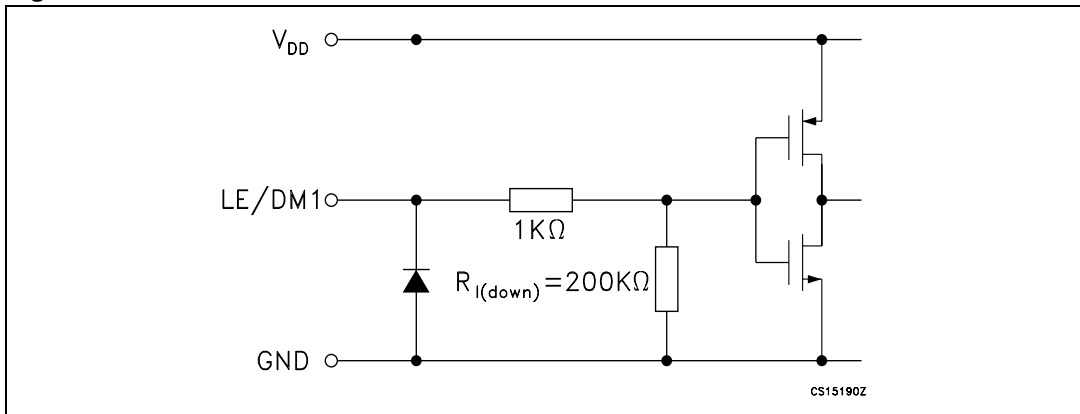

Figure 5.  $\text{CLK}, \text{SDI}$  terminal

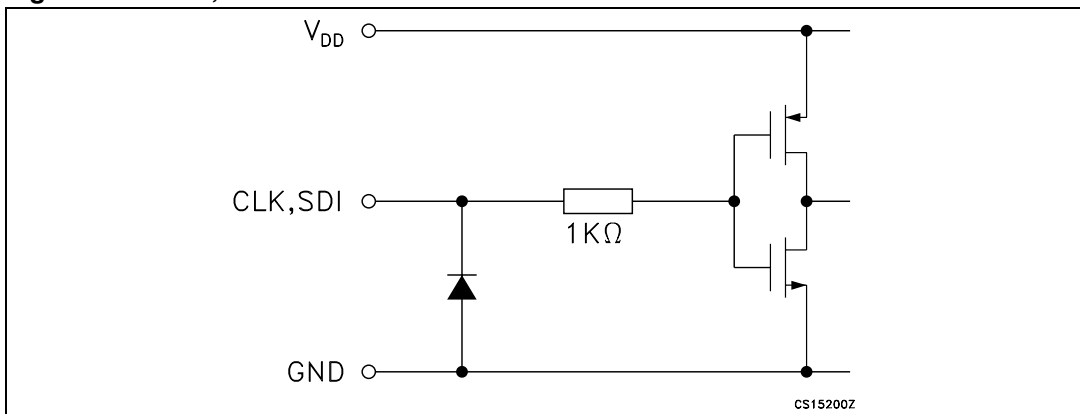

Figure 6. SDO terminal

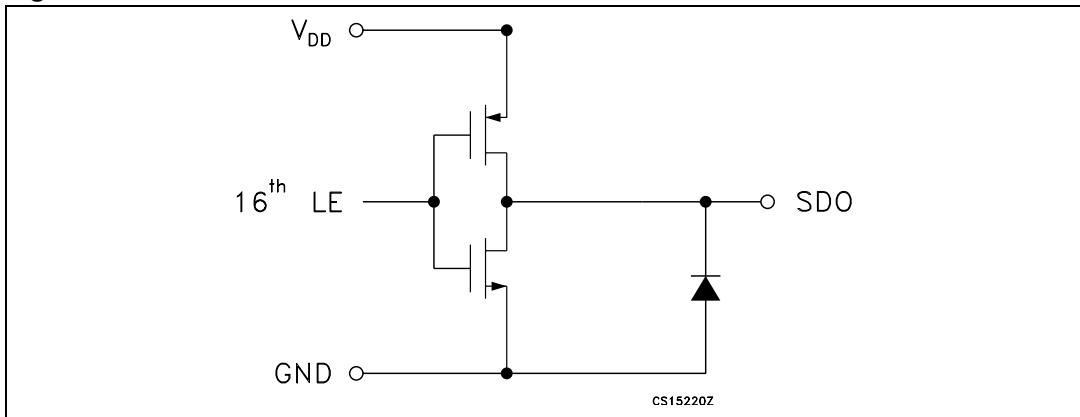
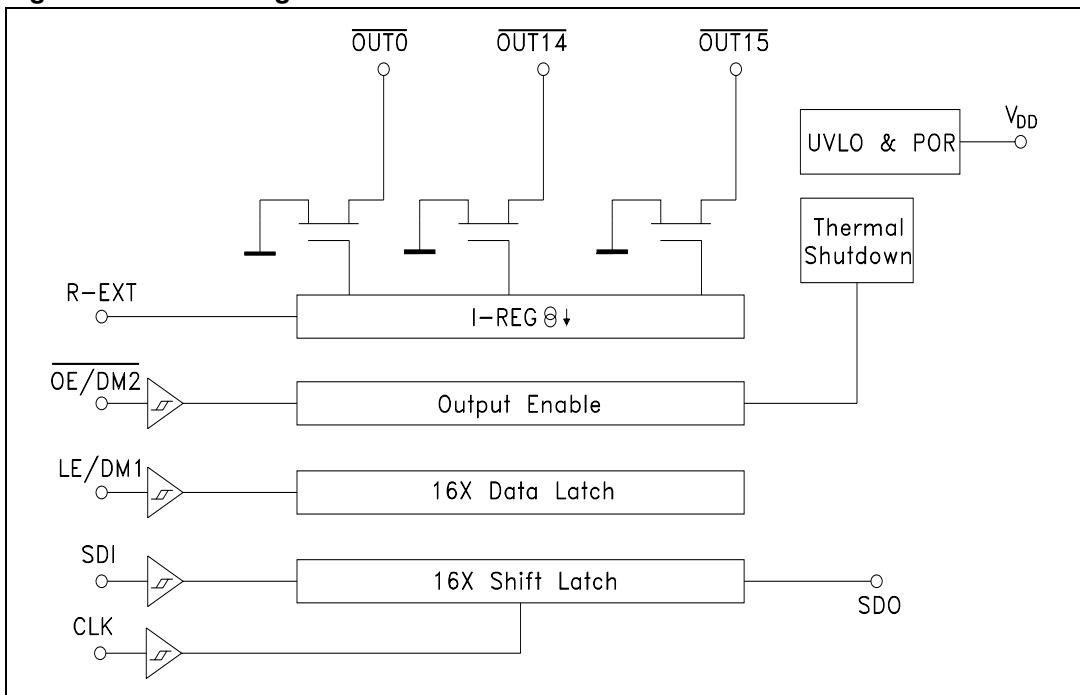

Figure 7. Block diagram





# 5 Timing diagrams

**Table 9. Truth table**

CLOCK	LE/DM1	OE/DM2	Serial-IN	OUT0 ..... OUT7 ..... OUT15	SDO
	H	L	Dn	Dn ..... Dn - 7 ..... Dn -15	Dn - 15
	L	L	Dn + 1	No change	Dn - 14
	H	L	Dn + 2	Dn + 2 ..... Dn - 5 ..... Dn -13	Dn - 13
	X	L	Dn + 3	Dn + 2 ..... Dn - 5 ..... Dn -13	Dn - 13
	X	H	Dn + 3	OFF	Dn - 13

Note:  $OUTn = ON$  when  $Dn = H$   $OUTn = OFF$  when  $Dn = L$

**Figure 8. Timing diagram**

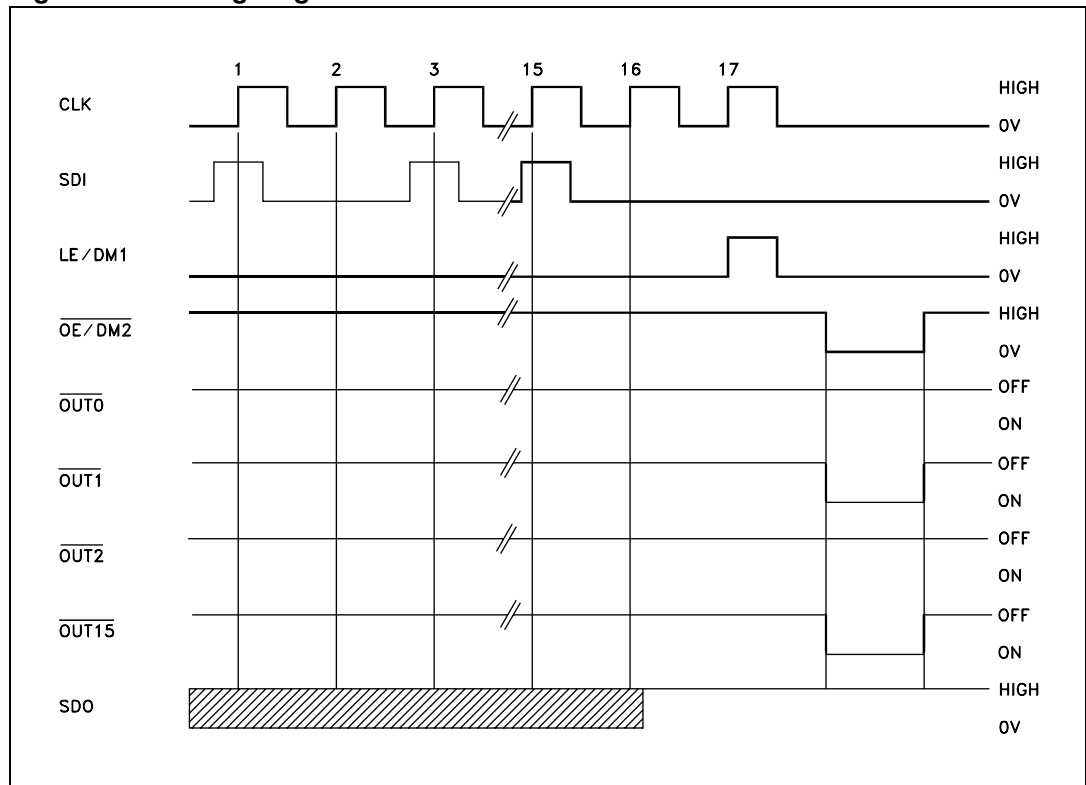

- Note:
- 1 Latch and Output Enable are level sensitive and ARE NOT synchronized with rising-or-falling edge of CLK signal.
  - 2 When LE/DM1 terminal is low level, the latch circuits hold previous set of data
  - 3 When LE/DM1 terminal is high level, the latch circuits refresh new set of data from SDI chain.
  - 4 When OE/DM2 terminal is low level, the output terminals - Out0 to Out15 respond to data in the latch circuits, either '1' for ON or '0' for OFF
  - 5 When OE/DM2 terminal is at high level, all output terminals will be switched OFF.

Figure 9. Clock, serial-in, serial-out

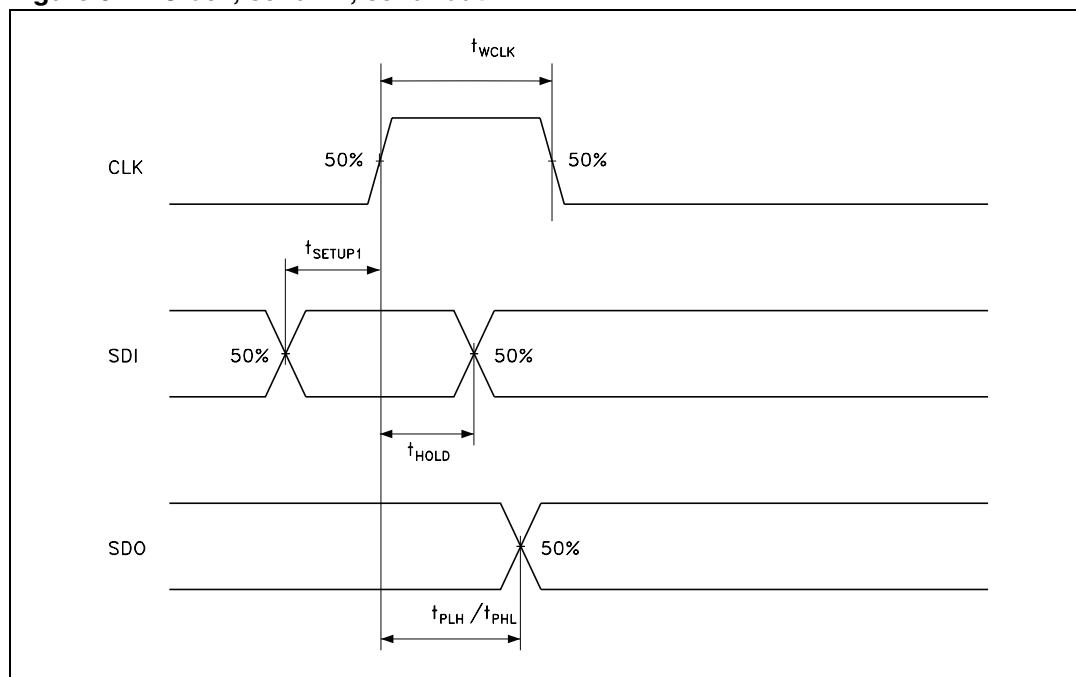

Figure 10. Clock, serial-in, latch, enable, outputs

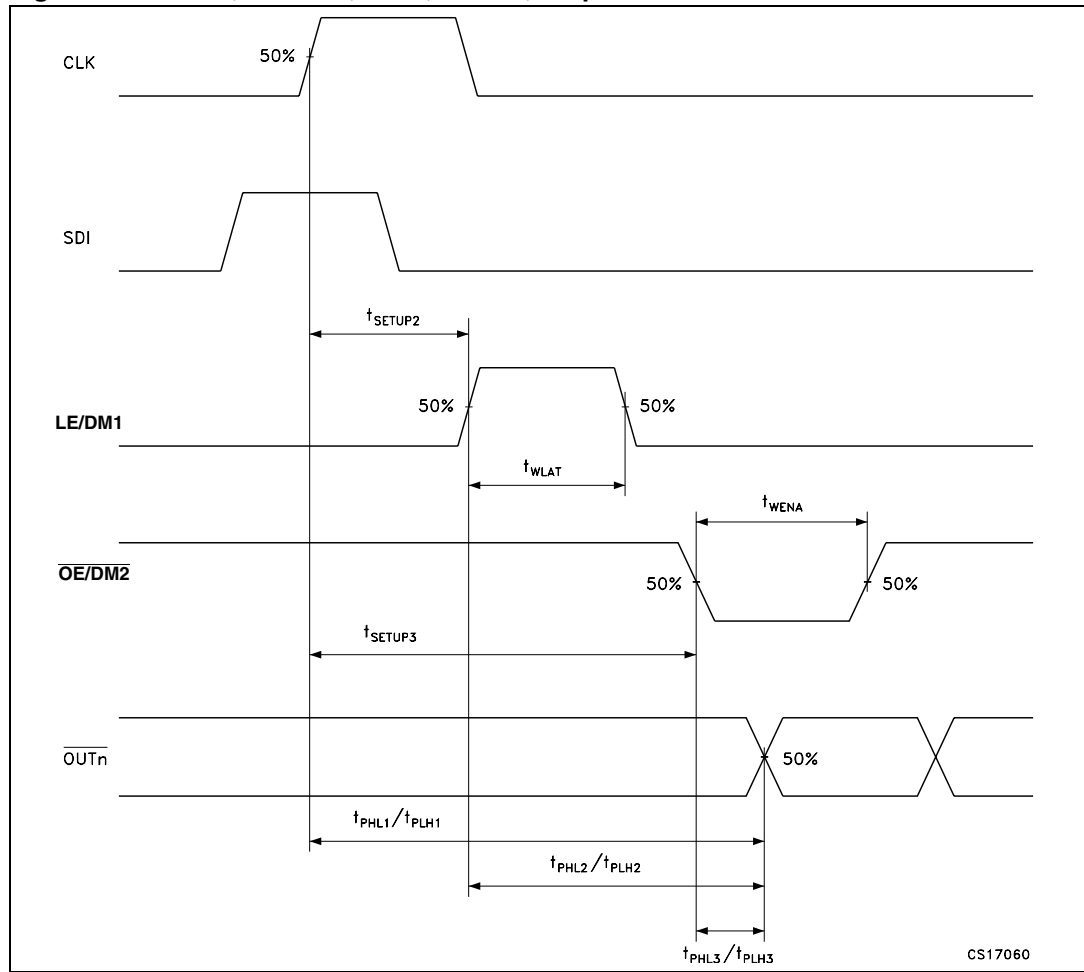
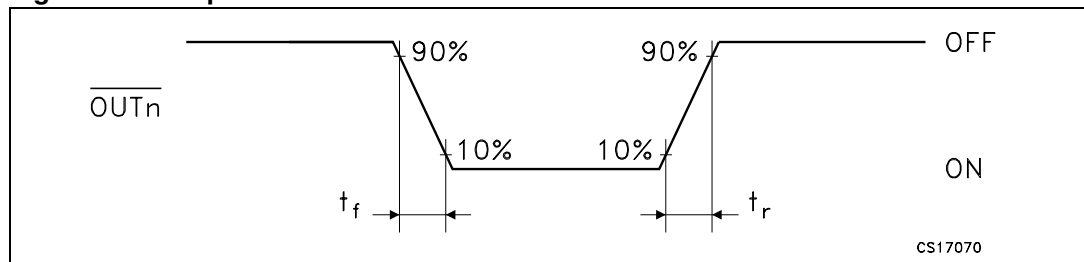

Figure 11. Outputs



## 6 Typical characteristics

Figure 12. Output current- $R_{EXT}$  resistor

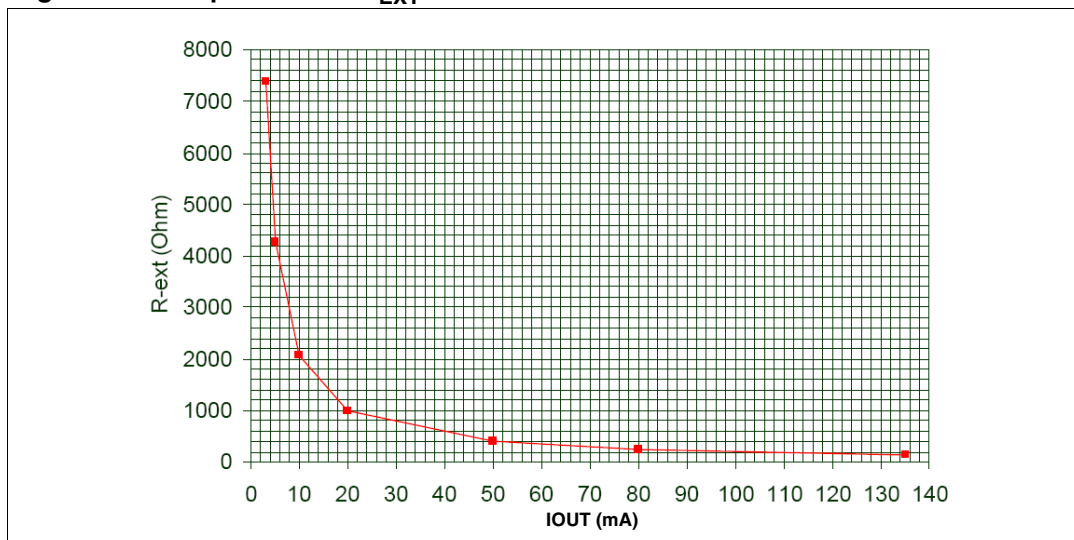

Table 10. Output current- $R_{EXT}$  resistor

R-EXT ( $\Omega$ )	Output current (mA)
7370	3
4270	5
2056	10
1006	20
382	50
251	80
200	100

Figure 13. Output current vs  $\pm \Delta I_{OL}(\%)$   $T_A = 25\text{ }^\circ\text{C}$

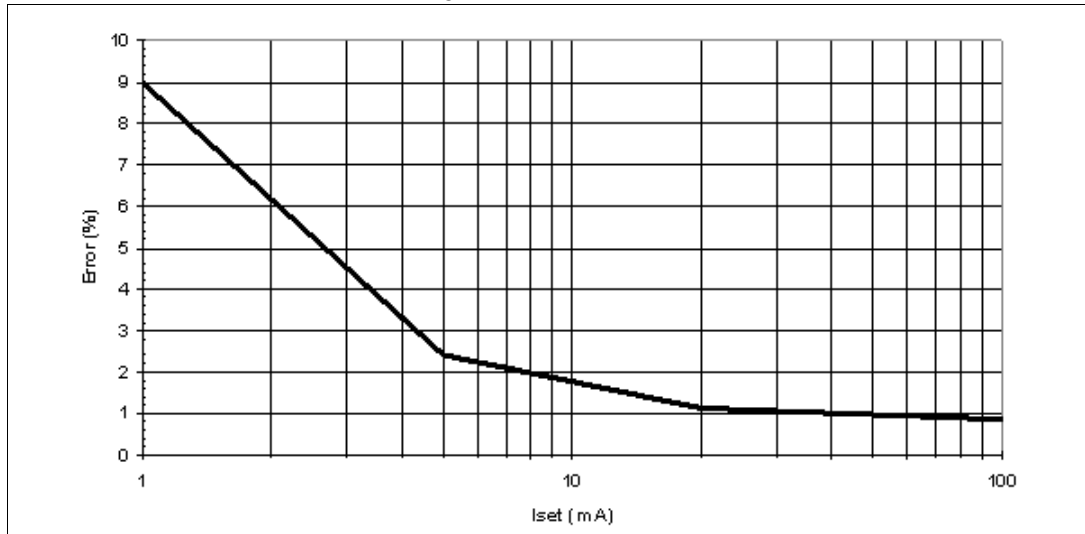

Figure 14.  $I_{SET}$  vs drop out voltage ( $V_{drop}$ )  $T_A = 25\text{ }^\circ\text{C}$

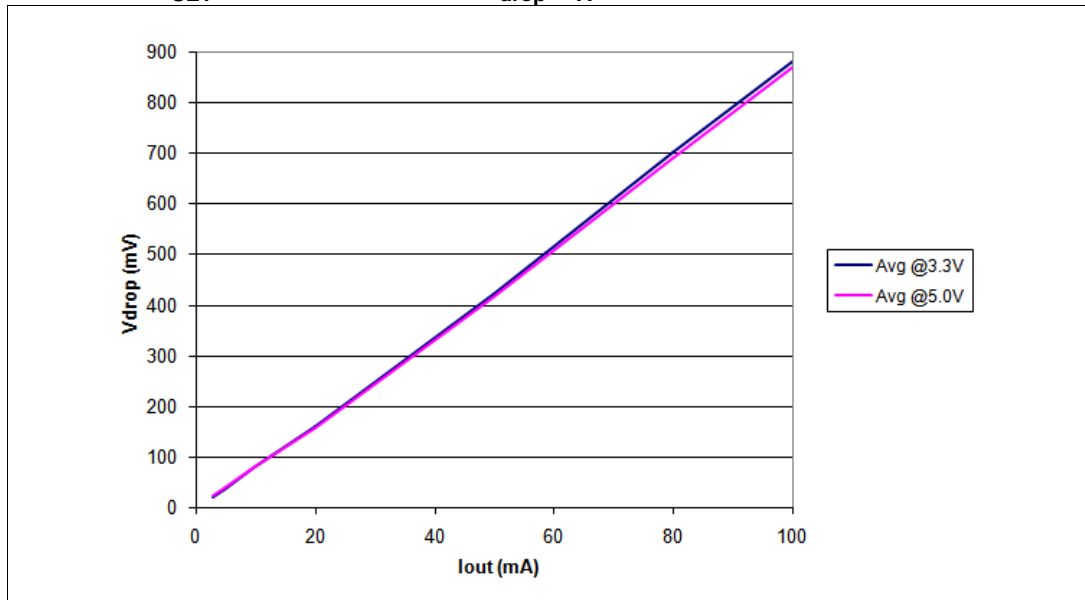
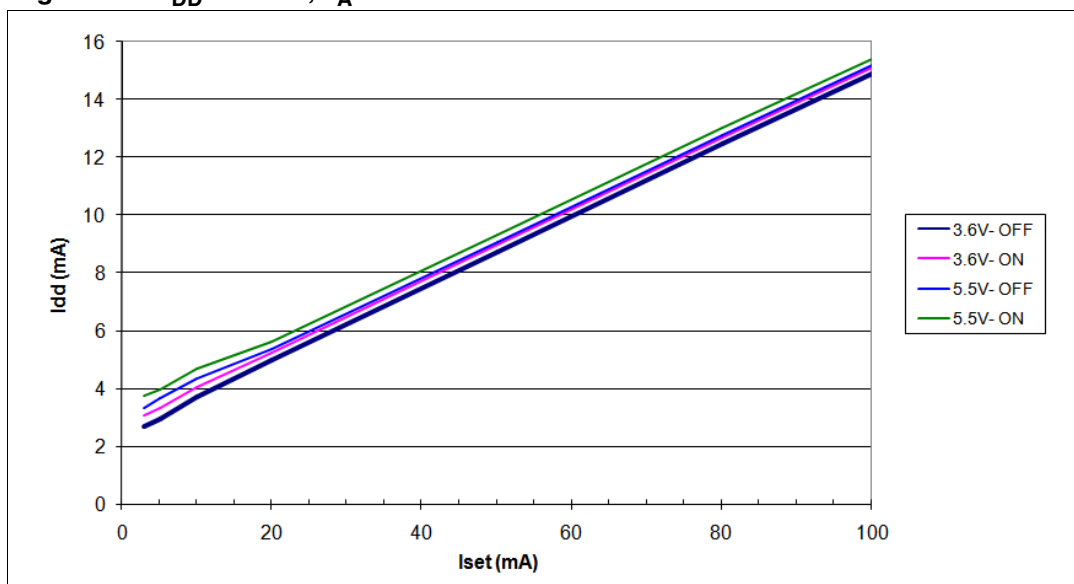

Table 11.  $I_{SET}$  vs drop out voltage ( $V_{drop}$ )

Iout (mA)	Avg @3.3 V	Avg @5.0 V
3	20	22
5	37	40
10	79	79
20	160	158
50	422	415
80	700	690
100	880	870

Figure 15.  $I_{DD}$  ON/OFF,  $T_A = 25\text{ }^\circ\text{C}$



# 7 Test circuit

Figure 16. DC characteristic

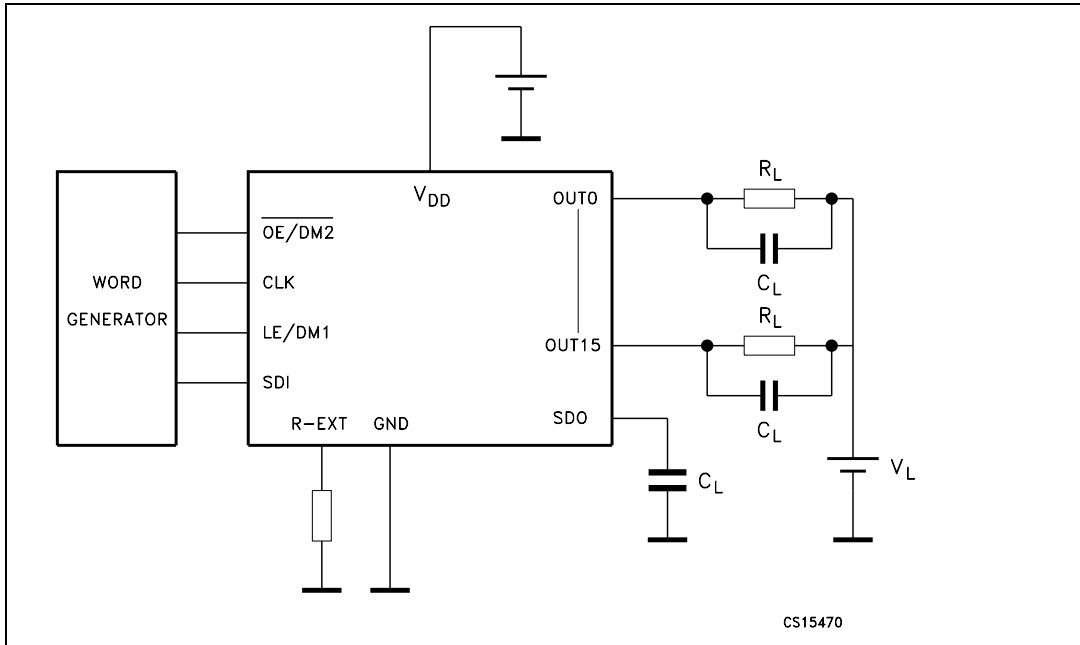

Figure 17. AC characteristic

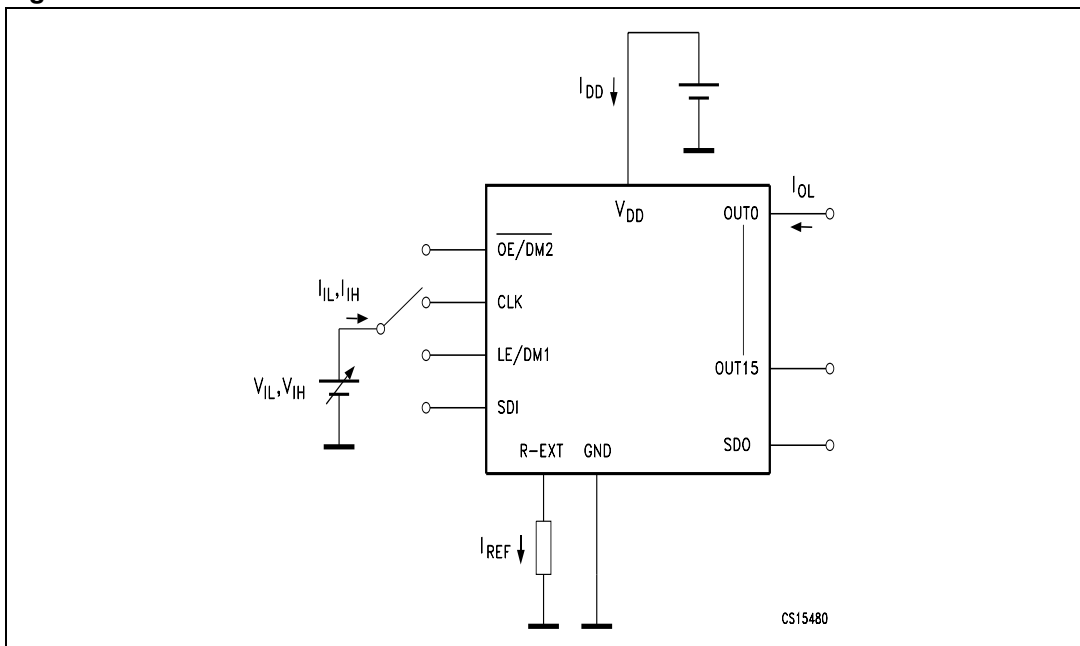
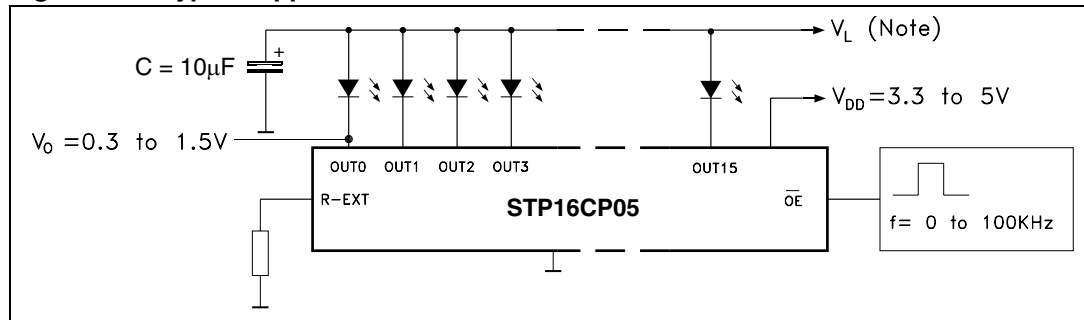

Figure 18. Typical application schematic



Note:

$V_L$  will be determined by the  $V_F$  of the LEDs

Test condition: Temp. = 25 °C,  $V_{DD}$  = 3.0 V,  $V_{IN}$  =  $V_{DD}$ ,  $C_L$  = 10 pF, Freq. = 1 MHz,  
 Ch1 =  $\overline{OE}/DM2$ , Ch2 = SDI, Ch3 =  $V_{OUT}$ , Ch4 =  $I_{OUT}$

Figure 19. Turn ON output current setup

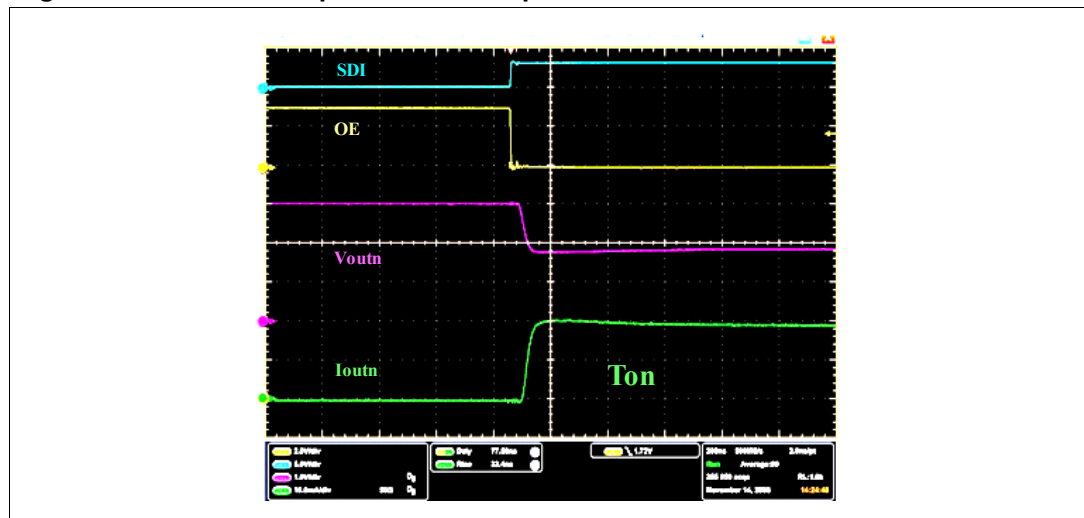
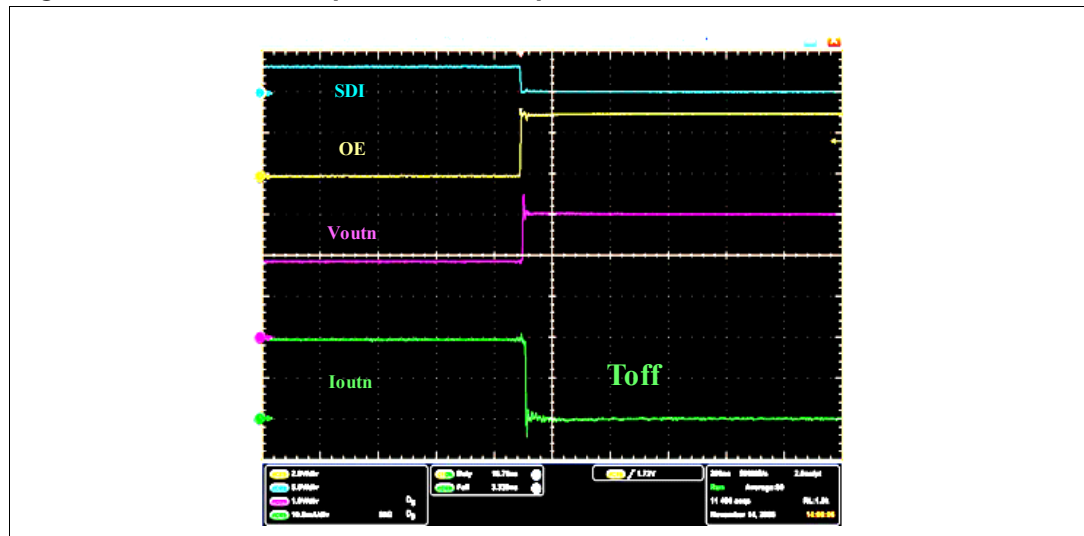

Figure 20. Turn OFF output current setup





## 8 Package mechanical data

In order to meet environmental requirements, ST offers these devices in different grades of ECOPACK<sup>®</sup> packages, depending on their level of environmental compliance. ECOPACK<sup>®</sup> specifications, grade definitions and product status are available at: [www.st.com](http://www.st.com). ECOPACK<sup>®</sup> is an ST trademark.

**Table 12. QSOP-24 mechanical data**

Dim.	mm.			inch		
	Min.	Typ.	Max.	Min.	Typ.	Max.
A	1.54	1.62	1.73	0.061	0.064	0.068
A1	0.1	0.15	0.25	0.004	0.006	0.010
A2		1.47			0.058	
b	0.31	0.2		0.012	0.008	
c	0.254	0.17		0.010	0.007	
D	8.56	8.66	8.76	0.337	0.341	0.345
E	5.8	6	6.2	0.228	0.236	0.244
E1	3.8	3.91	4.01	0.150	0.154	0.158
e		0.635			0.025	
L	0.4	0.635	0.89	0.016	0.025	0.035
h	0.25	0.33	0.41	0.010	0.013	0.016
<	8°	0°				

Figure 21. QSOP-24 package dimensions

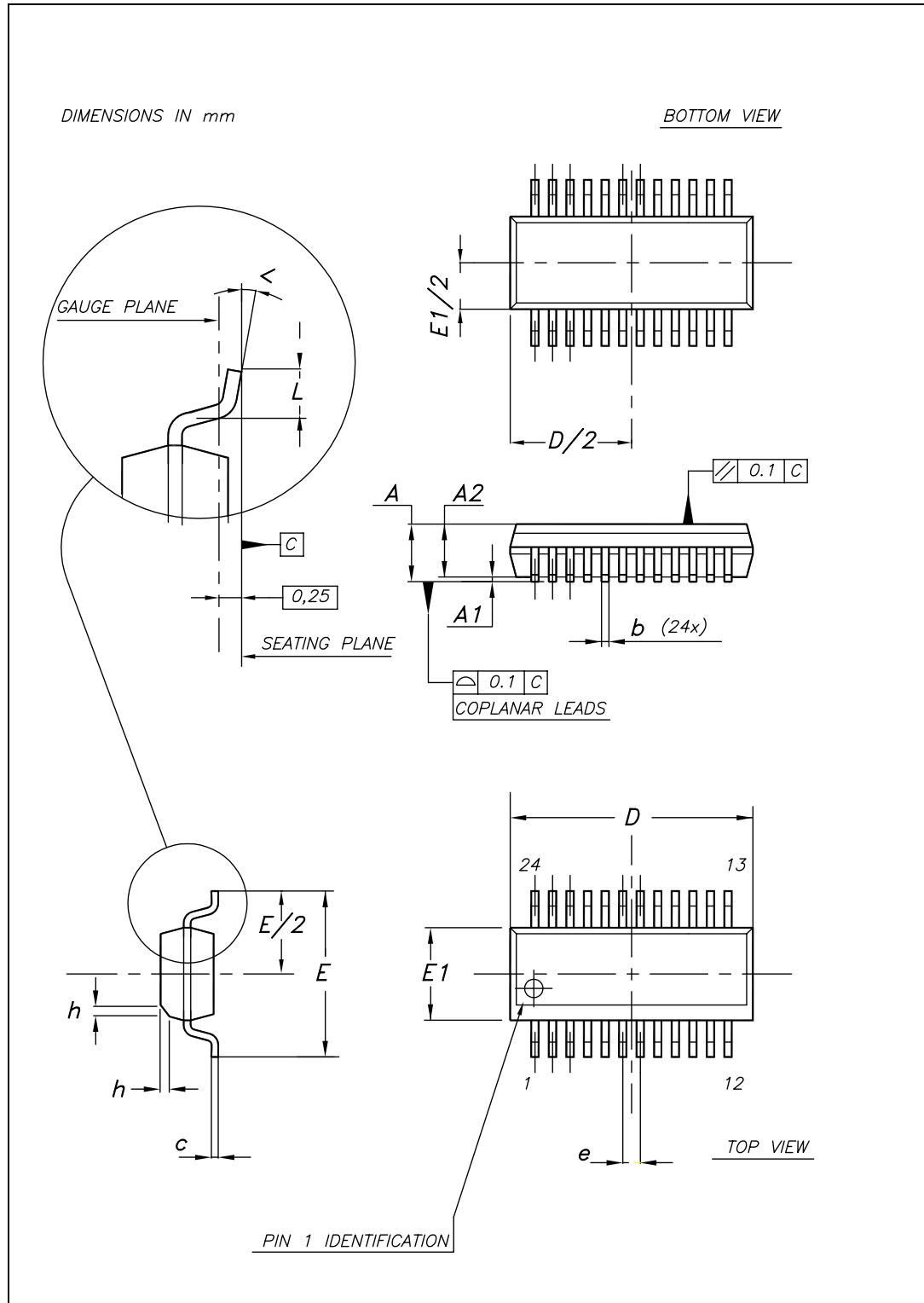

Table 13. QSOP-24 tape and reel

Dim.	mm.			inch		
	Min.	Typ.	Max.	Min.	Typ.	Max.
R1	12.8	13	13.5	5.039	5.118	5.315
R2		330			129.921	
R3		100			39.37	
eint		16.4			6.457	
e1	1.5	2	2.5	0.591	0.787	0.984

Table 14. QSOP-24 tape and reel dimensions

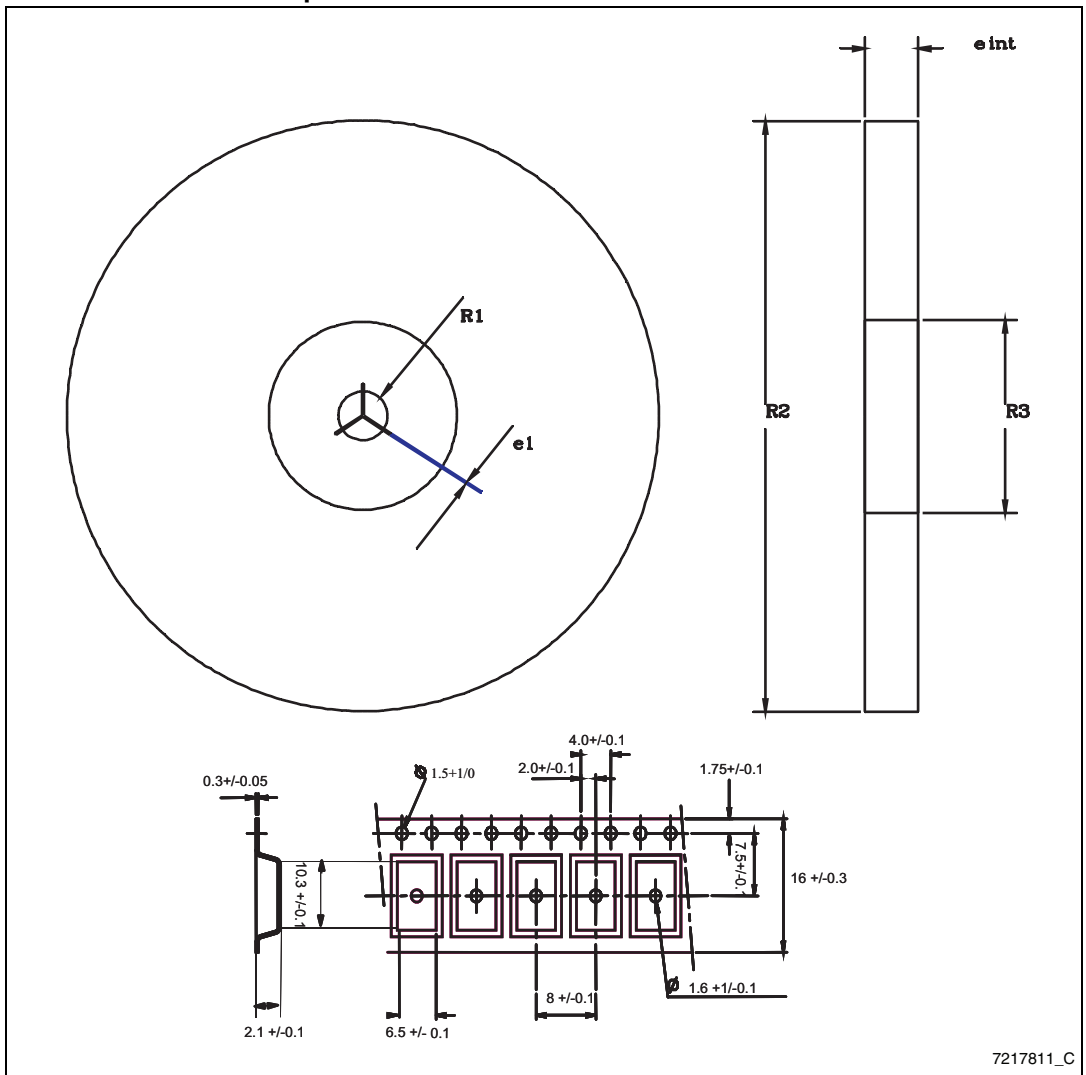

Table 15. TSSOP24 mechanical data

Dim.	mm.			inch		
	Min.	Typ.	Max.	Min.	Typ.	Max.
A			1.1			0.043
A1	0.05		0.15	0.002		0.006
A2		0.9			0.035	
b	0.19		0.30	0.0075		0.0118
c	0.09		0.20	0.0035		0.0079
D	7.7		7.9	0.303		0.311
E	4.3		4.5	0.169		0.177
e		0.65 BSC			0.0256 BSC	
H	6.25		6.5	0.246		0.256
K	0°		8°	0°		8°
L	0.50		0.70	0.020		0.028

Figure 22. TSSOP24 package dimensions

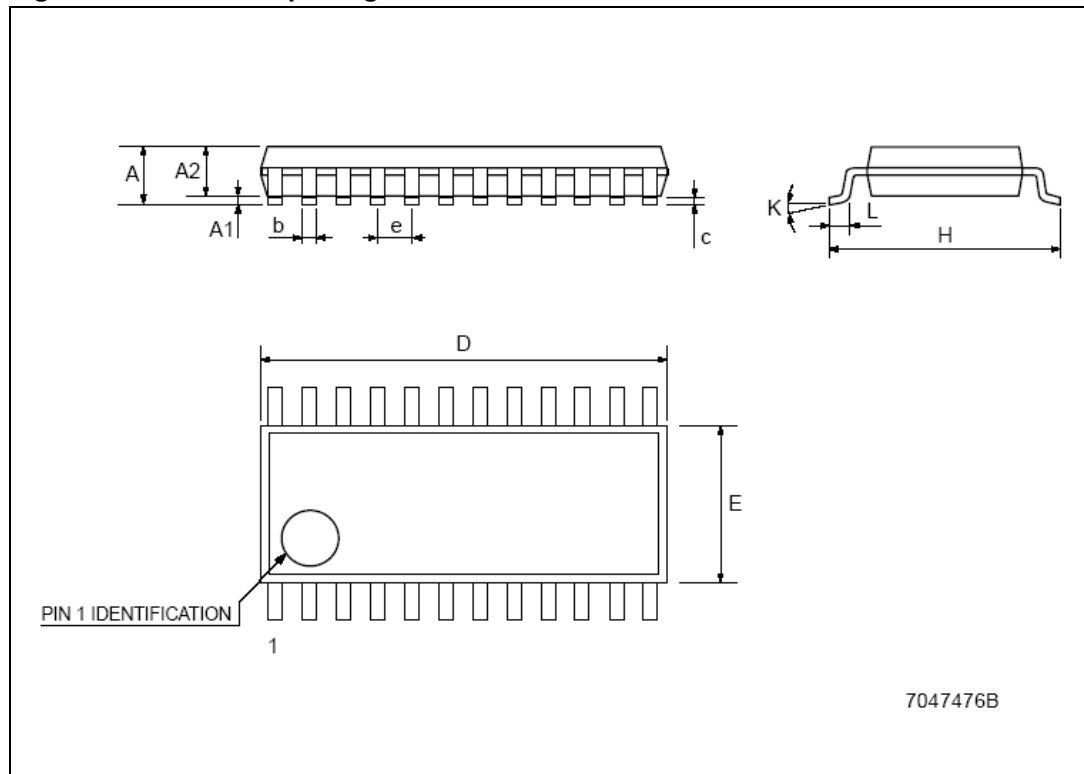

Table 16. Tape and reel TSSOP24

Dim.	mm.			inch		
	Min.	Typ.	Max.	Min.	Typ.	Max.
A		-	330		-	12.992
C	12.8	-	13.2	0.504	-	0.519
D	20.2	-		0.795	-	
N	60	-		2.362	-	
T		-	22.4		-	0.882
Ao	6.8	-	7	0.268	-	0.276
Bo	8.2	-	8.4	0.323	-	0.331
Ko	1.7	-	1.9	0.067	-	0.075
Po	3.9	-	4.1	0.153	-	0.161
P	11.9	-	12.1	0.468	-	0.476

Figure 23. TSSOP24 reel dimensions

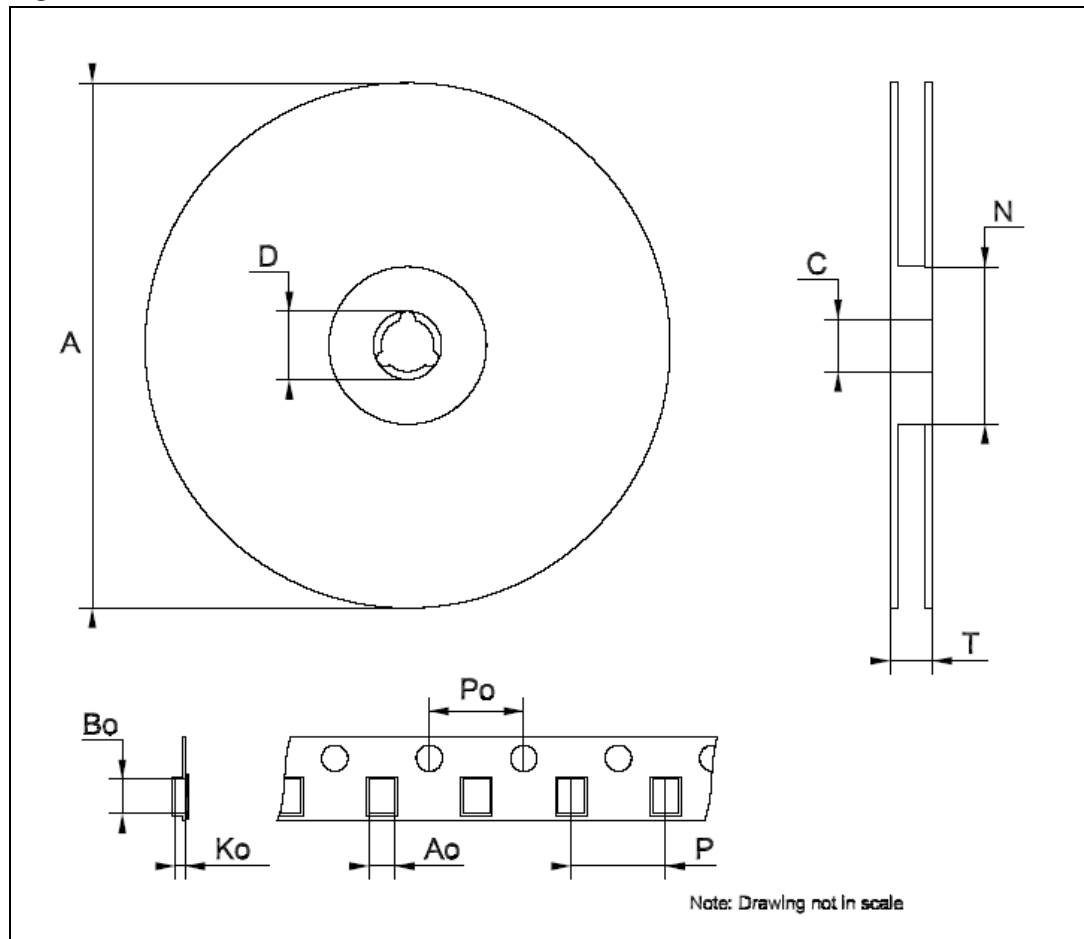
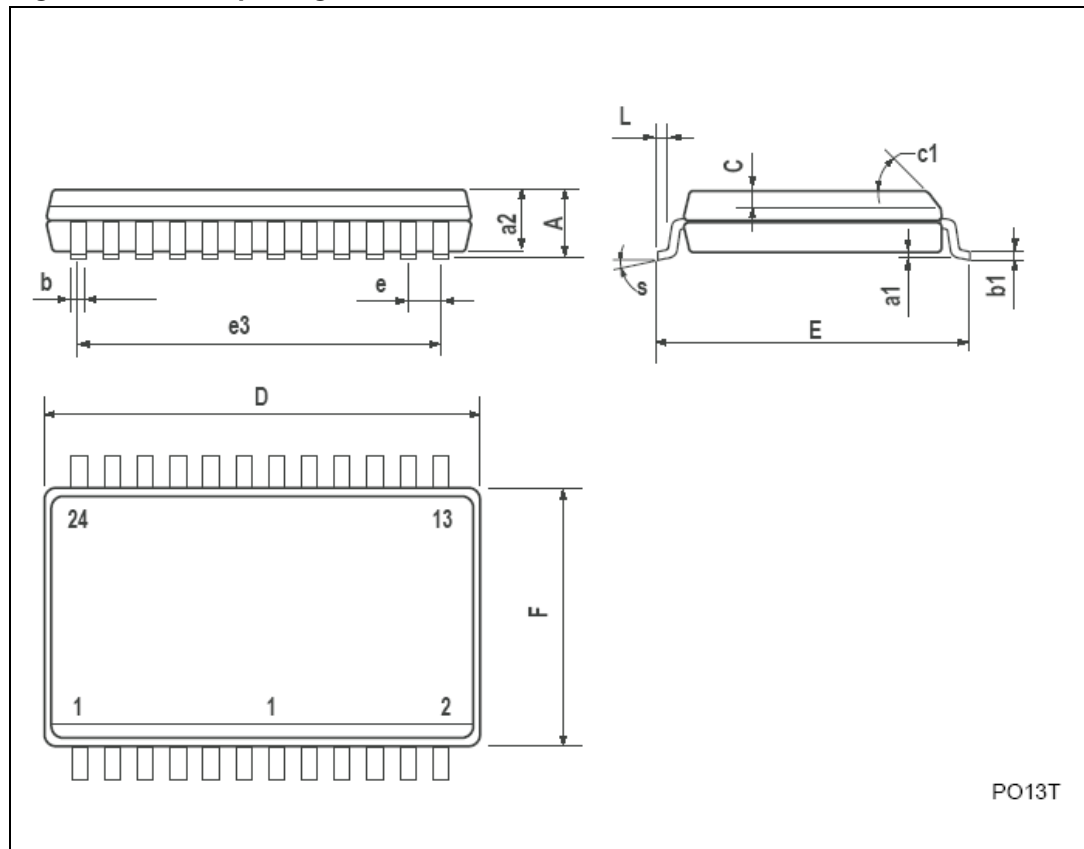

Table 17. SO-24 mechanical data

Dim.	mm.			inch		
	Min.	Typ.	Max.	Min.	Typ.	Max.
A			2.65			0.104
a1	0.1		0.2	0.004		0.008
a2			2.45			0.096
b	0.35		0.49	0.014		0.019
b1	0.23		0.32	0.009		0.012
C		0.5			0.020	
c1	45°(typ.)					
D	15.20		15.60	0.598		0.614
E	10.00		10.65	0.393		0.419
e		1.27			0.050	
e3		13.97			0.550	
F	7.40		7.60	0.291		0.300
L	0.50		1.27	0.020		0.050
S	°(max.) 8					

Figure 24. SO-24 package dimensions



PO13T

Table 18. Tape and reel SO-24

Dim.	mm.			inch		
	Min.	Typ.	Max.	Min.	Typ.	Max.
A		-	330		-	12.992
C	12.8	-	13.2	0.504	-	0.519
D	20.2	-		0.795	-	
N	60	-		2.362	-	
T		-	30.4		-	1.197
Ao	10.8	-	11.0	0.425	-	0.433
Bo	15.7	-	15.9	0.618	-	0.626
Ko	2.9	-	3.1	0.114	-	0.122
Po	3.9	-	4.1	0.153	-	0.161
P	11.9	-	12.1	0.468	-	0.476

Figure 25. Reel dimensions SO-24

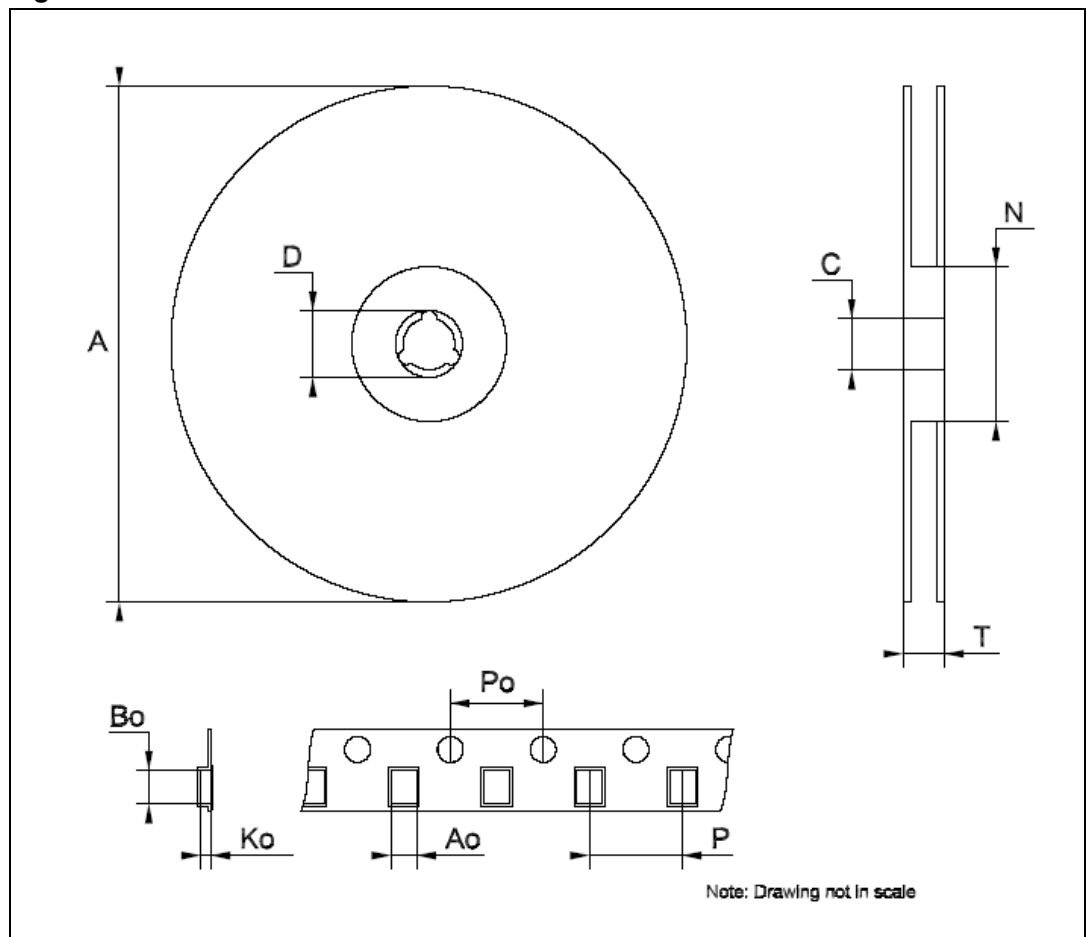
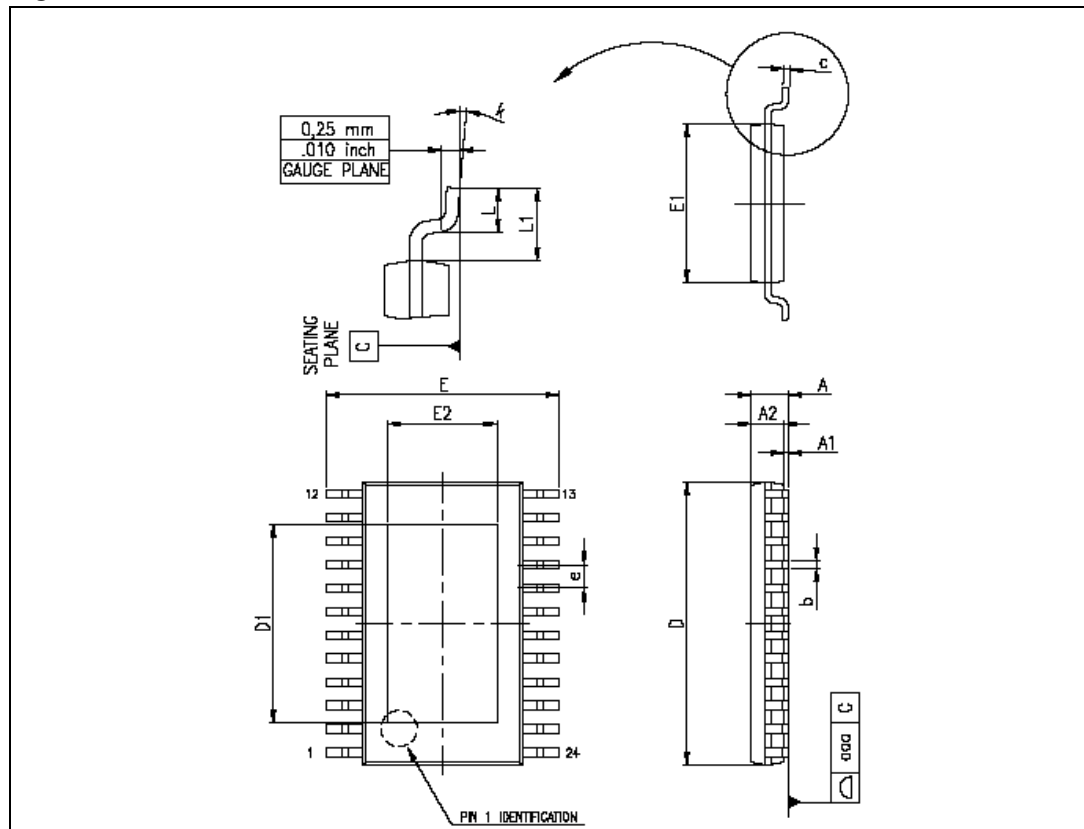

Table 19. TSSOP24 exposed-pad

Dim.	mm			inch		
	Min.	Typ.	Max.	Min.	Typ.	Max.
A			1.2			0.047
A1			0.15		0.004	0.006
A2	0.8	1	1.05	0.031	0.039	0.041
b	0.19		0.30	0.007		0.012
c	0.09		0.20	0.004		0.0089
D	7.7	7.8	7.9	0.303	0.307	0.311
D1	4.7	5.0	5.3	0.185	0.197	0.209
E	6.2	6.4	6.6	0.244	0.252	0.260
E1	4.3	4.4	4.5	0.169	0.173	0.177
E2	2.9	3.2	3.5	0.114	0.126	0.138
e		0.65			0.0256	
K	0°		8°	0°		8°
L	0.45	0.60	0.75	0.018	0.024	0.030

Figure 26. TSSOP24 dimensions





## 9 Revision history

**Table 20. Document revision history**

Date	Revision	Changes
28-Jul-2006	1	First release
21-Dec-2006	2	Final datasheet
17-May-2007	3	Updated <a href="#">Table 7 on page 5</a>
10-Jul-2007	4	Updated <a href="#">Table 9: Truth table on page 9</a>
12-Mar-2008	5	Updated <a href="#">Table 15: TSSOP24 exposed-pad on page 23</a> , added QSOP-24 <a href="#">Table 12</a> and <a href="#">Figure 21 on page 18</a>
07-May-2008	6	Updated <a href="#">Section 5 on page 9</a>
03-Dec-2008	7	Updated cover page, <a href="#">Table 6 on page 4</a> , <a href="#">Table 7 on page 5</a> , <a href="#">Table 8 on page 6</a> , <a href="#">Figure 12 on page 12</a> , <a href="#">Table 10 on page 12</a> , <a href="#">Figure 13, 14</a> , and <a href="#">Figure 15 on page 14</a>
12-May-2009	8	Updated cover page, <a href="#">Table 6 on page 4</a> , <a href="#">Table 7 on page 5</a> , <a href="#">Table 8 on page 6</a>

**Please Read Carefully:**

Information in this document is provided solely in connection with ST products. STMicroelectronics NV and its subsidiaries ("ST") reserve the right to make changes, corrections, modifications or improvements, to this document, and the products and services described herein at any time, without notice.

All ST products are sold pursuant to ST's terms and conditions of sale.

Purchasers are solely responsible for the choice, selection and use of the ST products and services described herein, and ST assumes no liability whatsoever relating to the choice, selection or use of the ST products and services described herein.

No license, express or implied, by estoppel or otherwise, to any intellectual property rights is granted under this document. If any part of this document refers to any third party products or services it shall not be deemed a license grant by ST for the use of such third party products or services, or any intellectual property contained therein or considered as a warranty covering the use in any manner whatsoever of such third party products or services or any intellectual property contained therein.

**UNLESS OTHERWISE SET FORTH IN ST'S TERMS AND CONDITIONS OF SALE ST DISCLAIMS ANY EXPRESS OR IMPLIED WARRANTY WITH RESPECT TO THE USE AND/OR SALE OF ST PRODUCTS INCLUDING WITHOUT LIMITATION IMPLIED WARRANTIES OF MERCHANTABILITY, FITNESS FOR A PARTICULAR PURPOSE (AND THEIR EQUIVALENTS UNDER THE LAWS OF ANY JURISDICTION), OR INFRINGEMENT OF ANY PATENT, COPYRIGHT OR OTHER INTELLECTUAL PROPERTY RIGHT.**

**UNLESS EXPRESSLY APPROVED IN WRITING BY AN AUTHORIZED ST REPRESENTATIVE, ST PRODUCTS ARE NOT RECOMMENDED, AUTHORIZED OR WARRANTED FOR USE IN MILITARY, AIR CRAFT, SPACE, LIFE SAVING, OR LIFE SUSTAINING APPLICATIONS, NOR IN PRODUCTS OR SYSTEMS WHERE FAILURE OR MALFUNCTION MAY RESULT IN PERSONAL INJURY, DEATH, OR SEVERE PROPERTY OR ENVIRONMENTAL DAMAGE. ST PRODUCTS WHICH ARE NOT SPECIFIED AS "AUTOMOTIVE GRADE" MAY ONLY BE USED IN AUTOMOTIVE APPLICATIONS AT USER'S OWN RISK.**

Resale of ST products with provisions different from the statements and/or technical features set forth in this document shall immediately void any warranty granted by ST for the ST product or service described herein and shall not create or extend in any manner whatsoever, any liability of ST.

ST and the ST logo are trademarks or registered trademarks of ST in various countries.

Information in this document supersedes and replaces all information previously supplied.

The ST logo is a registered trademark of STMicroelectronics. All other names are the property of their respective owners.

© 2009 STMicroelectronics - All rights reserved

STMicroelectronics group of companies

Australia - Belgium - Brazil - Canada - China - Czech Republic - Finland - France - Germany - Hong Kong - India - Israel - Italy - Japan - Malaysia - Malta - Morocco - Philippines - Singapore - Spain - Sweden - Switzerland - United Kingdom - United States of America

[www.st.com](http://www.st.com)